

Form No.  
907389

# 1 639/1 649

## PowerBox Self Propelled Paver

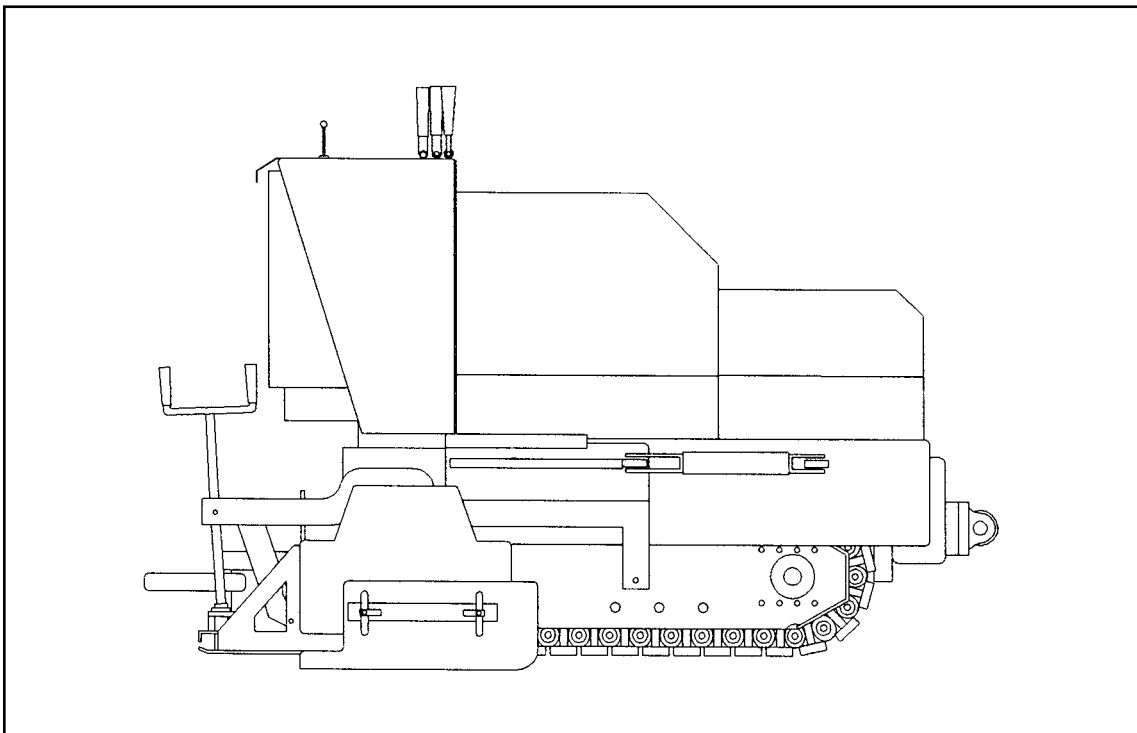

**GEHL**<sup>®</sup>

# OPERATOR'S MANUAL

---

---

**GEHL**  
**NEW CONSTRUCTION EQUIPMENT**  
**POWER BOX PAVER**  
**WARRANTY**

**GEHL CONSTRUCTION DIVISION** of the **GEHL COMPANY**, hereinafter referred to as **GEHL**, warrants new **GEHL Power Box Pavers**, to the Original Retail Purchaser to be free from defects in material and workmanship for a period of twelve (12) months from the Warranty Start Date.

**GEHL CONSTRUCTION WARRANTY INCLUDES:**

Genuine Gehl parts and labor costs required to repair or replace equipment at the selling dealer's business location.

---

**GEHL MAKES NO REPRESENTATIONS OR WARRANTIES OF ANY KIND, EXPRESS OR IMPLIED (INCLUDING THE IMPLIED WARRANTIES OF MERCHANTABILITY AND FITNESS FOR PARTICULAR PURPOSE), EXCEPT AS EXPRESSLY STATED IN THIS WARRANTY STATEMENT.**

---

**GEHL WARRANTY DOES NOT INCLUDE:**

1. Transportation to selling dealer's business location or, at the option of the Original Retail Purchaser, the cost of a service call.
2. Used equipment.
3. Components covered by their own non-Gehl warranties, such as tires, trade accessories and engines.
4. Normal maintenance service and expendable, high wear items.
5. Repairs or adjustments caused by: improper use; failure to follow recommended maintenance procedures; use of unauthorized attachments; accident or other casualty.
6. Liability for incidental or consequential damages of any type, including, but not limited to lost profits expenses of acquiring replacement equipment.

No agent, employee or representative of **GEHL** has any authority to bind **GEHL** to any warranty except as specifically set forth herein. Any of these limitations excluded by local law shall be deemed deleted from this warranty; all other terms will continue to apply.

---

---

# Table of Contents

Chapter	Description	Page
	Warranty . . . . .	Inside Front Cover
<b>1</b>	Introduction . . . . .	<b>1</b>
<b>2</b>	Specifications . . . . .	<b>4</b>
<b>3</b>	Check Lists . . . . .	<b>7</b>
<b>4</b>	<b>SAFETY</b> . . . . .	<b>10</b>
<b>5</b>	Controls, Attachments & Accessories . . . . .	<b>16</b>
<b>6</b>	Operation & Adjustments . . . . .	<b>24</b>
<b>7</b>	Lubrication . . . . .	<b>33</b>
<b>8</b>	Trouble Shooting . . . . .	<b>36</b>
<b>9</b>	Service & Storage . . . . .	<b>44</b>
<b>10</b>	Decal Locations . . . . .	<b>58</b>
<b>11</b>	Maintenance Log . . . . .	<b>62</b>
	Index . . . . .	<b>66</b>
	Standard Hardware Torque Data . . . . .	<b>68</b>
	International Symbols . . . . .	Inside Back Cover

## IDENTIFICATION INFORMATION

Write your Gehl PowerBox Model (1639, or 1649) and Serial Numbers in the space provided below. Refer to these numbers when inquiring about parts or service from your Gehl dealer.

MODEL NO. _____
SERIAL NO. _____
<b>GEHL</b> <sup>®</sup> WEST BEND, WI 53095 U.S.A.

The Model and Serial Numbers for this machine are on a Decal located on the Backwall.

# Chapter 1

## INTRODUCTION

The information in this Operator's Manual was written to give the owner/operator assistance in preparing, adjusting, maintaining and servicing of the Paver. More importantly, this manual provides an operating plan for safe and proper use of the machine. Major points of safe operation are detailed in the **SAFETY** chapter of this manual. A chart of standard hardware torques is located in the back of this manual.

**The GEHL Company asks that you read and understand the contents of this manual COMPLETELY and become familiar with your new machine, BEFORE attempting to operate it.**

Throughout this manual, information is provided which is set in *italic* type and introduced by the word **NOTE**. Be sure to read carefully and comply with the message or directive given. Following this information will improve your operating or maintenance efficiency, help you to avoid breakdowns or damage and extend your machine's life.

A plastic container is provided on the unit for storing the Operator's Manual. After using the Manual, please return it to the container and keep it with the unit at all times! If this machine is resold, **GEHL** Company recommends that this Manual be given to the new owner.

"Right" and "left" are determined from a position standing on the Screed Platform and facing forward.

Our wide Dealership network stands by to provide you with any assistance you may require, including genuine **GEHL** service parts. All parts should be obtained from or ordered through your **GEHL** Dealer. Give complete information about the part and include the model and serial numbers of your machine. Record the serial number in the space provided on the previous page, as a handy record for quick reference.

**GEHL** Company reserves the right to make changes or improvements in the design or construction of any part without incurring the obligation to install such changes on any unit previously delivered.

**The GEHL Company, in cooperation with the American Society of Agricultural Engineers and the Society of Automotive Engineers, has adopted this**

### SAFETY ALERT SYMBOL



**to pin point characteristics which, if NOT properly followed, can create a safety hazard. When you see this symbol in this manual or on the machine itself, you are reminded to BE ALERT! Your personal safety is involved!**

# Paver Identification

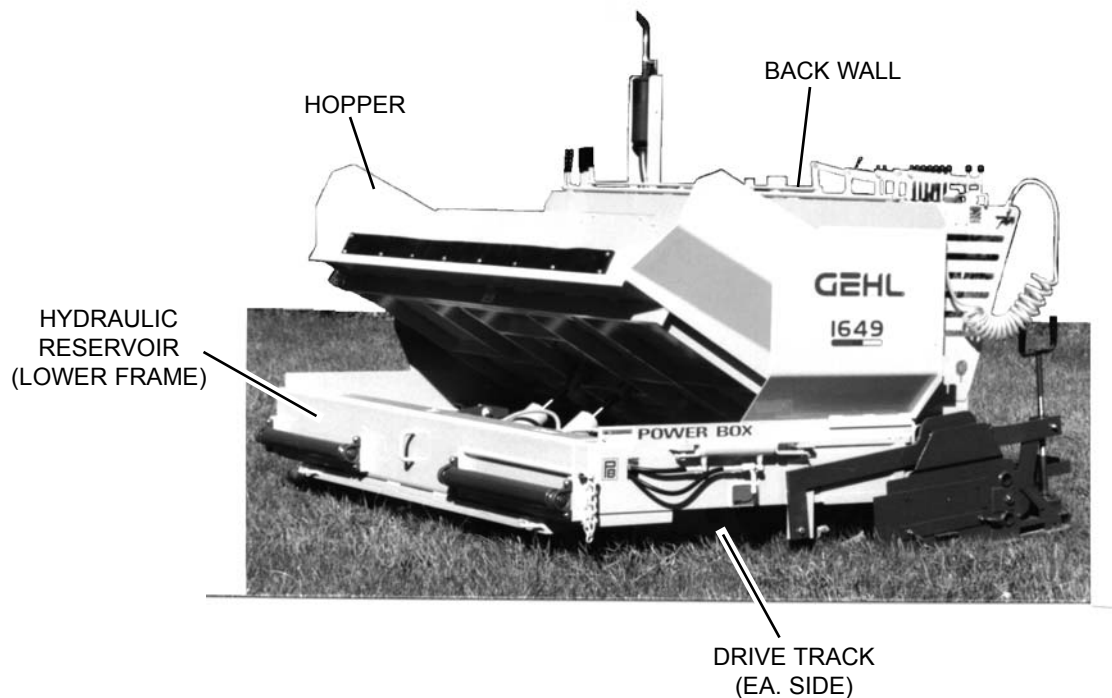
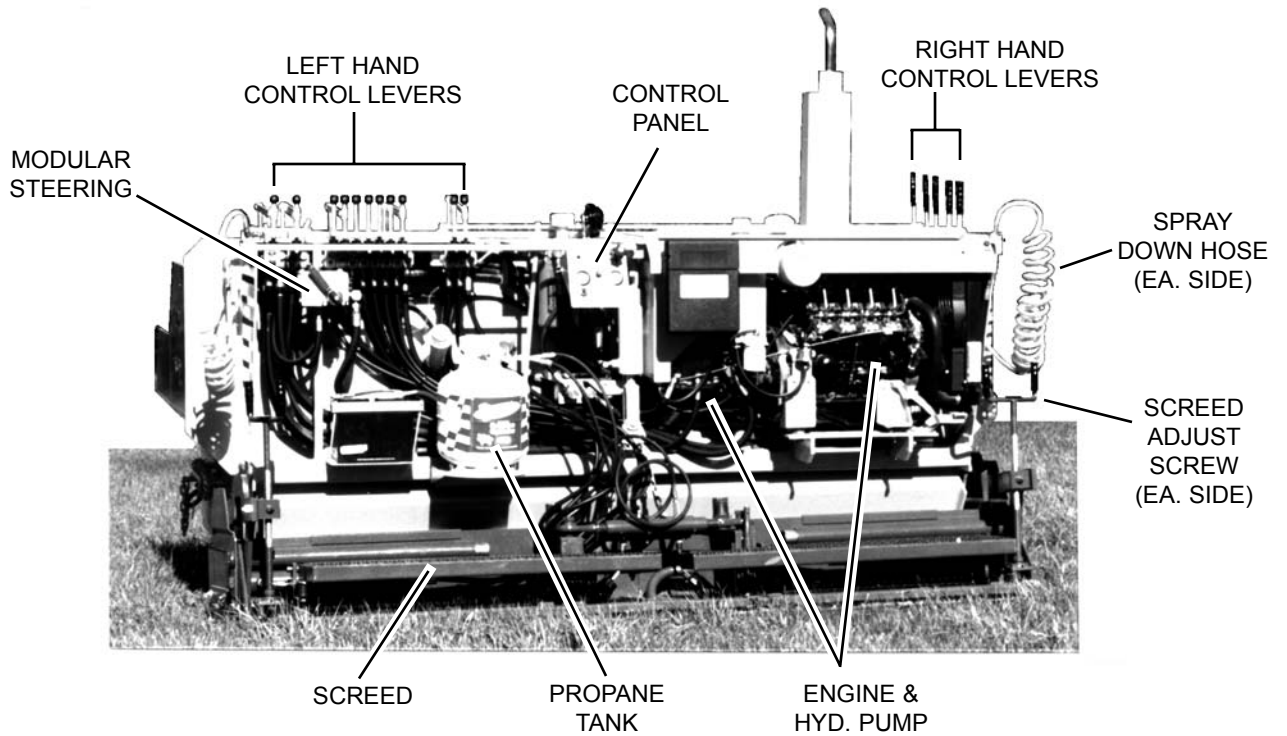

# Chapter 2

## SPECIFICATIONS

<b>Gehl PowerBox Paver Models:</b>	<b>1639</b>	<b>1649</b>
<b>General Dimensions:</b>		
Length.....	8 ft. (2438 mm)	8 ft. (2438 mm)
Minimum Width ( <i>Transport</i> ).....	9 ft. 10 in. (2997 mm)	9 ft. 10 in. (2997 mm)
Maximum Width ( <i>Operating</i> ).....	9 ft. 10 in. (2997 mm)	9 ft. 10 in. (2997 mm)
Overall Height.....	5 ft. 5 in. (1651 mm)	5 ft. 5 in. (1651 mm)
Weight.....	8,395 lb. (3803 kg)	8,460 lb. (3803 kg)
Truck Clearance ( <i>Height from ground to asphalt hopper floor</i> ).....	21 in. (533 mm)	21 in. (533 mm)
<b>Screed:</b>		
Maximum Variable Crown/Invert.....	2 in. (51 mm)	2 in. (51 mm)
Width.....	12 in. (305 mm)	12 in. (305 mm)
Hydraulic Vibrator.....	Std. (83 Hz.) (5000 cy/min)	Std. 83 Hz.) (5000 cy/min)
Heat Medium (Exhaust).....	Standard	Standard
Heat Medium (Propane).....	Optional	Optional
Variable Hydraulic Strike Off Max. Extension Length.....	18 in. (457 mm)	18 in. (457 mm)
Dual Span Operator Platform (Isolated).....	Standard	Standard
<b>Service Capacities:</b>		
Engine Cooling System (Isuzu - 4LC1).....	N/A	6.8 Qt. (6.4 Liter)
Engine Oil w/Filter (Wisconsin - VH4D).....	4 Qt. (3.8 Liter)	N/A
Engine Oil w/Filter (Isuzu 4LC1).....	N/A	6.9 qt. (6.5 Liter)

# SPECIFICATIONS (Continued)

<b>Gehl PowerBox Paver Models:</b>	<b>1639</b>	<b>1649</b>
<b>Service Capacities (Continued):</b>		
Hydraulic Reservoir . . . . .	20 Gal. (75.7 Liter)	20 Gal. 75.7 Liter
Fuel Reservoir . . . . .	12 Gal. 45.4 Liter)	12 Gal. (45.4 Liter)
Wash Down Tank w/Electric Pump . . . . .	4.5 Gallons) (17 Liter)	4.5 Gallons) (17 Liter)
<b>Engine:</b>		
Wisconsin - VH4D, 30 HP (22.4 Kw) Gas, Air-Cooled, 12 Volt Electric Start, 30 Amp Alternator, 575 CCA Battery . . . . .	Standard	N/A
Isuzu - 4LC1, 41 HP (30.6 Kw) Diesel, Water-Cooled, 12 Volt Electric Start, 35 Amp Alternator, 575 CCA Battery . . . . .	N/A	Standard
<b>Drive System:</b>		
Hydrostatic Steel Track Type, Single-Speed, Positive/Self-Adjusting Counter-Rotating, Fine Tune Steering Valve . . . . .	Std.	Std.
Maximum Ground Speed . . . . .	130 FPM (39.7 mpm)	130 FPM (39.7 mpm)
<b>Hydraulic System:</b>		
Variable Hydrostatic Drive Pump - Maximum Flow . . . . .	27 GPM (102 Ltrs/M)	27 GPM (102 Ltrs/M)
Variable Hydrostatic Drive Pump - Maximum Relief Pressure . . . . .	3500 PSI (24.5 Bar)	3500 PSI (24.5 Bar)
Hydraulic Auger Drive Pump - Maximum Flow . . . . .	12 GPM (45.4 Ltrs/M)	12 GPM (45.4 Ltrs/M)
Hydraulic Auger Drive Pump - Maximum Relief Pressure . . . . .	2000 PSI (14 Bar)	2000 PSI (14 Bar)
Hydraulic Cylinder Pump - Maximum Flow . . . . .	12 GPM (45.4 Ltrs/M)	12 GPM (45.4 Ltrs/M)
Hydraulic Cylinder Pump - Maximum Relief Pressure . . . . .	1800 PSI (126 Bar)	1800 PSI (126 Bar)
Return Filter . . . . .	5 Micron	5 Micron
Suction Strainer . . . . .	100 Micron	100 Micron
Aux. Oil Cooler Capacity . . . . .	12 GPM (45.4 Ltrs/M)	12 GPM (45.4 Ltrs/M)

# SPECIFICATIONS (Continued)

<b>Gehl PowerBox Paver Models:</b>	<b>1639</b>	<b>1649</b>
<b>Paving Performance:</b>		
Minimum Variable Paving Width . . . . .	4.5 ft. (1372 mm)	4.5 ft. (1372 mm)
Maximum Variable Paving Width . . . . .	12 ft. (3658 mm)	12 ft. (3658 mm)
Minimum Variable Paving Depth . . . . .	0-1/2 in. (0-13 mm)	0-1/2 in. (0-13 mm)
Maximum Variable Paving Depth . . . . .	6 in. (152.4 mm)	6 in. (152.4 mm)
Gravity Feed Hopper Capacity . . . . .	6 Ton (5436 kg)	6 Ton (5436 kg)
Hydraulic Feed Augers . . . . .	2	2
Hydraulic Material Flow Gates . . . . .	2	2
Operating Speed . . . . .	0-130 FPM (0-40 mpm)	0-130 FPM (0-40 mpm)
Left and Right Side Operator Controls . . . . .	Standard	Standard



# Chapter 3

## CHECKLISTS

### PRE-DELIVERY

The following Checklist is an important reminder of valuable information and inspections which **MUST** be made before delivering the Paver to the Customer. Check off each item after prescribed action is taken.

#### Check that:

- NO parts of Paver have been damaged in shipment. Check for such things as dents and loose or missing parts; correct or replace components as required.
- Battery is securely mounted and NOT cracked. Cable connections are tight. Electrolyte at proper level.
- Cylinders, hoses and fittings are NOT damaged, leaking or loosely secured.
- Oil, fuel and air filters are NOT damaged leaking or loosely secured.
- All grease fittings have been properly lubricated and NO fittings are missing; see Lubrication chapter of this manual.
- Hydraulic system reservoir, engine crankcase, and engine coolant are filled to the proper operating levels.
- All adjustments have been made to comply with the settings given in this manual and in the separate Engine manual.
- All Guards, Shields and Decals are in place and securely attached.
- Model and Serial Number for this unit is recorded in space provided on this page and page 1.

**Start the Paver and test-run the unit while checking that proper operation is exhibited by all controls.**

#### Check that:

- All indicator lamps, meters, etc. function properly.
- Proper operation of all Hopper and Screed Controls.
- Dynamic braking in effect with Drive Motors in neutral.
- No hydraulic system leaks when under pressure.
- Listen for abnormal noises or vibrations; if detected, determine their cause and repair as necessary.

I acknowledge that pre-delivery procedures were performed on this unit as outlined above.

---

Dealership's Name

---

Dealer Representative's Name

---

Date Checklist filled-out

---

Paver Model#	Paver Serial #	Engine Serial #
--------------	----------------	-----------------

### DELIVERY

#### Check that:

The following Checklist is an important reminder of valuable information that **MUST** be passed on to the Customer at the time the unit is delivered. Check off each item as you explain it to the Customer.

- Review with the Customer the contents of this manual; especially:
- The INDEX at the back, for quickly locating topics;
- The SAFETY, CONTROLS/ATTACHMENTS & ACCESSORIES, and OPERATION/ADJUSTMENTS Chapters for information regarding safe use of the machine.
- The LUBRICATION, SERVICE and TROUBLESHOOTING Chapters, for information regarding proper maintenance of the machine. Explain that regular lubrication and maintenance are required for continued safe operation and long life.
- Give this Operator's Manual to the Customer and instruct the Customer to be sure to read and completely understand its contents BEFORE operating the unit.
- Explain that the Customer **MUST** consult the Engine Manual (provided) for related specifications, operating adjustments and maintenance instructions.
- Completely fill out the Owner's Registration, including Customer's signature and, return it to the company.

---

Customer's Signature

---

Date Delivered

**INTENTIONALLY BLANK**

**(To be removed as Dealer's file copy)**

# Chapter 3

## CHECKLISTS

### PRE-DELIVERY

The following Checklist is an important reminder of valuable information and inspections which **MUST** be made before delivering the Paver to the Customer. Check off each item after prescribed action is taken.

#### Check that:

- NO parts of Paver have been damaged in shipment. Check for such things as dents and loose or missing parts; correct or replace components as required.
- Battery is securely mounted and NOT cracked. Cable connections are tight. Electrolyte at proper level.
- Cylinders, hoses and fittings are NOT damaged, leaking or loosely secured.
- Oil, fuel and air filters are NOT damaged leaking or loosely secured.
- All grease fittings have been properly lubricated and NO fittings are missing; see Lubrication chapter of this manual.
- Hydraulic system reservoir, engine crankcase, and engine coolant are filled to the proper operating levels.
- All adjustments have been made to comply with the settings given in this manual and in the separate Engine manual.
- All Guards, Shields and Decals are in place and securely attached.
- Model and Serial Number for this unit is recorded in space provided on this page and page 1.

**Start the Paver and test-run the unit while checking that proper operation is exhibited by all controls.**

#### Check that:

- All indicator lamps, meters, etc. function properly.
- Proper operation of all Hopper and Screed Controls.
- Dynamic braking in effect with Drive Motors in neutral.
- No hydraulic system leaks when under pressure.
- Listen for abnormal noises or vibrations; if detected, determine their cause and repair as necessary.

I acknowledge that pre-delivery procedures were performed on this unit as outlined above.

---

Dealership's Name

---

Dealer Representative's Name

---

Date Checklist filled-out

---

Paver Model#	Paver Serial #	Engine Serial #
--------------	----------------	-----------------

### DELIVERY

#### Check that:

The following Checklist is an important reminder of valuable information that **MUST** be passed on to the Customer at the time the unit is delivered. Check off each item as you explain it to the Customer.

- Review with the Customer the contents of this manual; especially:
- The INDEX at the back, for quickly locating topics;
- The SAFETY, CONTROLS/ATTACHMENTS & ACCESSORIES, and OPERATION/ADJUSTMENTS Chapters for information regarding safe use of the machine.
- The LUBRICATION, SERVICE and TROUBLESHOOTING Chapters, for information regarding proper maintenance of the machine. Explain that regular lubrication and maintenance are required for continued safe operation and long life.
- Give this Operator's Manual to the Customer and instruct the Customer to be sure to read and completely understand its contents BEFORE operating the unit.
- Explain that the Customer **MUST** consult the Engine Manual (provided) for related specifications, operating adjustments and maintenance instructions.
- Completely fill out the Owner's Registration, including Customer's signature and, return it to the company.

---

Customer's Signature

---

Date Delivered

*(Pages 7 & 8 have been removed at Perforation)*



# Chapter 4

# SAFETY



The above Safety Alert Symbol means **ATTENTION! ALWAYS BE ALERT! YOUR SAFETY IS INVOLVED!** It stresses an attitude of “Heads Up for Safety” and can be found throughout this Operator’s Manual and the machine itself.

**BEFORE YOU ATTEMPT TO OPERATE THIS EQUIPMENT READ AND STUDY THE FOLLOWING SAFETY INFORMATION. IN ADDITION, MAKE SURE THAT EVERY INDIVIDUAL WHO OPERATES OR WORKS WITH THIS EQUIPMENT, WHETHER FAMILY MEMBER OR EMPLOYEE, IS FAMILIAR WITH THESE SAFETY PRECAUTIONS.**

The Gehl Company **ALWAYS** takes the operator’s safety into consideration when designing its machinery and guards exposed moving parts for his/her protection. However, some areas can **NOT** be guarded or shielded in order to assure proper operation. In addition, this Operator’s Manual and Decals, on the machine, warn of further danger and should be read and observed closely.

---



## DANGER

“**DANGER**” indicates an imminently hazardous situation which, if not avoided, will result in death or serious injury.

---



## WARNING

“**WARNING**” indicates a potentially hazardous situation which, if not avoided, could result in death or serious injury.

---



## CAUTION

“**CAUTION**” indicates a potentially hazardous situation which, if not avoided, may result in minor or moderate injury. Also alerts to unsafe practices.

**REMEMBER!** It is the owner’s responsibility for communicating information on the safe use and proper maintenance of this machine! This includes providing understandable interpretation of these instructions for operators who are not fluent in reading English.

---

### MANDATORY SAFETY SHUTDOWN PROCEDURE

**BEFORE cleaning, adjusting, lubricating or servicing the unit:**

1. Bring machine to full parking stop on level surface (NEVER park on a slope or hill side).
2. Lower the Hopper and Screed Assembly to the “full down” position.
3. Place controls in Neutral.
4. Move the Throttle to low idle.
5. Shut off the Engine and remove the Key.

**ONLY when you have taken these precautions can you be sure it is safe to proceed. Failure to follow the above procedure, could lead to death or serious bodily injury.**

---

### ADDITIONAL SAFETY REMINDERS

- USER/OPERATOR SAFETY PRACTICES, as established by Industry Standards, are included in this Operator’s Manual and intended to promote **SAFE OPERATION** of the Paver. These guidelines do **NOT** preclude the use of good judgment, care and common sense as may be indicated by the particular jobsite work conditions.
- It is essential that operators be physically and mentally free of mind altering drugs and chemicals and thoroughly trained in the safe operation of the Paver. Such training should be presented completely to all new operators and not condensed for those claiming previous experience. Information on operator training is available from several sources including the manufacturer.



# SAFETY

## (Continued)



- Some illustrations, used in this manual, may show Doors, Guards and Shields open or removed for illustration purposes ONLY. Be SURE that all Doors, Guards and Shields are in their proper operating positions BEFORE starting the Engine to operate the Paver.
- ALWAYS wear appropriate personal safety gear called by the job or working conditions. Do NOT wear loose or baggy clothing while operating or servicing the machine.
- ALWAYS maintain safe clearance from electrical powerlines and avoid contact with any electrically charged conductor. Contact can result in electrocution. Contact proper local authorities for utility line location BEFORE starting a job.
- ALWAYS check the job site for obstructions and bystanders!
- NEVER use your hands to search for hydraulic fluid leaks. Use a piece of paper or cardboard. Escaping fluid under pressure can be invisible and can penetrate the skin causing serious injury. If any fluid is injected into your skin, see a doctor at once. Injected fluid MUST be surgically removed by a doctor familiar with this type of injury or gangrene may result!
- Do NOT attempt to move HOT asphalt mix with your hands or feet. Contact can cause serious skin burns!
- Do NOT allow minors or any unqualified personnel to operate or be near the Paver unless properly supervised!
- Do NOT operate the Paver in an enclosed area without adequate ventilation! Internal combustion engines deplete the oxygen supply within enclosed spaces and may create a serious hazard unless the oxygen is replaced!
- Do NOT leave the Paver unattended with the Engine running. ALWAYS lower the Hopper to “full down” position, shut off the Engine and place all controls in neutral BEFORE leaving the machine!
- ALWAYS position the Safety Props when leaving the Hopper raised for inspection, cleaning or service!
- Do NOT attempt to refill the Fuel Reservoir when the Engine is hot. Allow Engine to cool down BEFORE refilling to prevent hot Engine from igniting the fuel if it should spill or splash!
- Do NOT smoke while filling the Fuel Reservoir, while working on the fuel or hydraulic systems, or while working around the Battery!
- Do NOT attempt to loosen or disconnect ANY Hydraulic Lines, Hoses or Fittings without first relieving hydraulic circuit pressure. Also, be careful NOT to touch any hydraulic components that have been in recent operation because they can be extremely HOT and can burn you!
- ALWAYS disconnect the Battery connection to prevent unintentional starting while working on this machine!
- Do NOT attempt to remove the Radiator Cap after the Engine has reached operating temperature or if it is overheated. At operating temperatures, the Engine Coolant will be extremely HOT and under pressure. ALWAYS wait for the Engine to cool down before attempting to relieve pressure and remove the Radiator Cap. Failure to heed this warning could result in severe burns!
- ALWAYS observe the following Safety Procedures when Propane Screed Heater is used:
  - Wrench tighten all fittings. NEVER use grease or lubrication. Do NOT use oxygen with the Heater. Keep cylinder upright at all times. Keep equipment free from dirt and oil.
  - Use a regulator on supply cylinder.
  - Check equipment carefully each time before lighting. ALWAYS light with a striker, NEVER with matches. Do NOT operate in an enclosed area or



# SAFETY

(Continued)



near flammable material. Close all valves when not in use. Comply with all federal, state, and local regulations when operating this equipment.

## Screed Propane Heater - General Safety



**Do NOT smoke in the area around the Power Box Paver when equipped with Propane Burners.**

**ALWAYS make sure a suitable fire extinguisher is readily available.**

**ALWAYS light burner with a striker, NEVER use a match.**

**Burner flame may be invisible in sunlight. Do NOT place burner near your skin or clothing. Severe burns will result.**

- 
1. This equipment is designed to be used only with propane gas.
  2. Wrench tighten all fittings.
  3. NEVER use oil or grease for lubrication.
  4. Do NOT use oxygen with this equipment.
  5. Keep cylinder upright at all times.
  6. Keep equipment free from dirt and oil.
  7. Use a regulator on supply cylinder.
  8. Check equipment carefully each time before lighting.
  9. Always light with a striker, never with matches.
  10. Do NOT operate in an enclosed area or near flammable material.

11. Close all valves when not in use.

12. Comply with all federal, state and local regulations when operating this equipment.

- To ensure continued safe operation, replace damaged or worn-out parts with genuine GEHL service parts, BEFORE attempting to operate this equipment.

## Modifications, Nameplates, Markings And Capacities

- Modifications and additions, which affect capacity or safe operation, shall NOT be performed without the manufacturer's prior written approval. Where such authorization is granted, tags or decals shall be changed accordingly.

## Protective Guards And Warning Devices

- The Paver is fitted with protective Covers over the Engine area in accordance with Industry Standards. They are intended to offer protection to the operator from physical injury. A Horn is provided which can be activated from either side of the Paver.

## Replacement Parts

- To ensure continued safe operation, replace damaged or worn-out parts with genuine GEHL service parts, BEFORE attempting to operate this equipment.



# SAFETY

(Continued)

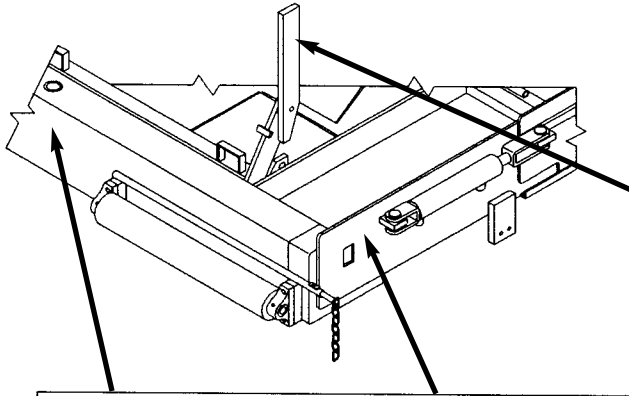

FLOOR SAFETY PROP 210200

	<b>WARNING</b>
	<p>PINCH POINT HAZARD.</p> <p>KEEP CLEAR WHEN MACHINE IS RUNNING. FOLLOW MANDATORY SAFETY SHUT DOWN PROCEDURE AS SPECIFIED IN OPERATOR'S MANUAL BEFORE WORKING ON MACHINE.</p> <p>FAILURE TO HEED COULD RESULT IN DEATH OR SERIOUS INJURY.</p> <p><small>L65927</small></p>

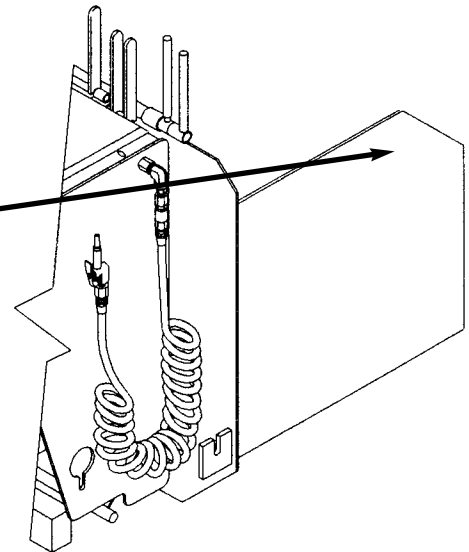

	<b>WARNING</b>
<p>LOADING AND UNLOADING TIP OVER HAZARD</p> <p>PARTIALLY ENGAGE (1/3) BOTH CONTROL LEVERS ALLOWING PAVER TO MOVE VERY SLOWLY UP AND DOWN RAMPS.</p> <p>FAILURE TO HEED COULD RESULT IN DEATH OR SERIOUS INJURY.</p> <p><small>204101</small></p>	

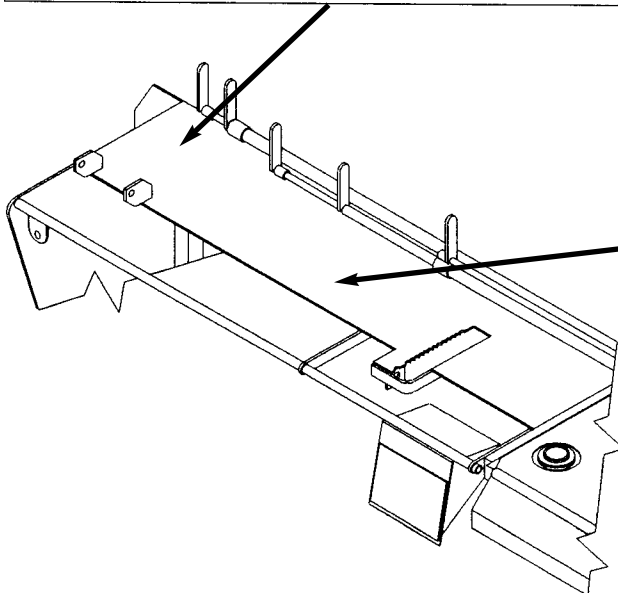

	<b>WARNING</b>
<ol style="list-style-type: none"> <li>BEFORE OPERATING THIS MACHINE READ AND FULLY UNDERSTAND THE OPERATOR'S MANUAL.</li> <li>ALWAYS START AND OPERATE THIS MACHINE FROM THE SCREED PLATFORM.</li> <li>NO RIDERS ALLOWED.</li> <li>NEVER LEAVE SCREED PLATFORM WITH THE ENGINE RUNNING AND DRIVE TRACKS ENGAGED.</li> <li>DO NOT RAISE FLOOR AGAINST TRUCK FRAME.</li> <li>FAILURE TO OBSERVE WARNING COULD RESULT IN DEATH OR SERIOUS INJURY TO OPERATOR OR BYSTANDERS.</li> </ol> <p><small>204100</small></p>	



# SAFETY



(Continued)

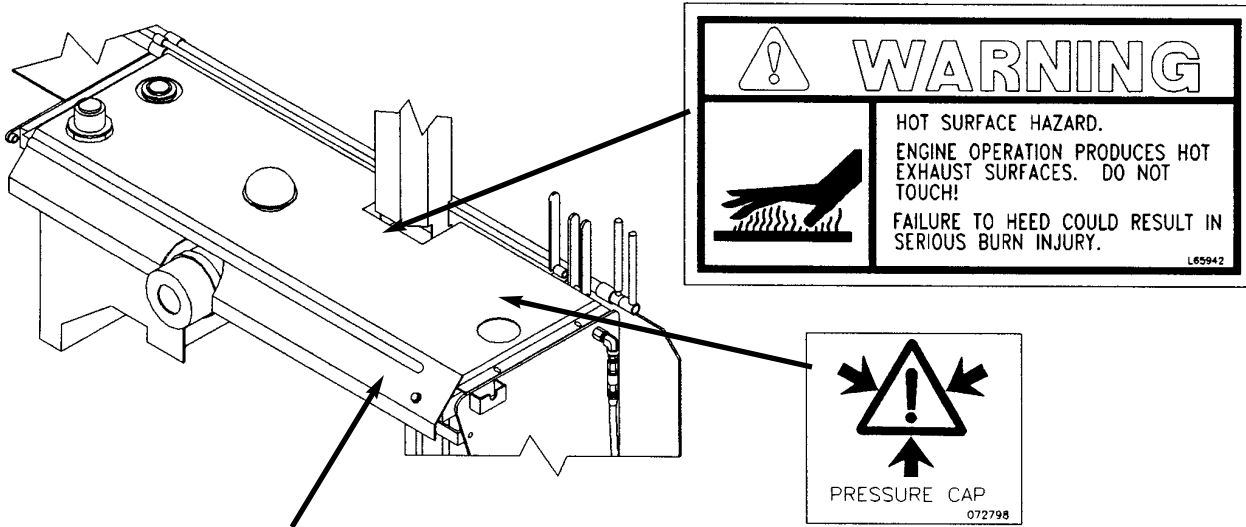

	<b>WARNING</b>
	<p><b>HOT SURFACE HAZARD.</b> ENGINE OPERATION PRODUCES HOT EXHAUST SURFACES. DO NOT TOUCH! FAILURE TO HEED COULD RESULT IN SERIOUS BURN INJURY.</p> <p style="text-align: right;"><small>L65942</small></p>

<b>PRESSURE CAP</b>
<small>072798</small>

	<b>DANGER</b>
	<p>KEEP HANDS OUT. ROTATING COMPONENTS CAN CUT HANDS. FAILURE TO HEED WILL RESULT IN DEATH OR SERIOUS INJURY.</p> <p style="text-align: right;"><small>L65924</small></p>

	<b>DANGER</b>
	<p><b>DON'T BYPASS STARTER SOLENOID</b> FOLLOW RECOMMENDED PROCEDURE IN THE OPERATOR'S MANUAL FOR JUMP STARTING USING THE IGNITION KEY AND START BUTTON. FAILURE TO HEED WILL RESULT IN DEATH OR SERIOUS INJURY.</p> <p style="text-align: right;"><small>L65933</small></p>

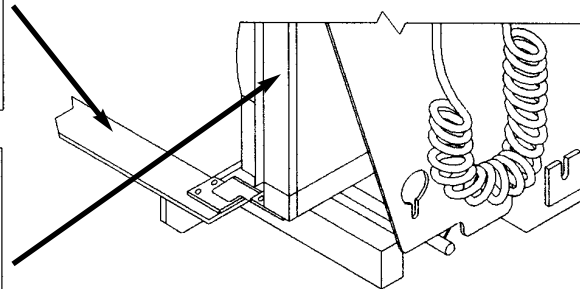

	<b>WARNING</b>
	<p><b>PINCH POINT HAZARD.</b> KEEP CLEAR WHEN MACHINE IS RUNNING. FOLLOW MANDATORY SAFETY SHUT DOWN PROCEDURE AS SPECIFIED IN OPERATOR'S MANUAL BEFORE WORKING ON MACHINE. FAILURE TO HEED COULD RESULT IN DEATH OR SERIOUS INJURY.</p> <p style="text-align: right;"><small>L65927</small></p>



# NOTES

# Chapter 5

## CONTROLS, ATTACHMENTS AND ACCESSORIES

---

### CAUTION

Become familiar with and know how to use ALL safety devices and controls on the Paver BEFORE attempting to operate it. Know how to stop the machine operation BEFORE attempting to operate it. This GEHL Power Box Paver is designed and intended to be used ONLY with GEHL Company accessories or a GEHL Company approved or referral accessory. The GEHL Company can NOT be responsible for operator safety if the Paver is used with an unapproved accessory or attachment.

---

### GUARDS AND SHIELDS

Whenever possible and without affecting Paver operation, Guards and Shields are used to protect potentially hazardous areas. In many places, Decals are also provided to warn of potential dangers and/or to display special operating procedures.

---

### WARNING

Read and thoroughly understand ALL Safety Decals on the Paver BEFORE attempting to operate it. Do NOT attempt to operate the machine unless ALL factory installed Guards and Shields are properly secured in place.

---

### CONTROL INDICATORS & SWITCHES (Figs. 1-5)

The Control Panel on the Backwall Console area contains the following Indicators and Switches:

#### Starter Keyswitch

**Off Position:** When the Key is vertical in the Key switch, power from the Battery is disconnected to the

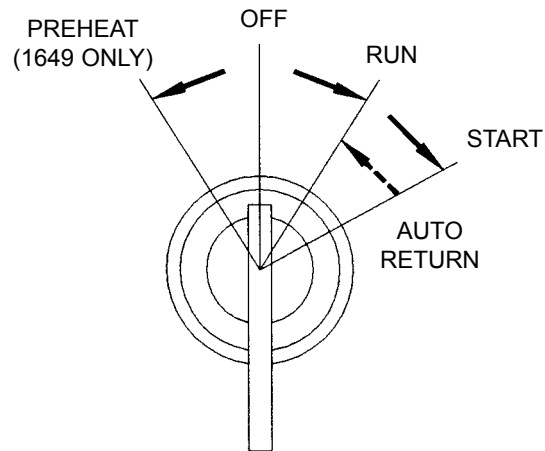

Fig. 1

Control and Instrument Panel electrical circuits. Also, this is the only position in which the Key can be inserted or removed from the Key switch.

**RUN Position:** When the Key is turned one position clockwise from the vertical (OFF) position, power from the Battery is supplied to all Control and Instrument Panel electrical circuits.

**Start Position:** Turn the Keyswitch clockwise two positions from the vertical (OFF) position to activate the Engine Starter. The Keyswitch will return to the RUN position automatically as soon as the Engine Starts.

**NOTE:** The Key MUST always be returned to the OFF position between starting attempts. The Battery Charge and Engine Oil Pressure (Model 1649) Indicators should activate when the key is turned to the RUN position.

**Pre-Heat Glow Plug Indicator (1649):** As an Engine starting aid, pre-heating is required in a cold Engine starting condition. This pre-heating uses Glow Plugs which are activated by rotating the Keyswitch counter-clockwise to the Pre-Heat position.

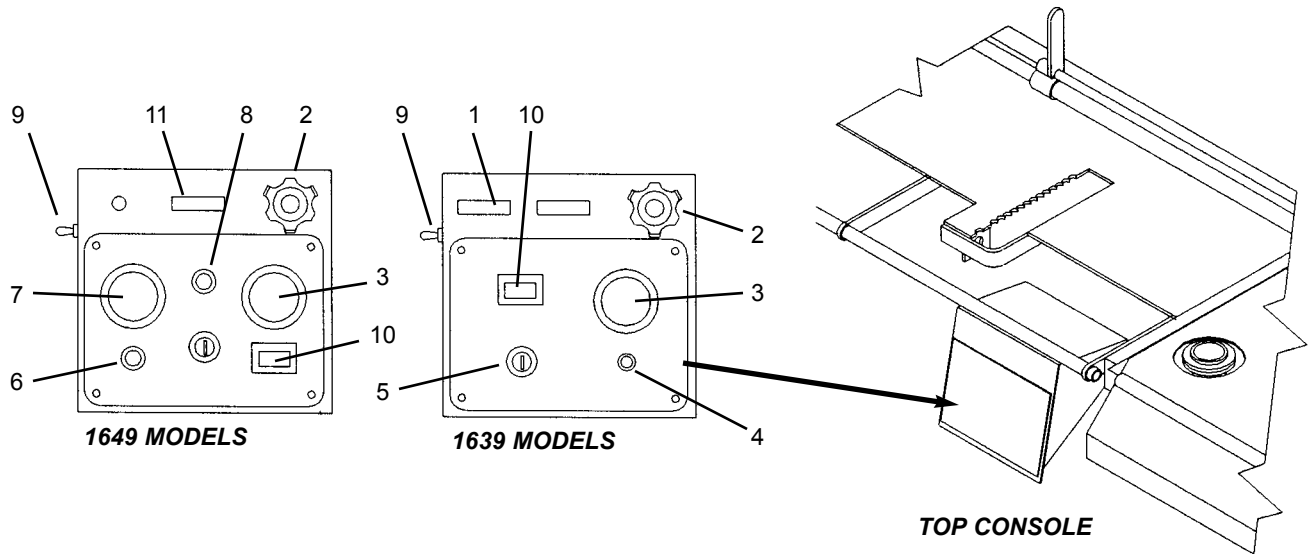
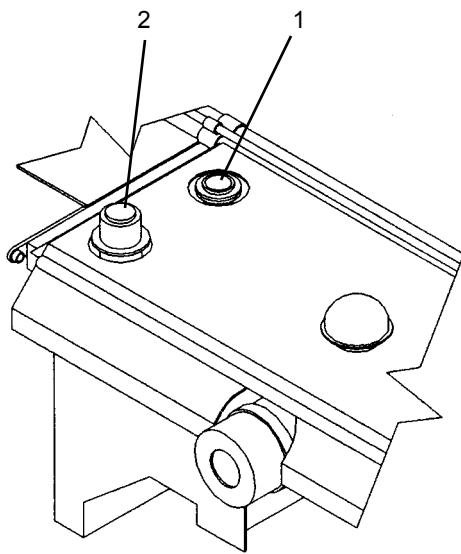
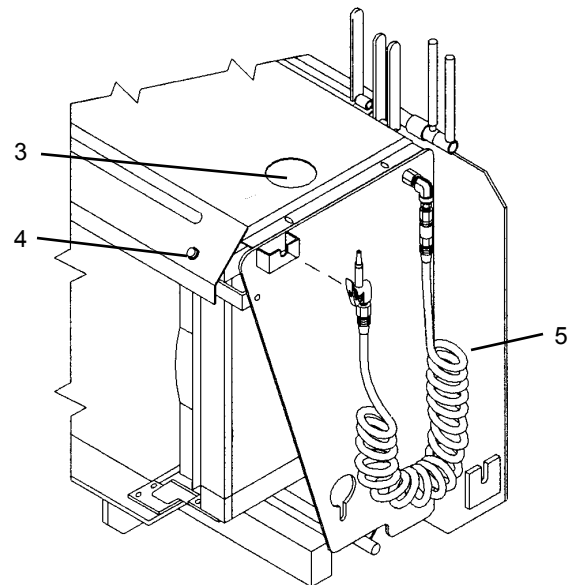

Fig. 2

- |                         |  |                                      |
|-------------------------|--|--------------------------------------|
| <b>1. Choke (1639)</b>  | <b>4. Circuit Breaker (1639)</b>         | <b>8. Engine Oil Pressure (1649)</b> |
| <b>2. Throttle</b>      | <b>5. Keyswitch</b>                      | <b>9. Spray Down Pump Switch</b>     |
| <b>3. Battery Gauge</b> | <b>6. Glow Plug Indicator (1649)</b>     | <b>10. Hourmeter</b>                 |
|                         | <b>7. Water Temperature Gauge (1649)</b> | <b>11. Exhaust Diverter</b>          |



1649 SHOWN



1649 SHOWN

Fig. 3

- |                         |                                       |
|-------------------------|---------------------------------------|
| <b>1. Fuel Gauge</b>    | <b>3. Radiator Fill (1649)</b>        |
| <b>2. Fuel Fill Cap</b> | <b>4. Horn Push Button (Ea. Side)</b> |
|                         | <b>5. Spray Down Hose (Ea. Side)</b>  |

**Engine Throttle:** This controls the Engine speed. Idle position is with the Cable fully in. Operating position is with the cable 1 to 1-1/2 inches out. Release the Lock Ring, depress the red button on the Knob and pull the Knob out to set speed. Rotate the Knob left or right to fine adjust the speed during operation.

**Horn Buttons:** The Horn may be activated from a Pushbutton on the left side or right side of the Console.

**Fuel Level Gauge:** Indicates the amount of fuel remaining in the Fuel Reservoir.

**Battery Charge gauge:** Indicates the condition of the charging system. During normal operation, this Indicator should show minimum registration.

**Coolant Temperature Gauge:** Indicates Engine coolant temperature. Under normal operating conditions, this Gauge should indicate approximately 185°F (85°C).

**Engine Oil Pressure (1649):** This Lamp indicates whether sufficient Engine lubricating oil pressure is present or not. During normal operation, with the Engine running, this Lamp should be OFF. During starting and when the Engine is NOT running, this Lamp will be ON

**NOTE:** *If this lamp comes ON during normal operation with the Engine running, STOP the Engine immediately. After allowing the oil to drain down for a few minutes, check the Engine oil level. Maintain oil level at the FULL mark on the dipstick*

**Circuit Breaker (1639):** The 15 Amp Breaker protects electrical circuits. If it is not in the “depressed position”, the Gauges and Indicators on the Control Panel will not work and the Engine will shut off.

**Hourmeter:** Indicates the operating time of the machine and should be used for keeping up the Maintenance Log chapter of this manual.

**Washdown Sprayer System:** Sprayer is used periodically each day to wash down parts of the Paver which contact asphalt. An asphalt releasing agent is used for this.

---

 **CAUTION**

---

**Do NOT spray releasing agent on a HOT Engine.**

---

**Exhaust Diverter:** Pull this Cable Handle OUT to divert the Engine exhaust down through the Screed. This heats up the Screed bottom surface when paving. Push Handle IN to divert exhaust out through the Muffler.

**Fuel Level Gauge:** The Gauge needle pointer indicates the amount of fuel remaining in the Reservoir.

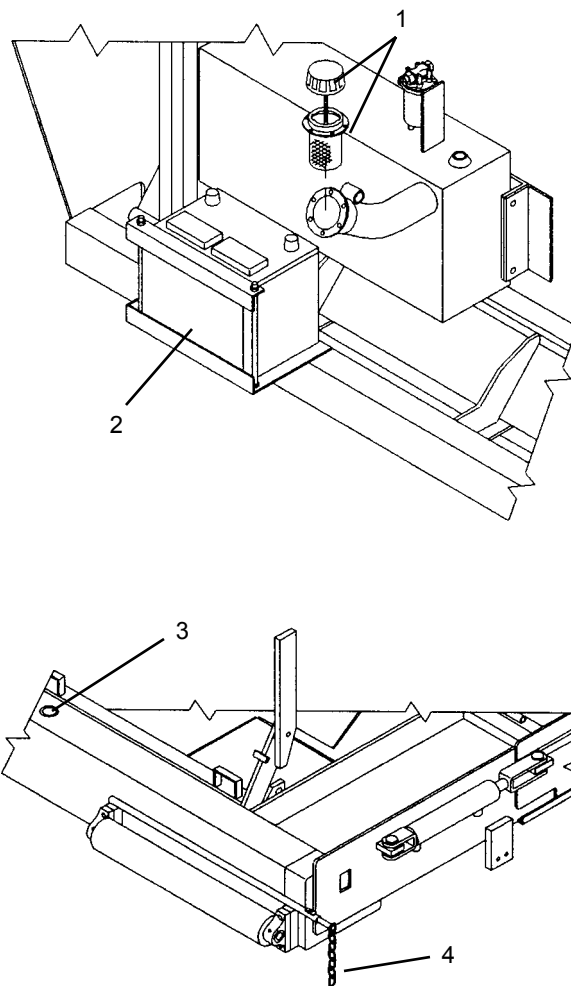

Fig. 4

- 1. Spray Tank Fill Cap
- 2. Battery
- 3. Hydraulic Reservoir Fill Dipstick
- 4. Alignment Guide (Ea. Side)

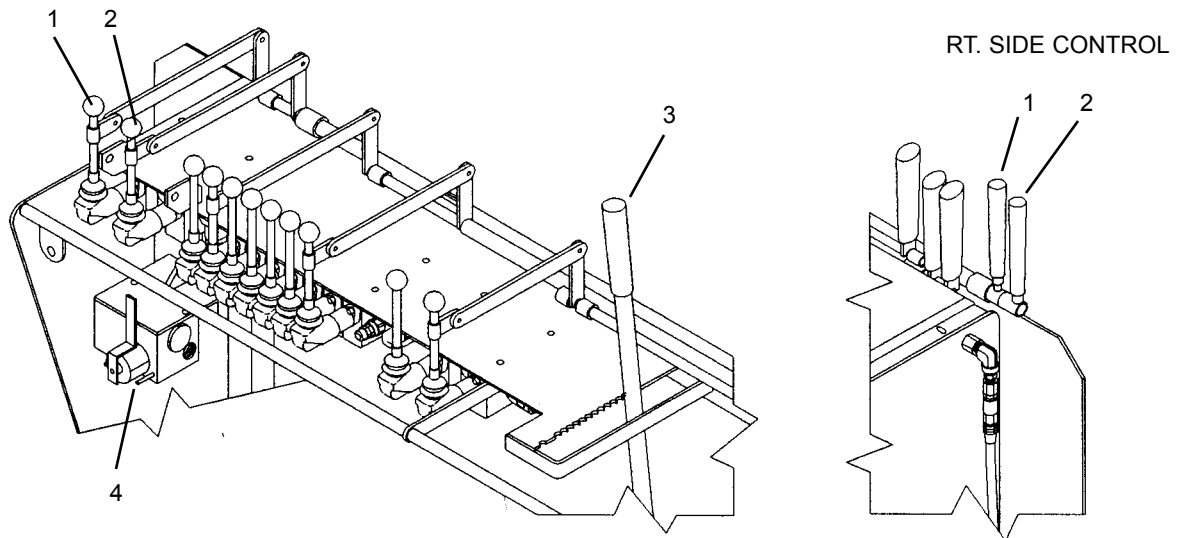

Fig. 5 - Travel Controls

- 1. Left Track Travel
- 2. Right Track Travel

- 3. Pump Speed
- 4. Modular Steering

**Hydraulic Fluid Reservoir:** The Access/Fill Plug on top may be removed to check fluid level..

**NOTE:** Before removing the Access/Fill Plug, allow the fluid to cool for 10-15 minutes. Take a wrench and slowly loosen the Hydraulic Breather Cap on the Backwall Top Console to release system pressure.

**Paving Alignment Guide:** This is adjustable so the Chain will align with a curb or the edge of a previously laid mat of asphalt..

### TRAVEL CONTROLS (Figs. 5-6)

These controls are used to maneuver the Paver around on the jobsite or for road travel. Decals on the Backwall Top Console area provide graphic representation of the various control actions.

**Hydraulic Pump Variable Speed:** This Lever increases or decreases power to the Drive Motors. Push the Lever FORWARD to increase speed, pull BACK to decrease speed. Place the Lever in neutral when not operating.

**Track Travel:** These two Levers control the Track Drive Motors for forward and rearward movement and

also turning of the Paver. Both Levers are mechanically linked to Levers on the right side for control from either side.

**NOTE:** "Right" and "left" are determined from a position standing behind the unit and facing the direction of forward travel. Pivot the machine at slow speeds only.

Movement of the Travel Levers and the expected results are as follows (See Fig. 6):

Move both Levers FORWARD to go forward. Move both Levers REARWARD to go backwards. Move the LEFT Track Lever FORWARD to pivot turn right. Move the LEFT Track Lever REARWARD to pivot turn left.

Move the RIGHT Track Lever FORWARD to pivot turn LEFT. Move the RIGHT Track Lever REARWARD to pivot turn right.

Move both Levers in opposite directions to spin the machine about its center position. Returning both Levers to "neutral" position stops the Drive Tracks.

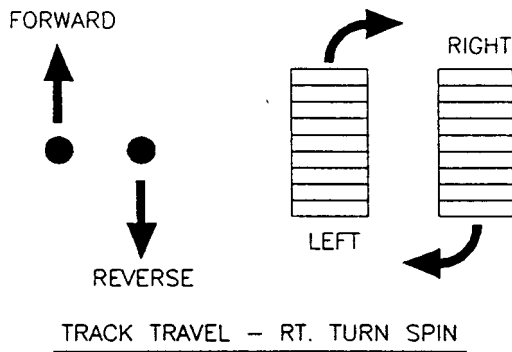
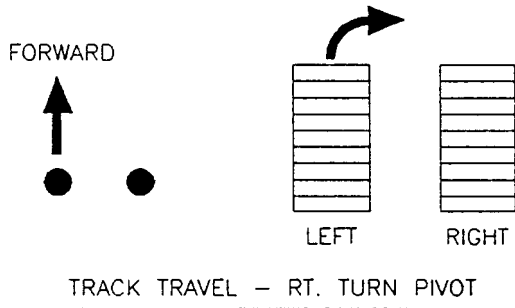
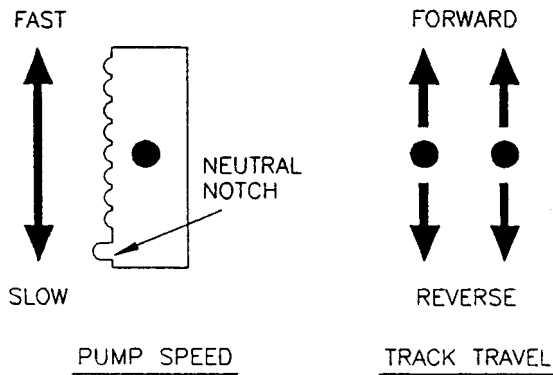

Fig. 6 - Track Travel Action

**Modular Steering:** This control is used for dividing the hydraulic oil to each Drive Motor. It will be necessary to adjust this valve as paving conditions vary.

With the Track Travel Levers both either forward or rearward, set the Pump Speed Lever to "travel" or "pave". Position the Modular Control Lever LEFT to move left and RIGHT to move right. Place the Lever in the CENTER position to move straight ahead.

### HOPPER CONTROLS (Figs. 7-8)

**Hopper Floor:** Move Lever BACK to raise Hopper. Move Lever FORWARD to lower Hopper. This Lever is mechanically linked to a dual control Lever on the right side.

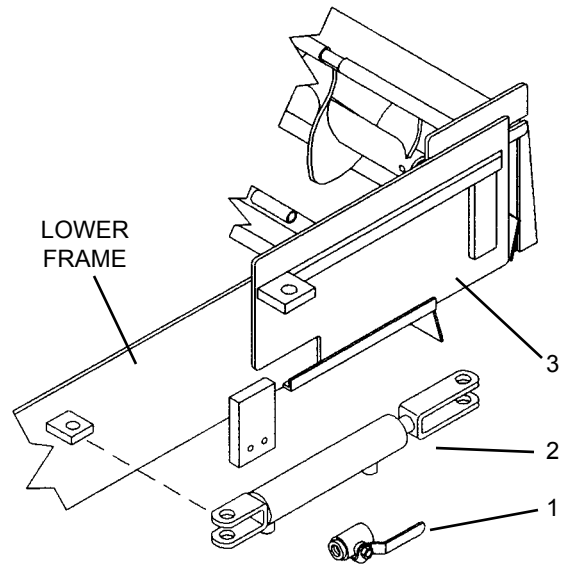

Fig. 7 - Side Gates (Left Side Shown)

1. Shut Off Valve
2. Side Gate Cylinder
3. Side Gate

**Right & Left Flow Gates:** These control flow of asphalt out of the Hopper. One Lever controls each Gate. Move Lever BACK to open Gate. Move Lever FORWARD to close Gate.

**Side Gates:** When paving only 9 ft. wide, the Side Gates should be closed. This is achieved by closing the Shut Off Gates with the Side Gate Valve ON, then turning the Side Gate Valve to the OFF position before re-opening the Shut Off Gate.

**Right & Left Feed Augers:** These are used intermittently only with Extensions "out". One Lever controls each Auger. Move Lever BACK to turn on Auger. Return Lever to "neutral" to turn off Auger. The right Auger Lever is mechanically linked to a dual control Lever on the right side.

### SCREED PLATFORM CONTROLS (Figs. 9-10)

**Up & Down Position:** Move the Lever BACK to lower Screed so that it floats over asphalt feed forming the finished mat surface. Move the Lever FORWARD to raise Screed off mat.

**Vibrator:** This is used to agitate the mat of asphalt passing under the Screed. Move the Lever BACK to

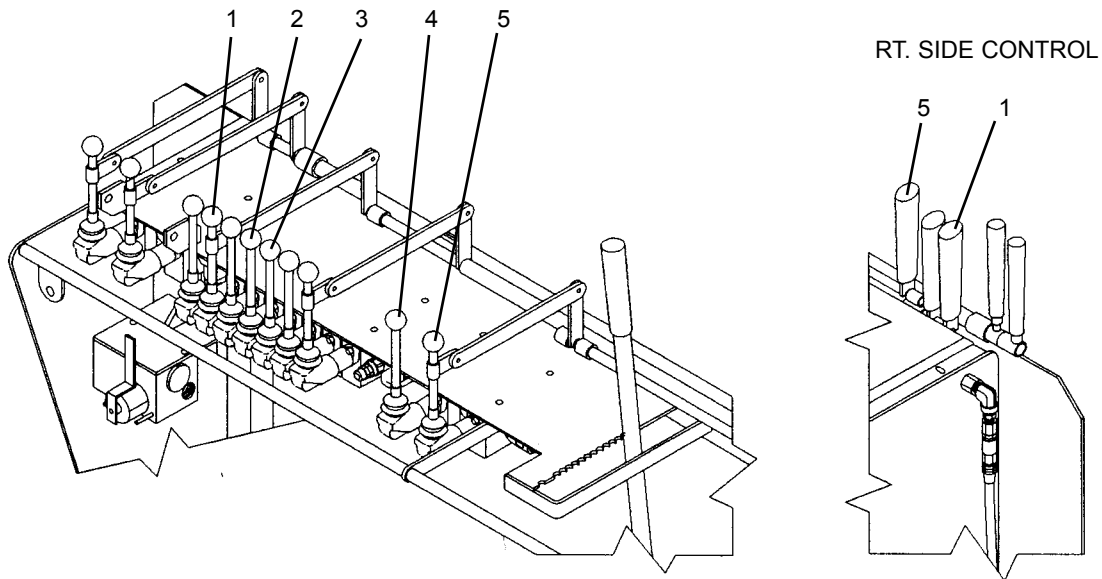

Fig. 8 - Hopper Controls On Backwall Console

- 1. Hopper Floor
- 2. Left Gate
- 3. Right Gate

- 4. Left Auger
- 5. Right Auger

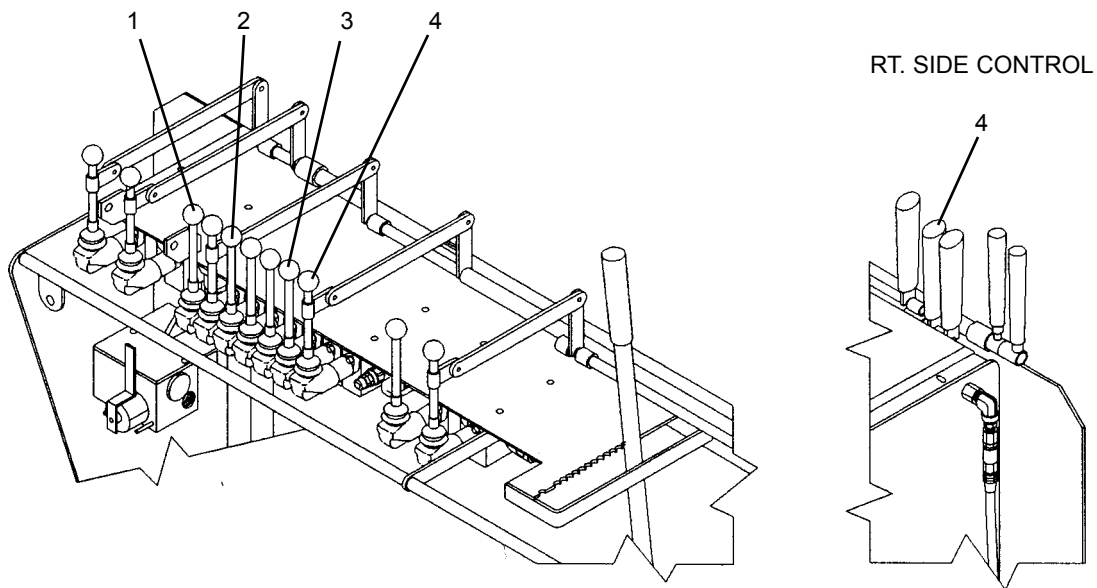

Fig. 9 - Screed Controls On Backwall Console

- 1. Vibrator
- 2. Screed Lift

- 3. Left Extension
- 4. Right Extension

turn the Vibrator on. Allow the Lever to return to “neutral” to turn off the Vibrator.

**Left & Right Extensions:** These allow adjusting and paving width beyond 9 feet. One Lever controls each Extension. Move the Lever FORWARD to shift the Extension inward. Move the lever BACK to shift the

Extension outward. The Right Extension Lever is mechanically linked to Dual Control Levers on both sides of the machine.

**Depth Adjustment:** The Screed has manually operated Adjustment Screws on each end that are used to set the thickness of the asphalt mat. Turn the Screws

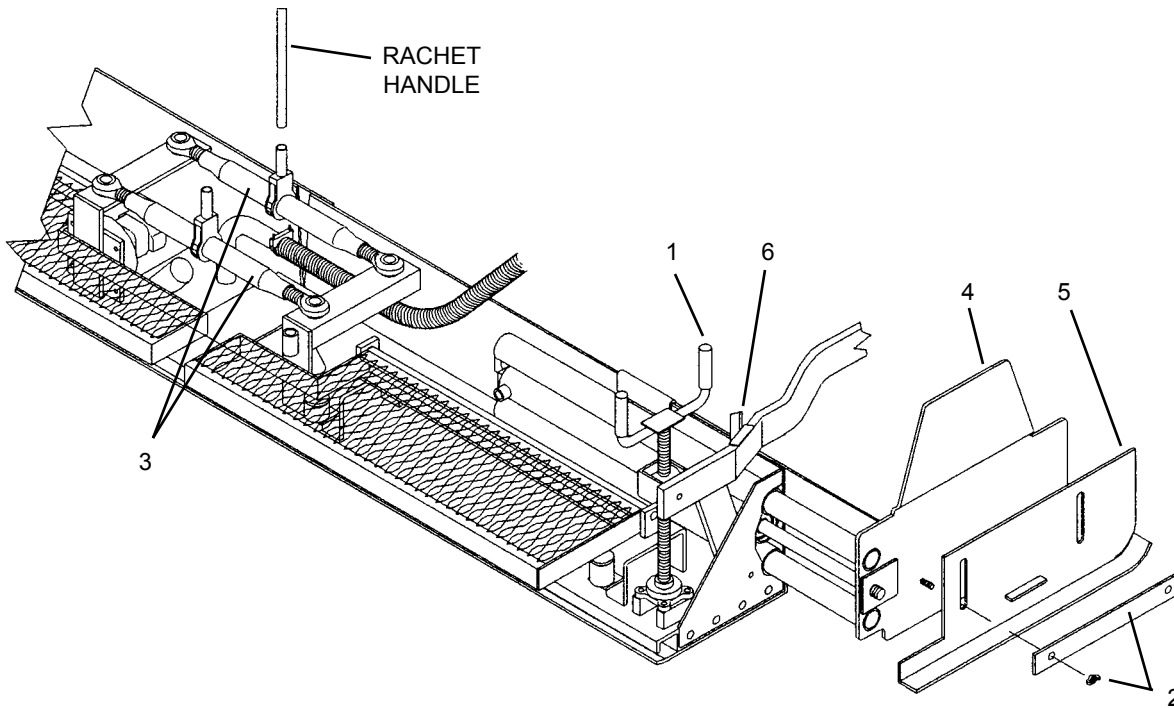

Fig. 10 - Screed Adjustments On Screed (Right End Shown)

- 1. Depth Adjust Screw
- 2. Side Shoe Adjust
- 3. Crown Turnbuckles

- 4. Side Extension
- 5. Side Shoe
- 6. Depth Adjust Indicator

CLOCKWISE to increase the depth. Turn the Screws COUNTER CLOCKWISE to decrease the depth. A depth indicator on each end shows approximate adjustment setting in inches of mat thickness. These indicator numbers are only used as a reference. Actual mat thickness must be measured with a Depth Gauge.

**Crown Adjustment:** This is made with two Turnbuckles at the center of the Screed Platform. Manually turn so screw ends push OUTWARD to decrease the mat crown. Turn opposite so screw ends feed INWARD to decrease the mat invert or valley.

**Side Shoe Plate:** Loosen Wing Nuts for adjustment and re-tighten.

## ACCESSORIES

**NOTE:** All accessories are field installed unless otherwise noted. Information and parts for field installing of all of the accessories will be provided by the Factory or GEHL Paver dealers.

**Cut Off Plates & Baffles:** The following choice of Cut Off Plates & Baffles are available and must be ordered separate by stock number from following list:

Description	Stock Number
6" (152.4mm) for left side	806356
6" (152.4mm) for right side	806357
12" (304.8mm) for left side	806358
12" (304.8mm) for right side	806359
18" (457.2mm) for left side	806360
18" (457.2mm) for right side	806361
24" (609.6mm) for left side	806362
24" (609.6mm) for right side	806363
30" (762mm) for left side	806364
30" (762mm) for right side	806365
36" (914mm) for left side	805460
36" (914mm) for right side	805461

**Bolt On Screed Extension:** The following choice of Extensions are available and must be ordered separate by stock number below:



<b>Description</b>	<b>Stock Number</b>
6" (152.4mm) for left or right side	805464
12" (304.8mm)for left or right side	805466
18" (457.2mm)for left or right side	805468

**Screed Propane Heat Kit:** When desired or where operating conditions require, this kit (without tank) is optional with either 1639 or 1649 models. Order by stock number 805462.

To operate the Propane Heater:

1. Check equipment carefully each time before lighting.
2. Do NOT operate in enclosed areas or near flammable materials.
3. Close the Tank Valve and the valves on both Handles.
4. Slowly open Tank Valve.
5. Adjust Regulator 15-20 psi.
6. Remove one burner from the Burner Tube Support and light with a Striker. Place Burner back into Burner Support Tube.
7. Light the second Burner in the same way.
8. Re-adjust the Regulator to 15-20 psi.
9. Do NOT leave Power Box Paver unattended with burners on. If the flame is extinguished quickly close valves. Wait 5 minutes before you re-light burner to allow fumes to dissipate.
10. When Burners are not in use, close Valve on Tank, crack and close Valves on Handles to release gas pressure in Hoses.

# Chapter 6

## OPERATION & ADJUSTMENTS

### GENERAL INFORMATION

---



**BEFORE starting the Engine and operating the Paver, review and comply with ALL safety recommendations set forth in the SAFETY chapter of this manual. Know how to STOP the Paver BEFORE starting it.**

---

### ENGINE BREAK-IN

Your new Engine does NOT require extensive “break-in”. However, for the first 100 hours of operation, keep the following in mind. Allow the Engine to idle for a few minutes after every cold start. Do NOT idle the Engine for long periods of time. Do NOT operate the Engine at maximum power for long periods of time. Check the oil level frequently and replenish, as necessary.

A special “break-in” oil is NOT used. The oil in the Engine crankcase is the same specified for regular oil changes. Change the oil and replace the oil filter at the intervals specified in the Service chapter. Do NOT add special additives or special “break-in” components to the crankcase.

### BEFORE STARTING ENGINE

Before starting the Engine and running the Paver, refer to the Controls & Accessories Chapter and familiarize yourself with the various operating controls, Indicators and safety features.

### STARTING THE ENGINE

BEFORE mounting the Screed Platform, walk completely around the machine to make sure NO one is, on, or close to it. Let others near the area know you are going to start up and wait until everyone is clear of the machine.

Place all hydraulic function controls and the hydraulic Pump speed control Lever in “neutral” position.

### For 1639 Gas Models

1. Pull the Throttle control 1/4 to 1/2 open.
2. Pull Choke control to full “out” position (close Choke Valve) for cold Engine starts. If re-starting a warm Engine, little or no choking is required..
3. Turn the Key to START position. When Engine starts, release the Keyswitch and it will automatically return to the RUN position.
4. Gradually return the Choke control to full “in” position (open Choke Valve) as Engine warms up and begins to operate smoothly.

### For 1649 Diesel Models

1. Set the Throttle Control to 1/3 open.
2. Turn the Key to the START position. When the Engine starts, release the Keyswitch and it will automatically return to the RUN position.
3. In cold weather starting, first turn the Key counterclockwise to activate Glow Plug. When the Indicator lamp comes on, proceed as in Step 2.

**NOTE:** *Crank the Starter until the Engine is started. If the Engine fails to start within 15 seconds, return the key to the “OFF” position, wait 2 minutes, and try to restart the Engine. Cranking the Engine for longer than 15 seconds will result in premature failure of the Starter.*

After the above steps proceed as follows:

1. Allow a sufficient Engine warm-up time before attempting to operate the Controls.
2. Check that Indicators are in normal condition.
3. Check the color of the exhaust gas. It should be light blue or colorless.
4. Check that there are NO fuel, oil or Engine coolant leaks, and NO abnormal noises or vibrations.

---

 **CAUTION**

**Be SURE the area being used for test-running is clear of spectators and obstructions. For the first time operate the Paver with an empty Hopper.**

---

If the Battery becomes discharged and fails to have sufficient power to start the Engine, jumper cables can be used to obtain starting assistance. Refer to the Jump Starting instructions in the Service chapter of this manual for safe jump-start procedure.

### **FIRST TIME OPERATION**

Make sure the Engine is warm and then go through the following procedures:

Familiarize yourself with various control levers. Raise the Screed. Control the Paver travel forward and backward, then make left and right turns using the track control levers and modular steering control. While stopped, lower the Screed and activate the vibrator. Divert the exhaust down to the Screed. Position the Side Gates and Extensions in and out. Raise and lower the Hopper and turn the Auger Motors on and off.

### **STOPPING THE PAVER**

The following procedure is the recommended sequence for stopping the machine:

1. Place both Track control Levers in “neutral”.
2. Lower the Hopper and Screed to full “down” positions.
3. Place all function control Levers in “neutral”.
4. Move the Throttle to “idle” position.
5. Turn the Keyswitch to “off” position. Always remove the Key and take it with you for security reasons.

### **GENERAL PAVER OPERATION**

#### **Walk Around Inspection**

1. Inspect Suction Hose. Should be firm, not soft.
2. Check for hydraulic leaks.
3. Check Hopper Sides and Floor clearance.

---

 **CAUTION**

**Follow the manufacturer recommendations regarding the use of proper fuel, lubricants and oil.**

**To prevent a fire or explosion, allow the Engine to cool down BEFORE attempting to refill the Fuel Reservoir. A hot Engine could ignite the fuel and burn you. Also, do NOT smoke while refilling the Fuel Reservoir.**

---

4. Inspect the Screed.
5. Check the safety Guards and Covers.

### **Hands-On Check**

1. Check the Fuel Gauge. Fill the Reservoir before paving and as necessary.
  2. Check the Engine Oil Level and replenish as necessary.
  3. Check the cooling air intake on the Radiator (1649) and the Engine cooling fins (1639).
  4. Check the Air Cleaner for cleanliness and make sure that components are tight to prevent intake of unfiltered air.
- 

---

 **CAUTION**

**Clean external surface of Tracks with asphalt releasing agent, using the Wash Down Sprayer. Do NOT spray agent into Tracks immediately before loading or unloading. Wet Tracks can slip and lose traction.**

---

5. Check the fuel Sediment Bowl (1639 Gas Engine) for cleanliness. Check the Hourmeter against Fuel Filter change schedule in the Maintenance Log of this manual.
6. Check the Pump Speed Control Lever for full travel movement.
7. Clean external area of both Tracks (clean 3 to 4 times during working day).
8. Check for and remove as necessary, any asphalt buildup in the Screed Platform exhaust ports (located to the front and rear of each end).



## CAUTION

**NEVER operate the Paver with safety Guards or Covers removed.**

---

9. Check for and remove as necessary, any asphalt buildup inside the Tracks.
10. Make a general inspection of the machine for loose bolts and/or components.
11. Make sure safety Guards and Covers are in place.

If the Paver is found to be in need of repair or in any way unsafe, or contributes to an unsafe condition, the matter shall be reported immediately to the user's designated authority. The machine shall NOT be operated until it has been restored to a safe operating condition.

### PAVING AT THE JOBSITE

The following areas should be "sprayed down" with asphalt releasing agent (use the Spray Down Hose) before paving and four times or more during the work day. These areas should also be cleaned thoroughly after each use of the machine:

Hopper, Augers and Screed (bottom).

Push Rollers.

Hydraulic Fluid Reservoir.

Asphalt Depth Adjustment Screws.

External Track and Sprockets.

Any part of the machine which contacts asphalt.



## CAUTION

**Do NOT spray Tracks before loading or unloading as this could cause loss of traction.**

---

With the Engine warmed up, proceed as follows:

### Positioning The Paver

1. Place Throttle in full "open" position and pull out the Exhaust Diverter Handle. The exhaust will pre-heat the Screed in preparation to lay asphalt mate-

rial. When operating, the Throttle should ALWAYS be at full RPM's. The exhaust can be re-diverted out through the Muffler periodically if desired.

2. Maneuver the Paver into position for laying asphalt with the Track Control Levers.
3. With Paver in position, move the Screed Control Lever to "down" and hold until the Screed Lift Cylinder is fully extended. This permits the Screed to float free. Screed should be lowered onto a starting pad of asphalt or blocks of the desired paving thickness.
4. Manually adjust the Screed Depth Control Screws up or down, as required, to a neutral or free position. Slowly turn the Screws toward the "up" position until a slight amount of tension is felt. The Screed is now set to lay asphalt to the approximate thickness of the starting pad or blocks onto which the Screed has been lowered.
5. Move the right and left Flow Gate Control Levers to the "closed" position and hold until both Gates are fully closed. Set the Alignment guide on each side of the lower front frame.

### Filling The Hopper

6. Have the dump truck back up to the front of the Paver until the truck tires are 1 to 2 inches from the Push Rollers. Then move the Paver forward until the Push Rollers contact the rear tires of the truck. Do NOT raise the Screed.
7. Move the Hoper Control Lever to the "up" position and hold until the Hopper almost touches the frame or dump body of the truck.
8. Signal the truck driver to slowly raise the dump body, allowing asphalt to flow from the truck into the Hopper. Be prepared to lower the Hopper to prevent the truck dump body from striking and damaging the Hopper as the truck dump body is raised. Fill the Hopper with asphalt.
9. Move the Flow Gate Control Levers to the "open" position and hold until Flow Gates are completely open. Asphalt will then gravity feed down to and form a head of asphalt at the leading edge of the Screed.
10. If the area to be paved is level and pushing the truck is desired, place the Hydraulic Pump Speed Control Lever forward approximately 1/3. The

Engine Throttle should be set at full power. Signal the driver to leave the truck in neutral with the dump body raised a sufficient height to allow asphalt to flow slowly but continuously into the Hopper.

## Laying The Asphalt

11. Position the Extension Control Levers to adjust the desired paving width if it is to be more than 9 feet.
12. Move the Track Control Levers to the “forward” position. Continue forward, laying asphalt and pushing the truck approximately 36 to 48 inches. If vibration is desired on the Screed, move the Vibrator Control Lever to “on” position at approximately the same time the Track Control Levers are moved to the “forward” position.
13. Move the Track Control Levers to “neutral” position, stopping the Paver. ALWAYS move the Vibrator Control Lever to “off” position when stopping forward motion of the Paver. It may be necessary to signal the truck driver to stop, if the truck is moving.

**NOTE:** *The truck should NOT be in gear nor should the driver “ride” the brakes. Always advise the truck driver of the procedure for pushing the truck with the Paver.*

14. Check thickness/depth of asphalt in the 36 to 48 inch mat and make necessary adjustment using the Manual Depth Adjustment Screws. Make adjustments up or down gradually to avoid porpoising effect or ripples in the mat as a result of adjusting too much in either direction. If the base on which the asphalt is being laid is on grade and level, only infrequent adjustments will be required after initial asphalt thickness/depth setting is made.

**NOTE:** *Refer to the Troubleshooting chapter in this manual for Paver related, or material delivery and compaction related paving mat application problems.*

15. Move the Track Control Levers to “forward” and continue to pave until the truck is empty and the Hopper is approximately 50% full.

**NOTE:** *Leave a small head of asphalt at the leading edge of the Screed while waiting for the next load of asphalt. If the wait is longer than 10 to 15 minutes, pave 12 to 18 inches further and again leave a small head of asphalt. Repeat in 10*

*to 15 minute intervals using asphalt remaining in the Hopper until next load arrives.*

If the Paver is to be used independently of the dump truck, disregard procedures involving pushing the dump truck for continuous feed while paving (discussed in Steps 10-13) and refer to the following:

16. After the Hopper is fully loaded, signal the truck driver to lower the dump body, stopping the flow of asphalt to the Paver. Simultaneously, the Paver Operator should move the Hopper Control Lever to the “up” position raising the Hopper to avoid asphalt spills from the front of the Hopper.
17. The Paver Operator should then signal the truck driver to move forward to the next place to reload the Paver. This next reloading place may be directly in front of the Paver at a point where the Paver Operator expects the Hopper to be emptied, or another location on the jobsite.

## PRECAUTIONS WHILE PAVING

The right side Control Levers for Auger, Extension, Track and Hopper modes allow a two-man operation to avoid making “blind” joints and to reduce cycle time when paving in two directions.

The Screed Vibrator should be operated ONLY when the Paver is moving to avoid undue compaction in the mat when the Paver is stopped.

Do NOT raise the Hopper against the truck frame or the dump body of the truck.

When pushing a truck on level ground, the truck should NOT be in gear and the truck brakes should NOT be held. The Paver will NOT push a truck with the brakes on.

The two independently operated Augers need ONLY be used when the Extensions are out and then only “off and on”. The Augers are used ONLY for keeping the extended area fully charged with asphalt.

**NOTE:** *Do NOT leave the Augers operating continuously unless required!*

If the Hopper is loaded and the Operator wishes to close the Flow Gates to transport material to an area inaccessible to the truck, or reposition the Paver for the next pass, etc., the following procedure should be employed. ALWAYS lower the Hopper as low as pos-

sible without spilling asphalt. Close one Flow Gate and then the other. Lowering the Hopper substantially decreases the weight being lifted by each Flow Gate. Make sure Screed Extensions are also closed.

Do NOT pull Paver with another vehicle except in an emergency situation (loss of hydraulic power or Engine failure). The Track Control Levers MUST be locked in the “float” position. Remove the Lock Lever and place control levers all the way forward. Replace the Lock Lever. Do NOT pull the Paver backwards! Do NOT pull the Paver at high speeds

When paving uphill, lower the Hopper as needed, placing more weight directly over the Tracks to increase traction.

---

 **CAUTION**

**Do NOT attempt to move HOT asphalt mix with your hands or feet. Contact can cause serious skin burns!**

---

### Handling Asphalt Spills

**NOTE:** ALWAYS remove asphalt spill (large or small) from the path of the Paver Tracks to prevent loose asphalt from getting in the Tracks, or building up on the Sprockets.

The following procedure should be used if the asphalt truck drives away from the Paver when loading or pushing the truck, resulting in a large asphalt spill in front of the Paver:

1. Stop the Paver.
2. Lower the Hopper as low as possible without spilling more asphalt.
3. Close one Flow Gate and then the other.
4. Windrow spilled asphalt material to the center and in front of the Paver, making sure the asphalt is removed from the path of the Paver Tracks.
5. Move the Track Control Levers to “forward”, continuing to pave with asphalt previously gravity fed from the Hopper. As the asphalt head from the Hopper begins to run thin, the windrow asphalt should be at the leading edge of the Screed. If this is the case, continue to pave using the windrow

asphalt, opening both Flow Gates as the windrow asphalt begins to run thin.

If this is not the case, open both Flow Gates approximately 1/3, maintaining a full head of asphalt at the leading edge of the Screed until the leading edge strikes the windrow asphalt. Continue to pave.

**NOTE:** Failure to follow this procedure, in the event of asphalt spills, will result in asphalt buildup and eventual damage to the Flow Gate Cylinders and the Tracks.

### HIGHWAY TRAVEL

For short distance highway travel, attach a SMV (Slow Moving Vehicle) Emblem, purchased locally, to the back of the Paver

**NOTE:** ALWAYS follow ALL state and local regulations regarding the operation of equipment on or across public highways! Also, whenever any appreciable distance exists between jobsites or if operation on public highway is prohibited, BE SURE to transport the Paver using a vehicle of appropriate size and weight.

### TRANSPORTING BETWEEN JOBSITES (Figs. 11-13)

When transporting the Paver, know the overall height to allow clearance of obstructions. Remove or tape over the slow moving vehicle emblem (SMV) if it will be visible to traffic.

---

 **CAUTION**

**ALWAYS abide by the following recommended procedures and guidelines, when attempting to use ramps to load the Paver onto (or unload it from) a truck or trailer. Failure to heed can result in damage to equipment and a serious personal injury or death!**

---

Tie-down slots are provided on the front of the hydraulic reservoir portion of the frame and the lower rear sides of the backwall. Chains can be inserted through these brackets and slots to secure the Paver while transporting.

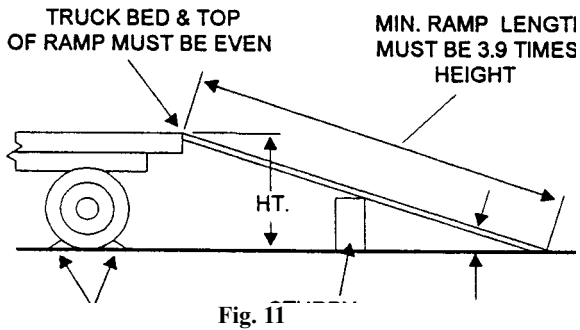

**NOTE:** A matched pair of ramps is required.

1. (Fig. 11) The ramps MUST be of sufficient strength to support the machine. Whenever possible, the use of strong wood covered steel ramps is recommended as well as some type of center supporting block.
2. The ramps MUST be firmly attached to the truck or trailer bed with NO step between the bed and the ramps.
3. Incline of ramps MUST be less than 15 degrees (ramp length MUST be at least 16 feet long).
4. Ramp width MUST be at least 1-1/2 times the Track width.
5. Block the front and rear of the tires on the truck or trailer (if so equipped, engage the parking brake).

## Unloading With Ramps

### CAUTION

**ALWAYS** place the Pump Speed Control Lever in “slow” position when operating the Paver on the truck bed. **ALWAYS** unload the Paver in “forward”.

**Do NOT** walk beside, behind or in front of the Paver during unloading procedures.

1. (Fig. 12) Remove chain binder from tiedown points on the front of the Paver.
2. Start the Engine according to starting procedure in this manual.
3. With Pump Speed Control Lever in “slow” position and Throttle open about 1/4, place the Track

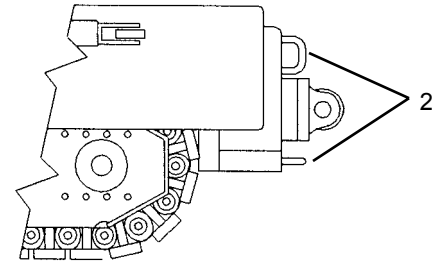
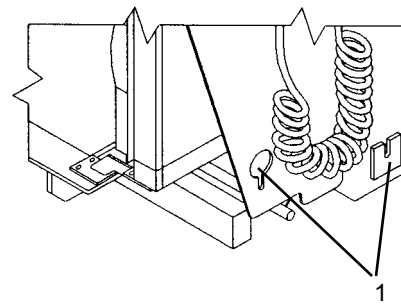

Fig. 12

1. Rear Tiedown Points (Ea. Side)
2. Front Tiedown Points

Control Levers in “reverse”. The Paver will move backwards, releasing tension from the two tiedown chains on the rear of the Paver.

4. (Fig. 12) Remove the chains from both tiedown points on the rear of the Paver.
5. Move the Screed Control Lever to “up” position and hold until Screed is raised completely.
6. (Fig. 13) To avoid bumping the rear edge of the Screed on the bottom of the ramps, turn the Depth Adjustment Screws 7 or 8 turns counterclockwise. This raises the rear edge of the Screed approximately 1 inch.
7. Using the Track Control Levers, align the Paver Tracks with the ramps. When unloading from the rear, rotate and align the Paver Tracks. To rotate place one Track Control Lever in “forward” and the other Lever in “reverse”.
8. Move the Paver forward to the ramps and stop the Paver by placing both Track Control Levers in “neutral” position.

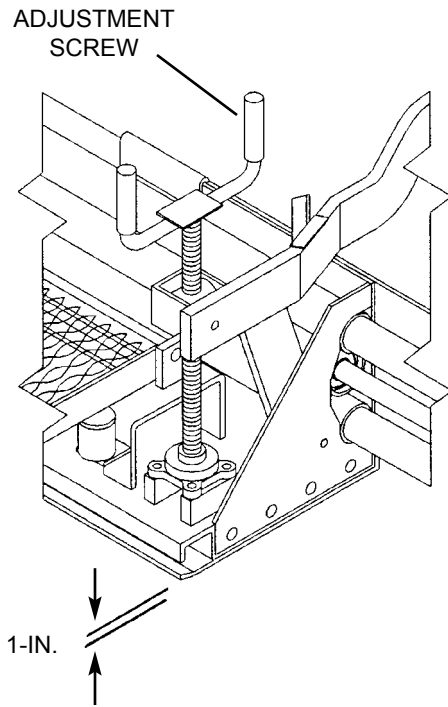

Fig. 13

---

## CAUTION

**NEVER attempt to adjust travel direction (even slightly) while traveling on the ramps. Instead, back up and onto the truck bed, off of the ramps, and re-align the Paver with the ramps.**

---

9. Move the Pump Speed Control Lever to “slow” position. This will prevent the machine from “free-wheeling” down the ramps.
10. The Throttle should be set at 1/2 minimum to full open.
11. Clear the area at the bottom of the ramps of all personnel and other obstructions.
12. Simultaneously place both Track Control Levers in “forward” position, allowing the Paver to travel to the ground.

**NOTE:** *The operator should ride on the Paver with one hand on both Track Control Levers at all times, to maintain positive control of the Paver. Emergency stops are accomplished by placing both Track Control Levers in “neutral” position*

## Loading With ramps

1. Move the Paver to a position that aligns with the ramps so the Paver will be in position to load in reverse. Stop the Paver.
2. Move the Pump Speed Control Lever at 1/3 to 1/2 speed.
3. Place the Throttle Control at full open position.
4. Raise the Screed to the “full up” position with the Screed Control Lever.
5. (Fig. 13) To avoid bumping the rear edge of the Screed on the ramps, turn the Depth Adjustment Screws counterclockwise (7 or 8 turns).
6. Fully engage both Track Control Levers rearward, allowing the Paver to move slowly up the ramps. The operator should ride on the Paver with a hand on both Track Control Levers at all times to stop the Paver if travel is not straight.

---

## CAUTION

**NEVER attempt to adjust travel direction (even slightly) while traveling on the ramps. Instead, back up and onto the truck bed, off of the ramps, and re-align the Paver with the ramps.**

**Do NOT walk beside, behind or in front of the Paver during loading procedures.**

**ALWAYS place the Pump Speed Control Lever in “slow” position when operating the Paver on the truck bed. ALWAYS load the Paver in “reverse”.**

**Check for and remove oil, grease, fuel or other substance on the ramps that may cause the Tracks to lose traction or slip.**

**Do NOT wash down the Paver with asphalt releasing agent just before loading on the vehicle. The Paver Track may become wet and may slip on the ramps.**

---

7. Immediately after the Paver is on the vehicle flat bed, STOP the Paver.
8. Move the Pump Speed Control Lever to “slow” position and reduce the Throttle to “idle” position.



9. Using the Track Control Levers, maneuver the Paver on the trailer or truck for best transporting and balanced position.
10. Rear Loading: After the Paver is on the vehicle bed, place one Track Lever in “forward” and one in “reverse”. The machine will rotate to legal width for transport.
11. Return the Screed to flat position by turning the Depth Adjustment Screws in a clockwise direction (7 or 8 turns).
12. (Fig. 12) Lower the Screed and place chains in the two tiedown points at the rear of the Paver. Drive the paver forward allowing chains to tighten slightly.
13. (Fig. 12) Place a tiedown chain in the tiedown point on the front of the Paver and bind down to the vehicle bed.
14. Turn the Keyswitch to “off” position and remove the Key.

### **In Transit**

If in transit for a few days: (a) Disconnect the Battery.  
(b) Clean all bright surfaces and coat with heavy, very high flash point grease to prevent rusting.

## **THEFT DETERRENTS**

THE CERTAINTY OF APPREHENSION IS A STRONG DETERRENT TO THIEVERY OF CONSTRUCTION EQUIPMENT! GEHL has recorded Part Numbers and Serial Numbers. Users should take as many of the following actions as possible to discourage theft, to aid in the recovery in the event that the machine is stolen, or to reduce vandalism:

1. Remove keys from unattended machines.
2. Attach, secure, and lock all anti.vandalism and anti-theft devices on the machine.
3. Inspect the gates and fences of the vehicle storage yard. If possible, keep machines in well lighted areas. Ask the law enforcement agency having jurisdiction to make frequent checks around the storage or work sites, especially at night, during weekends, or on holidays.
4. Report the theft to the dealer and insurance company. Provide the model, and all serial numbers.
5. Request that your dealer forward this same information to **GEHL** Co.

# NOTES

# Chapter 7

## LUBRICATION

### GENERAL INFORMATION

### CAUTION

**NEVER attempt to lubricate or service this unit when any part of the machine is in motion. ALWAYS BE SURE to exercise the MANDATORY SAFETY SHUTDOWN PROCEDURE (page 10) BEFORE proceeding to lubricate or service this equipment.**

**NOTE:** *The Maintenance Log chapter in this manual has provisions for recording the dates and Hourmeter readings after lubrication or other service has been performed; use those spaces to keep a log for maintaining a current service interval record. Proper routine lubrication is an important factor in preventing excessive part wear and early failure.*





### LUBRICANTS

The following chart lists the locations, temperature ranges and types of recommended lubricants to be used when servicing this machine. Also refer to the separate Engine Manual (provided) for additional information regarding recommended Engine lubricants, quantities required and grades.

**NOTE:** *Refer to Operator Services topic in Service Chapter of this manual for detailed information regarding periodical checking and replenishing of lubricants.*

### GREASING & LUBRICATION

Refer to the following pages for locations and greasing frequencies. Wipe dirt from the grease fittings before greasing them to prevent contamination. Replace any missing or damaged fittings. To minimize dirt build-up, avoid excessive greasing.

<b>Hydraulic System Reservoir</b>  <p>Use SUNVIS 846, or equivalent which contains anti-rust, anti-foam and anti-oxidation additives &amp; conforms to ISO VG46. Capacity: <b>20 Gallons (75.7 liters)</b></p>									
<b>All Grease Fittings</b>  <p>Use No. 2 Lithium-based Grease</p>									
<b>Engine Crankcase Oil</b>  <table> <thead> <tr> <th>Ambient Temperature</th> <th>Grade*</th> </tr> </thead> <tbody> <tr> <td>Below 32°F (0C)</td> <td>SAE 10 or 10W-30</td> </tr> <tr> <td>32-77°F (0-25C)</td> <td>SAE 30 or 10W-30</td> </tr> <tr> <td>Above 77°F (25C)</td> <td>SAE 40 or 20W-40</td> </tr> </tbody> </table> <p>*Service Classification: API - CD/CE/CF-4 Capacity <b>4 Quarts (3.8 liters) - Gas Engine</b> <b>6.9 Quarts (6.5 liters) - Diesel Engine</b></p>		Ambient Temperature	Grade*	Below 32°F (0C)	SAE 10 or 10W-30	32-77°F (0-25C)	SAE 30 or 10W-30	Above 77°F (25C)	SAE 40 or 20W-40
Ambient Temperature	Grade*								
Below 32°F (0C)	SAE 10 or 10W-30								
32-77°F (0-25C)	SAE 30 or 10W-30								
Above 77°F (25C)	SAE 40 or 20W-40								
<b>Torque Hubs Gear Oil</b>  <p>Use API-GL-5 80w90 Capacity (each Hub): <b>17 ounces (481 grams)</b></p>									

**NOTE:** *Always dispose of waste lubricating oils, anti-freeze and hydraulic fluids according to local regulations or take them to a recycling center for disposal. Do NOT pour them onto the ground or into a drain.*

<b>Replacement Filters Chart</b>	
<b>1649 Diesel Engine</b>	
Oil Filter Element	Gehl P/N P700122
Fuel Filter Element	Gehl P/N 123828
<b>1639 Gas Engine</b>	
Oil Filter Element	Gehl P/N P221050
In-Line Fuel Filter	Gehl P/N P217000
<b>Hydraulic System Filters</b>	
Screw-On Filter Element	Gehl P/N 074830
Reservoir Sump Strainer	Gehl P/N 128299
<b>Air Cleaner</b>	
Dry Element (Diesel Eng.)	Gehl P/N 055017
Dry Element (Gas Eng.)	Gehl P/N P700504

## LUBRICATION LOCATIONS

**NOTE:** See the the Service chapter of this Manual for further details.

### Every 10 Hours (or daily)

1. Check Engine Oil Level.
2. Grease Depth Adjustment Screws (2 ea.).

### Every 40 Hours (or weekly)

3. Grease Track Adjuster Yoke (1 per Track).
4. Check Hydraulic Fluid Level.

### Every 100 Hours

5. Change Hydraulic Filters. (2 ea.).

### Every 250 Hours

6. Check Track Torque Hub Fluid Level (2 ea.).
7. Change Engine Oil.

### Every 500 Hours

8. Grease Pump Speed Control Linkage (2 ea.).
9. Change Engine Oil Filter.

### Every 2000 Hours

10. Change Hydraulic Reservoir Fluid.
11. Clean or Replace Hydraulic Sump Strainer.

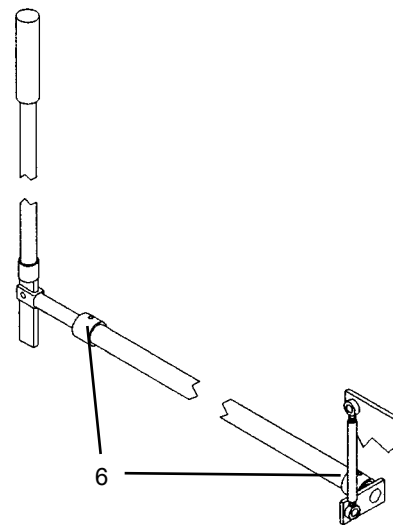

**Pump Control Lube Details**

# BASIC MACHINE LUBRICATION CHART

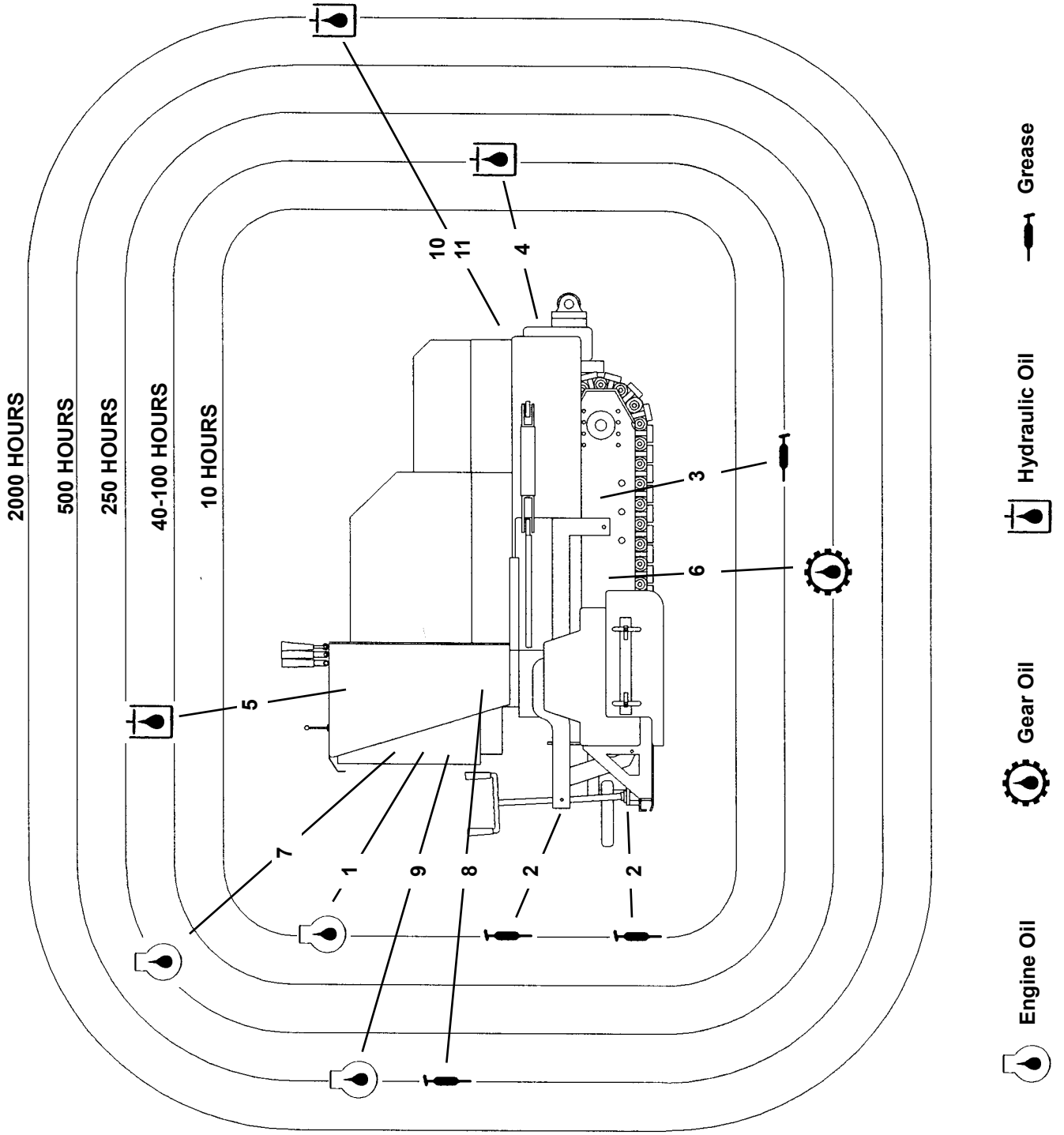

# Chapter 8

## TROUBLESHOOTING

The following Troubleshooting Guide lists potential problems, as well as possible causes and remedies, for the Gehl Paver.

When a problem occurs, don't overlook simple causes. A malfunction could be caused by something as simple as an empty Fuel tank. After a mechanical failure has been corrected, be sure to locate the cause of the problem.



**Do NOT attempt to service or repair major components, unless authorized to do so by your GEHL Dealer. Any Unauthorized Repair will Void the Warranty.**

### GENERAL PAVER PROBLEMS DURING OPERATION

PROBLEM	POSSIBLE CAUSE	REMEDY
<b>Engine operation erratic.</b>	Refer to Engine troubleshooting.	Refer to Engine troubleshooting.
<b>Paver difficult to steer.</b>  <i>NOTE: Normal lead off to one side may be as much as 1 to 2 ft. in 100 ft. of travel under little or no load conditions</i>  <i>Soft or uneven terrain may cause lead off which may be interpreted as steering problems. Actual operating conditions will cause the lead off to change.</i>	One forward/reverse lever not fully engaged.  Linkage for dual controls binding.  Tracks not properly aligned.  Internal leakage in Modular Steer Valve.	Engage lever.  Free up linkage.  Correct alignment.  Replace seals.
<b>Paver slowing down or excessive power loss.</b>  <i>NOTE: Travel speed (0-130 FPM)</i>	Engine not running at rated speed.  Failure of hydraulic system component (Filter, Motor, Pump, etc.)	Disassemble Drive Valve and clean Load Checks.  Check Fuel Filter.  Refer to hydraulic component(s) troubleshooting.
Hydraulic controls stall to freely or won't operate under a load.	Hydraulic system leaks.	Locate leaks and correct.  Repair faulty component.  Refer to hydraulic components troubleshooting

**GENERAL PAVER PROBLEMS DURING OPERATION (Cont.)**

<b>PROBLEM</b>	<b>POSSIBLE CAUSE</b>	<b>REMEDY</b>
<b>Screed not hot enough.</b>	<p>Engine not running at high enough RPM.</p> <p>Excessive exhaust leakage.</p> <p>Exhaust ports at end of Screed plugged.</p> <p>Outside air too cold/or windy.</p>	<p>Refer to Engine troubleshooting.</p> <p>Check for and correct leaks.</p> <p>Clear ports.</p> <p>Use optional propane heater.</p>

**PAVER RELATED MAT PROBLEMS**

<b>PROBLEM</b>	<b>POSSIBLE CAUSE</b>	<b>REMEDY</b>
<b>Wavy Surface (ripples).</b>	<p>1. Fluctuating head of materials.</p> <p>2. Finisher speed too fast.</p> <p>3. Excessive play in Screed mechanical connection.</p> <p>4. Screed riding on Lift Cylinder.</p>	<p>1. Maintain full head of material.</p> <p>2. Reduce speed with the fast-slow lever.</p> <p>3. Replace attaching bolts.</p> <p>Lower Cylinder completely.</p>
<b>Wavy surface (long waves)</b>	<p>See Causes "1, 3, 4".</p> <p>5. Overcorrecting Thickness Control Screws.</p> <p>6. Running hopper empty between loads.</p> <p>7. Sitting long period between loads.</p>	<p>Make more moderate corrections as infrequently as possible.</p> <p>Stop Paver before head of material reaches Screed area.</p> <p>Empty Hopper completely if waiting period lets asphalt cool.</p>
<b>Tearing of mat (full width)</b>	<p>See Cause "2".</p> <p>8. Screed plates worn or warped.</p> <p>9. Cold Screed</p>	<p>Replace Wear Plate.</p> <p>a) Check exhaust ports in Screed. b) Check for exhaust leaks.</p>
<b>Tearing of mat (center streak)</b>	<p>See Causes "8, 9".</p> <p>10. Too little crown in Screed.</p>	<p>Increase lead crown.</p>
<b>Tearing of mat (outside streak)</b>	<p>See Causes "8, 9".</p> <p>11. Too much lead crown in Screed.</p> <p>12. Screed extensions installed incorrectly.</p>	<p>Decrease lead crown.</p> <p>Raise Extension Strike Offs.</p>

**PAVER RELATED MAT PROBLEMS (Cont.)**

<b>PROBLEM</b>	<b>POSSIBLE CAUSE</b>	<b>REMEDY</b>
<b>Mat texture not uniform</b>	See Causes "1, 2, 4, 7-9, 12"	
<b>Screed marks</b>	See Cause "3".	
<b>Screed not responding to correction.</b>	See Causes "2-4".	
<b>Poor pre-compaction.</b>	See Cause "2". 13. Screed riding on Lift Cylinder.	Lower Cylinder completely.
<b>Poor longitudinal joint.</b>	14. Improper joint overlap.	Overlap 2" maximum.
<b>Poor transverse joint.</b>	See Causes "3, 13" 15. Incorrect nulling of Screed.	Increase "pitch" of Screed before starting.

**MATERIAL-DELIVERY-COMPACTION RELATED MAT PROBLEMS**

<b>PROBLEM</b>	<b>POSSIBLE CAUSE</b>	<b>REMEDY</b>
<b>Wavy surface (short waves - ripples)</b>	1. Improper base preparation. 2. Improper rolling operation. 3. Improper mix design (aggregate). 4. Improper mix design (asphalt) 5. Mix segregation. 6. Variation of mix temperature.	Review base installation. Decrease speed. See Asphalt Paving Manual. See Asphalt Paving Manual. Asphalt plant mixing too long. Asphalt plant burners not heating consistently.
<b>Wavy surface (long waves)</b>	See Causes "1, 5, 6" 7. Trucks bumping finisher. 8. Truck holding brakes. 9. Reversing or turning too fast of rollers 10. Parking roller on hot mat.	Stop truck short of Paver and drive Paver to truck. Driver must apply only enough so that truck stays "in Paver". Cycle must be slow but deliberate. Move to cooler surface before parking. Park at 45° angle.



**MATERIAL-DELIVERY-COMPACTION RELATED MAT PROBLEMS (Cont.)**

<b>PROBLEM</b>	<b>POSSIBLE CAUSE</b>	<b>REMEDY</b>
<b>Tearing of mat (full width)</b>	See Causes "3-7".  11. Improper mat thickness.  12. Cold mix temperature..	Mat thickness must be twice size of the largest aggregate.  Check with asphalt plant for hotter asphalt mix.
<b>Mat texture (center or outside streaks)</b>	See Cause "12."	
<b>Mat texture (non uniform)</b>	See Causes "1, 3-6, 11, 12".	
<b>Screed marks</b>	See Causes "7, 8".	
<b>Screed not responding to correction</b>	See Causes "6, 11, 12".	
<b>Auger shadows</b>	See Causes "3-5".	
<b>Poor pre-compaction</b>	See Causes "1, 11, 12".	
<b>Poor longitudinal or transverse joint.</b>	See Causes "2, 12".	
<b>Transvers cracking (checking).</b>	See Causes "1-4, 6, 13".	
<b>Mat shoving under Roller.</b>	See Causes "1-4, 6, 9, 13".	
<b>Bleeding or fat spots in mat.</b>	See Cause "3, 4, 6, 13".	
<b>Roller marks.</b>	See Causes "1, 2, 6, 9, 10".	
<b>Poor mix compaction.</b>	See Causes "1-4, 6, 9, 10, 12, 13".	

## DRIVE AND MAIN CONTROL VALVES

PROBLEM	POSSIBLE CAUSE	REMEDY
<p><b>Incapable of maintaining the load.</b></p>	<p>Internal oil leak at the spool.</p> <p>Oil leaking at relief valve port.</p> <p>Load check poppet or seat damaged (located inside sections).</p>	<p>Replace entire valve housing &amp; spool.</p> <p>Disassemble and clean or replace relief valve.</p> <p>Replace poppet and seat assembly.</p>
<p><b>Spool sticking or does NOT move.</b></p>	<p>Hydraulic oil contaminated.</p> <p>Valve clogged with dirt.</p> <p>Inside of plunger cap filled with oil.</p> <p>Foreign matter at spool internal stop.</p> <p>Pressure too high</p> <p>Lever or link bent.</p> <p>Spool bent.</p> <p>Return spring failing.</p> <p>Return spring or cap misaligned.</p> <p>System oil temperature distribution NOT uniform.</p>	<p>Drain and replace with fresh oil. Also replace Filters.</p> <p>Remove dirt and clean assembly.</p> <p>Replace seal on end of cap.</p> <p>Remove foreign matter or replace entire valve section &amp; spool assembly.</p> <p>Using pressure gauge, readjust pressure.</p> <p>Remove and replace.</p> <p>Replace entire valve assembly.</p> <p>Replace spring.</p> <p>Loosen, realign and retighten.</p> <p>Allow sufficient warm-up for entire system.</p>
<p><b>Oil leaking at seals.</b></p>	<p>Paint sticking at seal.</p> <p>Back-pressure in valve.</p> <p>Dirt in seal.</p> <p>Seal plate has loosened.</p> <p>Seal broken or damaged.</p>	<p>Remove and clean the seal.</p> <p>Replace hydraulic Oil Filter.</p> <p>Remove and clean the seal.</p> <p>Replace valve housing as assembly.</p> <p>Remove and replace seal.</p>
<p><b>Controls feel heavy.</b></p>	<p>Foreign matter in control valve spool.</p> <p>Valve spool sticking.</p> <p>Control linkage lacking lubrication.</p>	<p>Clean control valve.</p> <p>Replace entire valve housing.</p> <p>Properly lubricate.</p>

## HYDRAULIC PUMP AND MOTORS SYSTEM

PROBLEM	POSSIBLE CAUSE	REMEDY
<p><b>System will not operate in either direction</b></p>	<ol style="list-style-type: none"> <li>1. Oil supply low.</li> <li>2. Oil Filters clogged.</li> <li>3. Oil too heavy.</li> <li>4. Control linkage misadjusted.</li> <li>5. Low charge pressure</li> <li>6. Gear pump input shaft damaged.</li> <li>7. Auxiliary pump charge relief valve damaged.</li> <li>8. Gear pump gears worn or scored.</li> <li>9. Gear pump damaged.</li> <li>10. Relief valve stuck open.</li> <li>11. Damaged check valve.</li> </ol>	<p>Check oil level and fill.</p> <p>Replace Filter Element.</p> <p>Use proper viscosity oil.</p> <p>Check to see if control linkage is binding or unfastened</p> <p>See remedy for Causes “6-9”. Pressure should be 300-350, 100 PSI minimum.</p> <p>Inspect gear pump input shaft for damage.</p> <p>Replace or adjust relief valve.</p> <p>Replace defective parts.</p> <p>Disassemble, inspect for damage.</p> <p>Remove, clean or replace.</p> <p>Dissassemble and check if valve is faulty or damaged.</p>
<p><b>System noisy.</b></p>	<ol style="list-style-type: none"> <li>12. Air in system.</li> <li>13. Loose suction line.</li> <li>14. Clogged Suction Filter.</li> <li>15. Internal Pump or Motor damage.</li> </ol>	<p>Low oil level in Reservoir.</p> <p>Tighten fittings or lose hose.</p> <p>Replace Element.</p> <p>Dissassemble, inspect, repair or replace.</p>
<p><b>Sluggish response to acceleration or deceleration.</b></p>	<p>See Cause “12”.</p> <p>See Cause “15”.</p> <ol style="list-style-type: none"> <li>16. Low charge pressure.</li> <li>17. Relief Valve dirty or damaged.</li> </ol>	<p>Also see remedy for Causes “1-3, 13”.</p> <p>See remedy for Causes “6, 7, 9”.</p> <p>Remove, clean or replace.</p>
<p><b>Oil leaking from Pump or Motor.</b></p>	<ol style="list-style-type: none"> <li>18. Defective seal.</li> </ol>	<p>Replace seal and/or complete assembly.</p>

## HYDRAULIC CYLINDERS

PROBLEM	POSSIBLE CAUSE	REMEDY
<b>Insufficient hydraulic Cylinder power</b>	Relief Valve pressure setting decreased.	Readjust Valve pressure setting.
	Cylinder internal oil leakage	Replace seals.
	Cylinder piston or seals defective.	Replace piston or seals.
	Control Valve internal oil leakage.	Replace entire Valve housing.
<b>Hydraulic Cylinder external oil leakage</b>	Cylinder seals defective.	Replace seals.
	Cylinder rod damaged.	Replace rod.
<b>Piston does NOT move smoothly.</b>	Oil temperature is abnormally high.	Lower the oil temperature.
	Air being taken into system.	Replenish oil and retighten suction connections.
	Seals defective	Replace seals.

## ELECTRICAL SYSTEM

PROBLEM	POSSIBLE CAUSE	REMEDY
<b>Starter will NOT turn.</b>	Keyswitch is in OFF or RUN position.	Turn Keyswitch to START position.
	Speed control not in OFF position.	Move speed control to OFF position.
	Faulty wiring and/or terminations, or Fuse open.	Troubleshoot circuit and repair.
	Faulty Starter switch	Replace.
	Battery NOT adequately charged.	Recharge.
<b>Battery discharges and/or will NOT recharge.</b>	Terminal or cables are loose or corroded, Battery is defective, and/or Alternator (or Regulator) defective.	Clean terminals and cables and retighten or replace Battery; have dealer check Alternator (or regulator).
	Battery electrolyte level low.	Replenish with distilled water.
	Alternator defective.	Replace or repair.
<b>Operating Horn, etc. does NOT function.</b>	Fuse blown.	Check cause ,correct and/or replace Fuse
<b>Charge Indicator does NOT activate before Engine starts.</b>	Faulty Alternator	Replace.
	Battery is NOT sufficiently charged.	Recharge.

## ENGINE

PROBLEM	POSSIBLE CAUSE	REMEDY
<b>Engine will NOT turn over.</b>	Starter motor defective or faulty wiring connections.	Replace motor and/or repair wiring connections.
<b>Starter motor has insufficient power to turn Engine over.</b>	Battery is run down, Starter is defective and/or wiring connections are broken or loose.	Charge Battery, repair/replace Starter, and/or tighten connections.
<b>Engine cranks-over but will NOT start.</b>	Fuel Reservoir is empty.  Engine crankcase oil is too heavy.  Engine is cold.	Replenish fuel supply.  Drain and replace crankcase oil with proper viscosity oil.  See OEM Engine Manual.
<b>Engine cuts-out abruptly.</b>	Out of fuel  Fuel Filter is clogged and/or air is trapped in the fuel system.	Replenish fuel.  Clean or replace Fuel Filter and/or de-aerate fuel system.
<b>Engine runs rough.</b>	Fuel Filter is clogged and/or air is trapped in the fuel system.  Air Cleaner is clogged.	Clean or replace Fuel Filter and/or de-aerate fuel system.  Clean or replace Element.
<b>Engine overheats.</b>	Cooling fins blocked.  Crankcase oil level too low.  Exhaust is restricted.	Flush-out dirt, debris.  Add oil as required.  When Engine cools, remove restriction.

# Chapter 9

## SERVICE & STORAGE

### GENERAL INFORMATION

---



**BEFORE** proceeding to perform any Service routines on the Paver, or unless expressly instructed to the contrary, exercise the **MANDATORY SAFETY SHUTDOWN PROCEDURE** (Safety chapter). After service has been performed, **BE SURE** to restore all Guards, Shields and Covers to their original positions **BEFORE** resuming Paver operation.

---

**NOTE:** All Service routines, with the exception of those described under the “Dealer Services” topic are owner-operator responsibilities. All Operator Services described under the hourly subtopics are also referred to on a Decal which is located on the Engine Cover. Refer to the Lubrication chapter of this manual for lubrication information.

**NOTE:** This Service chapter details procedures to follow for making routine maintenance checks, adjustments and replacements. The majority of the procedures are also referred to in both the Troubleshooting and Maintenance Log chapters of this manual. For Engine related adjustments and servicing procedures, **BE SURE** to refer to the Engine Manual provided.

This Service chapter details procedures to follow for making routine maintenance checks, adjustments and replacements. The majority of the procedures are also referred to in both the Troubleshooting and Maintenance Log chapters of this manual. For Engine related adjustments and servicing procedures, **BE SURE** to refer to the separate Engine manual provided.

### PRECAUTIONS

Do **NOT** perform any maintenance or repair without the owner’s prior authorization. Allow only trained personnel to service the Paver.

WARRANTY repairs can only be done by a GEHL Dealer. He will know what portions of the Paver are covered under the terms of the GEHL Warranty and what portions are covered by other vendor OEM warranties.

**NOTE:** Always dispose of waste lubricating oils, anti-freeze and hydraulic fluids according to local regulations or take them to a recycling center for disposal. Do **NOT** pour them onto the ground or into a drain.

### DEALER SERVICES

The following areas of internal components service replacement and operating adjustments should only be attempted by (or under the direction of) an authorized GEHL Paver dealer.

### ENGINE COMPONENTS

All service routines, related to the internal components are precise and critical to proper Engine operation. Special know-how and tools are required for servicing.

**NOTE:** If any area of Engine is suspected of faulty operation, contact your Gehl Paver dealer for further assistance.

### HYDRAULIC SYSTEM COMPONENTS

Valves, Pumps, Motors and Cylinders are also sophisticated assemblies which require special know-how and tools for servicing. All Cylinders are appropriately designed with particular strokes, diameters, checks and hose connection provisions unique to the Paver application requirements. A schematic (located at the end of this chapter) can be used as a guide for troubleshooting and service reference, as required.

Internal service on any of these components should only be attempted by (or under the direction of) an authorized GEHL Paver dealer. WARRANTY repairs can only be done by a GEHL dealer. He will know what portions of the Paver are covered under the terms of the GEHL Warranty and what portions are covered by other vendor warranties.

## ELECTRICAL COMPONENTS

An Electrical system diagram is provided which includes instrumentation, electrical components and switch connections. The schematic (located at the end of this chapter) can be used as a guide for troubleshooting and service reference, as required.

## OPERATOR SERVICES

Some of the operator related services will require access to components located inside the superstructure under shields, hoods and covers.

Choose a clean, level work area. Make sure you have sufficient room, clearances, and adequate ventilation. Clean the walking and working surfaces. Remove oil, grease and Water to eliminate slippery areas. Utilize sand or oil absorbing compound, as necessary, while servicing the Paver.

Before starting inspection and repair, move the Paver onto a level surface, shut down Engine, and release all hydraulic pressure. Always lower the Hopper to “full down” position. If the area under the Hopper requires service, raise the Hopper to “full up” and swing up the two Safety Props. Place all controls in neutral.

Disconnect the Battery and remove the Ignition Key. Remove only guards or covers that provide needed access. Wipe away excess grease and oil.

Excessively worn or damaged parts can fail and cause injury or death. Replace any cracked or damaged part. Care should be taken to assure that all replacement parts are interchangeable with original parts and of equal quality.

Use care NOT to damage machined and polished surfaces. Clean or replace all damaged or painted over plates and decals that can NOT be read.

**NOTE:** *NEVER leave guards or access off when the Paver is unattended. Keep bystanders away if access Covers are removed.*

After servicing, check the work performed, NO parts left over, etc. Install all guards, covers and reconnect the Battery.

---



## WARNING

**Do NOT smoke or allow any open flames in the area while checking and/or servicing hydraulic, battery or fuel systems; all contain flammable liquids or explosive gases which can cause an explosion or fire if ignited.**

**Wear a face shield when you disassemble spring loaded components or work with Battery acid. Wear a helmet or goggles with special lenses when you weld or cut with a torch.**

**When working beneath a raised machine, always use blocks, jack-stands or other rigid and stable supports. Wear appropriate protective clothing, gloves, shoes. Keep feet, clothing, hands and hair away from moving parts.**

**Always wear safety glasses or goggles for eye protection from electric arcs from shorts, fluids under pressure, and flying debris or loose material when the Engine is running or tools are used for grinding or pounding.**

**NEVER weld on Bucket, forks, boom, support frame or overhead guards without the consent of the manufacturer. Special metals may be used which require special welding techniques or have a design which should NOT have welded repairs. NEVER cut or weld on fuel lines or tanks.**

**If repair welding is ever required, BE SURE to attach the ground (-) cable from the welder as close as possible to the area to be repaired. Also remove Battery (+) positive terminal connection before proceeding to weld**

---

<b>Daily or 10 Hours</b>
--------------------------

## SPRAY DOWN ASPHALT CONTACT AREAS

The following areas should be sprayed with asphalt releasing agent before paving, at least four times during operation, and after each use of the Paver.

1. Hopper and Augers
2. Screed (bottom)
3. Push Roller Assembly

4. Hydraulic Fluid Reservoir
5. Asphalt Depth Adjustment Screws
6. Drive Tracks
7. Any other part of the machine which contacts asphalt

**NOTE:** Do NOT spray releasing agent into Tracks as slippage and loss of traction will result.

### CHECK FUEL TANK LEVEL

After operation each day, the Fuel Reservoir should be filled to prevent water from condensing in the Reservoir. To fill, remove the Filler Cap and add fuel.

A Drain Plug is provided in the bottom of the Reservoir for removing condensation and other foreign materials periodically. Open the Plug and allow water and fuel to drain into a container until only clear fuel is flowing from the Reservoir.

### CHECK FUEL FILTER

**NOTE:** The Fuel Filter will require occasional replacement to maintain a clean and adequate fuel flow for maximum Engine horsepower. The frequency of Filter replacement will be determined by the cleanliness of available fuel, the care used in storing fuel supplies and the operating conditions in which the Paver is used.

Small amounts of water can be drained from the 1649 Diesel Engine Fuel Filter. The Drain Petcock should be loosened weekly to drain off water accumulation until clear fuel is flowing from the outlet. A glass sediment bowl on the 1639 Gas Engine should be inspected frequently and cleaned if dirt or water are present. See 100 Hour Service for removal and cleaning procedure.

### CHECK ENGINE OIL LEVEL

With the Paver on level ground, and the Engine stopped for ten (10) minutes or more, remove the Engine Dipstick. Wipe it clean, re-insert it and remove to obtain a reading. If the oil level is down, or below the ADD mark, fill with the required amount of oil to bring the level to the FULL mark. See the Lubricants chapter for the type of oil to use.

### CHECK RADIATOR COOLANT LEVEL (1649 Models)

With the Paver on level ground, remove the Radiator Cap. Add clean Engine coolant mixture of 50/50 water

---

## **WARNING**

**Do NOT remove the Radiator Cap when the Engine is running HOT, or overheated. Coolant is extremely HOT and under pressure and it can burn your skin. Allow sufficient time for the Radiator and Hydraulic Oil Cooler to cool BEFORE relieving the pressure and removing the Radiator Cap.**

---

and Anti-Freeze if the coolant level is below the filler neck. Replace the Radiator Cap securely.

**NOTE:** If the Engine is operated with a loose Radiator Cap, the pressure bypass will NOT work and the Engine will run HOT.

### CHECK ENGINE AIR INTAKE SCREEN & COOLING FINS (Model 1639)

Remove the Top Engine Cover for full access. Remove any debris from the screen and fins area.

### CHECK AIR FILTER ELEMENT (Fig. 14)

This Air Filter contains a single dry Element. Empty the Dust Cup and inspect the Element for holes or clogging. On 1639 Models, squeeze rubber dust unloader once or twice daily to check for possible obstruction. The Element is cleanable, but should be replaced after two cleanings, or after six months. This Element does

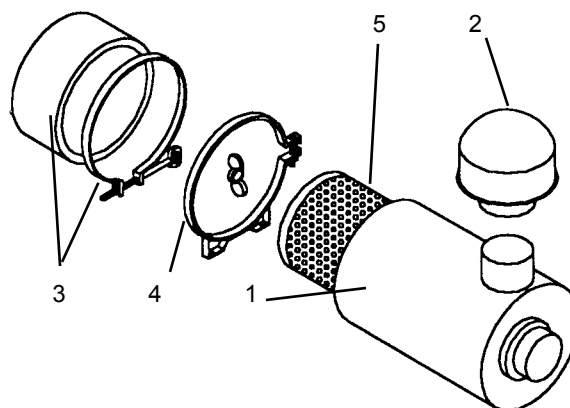

Fig. 14 - Air Cleaner Components

1. Body
2. Inlet Cap
3. Dust Cup & Clamp Ring
4. Mounting Band
5. Element



NOT have a separate safety element so extreme care must be taken when cleaning or inspecting.

## CHECK INSTRUMENTS OPERATION

Allow the Engine to warm up for about five minutes before beginning operation. Indicator lamps should be OFF and Gauges should register normal readings.

## CHECK GENERAL MACHINE OPERATION & CONDITION

Are any Decals missing or damaged? Are all Guards, Shields and Covers in place? Do all controls function smoothly and properly? Are there any abnormal vibrations or noises? Are any hoses or fitting connections leaking? Is the Engine exhaust color normal (light blue or colorless)?

## CHECK FAN BELT (1649)

If the Belt shows wear or cuts, it should be replaced. Order replacement Belt from your Engine dealer. Refer to the Engine manual relative to proper Belt replacement and tension adjustment procedures.

## LUBRICATE DAILY GREASE POINTS

Refer to the Fuels and Lubrication Chapter of this manual for Daily Grease Fitting locations and other related details.

### Weekly or 40 Hours

**NOTE:** *The following service checks should be done at the beginning of each working week and in full conjunction with Dally Service.*

## CHECK HYDRAULIC OIL LEVEL

The fluid **MUST** be cool when checking the Reservoir level, or changing the Filter. By doing this, you will reduce the possibility of overfilling the hydraulic system, and also reduce potential injury due to hot fluid.



## WARNING

**ALWAYS** protect face and eyes whenever a pressure plug or cap is removed. **NEVER** assume that no pressure exists in a pressure vessel or system.

Before removing the Fill Plug, release pressure in the hydraulic system by allowing pressure to bleed-off when loosening the Fill Plug. This can also be done by loosening the Breather Cap on top of the Backwall Console.

**NOTE:** *Be careful when removing the Reservoir Filler Cap so that NO dirt or other foreign matter enters the hydraulic system while the Cap is removed. Do NOT OVERFILL.*

See the Lubricants Chapter of this manual for recommended hydraulic oils.

## CHECK CRANKCASE BREATHER CAP

Refer to OEM Engine Manual for cleaning procedure.

## CHECK BATTERY FLUID & CABLES

Check Cables for corrosion or loose connection. Check to see if fluid level is full in each cell.

**NOTE:** *The Battery on the Paver is warranted by the supplier. See the punch tag on the top of the Battery for warranty information.*

## Handling Battery Safely

The top of the Battery **MUST** always be kept clean. Clean the Battery with a brush dipped in an alkaline solution (ammonia or baking soda and water). After the foaming has stopped, flush the top of the Battery with clean water. If the terminals and Cable connection clamps are corroded or have a buildup, disconnect the Cables and clean the terminals and clamps with the same alkaline solution.

## Jump Starting

If the Paver Battery becomes discharged or does NOT have enough power to start the Engine, use jumper cables and the following procedure to jump-start the Paver Engine.

**NOTE:** *BE SURE that the jumper battery is also a 12 volt D. C. Battery.*

1. Turn the Keyswitches on both vehicles to OFF. Make sure that both vehicles are in "Neutral" and NOT touching.
2. Remove the Battery Filler Caps and make sure that electrolyte solution is up to the proper level. In addition, place a clean cloth over the uncapped filler holes to prevent the electrolyte solution from overflowing.

---

 **WARNING**

Explosive gas is produced while a Battery is in use or being charged. Keep flames or sparks away from the Battery area. Make sure Battery is charged in a well-ventilated area.

**NEVER** lay a metal object on top of a Battery as a short circuit can result.

Battery acid is harmful on contact with skin or fabrics. If acid spills, follow these first aid tips:

1. **IMMEDIATELY** remove any clothing on which acid spills.
2. If acid contacts the skin, rinse the affected area with running water for 10 to 15 minutes.
3. If acid comes in contact with the eyes, flood the eyes with running water for 10 to 15 minutes. See a doctor at once. **NEVER** use any medication or eye drops unless prescribed by the doctor.
4. To neutralize acid spilled on the floor, use one of the following mixtures:
  - a. **1 Pound (0.5 kg) of baking soda in 1 U.S. Gallon (4 liters) of water.**
  - b. **1 Pint (0.4 liters) of household ammonia in 1 U.S. Gallon (4 liters) of water.**

**Whenever Battery is removed from the unit, BE SURE to disconnect the negative (-) Battery terminal connection Cable first.**

---

3. Connect one end of the positive (+) Jumper Cable to the positive (+) Battery Terminal on the disabled vehicle first. Do NOT allow the jumper's positive (+) cable clamps to touch any metal other than the positive (+) Battery terminals. Connect the other end of the positive Jumper Cable to the jumper Battery positive (+) terminal.
4. Connect one end of the negative (-) Jumper Cable to the jumper Battery negative (-) terminal.
5. Make the final negative (-) jumper cable connection to the disabled Paver's Engine Block or Frame (ground) - NOT to the disabled Battery negative post. If making the connection to the Engine, keep

---

 **WARNING**

The **ONLY** safe method for jump-starting a discharged Battery is for **TWO PEOPLE** to carry-out the following process. The second person is needed for removing the jumper cables so that the operator does **NOT** have to leave the Operator's Compartment while the Engine is running. **NEVER** attempt to make the jumper cable connections directly to the Starter Solenoid of either Engine. Start the Engine **ONLY** after making sure **ALL** Controls are in "neutral".

Closely follow the jump-start procedures, in the order listed, to avoid personal injury. In addition, wear safety glasses to protect your eyes and avoid leaning over the batteries while jump-starting.

**Do NOT** attempt to jump-start the Paver if the Battery is frozen as this may cause it to rupture or explode.

---

the jumper clamp away from the Battery, Fuel Lines, or Moving Parts.

**NOTE:** *Twist the Jumper Cable clamps a couple of time on the Battery terminals to insure a good electrical path for conducting current.*

6. Proceed to start the Paver. If it does NOT start immediately, start the jumper vehicle engine to avoid excessive drain on the booster battery.
7. After the Paver is started and running smoothly, have the second person remove the jumper cables (negative (-) jumper cable, first) from the jumper vehicle battery, and then from the disabled Paver while making sure NOT to short the two cables together.

Allow sufficient time for the Paver Alternator to build-up a charge in the Battery before attempting to operate the machine or shut the Engine off. Be **SURE** to discard the cloths and reinstall the Vent Caps removed in Step 2, above.

**NOTE:** *If the Battery frequently becomes discharged, have the Battery checked for possible*

dead cell(s) or troubleshoot the entire electrical system for possible short circuits or damaged wire insulation.

### CLEAN AIR CLEANER ELEMENT (Fig. 14)

Completely wipe the outside of the Air Cleaner Body with a rag or cloth. Blow off excess dirt and dust with compressed air. Dissassemble as follows:

1. Loosen the Clamp Ring and remove the End Cap. Remove the Baffle. Wipe the End Cap and Baffle completely clean. Reassemble the End Cap.
2. Remove the Element Wing Bolt and the Element. Wipe the entire inside of the main Body and Inlet Cap Screen.
3. The paper dry Element may be cleaned only with LOW pressure compressed air , if extremely dirty.

**NOTE:** Do NOT blow air from the “outside to the inside” when cleaning Element. Keep spare Elements on hand to eliminate down time. Refer to reference table in the Lubrication chapter of this manual.

Make sure the clean Element has NO holes or ruptures. Placing a bright light inside the Element and inspecting the outside will show up any holes or tears. Discard the Element if holes or tears are evident.

---

## WARNING

**NEVER** use an Element that is damaged. Severe Engine wear and eventual failure can result if dirt gets through a hole in the Element.

---

Install the Element and reassemble the Air Cleaner. Make sure the large O-Ring is in place between the End Cap and the Main Body.

### LUBRICATE WEEKLY GREASE POINTS

**NOTE:** Weekly lube is to be done in conjunction with daily lube requirements of this chapter.

Refer to the Lubrication chapter of this manual for Weekly Grease Fitting locations and other related details.

## Service Every 100 Hours

**NOTE:** Perform all other service requirements up to this point as well as the following.

### HYDRAULIC FILTERS (Fig. 16)

Remove both Elements and discard. Wipe the sealing-surface on the Mount Head with a clean cloth. Apply a thin coat of clean oil to the new oil filter Gasket. Spin tighten.

---

## WARNING

Hydraulic fluid is HOT during operation. Allow to cool before relieving system pressure by loosening Breather cap on top of the Backwall Console.

---

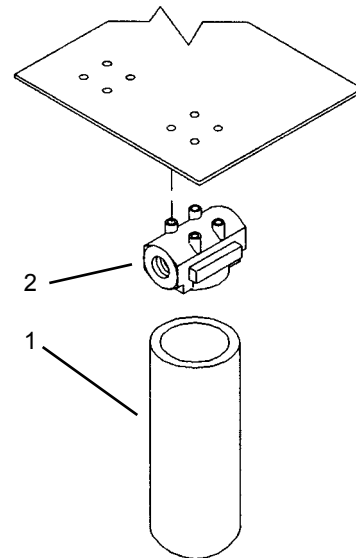

Fig. 15 - Hydraulic Filter Components

1. Filter Element
2. Mounting Head (Bottom Side of Top Console)

### CLEAN FUEL SEDIMENT BOWL (1639)

The fuel supply line connects to a Sediment Bowl on the Gas Engine. To remove the bowl, loosen nut below the bowl, swing bail to one side and twist bowl as it is being removed. Clean screen and bowl thoroughly. Replace gasket if it is damaged or hardened.

## CHECK SCREED BOTTOM PLATE

The bottom plate of the Screed should be inspected for possible wear.

**Service Every 250 Hours**

**NOTE:** Perform all other service requirements up to this point as well as the following.

## CHANGE ENGINE OIL

Change the Engine Oil using the following procedure:

1. With the Engine warm, remove the crankcase Drain Plug. Some plugs are equipped with a magnet to gather metal particles. Completely clean and flush away all metallic filings from the Plug and re-install it.

**NOTE:** DO NOT discharge onto ground. Catch and dispose of per local waste disposal regulations.

2. After new oil has been added, run the Engine at idle speed until the oil pressure light is OFF (1649 models). Check for leaks at the Drain Plug. Re-tighten only as much as necessary to eliminate leakage.

## CHECK TORQUE HUBS OIL LEVEL

With the Hopper raised, position the Track so the Check Plug is in "3 or 9 o'clock" position. Plug is located on the side opposite the Drive Motor. Loosen Plug. If oil appears, re-tighten as level is sufficient.

## LUBRICATE 250 HOUR GREASE POINTS

**NOTE:** This lube is to be done in conjunction with previous lube requirements of this chapter.

**Service Every Season or 500 Hours**

## CHANGE ENGINE OIL FILTER

The Engine Oil Filter should be changed at every other oil change interval. Remove and discard the throw away Filter canister. Wipe the gasket and sealing area of the block with a clean cloth.

**NOTE:** Use only genuine OEM Engine replacement Filters.

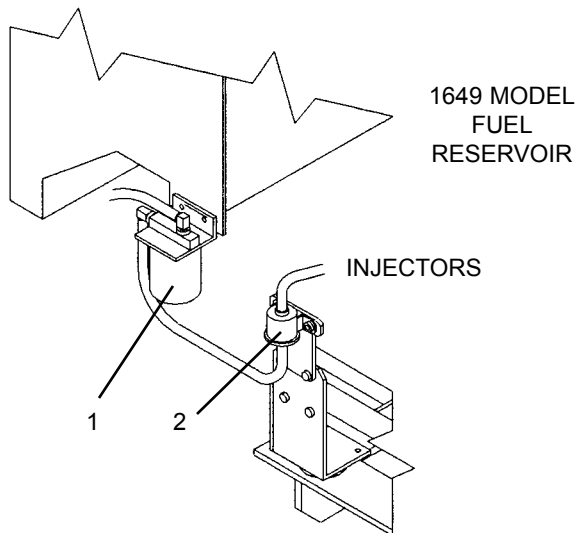
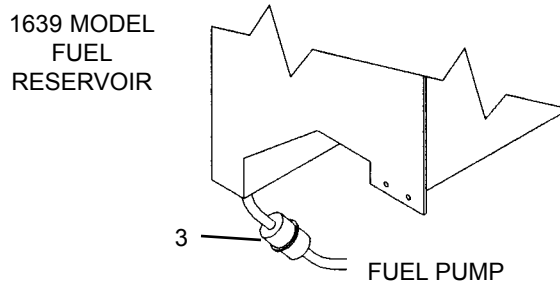

Fig. 16

1. Fuel Filter (1649 Diesel)
2. Fuel Pump (1649 Diesel)
3. In-Line Filter (1639 Gas)

Apply a thin coat of clean oil to the new Oil filter Gasket. Spin tighten. Refill the crankcase with new oil. Follow specifications in the Lubrication chapter for type and viscosity of new oil to put in.

## CHANGE FUEL FILTER (Fig. 16)

The frequency of Filter replacement will be determined by the cleanliness of available fuel, the care used in storing fuel supplies and the operating conditions in which the Paver is used.

**NOTE:** For proper replacement procedures refer to the Engine Manual for your machine.

## Gas Engine (1639 Models) Filters

The Gas Engine has two Filters; (1) an In-Line Filter just off the Fuel Reservoir, and (2) a Sediment Bowl on the Engine Fuel Pump.



## WARNING

**NEVER** service the fuel system while smoking, while near an open flame, or after the Engine has been operated and is hot.

---



## CAUTION

Escaping diesel fuel under pressure can have sufficient force to penetrate the skin. Before applying pressure to the fuel system, **BE SURE** all connections are tight and lines and hoses are **NOT** damaged. Use a piece of wood or cardboard to search for suspected leaks. If injured by escaping fuel, see a doctor familiar with this type of injury at once or gangrene may result.

---

To replace the In-Line Filter, loosen the hose line Clamps and discard the old Filter. Install a new Filter with the “arrow” pointing toward the direction of flow. Check connections for leaks.

### Diesel Engine (1649 Models) Filter

The Diesel Engine has a “screw-on” Canister Filter attached to the Fuel Reservoir, and a remote Fuel Pump mounted on the Engine Mount Bracket. Unscrew the Canister Element and replace with a new one. Lightly oil the rubber gasket on the top of the Filter before installing.

### Fuel Bleeding Procedures

When the Fuel Filter is removed and replaced, or the Engine runs out of fuel, air **MUST** be bled from the system. Refer to the Engine Manual relative to proper bleeding procedures.

If the Engine still will **NOT** start, consult your nearest authorized Engine dealer.

### CHECK FUEL INJECTION SYSTEM (1649 Diesel)

Whenever a faulty or plugged Pump or Injector is indicated, refer to the OEM Engine Manual.

**NOTE:** Only an authorized Engine dealer can perform **WARRANTY** Service on the Engine.

### CHANGE RADIATOR COOLANT (1649 Diesel)

Drain, flush and refill the cooling system as follows:

**NOTE:** *DO NOT* discharge onto ground. Catch and dispose of per local waste disposal regulations..

1. Loosen the Radiator Cap to it's stop. This will release any system pressure. Remove the Cap when all pressure is bled off.



## CAUTION

**Remove the Radiator Cap only when the Engine is cool, or painful burns could result.**

---

2. Open the Radiator Drain Cock. Remove the water jacket Drain Plug from the Engine block. The Engine oil Cooler **MUST** be drained also. When all coolant is drained, flush the system with clean fresh water. Allow the flush to drain completely.

**NOTE:** *DO NOT* discharge onto ground. Catch and dispose of per local waste disposal regulations.

3. Replace all Drain Plugs and tighten the Radiator Drain Cock. Clean out the cooling fins in the Radiator with water pressure or steam.

**NOTE:** *When cold weather is expected, fill the cooling system with a 50-50% mixture of water and ethylene glycol Anti-Freeze. When temperatures are above freezing, water only may be used. Add a summer coolant conditioner to the water to prevent rust and to lubricate the Water Pump.*

4. Inspect the Radiator Cap seal before installing it. Replace it if it appears defective. The pressure Cap and Engine Thermostat work in conjunction with each other to maintain proper Engine cooling.

**NOTE:** *Check the Water Temperature Gauge, every minute or two, after coolant has been changed. Air pockets can form. It may be neces-*

sary to refill the cooling system after a short period of use, as the air will naturally bleed out of the system.

## CHECK EXHAUST SYSTEM

The exhaust provides heating for the Screed surface contacting the asphalt mat, when diverted to that area. Make sure there are no leaks or loose connections.

**Service Every 2000 Hours**

**NOTE:** Perform all other service requirements up to this point as well as the following.

## REPLACE HYDRAULIC FLUID & STRAINER

Clean all dirt and debris off the area where the hydraulic system suction (large) hose connects to the inside wall of the Hydraulic Reservoir.

1. Remove the Drain Plug from the bottom of the Reservoir. Allow all the oil to drain out.

**NOTE:** DO NOT discharge onto ground. Catch and dispose of per local waste disposal regulations.

2. Disconnect the suction hose and remove to Sump Strainer from inside the Reservoir. Inspect the Strainer. If it shows any damage, holes, etc. it should be replaced. Otherwise wash it clean with an industrial solvent, dry with a rag and coat with fresh hydraulic oil. Install the Strainer and reconnect the hose.
3. Flush out the bottom of the Reservoir with clean hydraulic oil and wipe out any debris. Re-install the Strainer, Drain Plug and reconnect the suction hose.
4. Fill the Reservoir with fresh hydraulic oil. Follow specifications found in the Lubrication chapter of this manual.

**NOTE:** Hydraulic fluid and Filters should be replaced anytime contamination is present before the normally scheduled change.

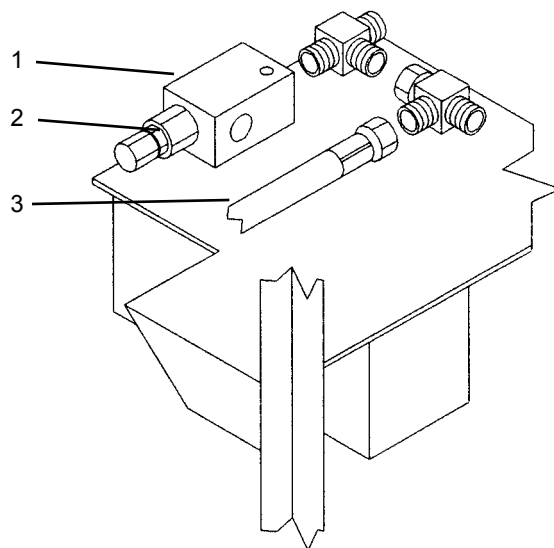

Fig. 17

1. Relief Valve
2. Jam Nut
3. Test Port Hose From Tee Fitting

## TRACK HYDRAULIC PRESSURE ADJUSTMENT (Fig. 17)

Hydraulic pressure on the Front Idler Hub is achieved from an adjustable Relief Valve located on a backwall plate just behind the Screed Lift Cylinder. The pressure must be maintained between 250 PSI minimum and 300 PSI maximum.

If the Tracks are not adjusting correctly, it may be necessary to check this pressure. Install a 0-500 PSI Gauge into the test port hose from the Relief Tee fitting. This Relief Valve connects hydraulically on the return side of the 7-Stack Main Valve. Increase the pressure as follows:

1. Remove the Cap on the top of the Relief Valve and loosen the Jam Nut.
2. Increase the pressure by turning the Allen Screw clockwise.
3. The Engine must be running and at minimum 1/2 throttle.
4. When pressure is corrected, tighten Jam Nut, replace Cap and remove Gauge from test port hose.

**NOTE:** Tracks are NOT adjusted if Engine is NOT running.

## CHECK ENGINE COMPRESSION

Refer to OEM Engine manual.

**NOTE:** Only an authorized OEM Engine dealer can perform WARRANTY Service on the Engine.

## CHECK REPLACE SPARK PLUGS (1639 Gas)

Check periodically. Refer to OEM Engine Manual for replacement procedure.

## LUBRICATE 2000 HOUR GREASE POINTS

**NOTE:** This lube is to be done in conjunction with previous lube requirements of this chapter.

Refer to the Lubrication chapter of this manual for 2000 hour Grease Point locations and other related details.

## STORAGE

If the Paver will NOT be operated for a long period of time, prepare and store it using the procedures as follows.

### BEFORE STORAGE

Perform the following prior to placing the Paver in storage:

1. Wash off the entire machine.
2. Lubricate ALL grease points as described in the Lubrication chapter of this manual.
3. Change Engine oil as outlined in the Service chapter of this manual.
4. Apply grease to all exposed hydraulic cylinder rod areas.
5. Disconnect the battery cable Clamps and cover the Battery or remove the Battery from the Paver and store it separately.

6. For 1649 Diesel Engine only. If the ambient temperature (at anytime during the storage period) is expected to drop below freezing, make sure the Engine coolant is either completely drained from the Radiator and Engine block or that the amount of anti-freeze in it is adequate to keep the coolant from freezing. Refer to the separate Engine manual provided for anti -freeze recommendations and quantities.

## DURING STORAGE

1. About once each month, connect the Battery and check ALL fluid levels to make sure they are at the proper level BEFORE starting the Engine.
2. Start the Engine and allow it to run until it warms up and then move the machine a short distance to help relubricate the internal parts. Run the Engine until the Battery has a chance to recharge and then shut it off.

**NOTE:** If it is desired to operate The hydraulic cylinders at this time, BE SURE to wipe the protective grease (and any adhering dirt) from the cylinder rods prior to starting the Engine. After operating, BE SURE to recoat the cylinder rods with grease if the Paver is going to be returned to storage.

## AFTER STORAGE

After removing the Paver from storage and BEFORE operating it, perform the following:

1. Change Engine oil and Filter to remove condensation or other residuals.
2. Wipe off grease from cylinder rods.
3. Lubricate ALL grease fittings.
4. Review and refamiliarize yourself with all safety precautions as outlined in the Safety chapter of this manual.
5. Follow the starting and warm-up procedures as outlined in the Operation chapter of this manual.

# 1639/1649 Hydraulic Schematic

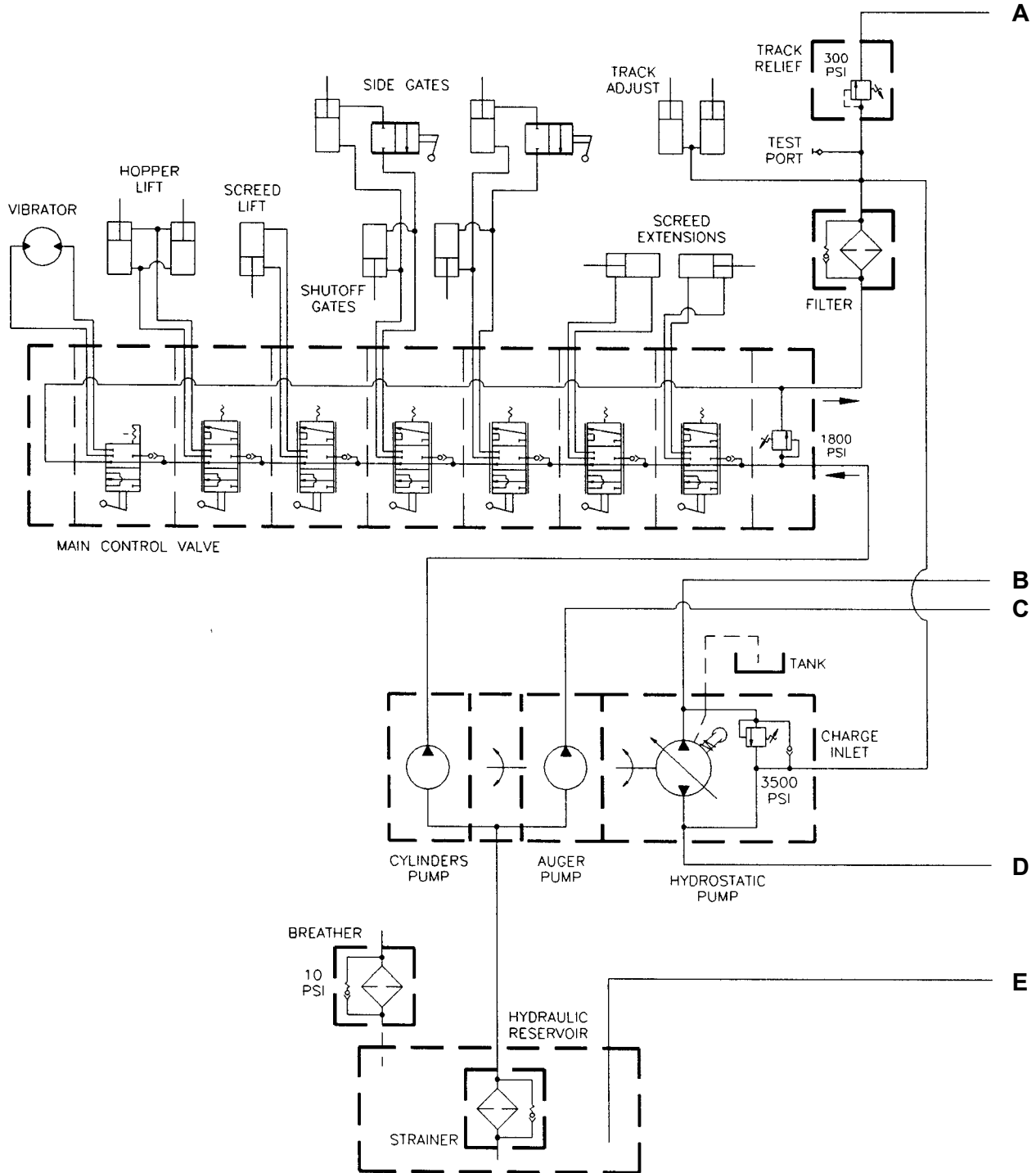



# 1639/1649 Hydraulic Schematic

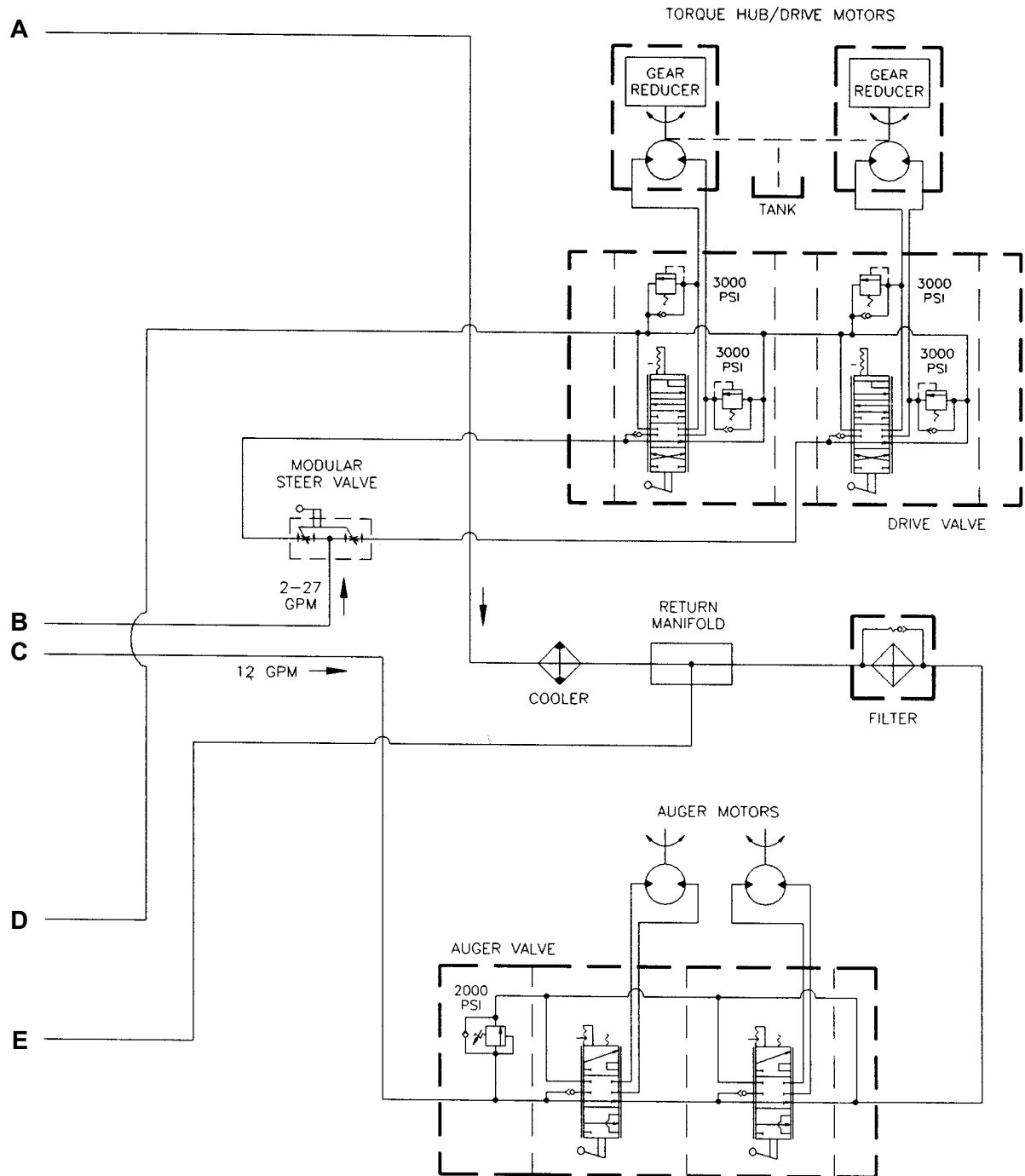

# 1639 Electrical Schematic

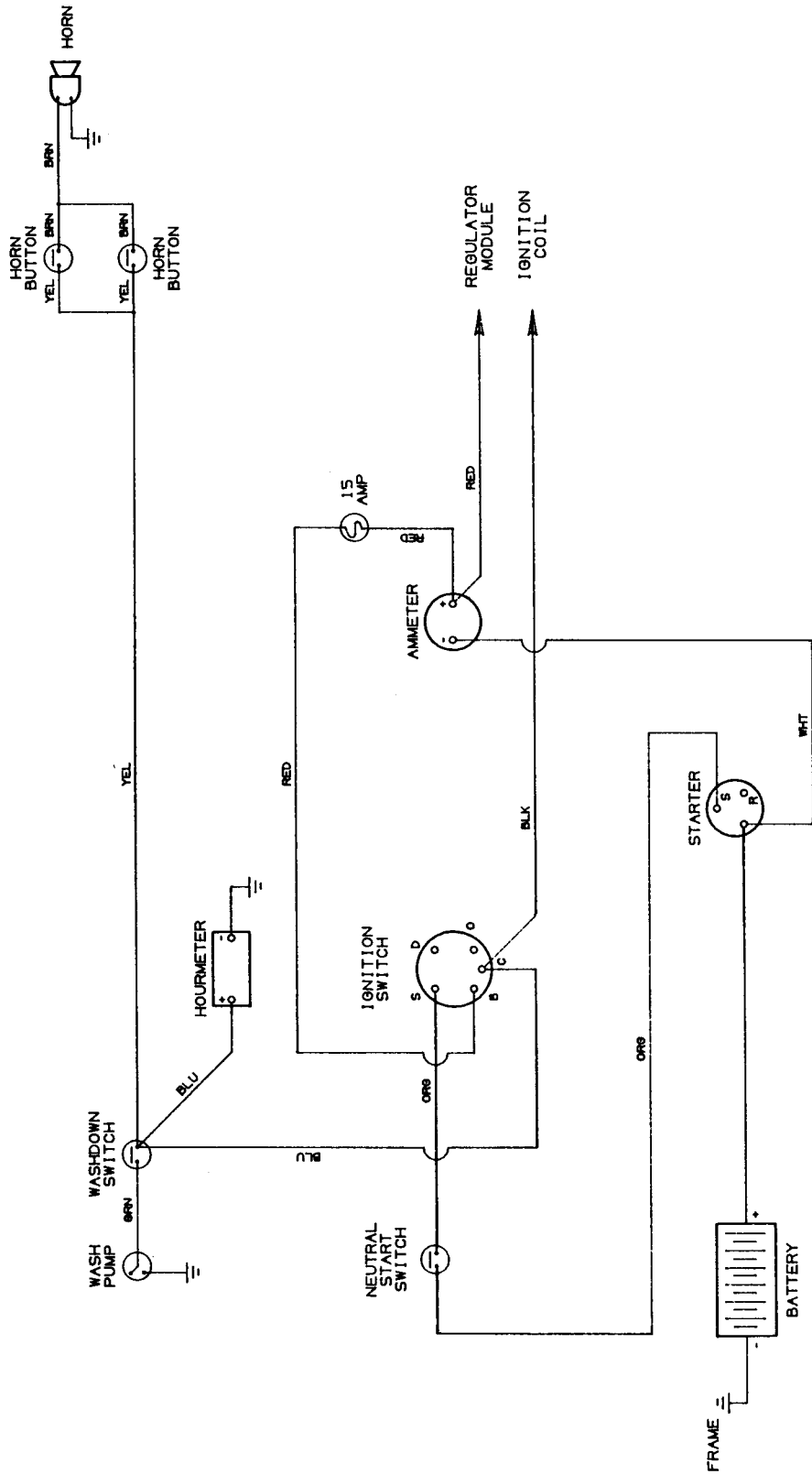

# 1649 Electrical Schematic

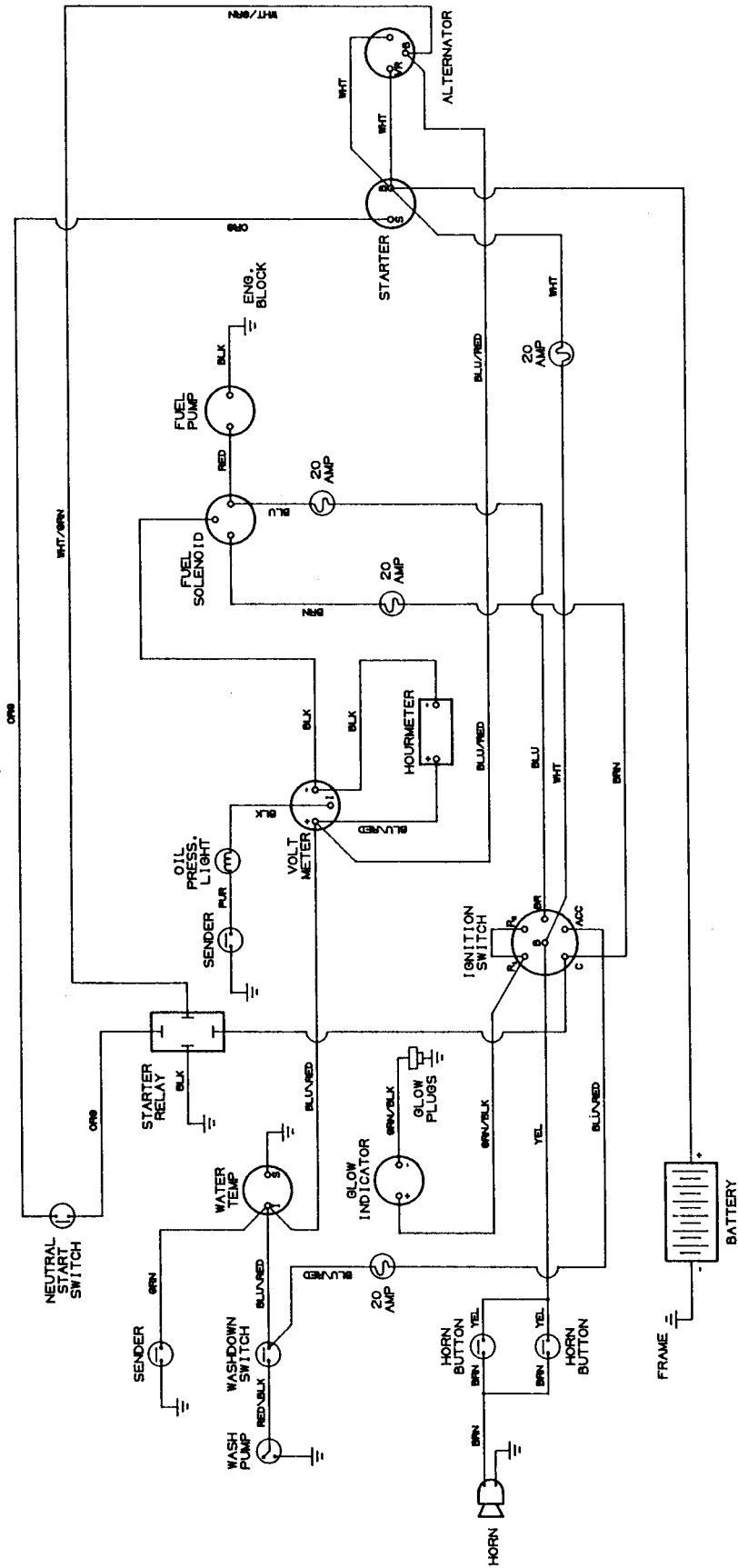

# Chapter 10

## DECAL LOCATIONS

### GENERAL INFORMATION

---



**ALWAYS** read and abide by the **Safety Rules** and information shown on **Decals**. If any **Decal(s)** become(s) damaged, unreadable or if the unit is repainted, the **Decal(s)** **MUST** be replaced. If repainting, **MAKE SURE** that **ALL Decals** which apply to your machine are affixed in their proper locations.

---

Decal Locations information is provided to assist in the proper selection and application of new decals, in the event the original decal(s) become(s) damaged or the machine is repainted.

For correct replacement of decal(s) compare the location illustrations to your machine **BEFORE** starting to refinish the unit. Check-off each required decal using the illustration reference number to find the part number, description and quantity in the list. Refer to the appropriate illustration(s) for replacement location(s).

**NOTE:** Refer to the *Safety chapter of this manual* for the specific information provided on all the various safety decals.

### NEW DECAL APPLICATION

Before applying the new decals, surfaces **MUST** be free from dirt, dust, grease and other foreign material. To apply a solid-formed decal, remove the smaller portion of the decal backing paper and apply this part of the exposed adhesive backing to the clean surface while maintaining proper position and alignment. Slowly peel off the other portion of the backing paper while applying hand pressure to smooth-out decal surface. To apply a die-cut decal, first remove the backing paper. Then, properly orient and position the decal onto the clean mounting surface. After the decal is firmly applied and smoothly pressed down, remove the front covering paper.

### PAINT FINISH

---

**Use this list to order paint for refinishing:**

906213	One Gal. Yellow
906317	One Gal. Charcoal Grey
906323	One Qt. Charcoal Grey
906214	6 (12 oz. Spray Cans) Yellow
906318	6 (12 oz. Spray Cans) Charcoal Grey
L98622	1 (12 oz. Spray Can) Yellow
L98623	1 (12 oz. Spray Can) Charcoal Grey

### COMPLETE DECAL KITS

---

L700528	Model 1639
L700529	Model 1649

*NOTE: Decals can also be ordered individually.*

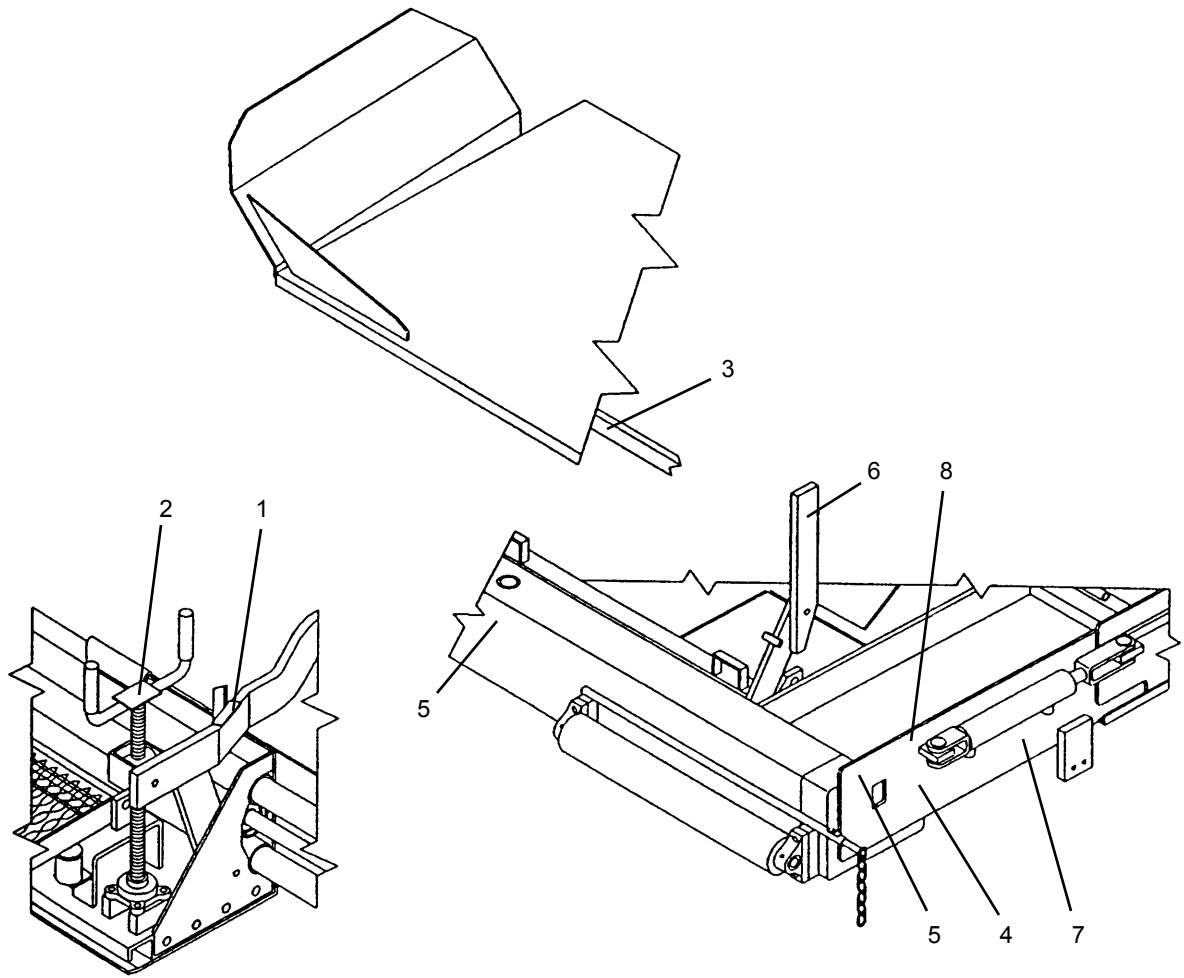

**DECAL LIST - LOWER FRAME, HOPPER & SCREED AREAS**

<b>REF. NO.</b>	<b>DESCRIPTION</b>	<b>1639</b>	<b>1649</b>
1	0-6 Thickness Indicator (2 ea.)	P201400	P201400
2	Up/Down Screed (2 ea.)	P214000	P214000
3	Hydraulic Fluid (1 ea.)	P471425	P471425
4	PowerBox Logo (2 ea.)	P470323	P470323
5	WARNING - Pinch Point (3 ea.)	L65927	L65927
6	Floor Safety Prop (2 ea.)	P210200	P210200
7	On/Off Arrows (2 ea.)	P207300	P207300
8	PowerBox Lettering (2 ea.)	P204030	P204030

**DECAL LIST - BACKWALL AREA**

<b>REF. NO.</b>	<b>DESCRIPTION</b>	<b>1639</b>	<b>1649</b>
1	Fast/Slow Control (1 ea.)	P204015	P204015
2	Hydraulic Oil Under Pressure (1 ea.)	P471310	P471310
3	Diesel Fuel Only (1 ea.)	---	072797
3	Gas Fuel Only (1 ea.)	P205200	---
4	Operator Manual Inside (1 ea.)	L65922	L65922
5	Anti-Freeze (1 ea.)	---	056859
6	RH 5-Position Controls (1 ea.)	P471163	P471163
7	Coolant Under Pressure (1 ea.)	---	072798
8	Horn Button (2 ea.)	P204107	P204107
9	Drive Control w/Float ( 1 ea.)	P212750	P212750
10	WARNING - Load/Unload (1 ea.)	P204113	P204113
11	Operator Instructions (1 ea.)	P277594	P277594
12	WARNING - Operator (1 ea.)	P204100	P204100
13	Auger Control (1 ea.)	P471640	P471640
14	LH 7-Stack Controls (1 ea.)	P204017	P204017
15	DANGER - Rotate Components (1 ea.)	L65924	L65924
16	WARNING - Pinch Point (1 ea.)	L65927	L65927
17	WARNING - Jump Start (1 ea.)	L65933	L65933
18	WARNING - Hot Surface (1 ea.)	L65942	L65942
19	RH Model Number - 1639 (1 ea.)	P471637	---
19	LH Model Number - 1639 (1 ea.)	P471680	---
19	RH Model Number - 1649 (1 ea.)	---	P471638
19	LH Model Number - 1649 (1 ea.)	---	P471681
20	GEHL Lettering, 5.25" (2 ea.)	L66566	L66566
21	Made In USA (2 ea.)	122719	122719
22	Maintenance Chart (1 ea.)	P471815	P471815
23	Filter Reference Chart (1 ea.)	P471731	P471731
24	Asphalt Releasing Agent Only (1 ea.)	P471816	P471816

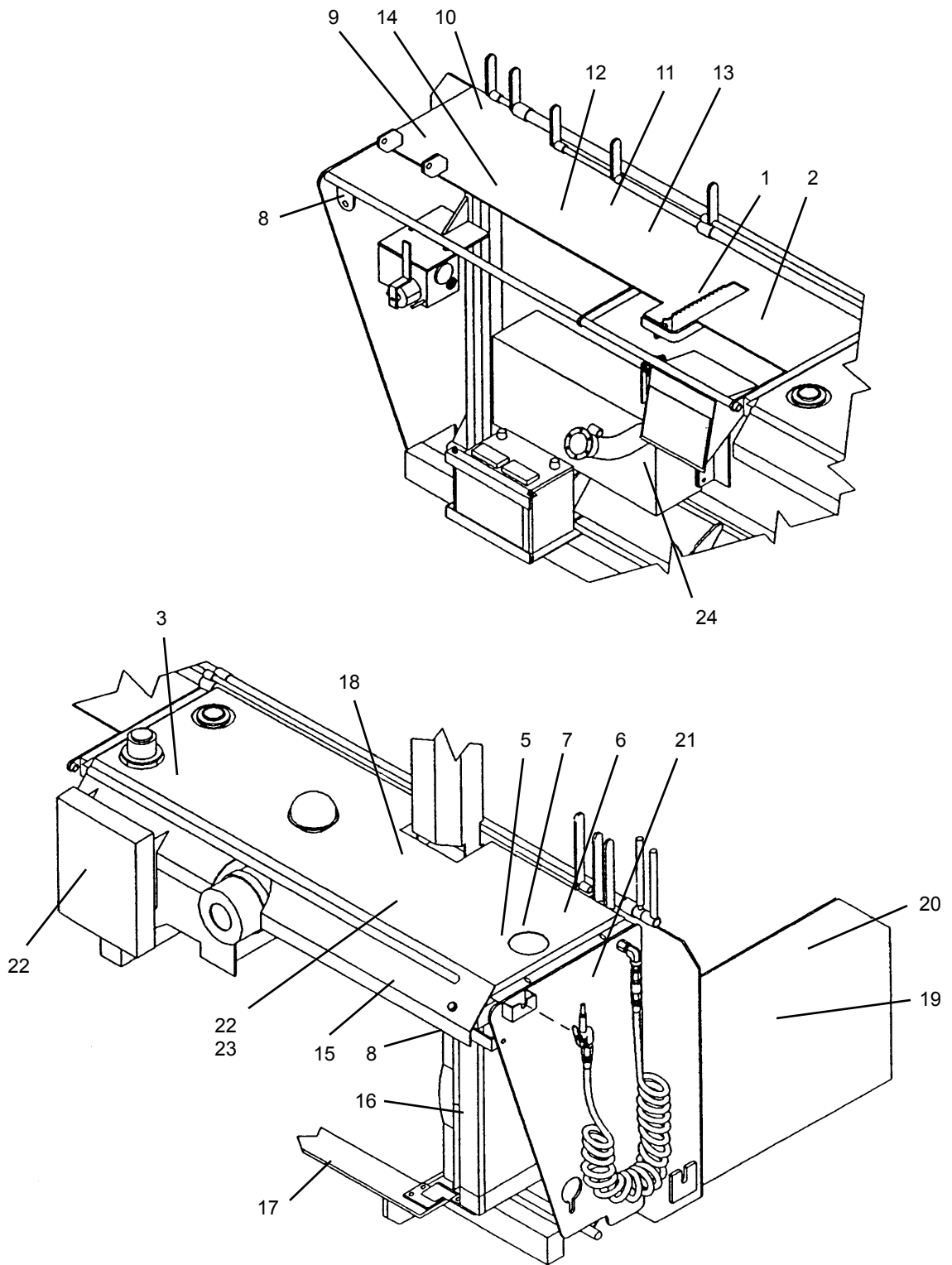

# Chapter 11

## MAINTENANCE

This Maintenance Interval Chart was developed to match the Service chapter of this manual. Detailed information on each Service Procedure may be found in the Service chapter. A Maintenance Log follow the Interval Chart for recording the Maintenance Procedures performed. Recording the 10 Hour (or Daily) service intervals would be impractical and is therefore not recommended.

**NOTE:** *Under extreme operating conditions more frequent service than the recommended intervals may be required. You must decide if your actual operation requires more frequent service based on your use.*

### MAINTENANCE INTERVAL CHART

SERVICE PROCEDURE	Every 10 Hours (or Daily)	Every 40 Hours (or Weekly)	Every 100 Hours
Check Fuel Tank Level	●		
Check Fuel Filter	●		
Check Engine Oil	●		
Check Air Intake Screen/Coolant Fins (1639)	●		
Check Radiator Coolant Level (1649)	●		
Check Fan Belt Tension (1649)	●		
Check Instruments Operation	●		
Check General Machine Operation & Condition	●		
Check Air Filter Element	●		
Lubricate Appropriate Grease Points	●	●	
Change Engine Oil & Filter - <i>initial 50 hours</i>		●	
Check Hydraulic Oil Level		●	
Check Crankcase Breather Cap (1639 only)		●	
Check Battery		●	
Clean Air Filter Element ( <i>Change after two cleanings</i> )		●	
Clean Fuel Sediment Bowl (1639)			●
Check Screed Bottom Plate Wear			●
Change Hydraulic Filter Elements			●









# Index

## A

- Accessories, 22
- Adjustments
  - Screed Platform, 21
  - Track Pressure, 52
- Air Cleaner
  - Check, 46
  - Cleaning & Service Element, 49
- Anti-freeze, *See* Radiator

## B

- Battery
  - Charging Gauge, 18
  - Service, 47
- Battery Cables, cleaning, *See* Battery

## C

- Capacities, 4
- Checklists, delivery, 7
- Controls,
  - Engine, 16
  - Travel, 19
  - Hopper, 20
  - Screed Platform, 20
- Cylinders
  - Servicing, 44
  - Troubleshooting, 42

## D

- Dealer Services, 44
- Decal Locations, 58
- Decals, applying new, 58
- Dimensions, 4
- Drain Cock, for draining coolant, 51

## E

- Electrical Components, servicing, 45
- Electrical Schematics, 56
- Electrical System
  - Characteristics, 45
  - Controls & Indicators, 17
  - Troubleshooting, 42

## Engine

- Clean Air Intake Screen, 46
- Description, 5
- Oil Pressure Indicator, 17, 18
- Starting, 24
- Temperature Gauge, 17, 18
- Troubleshooting, 43
- Engine Oil
  - Changing, 50
  - Check Level, 46
  - Recommended Grades, 33
- Engine Oil Filter, replacing, 50
- Exhaust System, check, 52

## F

- Fan Belt, 47
- Features, *See* Specifications & Accessories
- Fuel, *See* Separate Engine Manual
- Fuel Filter
  - Check & Drain Water, 46
  - Replacing, 50
- Fuel Gauge, 17, 18
- Fuel Sediment Bowl, Clean, 49

## G

- Gauges, functions, 18
- Grease Fittings
  - Locations, 34
  - Types of grease to use, 33

## H

- Hourmeter, 17
- Hydraulic Components
  - Servicing, 44
  - Troubleshooting, 40
- Hydraulic Oil
  - Change, 52
  - Check level, 47
  - Recommended type, 33
- Hydraulic Oil Filters, replacing, 49
- Hydraulic Oil Sump Strainer, replacing, 52
- Hydraulic Pressures, Test Port, 52
- Hydraulic Schematic, 54

## I

Identification Numbers, 1  
Ignition Switch, See Keyswitch  
Index, 65  
Indicators, 17,18  
International Symbols, Inside Front Cover  
Introduction, 2

## J

Jump Starting Battery, 47

## K

Keyswitch, 16

## L

Loading, 30  
Lubrication, 33  
    See also Service  
    Locations , 34

## M

Maintenance Log, 62  
**Mandatory SAFETY Shutdown Procedure, 10**

## O

Oils, See Lubrication  
Operation, 24  
Operator Services, 45  
Operator's Manual, storing, 2

## P

Paver,  
    Identification, 3  
    Starting, 24  
    Stopping, 25  
Paving at jobsite, 26  
Pump, delivery rates, 5  
Paint, refinish, 58

## R

Radiator  
    Check coolant, 46  
    Cleaning, 51  
    Flushing & Refilling, 51  
Replacement Filters, 34

## S

**SAFETY, 10**  
Schematic, Electrical, 56  
Schematic, Hydraulic, 54  
Service, 44  
Specifications, 4  
Starting Engine, 24  
Steering, See Controls  
Storage, 53

## T



Tables  
    Lubricants, 33  
    Paint Notice, 58  
Theft Deterrents, 31  
Torque Specifications, Standard Hardware, 68  
Transporting, 28  
Travel Speed, See Controls  
Troubleshooting, 36



## W

Warranty, Inside Back Cover  
Water Trap, See Fuel Filter

# Torque Specifications









































Use these torque values when tightening GEHL hardware (excluding: Locknuts and Self-tapping, Thread-forming and Metal Screws) unless otherwise specified.

Unified National Thread	Grade 2 		Grade 5 		Grade 8 	
	Dry	Lubed	Dry	Lubed	Dry	Lubed
8-32	19*	14*	30*	22*	41*	31*
8-36	20*	15*	31*	23*	43*	32*
10-24	27*	21*	43*	32*	60*	45*
10-32	31*	23*	49*	36*	68*	51*
1/4-20	66*	50*	9	75*	12	9
1/4-28	76*	56*	10	86*	14	10
5/16-18	11	9	17	13	25	18
5/16-24	12	9	19	14	25	20
3/8-16	20	15	30	23	45	35
3/8-24	23	17	35	25	50	35
7/16-14	32	24	50	35	70	55
7/16-20	36	27	55	40	80	60
1/2-13	35	35	75	55	110	80
1/2-20	40	40	90	65	120	90
9/16-12	55	55	110	80	150	110
9/16-18	60	60	120	90	170	130
5/8-11	75	75	150	110	220	170
5/8-18	85	85	180	130	240	180
3/4-10	130	130	260	200	380	280
3/4-16	150	150	300	220	420	320
7/8-9	125	125	430	320	600	460
7/8-14	140	140	470	360	660	500
1-8	190	190	640	480	900	680
1-14	210	210	710	530	1000	740

Metric Course Thread	Grade 8.8 		Grade 10.9 		Grade 12.9 	
	Dry	Lubed	Dry	Lubed	Dry	Lubed
M6-1	8	6	11	7	13.5	10*
24M8-1.25	19	14	27	20	32.5	24*
M10-1.5	37.5	28	53	39	64	47
M12-1.75	65	48	91.5	67.5	111.5	82
M14-2	103.5	76.5	145.5	108	176.5	131
M16-2	158.5	117.5	223.5	165.5	271	200

\* All torque values are in lb-ft except those marked with an \* which are in lb-in.  
For metric torque value (Nm) multiply lb-ft x 1.355 or lb-in value x 0.113.

# INTERNATIONAL SYMBOLS

					
STARTER	IGNITION ON	ALL POWER OFF	POWER ON ACCESSORIES	WORK LIGHT	EMERGENCY OR HAZARD FLASHER
					
HORN	ENGINE OIL PRESSURE	ENGINE HOURS (Running Time)	AMMETER OR GENERATOR LIGHT	HEATER STARTER	FUSE
					
	Full				
ENGINE COOLANT TEMPERATURE					
	1/2 Full				
					
	CAUTION: PRESSURIZED RADIATOR				
					
					
SPEED RANGE				BUCKET CONTROL	LIFT ARM CONTROL



**THIS OPERATOR'S MANUAL IS  
PROVIDED FOR OPERATOR USE**

**DO NOT REMOVE  
FROM THIS MACHINE**

**THANK YOU**

**DO NOT START, OPERATE OR WORK ON THIS MACHINE UNTIL YOU HAVE CAREFULLY READ AND THOROUGHLY UNDERSTAND THE CONTENTS OF THE OPERATOR'S MANUAL.**

**FAILURE TO FOLLOW SAFETY, OPERATING AND MAINTENANCE INSTRUCTIONS COULD RESULT IN SERIOUS INJURY TO THE OPERATOR OR BYSTANDERS, POOR OPERATION, AND COSTLY BREAKDOWN.**

**IF YOU HAVE ANY QUESTIONS ON PROPER OPERATION, ADJUSTMENT OR MAINTENANCE OF THIS MACHINE, CONTACT YOUR DEALER OR THE SERVICE DEPARTMENT OF GEHL COMPANY BEFORE STARTING OR CONTINUING OPERATION.**

**CALIFORNIA  
Proposition 65 Warning**

Diesel engine exhaust and some of its constituents are known to the state of California to cause cancer, birth defects, and other reproductive harm.

**GEHL**®

**GEHL Company 143 Water Street, P.O. Box 179, West Bend, WI 53095-0179**