

Form No.
909916
Revision B

5205/5305/5380

3-Auger Mixer Feeders



PARTS MANUAL

GEHL® AGRICULTURE

Introduction

When ordering service parts, specify the correct part number, full description, quantity required, the unit model number and serial number.

The Mixer Feeder model and serial number is on a plate located on the left side of the main frame. “Right” and “left” are determined from a position standing behind the Mixer Feeder facing the direction of travel. From this position, the discharge gate is on the “left” side.

GEHL® Company reserves the right to make changes or improvements in the design or construction of any part of the unit without incurring the obligation to install such changes on any previously delivered units.

NOTE: *On original tire replacement, Company policy prohibits the sale of replacement tires for all GEHL machinery. Replacement wheel sets are available and tire size information is called out with the wheel sets to facilitate replacement tire selection. ALL REPLACEMENT TIRES MUST BE PURCHASED LOCALLY.*

Refer to the abbreviations table located on this page for the various fastener descriptions. Standard attaching hardware torque values are also provided on the inside back cover.

In the exploded view parts list, reference numbers may have additional information following the reference number. A tear drop symbol will indicate an application of a “wet” product such as oil, and the number inside the tear drop will correspond to the description in the parts list. Also, a number inside of a hexagon will be the torque value required, in foot pounds, on the associated reference number. Items shown in the parts list that do not have reference numbers are shown for reference purposes only and are NOT available for purchase.

An indent/bullet system of parts listing is used in this book to indicate parts included in an assembly or subassembly. All assembly parts are listed under that assembly and are indented and bulleted. All assembly parts will be included if an assembly or subassembly is ordered.

Unless otherwise specified, all cap screws or bolts are Grade 5, cadmium or zinc plated; hexagon nuts for Grade 5 screws or bolts are Grade B; hexagon nuts for other screws or bolts are Grade A.

NOTE: *The following abbreviations may used herein:*

ASSD	- Assembled
ASSY	- Assembly
CB	- Carriage Bolt
CCW	- Counterclockwise
CP	- Cotter Pin
CS	- Cap Screw (Hexagon Head)
CTR	- Center
CW	- Clockwise
DEG	- Degree
DIA	- Diameter
FCS	- Flanged Cap Screw
FHMS	- Flat Head Machine Screw
FL	- Flanged
FLN	- Flanged Lock Nut (Hexagon)
FLS	- Flanged Lock Screw (Hexagon)
FW	- Flat Washer
GA	- Gauge
GR	- Grade
HD	- Hard or Head
HN	- Hex Nut
INCL	- Includes
JT	- Joint
LG	- Large
LH	- Left Hand
LW	- Lock Washer
LN	- Lock Nut
LW	- Lock Washer
M	- Metric
MM/mm	- Millimeter
NF	- National Fine
PB	- Plow Bolt
PTO	- Power Take Off
RH	- Right Hand
RHMS	- Round Head Machine Screw
RPM	- Revolutions Per Minute
RT	- Right
SERR	- Serrated
SHCS	- Socket Head Cap Screw
SHSS	- Socket Head Set Screw
SN	- Serial Number or Slotted Nut
SQ	- Square
T	- Tooth or Teeth
TFS	- Thread Forming Screw
THMS	- Truss Head Machine Screw
THRD	- Thread
WLDMT	- Weldment
#	- Number
()	- (Quantity Used Here)
	- Torque required in foot pounds
	- Indicates a fluid application

TABLE OF CONTENTS

Introduction	Inside Front Cover
Table of Contents	1
Decal Locations	2-7
Auger, Stub Shafts & Bearings	8-9
Front Drive	10-11
Subframe, Doors & Weighbars	12-13
Trailer Frame, Tires & Wheels	14-15
PTO Shaft	16-17
Auger Discharge Assembly	18-19
Belt Discharge Assembly	20-21
Scales	22-23
Lights	24-25
Bumper, Fender, Flood Light & Side Extensions	26-27
Accessories - Safety Chain	28-31
Hydraulic Height Control	28-29
Pressure Relief Kit	30
Safety Chain	31
Alphabetical Index	32
Numerical Index	33-36
Standard Hardware Torque specifications	Inside Back Cover

DECAL LOCATIONS

GENERAL INFORMATION

Decal location information is provided to assist in the proper selection and application of new decals, in the event the original decals become damaged or the machine is repainted. Refer to the listing for the illustration reference number, part number, description and quantity of each decal provided in the kit. Refer to the appropriate illustrations for replacement locations.

NOTE: Refer to the *SAFETY Chapter of the Operator's Manual for the specific information provided on all of the various safety decals furnished in the decal kit(s).*

To ensure proper selection for correct replacement decals, compare all of the various close-up location illustrations to your machine **BEFORE** starting to refinish the unit. Then, circle each pictured decal (applicable to your machine) while checking off its part number in the listing. After you have verified all the decals needed for replacement, set aside unneeded decals for disposal.

NEW DECAL APPLICATION

Surfaces **MUST** be free from dirt, dust, grease and other foreign material before applying the new decal. To apply a solid-formed decal, remove the smaller portion of the decal backing paper and apply this part of the exposed adhesive backing to the clean surface while maintaining proper position and alignment. Slowly peel off the other portion of the backing paper while applying hand pressure to smooth out the decal surface.



CAUTION

ALWAYS observe safety precautions shown on decals. If decals become damaged, or if the unit is repainted, replace the decals. If repainting, **BE SURE** that **ALL** decals from the kits that apply to your machine are affixed to your unit.

PAINT NOTICE

Use this list to order paint for refinishing:

906315	One Gal. AG Red
906324	One Qt. Light Grey
906316	6 (12 oz. Spray Cans) AG Red
906325	6 (12 oz. Spray Cans) Light Grey

The decal kit numbers for the 5205 is 170860, for the 5305 is 170861, and for the 5380 is 170862. The kits include the following:

Ref. Part

No.	No.	Description & Quantity
1	091438	WARNING - Chain Drive
2	091444	DANGER - Rotating Driveline
3	093367	WARNING - Owner's Responsibility & Read Manual
4	093373	WARNING - General Safety
5	093457	WARNING - Keep Door Closed (2 Places)
6	093466	WARNING - 540 RPM
7	093653	WARNING - Rotating Driveline
8	094914	GEHL
9	120399	DANGER - Rotating Auger (4 Places)
10	122617	GEHL (2 Places)
11	122736	GEHL
12	143007	DANGER - Shield Missing
13	145216	Red Reflector (3 Places)
14	145217	Amber Reflector (5 Places)
15	145218	Orange Reflector Strip
16	145234	SMV Marker
17	163941	WARNING - Mandatory Safety Shutdown
18	163962	DANGER - Keep Hands Out (2 Places)
19	163969	WARNING - Hydraulic Oil & Unplugging
20	170783	No Lift (2 Places)
21	170784	Do Not Pressure Wash
22	170785	No Step (3 Places)
23	170854	5205 (2 Places)
	170855	5305 (2 Places)
	170640	5380 (2 Places)

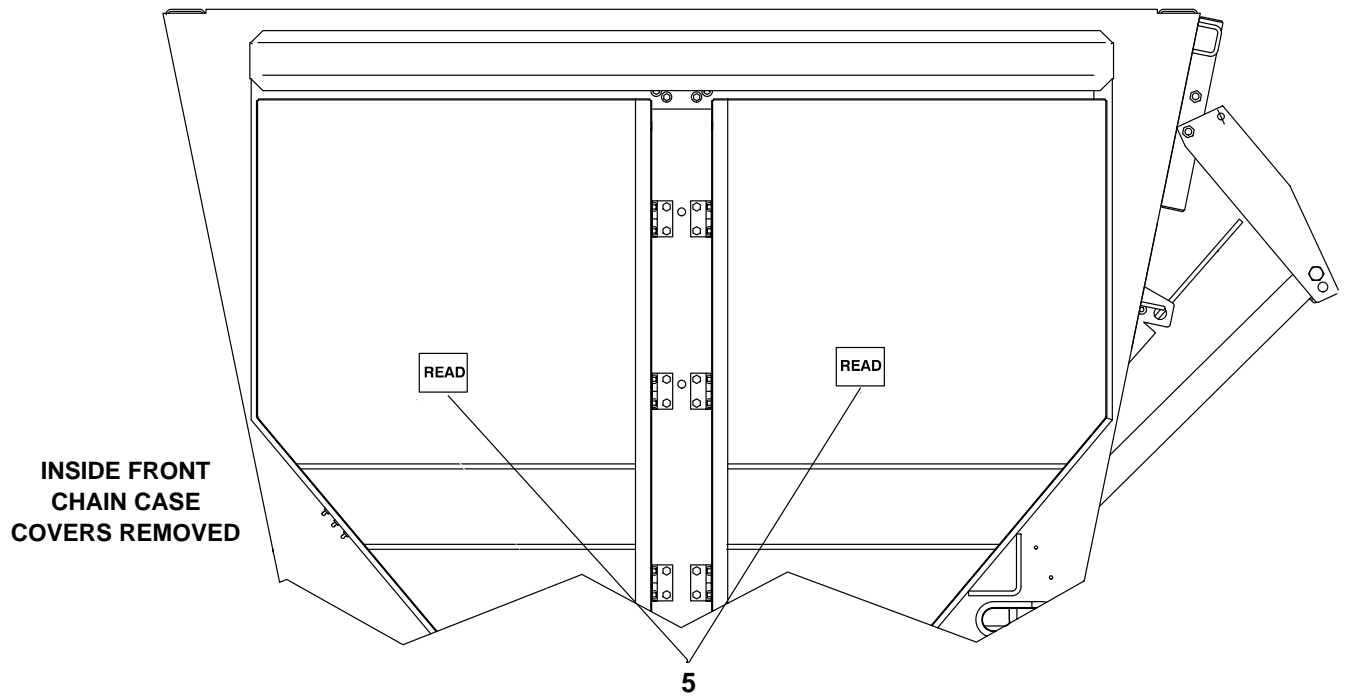
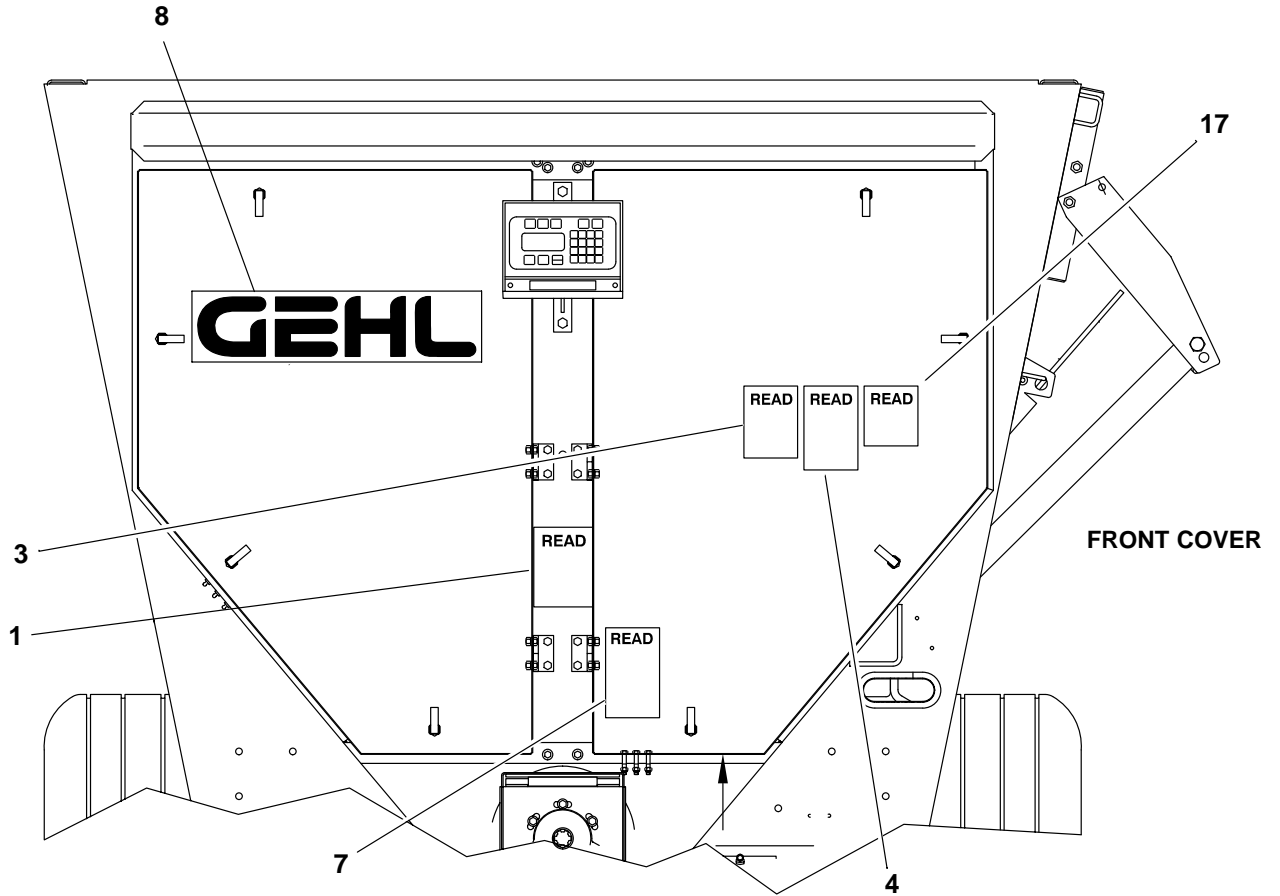

NOTE: *This list is a repeat of the decal list on a previous page and is provided for your convenience when selecting replacement decals.*

Ref. Part

No. No. Description & Quantity

1	091438	WARNING - Chain Drive	10	122617	GEHL (2 Places)
2	091444	DANGER - Rotating Driveline	11	122736	GEHL
3	093367	WARNING - Owner's Responsibility & Read Manual	12	143007	DANGER - Shield Missing
4	093373	WARNING - General Safety	13	145216	Red Reflector (3 Places)
5	093457	WARNING - Keep Door Closed (2 Places)	14	145217	Amber Reflector (5 Places)
6	093466	WARNING - 540 RPM	15	145218	Orange Reflector Strip
7	093653	WARNING - Rotating Driveline	16	145234	SMV Marker
8	094914	GEHL	17	163941	WARNING - Mandatory Safety Shutdown
9	120399	DANGER - Rotating Auger (4 Places)	18	163962	DANGER - Keep Hands Out (2 Places)
			19	163969	WARNING - Hydraulic Oil & Unplugging
			20	170783	No Lift (2 Places)
			21	170784	Do Not Pressure Wash
			22	170785	No Step (3 Places)
			23	170854	5205 (2 Places)
				170855	5305 (2 Places)
				170640	5380 (2 Places)

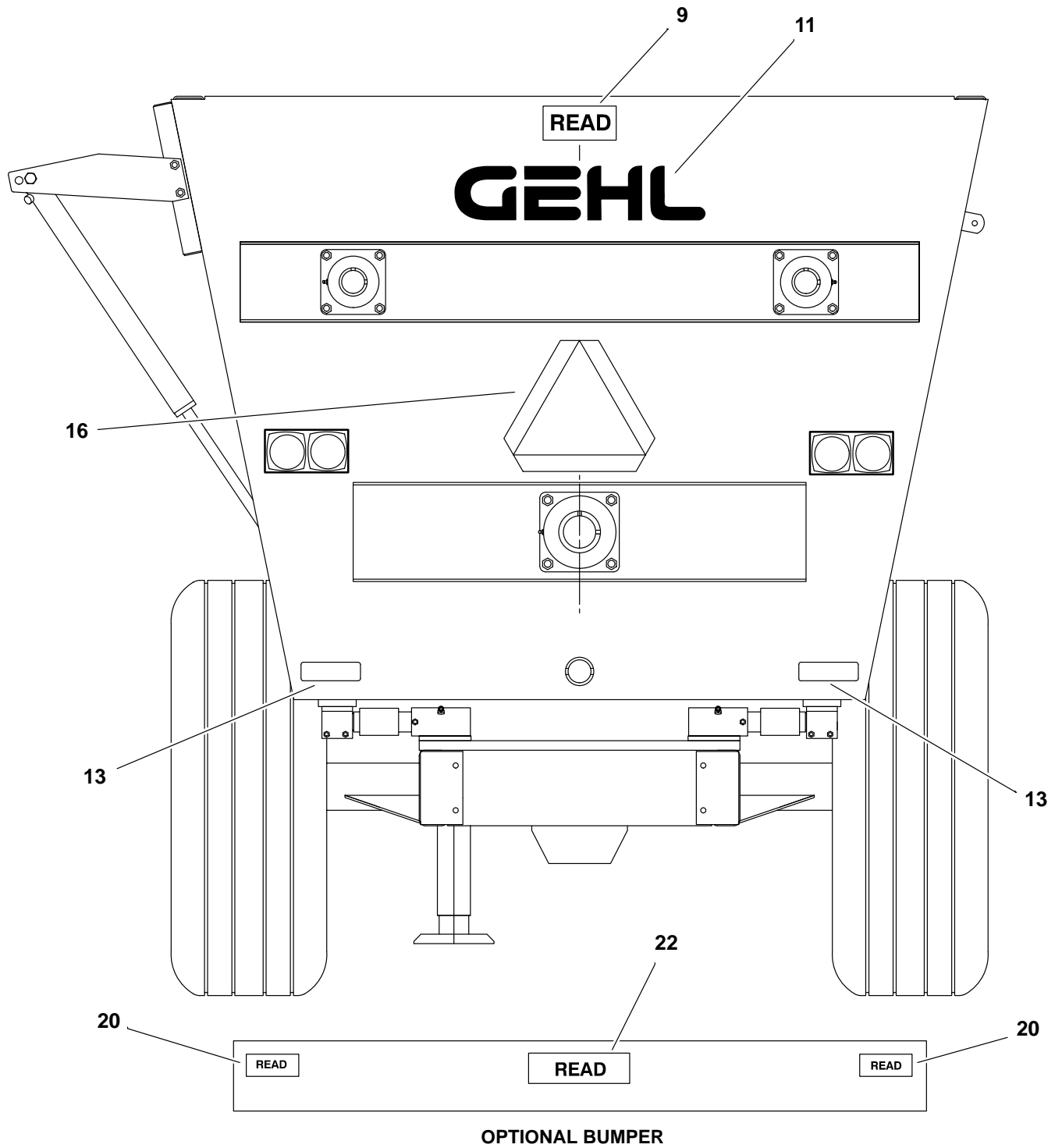

NOTE: This list is a repeat of the decal list on a previous page and is provided for your convenience when selecting replacement decals.

Ref. Part

No. No. Description & Quantity

1	091438	WARNING - Chain Drive	10	122617	GEHL (2 Places)
2	091444	DANGER - Rotating Driveline	11	122736	GEHL
3	093367	WARNING - Owner's Responsibility & Read Manual	12	143007	DANGER - Shield Missing
4	093373	WARNING - General Safety	13	145216	Red Reflector (3 Places)
5	093457	WARNING - Keep Door Closed (2 Places)	14	145217	Amber Reflector (5 Places)
6	093466	WARNING - 540 RPM	15	145218	Orange Reflector Strip
7	093653	WARNING - Rotating Driveline	16	145234	SMV Marker
8	094914	GEHL	17	163941	WARNING - Mandatory Safety Shutdown
9	120399	DANGER - Rotating Auger (4 Places)	18	163962	DANGER - Keep Hands Out (2 Places)
			19	163969	WARNING - Hydraulic Oil & Unplugging
			20	170783	No Lift (2 Places)
			21	170784	Do Not Pressure Wash
			22	170785	No Step (3 Places)
			23	170854	5205 (2 Places)
				170855	5305 (2 Places)
				170640	5380 (2 Places)

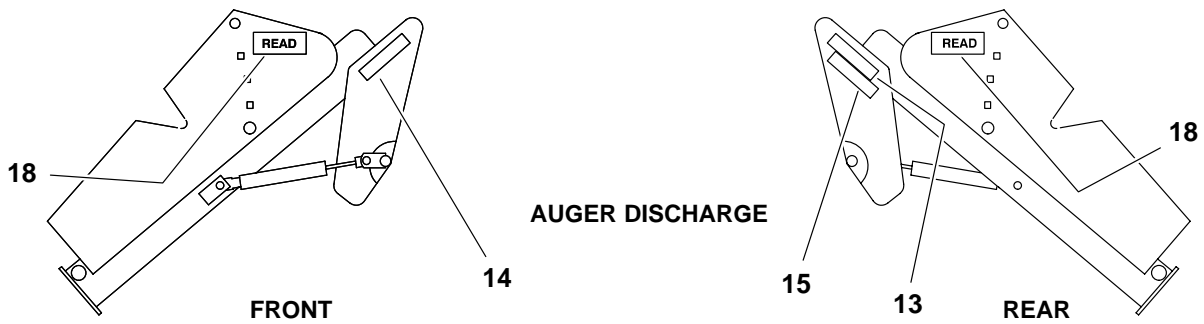

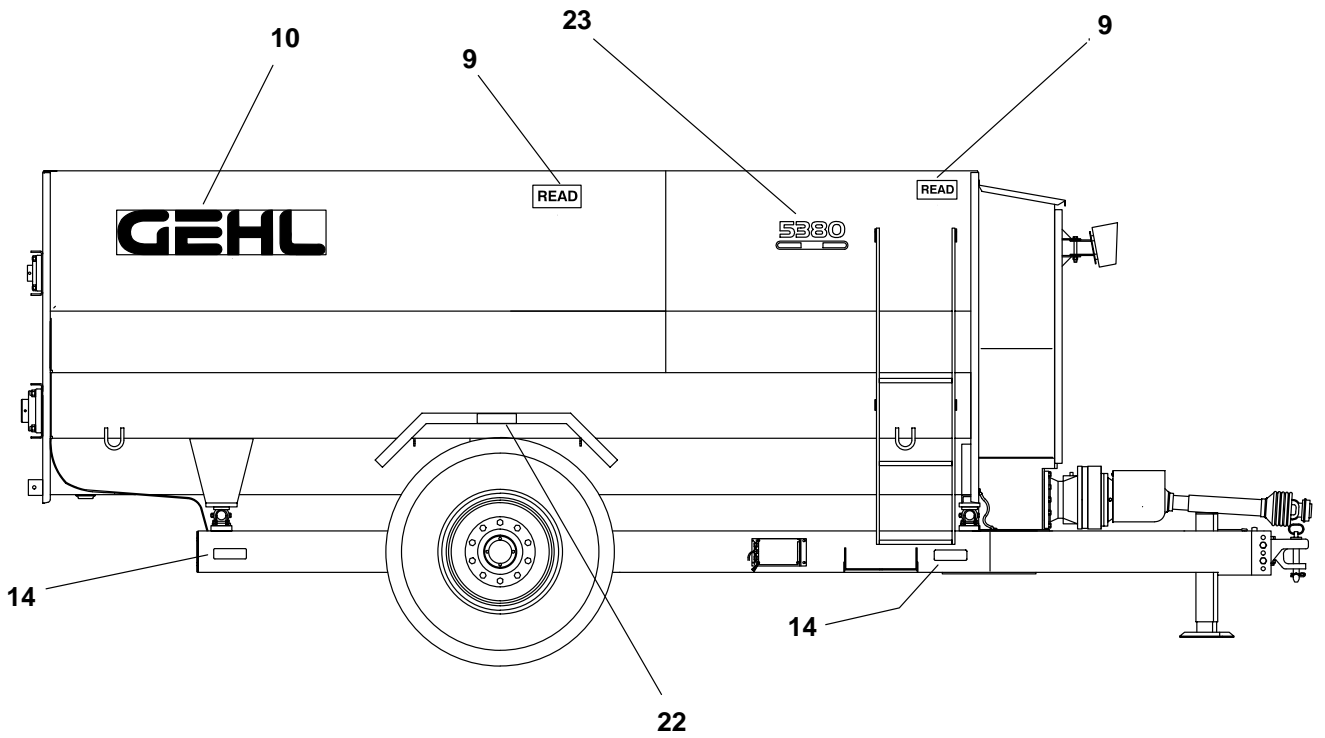
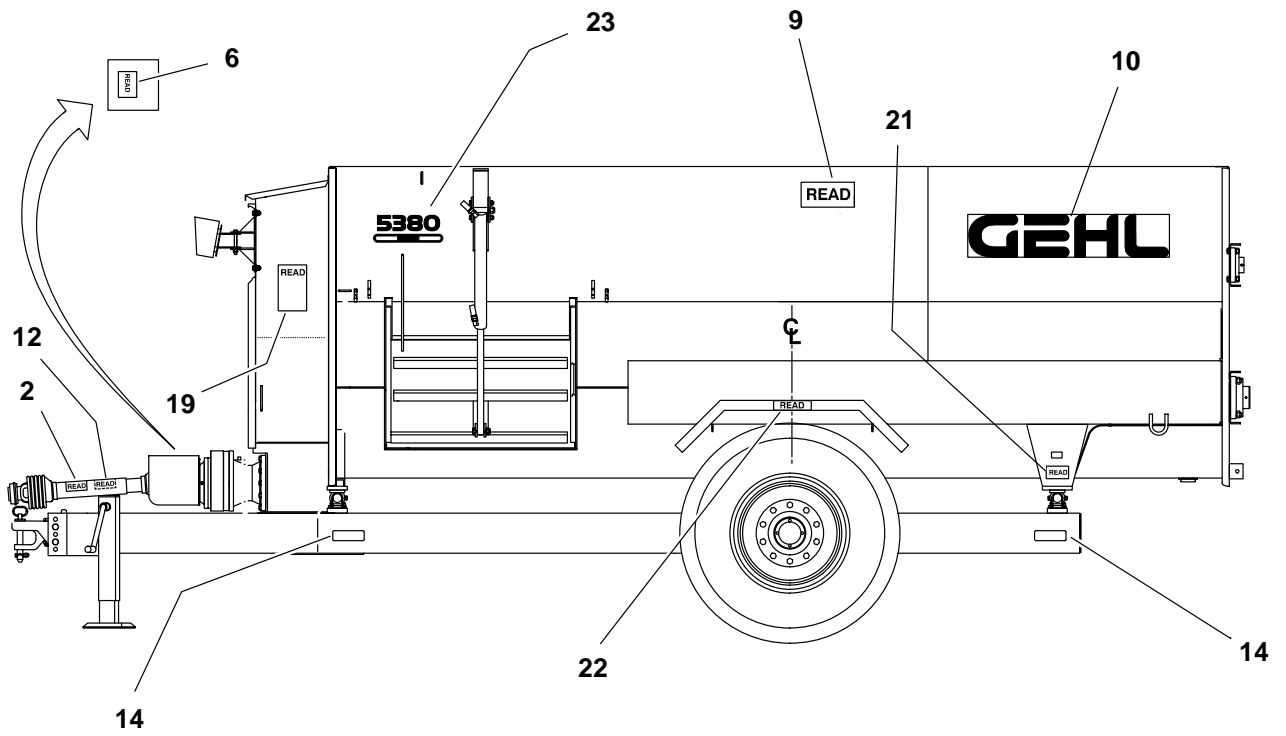

5205/5305/5380 - AUGER, STUB SHAFTS AND BEARINGS

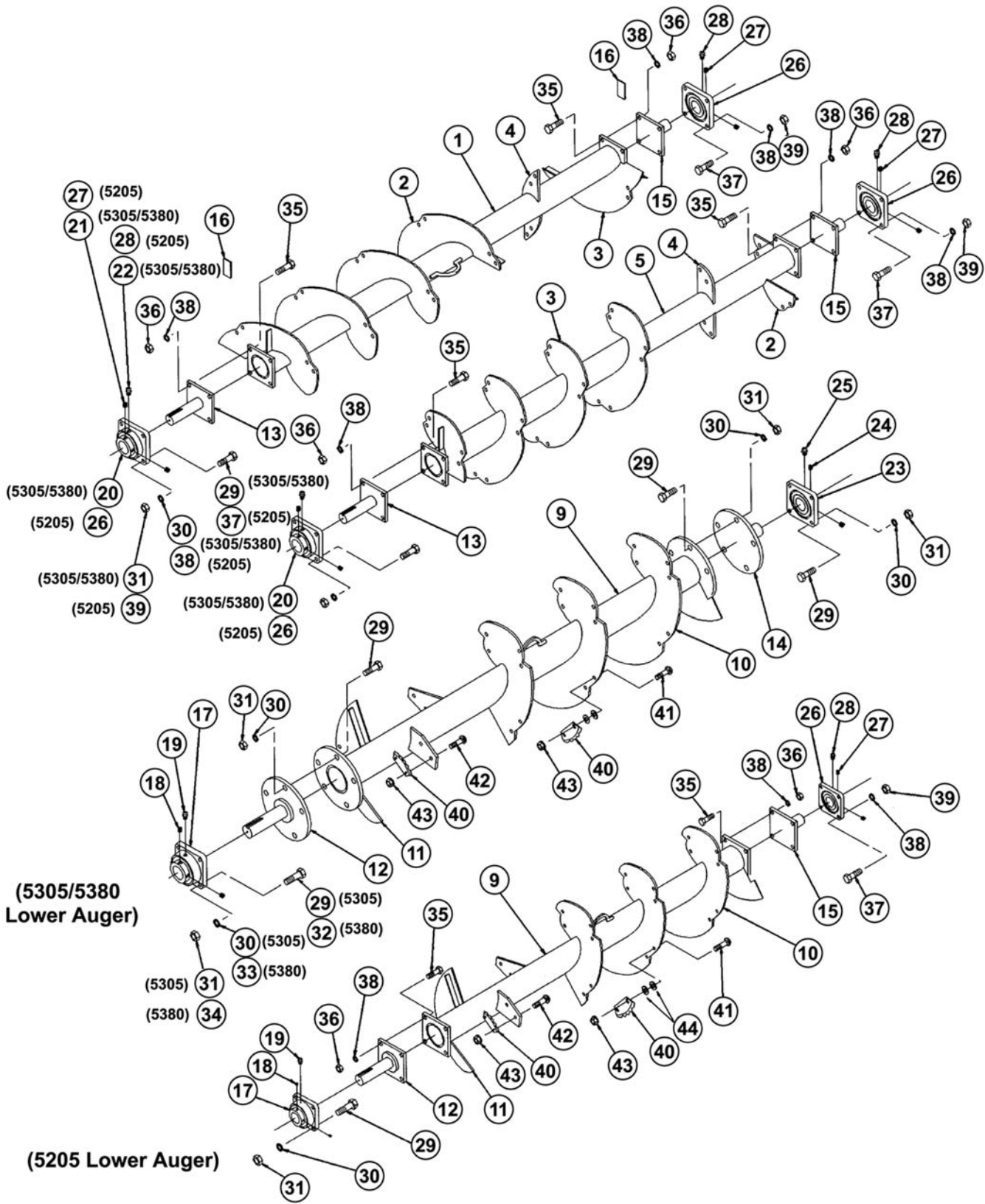

5205/5305/5380 - AUGER, STUB SHAFTS AND BEARINGS

Ref. No.	Part No.	Description	Qty. Req.	Ref. No.	Part No.	Description	Qty. Req.
1	167348	Upper Right Auger (5205)	AR	19	570002	•Grease Fitting 1/8-27NPT	1
2	167374	•Notched Fltg. R.H. 3/8 x 5-9/16 x 20 . . .	4				
3	167375	•Notched Fltg. L.H. 3/8 x 5-9/16 x 20 . . .	1	17	167453	Bearing Sph. 4-Bolt 3-7/16 (5305)	1
4	167308	•Top Shark Fin Kicker	2	18	651592	•SHSS 1/2 x 3/4	2
				19	570002	•Grease Fitting 1/8-27NPT	1
1	167351	Upper Right Auger (5305)	AR				
2	167377	•Notched Fltg. R.H. 3/8 x 5-9/16 x 24 . . .	4	17	167447	Bearing Sph. 4-Bolt 3-15/16 (5380)	1
3	167378	•Notched Fltg. L.H. 3/8 x 5-9/16 x 24 . . .	1	18	651593	•SHSS 5/8 x 1	2
4	167442	•Top Shark Fin Kicker	2	19	570002	•Grease Fitting 1/8-27NPT	1
1	167354	Upper Right Auger (5380)	AR	20	167072	Bearing Fl. 4 Hole 2-15/16 (5305/5380) . . .	2
2	167377	•Notched Fltg. R.H. 3/8 x 5-9/16 x 24 . . .	5	21	651616	•SHSS 7/16 x 1/2 (5305/5380)	2
3	167378	•Notched Fltg. L.H. 3/8 x 5-9/16 x 24 . . .	1	22	570002	•Grease Fitting 1/8-27NPT	1
4	167442	•Top Shark Fin Kicker	2				
				23	167130	Bearing Fl. 4 Hole 3-7/16 (5305/5380) . . .	1
5	167349	Upper Left Auger (5205)	AR	24	651608	•SHSS 1/2 x 1/2 Lg	2
2	167374	•Notched Fltg. R.H. 3/8 x 5-9/16 x 20 . . .	1	25	570002	•Grease Fitting 1/8-27NPT Str	1
3	167375	•Notched Fltg. L.H. 3/8 x 5-9/16 x 20 . . .	4				
4	167308	•Top Shark Fin Kicker	2	26	167395	Bearing Fl. 4 Hole 2-7/16 (5205)	5
						Bearing Fl. 4 Hole 2-7/16 (5305/5380) . . .	2
5	167352	Upper Left Auger (5305)	AR	27	651615	•SHSS 3/8 x 5/16	2
2	167377	•Notched Fltg. R.H. 3/8 x 5-9/16 x 24 . . .	1	28	570002	•Grease Fitting 1/8-27NPT Str	1
3	167378	•Notched Fltg. L.H. 3/8 x 5-9/16 x 24 . . .	4				
4	167442	•Top Shark Fin Kicker	2				
						(5205)	
5	167355	Upper Left Auger (5380)	AR	29	650416	CS 3/4x2-1/2 C5ZY	4
2	167377	•Notched Fltg. R.H. 3/8 x 5-9/16 x 24 . . .	1	30	654034	LW 3/4	4
3	167378	•Notched Fltg. L.H. 3/8 x 5-9/16 x 24 . . .	4	31	653026	HN 3/4	4
4	167442	•Top Shark Fin Kicker	2	35	651127	CS 5/8 x 2-1/2	24
				36	166990	HN 5/8	24
				37	650647	CS 5/8 x 2	20
9	167347	Lower Auger (5205)	AR	38	654032	LW 5/8	44
10	167683	•Notched Fltg. L.H. 1/2 x 8-5/8 x 24 . . .	4	39	653021	HN 5/8	20
11	167376	•Notched Fltg. R.H. 1/2 x 8-5/8 x 24 . . .	1				
						(5305/5380)	
9	167350	Lower Auger (5305)	AR	29	650416	CS 3/4x2-1/2 C5ZY (5305)	26
10	167380	•Notched Fltg. L.H. 1/2 x 8-5/8 x 30 . . .	3			CS 3/4 x 2-1/2 (5380)	22
11	167379	•Notched Fltg. R.H. 1/2 x 8-5/8 x 30 . . .	1	30	654034	LW 3/4 (5305)	26
						LW 3/4 (5380)	22
9	167353	Lower Auger (5380)	AR	31	653026	HN 3/4 (5305)	26
10	167380	•Notched Fltg. L.H. 1/2 x 8-5/8 x 30 . . .	4			HN 3/4 (5380)	22
11	167379	•Notched Fltg. R.H. 1/2 x 8-5/8 x 30 . . .	1	32	167010	CS 7/8 x 3 (5380)	4
				33	650652	LW 7/8 (5380)	4
12		Lower Drive Stub Shaft		34	650655	HN 7/8 (5380)	4
	167169	2-15/16" Dia. (5205)	1	35	651127	CS 5/8 x 2-1/2	16
	167153	3-7/16" Dia. (5305)	1	36	166990	HN 5/8	16
	167196	3-15/16" Dia. (5380)	1	37	650647	CS 5/8 x 2	8
13		Upper Drive Stub Shaft		38	654032	LW 5/8	24
	167170	(5205)	2	39	653021	HN 5/8	8
	167169	(5305/5380)	2				
14	167158	Idler Stub Shaft 3-7/16	1		167654	M-4000 Knife Kit	AR
15	167040	Idler Stub Shaft (5205)	3	40	167333	•M-4000 Knife	25
		Idler Stub Shaft (5305/5380)	2	41	651028	•CB 7/16 x 1-1/4	45
16	167652	Auger Shim	AR	42	651045	•CB 7/16 x 1-3/4	5
17	167448	Bearing Fl. 4 Hole 2-15/16 (5205)	1	43	167133	•HN 7/16	50
18	651597	•SHSS 3/8 x 3/8	2	44	654006	•FW 3/8 AWZY	15

5205/5305/5380 - FRONT DRIVE

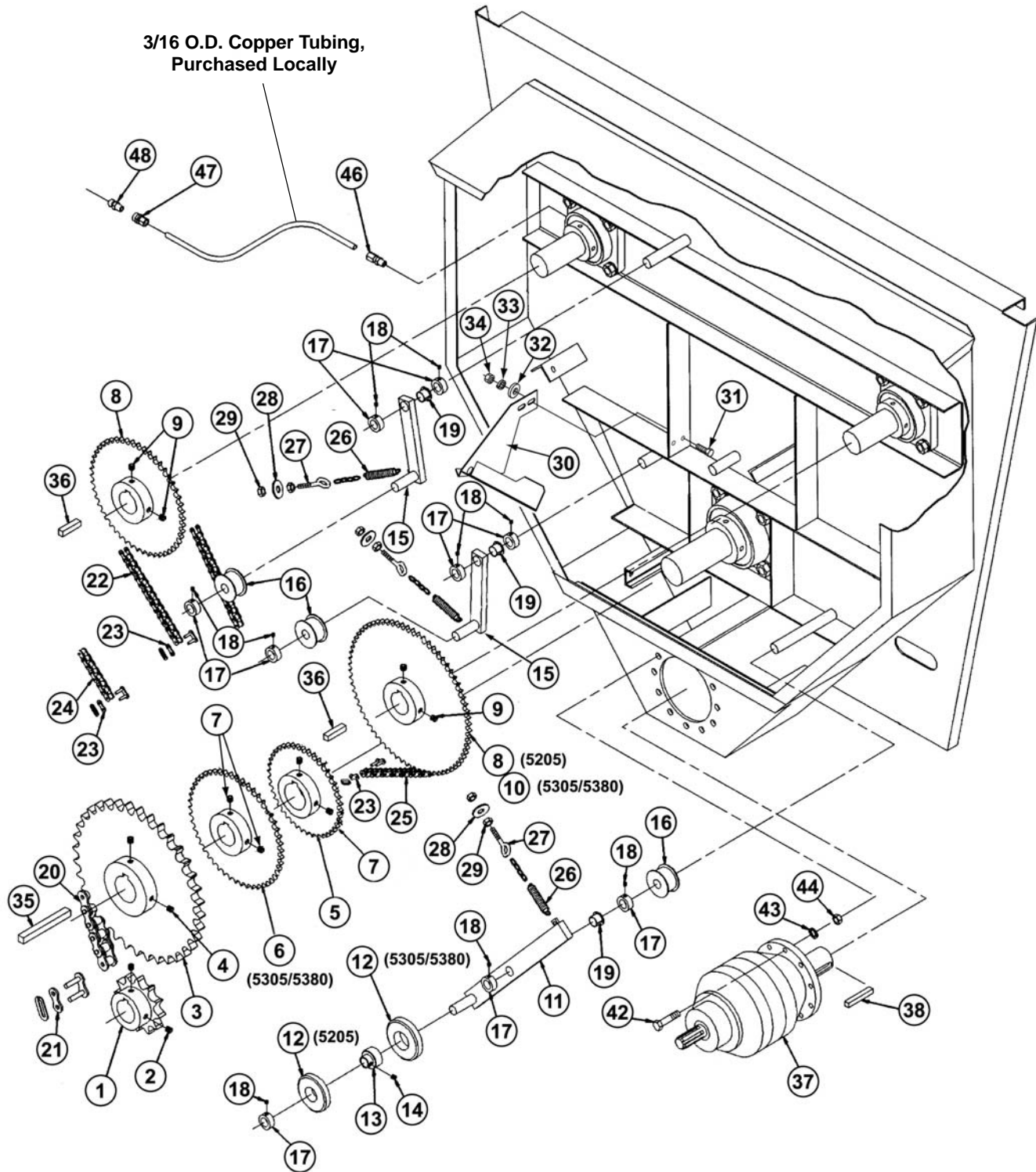

5205/5305/5380 - FRONT DRIVE

Ref. No.	Part No.	Description	Qty. Req.	Ref. No.	Part No.	Description	Qty. Req.
1	167449	Sprocket 120B12 - 2-1/2" (5205)	1	23	500160	•#60 Connector Link	1
	167450	Sprocket 140B12 - 3" (5305/5380)	1				
2	651591	•SHSS 5/8 x 5/8	2	20	167435	Roller Chain #140 x 46 Links (5305/5380)	1
3	167386	Sprocket 120B36 - 2-15/16" (5205)	1				
		Sprocket 140B36		21	601237	•#140 Connector Link	1
	167334	3-7/16 Bore 7/8" Keyway (5305)	1	22	167672	Roller Chain #80 x 122 Links (5305/5380)	1
	167335	3-15/16" Bore (5380)	1				
4	651591	•SHSS 5/8 x 5/8	2	23	500195	•#80 Connector Link	1
	651582	•SHSS 5/8 x 3/4" (5305/5380)	2	24	167230	Roller Chain #80 x 8 Rollers (Opt.) (5305/5380)	AR
5	167216	Sprocket 60B42 - 2-15/16" (5205)	2				
		Sprocket 80B33		23	655020	•#80 Connector Link	1
	167305	3-7/16 Bore 7/8" Keyway (5305)	1	25	167019	Roller Chain #80 x 218 Links (5205)	1
	167451	3-15/16 Bore (5380)	1	23	500160	•#60 Connector Link	1
7	651591	•SHSS 5/8 x 5/8	2	25	167015	Roller Chain #80 x 176 Links (5305/5380)	1
6		Sprocket 80B50		23	500195	•#80 Connector Link	1
	167685	3-7/16 Bore 7/8" Keyway (5305)	1	26	166980	Extension Spring	3
	167684	3-15/16 Bore (5380)	1	27	167455	Eyebolt 3/8 x 6	3
7	651591	•SHSS 5/8 x 5/8	2	28	654006	FW 3/8	3
8	167388	Sprocket 60B70 - 2-7/16 Bore (5205)	2	29	653010	HN 3/8	6
		Sprocket (Upper Right) (5305/5380)		30	167686	Oiler Weldment (5205-5380)	1
	167390	80B50 x 2-15/16 B. (Standard)	1	31	650487	•CS 5/16 x 1	2
	167385	80B65 x 2-15/16 B. (Optional)	AR	32	654004	•FW 5/16	2
9	651591	•SHSS 5/8 x 5/8	2	33	654024	•Washer, 5/16 Med. Split	2
10		Sprocket (Upper Left) (5305/5380)		34	653007	•HN 5/16	2
	167385	80B65 x 2-15/16 B.	1	35	167436	Key, 3/4 Sq. x 6" (5205)	1
9	651591	•SHSS 5/8 x 5/8	2		167434	Key, 7/8 Sq. x 8" (5305)	1
11	167047	Tensioner Arm 17" (5205)	1		167275	Key, 1 Sq. x 8" (5380)	1
	167048	Tensioner Arm 23-7/8" (5305/5380)	1	36	167676	Key, 5/8 Sq. x 3-3/4" (5205)	2
12		Idler			167436	Key, 3/4 Sq. x 6" (5305/380)	2
	167066	#120 x 1" Bore (5205)	1				
	167001	4.5 O.D. x 7/8 x 1" B (5305/5380)	1	37	167705	Planetary Reducer 10.8:1 (5205)	AR
13	167048	•Bearing Ball 1" B. x 2.0472 O.D. (5305/5380)	1		167704	Planetary Reducer 12.2:1 (5305/5380)	AR
14	651595	••SHSS 1/4 x 1/4 (5305/5380)	2	38	167009	•Key, 5/8 Sq. x 2-3/4" (5205)	1
15	167671	Idler Arm	2		167024	•Key, 3/4 Sq. x 4-1/4" (5305/5380)	1
16	167229	#80 Idler Wheel, 1" B.	3	42	650585	CS 1/2 x 2 (5205)	10
17	S16174	Collar/Set	9		650424	CS 9/16x2 F5ZY (5305/5380)	12
18	650200	•SHSS 5/16 x 1/4	1	43	654056	LW 9/16	12
19	167242	Bearing Sleeve 1" B. Plastic	3	44	068034	HLN-Ins 1/2 (5205)	10
					651587	HN 9/16 (5305/5380)	12
20	167017	Roller Chain #120 x 46 Links (5205)	1	46	580069	Male Connector 1/8NPT x 3/16	3
21	601032	•#120 Connector Link	1	47	167002	Female Connector 1/8NPT x 3/16	3
22	167018	Roller Chain #60 x 148 Links (5205)	1	48	570002	Grease Fitting, Str. 1/8NPT	3

5205/5305/5380 - SUBFRAME & DOORS

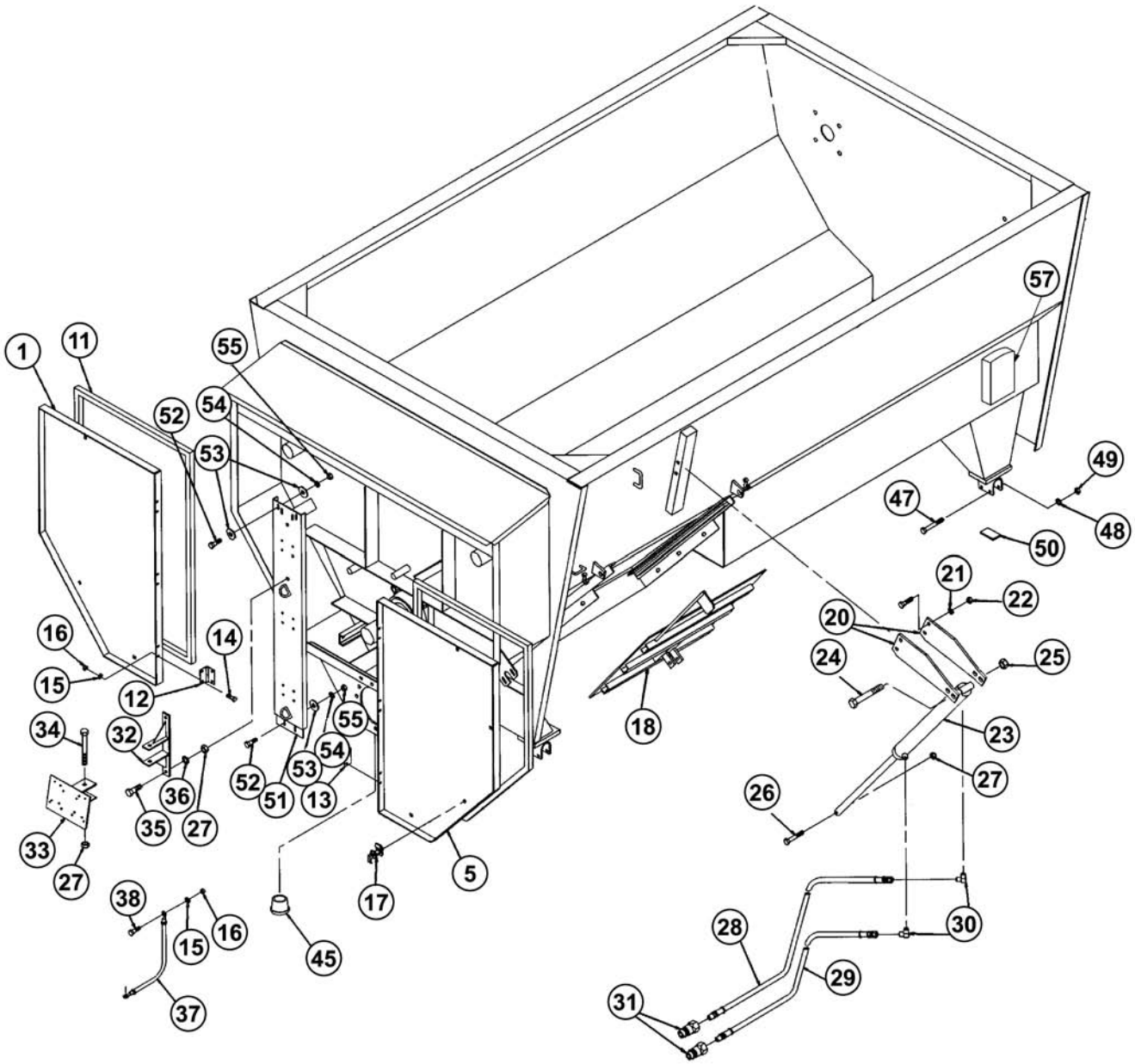

5205/5305/5380 - SUBFRAME & DOORS

Ref. No.	Part No.	Description	Qty. Req.	Ref. No.	Part No.	Description	Qty. Req.
1	167695	R.H. Door (5205)	1	30	114824	90° Elbow 3/4-16 x 9/16-18 ORB	2
	167693	R.H. Door (5305/5380)	1	31	154615	Male Tip 3/4-16 O-Ring Boss	2
5	167696	L.H. Door (5205)	1	32	167269	Indicator Bracket	1
	167694	L.H. Door (5305/5380)	1	33	167270	Indicator Plate Assy	1
11	167215	Foam Strip 25'	1	34	650653	CS 1/2 x 4-1/2	1
12	167397	R.H. Hinge	3	35	650495	CS 1/2 x 1-1/4	2
13	167398	L.H. Hinge	3	36	654009	FW 1/2	2
14	650542	CS 1/4 x 1/2	24	37	167691	Ground Wire - 12"	1
15	654022	LW 1/4	26	38	650663	CS 1/4 x 5/8	2
16	653005	HN 1/4	26	45	167394	2" PVC Pipe Plug	2
17	167396	Door Latch	8	47	650818	CS 3/8 x 3	8
18	167858	Discharge Door	1	48	654026	LW 3/8	8
20	167046	Cylinder Mount Extension	2	49	653010	HN 3/8	8
21	654030	LW 1/2	2	50	166988	Mount	4
22	653018	HN 1/2	2	51	167244	Center Brace (5205)	1
23	167065	Hyd. Cylinder 24-3/4" Stroke	1		167245	Center Brace (5305/5380)	1
24	650849	CS 3/4 x 5	1	52	650487	CS 5/16 x 1	6
25	079209	HLN-Ins 3/4	1	53	654004	FW 5/16	10
26	650644	CS 1/2 x 3	1	54	654024	LW 5/16	6
27	068034	HLN-Ins 1/2	4	55	653007	HN 5/16	6
28	167035	3/8 Hyd. Hose w/Ends x 185" Lg.	1	57	167677	Plastic Manual Pack	1
29	167034	3/8 Hyd. Hose w/Ends x 211" Lg.	1				

5205/5305/5380 - TRAILER FRAME, TIRES & WHEELS & WEIGHBARS _____

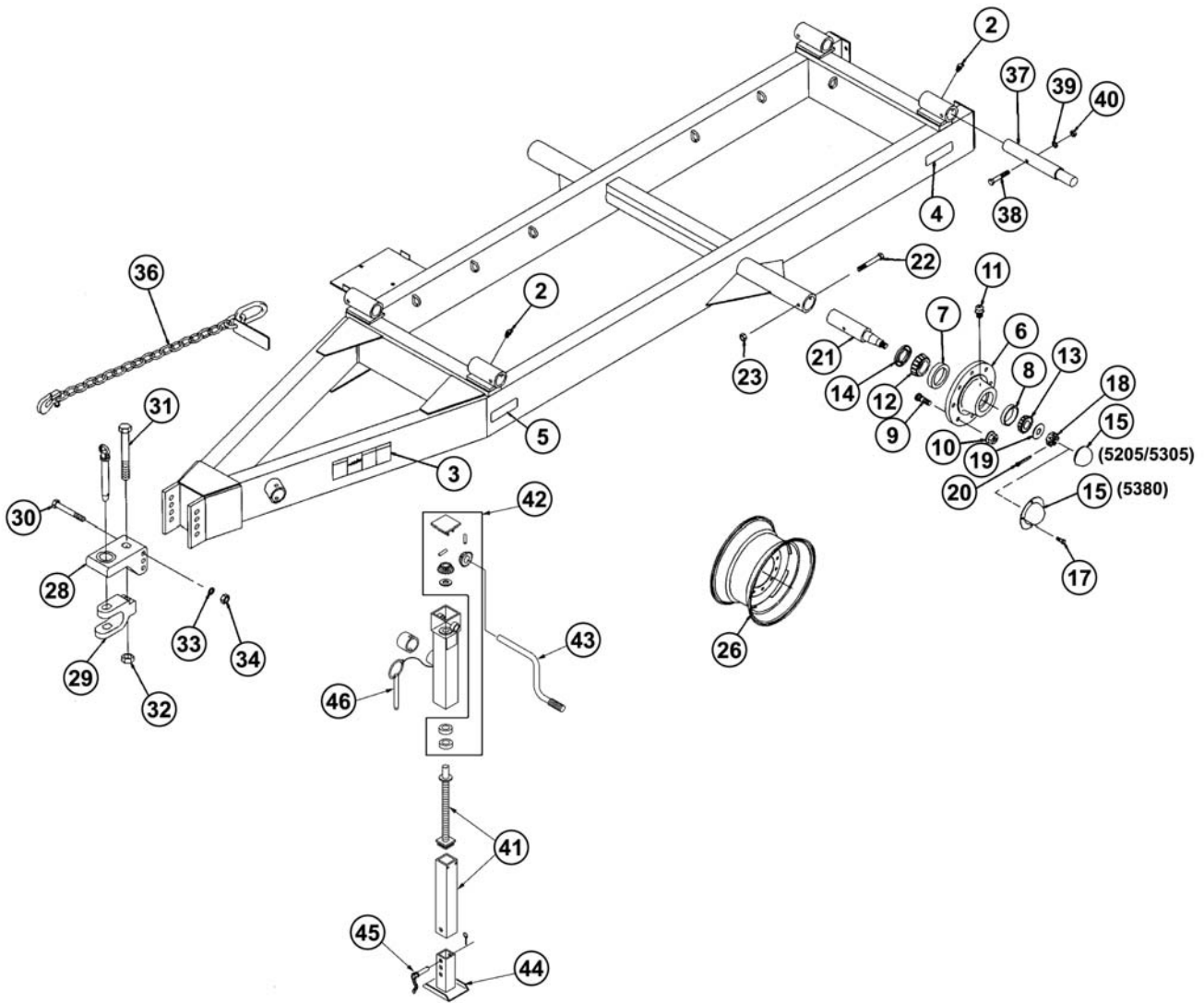

5205/5305/5380 - TRAILER FRAME, TIRES & WHEELS & WEIGHBARS

Ref. No.	Part No.	Description	Qty. Req.	Ref. No.	Part No.	Description	Qty. Req.
2	570009	•Grease Fitting 1/4-28NF x 45°	4	22	650653	CS 1/2 x 4-1/2 (5205/5305)	2
	167787	Hub and Spindle Assy (5205/5305)	2		650846	CS 5/8 x 6 (5380)	2
6	167808	•Hub w/Studs, Cups and Nuts	1	23	071706	LN 1/2 (5205/5305)	2
7	042162	••Bearing Cup, Inner	1		071709	LN 5/8 (5380)	2
8	004375	••Bearing Cup, Outer	1				
9	078657	••Wheel Bolt 5/8 x 2-1/4	8	26	112444	•Wheel, W8B-20	1
10	604330	••Wheel Nut 5/8	8		167293	•Wheel for 40 x 14 Aircraft Tire	1
11	570002	••Grease Fitting 1/8-27NPT Str.	1				
12	003940	•Bearing Cone, Inner	1				
13	042163	•Bearing Cone, Outer	1	26	141268	•Wheel, 13.00 x 22.5-10 Bolt w/o Offset	1
14	167227	•Grease Seal 3/8 x 2-3/4 O.D.	1		167294	•Wheel for 44 x 16 Aircraft Tire	1
15	003938	•Grease Cap, 3-1/8	1				
18	650933	•HN 1	1	28	167239	Base Hitch	1
19	003943	•Washer	1	29	167251	Clevis	1
20	655022	•CP 3/16 x 1-3/4	1	30	650526	CS 3/4 x 6	2
21	167050	•Spindle, 2-3/4	1	31	651594	CS 3/4 x 5	1
	167822	Hub and Spindle Assembly (5380)	2	32	167281	LN Top 3/4	1
6	167853	•Hub w/Studs, Cups and Nuts	1	33	654034	LW 3/4	2
7	078943	••Bearing Cup, Inner	1	34	653026	HN 3/4	2
8	120433	••Bearing Cup, Outer	1	36	142967	Ag Safety Chain	1
9	120403	••Wheel Bolt, 3/4-16NF	10	37	167641	Connecting Bars (Set of 4)	1
10	167057	••Wheel Nut 3/4-16NF	10	38	650731	CS 3/8 x 3-1/2	4
12	167021	••Bearing Cone, Inner	1	39	654026	LW 3/8	4
13	120434	••Bearing Cone, Outer	1	40	653010	HN 3/8	4
14	078947	••Seal 3 x 4-1/2 x 7/16"	1		167687	Sidewind Jack - 8,000 Lb.	1
15	120617	••Dust Cap	1	41	167679	•Inner Tube/Screw & Nut Assembly, SW	1
17	650484	••CS 5/16 x 1/2	4				
18	651381	•HN SLTD 1-1/4 F2	1	42	170771	•Final Assembly Kit	1
19	167081	•Washer	1	43	170772	•Crank Assembly	1
20	655030	•CP 1/4 x 2	1	44	167682	•Drop Leg and Base (Plate)	1
21	167373	•Spindle, 3-3/4	1	45	167681	•Pull Pin Assembly 3/4" x 2.75	1
				46	167680	•Pull Pin Assembly 3/4" x 4.75	1

5205/5305/5380 - PTO SHAFT

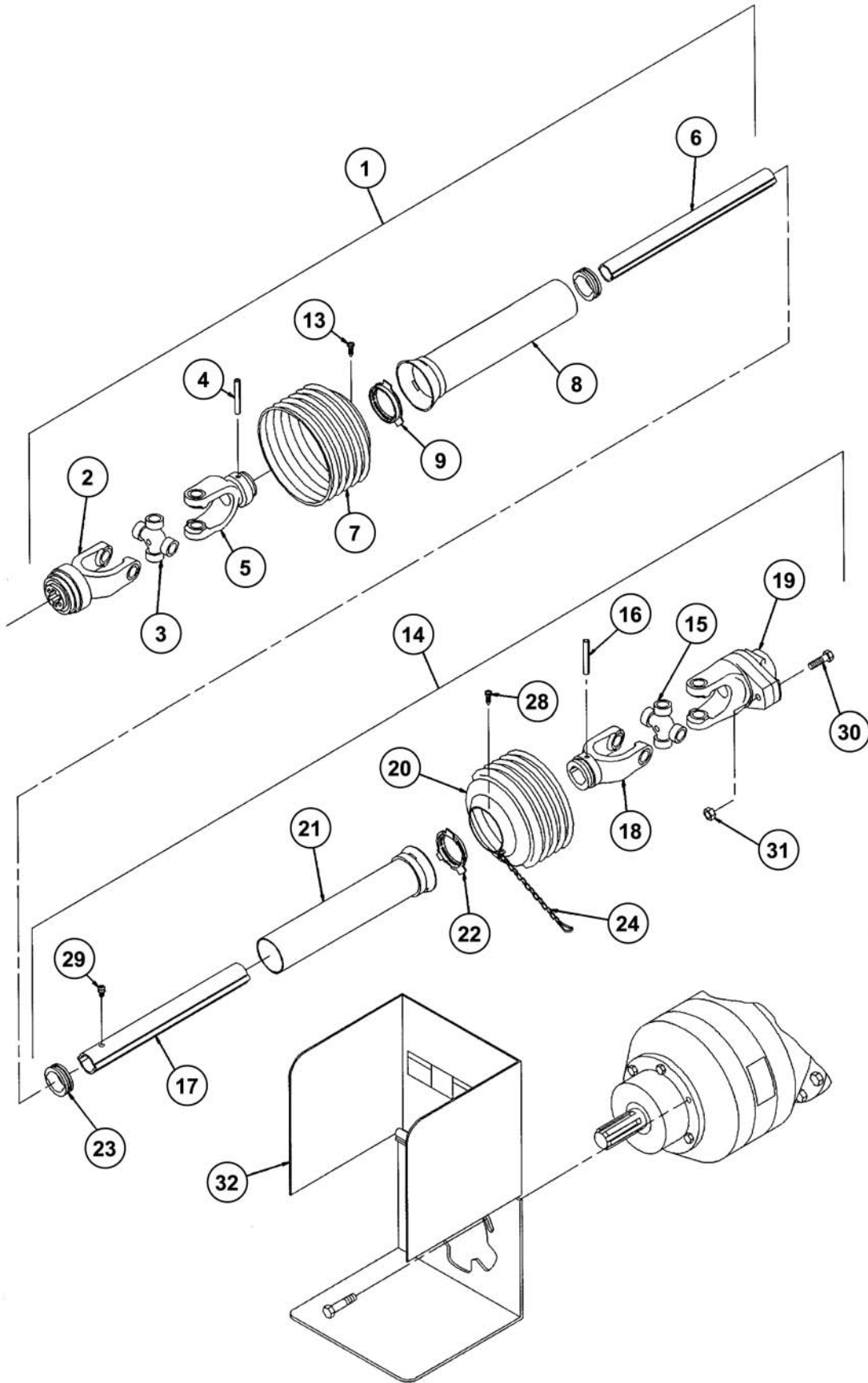

5205/5305/5380 - PTO SHAFT

Ref. No.	Part No.	Description	Qty. Req.	Ref. No.	Part No.	Description	Qty. Req.
	167324	540 PTO Shaft w/Clutch	1	20	167110	••Shield Cone 5 Rib	1
1	167327	•540 Tractor Half Shaft	1	21	167300	••Inn. Shield Tube Rnd	1
2	613982	••Yoke, 1-3/8 - 6 Spl. ASGE	1	22	604725	••Bearing Ring SC25	1
3	086910	••Cross Bearing Kit	1	23	086943	••Support Bearing	1
4	167102	••Spring Pin, 10 x 75	1	24	604728	••Safety Chain	1
5	167113	••Inboard Yoke 1b	1	28	086921	••Screw	1
6	167271	••Inner Profile 1b x 640	1	29	086922	••Grease Zerk	1
7	167110	••Shield Cone 5 Rib	1				
8	167299	••Out. Shield Tube Ovl	1		167868	M6 Shear Bolt Bag (5205)	AR
9	604725	••Bearing Ring SC25	1	30		•Bolt, Hex. Hd. M6 x 45mm CL8.8 Full Thread	5
13	086921	••Screw	1	31		•Nut, Hex. M6 x 1.0 Nylon Lk.	5
14	167326	•Implement Half Shaft	1				
15	086910	••Cross Bearing Kit	1		167867	M6 Shear Bolt Bag (5305/5380)	AR
16	167102	••Spring Pin, 10 x 75	1	30		•Bolt, Hex. Hd. M6 x 45mm CL8.8	5
17	167286	••Profile Sleeve W.A	1	31		•Nut, Hex. M6 x 1.0 Nylon Lk.	5
18	167105	••Inboard Yoke 2a	1				
19	167297	••Shearbolt, Clutch 1-3/8 - 6 Spl	1	32	167702	PTO Guard Assembly	1

5205/5305/5380 - BELT DISCHARGE

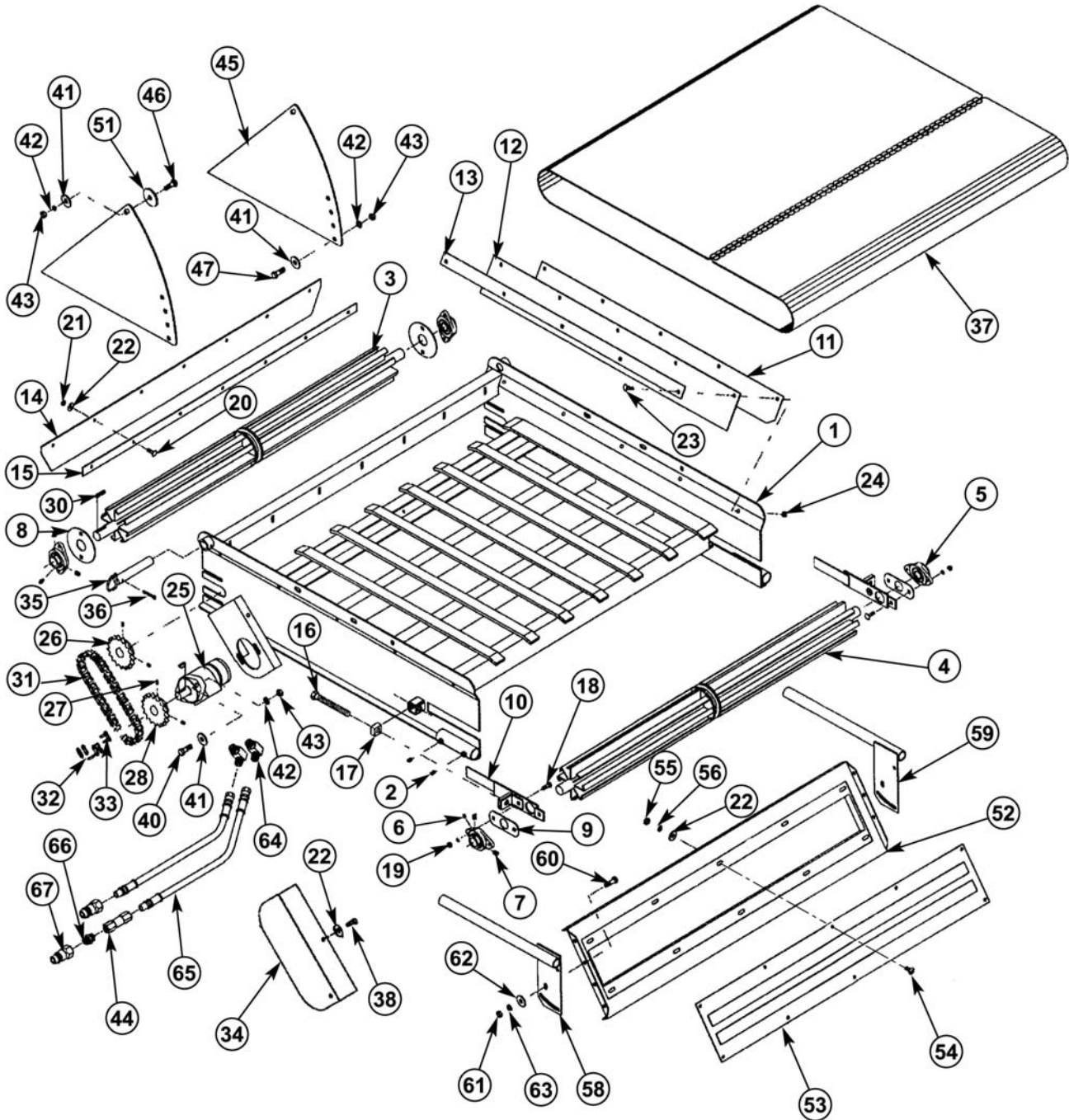

5205/5305/5380 - BELT DISCHARGE

Ref. No.	Part No.	Description	Qty. Req.	Ref. No.	Part No.	Description	Qty. Req.
1	167345	Discharge Frame 36" x 48"	1	33	500160	•Connector Link	1
	167340	Discharge Frame 36" x 60"	1	34	167014	Discharge Drive Cover	1
2	650214	••SHSS 3/8 x 1/2	4	35	167400	1" Connecting Pin	2
3	167213	Drive Guide Pulley 36"	1	36	655030	CP 1/4 x 2	2
4	167214	Idler Guide Pulley 36"	1	37		Belt w/Splice	
5	167623	2 Hole Flange Bearing 1-1/4" Bore	4		167195	36" x 96" Lg. (48" Lg. Discharge)	1
6	570019	•Grease Fitting 1/4 x 17/32	1		167212	36" x 120" Lg. (60" Lg. Discharge)	1
7	650342	•SHSS CP 5/16x1/2 F	2	38	650488	CS 3/8 x 3/4	2
8	167036	Bearing End Washer	2	22	654004	FW 5/16	2
9	167037	Slide Strip	2	40	650453	CS 1/2 x 1-1/2	2
10	167039	Take Up Slide	2	41	654009	FW 1/2	2
11		Side Strip		42	654030	LW 1/2	2
	167318	48" Lg. Discharge	2	43	653018	HN 1/2	2
	167321	60" Lg. Discharge	2	44	167250	Check Valve 3/4 O-Ring Boss	1
12		Side Flap		45	167337	Discharge Support Wing	2
	167319	48" Lg. Discharge	2	46	650834	CB 1/2 x 1-1/2	2
	167322	60" Lg. Discharge	2	47	650495	CS 1/2 x 1-1/4	2
13		Backing Strip		41	654009	FW 1/2	4
	167320	48" Discharge	2	42	654030	LW 1/2	4
	167323	60" Discharge	2	43	653018	HN 1/2	4
14	167639	Hopper Rear Flap	1	51	054042	Washer 17/32 ID	2
15	167408	Rear Flap Backer	1		166987	•Pan With Magnet	1
16	166933	HTB 5/8 x 5-1/2	2	52	167650	•Magnet Pan 36	1
17	166972	Square Nut 5/8	2	53	167338	•Magnet Assembly 34-3/8	1
18	650786	CB 3/8 x 1-1/4	AR	54	650949	•THMS Slotted 5/16 x 3/4	10
19	067847	HLN 3/8	AR	55	653007	•HN 5/16	10
20	650573	CB 5/16 x 1	7	56	654024	•LW 5/16	10
21	064260	HLN 5/16	7	22	654004	•FW 5/16	10
22	654004	FW 5/16	7	58	167283	•Pan Bracket RH	1
23	650687	CB 5/16 x 3/4	8	59	167282	•Pan Bracket LH	1
24	070648	HN FI S-Lock 5/16	8	60	650490	•CS 3/8 x 1	4
25	167173	Hydraulic Motor	1	61	653010	•HN 3/8	4
26	167000	Sprocket, 60B17 1-1/4" Bore	1	62	654006	•FW 3/8	4
27	650201	•SHSS 5/16 x 5/16	2	63	654026	•LW 3/8	4
28	167303	Sprocket, 60B17 1" Bore	1	64	076031	90° Elbow 7/8-14-3/4-16 FL	2
27	650201	•SHSS 5/16 x 5/16	2	65	167033	1/2 Hyd. Hose w/Ends x 156	2
30	B11156	Square Key 5/16 x 1-1/4	1	66	167032	O-Ring Hex. Nipple	1
31	141335	Roller Chain #60 x 39 Links	1	67	154615	Male Tip 3/4-16 O-Ring Boss	2
32	500161	•Offset Link	1				

5205/5305/5380 - AUGER DISCHARGE

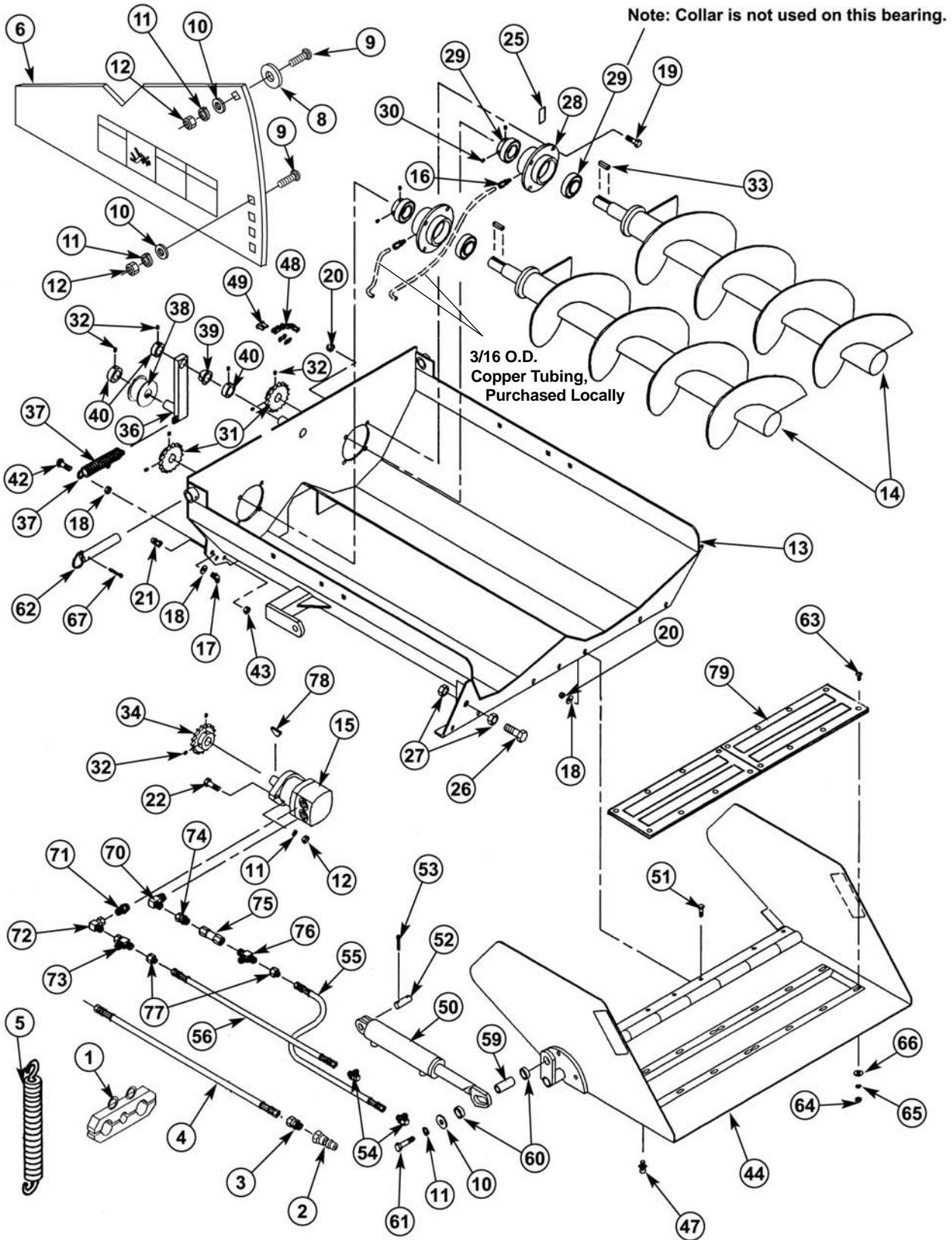

5205/5305/5380 - AUGER DISCHARGE

Ref. No.	Part No.	Description	Qty. Req.	Ref. No.	Part No.	Description	Qty. Req.
1	166998	•Dual Tube Clamp W/Eyebolts	1	40	S16174	••Set Collar	3
2	154615	•Male Tip 3/4 O-Ring Boss	2	32	650201	••SHSS 5/16 x 5/16	1
3	167391	•Swivel Adapter 1/2 NPT-SAE #8	2	42	650773	••CB 3/8 x 1-1/2	1
4	167233	•1/2" Hyd. Hose w/Ends x 198 Lg	2	43	653010	••HN 3/8	2
5	167301	•Extension Spring	2	44	167099	••Spout Assembly	1
6	167053	••Side Extension, (27-1/2")	2	47	570014	••Grease Fitting, 1/4-28NFStr	4
	167054	••Side Extension, (42-1/2")	2	48	066914	••Roller Chain #60 x 84 Links	1
8	054042	••Washer 17/32	2	49	500160	••Connector Link	1
9	650527	••CB 1/2 x 1-1/4	4	50	167087	••6-1/2 Stroke Cylinder	1
10	654009	••FW 1/2	4	51	650533	••CS 3/8 x 1-1/2	7
11	654030	••LW 1/2	4	52	167284	••Pin	1
12	653018	••HN 1/2	4	53	655020	••CP 3/16 x 1-1/2	2
13	167372	••Discharge Frame (27-1/2")	1	54	068938	••90° Elbow, 9/16 w/Adj. O.R.B	2
	167371	••Discharge Frame (42-1/2")	1	55	167076	••1/4 Hyd. Hose w/ends x 48 Lg (27-1/2" Discharge)	1
14		••Discharge Auger					
	167088	26" (27-1/2" Discharge)	2		167059	••1/4 Hyd. Hose w/ends x 60 Lg (42-1/2" Discharge)	1
	167078	41" (42-1/2" Discharge)	2				
15	167041	••Hydraulic Motor, 14.9 C.I.D	1	56	167094	••1/4 Hyd. Hose w/ends x 36 Lg (27-1/2" Discharge)	1
16	580069	••Male Connector 1/8-27NPT	2		167076	••1/4 Hyd. Hose w/ends x 48 Lg (42-1/2" Discharge)	1
17	570010	••Grease Fitting 1/8 x 65° Angle	2				
18	654006	••FW 3/8	9	59	167097	••Spacer	1
19	166934	•HTB 3/8 x 1-1/4	8	60	167285	••Pipe Spacer	2
20	067847	••HLN 3/8	15	61	650379	••CS 1/2 x 3	1
21	167002	••Female Connector 1/8 x 3/16 O.D	2	62	167400	•Connecting Pin	2
22	650569	••CS 1/2 x 1-3/4	2	63	650949	••THMS 5/16 x 3/4	10
12	653018	••HN 1/2	2	64	653007	••HN 5/16	10
11	654030	••LW 1/2	2	65	654024	••LW 5/16	10
25	167652	••Auger Shim	AR	66	654004	•FW 5/16	10
26	650416	••CS 3/4 x 2-1/2	1	67	655030	•CP 1/4 x 2	2
27	653026	••HN 3/4	2	10	654009	••FW 1/2	1
28	167241	••Bearing Housing	2	11	654030	••LW 1/2	1
29	069485	••Ball Bearing 1-7/16	4	70	076031	••90° Elbow, 7/8 x 3/4	1
	520093	••Collar	4	71	089099	••Male Connector, 7/8 ORB 3/4-16	1
30	650195	••SHSS 1/4 x 1/4	2	72	088442	••90° Elbow 3/4-16w/Fem. Swivel	1
31	167000	••Sprocket, 60B17 x 1 -1/4 Bore	2	73	076143	••Tee, 3/4 w/Female Run Swivel	1
32	650201	••SHSS 5/16 x 5/16	2	74	167306	••Swivel Adap. 3/4 Fl. x 3/4 O-Ring	1
33	B11156	••Square Key 5/16 x 1-1/4	2	75	167250	••Check Valve, 3/4 O-Ring Boss	1
34	167303	••Sprocket, 60B17 x 1 Bore	1	76	167307	••Tee 3/4 w/Adj. ORB Run	1
32	650201	••SHSS 5/16 x 5/16	2	77	167236	••Adapter, 3/4 - 9/16 (37°)	2
36	167095	••Discharge Idler	1	78	650513	••Woodruff Key 1/4 x 1	1
37	166980	••Extension Spring	1	79	167338	••Magnet Assy. 34-3/8	1
38	167229	••#80 Idler wheel 1" Bore	1	32	650201	••SHSS 5/16 x 5/16	2
39	167242	••Bearing, Sleeve 1" Bore	1				

5205/5305/5380 - SCALES

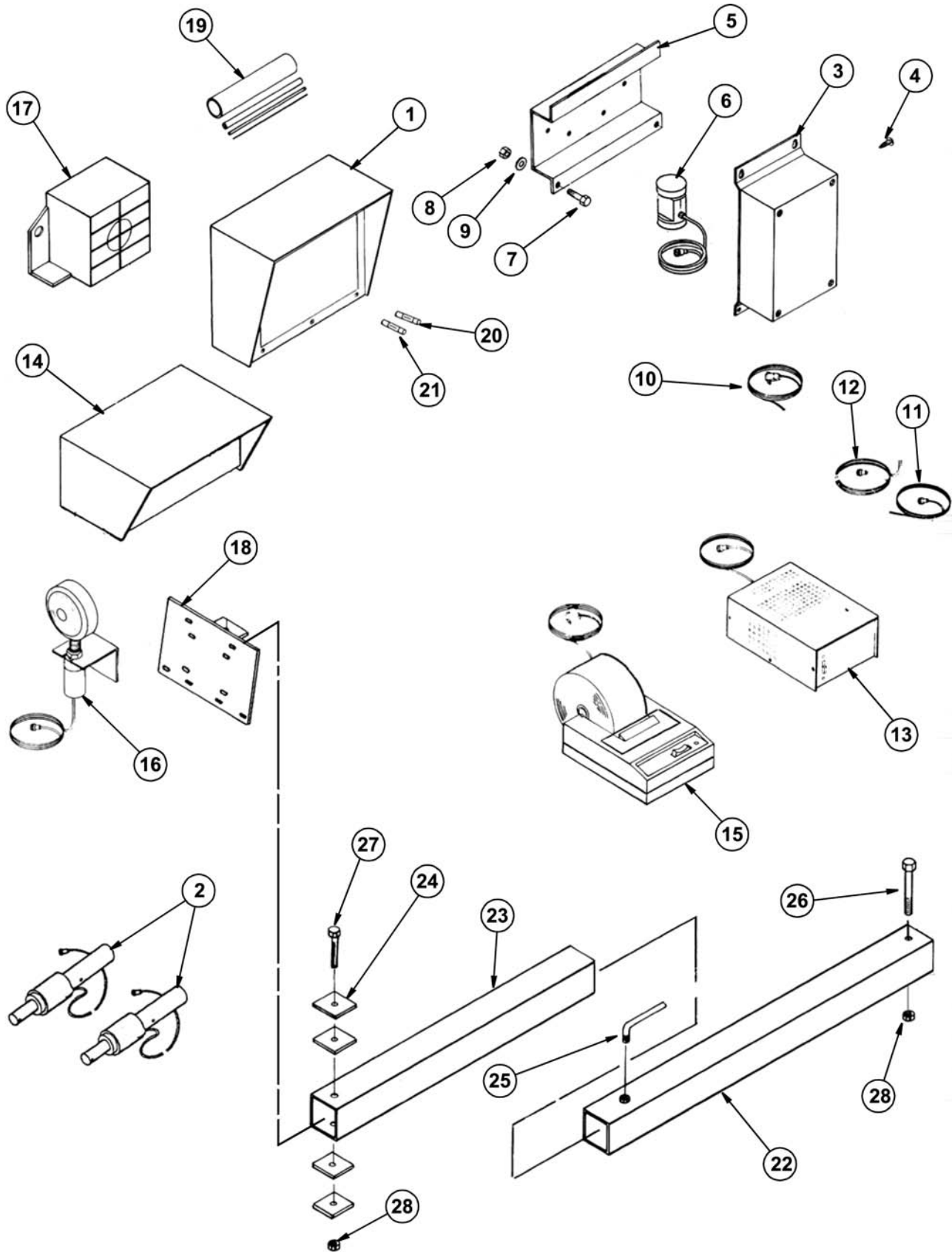

5205/5305/5380 - SCALES

Ref. No.	Part No.	Description	Qty. Req.	Ref. No.	Part No.	Description	Qty. Req.
1		EZ [®] 2000 Indicator			167199	EZ [®] Power Cable 22'	
	167464	Standard	1			w/Quick Disconnect	1
	167465	w/REM/SER/TR	1	11	167201	•EZ [®] Tractor Power Cable	1
		EZ [®] 2000 V Indicator		12	600798	•Tractor Power Cable Plug	1
	167466	Standard	1	13	099951	AC/DC Power Converter, 4 amp	1
	167467	w/REM/SER/TR	1	14		EZ [®] R Remote Displays	
		EZ [®] 3200 Indicator			167472	RD-2000 (1" display)	1
	167468	Standard	1		167473	RD-2000 w/TR (1" display)	1
	167469	w/RC/REM/SER/TR	1		167660	RD-2000 (1.7" display)	1
		EZ [®] 3200 V Indicator			167474	RD-2000 w/TR (1.7" display)	1
	167470	Standard	1	15	167200	EZ [®] Printer w/25' Cable	1
	167471	w/RC/REM/SER/TR	1	16	093067	EZ [®] Alarm (Light w/10' Cable)	1
2	099238	•EZ [®] Weigh Bar, 2-1/8" Dia.		17	093068	EZ [®] Alarm (Horn w/10' Cable)	1
		w/21' Cable	4	18	167270	Indicator Plate Assy	1
3	167202	EZ [®] J-Box w/30' Cable (Stationary) . . .	1	19	081710	Scale Cord Kit	AR
	092679	EZ [®] J-Box w/15' Cable (Mobile)	1	20	167645	5 Amp Fuse	1
4	651601	Screw, Self Drilling #10 x 1/2	4	21	167646	10 Amp Fuse	1
5	167203	EZ [®] Indicator Mount	1			Indicator Extension Arm	
6	167635	EZ [®] 30 Load Cell w/30' Cable	4	22	167415	•Indicator Bar Assy	1
7	650835	CS 1/4 x 1	2	23	167268	•Indicator Bar Ext	1
8	653005	HN 1/4	2	24	167267	•Indicator Bar Cushion	4
9	654022	LW 1/4	2	25	167038	•L-Handle Setscrew, 3/8" Dia	1
10		EZ [®] Power Cable		26	650653	•CS 1/2 x 4-1/2	1
	167197	12' w/Y plug	1	27	650744	•CS 1/2 x 4	1
	110218	10' w/4 wires	1	28	068034	•HLN 1/2	2

5205/5305/5380 - LIGHTS

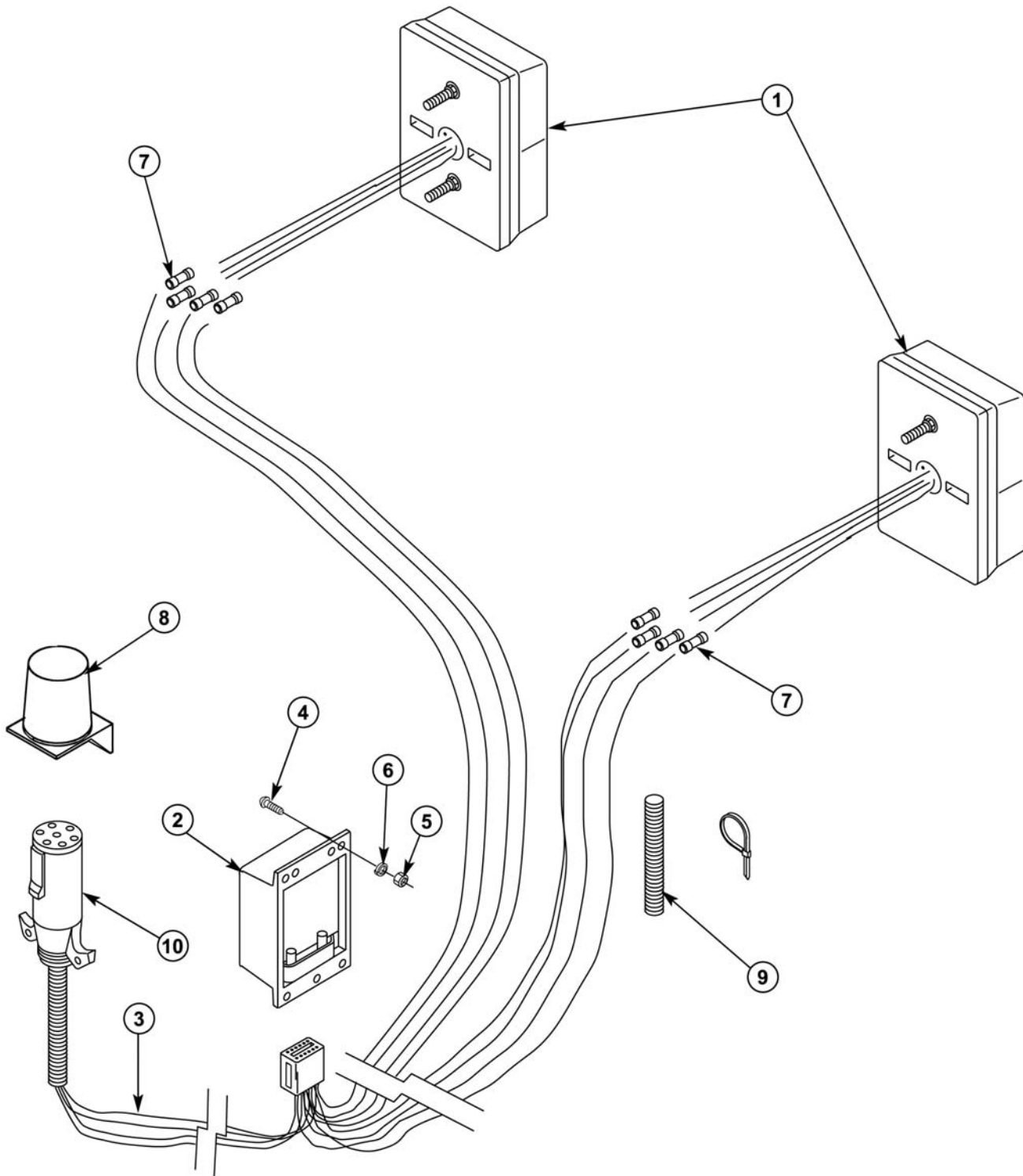

5205/5305/5380 - LIGHTS

Ref. No.	Part No.	Description	Qty. Req.	Ref. No.	Part No.	Description	Qty. Req.
1	167714	•Combination Tail Lamp	2	6	654022	•LW #8 S.S.	8
2	156836	•Lamp Interface Module	1	7	119926	•Connector Kit/Mp/280/6	10
3	167519	•Wiring Harness (Includes 7 Pin Connector and 12 Pin Connector)	1	8	112886	•Connector Plug Holder	1
4	651056	•RHMS Slotted #8-32 x 3/4	4	9	167637	Split Wire Loom, 3/8 I.D.	25'
5	653002	•HN #8-32	4	10	112917	Plug/7-Pin W/Cable Protector	1

5205/5305/5380 - BUMPER, FENDER & FLOOD LIGHT

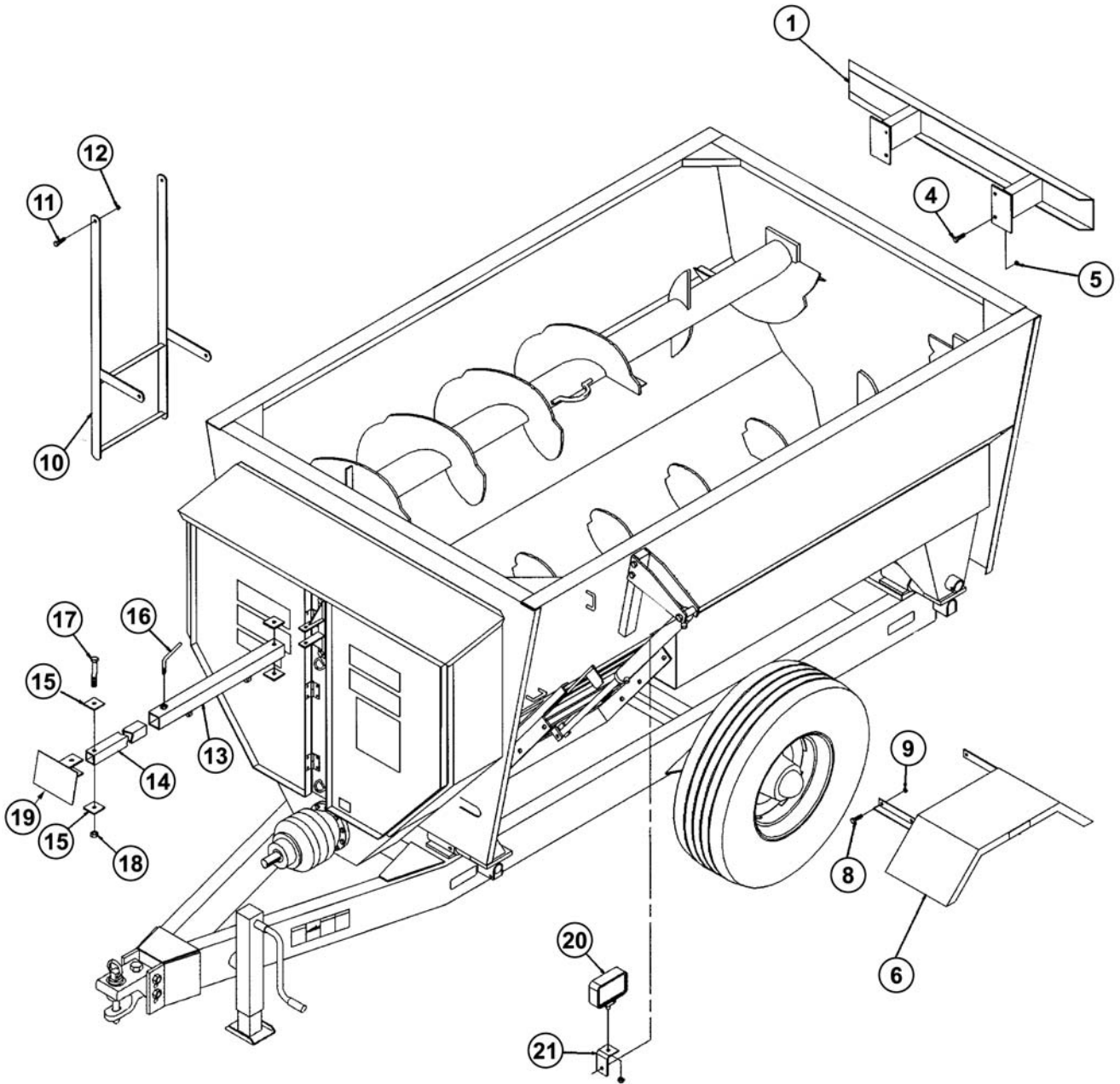

5205/5305/5380 - BUMPER, FENDER & FLOOD LIGHT

Ref. No.	Part No.	Description	Qty. Req.	Ref. No.	Part No.	Description	Qty. Req.
1	167692	Bumper Assembly (5205)	AR		167834	Indicator Extension Arm	AR
	167759	Bumper Assembly (5305/5380)	AR	13	167415	•Indicator Bar Assembly	1
4	650495	•CS 1/2 x 1-1/4	4	14	167268	•Indicator Bar Extension	1
5	068034	•HLN-Ins 1/2	4	15	167267	•Indicator Bar Cushion	4
6	167726	Fender (5205/5305)	AR	16	167038	•L-Handle Setscrew	1
	167725	Fender (5380)	AR	17	650744	•CS 1/2 x 4	1
8	650490	•CS 3/8 x 1	4	18	068034	•HLN-Ins 1/2	4
9	067847	•HLN-Ins 3/8	4	19	167270	•Indicator Plate Assy.	1
10	167276	Ladder Assembly	AR		167815	Discharge Flood Light	AR
11	650495	•CS 1/2 x 1-1/4	4	20	167228	•Flood Lamp	1
12	068034	•HLN-Ins 1/2	4	21	167003	•Flood Lamp Mount	1

Hydraulic Height Control
(for 48" and 60" Belt Discharge)

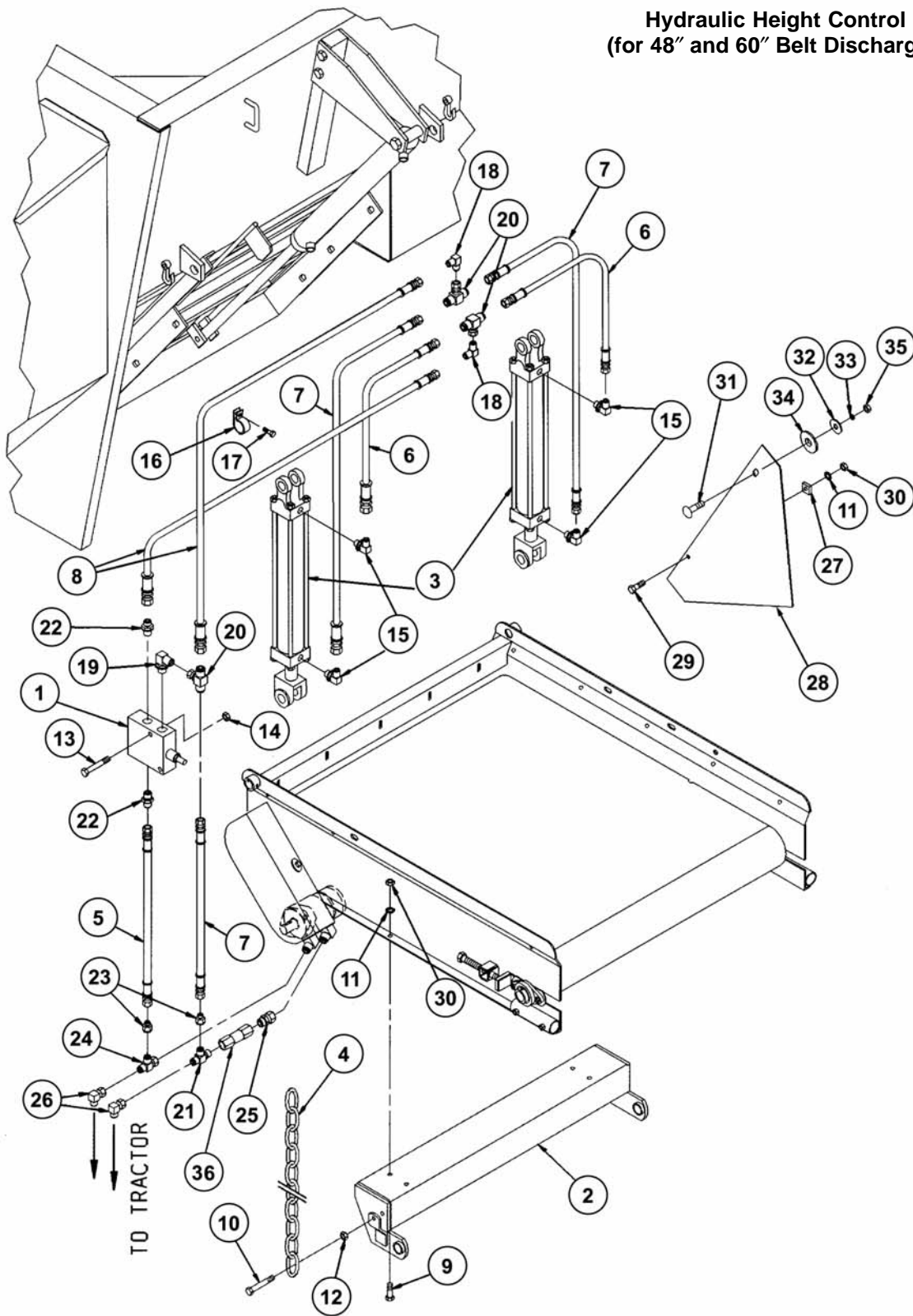

5205/5305/5380 - ACCESSORIES

Ref. No.	Part No.	Description	Qty. Req.	Ref. No.	Part No.	Description	Qty. Req.
	167786	Hydraulic Height Control	AR	19	068938	•90° Elbow 9/16-18 w/Adj. Orb.	1
1	167401	•Pressure Reducing Valve	1	20	095457	•Tee 9/16 w/Female Swivel	3
2	167329	•Hydraulic Lift Base	1	21	167307	•Tee 3/4-16 w/Adj. O.R.B. on Run	1
3	167328	•Hyd. Cylinder 2" Bore 16" Stroke	2	22	167237	•Adapter 9/16" O-Ring w/9/16" Flare ..	2
4	167247	•Chain	2	23	167236	•Adapter 3/4-16 9/16-18 (37°)	2
5	167096	•1/4" Hyd. Hose w/Ends x 42"	1	24	076143	•Tee 3/4-16 w/Fem. Swivel	1
6	166991	•Hose/Assy 1/4 x 30	2	25	167306	•Swivel Adap. 3/4 Fl. 3/4 O-Ring	1
7	167076	•1/4" Hyd. Hose w/Ends x 48"	3	26	088442	•90° Elbow 3/4-16 w/Fem. Swivel	2
8	167059	•1/4" Hyd. Hose w/Ends x 60"	2	27	058876	•Spacer	2
9	650490	•CS 3/8 x 1	4	28	167330	•Side Extension	2
10	167253	•CS 3/8 x 2-1/4	2	29	166934	•HTB 3/8 x 1-1/4	2
11	654026	•LW 3/8	6	30	653010	•HN 3/8	6
12	067847	•HLN-Ins 3/8	2	31	650834	•CB 1/2 x 1-1/2	2
13	650419	•CS 1/4 x 1-3/4	2	32	654009	•FW 1/2	2
14	071700	•LN 1/4	2	33	654030	•LW 1/2	2
15	057650	•90° Elbow 3/8 NPT Male 9/16 Flare Male	4	34	054042	•Washer, Plain 5/8 Std.	2
16	167235	•7/8" Dia. Cushioned Loop Clamp	2	35	653018	•HN 1/2	2
17	651602	•Self Tapping Screw 1/4 x 1/2	1	36	167250	•CHECK VALVE 3/4-16 O-RING	1
18	167260	•90° Elbow 9/16 Flare	2			(NOT INCLUDED IN 167786 KIT. COMES STANDARD WITH BELT DISCHARGE)	

5205/5305/5380 - ACCESSORIES

Pressure Relief Kit (For Discharge Door)

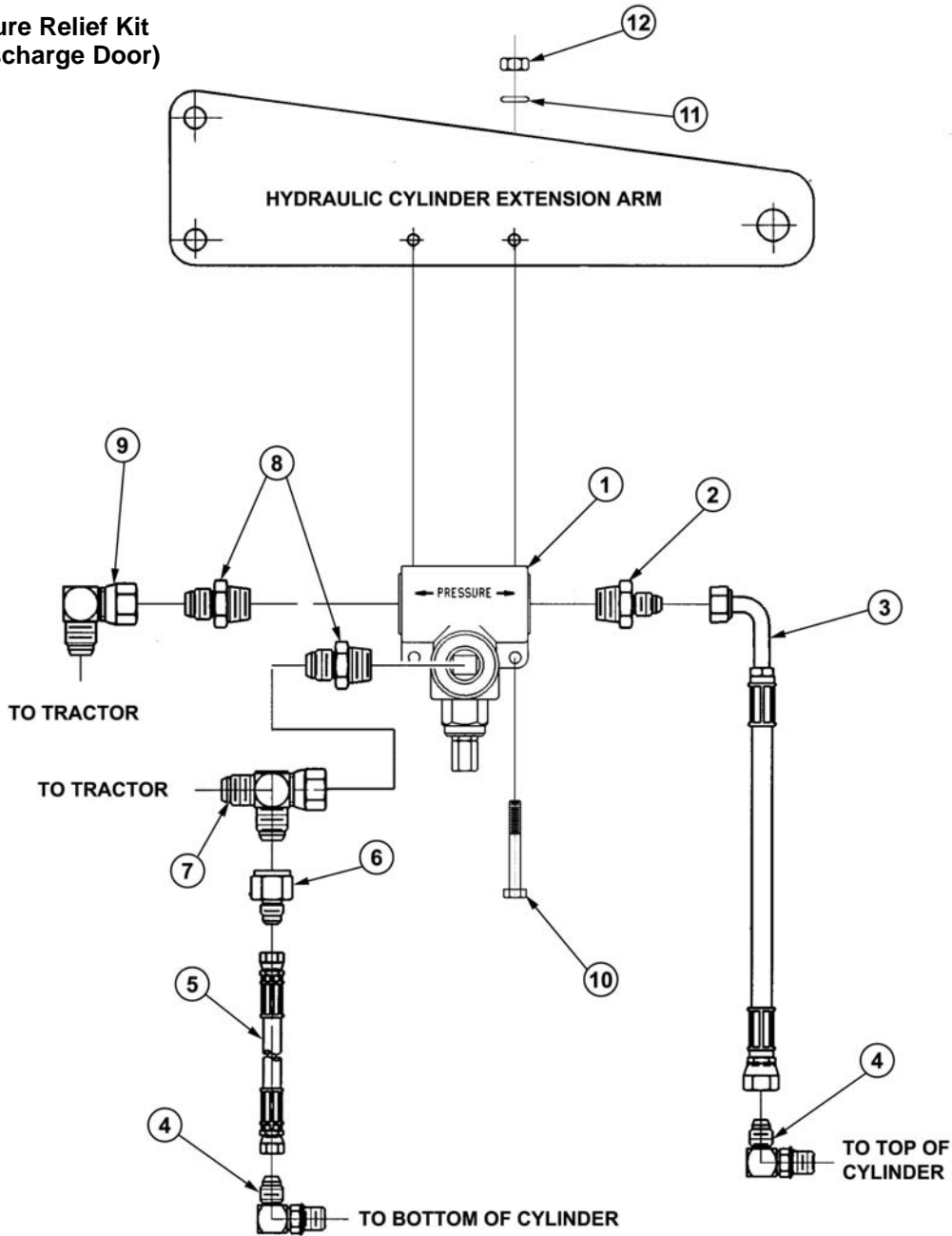

Ref. No.	Part No.	Description	Qty. Req.	Ref. No.	Part No.	Description	Qty. Req.
1	167226	Relief Valve Single	1	7	076143	Tee, 3/4-16 w/Fem. Swivel	1
2	167280	Male Connector 3/4NPT x 9/16-18FL	1	8	074281	Male Connector 3/4NPT x 3/4-16FL	2
3	167421	1/4" Hyd. Hose w/Ends x 12" Lg.	1	9	088442	Elbow, 90° 3/4-16 w/Fem. Swivel	1
4	068938	Elbow, 90° 9/16-18FL x 9/16-18 O.R.B	2	10	650706	CS 1/4 x 2	2
5	167094	1/4" Hyd. Hose w/Ends x 36" Lg.	1	11	654022	LW 1/4	2
6	167236	Adapter 3/4-16 x 9/16-18 37° FL.	1	12	653005	HN 1/4	2

Ref. No.	Part No.	Description	Qty. Req.
	142967	15-Ton Safety Tow Chain	1
		Consists of:	
1	650695	CS 5/8X3-1/2	1
2	080894	Clevis	1
3	654032	LW 5/8	1
4	653021	HN 5/8	1
5	653026	HN 3/4	1
6	654034	LW 3/4	1
7	654014	FW 3/4	1
8	069076	FW 25/32	1
9	651073	CS 3/4X3-1/4 GR8	1
10	043912	FW 1-1/32	1

Safety Tow Chain - 15-Ton

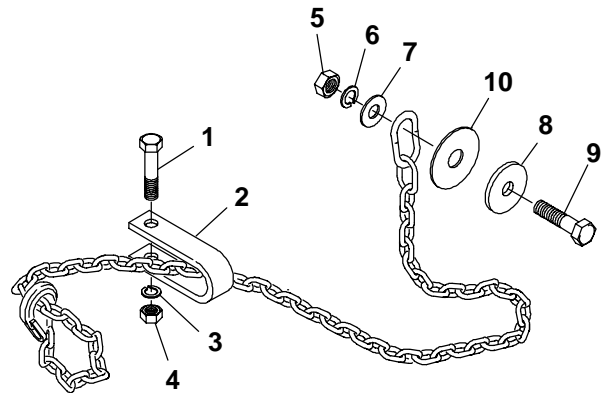

Index

A

Accessories
Hydraulic Height Control, 28–29
Pressure Relief Kit, 30
Safety Chain, 31
Auger Discharge, 20–21
Auger, Stub Shafts & Bearings,
8–9

B

Belt Discharge, 18–19

D

Decal Locations, 2–7

Decals

Application, 2
Set numbers, 2
Doors, 12–13

F

Bumper, 26–27
Fender, 26–27
Flood Light, 26–27
Front Drive, 10–11

L

Lights, 24–25

P

Paint Notice, 2
PTO Shaft, 16–17

S

Scales, 22–23
Subframe, 12–13

T

Tires & Wheels, 14–15
Trailer Frame, 14–15

W

Weighbars, 14–15

5205/5305/5380 - NUMERICAL INDEX

Part No.	Page No.	Ref. No.	Part No.	Page No.	Ref. No.	Part No.	Page No.	Ref. No.	Part No.	Page No.	Ref. No.
B11156	19	30	079209	13	25	145218	02	15	167041	21	15
B11156	21	33	080894	31	02	145234	02	16	167046	13	20
S16174	11	17	081710	23	19	154615	13	31	167047	11	11
S16174	21	40	086910	17	03	154615	19	67	167048	11	11
003938	15	15	086910	17	15	154615	21	02	167048	11	13
003940	15	12	086921	17	13	156836	25	02	167050	15	21
003943	15	19	086921	17	28	163941	02	17	167053	21	06
004375	15	08	086922	17	29	163962	02	18	167054	21	06
042162	15	07	086943	17	23	163969	02	19	167057	15	10
042163	15	13	088442	21	72	166933	19	16	167059	21	55
043912	31	10	088442	29	26	166934	21	19	167059	29	08
054042	19	51	088442	30	09	166934	29	29	167065	13	23
054042	21	08	089099	21	71	166972	19	17	167066	11	12
054042	29	34	091438	02	01	166980	11	26	167072	09	20
057650	29	15	091444	02	02	166980	21	37	167076	21	55
058876	29	27	092679	23	03	166987	19	00	167076	21	56
064260	19	21	093067	23	16	166988	13	50	167076	29	07
066914	21	48	093068	23	17	166990	09	36	167078	21	14
067847	19	19	093367	02	03	166990	09	36	167081	15	19
067847	21	20	093373	02	04	166991	29	06	167087	21	50
067847	27	09	093457	02	05	166998	21	01	167088	21	14
067847	29	12	093466	02	00	167000	19	26	167094	21	56
068034	11	44	093653	02	07	167000	21	31	167094	30	05
068034	13	27	094914	02	08	167001	11	12	167095	21	36
068034	23	28	095457	29	20	167002	11	47	167096	29	05
068034	27	05	099238	23	02	167002	21	21	167097	21	59
068034	27	12	099951	23	13	167003	27	21	167099	21	44
068034	27	18	110218	23	10	167009	11	38	167102	17	04
068938	21	54	112444	15	26	167010	09	32	167102	17	16
068938	29	19	112886	25	08	167014	19	34	167105	17	18
068938	30	04	114824	13	30	167015	11	25	167110	17	07
069076	31	08	119926	25	07	167017	11	20	167110	17	20
069485	21	29	120399	02	09	167018	11	22	167113	17	05
070648	19	24	120403	15	09	167019	11	25	167130	09	23
071700	29	14	120433	15	08	167021	15	12	167133	09	43
071706	15	23	120434	15	13	167024	11	38	167153	09	12
071709	15	23	120617	15	15	167032	19	66	167158	09	14
074281	30	08	122617	02	10	167033	19	65	167169	09	12
076031	19	64	122736	02	11	167033	19	65	167169	09	13
076031	21	70	141268	15	26	167034	13	29	167170	09	13
076143	21	73	141335	19	31	167035	13	28	167173	19	25
076143	29	24	142967	15	36	167036	19	08	167195	19	37
076143	30	07	142967	31	00	167037	19	09	167196	09	12
078657	15	09	143007	02	12	167038	23	25	167197	23	10
078943	15	07	145216	02	13	167038	27	16	167199	23	00
078947	15	14	145217	02	14	167039	19	10	167200	23	15
						167040	09	15	167201	23	11

5205/5305/5380 - NUMERICAL INDEX

Part No.	Page No.	Ref. No.	Part No.	Page No.	Ref. No.	Part No.	Page No.	Ref. No.	Part No.	Page No.	Ref. No.
167202	23	03	167283	19	58	167354	09	01	167442	09	04
167203	23	05	167284	21	52	167355	09	05	167442	09	04
167212	19	37	167285	21	60	167371	21	13	167447	09	17
167213	19	03	167286	17	17	167372	21	13	167448	09	17
167214	19	04	167293	15	26	167373	15	21	167449	11	01
167215	13	11	167294	15	26	167374	09	02	167450	11	01
167216	11	05	167297	17	19	167374	09	02	167451	11	05
167226	30	01	167299	17	08	167375	09	03	167453	09	17
167227	15	14	167300	17	21	167375	09	03	167455	11	27
167228	27	20	167301	21	05	167376	09	11	167464	23	01
167229	11	16	167303	19	28	167377	09	02	167465	23	01
167229	21	38	167303	21	34	167377	09	02	167466	23	01
167230	11	24	167305	11	05	167377	09	02	167467	23	01
167233	21	04	167306	21	74	167377	09	02	167468	23	01
167235	29	16	167306	29	25	167378	09	03	167469	23	01
167236	21	77	167307	21	76	167378	09	03	167470	23	01
167236	29	23	167307	29	21	167378	09	03	167471	23	01
167236	30	06	167308	09	04	167378	09	03	167472	23	14
167237	29	22	167308	09	04	167379	09	11	167473	23	14
167239	15	28	167318	19	11	167379	09	11	167474	23	14
167241	21	28	167319	19	12	167380	09	10	167519	25	03
167242	11	19	167320	19	13	167380	09	10	167623	19	05
167242	21	39	167321	19	11	167385	11	08	167635	23	06
167244	13	51	167322	19	12	167385	11	10	167637	25	09
167245	13	51	167323	19	13	167386	11	03	167639	19	14
167247	29	04	167324	17	00	167388	11	08	167641	15	37
167250	19	44	167326	17	14	167390	11	08	167645	23	20
167250	21	75	167327	17	01	167391	21	03	167646	23	21
167250	29	36	167328	29	03	167394	13	45	167650	19	52
167251	15	29	167329	29	02	167395	09	26	167652	09	16
167253	29	10	167330	29	28	167396	13	17	167652	21	25
167260	29	18	167333	09	40	167397	13	12	167654	09	00
167267	23	24	167334	11	03	167398	13	13	167660	23	14
167267	27	15	167335	11	03	167400	19	35	167671	11	15
167268	23	23	167337	19	45	167400	21	62	167672	11	22
167268	27	14	167338	19	53	167401	29	01	167676	11	36
167269	13	32	167338	21	79	167408	19	15	167677	13	57
167270	13	33	167340	19	01	167415	23	22	167679	15	41
167270	23	18	167345	19	01	167415	27	13	167680	15	46
167270	27	19	167347	09	09	167421	30	03	167681	15	45
167271	17	06	167348	09	01	167434	11	35	167682	15	44
167275	11	35	167349	09	05	167435	11	20	167683	09	10
167276	27	10	167350	09	09	167436	11	35	167684	11	06
167280	30	02	167351	09	01	167436	11	36	167685	11	06
167281	15	32	167352	09	05	167442	09	04	167686	11	30
167282	19	59	167353	09	09	167442	09	04	167687	15	00
									167691	13	37

5205/5305/5380 - NUMERICAL INDEX

Part No.	Page No.	Ref. No.	Part No.	Page No.	Ref. No.	Part No.	Page No.	Ref. No.	Part No.	Page No.	Ref. No.
167692	27	01	570009	15	02	650573	19	20	651601	23	04
167693	13	01	570010	21	17	650585	11	42	651602	29	17
167694	13	05	570014	21	47	650644	13	26	651608	09	24
167695	13	01	570019	19	06	650647	09	37	651615	09	27
167696	13	05	580069	11	46	650647	09	37	651616	09	21
167702	17	32	580069	21	16	650652	09	33	653002	25	05
167704	11	37	600798	23	12	650653	13	34	653005	13	16
167705	11	37	601032	11	21	650653	15	22	653005	23	08
167714	25	01	601237	11	21	650653	23	26	653005	30	12
167725	27	06	604330	15	10	650655	09	34	653007	11	34
167726	27	06	604725	17	09	650663	13	38	653007	13	55
167759	27	01	604725	17	22	650687	19	23	653007	19	55
167786	29	00	604728	17	24	650695	31	01	653007	21	64
167787	15	00	613982	17	02	650706	30	10	653010	11	29
167808	15	06	650195	21	30	650731	15	38	653010	13	49
167815	27	19	650200	11	18	650744	23	27	653010	15	40
167822	15	00	650201	19	27	650744	27	17	653010	19	61
167834	27	00	650201	19	27	650773	21	42	653010	21	43
167853	15	06	650201	21	32	650786	19	18	653010	29	30
167858	13	18	650201	21	32	650818	13	47	653018	13	22
167867	17	00	650201	21	32	650834	19	46	653018	19	43
167868	17	00	650214	19	02	650834	29	31	653018	19	43
170640	02	23	650342	19	07	650835	23	07	653018	21	12
170771	15	42	650379	21	61	650846	15	22	653018	29	35
170772	15	43	650416	09	29	650849	13	24	653021	09	39
170783	02	20	650416	21	26	650933	15	18	653021	09	39
170784	02	21	650419	29	13	650949	19	54	653021	31	04
170785	02	22	650424	11	42	650949	21	63	653026	09	31
170854	02	23	650453	19	40	651028	09	41	653026	15	34
170855	02	23	650484	15	17	651045	09	42	653026	21	27
500160	11	23	650487	11	31	651056	25	04	653026	31	05
500160	11	23	650487	13	52	651073	31	09	654004	11	32
500160	19	33	650488	19	38	651127	09	35	654004	13	53
500160	21	49	650490	19	60	651127	09	35	654004	19	22
500161	19	32	650490	27	08	651381	15	18	654004	19	22
500195	11	23	650490	29	09	651582	11	04	654004	19	22
500195	11	23	650495	13	35	651591	11	02	654004	21	66
520093	21	00	650495	19	47	651591	11	04	654006	09	44
570002	09	19	650495	27	04	651591	11	07	654006	11	28
570002	09	19	650495	27	11	651591	11	07	654006	19	62
570002	09	19	650513	21	78	651591	11	09	654006	21	18
570002	09	22	650526	15	30	651592	09	18	654009	13	36
570002	09	25	650527	21	09	651593	09	18	654009	19	41
570002	09	28	650533	21	51	651594	09	18	654009	19	41
570002	11	48	650542	13	14	651594	15	31	654009	21	10
570002	15	11	650569	21	22	651595	11	14	654009	21	10
						651597	09	18	654009	29	32





5205/5305/5380 - NUMERICAL INDEX

Part No.	Page No.	Ref. No.	Part No.	Page No.	Ref. No.	Part No.	Page No.	Ref. No.	Part No.	Page No.	Ref. No.
654014	31	07	654024	21	65	654030	21	11	654034	31	06
654022	13	15	654026	13	48	654030	21	11	654056	11	43
654022	23	09	654026	15	39	654030	29	33	655020	11	23
654022	25	06	654026	19	63	654032	09	38	655020	21	53
654022	30	11	654026	29	11	654032	09	38	655022	15	20
654024	11	33	654030	13	21	654032	31	03	655030	15	20
654024	13	54	654030	19	42	654034	09	30	655030	19	36
654024	19	56	654030	19	42	654034	15	33	655030	21	67

TORQUE SPECIFICATIONS

NOTE: Use these torque values when tightening **GEHL** hardware (excluding: Locknuts and Self-tapping, Thread Forming and Sheet Metal Screws) unless specified otherwise.

All torque values are in Lb-Ft except those marked with an * which are Lb-In
(For metric torque value Nm, multiply Lb-Ft value by 1.355 or Lb-In value by 0.113)

Unified National Thread	Grade 2 		Grade 5 		Grade 8 	
	Dry	Lubed	Dry	Lubed	Dry	Lubed
8-32 8-36	19* 20*	14* 15*	30* 31*	22* 23*	41* 43*	31* 32*
10-24 10-32	27* 31*	21* 23*	43* 49*	32* 36*	60* 68*	45* 51*
1/4-20 1/4-28	66* 76*	50* 56*	9 10	75* 86*	12 14	9 10
5/16-18 5/16-24	11 12	9	17 19	13 14	25	18 20
3/8-16 3/8-24	20 23	15 17	30 35	23 25	45 50	35
7/16-14 7/16-20	32 36	24 27	50 55	35 40	70 80	55 60
1/2-13 1/2-20	50 55	35 40	75 90	55 65	110 120	80 90
9/16-12 9/16-18	70 80	55 60	110 120	80 90	150 170	110 130
5/8-11 5/8-18	100 110	75 85	150 180	110 130	220 240	170 180
3/4-10 3/4-16	175 200	130 150	260 300	200 220	380 420	280 320
7/8-9 7/8-14	170 180	125 140	430 470	320 360	600 660	460 500
1-8 1-14	250 270	190 210	640 710	480 530	900 1000	680 740
Metric Course Thread	Grade 8.8 		Grade 10.9 		Grade 12.9 	
	Dry	Lubed	Dry	Lubed	Dry	Lubed
M6-1	8	6	11	8	13.5	10
M8-1.25	19	14	27	20	32.5	24
M10-1.5	37.5	28	53	39	64	47
M12-1.75	65	48	91.5	67.5	111.5	82
M14-2	103.5	76.5	145.5	108	176.5	131
M16-2	158.5	117.5	223.5	165.5	271	200

GEHL®

Gehl Company 143 Water Street, P.O. Box 179, West Bend, WI 53095-0179 U.S.A.
www.gehl.com