



# Dealer Set-up Instructions for 5000 Series 3-auger Mixer Feeders

These instructions provide details for unpacking and setting up a 5205, 5305 or 5380 Mixer Feeder. They should be retained by the dealer.

## GENERAL INFORMATION

5000 Series Mixer Feeders are shipped in varying stages of disassembly.

Unless otherwise noted, the standard fastening procedure is to secure two parts with a cap screw, lock washer and nut. A part with a mounting slot should be secured with a plain washer against the slotted surfaces. Lock nuts are sometimes used to prevent two parts from separating but still allow one part to move or rotate next to the other. Attaching hardware, if it will require installation in the path of material flow, should always be installed with the head of the screw on the same side of the part that will be in contact with the material.

## TRAILER MODELS

1. Install plug (1) in the threaded hole on the underside of the front drive compartment (2). Use sealant on the threads. Fig. 1

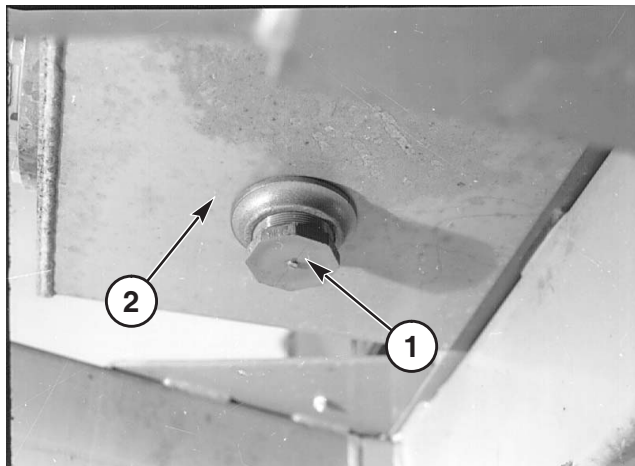

1 – Plug  
2 – Front Drive Compartment  
Fig. 1

2. Open the front drive compartment doors and add SAE 30W motor oil until it reaches the chain of the lower drive sprocket as shown. Front drive compartment oil capacity is approximately 6 gallons U.S. (22.7 L) for the model 5205 and is approximately 10 gallons U.S. (37.9 L) for the 5305 and 5380 models. Fig. 2

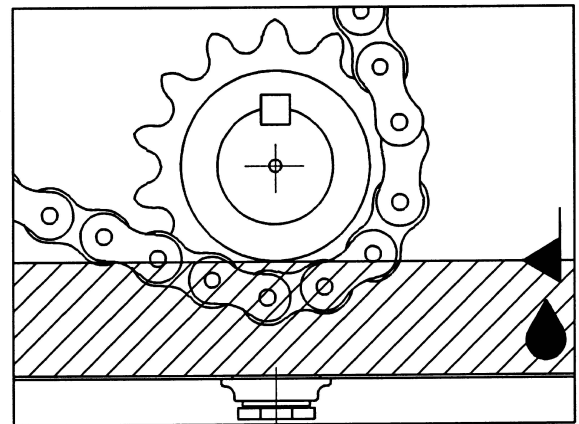
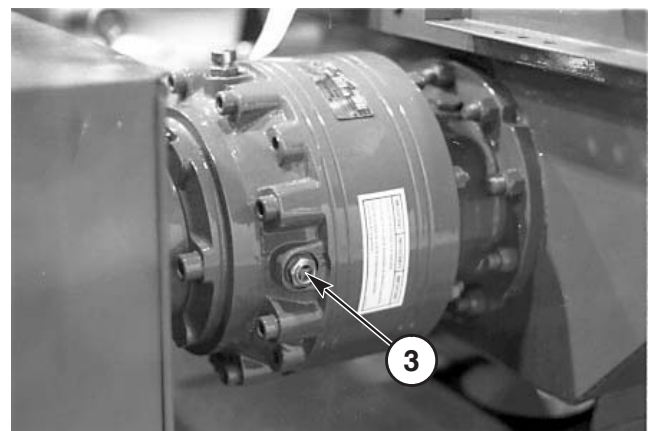

Fig. 2

3. Check the oil level in the planetary gearbox using the sight gauge (3) on the left side of the gearbox. Fig. 3



3 – Sight Gauge

Fig. 3

4. Install one plug (4) in the threaded hole on the rear underside of the mixing chamber (5). Fig. 4

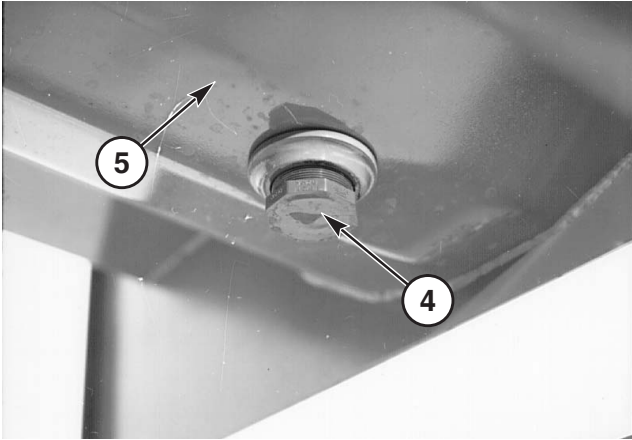

4 – Plug  
5 – Mixing Chamber

Fig. 4

5. Push in locking pin (8) and install the PTO shaft (6) on the planetary gearbox (7). Hook the PTO safety chain (9) onto the trailer tongue (10). Fig. 5

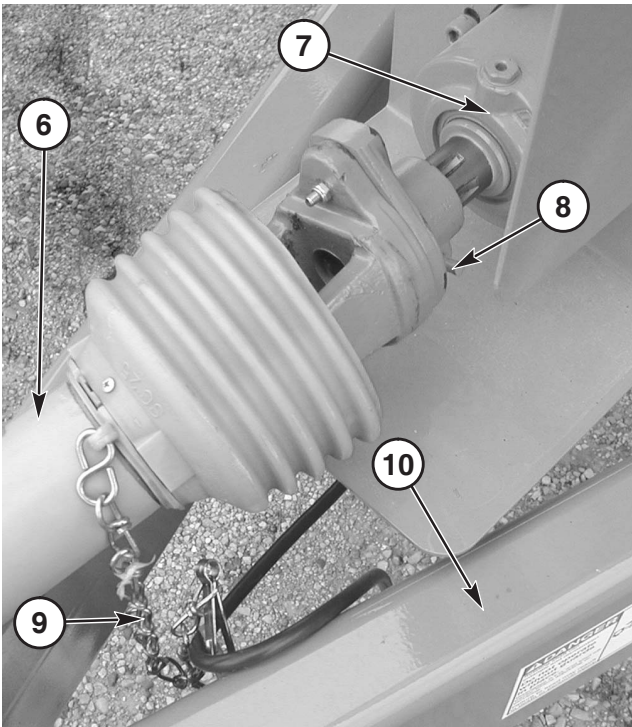

6 – PTO Shaft  
7 – Planetary Gearbox  
8 – Locking Pin  
9 – PTO Safety Chain  
10 – Trailer Tongue

Fig. 5

6. Check for proper assembly, adjustment and lubrication. Check all bolts and tighten as needed.
7. Be sure all shields are properly in place.
8. Check for and remove any foreign objects and tools in the mixing chamber, discharge chute, and oil bath reservoir area.

---

## **WARNING**

For implements without brakes, safety codes recommend that total weight of implement and load **DO NOT** exceed one-and-one-half (1-1/2) times the weight of the towing vehicle (Reference ASAE Standard S365). For any public highway travel, and to be in compliance with this rule, **BE SURE** that your tractor is heavy enough to counterbalance the weight of the Mixer Feeder and its load.

---

**NOTE:** See the Specifications section in the Operator's Manual for the weight of your Mixer Feeder.

9. Tractor drawbar (15) pin hole centerline must be 15-1/2" from the PTO shaft groove (11) for correct adjustment. Fig. 6

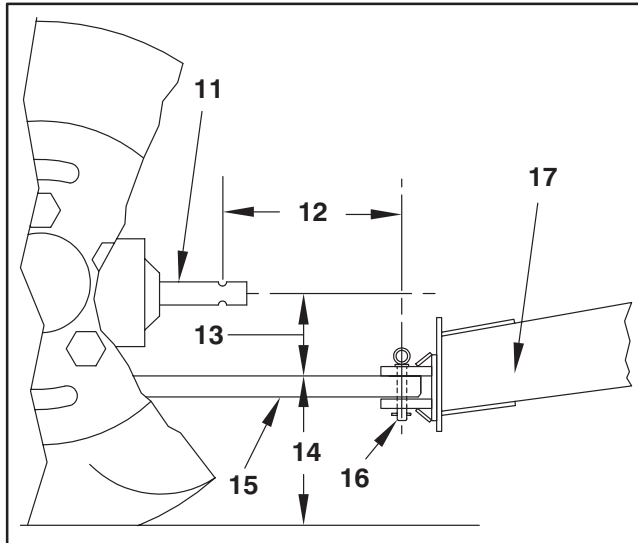

- 11 – Tractor PTO Shaft (Tractor MUST comply with ASAE Standard S203)
- 12 – 15-1/2" (394 mm) for 540 RPM
- 13 – 8 to 13" (203 to 330 mm) - 10" (254 mm) Standard
- 14 – 13 to 22" (330 to 559 mm)
- 15 – Tractor Drawbar
- 16 – Locking Hitchpin
- 17 – Trailer Tongue

Fig. 6

10. The hitch (18) may need to be adjusted up or down to obtain a level Mixer Feeder. Use the hitch jack to level the Mixer Feeder. Remove the nuts, lock washers and bolts, then move the hitch jaw up or down and reinstall the nuts, lock washers and bolts. Fig. 7



18 – Mixer Hitch

Fig. 7

11. For the standard hitch, locate the tractor drawbar (19) between the hitch (20), and install the locking hitch pin (22). Fig. 8

12. Install the safety chain (23). See the tractor Operator's Manual for recommendations. Fig. 8

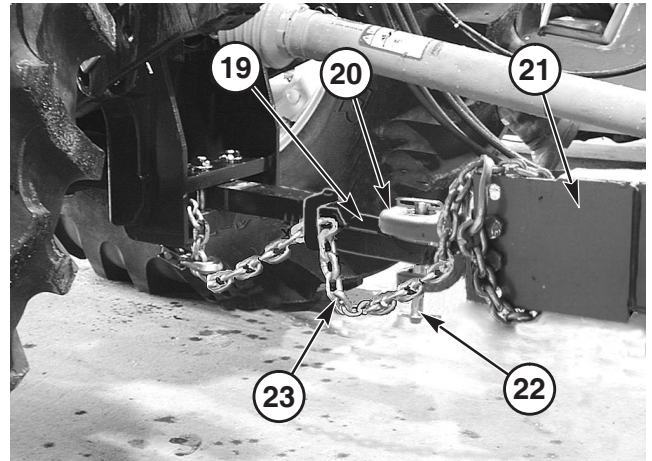

- 19 – Tractor Drawbar
- 20 – Mixer Hitch
- 21 – Trailer Tongue
- 22 – Locking Hitchpin
- 23 – Safety Chain

Fig. 8

13. Remove the hitch jack and store it in the hitch jack holder located at the rear of the unit and secure it in place by inserting the locking pin.
14. Slide the locking collar (24) back while pushing the PTO shaft (25) onto the tractor PTO shaft (26). The PTO shaft is in position when the locking collar snaps forward into place. Fig. 9

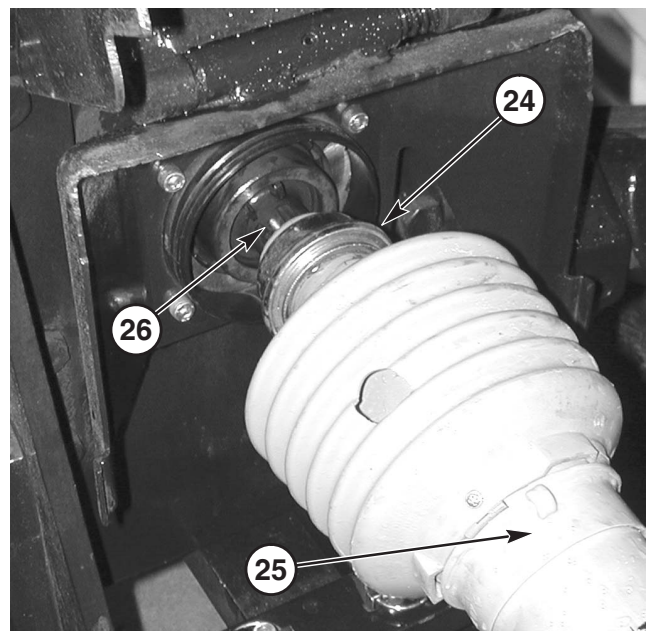

- 24 – Locking Collar
- 25 – PTO Shaft
- 26 – Tractor PTO Shaft

Fig. 9



15. Wipe off the hose couplings and tractor couplings with a clean cloth, and install the hydraulic hoses (27) to the couplings (28) on the tractor. Fig. 10
16. Test run the unit and check for proper hydraulic functions. The discharge door should go up and down and the discharge conveyor should turn on and off.
17. Remove the electrical seven-pin male connector (29) from the holder on the Mixer Feeder by pushing the connector in and turning it 90°, then pull it out. Install the electrical seven-pin male connector to the tractor. Fig. 10

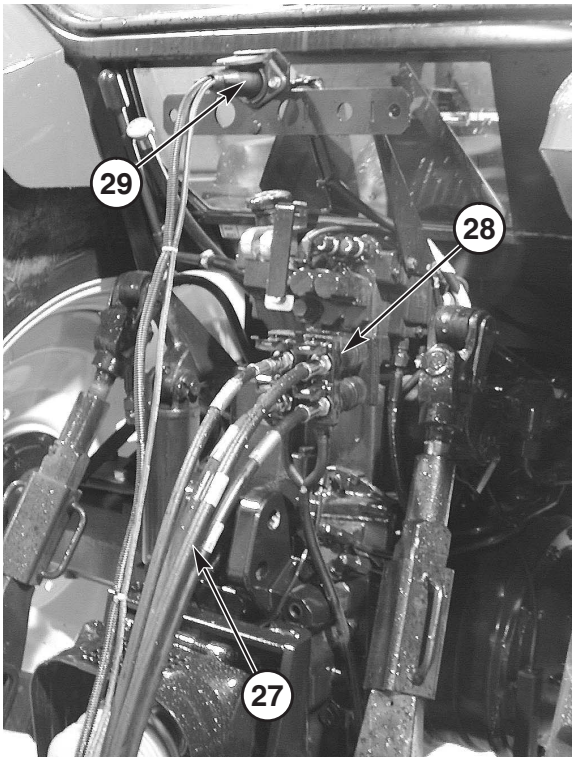

27 – Hydraulic Hoses  
 28 – Tractor Hydraulic Couplings  
 29 – 7-Pin Electrical Male Connector

Fig. 10

18. Check the lights for function. The lights, turn signals, brake lights and the flashing warning lights should work with the tractor's lights.

## ! WARNING

**ALWAYS** follow state and local regulations regarding the use of safety chain and auxiliary lighting when towing farm equipment on public highways. **ONLY** a safety chain (NOT an elastic or a nylon/plastic tow strap) should be used to retain the connection between the towing and towed machines, in the event of separation of the primary attaching system. **BE SURE** to check with local law enforcement agencies for your own particular regulations. Never tow a mixer on a public highway at a speed greater than 20 mph (32 km/h).

**IMPORTANT:** *The maximum angle of the wide-angle PTO joint must not exceed 80° under any condition of the driveline. Larger angles will result in joint damage. In continuous operation, an angle of 35° must not be exceeded.*

19. These maximum joint angles must be observed or serious injury and damage could occur. Fig. 11  
 Continuous operation – 35 Degrees  
 Non-rotating – 80 Degrees

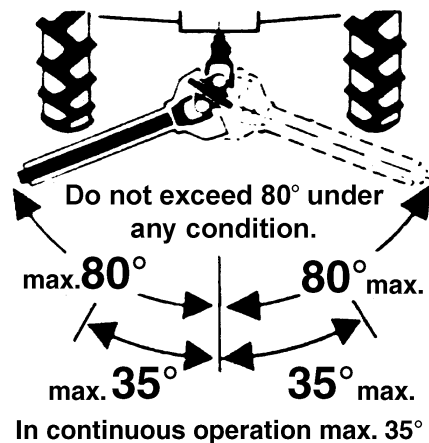

Fig. 11

20. Test run the unit and check for proper hydraulic action.

**IMPORTANT:** *Be sure the tractor PTO rotation is correct. Running the PTO in the opposite direction will cause damage. Correct rotation is clockwise when facing in the direction of forward travel.*

## TIRES AND WHEELS

Check the Mixer Feeder tire pressure after every 50 hours of operation. Tires should be inflated to the appropriate pressure listed in the table. Wheel lug torque should be checked after every 50 hours of operation and tightened to 85–100 ft-lb (115–136 Nm) for the 5205, 5305 models and to 175–200 ft-lb (237–271 Nm) for the 5380.

**Table of Tire Pressures**

Tire Size & Style	Inflation Pressures	
	PSI	kPa
10.00 x 20.0 Radial Recap Truck Tire	55	379
15.00 x 22.5 Radial Recap Truck Tire	85	586
16.50 x 22.5 Radial Recap Truck Tire	85	586
40 x 14 Used Aircraft Tire	85	586
44 x 16 Used Aircraft Tire	85	586



## WARNING

Tire mounting, repairing and replacing should **ONLY** be performed by a qualified tire manufacturer's representative, or by properly trained personnel following the tire manufacturer's instructions. If you do not have such instructions, contact your tire dealer or our Company.



## WARNING

**Inflating or servicing tires can be dangerous. Whenever possible, trained personnel should be called to service and mount tires. To avoid possible death or serious injury, follow the safety precautions below:**

- **BE SURE** the rim is clean and free of rust.
- Lubricate both the tire beads and rim flanges with a soap solution. **DO NOT** use oil or grease.
- Use a clip-on tire chuck with a remote hose and gauge, which allows you to stand clear of the tire while inflating it.
- **DO NOT** place your fingers on the tire bead or rim during inflation.
- **NEVER** inflate beyond 35 PSI (240 kPa) to seat the beads. If the beads have not seated by the time the pressure reaches 35 PSI, deflate the assembly, reposition the tire on the rim, relubricate both parts and re-inflate it. Inflation pressures beyond 35 PSI with unseated beads may break the bead or rim with explosive force sufficient to cause death or serious injury.
- After seating the beads, adjust the inflation pressure to the recommended operating pressure listed.
- **DO NOT** weld, braze, or otherwise attempt to repair or use a damaged rim.

## SCALE INDICATOR SETUP AND CALIBRATION

The setup and calibration numbers for the scale indicator will be set at the factory. If the scale indicator requires setting due to replacement or for another reason, the setup and calibration numbers for the unit are as follows. Refer to the information provided in the separate manual included with the electronic scale system for input instructions.

<u>Model</u>	<u>Setup</u>	<u>Calibration</u>
5205, 5305 & 5380	140640	032640

## INSTALLING BELT DISCHARGE TO TRAILER MIXER FEEDERS

1. Install the discharge support wing (1) and spacer (2) to the mounting brackets (3) on the mixer using bolts (4), flat washers (5), lock washers (6) and nuts (7). Fig. 12
2. Fit discharge into position under the tube. Install the connecting pin (8) through the discharge into the tube. Line up the hole in the discharge mount tube (9) with the hole in the connecting pin (8). Install the cotter pin (10). Spread the cotter pin apart. Fig. 12
3. Install bolts (4), flat washers (5), lock washers (6) and nuts (7) through the discharge side (1) and discharge (11) into one of the holes to get the height that you need. Fig. 12
4. Route the hydraulic hoses through the frame and hose bracket.

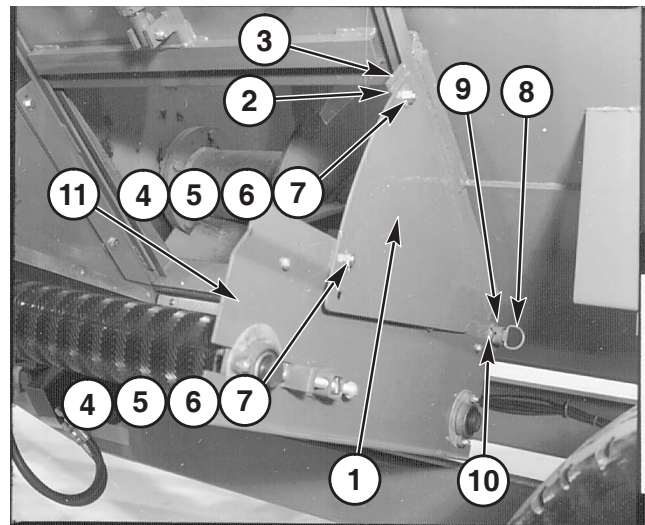

- 1 – Discharge Side
- 2 – Washer Spacer
- 3 – Mounting Brackets
- 4 – Bolt, Carriage 1/2-13 x 1" Grade 5
- 5 – Washer, Flat 1/2"
- 6 – Washer, Lock 1/2"
- 7 – Nut, Hex 1/2-13
- 8 – Pin Connecting
- 9 – Discharge Mount Tube
- 10 – Cotter Pin
- 11 – Discharge

Fig. 12

## CYLINDER MOUNT EXTENSION

The cylinder mount extension for the 5205 and the 5380 are mounted with the straight edge (6) down. For the 5305 the straight edge (6) is up as shown. Fig. 13

1. Install the hydraulic line (1) into port (2) of hydraulic cylinder (3). Install the hydraulic line (4) into port (5) of hydraulic cylinder (3). Fig. 13
2. Route the hydraulic hoses for the door cylinder through the frame and hose bracket.

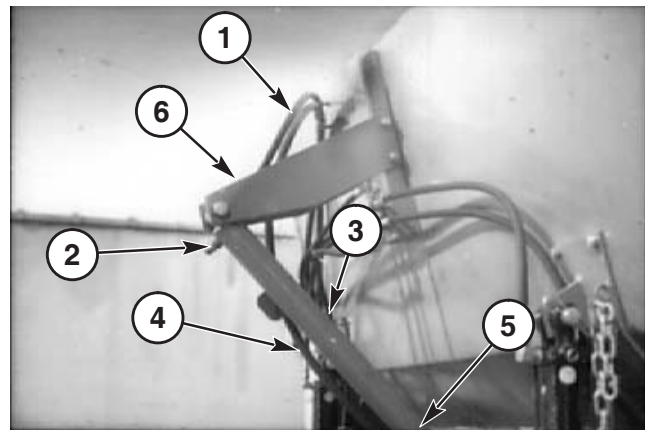

- 1 – Hydraulic Line
- 2 – Port, Hydraulic
- 3 – Hydraulic Cylinder
- 4 – Hydraulic Line
- 5 – Port, Hydraulic
- 6 – Cylinder Mount Extension Straight Edge Up

Fig. 13: 5305 Shown

## INSTALLING PRESSURE RELIEF KIT

1. Relieve hydraulic oil pressure in all lines by positioning the hydraulic flow controls on the tractor as required or as specified in the Operator's Manual.
2. Disconnect the hoses from the tractor to the hydraulic cylinder for the discharge door.
3. Disconnect the hoses from the hydraulic cylinder (1) and remove the 90° elbows (2). Fig. 14
4. Mark and drill two 9/32" holes in the extension arm at the locations shown in Fig. 17
5. Mount the pressure relief valve (3) to the extension arm (4) using bolts (5), washers (6) and nuts (7). Figs. 15 & 17
6. Install the hydraulic fittings and hoses as shown. Figs. 15 & 17
7. Install the hoses (8) from the tractor as shown. Fig. 16
8. Check the pressure relief valve setting. Remove the acorn nut (9) from the pressure relief valve. The threaded shaft should be backed out counter-clockwise. If it is not already backed out counter-clockwise, loosen the jam nut and back out the threaded shaft until almost fully loose but do not remove. Tighten the jam nut and reinstall the acorn nut.

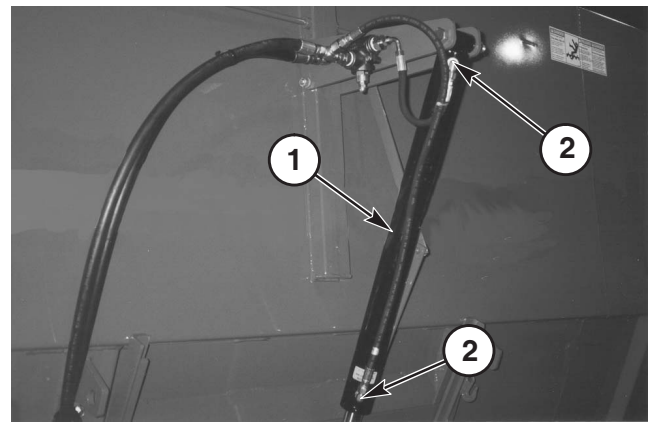

1 – Hydraulic Cylinder  
2 – 90° Elbow

Fig. 14

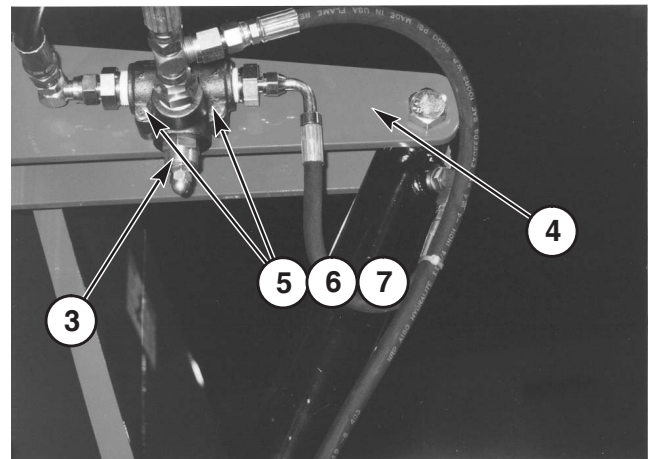

3 – Pressure Relief Valve  
4 – Extension Arm  
5 – Bolt, Hex 1/4-20 x 2"  
6 – Washer, Lock 1/4"  
7 – Nut, Hex 1/4-20

Fig. 15

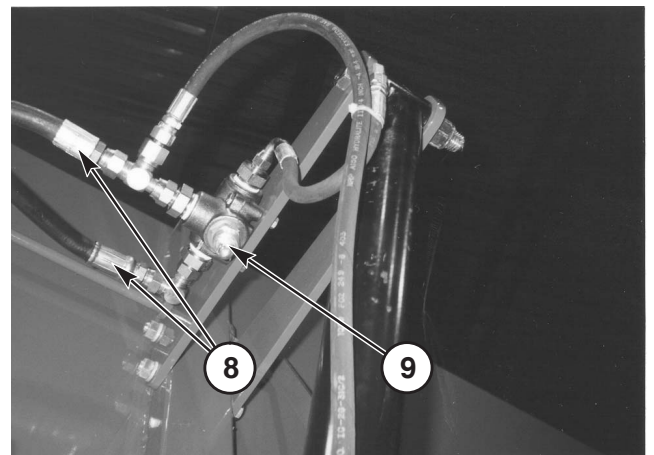

8 – Hoses From Tractor  
9 – Acorn Nut

Fig. 16

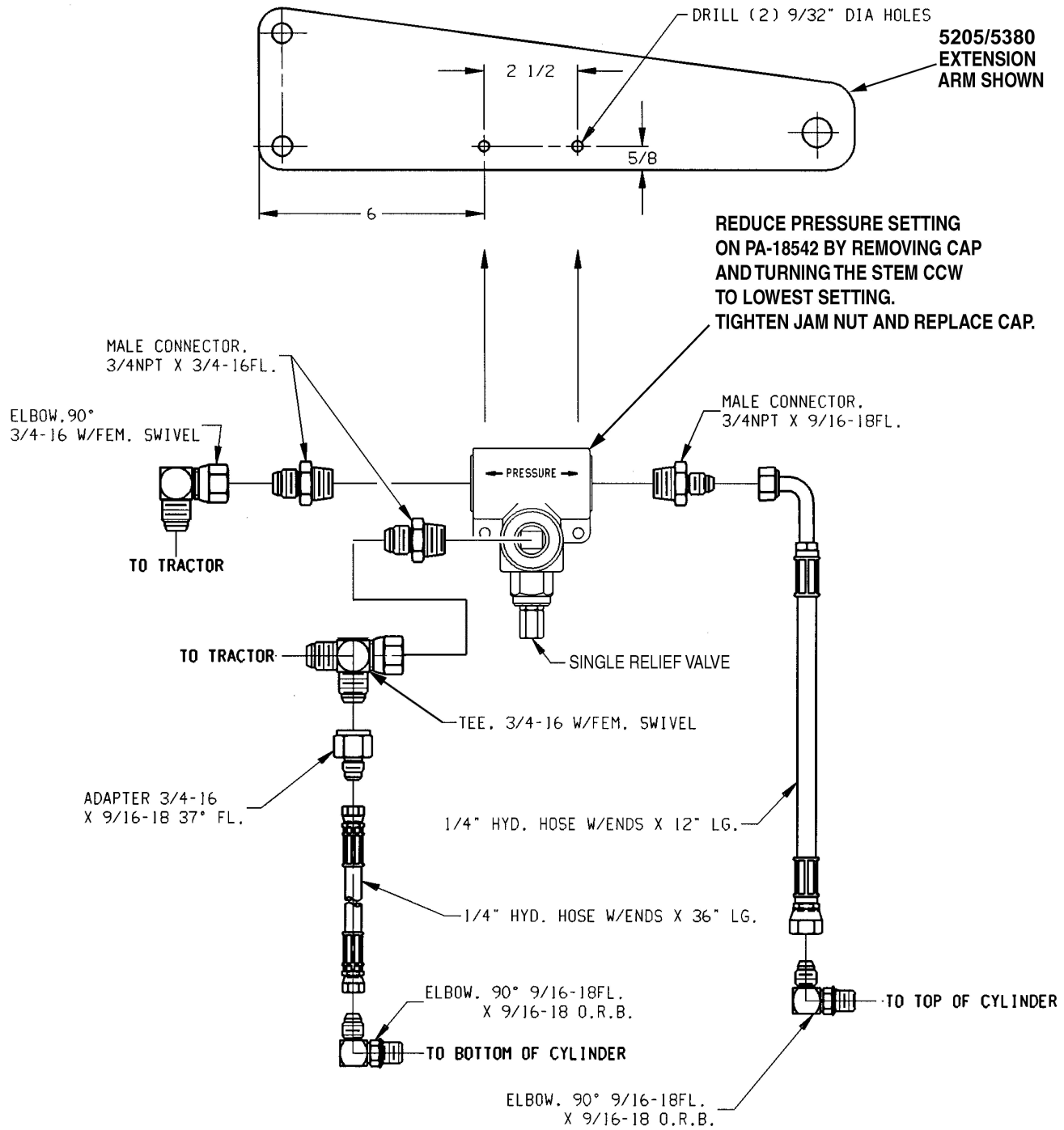

**Fig. 17: Pressure Relief Kit**



## INSTALLING HYDRAULIC HEIGHT CONTROL BELT DISCHARGE USED ON 48" AND 60" BELT DISCHARGE

**NOTE:** For component identification refer to Fig. 22 and the accompanying parts list.

1. Mark and drill four 13/32" holes at a length of 26-1/2" for the model 5205 unit and 19-3/4" for models 5305/5380 13/32" per Fig. 18. Install hydraulic lift base (2) to the discharge using bolts (9), lock washers (11) and nuts (30).

**NOTE:** Mark and drill four holes at a length of 26-1/2" for the model 5205 unit and 19-3/4" for models 5305/5380.

2. Mark and drill one 13/32" hole in each door rail 19-1/2" down from the top in each rail and 1-3/4" in from the edge to mount the side extension (28). See Fig. 19 for hole location. Mount the side extensions (28) at the existing top hole location using carriage bolts (31), spacers (34), flat washer (32), lock washers (33) and nuts (35). Mount the side extensions (28) at the bottom hole location using cap screws (29), spacers (27), lock washers (11) and nuts (30). Fig. 22

3. Connect chains (4) to the hydraulic lift base (2) using bolts (10) and lock nuts (12) and hook the chains to the hooks welded to the Mixer Feeder by the upper cylinder mounts. Fig. 20

4. Mount the cylinder (3) to the right mount with the top hose port facing out and the bottom port facing to the right side. Before mounting the left cylinder, disassemble the four nuts off from the bottom end of the four rods and turn the bottom hose port one half turn. Reassemble by tightening the 4 nuts evenly. Mount the cylinder (3) to the left mount with the top hose port facing out and the bottom port facing to the left side. Drill a 3/16" (4.76 mm) hole for mounting the cushioned loop clamps as shown. Install two cushioned loop clamps (16) on the hoses and secure using a self tapping screw (17) as shown. Fig. 20

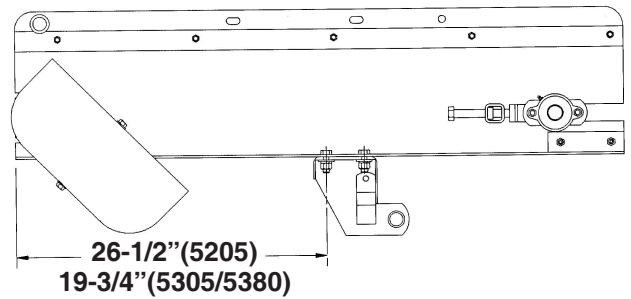

Fig. 18

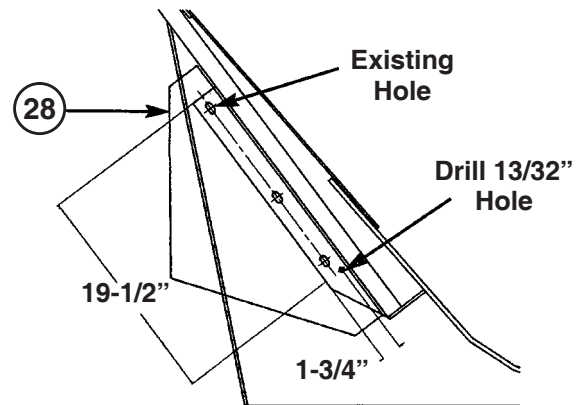

Fig. 19

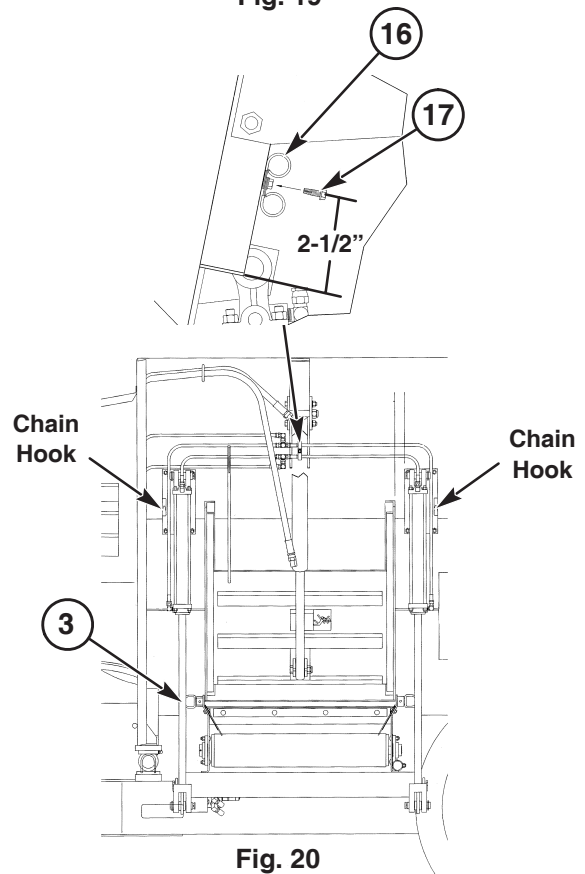

Fig. 20

- Install one 90° elbow (19) to the pressure reducing valve (1) in the top port closest to the relief valve before mounting to the mixer feeder. Install two adaptors (18) in the other two ports of the pressure reducing valve. Mount the pressure reducing valve (1) in the two existing holes in the front of the Mixer Feeder near the oil reservoir with the two hose ports up, serial plate out, using two bolts (13) and two center lock nuts (14). Connect four elbows (15) to the cylinder ports using liquid pipe sealant. Connect two 30" hoses (6) to the elbows in the top ports. Connect the 30" hoses together with a tee w/female swivel (20), passing the hose through the top cushioned loop (16). Connect an elbow (18) to the tee and connect a 60" hose (8) to the elbow. Connect the 60" hose from the top of cylinder ports to the adapter in the top of the pressure reducing valve furthest from the Mixer Feeder passing the hose through the hose holder next to the left cylinder bracket. Fig. 21

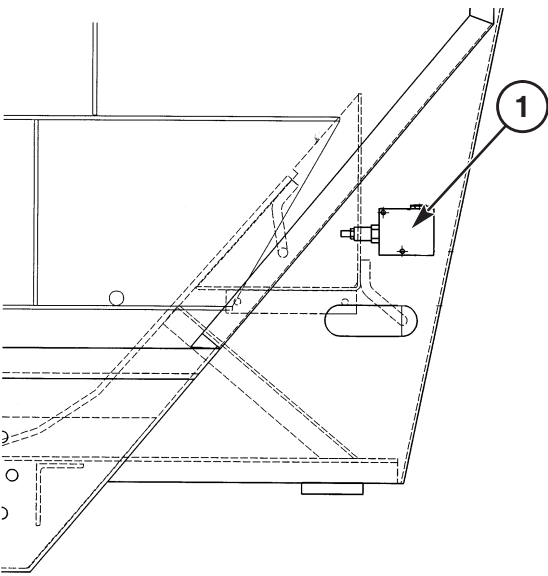
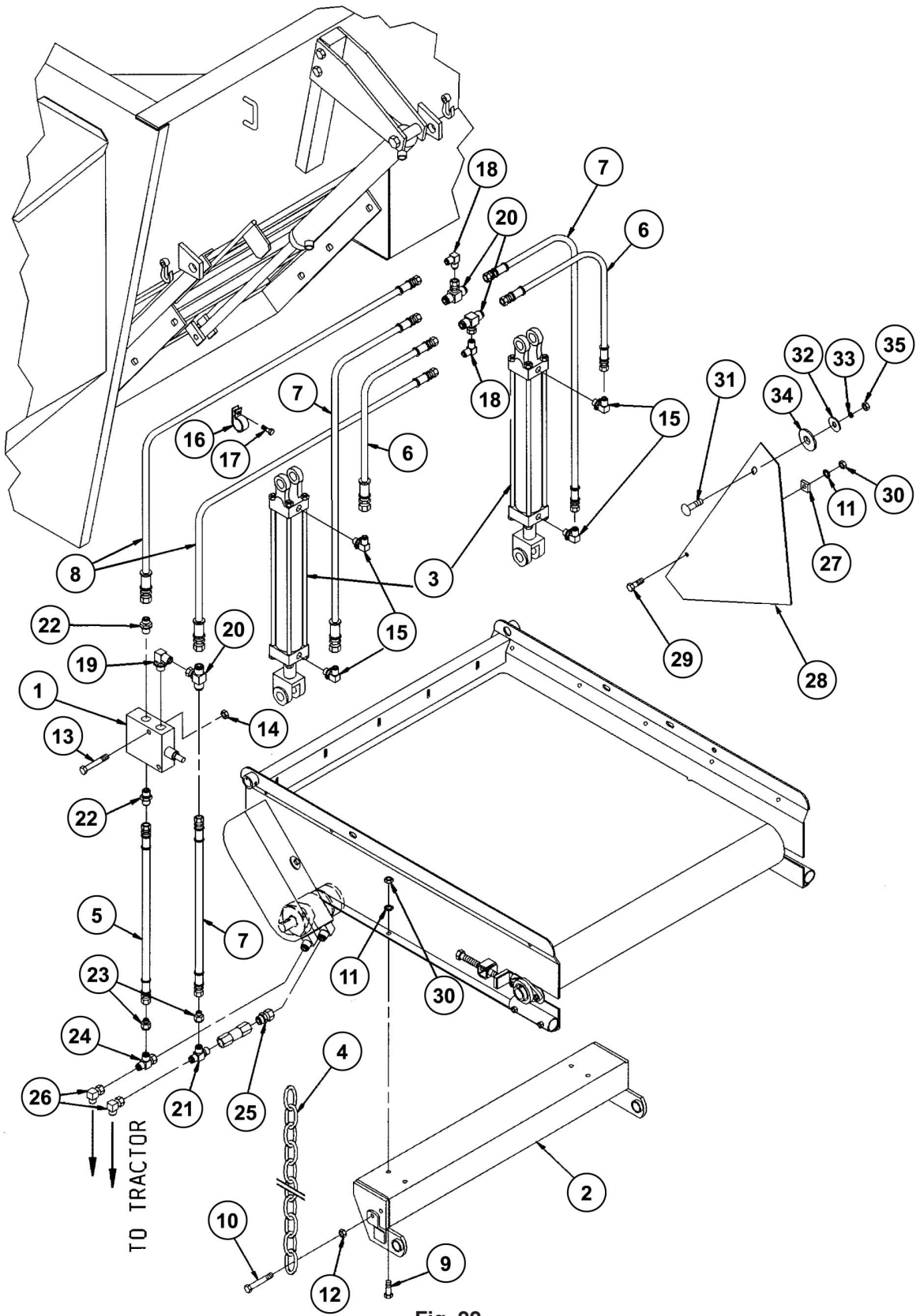

Fig. 21

- Connect two 48" hoses (7) to the elbows in the bottom cylinder ports. Connect the 48" hoses together with a tee (20) passing the hose through the bottom of the cushioned loop (16). Connect an elbow (18) to the tee and connect a 60" hose (8) to the elbow. Connect the end of the tee (20) to the top elbow closest to the discharge in the pressure reducing valve. Connect the 60" hose (8) to this tee in the pressure reducing valve also passing this hose through the hose holder next to the left cylinder bracket. Keeping these hoses behind the hoses from the top cylinder ports will keep the hoses away from interfering with opening the door. Nylon cable ties can also be used for this purpose.
- Remove the two hoses from the hydraulic motor. On the top port elbow, install a swivel adapter (25). Remove the check valve and nipple from the end of the hose that goes to the tractor and install the check valve on the adaptor from the top port of the hydraulic motor with the arrow in/out direction for flow. Discard the nipple. Install the end of the tee (21) in the the check valve. Install the adapter (23) into the side of the tee. Install the elbow (26) into the other end of the tee. Install the hose to the tractor into this elbow. Next install a 48" hose (7) into the adapter in the tee. This hose connects into the tee on the pressure reducing valve.
- Install the end of tee (24) into the elbow on the bottom port of the hydraulic motor. Install the adapter (23) into the side of the tee. Install the elbow (26) into the other end of the tee. The hose to the tractor is connected to this elbow. Next install a 42" hose (5) to the adapter in the tee. This hose connects to the bottom adapter from the pressure reducing valve.



Ref. No.	Part No.	Description	Qty. Req.	Ref. No.	Part No.	Description	Qty. Req.
	167786	HYDRAULIC HEIGHT CONTROL	AR	18	167260	90° ELBOW 9/16 FLARE	2
1	167401	PRESSURE REDUCING VALVE	1	19	068938	90° ELBOW 9/16-18 W/ADJ. ORB.	1
2	167329	HYDRAULIC LIFT BASE	1	20	095457	TEE 9/16 W/FEMALE SWIVEL	3
3	167328	HYD. CYLINDER 2" BORE 16" STROKE	2	21	167307	TEE 3/4-16 W/ADJ. O.R.B. ON RUN	1
4	167247	CHAIN	2	22	167237	ADAPTER 9/16" O-RING W/9/16" FLARE	2
5	167096	1/4" HYD. HOSE W/ENDS X 42"	1	23	167236	ADAPTER 3/4-16 9/16-18 (37°)	2
6	167991	1/4" HYD. HOSE W/ENDS X 30"	2	24	076143	TEE 3/4-16 W/FEM. SWIVEL	1
7	167076	1/4" HYD. HOSE W/ENDS X 48"	3	25	167306	SWIVEL ADAP. 3/4 FL. 3/4 O-RING	1
8	167059	1/4" HYD. HOSE W/ENDS X 60"	2	26	088442	90° ELBOW 3/4-16 W/FEM. SWIVEL	2
9	650490	CS 3/8 X 1	4	27	058876	SPACER	2
10	167253	CS 3/8 X 2-1/4	2	28	167330	SIDE EXTENSION	2
11	654026	LW 3/8	6	29	166934	HTB 3/8 X 1-1/4	2
12	067847	HLN-INS 3/8	2	30	653010	HN 3/8	6
13	650419	CS 1/4 X 1-3/4	2	31	650834	CB 1/2 X 1-1/2	2
14	071700	LN 1/4	2	32	654009	FW 1/2	2
15	057650	90° ELBOW 3/8 NPT MALE 9/16 FLARE MALE	4	33	654030	LW 1/2	2
16	167235	7/8" DIA. CUSHIONED LOOP CLAMP	2	34	054042	WASHER, PLAIN 5/8 STD.	2
17	651602	SELF TAPPING SCREW 1/4 X 1/2	1	35	653018	HN 1/2	2



## INSTALLING AUGER DISCHARGE

1. Fit the discharge into position under the tube. Install the connecting pin (1) through discharge into the tube. Line up the hole in the discharge bracket (2) with the hole in the connecting pin (1). Install the cotter pin (3) and spread the cotter pin apart. Fig. 23
2. The discharge side (4) appear different for each size of mixer and length of discharge. Fig. 23
3. Install the discharge side (4) and spacer (5) to mounting brackets (6) on the mixer using bolts (7), flat washer (8), lock washer (9) and nut (10). Fig. 23
4. Install bolt (7), flat washer (8), lock washer (9), and nut (10) through discharge side (4) and discharge (11). Fig. 23
5. Refer to Page 14 for connecting the auger discharge hydraulics to the Mixer Feeders.

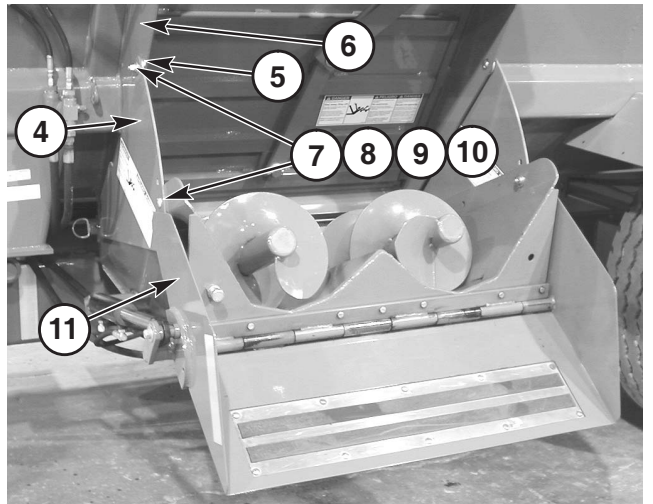
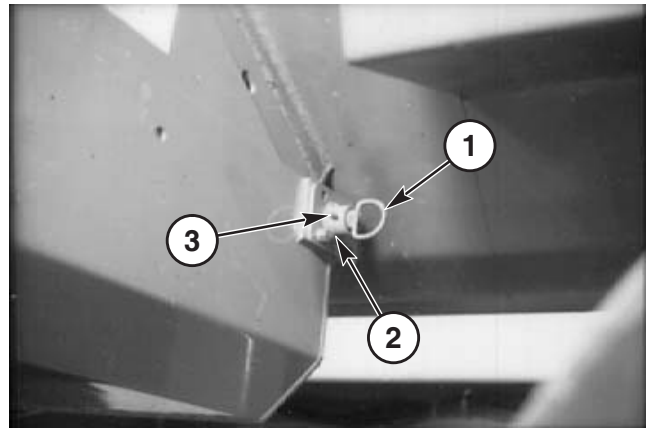

- 1 – Connecting Pin
- 2 – Discharge Bracket
- 3 – Cotter Pin
- 4 – Discharge Side
- 5 – Spacer Washer
- 6 – Mounting Brackets
- 7 – Bolt, Carriage 1/2–13 x 1-1/4" Grade 5
- 8 – Washer, Flat 1/2"
- 9 – Washer, Lock 1/2"
- 10 – Nut, Hex Lock 1/2–13
- 11 – Discharge

Fig. 23

## HOOKING UP THE HYDRAULICS TO THE AUGER DISCHARGE

1. Install tractor hydraulic line (1) into port (2) of hydraulic motor (3). Install tractor hydraulic line (4) into port (5) of hydraulic motor (3). Fig. 24

**NOTE:** Tee on hydraulic motor (3) has a check valve (9) installed.

2. Install hydraulic line (6) of discharge drop chute cylinder (7) into tee of hydraulic line (1). Install hydraulic line (8) of cylinder into tee of hydraulic line (4). Fig. 24

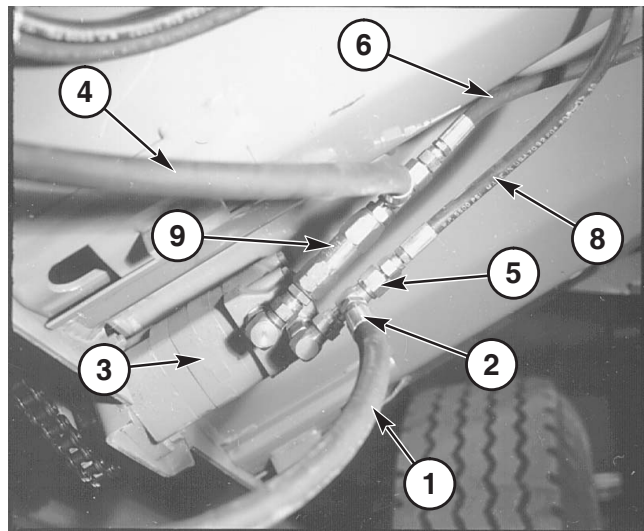
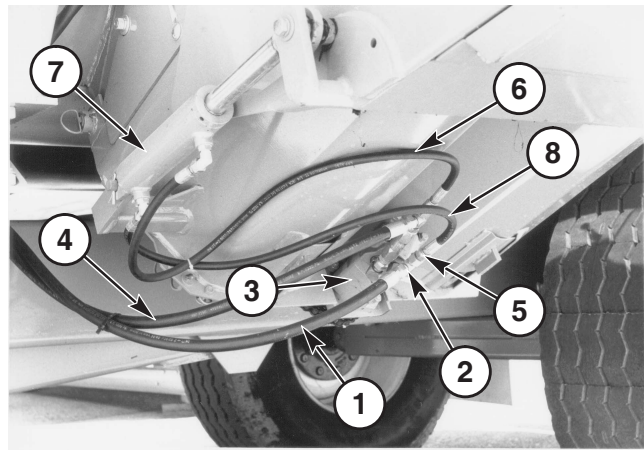

- 1 – Hydraulic Line
- 2 – Port, Hydraulic
- 3 – Hydraulic Motor
- 4 – Hydraulic Line
- 5 – Port, Hydraulic
- 6 – Hydraulic Line
- 7 – Cylinder, Discharge Drop Chute
- 8 – Hydraulic Line
- 9 – Check Valve

Fig. 24

## INDICATOR EXTENSION ARM

1. Remove bolt (1) holding electronic scale indicator (2) to indicator mount (3). Remove electronic scale indicator. Fig. 25
2. Mount indicator extension arm (4) to scale indicator mount (3) using bolt (1) and lock nut (5) with indicator bar cushions (6) on top and bottom of the indicator extension arm. Fig. 25
3. Mount the electronic scale indicator to the indicator extension arm (4) using bolt (1) and lock nut (5) with bar cushions (6) on top and bottom of the indicator extension arm. Fig. 25

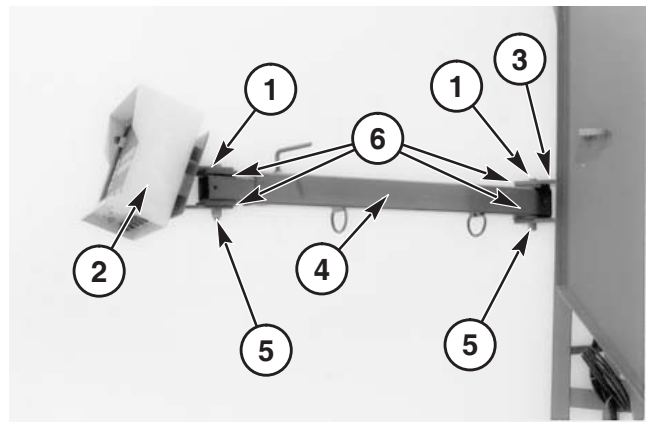

- 1 – Bolt, Hex 1/2–13 x 4
- 2 – Electronic Scale Indicator
- 3 – Indicator Mount
- 4 – Indicator Extension Arm
- 5 – Nut, Nylon Lock 1/2–13
- 6 – Bar Cushion

Fig. 25

## BUMPER

1. Attach the bumper (1) to the trailer frame (2) with four bolts (3) and nylon locknuts (4). Fig. 26

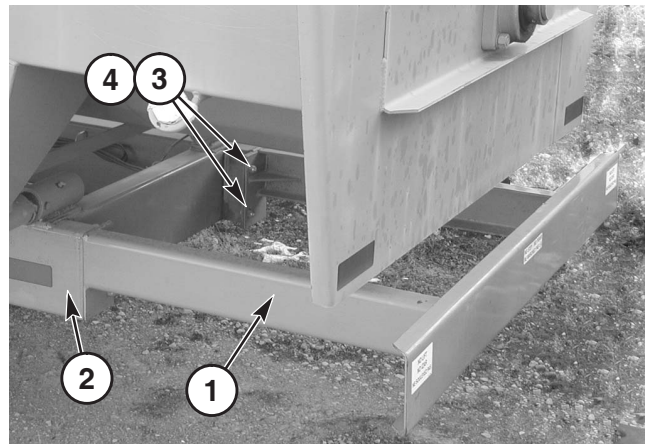

- 1 – Bumper
- 2 – Trailer Frame
- 3 – Bolt, Hex 1/2–13 x 1-1/4"
- 4 – Nut, Nylon Lock 1/2–13

Fig. 26

# **GEHL**®

**Gehl Company** 143 Water Street, P.O. Box 179, West Bend, WI 53095-0179 U.S.A.  
([www.gehl.com](http://www.gehl.com))