



Dealer Set-up Instructions for 5000 Series Mixer Feeders

These instructions provide details for unpacking and setting up a 5450, 5510, 5575, 5750 or 5950 Mixer Feeder. They should be retained by the dealer.

GENERAL INFORMATION

5000 Series Mixer Feeders are shipped in varying stages of disassembly.

Unless otherwise noted, the standard fastening procedure is to secure two parts with a cap screw, lock washer and nut. A part with a mounting slot should be secured with a plain washer against the slotted surfaces. Lock nuts are sometimes used to prevent two parts from separating but still allow one part to move or rotate next to the other. Attaching hardware, if it will require installation in the path of material flow, should always be installed with the head of the screw on the same side of the part that will be in contact with the material.

TRAILER MODELS

1. Install plug (1) in the threaded hole on the underside of the rear drive compartment (2). Use sealant on the threads. Fig. 1

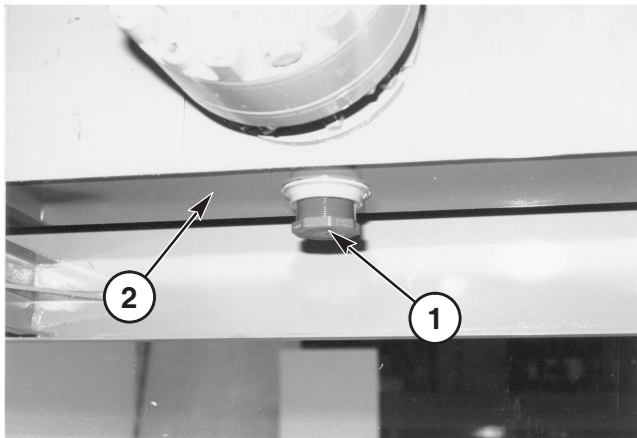

1 – Plug
2 – Rear drive compartment
Fig. 1

2. Open the rear drive compartment doors and add SAE 30W motor oil until it reaches the chain of the lower drive sprocket as shown. Rear drive compartment oil capacity is approximately 16 gallons U.S. (61 L). Fig. 2

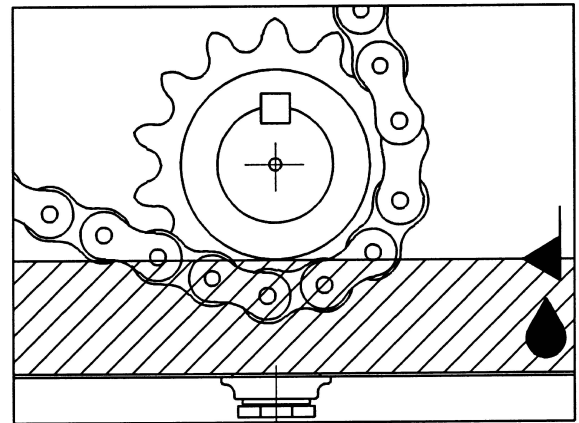
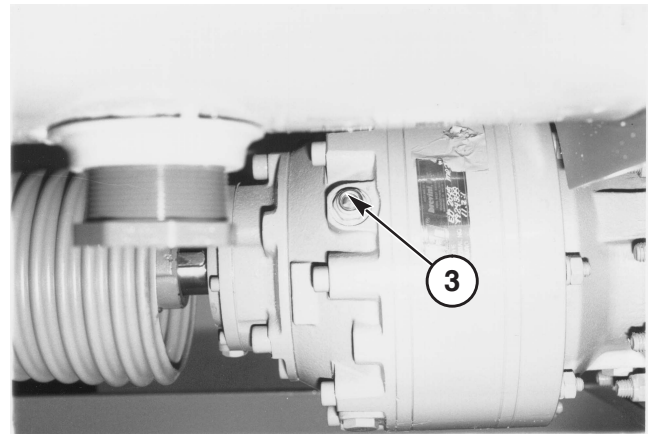

Fig. 2

3. Check the oil level in the planetary gearbox using the sight gauge (3) on the left side of the gearbox. Fig. 3



3 – Sight gauge

Fig. 3

4. Install two plugs (4) in the threaded holes on the rear underside of the mixing chamber (5). Fig. 4

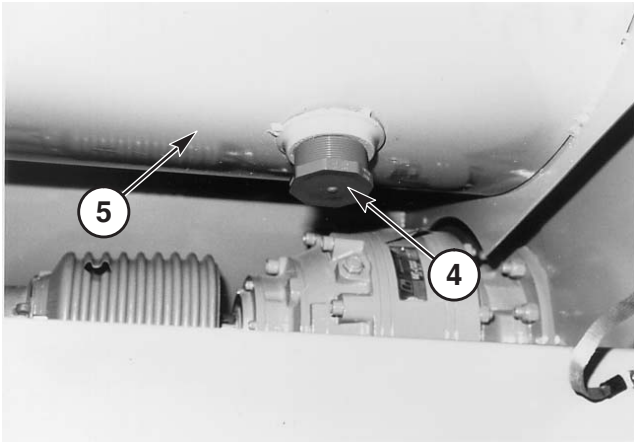

4 – Plug
5 – Mixing chamber

Fig. 4

5. Install the PTO shaft (6) on the drive shaft (7) with the key (8) in place. Tighten the setscrews (9). Hook the PTO safety chain (10) onto the trailer tongue (11). Fig. 5

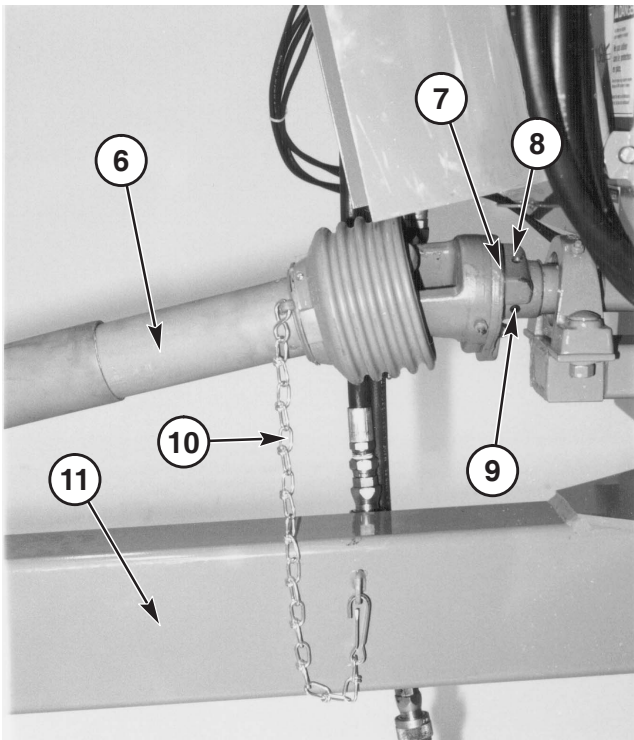

6 – PTO shaft
7 – Drive shaft
8 – Key
9 – Setscrews
10 – PTO Safety Chain
11 – Trailer Tongue

Fig. 5

6. Check for proper assembly, adjustment and lubrication. Check all bolts and setscrews and tighten as needed.
7. Be sure all shields are properly in place.
8. Check for and remove any foreign objects and tools in the mixing chamber, discharge chute, and oil bath reservoir area.

WARNING

Before attaching the Mixer Feeder to the tractor, be sure the tractor brakes are in good working condition.

Use the proper tractor for handling a loaded Mixer Feeder. The table below gives the acceptable transport speed for the ratio the machine gross weight.

<u>Loaded Mixer Weight</u>	<u>vs. Tractor Weight</u>	<u>Maximum Speed</u>
1:1 or less		20 mph (32 km/h)
Between 2:1 and 1:1		10 mph (16 km/h)
More than 2:1		Do not tow

NOTE: See the Specifications section in the Operator's Manual for the weight of your Mixer Feeder.

9. Tractor drawbar (16) pin hole centerline must be 14" from the end of the tractor PTO shaft (12) for the 540 RPM units and 16" for the 1000 RPM units for correct adjustment. Fig. 6

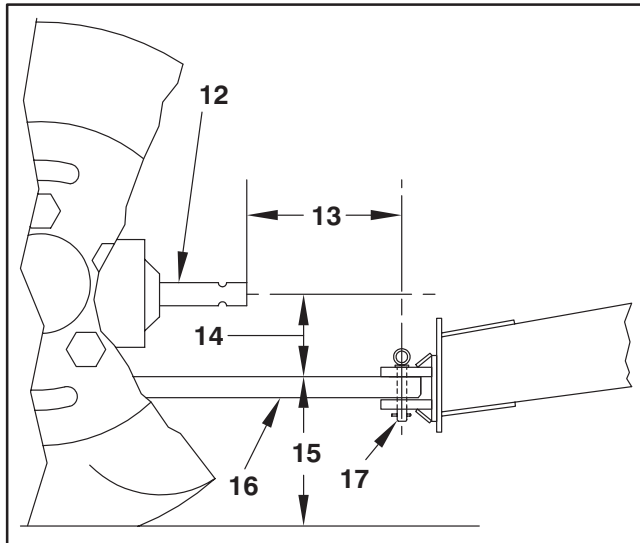

- 12 – Tractor PTO Shaft (Tractor MUST comply with ASAE Standard S203)
- 13 – 14" (356 mm) for 540 RPM or 16" (406 mm) for 1000 RPM
- 14 – 8 to 13" (203 to 330 mm) - 10" (254 mm) Standard
- 15 – 13 to 22" (330 to 559 mm)
- 16 – Tractor Drawbar
- 17 – Locking Hitchpin

Fig. 6

10. The hitch (18) may need to be adjusted up or down to obtain a level Mixer Feeder. Use the hitch jack to level the Mixer Feeder. Remove the nuts, lock washers and bolts, then move the hitch jaw up or down and reinstall the nuts, lock washers and bolts. Fig. 7



18 – Mixer hitch

Fig. 7

11. For the standard hitch, locate the tractor drawbar (19) between the hitch (20), and install the locking hitch pin (22). For the pinto hitch, locate the pinto hitch (21) between the top plate, V-block and cushion and install the locking hitch pin (22). Fig. 8

NOTE: The pinto hitch shown does not have the bottom clevis part of the hitch attached. Instead the pinto hitch has a top plate, V-block, and cushion.

12. Install the safety chain (23). See the tractor Operator's Manual for recommendations. Fig. 8

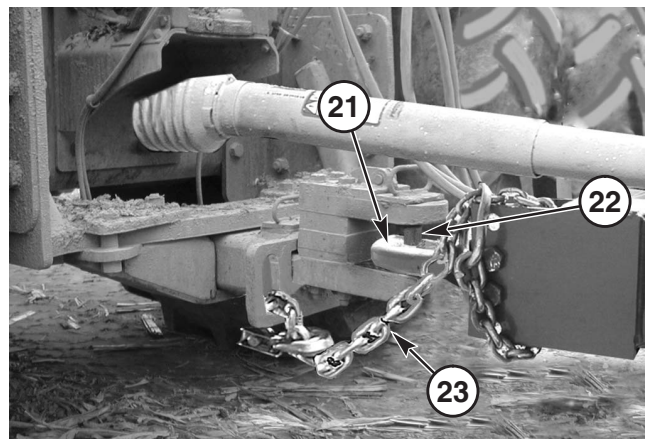
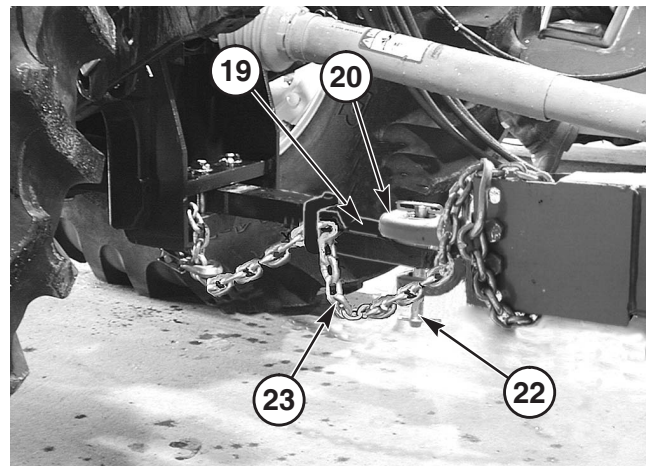

- 19 – Tractor drawbar
- 20 – Mixer hitch
- 21 – Pinto hitch
- 22 – Locking hitch pin
- 23 – Safety chain

Fig. 8

13. Remove the hitch jack and store it in the hitch jack holder and secure it in place by inserting the locking pin.

- Slide the locking collar (24) back while pushing the PTO shaft (25) onto the tractor PTO shaft (26). The PTO shaft is in position when the locking collar snaps forward into place. Fig. 9

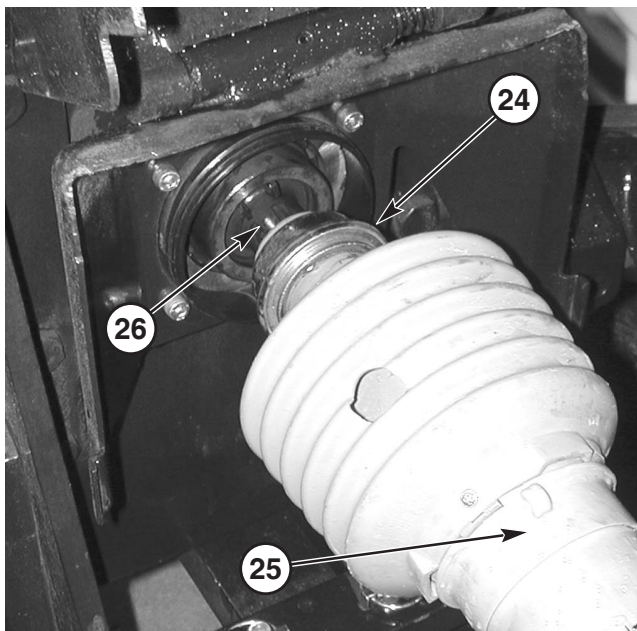

24 – Locking collar
25 – PTO Shaft
26 – Tractor PTO Shaft

Fig. 9

- Wipe off the hose couplings and tractor couplings with a clean cloth, and install the hydraulic hoses (27) to the couplings (28) on the tractor. Fig. 10
- Test run the unit and check for proper hydraulic functions. The discharge door should go up and down and the discharge conveyor should turn on and off.
- Remove the electrical seven-pin male connector (29) from the holder on the Mixer Feeder by pushing the connector in and turning it 90°, then pull it out. Install the electrical seven-pin male connector to the tractor. Fig. 10

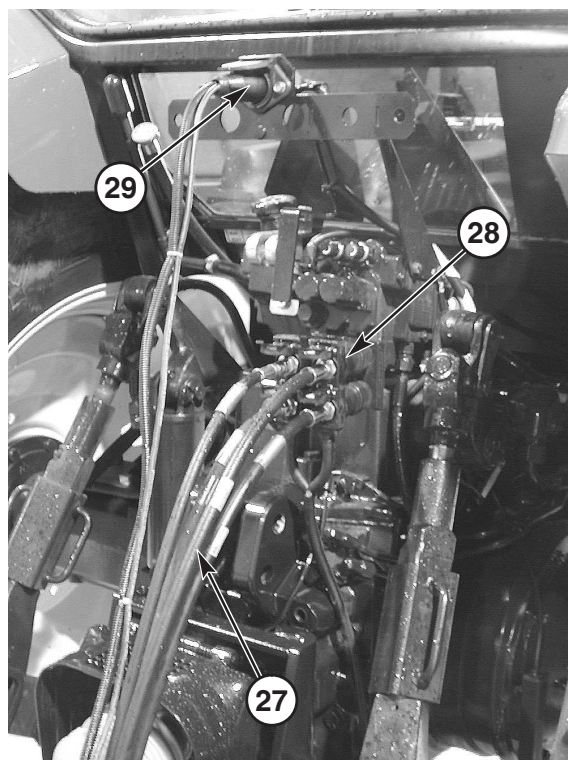

27 – Hydraulic hoses
28 – Tractor hydraulic couplings
29 – 7-Pin electrical male connector

Fig. 10

- Check the lights for function. The lights, turn signals, brake lights and the flashing warning lights should work with the tractor's lights.



WARNING

ALWAYS follow state and local regulations regarding the use of safety chain and auxiliary lighting when towing farm equipment on public highways. **ONLY** a safety chain (NOT an elastic or a nylon/plastic tow strap) should be used to retain the connection between the towing and towed machines, in the event of separation of the primary attaching system. **BE SURE** to check with local law enforcement agencies for your own particular regulations. Never tow a mixer on a public highway at a speed greater than 20 mph (32 km/h).

IMPORTANT: The maximum angle of the wide-angle PTO joint must not exceed 80° under any condition of the driveline. Larger angles will result in joint damage. In continuous operation, an angle of 35° must not be exceeded.

19. These maximum joint angles must be observed or serious injury and damage could occur. Fig. 11
Continuous operation – 35 Degrees
Non-rotating – 80 Degrees

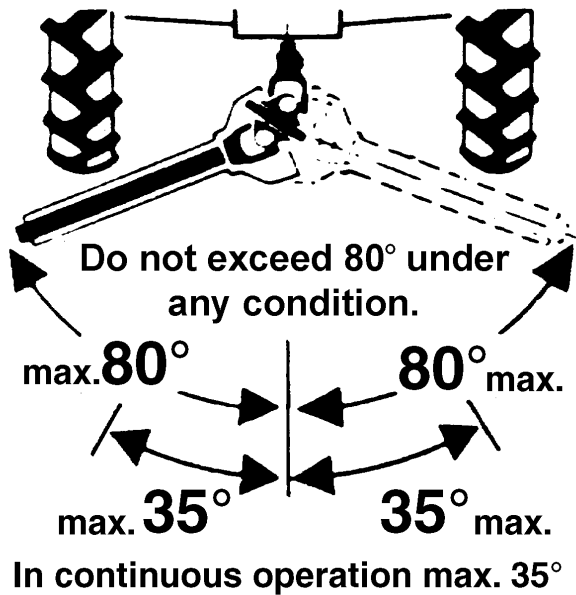

Fig. 11

20. Test run the unit and check for proper hydraulic action.

IMPORTANT: Be sure the tractor PTO rotation is correct. Running the PTO in the opposite direction will cause damage. Correct rotation is clockwise when facing in the direction of forward travel.

TIRES AND WHEELS

Tires & Wheels

Check the Mixer Feeder tire pressure after every 50 hours of operation. Tires should be inflated to the appropriate pressure listed in the table. Wheel lug torque should be checked after every 50 hours of operation and tightened with 275–285 ft-lb (373–386 Nm) torque for the 10-Bolt wheels.

Table of Tire Pressures

Tire Size & Style	Inflation Pressures	
	PSI	kPa
16.50 x 22.5 Radial Recap Truck Tire on 13:00 x 22.5 10-Bolt Rim	85	586
18.00 x 22.5 Radial Recap Truck Tire on 13:00 x 22.5 10-Bolt Rim	85	586
44 x 16 Used Aircraft Tires	85	586
49 x 17 Used Aircraft Tires	85	586



WARNING

Tire mounting, repairing and replacing should **ONLY** be performed by a qualified tire manufacturer's representative, or by properly trained personnel following the tire manufacturer's instructions. If you do not have such instructions, contact your tire dealer or our Company.



WARNING

Inflating or servicing tires can be dangerous. Whenever possible, trained personnel should be called to service and mount tires. To avoid possible death or serious injury, follow the safety precautions below:

- **BE SURE** the rim is clean and free of rust.
- Lubricate both the tire beads and rim flanges with a soap solution. **DO NOT** use oil or grease.
- Use a clip-on tire chuck with a remote hose and gauge, which allows you to stand clear of the tire while inflating it.
- **DO NOT** place your fingers on the tire bead or rim during inflation.
- **NEVER** inflate beyond 35 PSI (240 kPa) to seat the beads. If the beads have not seated by the time the pressure reaches 35 PSI, deflate the assembly, reposition the tire on the rim, relubricate both parts and re-inflate it. Inflation pressures beyond 35 PSI with unseated beads may break the bead or rim with explosive force sufficient to cause death or serious injury.
- After seating the beads, adjust the inflation pressure to the recommended operating pressure listed.
- **DO NOT** weld, braze, or otherwise attempt to repair or use a damaged rim.

INSTALLING BELT DISCHARGE TO TRAILER AND TRUCK MIXER FEEDERS

MODELS 5450, 5510, 5575, 5750

1. Install the discharge support wing (1) and spacer (2) to the mounting brackets (3) on the mixer using bolts (4), flat washers (5), lock washers (6) and nuts (7). Fig. 12
2. Fit discharge into position under the tube. Install the connecting pin (8) through the discharge into the tube. Line up the hole in the discharge bracket (9) with the hole in the connecting pin (8). Install the cotter pin (10). Spread the cotter pin apart.
3. Install bolts (11), flat washers (5), lock washers (6) and nuts (7) through the discharge supporting wing (1) and discharge (12) into one of the four holes to get the height that you need. Fig. 12

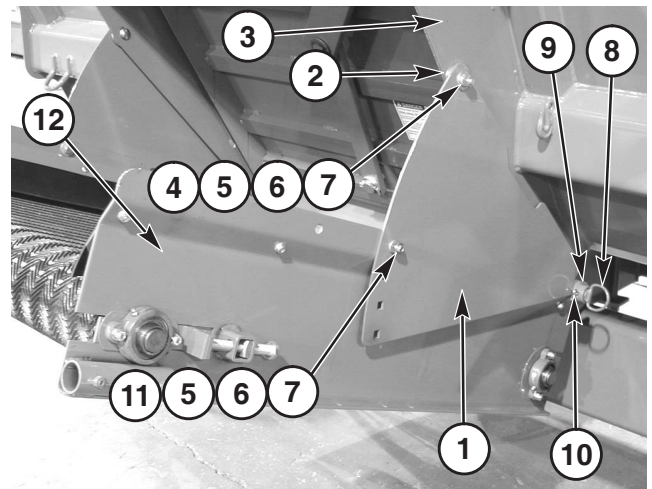

- 1 – Discharge Support Wing
- 2 – Washer Spacer
- 3 – Mounting Brackets
- 4 – Bolt, Carriage 1/2–13 x 1-1/2” Grade 5
- 5 – Washer, Flat 1/2”
- 6 – Washer, Lock 1/2”
- 7 – Nut, Hex 1/2–13
- 8 – Pin Connecting
- 9 – Bracket Discharge
- 10 – Cotter Pin
- 11 – Bolt, Hex 1/2–13 x 1-1/4” Grade 5
- 12 – Discharge

Fig. 12

INSTALLING HYDRAULIC HEIGHT CONTROL BELT DISCHARGE USED ON 48" AND 60" BELT DISCHARGE

1. Install the hydraulic lift base (1) to the discharge. Install bolt (2), plain washer (3), lock washers (4) and nuts (5). Fig. 13

NOTE: Discard the support wings from the belt discharge when using the hydraulic height control.

2. Fit discharge into position under the tube. Install the connecting pin (6) through the discharge into the tube. Line up the hole in the discharge mount tube with the hole in the connecting pin (6). Install the cotter pin (7). Spread the cotter pin apart. Mount the side extensions (8) and spacers (9) with the bolt (10), lock washer (13), and nut (14) to the mounting brackets on the Mixer Feeder. Connect the chains to the hydraulic lift base (1) with two bolts (11) and lock nuts (12) and hook the chains to the hooks welded to the Mixer Feeder. Fig. 13

3. Mount the cylinder (17) to the right mount with the top hose port facing out and the bottom port facing to the right side. Before mounting the left cylinder, disassemble the four nuts off from the bottom end of the four rods and turn the bottom hose port one half turn. Reassemble by tightening the 4 nuts evenly. Mount the cylinder (17) to the left mount with the top hose port facing out and the bottom port facing to the left side. Drill a 3/16" (4.76 mm) hole for mounting the cushioned loop clamps as shown. Install two cushioned loop clamps (16) on the hoses and secure using a self tapping screw (15) as shown. Fig.13

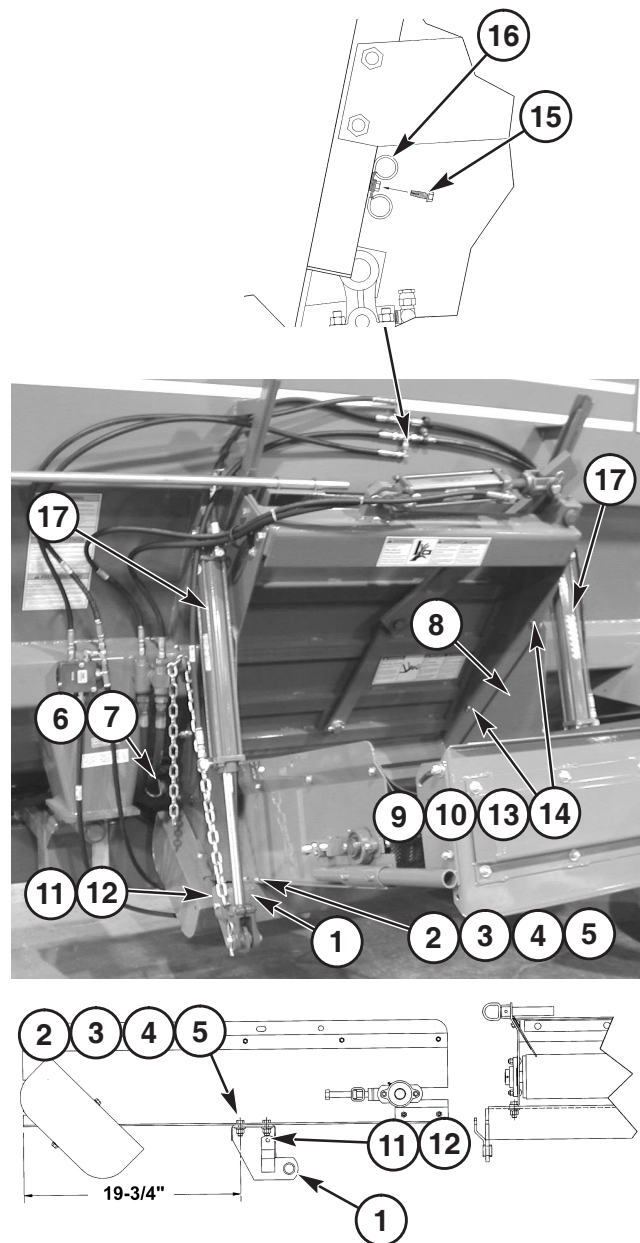

- 1 – Hydraulic Lift Base
- 2 – Bolt, Hex Head 3/8–16 x 1”
- 3 – Washer, Plain 3/8”
- 4 – Washer, Lock 3/8”
- 5 – Nut, Hex 3/8–16
- 6 – Pin Connecting
- 7 – Cotter Pin
- 8 – Side Extension
- 9 – Spacer
- 10 – Bolt, Carriage 1/2–13 x 1-1/2” Grade 5
- 11 – Bolt, Hex 3/8–16 x 2-1/4” Grade 5
- 12 – Nut, Nylon Lock 3/8–16
- 13 – Washer, Plain 1/2”
- 14 – Nut, Hex 1/2–13
- 15 – Self Tapping Screw 1/4–20 x 3/4”
- 16 – Cushioned Loop Clamps
- 17 – Hydraulic Cylinder

Fig. 13

- Install one 90° elbow (32) to the pressure reducing valve (33) in the top port closest to the relief valve before mounting to the mixer feeder. Install two adaptors (18) in the other two ports of the pressure reducing valve. Mount the pressure reducing valve (33) with the two hose ports up, serial plate out, with two bolts (19) by drilling and tapping with a 1/4–20 tap. Connect four elbows (20) to the cylinder ports using liquid pipe sealant. Connect two 30” hoses (21) to the elbows in the top ports. Connect the 30” hoses together with a tee w/female swivel (22), passing the hose through the top cushioned loop (16). Connect an elbow (23) to the tee and connect a 60” hose (24) to the elbow. Connect the 60” hose from the top of cylinder ports to the adapter in the top of the pressure reducing valve furthest from the discharge. Fig. 14

- Connect two 48” hoses (25) to the elbows in the bottom cylinder ports. Connect the 48” hoses together with a tee (22) passing the hose through the bottom of the cushioned loop (16). Connect an elbow (23) to the tee and connect a 60” hose (24) to the elbow. Connect the end of the tee (22) to the top elbow closest to the discharge in the pressure reducing valve. Connect the 60” hose (24) to this tee in the pressure reducing valve. Keeping these hoses behind the hoses from the top cylinder ports will keep the hoses away from interfering with opening the door. Nylon cable ties can also be used for this purpose. Fig. 14

- Remove the two hoses from the hydraulic motor. On the top port elbow, install a swivel adapter (26). Remove the check valve and nipple from the end of the hose that goes to the tractor and install the check valve on the adaptor from the top port of the hydraulic motor with the arrow in/out direction for flow. Discard the nipple. Install the side of the tee (27) in the the check valve. Install the adapter (28) into the end of the tee. Install the elbow (29) into the side of the tee. Install the hose to the tractor into this elbow. Next install a 48” hose (25) into the adapter in the tee. This hose connects into the tee on the pressure reducing valve. Fig. 14

- On the bottom port of the hydraulic motor, install the side of tee (30) into the elbow. Install the adapter (28) into the end of the tee. Install the elbow (29) into the side of the tee. The hose to the tractor is connected to this elbow. Next install a

42” hose (31) to the adapter in the tee. This hose connects to the bottom adapter from the pressure reducing valve. Fig. 14

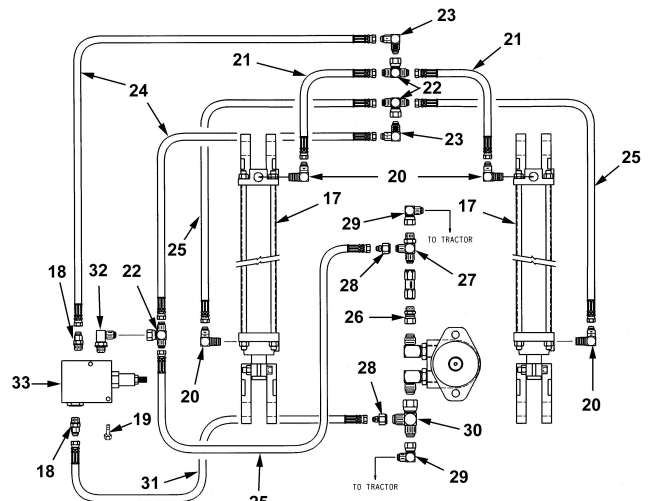
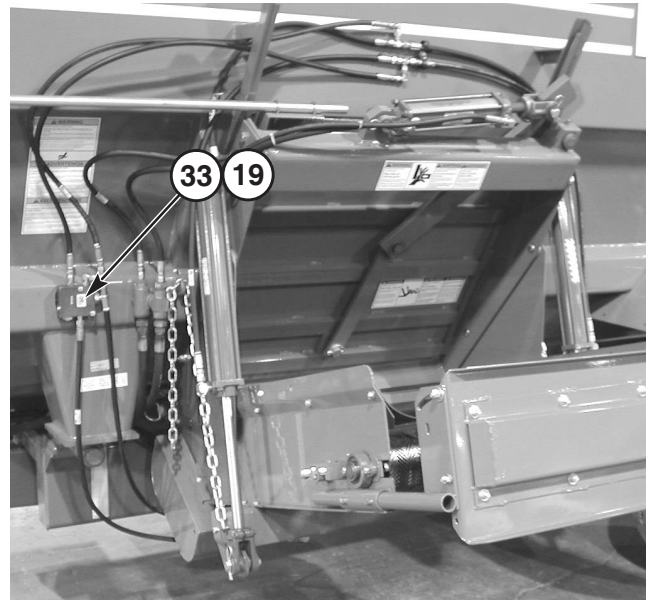

- 15 – Self Tapping Screw 1/4–20 x 3/4”
- 16 – Cushioned Loop Clamps
- 17 – Hydraulic Cylinder
- 18 – Adapter 9/16” O-Ring w/9/16” Flare
- 19 – Bolt, Hex Head 1/4–20 x 1-3/4”
- 20 – Elbow 90° 3/8 NPT Male 9/16 Fl. Male
- 21 – Hydraulic Hose 1/4” w/Ends 30”
- 22 – Tee 9/16” w/Female Swivel
- 23 – Elbow 90° 9/16” Flare
- 24 – Hydraulic Hose 1/4” w/Ends 60”
- 25 – Hydraulic Hose 1/4” w/Ends 48”
- 26 – Swivel Adapter 3/4 Fl. 3/4 O-Ring
- 27 – Tee 3/4–16 w/Adj. ORB
- 28 – Adapter 3/4–16, 9/16–18
- 29 – Elbow 90° 3/4–16 w/Female Swivel
- 30 – Tee 3/4–16 w/Female Swivel
- 31 – Hydraulic Hose 1/4” w/Ends 42”
- 32 – Elbow 90° 9/16–18 w/Adj. ORB
- 33 – Pressure Reducing Valve

Fig. 14

INSTALLING AUGER DISCHARGE ON 5950 MIXER FEEDERS (Trailer/Truck)

1. Fit the discharge into position under the tube. Install the connecting pin (1) through discharge into the tube. Line up the hole in the discharge bracket (2) with the hole in the connecting pin (1). Install the cotter pin (3) and spread the cotter pin apart. Fig. 15
2. Mount the two hydraulic cylinders (4) to the mixer and cylinder mounts on the discharge. Mount the inner pivot bars (5) with bushings (6), pivot bars (7), bolts (8), washers (9), and nut (10) to the mixer. Mount the pivot bars (7) to the top hole with bolts (11) and nuts (10). Mount the outer pivot bars (12) with bushings (13), bolts (11), washers (9) and nuts (10) to the flipper pan. Fig. 15

NOTE: Install one or two washers (9) between the outer pivot bar and the flipper pan so the wing clears the inner pivot bar Fig. 15.

3. Install two carriage bolts (14), washers (15), and nut (16) to connect the outer and inner bars. The bars are slotted to adjust the flipper pan. Fig. 15
4. Apply liquid pipe sealant to the four elbows (17) that screw into the cylinder ports and install facing up. Connect hoses (18) to the cylinder port bottom elbows. Connect hoses (19) to the elbows in the top ports. Connect hoses (18) from the bottom cylinder parts to tee (20). Connect the elbow (21) to the tee and connect the hose (22) to the elbow. Connect hoses (19) from the top cylinder ports to tee (20). Connect elbow (21) to the tee and connect hose (22) to the elbow. Connect hoses (22) to hoses (23) and route hoses to the front of the machine. Fig. 15

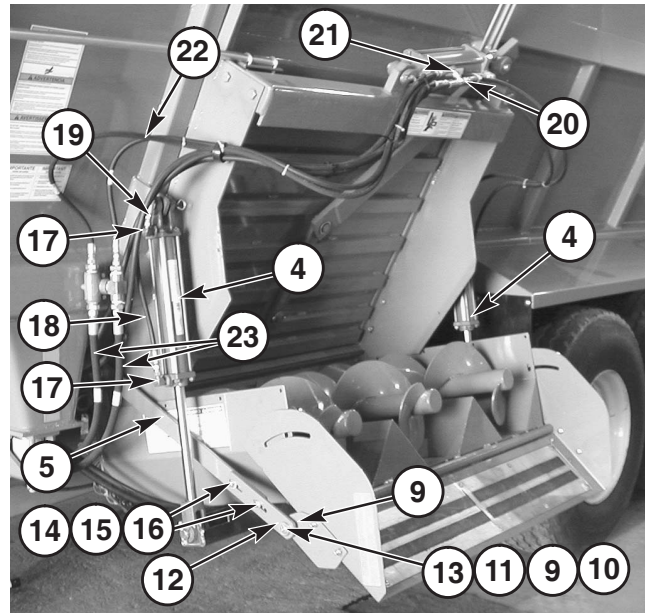
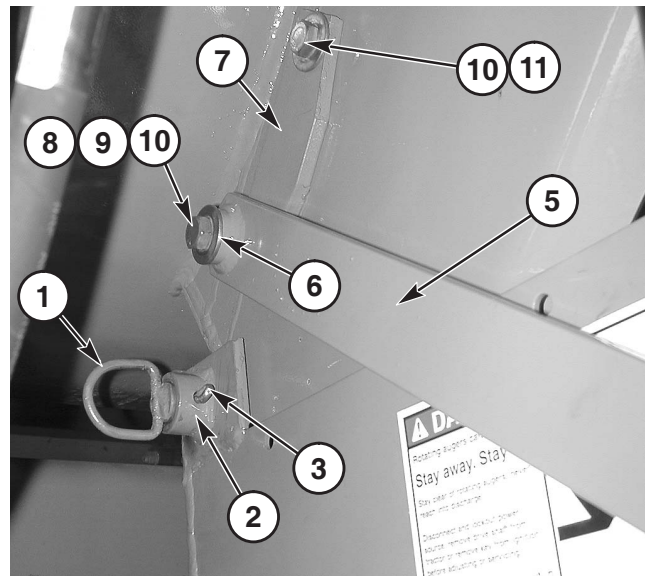

- 1 – Connecting Pin
- 2 – Discharge Bracket
- 3 – Cotter Pin
- 4 – Hydraulic Cylinder
- 5 – Inner Pivot Bars
- 6 – Bushings, 1/2" x 3/4" x 1-5/16"
- 7 – Pivot Bars
- 8 – Bolt, Hex 1/2-13 x 2-1/4"
- 9 – Washer, Plain 1/2"
- 10 – Nut, Hex Lock 1/2-13
- 11 – Bolt, Hex 1/2-13 x 2-1/4"
- 12 – Outer Pivot Bars
- 13 – Bushings, 1/2" x 3/4" x 11/16"
- 14 – Bolt, Carriage 3/8-16 x 1"
- 15 – Washer, Plain 3/8"
- 16 – Nut, Hex Lock 3/8-16
- 17 – Elbow 90° PT x 9/16" Flare
- 18 – Hose, 1/4" x 42"
- 19 – Hose, 1/4" x 30"
- 20 – Tee
- 21 – Elbow 90° 9/16" Flare
- 22 – Hose with ends 1/2" x 258"
- 23 – Hose with ends 3/4" x 156"

Fig. 15

INSTALLING AUGER DISCHARGE ON 5450, 5510, 5575, 5750 MIXER FEEDERS (Trailer/Truck)

1. Fit the discharge into position under the tube. Install the connecting pin (1) through discharge into the tube. Line up the hole in the discharge bracket (2) with the hole in the connecting pin (1). Install the cotter pin (3) and spread the cotter pin apart. Fig. 16
2. Install the discharge side (4) and spacer (5) to mounting brackets (6) on the mixer using bolts (7), flat washer (8), lock washer (9) and nut (10). Fig. 16
3. The discharge side (4) appear different for each size of mixer and length of discharge. Fig. 16
4. Install bolt (7), flat washer (8), lock washer (9), and nut (10) through discharge side (4) and discharge (11). Fig. 16
5. Refer to Page 12 for connecting the auger discharge hydraulics to the 5450, 5510, 5575 and 5750 Mixer Feeders. Fig. 16

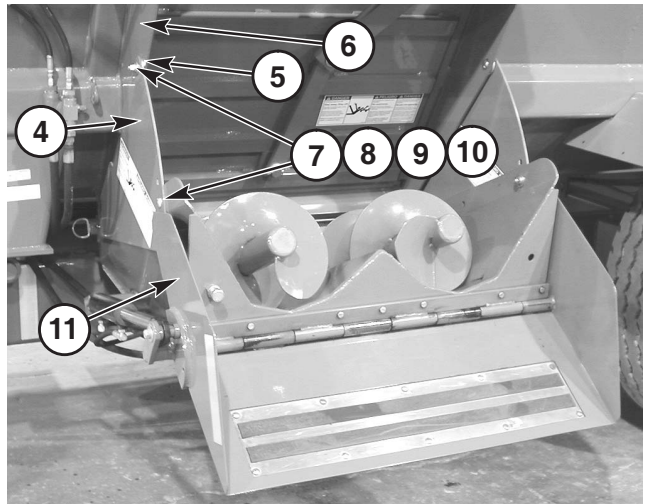
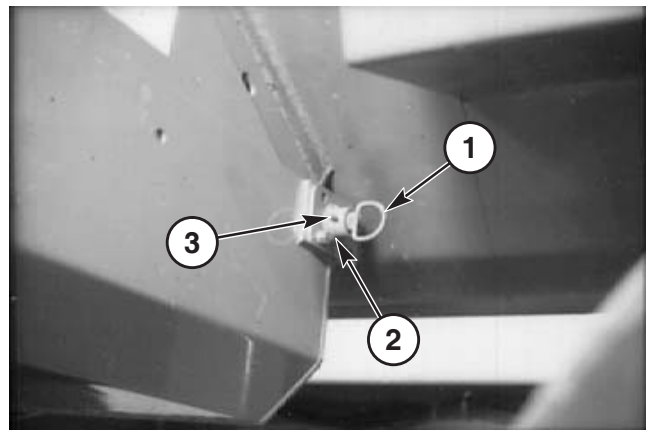

- 1 – Connecting Pin
- 2 – Discharge Bracket
- 3 – Cotter Pin
- 4 – Discharge Side
- 5 – Spacer Washer
- 6 – Mounting Brackets
- 7 – Bolt, Carriage 1/2–13 x 1-1/4” Grade 5
- 8 – Washer, Flat 1/2”
- 9 – Washer, Lock 1/2”
- 10 – Nut, Hex Lock 1/2–13
- 11 – Discharge

Fig. 16

HOOKING UP THE HYDRAULICS ON 5450, 5510, 5575, 5750 MIXER FEEDERS (TRAILER/TRUCK)

1. Install tractor hydraulic line (1) into port (2) of hydraulic motor (3). Install tractor hydraulic line (4) into port (5) of hydraulic motor (3). Fig. 17

NOTE: Tee on hydraulic motor (3) has a check valve (9) installed.

2. Install hydraulic line (6) of discharge drop chute cylinder (7) into tee of hydraulic line (1). Install hydraulic line (8) of cylinder into tee of hydraulic line (4). Fig. 17

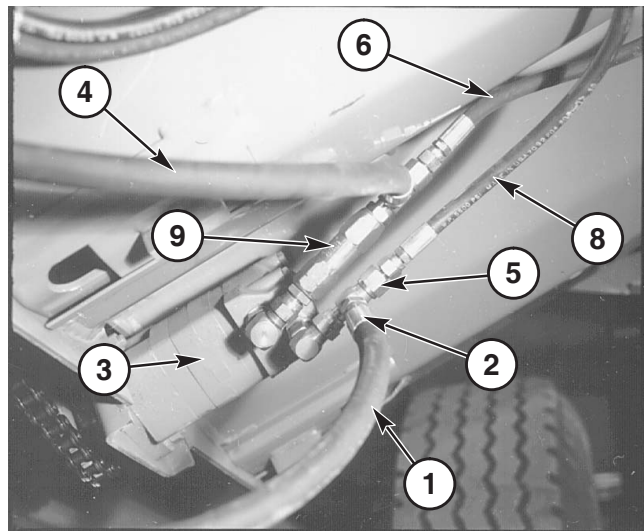
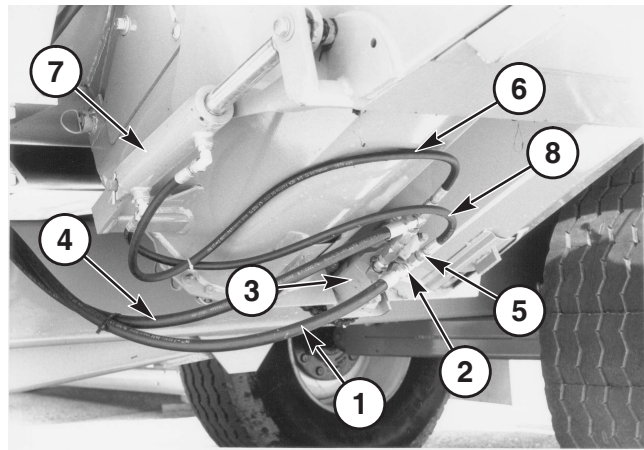

- 1 – Hydraulic Line
- 2 – Port, Hydraulic
- 3 – Hydraulic Motor
- 4 – Hydraulic Line
- 5 – Port, Hydraulic
- 6 – Hydraulic Line
- 7 – Cylinder, Discharge Drop Chute
- 8 – Hydraulic Line
- 9 – Check valve

Fig. 17

5950 MIXER FEEDER GRAVITY DISCHARGE (TRAILER/TRUCK)

1. Mount the discharge (1) to the door frame with four bolts (2), lock washers (3), plain washers (4), and nuts (5). Fig. 18

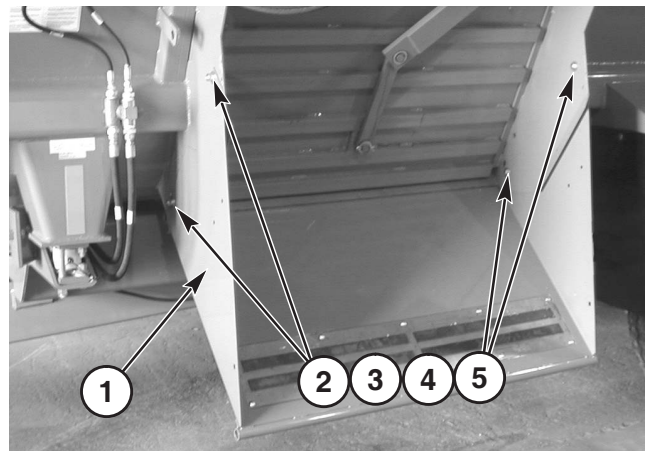

- 1 – Discharge
- 2 – Bolt, Carriage 1/2–13 x 1-1/2”
- 3 – Washer, Lock 1/2”
- 4 – Washer, Plain 1/2”
- 5 – Nut, Hex 1/2–13

Fig. 18

5950 MIXER FEEDER GRAVITY DISCHARGE SPOUT (TRAILER/TRUCK)

1. Mount the gravity spout (1) to the gravity discharge tube with the R.H. hinge pin (2) and the L.H. hinge pin (3), with bolts (4), lock washers (5), and nuts (6). Mount the cylinder pivot (7) to the front side of the gravity discharge with bolts (4), lock washers (5), and nuts (6). Mount the hydraulic cylinder (8) to the cylinder pivot and R.H. hinge pin. Apply liquid pipe sealant to the two elbows (9) that screw into the cylinder ports and install facing up. Connect the hydraulic hoses (10) to the elbows. Connect the adaptor (11) and male tip (12) to each hydraulic hose. Fig. 19
2. Apply liquid pipe sealant to the two elbows (9) that screw into the cylinder ports and install facing up. Connect the hydraulic hoses (10) to the elbows. Connect the adaptor (11) and male tip (12) to each hydraulic hose. Fig. 19

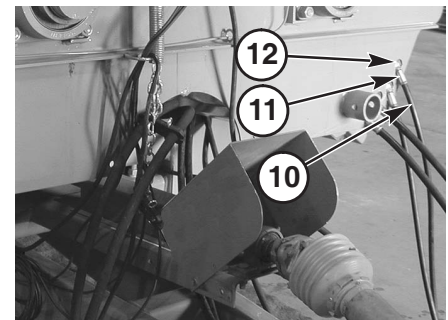
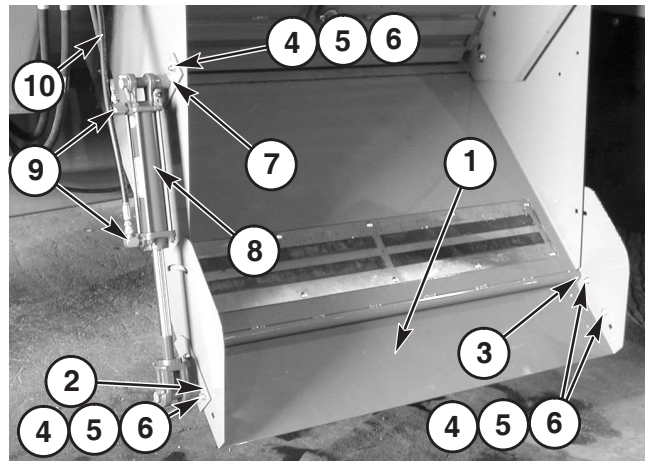

- 1 – Gravity Spout
- 2 – R.H. Hinge Pin
- 3 – L.H. Hinge Pin
- 4 – Bolt, Carriage 3/8–16 x 1”
- 5 – Washer, Lock 3/8”
- 6 – Nut, Hex 3/8–16
- 7 – Cylinder Pivot
- 8 – Hydraulic Cylinder
- 9 – Elbow 90° 3/8” NPT -9/16” FI
- 10 – Hydraulic Hose
- 11 – Adaptor 9/16–18 FL - 3/4–16 OR
- 12 – Male Tip 3/4–16 O-Ring Boss

Fig. 19

TRUCK-MOUNT MODELS

WARNING

Truck-Mounted Units – Body installer and owner are responsible for evaluating and providing any additional safety equipment that may be required for their specific installation.

1. Install plug (1) in the threaded hole on the underside of the rear drive compartment (2). Use sealant on the threads. Fig. 20

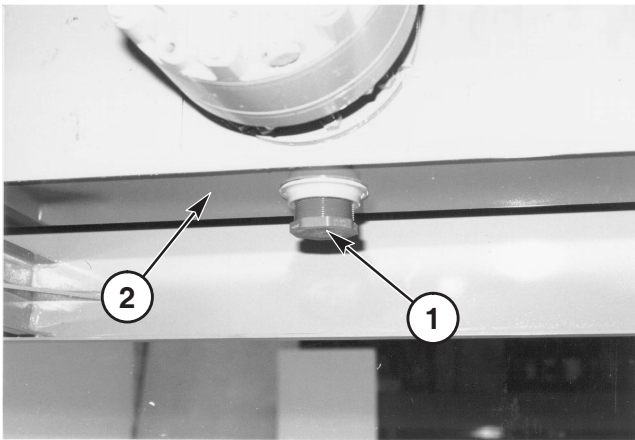

1 – Plug
2 – Rear drive compartment
Fig. 20

2. Open the rear drive compartment doors and add SAE 30W motor oil until it reaches the chain of the lower drive sprocket as shown. Rear drive compartment oil capacity is approximately 16 gallons U.S. (61 L). Fig. 20

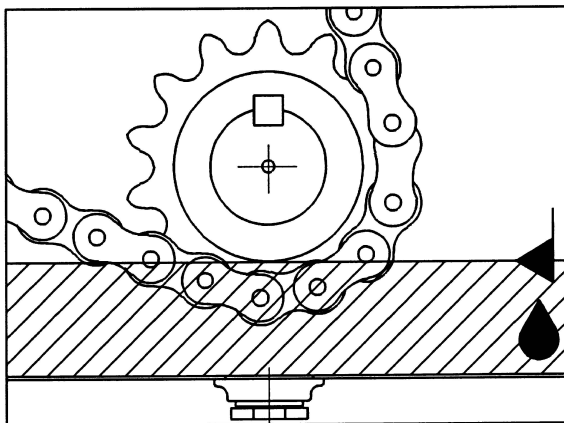
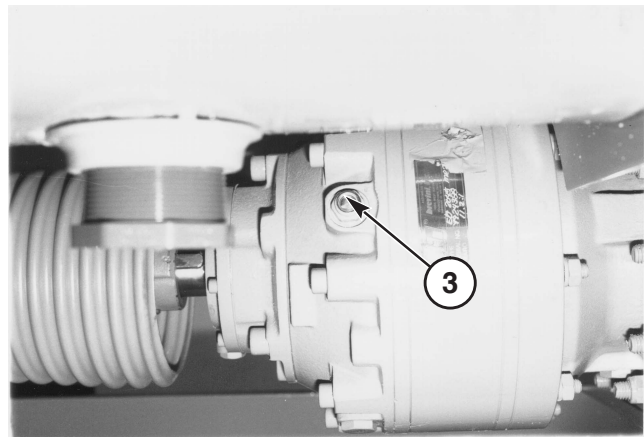

Fig. 21

3. Check the oil level in the planetary gearbox using the sight gauge (3) on the left side of the gearbox. Fig. 22



3 – Sight gauge

Fig. 22

4. Install two plugs (4) in the threaded holes on the rear underside of the mixing chamber (5). Fig. 23

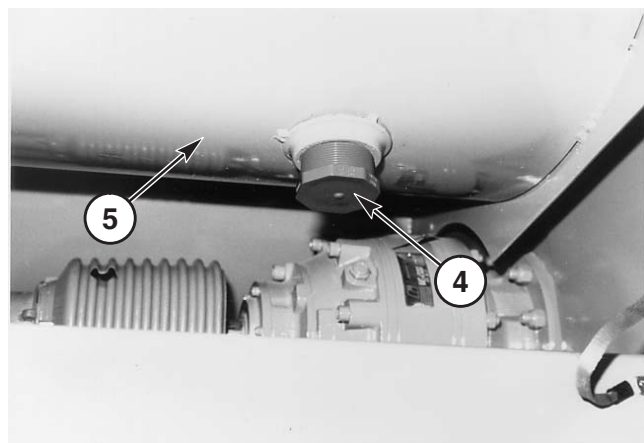

4 – Plug
5 – Mixing chamber

Fig. 23

5. Check for proper assembly, adjustment and lubrication. Check all bolts and setscrews and tighten as needed.
6. Be sure all shields are properly in place.
7. Check for and remove any foreign objects and tools in the mixing chamber, discharge chute, and oil bath reservoir area.

GEHL®

Gehl Company 143 Water Street, P.O. Box 179, West Bend, WI 53095-0179 U.S.A.
www.gehl.com