

# ***Hustler® FasTrak Super Duty 36/42 Parts Manual***



**HUSTLER®**

•••••

*Excel Industries, Inc.*

••••

*200 S. Ridge Road*

•••

*Hesston, Kansas*

•

67062



---

# Table of Contents

## General Information

Service Literature . . . . .	1-1
Options Available From Your Dealer. . . . .	1-1
Using This Manual . . . . .	1-1
Hardware Description Codes & Abbreviations . . . . .	1-2
Standard Torques . . . . .	1-2

## Section 2

Frame . . . . .	2-2
Footrest. . . . .	2-4
Engine Guard . . . . .	2-6

## Section 3

Hydraulic System . . . . .	3-2
Transmission Assembly . . . . .	3-8
Transmission Service Parts . . . . .	3-10
Steering. . . . .	3-12
Park Brake . . . . .	3-14

## Section 4

Wheel & Tire—Flex Forks. . . . .	4-2
Front Tire, Flex Forks . . . . .	4-4
Drive Wheel Breakdown . . . . .	4-6

## Section 5

Engine, Kawasaki FX600V—S/N 12082355 & Higher . . . . .	5-2
Engine, Kawasaki FX600V—S/N Prior to 12082355 . . . . .	5-6
Engine Service Parts, Kawasaki FX600V . . . . .	5-10
Fuel System—S/N 12082355 & Higher. . . . .	5-12
EVAP System—S/N Prior to 12082355 . . . . .	5-14
Fuel System—S/N Prior to 12082355. . . . .	5-16
Fuel System Service Parts . . . . .	5-18

## Section 6

Battery. . . . .	6-2
Instrument Panel. . . . .	6-4

## Section 7

36" Service Deck. . . . .	7-2
36" Deck Pulleys & Spindles. . . . .	7-4
36" Deck . . . . .	7-6
42" Service Deck. . . . .	7-8
42" Deck Pulleys & Spindles. . . . .	7-10
42" Deck . . . . .	7-12
Deck Lift . . . . .	7-14
Deck Mounting Hardware . . . . .	7-16

## Section 8

Seat. . . . .	8-2
ROPS . . . . .	8-6



---

# General Information

This Manual covers Hustler® FasTrak Super Duty 36" & 42" models **931253EX & 931261EX**.

---

## **Service Literature**

<b>PART NO.</b>	<b>DESCRIPTION</b>
603519	OPERATOR'S MANUAL
114191	WARRANTY STATEMENT
114660	GENERAL SERVICE MANUAL

---

## **Options Available From Your Dealer**

<b>PART NO.</b>	<b>DESCRIPTION</b>
600213	FLEX FORK
107654	MULCH KIT

*Note:* When ordering parts, you must use the part number as shown for each part, not the index number. Always give the model and serial number to your parts and service representative.

*Note:* Items sold in bulk such as seals and hoses are sold by the foot.

---

## **Using This Manual**

This manual is part of a service package for the Hustler® mowers. Use of this manual in conjunction with other Hustler® mower and component manuals will provide the information necessary to service and maintain Hustler® mowers.

This Parts Manual provides a complete parts listing for the unit. Use this manual when ordering parts. Illustrations used were current at the time of printing, but subsequent production changes may cause your machine to vary slightly in detail. Excel Industries, Inc. reserves the right to redesign and change the machine as deemed necessary, without notification. If a change has been made to your machine which is not reflected in this parts manual, see your authorized dealer for current information and parts.

The Service Manual is a service guide for use by Service Technicians. It provides the necessary information needed to perform normal maintenance requirements on these units.

The Operator's Manual provides fundamental operational information and operational safety that is needed when operating the mower.

The component manuals are furnished by the various manufacturers to be used for the troubleshooting and servicing of their products.

---

## **Hardware Description Codes & Abbreviations**

The following codes are used throughout this parts manual. Refer to this list when ordering parts.

<b>ABBREVIATION</b>	<b>DESCRIPTION</b>	<b>ABBREVIATION</b>	<b>DESCRIPTION</b>
CB	CARRIAGE BOLT	MB	MACHINE BUSHING
CE	CLEVIS PIN	MS	MACHINE SCREW
CN	CLIP NUT	NT	NUT
CP	COTTER PIN	SC	SELF TAPPING CAP SCREW
CS	CAP SCREW	SH	SOCKET HEAD
CW	CUP WASHER	SB	SHOULDER BOLT
FDRW	FENDER WASHER	SS	SET SCREW
FW	FLAT WASHER	OD	OUTSIDE DIAMETER
HX	HEX HEAD	ID	INSIDE DIAMETER
LW	LOCK WASHER		

---

## **Standard Torques**

The following chart lists the standard torque values for the threaded fasteners found in this manual. Torque all cap screws, nuts and set screws to these values unless a different torque is shown in the Notes section next to the fastener.

<b>SIZE</b>	<b>FT-LBS</b>	<b>N-M</b>	<b>SIZE</b>	<b>FT-LBS</b>	<b>N-M</b>
.250	8.2	11.1	M3	1	1.3
.312	17	23	M4	2.2	3
.375	30	40	M5	4.5	6.1
.438	48	65	M6	7.7	10.4
.500	73	99	M8	18.5	25
.562	105	143	M10	37	50
.625	145	200	M12	64	87
.750	260	350	M14	80	108.5
.875	420	565	M16	160	215
1.00	625	850	M20	320	435
			M24	555	750

---

## Section 2

Frame .....	2-2
Footrest .....	2-4
Engine Guard.....	2-6

# Frame

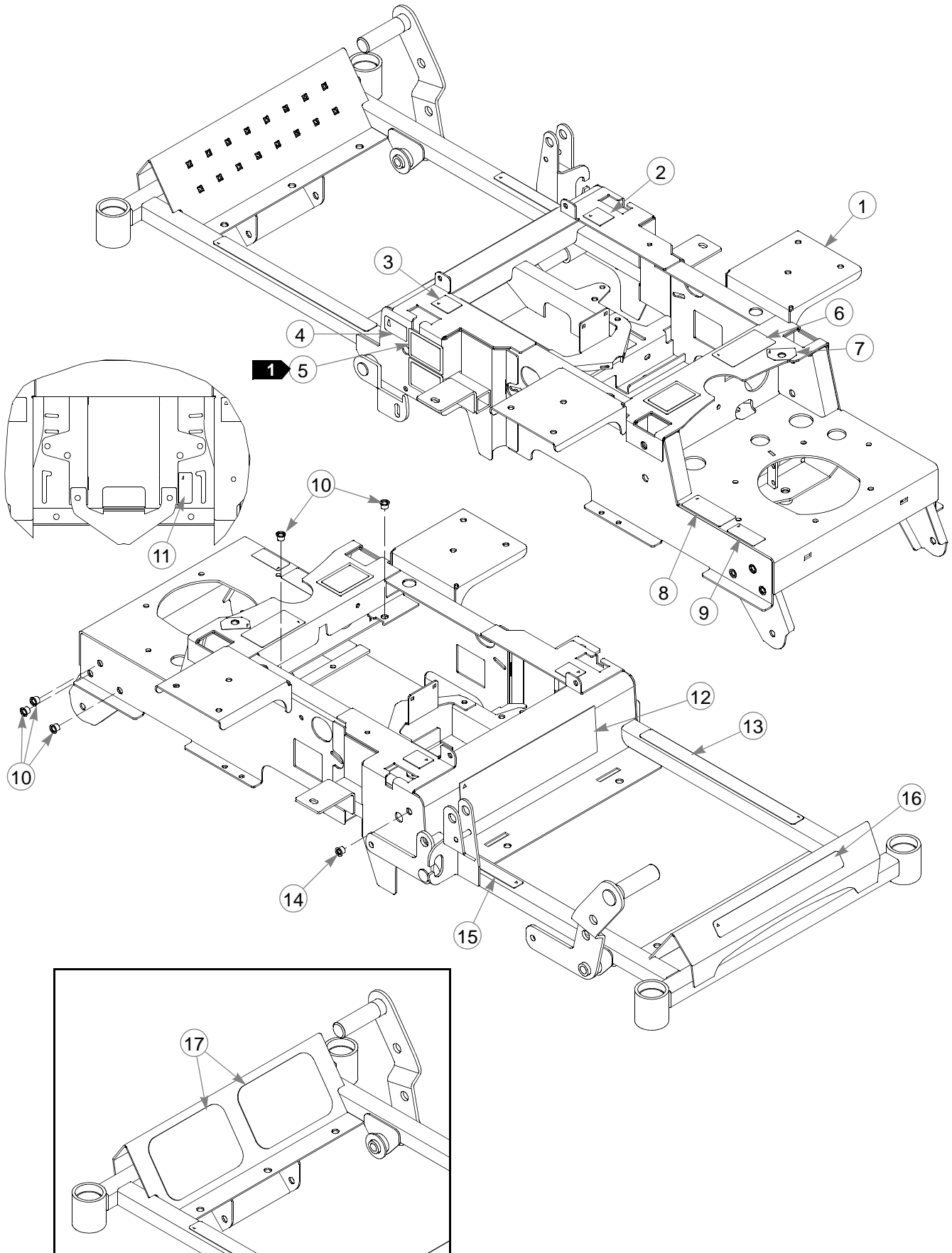



---

# **Frame**

INDEX NO.	PART NO.	QTY	DESCRIPTION
1	551085	1	36" FRAME (WITH DECALS & RIVET NUTS)
	551086	1	42" FRAME (WITH DECALS & RIVET NUTS)
2	785220	1	RS STEERING DECAL
3	785139	1	LS STEERING DECAL
4	727172	1	MADE IN U.S.A.
5	N/A	1	SERIAL NUMBER / SPEC DECAL
6	600899	1	PUMP BELT WARNING DECAL
7	791848	1	FUEL INDICATOR DECAL
8	601967	1	ENGINE COMPARTMENT DECAL
9	602041	1	HOT DECAL
10	808493	8	3/8-16 THREAD RIVET NUT
11	603542	1	TOW VALVE DECAL
12	601421	1	FASTRAK SUPER DUTY ID DECAL
13	601993	1	SAFE OPERATION DECAL
14	808485	1	5/16-18 THREAD RIVET NUT
15	785154	1	DECK HEIGHT DECAL
16	602407	1	HUSTER ID DECAL
17	785485	2	STEP TREAD (S/N PRIOR TO 13010000)

---

## **NOTES:**

1. In the event the serial number tag becomes damaged or illegible, please contact your dealer to order a replacement.

# **Footrest**

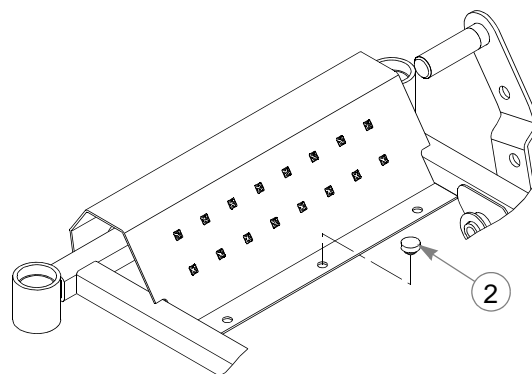
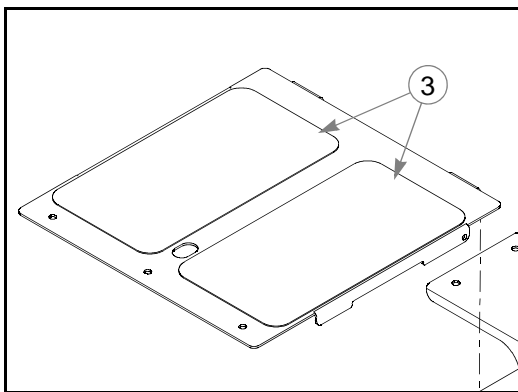
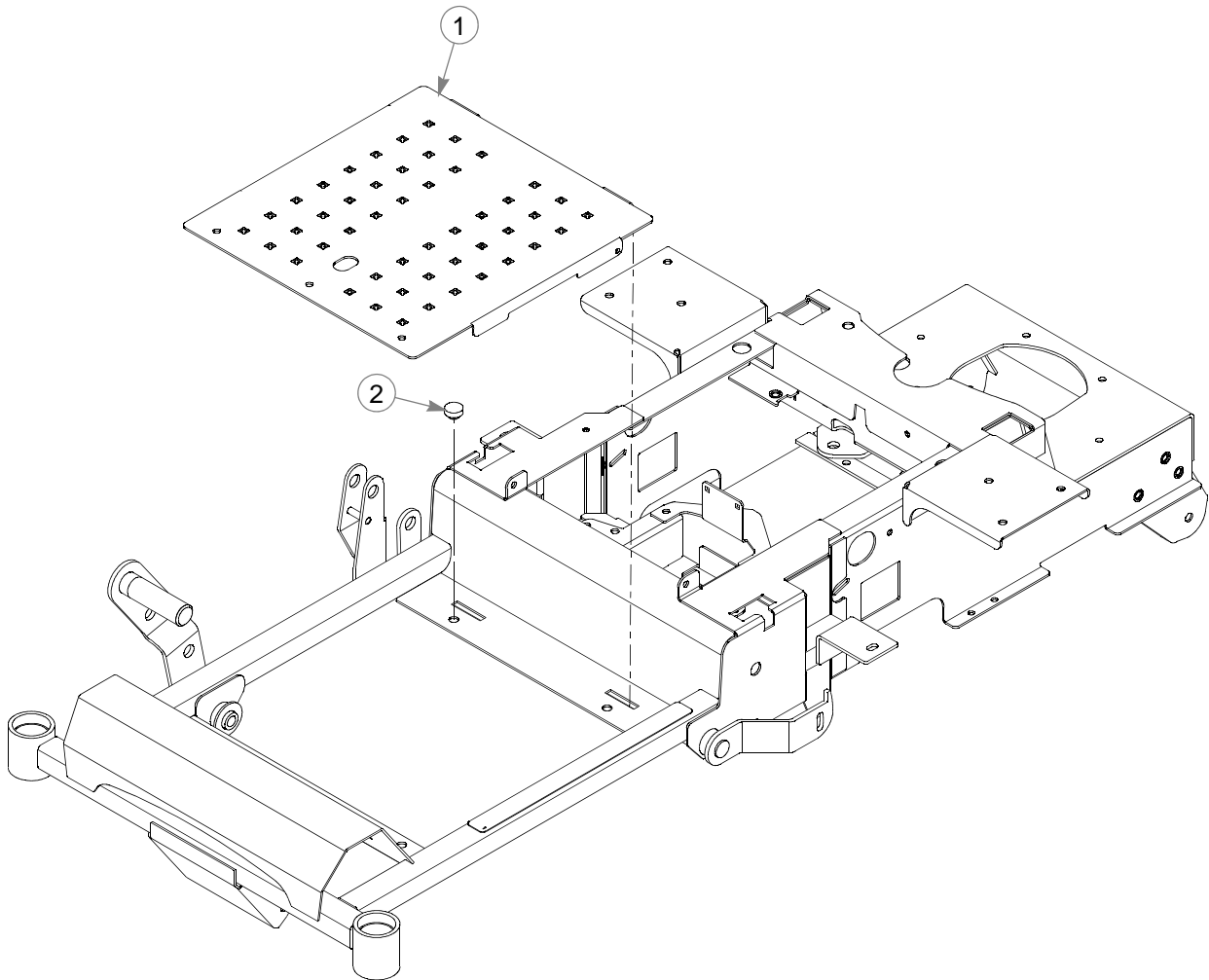

---

# **Footrest**

INDEX NO.	PART NO.	QTY	DESCRIPTION
1	551087	1	FLOOR PLATE
2	781880	5	BUMPER
3	601986	2	STEP TREAD (S/N PRIOR TO 13010000)

---

**NOTES:**

# Engine Guard

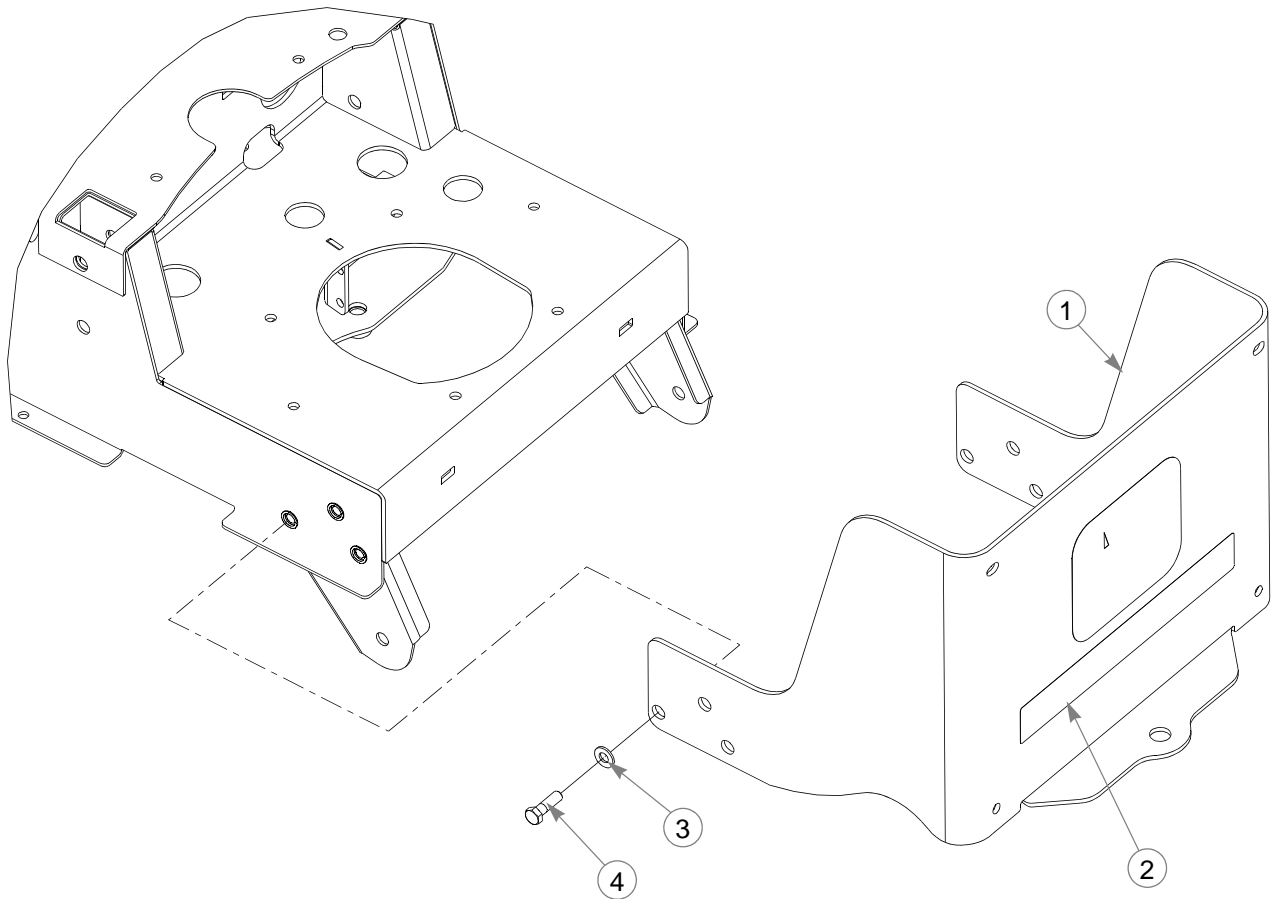

THIS ONE-PIECE GUARD REPLACES  
THE THREE-PIECE GUARD.

---

INDEX NO.	PART NO.	QTY.	DESCRIPTION
1	118185	1	ENGINE GUARD
2	604745	1	HUSTLER DECAL
3	767954	6	FW .406 X .812 X .060 SAE
4	052860	6	CS .375-16 X 1.25 HX G5 ZN

---

## NOTES:

---

## Section 3

Hydraulic System . . . . .	3-2
Transmission Assembly . . . . .	3-8
Transmission Service Parts . . . . .	3-10
Steering . . . . .	3-12
Park Brake . . . . .	3-14

# Hydraulic System

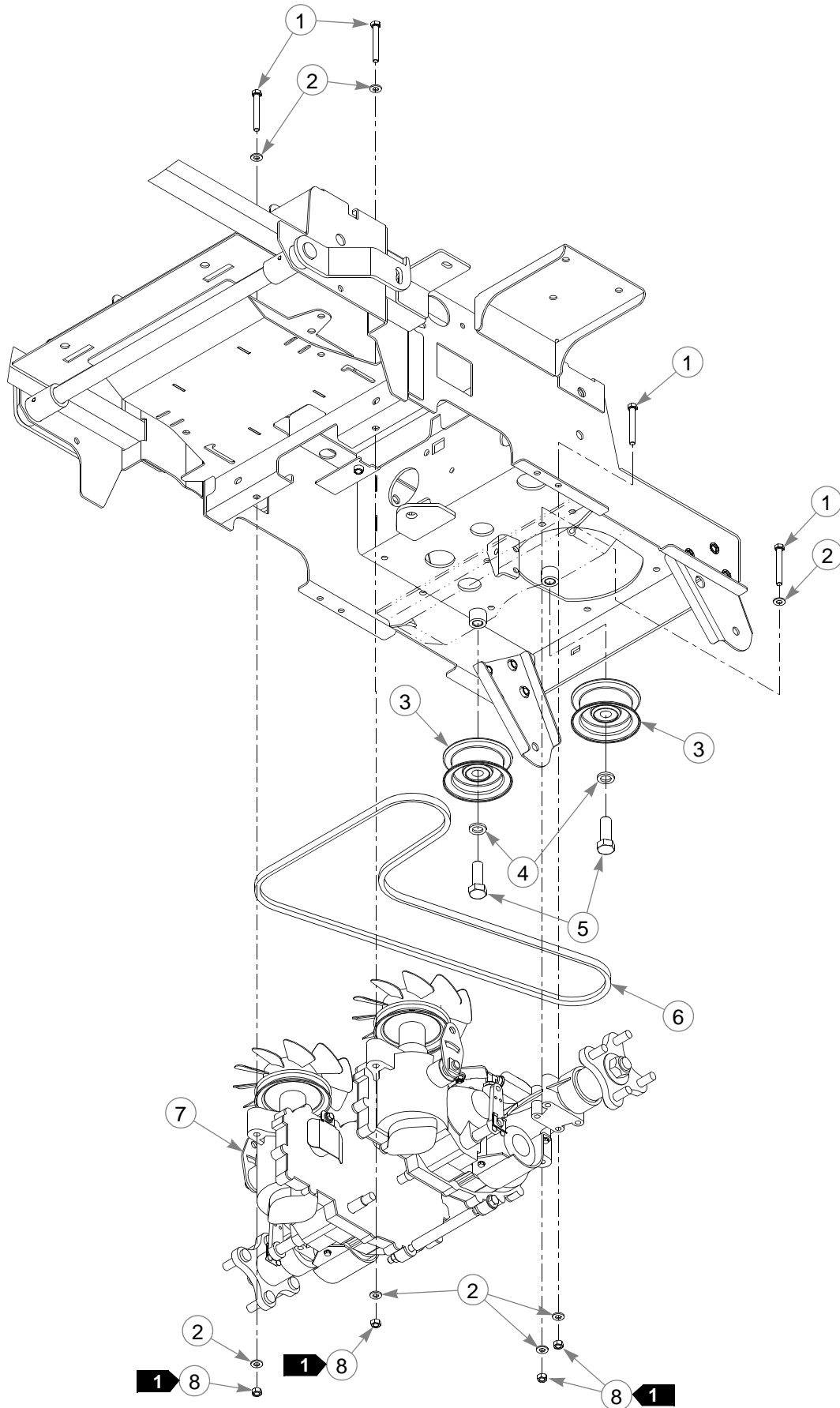

---

## **Hydraulic System**

INDEX NO.	PART NO.	QTY.	DESCRIPTION
1	710087	8	CS .312-18 X 2.50 HX G5
2	768523	12	FW .343 X .687 X .051/.080H
3	601162	2	IDLER PULLEY
4	028118	5	FW .625 X 1.00 X .134 ZNYC
5	025007	2	CS .625-11 X 1.75 HX G5
6	602253	1	BELT, A SEC, 67.6 EL
7	N/A	1	TRANSMISSION ASSEMBLY
8	034272	8	NT .312-18 HX G5 ZNYC

---

### **NOTES:**

1. Torque to 17 ft-lbs.

# Hydraulic System

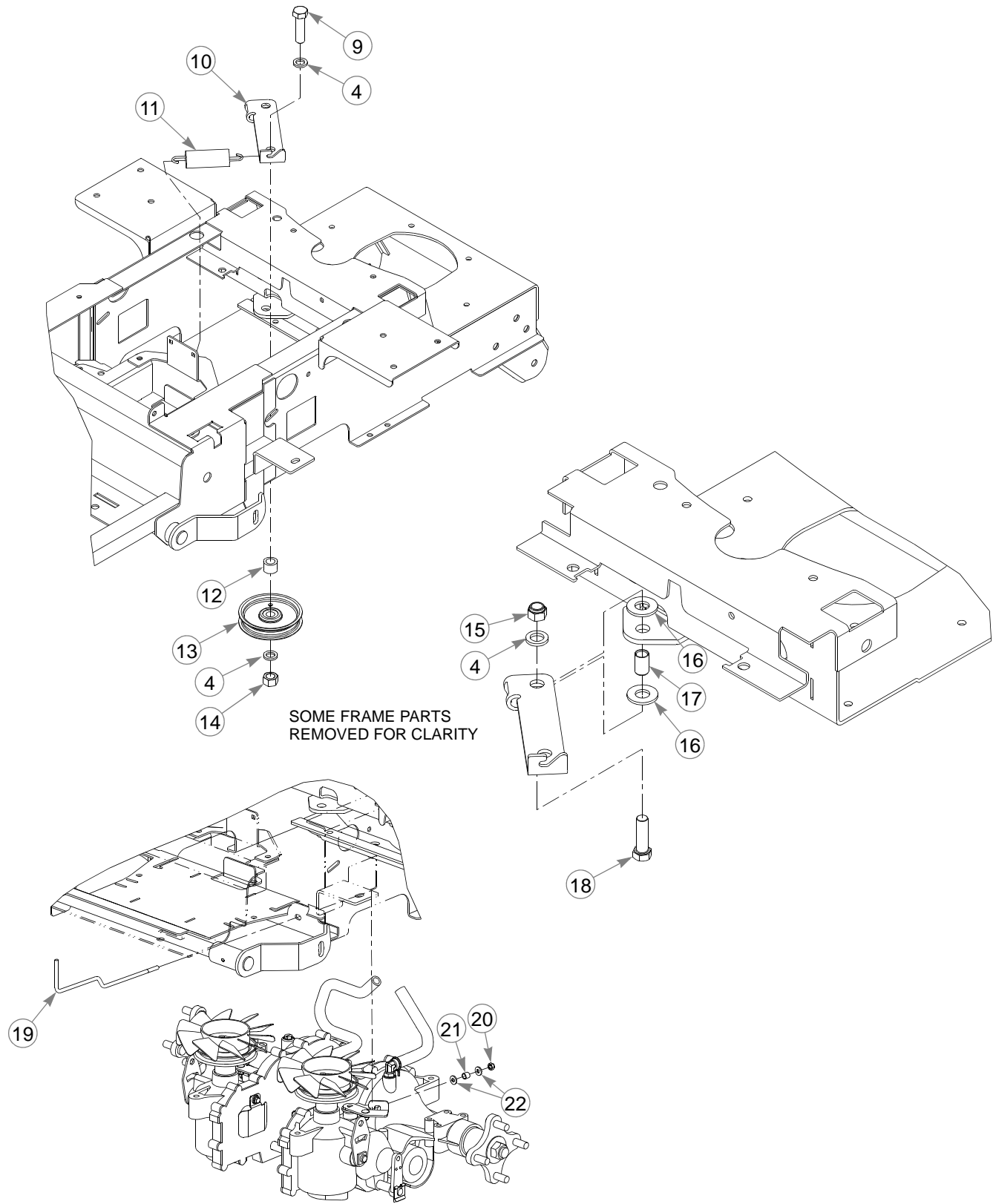



---

## **Hydraulic System**

INDEX NO.	PART NO.	QTY.	DESCRIPTION
9	601983	1	CS .625-11 X 2.25 HX G5 ZY
10	111079	1	PUMP IDLER
11	036384	1	SPRING 1/4 COIL
12	601398	1	IDLER SPACER
13	786848	1	IDLER PULLEY
14	016972	1	NT .625-11 HX G5 ZNYC
15	781567	1	NT .500-13 HX G8 ZY NL
16	602026	2	BEARING DISC
17	602025	1	BUSHING
18	017616	1	CS .500-13 X 1.75 HX G5
19	603486	2	TOW LINK ROD
20	068551	2	NT .250-20 HX ZY NL
21	041988	2	SPRING
22	768515	6	FW .281 X .625 X .051/.080 HD ZN/YL

---

### **NOTES:**

# Hydraulic System

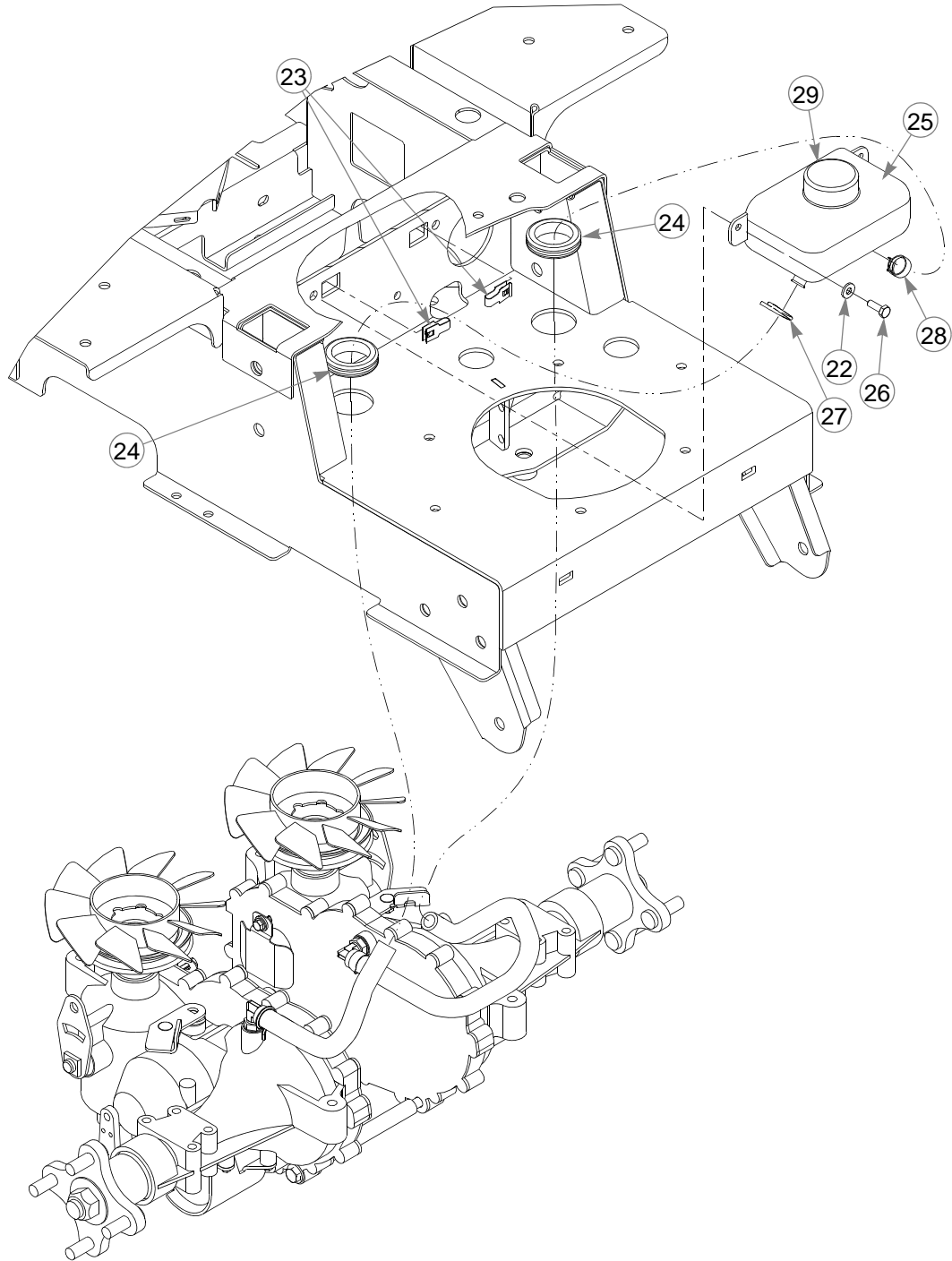

---

## **Hydraulic System**

<b>INDEX NO.</b>	<b>PART NO.</b>	<b>QTY.</b>	<b>DESCRIPTION</b>
23	601118	2	CN .250-20 X .19 MAX THK
24	794644	2	GROMMET
25	600759	1	OVERFLOW TANK (WITH CAP)
26	055939	2	CS .250-20 X .75 HX G5
27	601001	1	SPRING CLAMP
28	601474	1	SPRING CLAMP
29	600767	1	OVERFLOW TANK CAP

---

### **NOTES:**

# Transmission Assembly

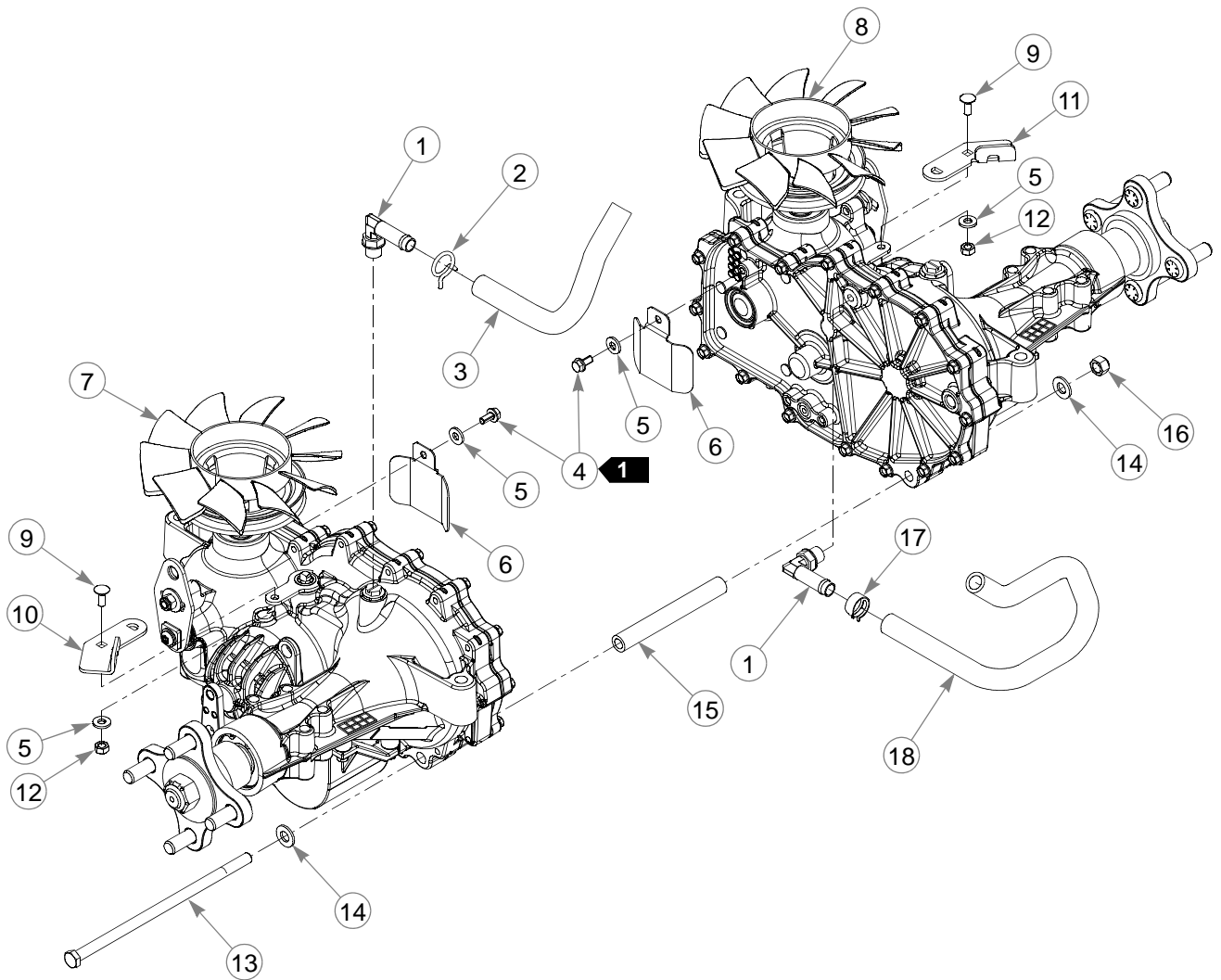

---

## **Transmission Assembly**

INDEX NO.	PART NO.	QTY.	DESCRIPTION
1	601219	2	FITTING, 90 - 9/16 SAE
2	601001	1	SPRING CLAMP
3	787713	8.50"	HOSE, 0.50" LOW PRESSURE
4	603617	2	SC .250-20 X .50 HX FL STP
5	768515	4	FW .281 X .625 X .051/.080 HD ZN/YL
6	114974	2	TRANSMISSION GUARD
7	601197	1	LS TRANSMISSION
8	601196	1	RS TRANSMISSION
9	601503	2	CB .250-20 X .625 ZNYC
10	111617	1	RS TOW VALVE BRACKET
11	111616	1	LS TOW VALVE BRACKET
12	068551	2	NT .250-20 HX ZY NL
13	600965	1	CS .375-16 X 8.50 G5 HX ZN
14	767954	2	FW .406 X .812 X .060 SAE
15	107633	1	SPACER
16	086660	1	NT .375-16 HX ZY NL
17	601474	1	SPRING CLAMP
18	603476	1	HOSE

---

### **NOTES:**

1. Torque to 10 ft-lbs.

# **Transmission Service Parts**

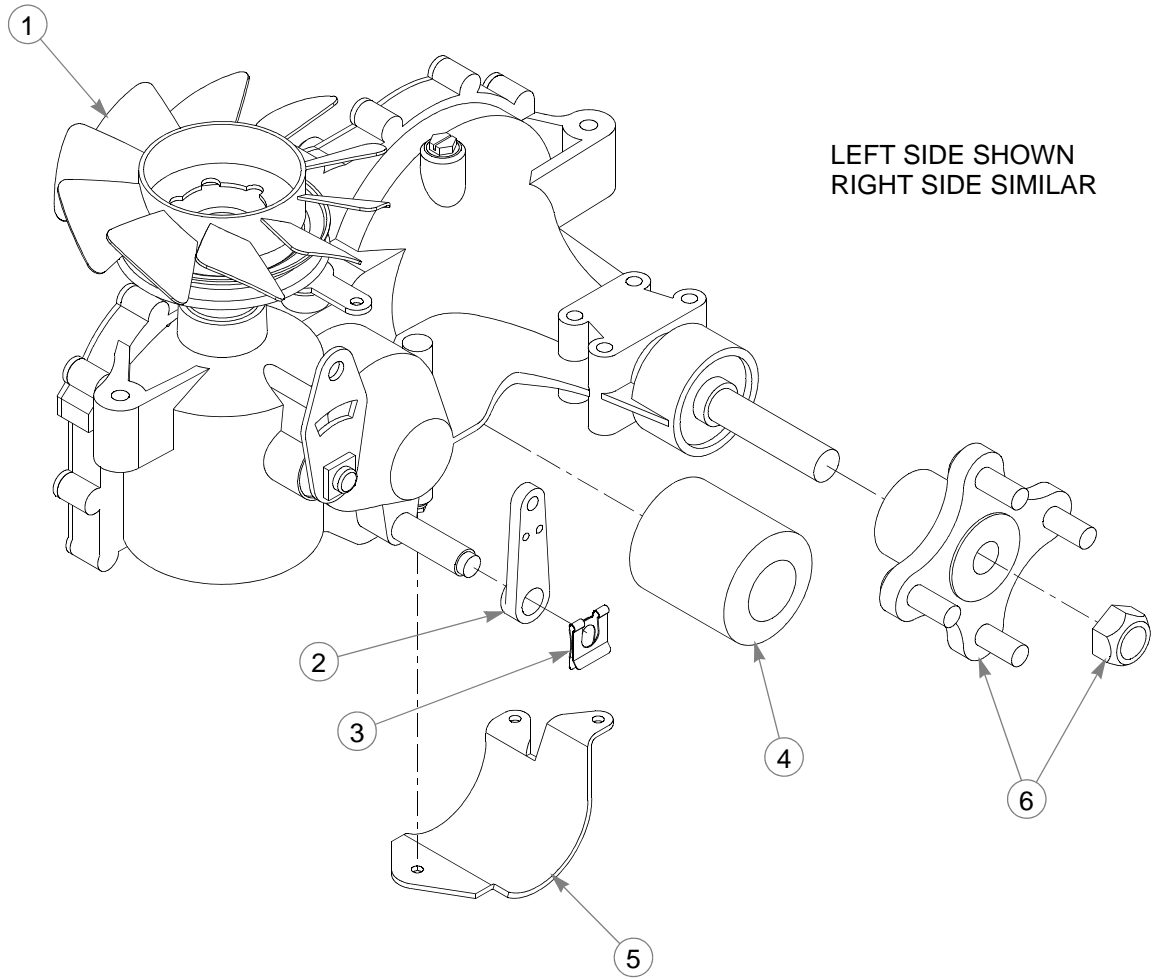

---

## ***Transmission Service Parts***

INDEX NO.	PART NO.	QTY.	DESCRIPTION
1	601941	1	FAN/PULLEY KIT
2	601221	1	BRAKE ARM
3	600972	1	RETAINING CLIP
4	600976	1	OIL FILTER
5	600975	1	LS FILTER GUARD
	600974	1	RS FILTER GUARD (NOT SHOWN)
6	600970	1	4 BOLT HUB KIT

---

### **NOTES:**

# Steering

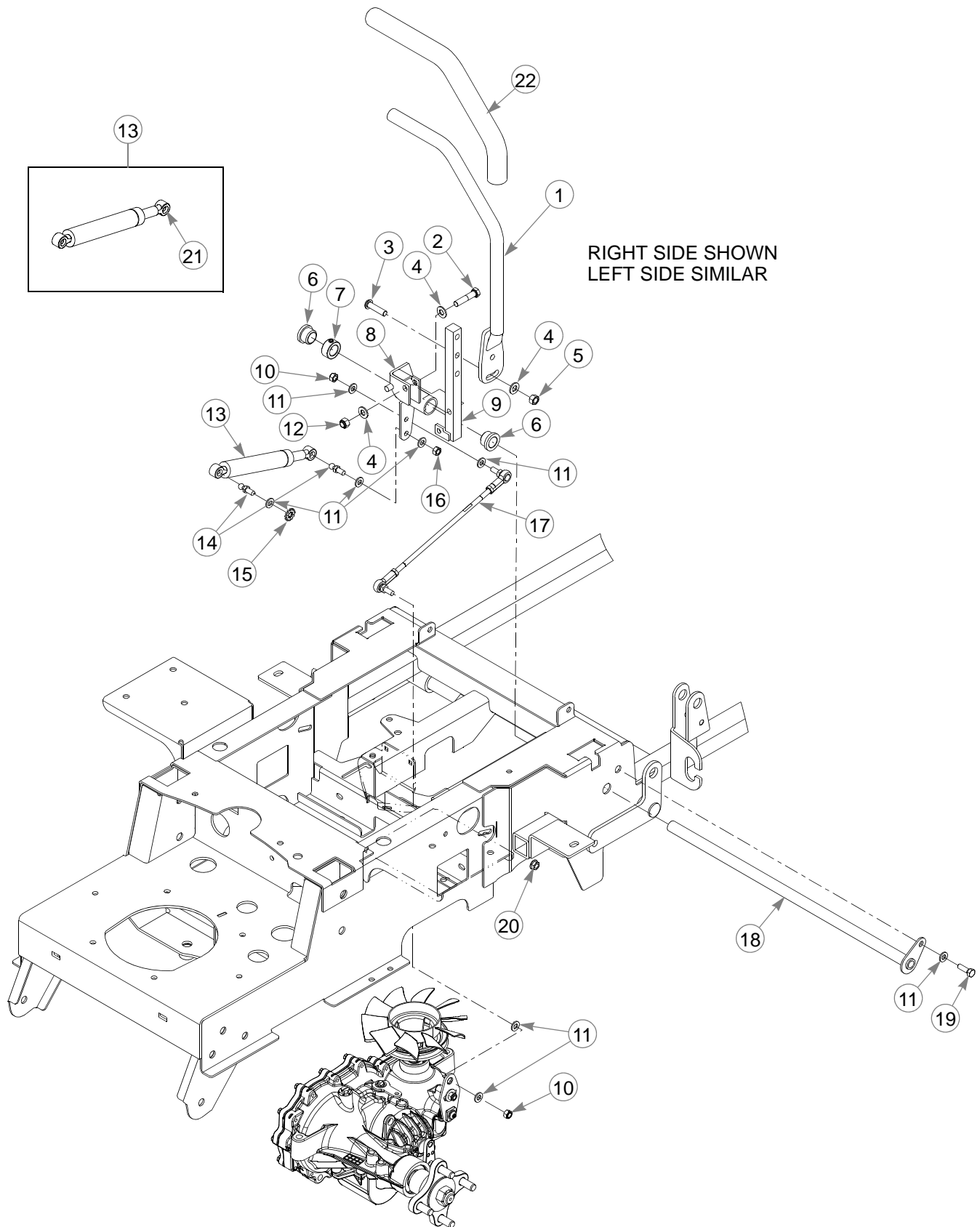



---

# **Steering**

INDEX NO.	PART NO.	QTY.	DESCRIPTION
1	110370	2	STEERING BAR (WITH GRIP)
2	705178	2	CS .375-16 X 1.75 HX G5
3	604816	4	CS .375-16 X 1.50 BH BO
4	767954	8	FW .406 X .812 X .060 SAE
5	054502	4	NT .375-16 HX G5 ZNY
6	781153	4	BUSHING
7	784439	2	LOCK COLLAR 0.757 ID
8	603477	1	RS STEER BOX
	603478	1	LS STEER BOX (NOT SHOWN)
9	603483	1	RS STEER LEVER
	603484	1	LS STEER LEVER (NOT SHOWN)
10	023655	4	NT .312-24 HX NL ZN
11	768523	15	FW .343 X .687 X .051/.080H
12	086660	2	NT .375-16 NL G5
13	600221	2	STEERING DAMPER
14	781922	4	BALL STUD
15	029876	2	LW .312 INT-EXT TOOTH
16	034272	2	NT .312-18 HX G5 ZNYC
17	600981	2	PUMP ROD
18	110014	1	PIVOT TUBE
19	036236	1	CS .312-18 X 1.00 HX G5
20	016832	2	NT .312-18 HX FLK ZNYC
21	601426	1	CAP LOCK
22	781260	1	STEERING BAR GRIP

---

## **NOTES:**

# Park Brake

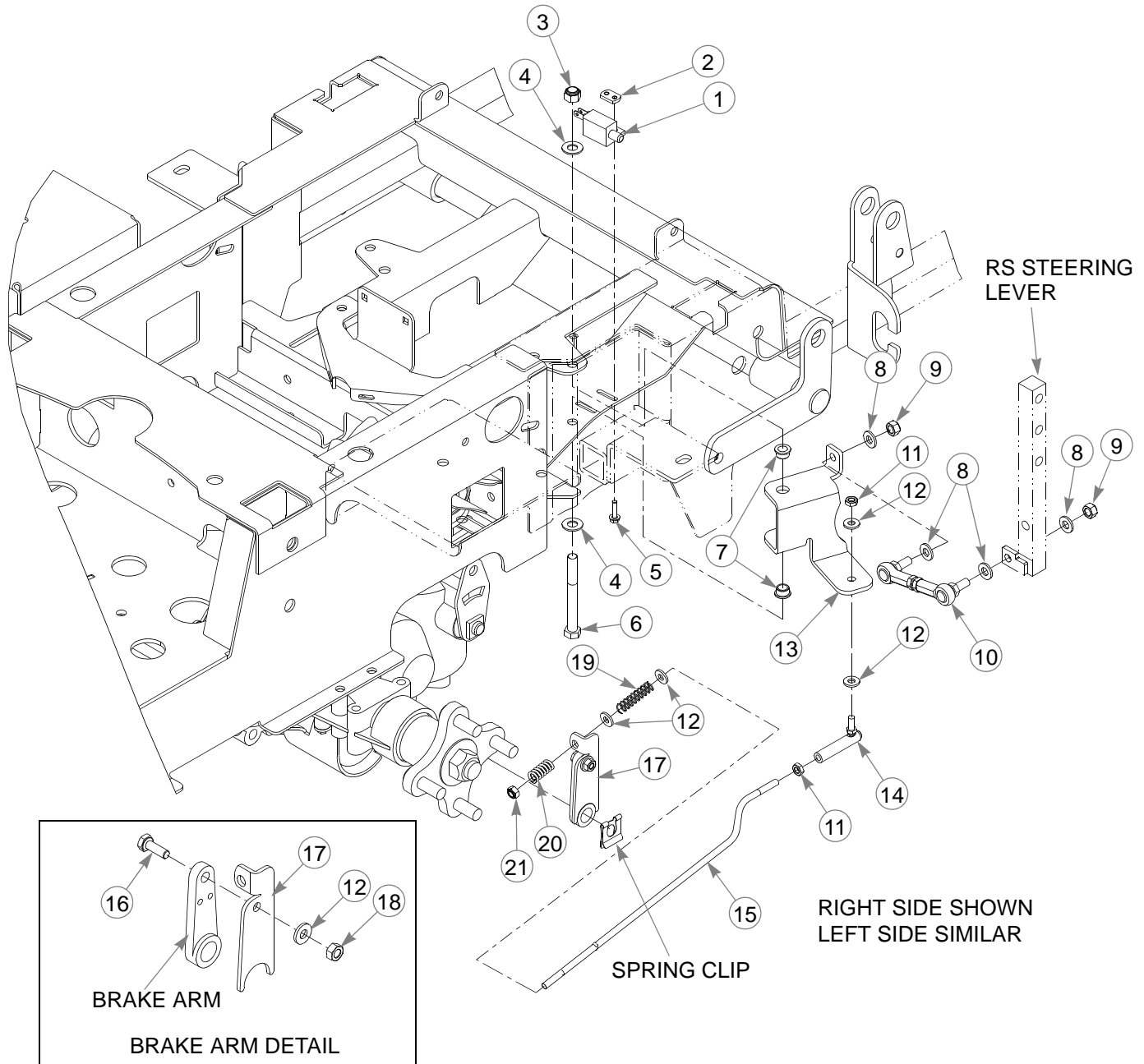

---

## **Park Brake**

INDEX NO.	PART NO.	QTY.	DESCRIPTION
1	781211	2	PUSH BUTTON SWITCH
2	601822	2	NUT PLATE, .420 CENTERS
3	086660	2	NT .375-16 NL G5
4	767954	4	FW .406 X .812 X .060 SAE
5	063198	4	CS 10-24 X .75 HX FLK ZN
6	005108	2	CS .375-16 X 3.50 HX G5 Z
7	765339	4	BUSHING
8	768523	8	FW .343 X .687 X .051/.080H
9	023655	4	NT .312-24 HX NL ZN
10	781583	2	BRAKE ROD ASSEMBLY
11	058842	4	NT .250-28 HX JAM ZNYC
12	768515	10	FW .281 X .625 X .051/.080 HD ZN/YL
13	114628	1	RS BELLCRANK
	114629	1	LS BELLCRANK (NOT SHOWN)
14	601201	2	BALL JNT, W/ STUD 1/4-28
15	603485	2	BRAKE ROD
16	055939	2	CS .250-20 X .75 HX G5
17	108588	1	RS ACT BRACKET
	108598	1	LS ACT BRACKET (NOT SHOWN)
18	024927	2	NT .250-20 HX G5 ZNYC
19	061572	2	SPRING
20	601211	2	OVERTRAVEL SPRING
21	068551	2	NT .250-20 HX ZY NL

---

### **NOTES:**



---

## Section 4

Wheel & Tire—Flex Forks . . . . .	4-2
Front Tire, Flex Forks . . . . .	4-4
Drive Wheel Breakdown . . . . .	4-6

# Wheel & Tire—Flex Forks

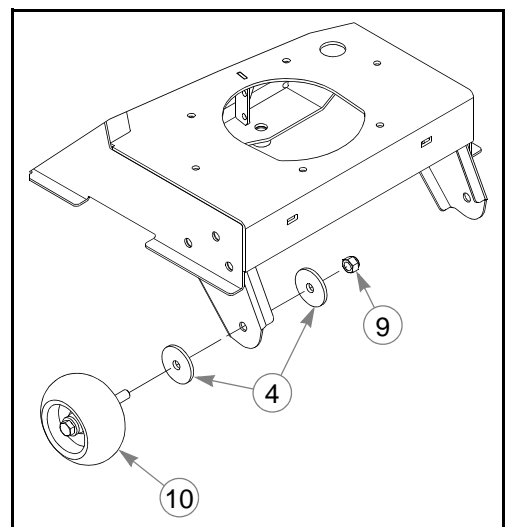
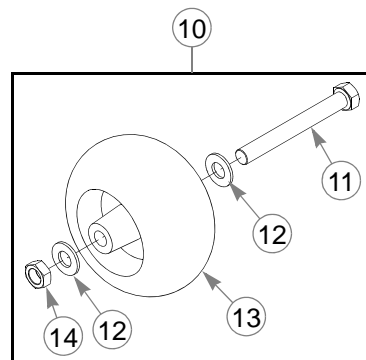
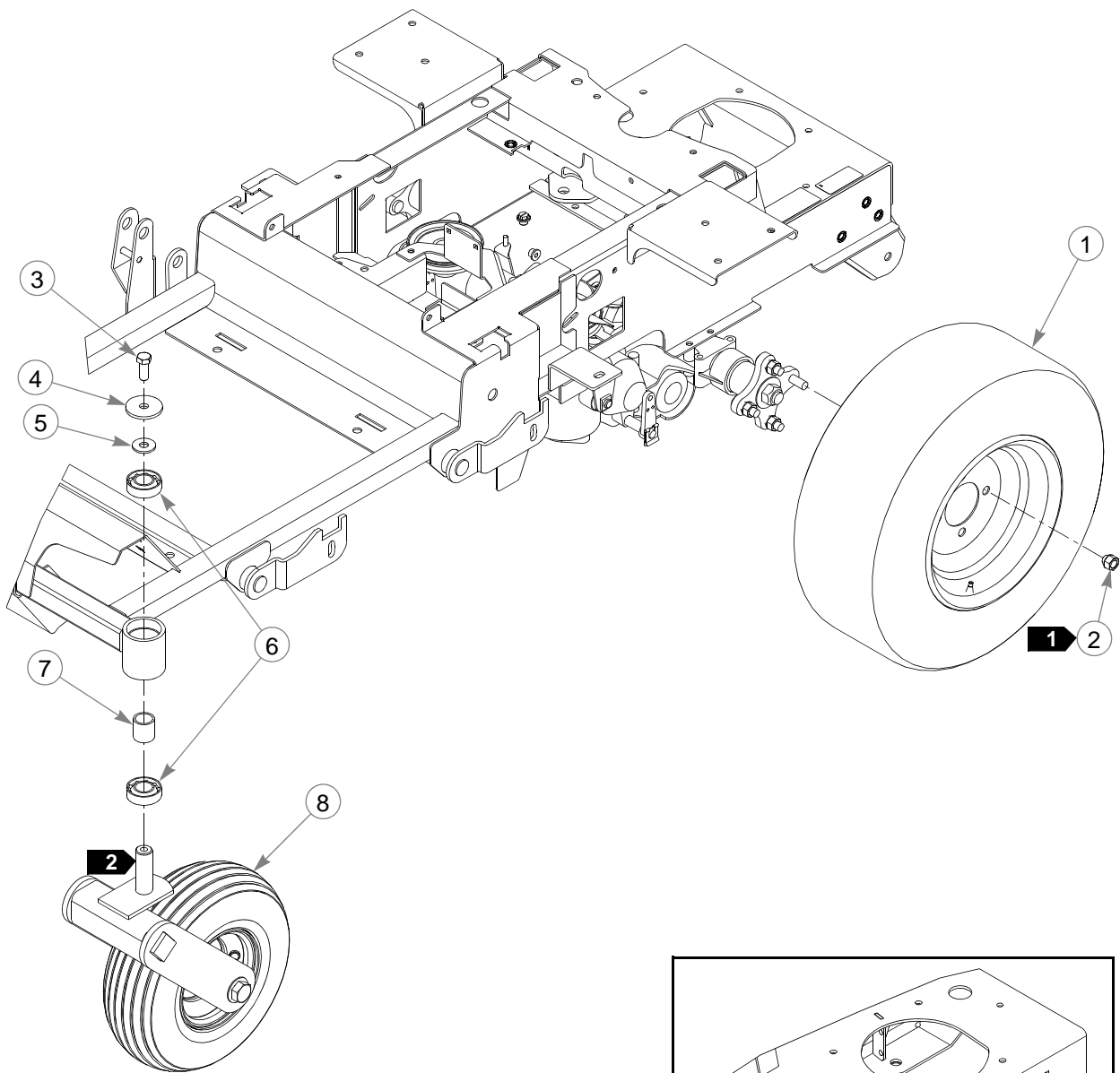

---

## **Wheel & Tire—Flex Forks**

INDEX NO.	PART NO.	QTY.	DESCRIPTION
1	600676	2	TIRE/WHEEL 20 X 8-10
2	061077	8	WHEEL NUT
3	705954	2	CS .500-13 X 1.25 HX G5 ZN
4	344267	6	FW .510 X 2.15 X .187 SPL
5	712976	2	FW .531 X 1.375 X .125 ZNY
6	784223	4	BEARING
7	784603	2	SPACER
8	N/A	1	FRONT TIRE ASSEMBLY
9	781567	2	NT .500-13 HX G8 ZY NL
10	788166	2	PLASTIC WHEEL ASSEMBLY (WITH HARDWARE)
11	781708	2	CS .500-13 X 4.25 HX G5
12	767962	4	FW .531 X 1.063 X .090 SAE
13	031997	2	PLASTIC WHEEL
14	053199	2	NT .500-13 HX JAM ZNYC

---

### **NOTES:**

1. Torque to 65–75 ft-lbs.
2. The Flex Fork Kit contains two forks.

# **Front Tire, Flex Forks**

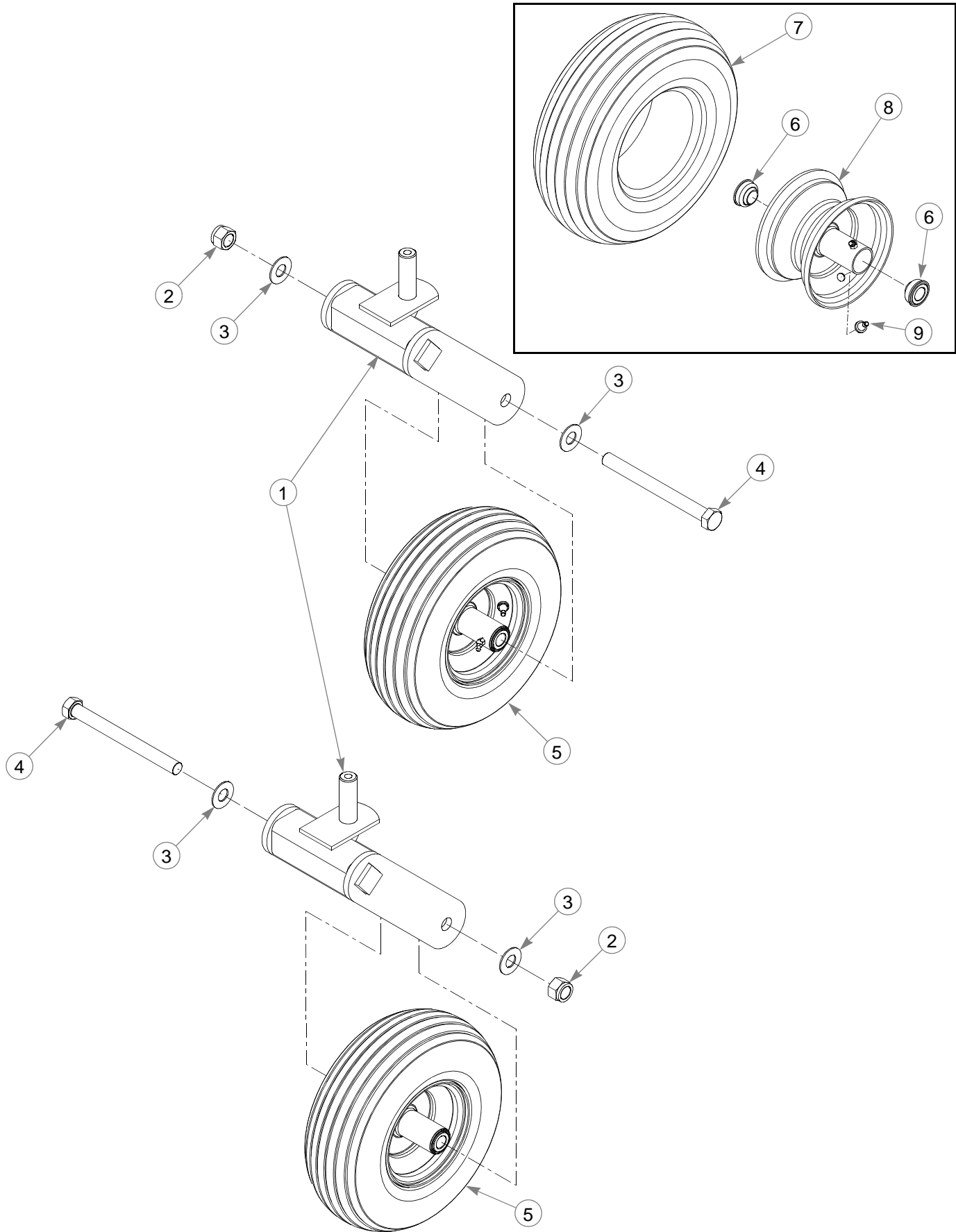



---

## **Front Tire, Flex Forks**

<b>INDEX NO.</b>	<b>PART NO.</b>	<b>QTY.</b>	<b>DESCRIPTION</b>
1	600213	1	FLEX FORK KIT (CONTAINS TWO FORKS)
2	061101	2	NT .750-10 HX ZY NL
3	025296	4	FW .760 X 1.625 X .08 ZNYC
4	786731	2	CS .750-10 X 8.00 HX G5
5	786061	2	TIRE/WHEEL 13 X 5.00
6	786103	2	WHEEL BEARING
7	747402	1	TIRE 13 X 5.00
8	786079	1	WHEEL
9	019521	1	TIRE VALVE

---

### **NOTES:**

---

## **Drive Wheel Breakdown**

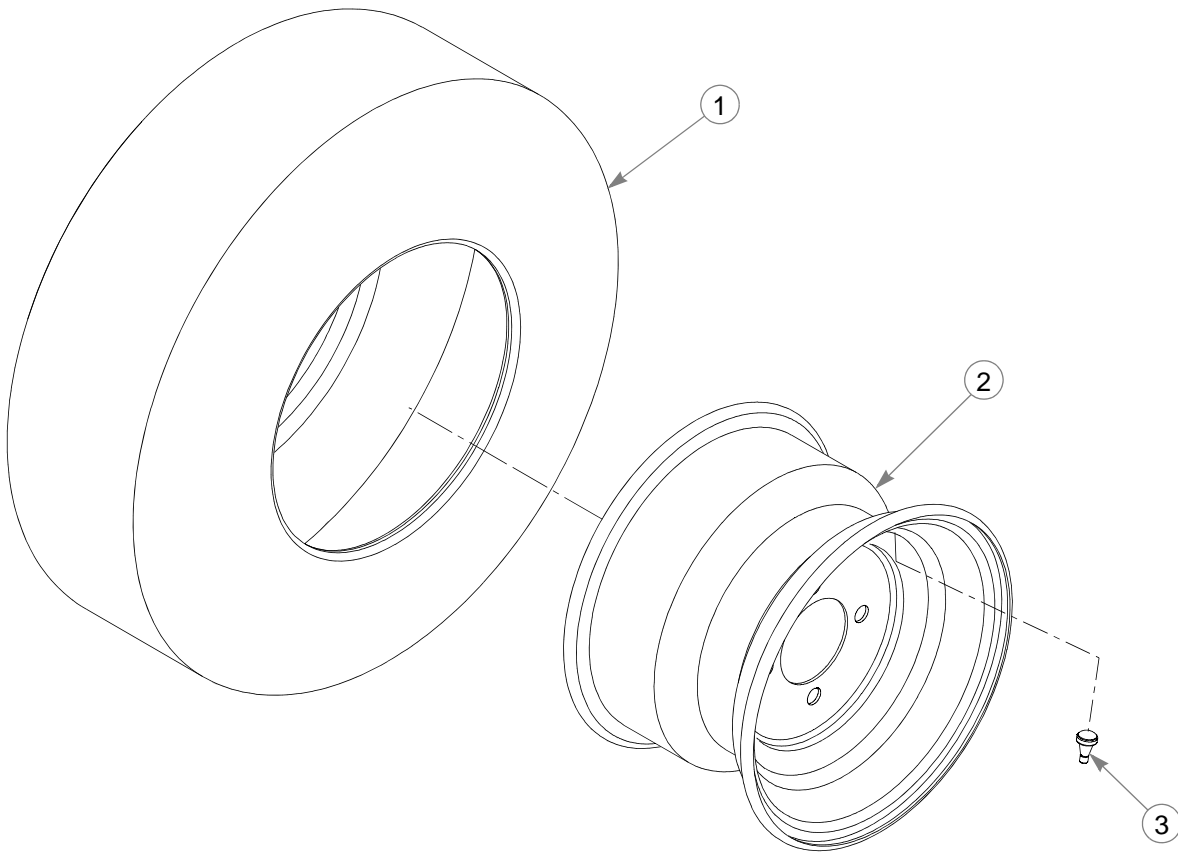

---

### **600676 TIRE/WHEEL ASSEMBLY (36" MOWER)**

<b>INDEX NO.</b>	<b>PART NO.</b>	<b>QTY.</b>	<b>DESCRIPTION</b>
1	600692	1	TIRE 20 X 8-10
2	600718	1	WHEEL
3	019521	1	TIRE VALVE

### **600668 TIRE/WHEEL ASSEMBLY (42" MOWER)**

1	600684	1	TIRE 20 X 10-10
2	600700	1	WHEEL
3	019521	1	TIRE VALVE

---

### **NOTES:**

---

## Section 5

Engine, Kawasaki FX600V—S/N 12082355 & Higher . . . . .	5-2
Engine, Kawasaki FX600V—S/N Prior to 12082355. . . . .	5-6
Engine Service Parts, Kawasaki FX600V . . . . .	5-10
Fuel System—S/N 12082355 & Higher. . . . .	5-12
EVAP System—S/N Prior to 12082355. . . . .	5-14
Fuel System—S/N Prior to 12082355 . . . . .	5-16
Fuel System Service Parts . . . . .	5-18

# Engine, Kawasaki FX600V-S/N 12082355 & Higher

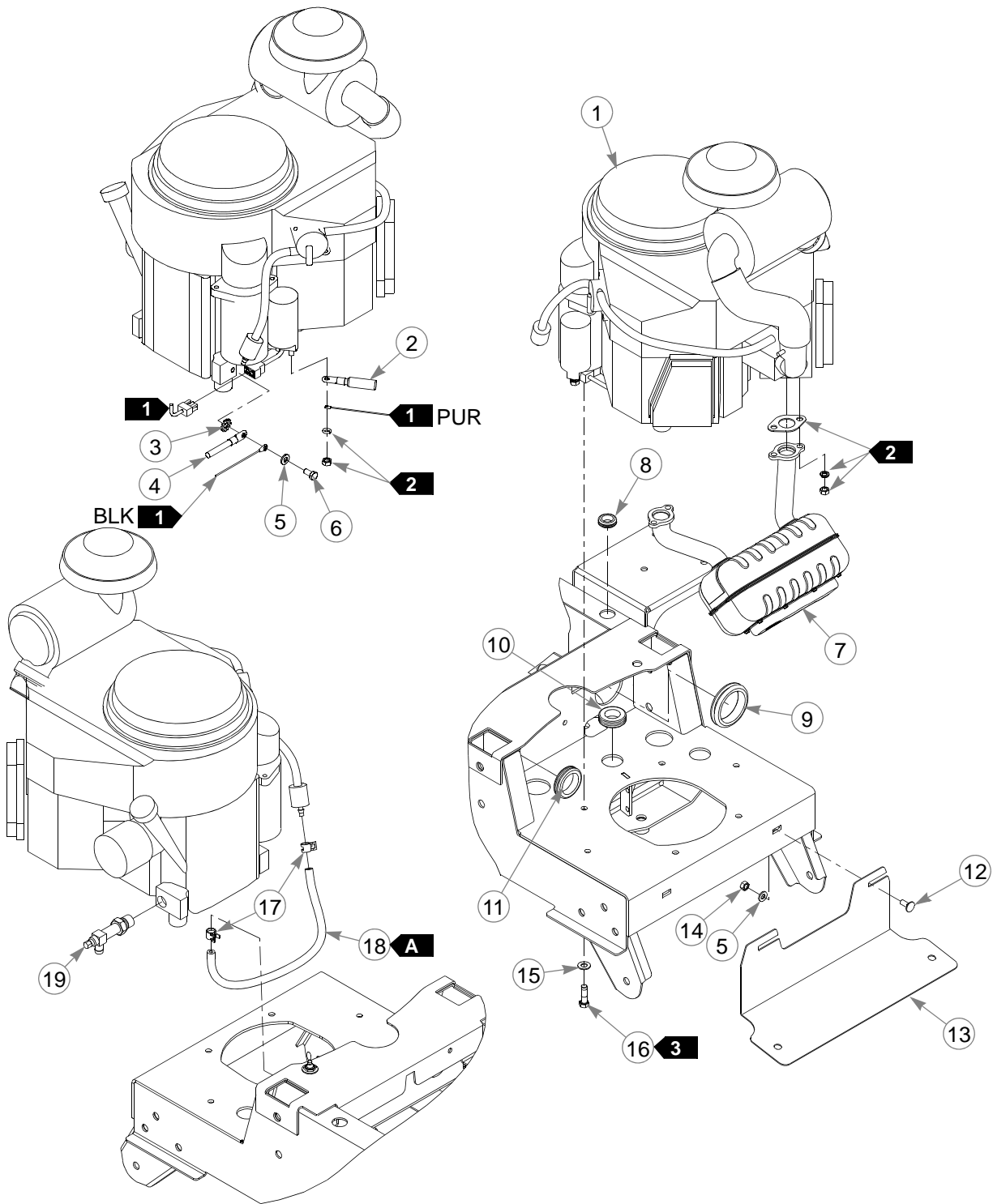

# Engine, Kawasaki FX600V–S/N 12082355 & Higher

INDEX NO.	PART NO.	QTY.	DESCRIPTION
1	N/A	1	KAWASAKI FX600V ENGINE
2	744276	1	POSITIVE BATTERY CABLE
3	029876	1	LW .312 INT-EXT TOOTH
4	744284	1	NEGATIVE BATTERY CABLE
5	768523	7	FW .343 X .687 X .051/.080H
6	720516	1	CS M8 X 1.25 X 16 HX G10.9
7	602999	1	MUFFLER
8	047456	1	GM .750 X .188 X 1.00 X .12
9	603289	1	GROMMET 2.25"
10	706531	1	GM 1.12 X 1.75 X 1.37 X .12
11	794644	1	GROMMET
12	016253	2	CB .312-18 X .75 FUL ZN
13	114648	1	MUFFLER SHIELD
14	034272	4	NT .312-18 HX G5 ZNYC
15	767954	4	FW .406 X .812 X .060 SAE
16	602580	4	CS .375-16 X 1.25 HX G5 P85
17	000323	2	HOSE CLAMP
18	015818	17"	1/4" FUEL LINE
19	796524	1	OIL DRAIN VALVE

## NOTES:

FUEL LINE LENGTHS		
	17"	FUEL FILTER TO VALVE (FUEL)

1. Part of the wire harness.
2. Supplied with the engine.
3. Torque the bolt to 30 ft-lbs. Replace (do not reuse) the cap screw if it's removed or loosened. Use only hand tools to install this fastener.

**Engine, Kawasaki FX600V-S/N 12082355 & Higher**

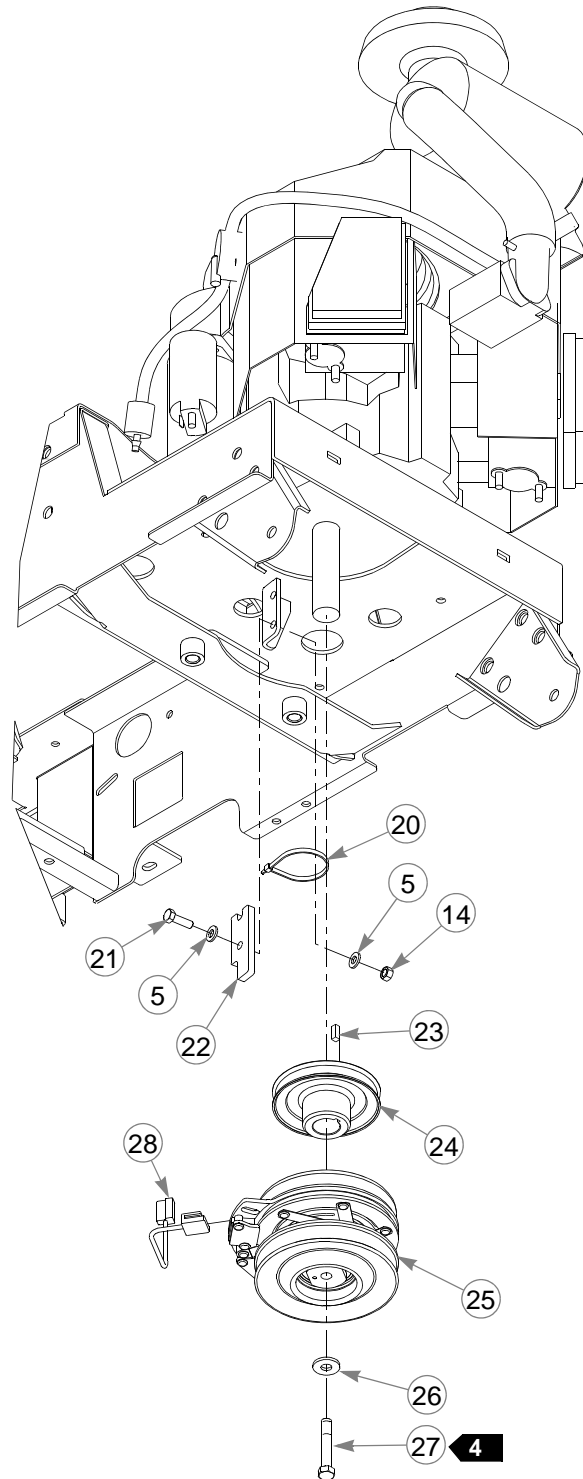

---

## **Engine, Kawasaki FX600V–S/N 12082355 & Higher**

INDEX NO.	PART NO.	QTY	DESCRIPTION
20	000331	3	WIRE TIE, SMALL/SHORT
21	036236	2	CS .312-18 X 1.00 HX G5
22	113946	1	CLUTCH ANCHOR
23	712372	1	KEY 1/4 SQ X 0.66 LG
24	603255	1	PULLEY
25	603545	1	CLUTCH (WITH HARNESS PIGTAIL)
26	602680	1	FW .453 X 1.12 X .119 HRD
27	785659	1	CS .437-20 X 2.50 HXG5 P85
28	791251	1	CLUTCH HARNESS PIGTAIL

---

### **NOTES:**

4. Torque to 45–48 ft-lbs. Replace (do not reuse) the cap screw if it's removed or loosened. Use only hand tools to install this fastener.

# Engine, Kawasaki FX600V-S/N Prior to 12082355

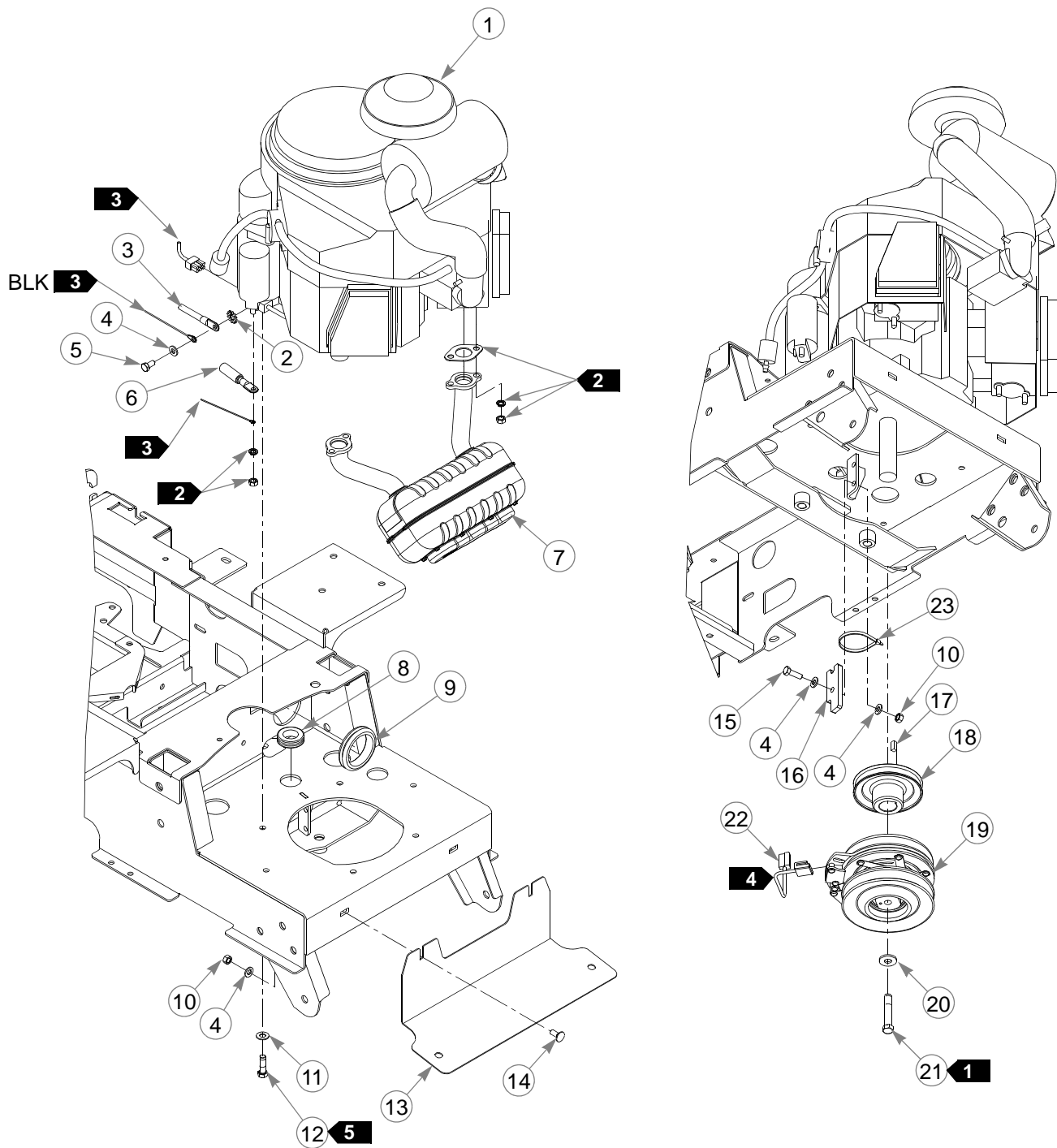



---

## **Engine, Kawasaki FX600V–S/N Prior to 12082355**

INDEX NO.	PART NO.	QTY.	DESCRIPTION
1	N/A	1	KAWASAKI FX600V ENGINE
2	029876	1	LW .312 INT-EXT TOOTH
3	744284	1	NEGATIVE BATTERY CABLE
4	768523	7	FW .343 X .687 X .051/.080H
5	720516	1	CS M8 X 1.25 X 16 HX G10.9
6	744276	1	POSITIVE BATTERY CABLE
7	602999	1	MUFFLER
8	706531	1	GM 1.12 X 1.75 X 1.37 X .12
9	603289	1	GROMMET 2.25"
10	034272	4	NT .312-18 HX G5 ZNYC
11	767954	4	FW .406 X .812 X .060 SAE
12	602580	4	CS .375-16 X 1.25 HX G5 P85
13	114648	1	MUFFLER SHIELD
14	016253	2	CB .312-18 X .75 FUL ZN
15	036236	2	CS .312-18 X 1.00 HX G5
16	113946	1	CLUTCH ANCHOR
17	712372	1	KEY 1/4 SQ X 0.66 LG
18	603255	1	PULLEY
19	603545K	1	CLUTCH KIT
20	602680	1	FW .453 X 1.12 X .119 HRD
21	785659	1	CS .437-20 X 2.50 HX G5 P85
22	791251	1	CLUTCH HARNESS PIGTAIL
23	000331	6	WIRE TIE

---

### **NOTES:**

5. Torque to 45–48 ft-lbs. Replace (do not reuse) the cap screw if it's removed or loosened. Use only hand tools to install this fastener.

**Engine, Kawasaki FX600V-S/N Prior to 12082355**

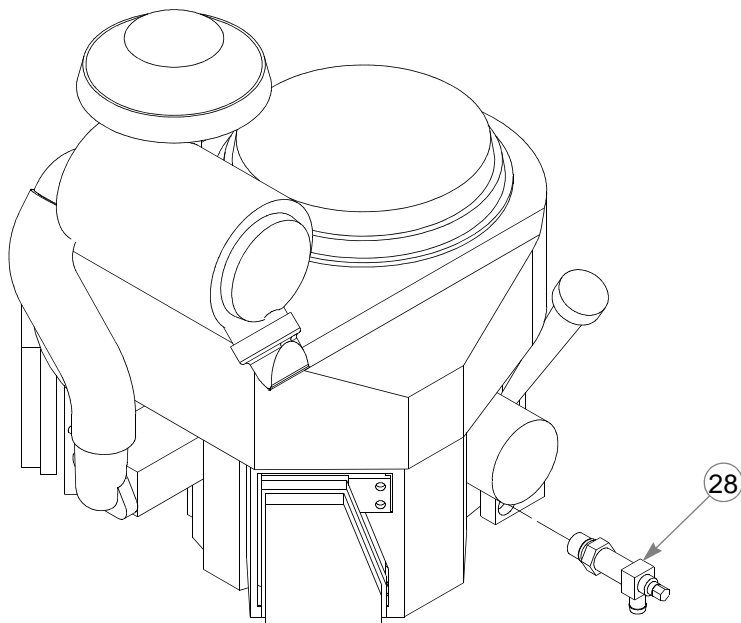
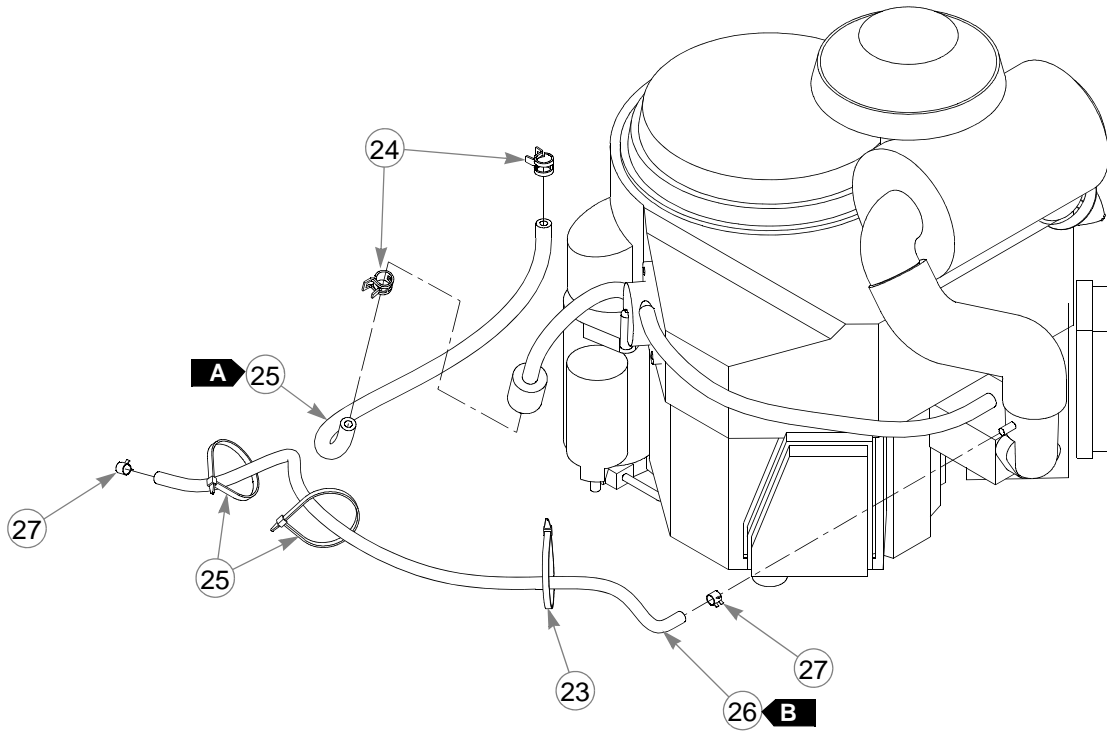

---

**Engine, Kawasaki FX600V-S/N Prior to 12082355**

INDEX NO.	PART NO.	QTY.	DESCRIPTION
24	000323	2	HOSE CLAMP
25	015818	17"	1/4" FUEL LINE
26	603326	29"	3/16" VAPOR LINE
27	603112	2	CLAMP, 3/16"
28	796524	1	OIL DRAIN VALVE

---

**NOTES:**

---

## **Engine Service Parts, Kawasaki FX600V**

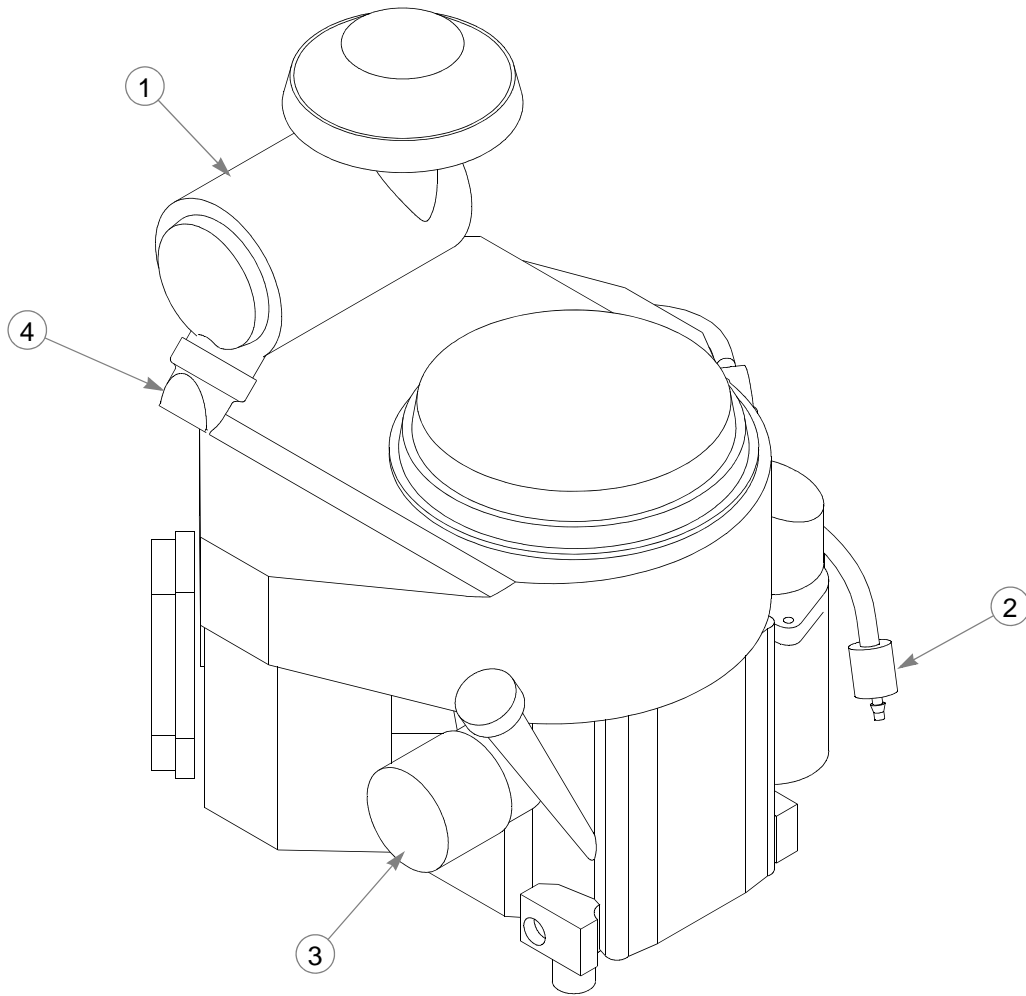

---

INDEX NO.	PART NO.	QTY.	DESCRIPTION
1	761726	1	MAIN AIR FILTER ELEMENT
2	068478	1	IN-LINE FUEL FILTER
3	602581	1	KAWASAKI ENGINE OIL FILTER
4	763318	1	VACUATOR VALVE

---

### **NOTES:**

---

**This page intentionally left blank.**



---

## **Fuel System—S/N 12082355 & Higher**

INDEX NO.	PART NO.	QTY.	DESCRIPTION
1	792978	1	LS FUEL TANK ASSEMBLY
2	792960	1	RS FUEL TANK ASSEMBLY
3	779306	2	FUEL CAP, 3.5"
4	000323	4	HOSE CLAMP
5	015818	40"	1/4" FUEL LINE
6	745059	1	FUEL VALVE 3-WAY
7	767954	6	FW .406 X .812 X .060 SAE
8	055822	6	CS .375-16 X .75 HX G5
9	781880	2	BUMPER

---

### NOTES:

1. Torque to 20 ft-lbs.

FUEL LINE LENGTHS		
<b>A</b>	28"	LEFT TANK TO VALVE (FUEL)
<b>B</b>	12"	RIGHT TANK TO VALVE (FUEL)





---

## **EVAP System—S/N Prior to 12082355**

INDEX NO.	PART NO.	QTY.	DESCRIPTION
1	015818	92"	1/4" FUEL LINE
2	000323	10	HOSE CLAMP
3	603025	1	PLASTIC TEE, 1/4"
4	047456	2	GM .750 X .188 X 1.00 X .12
5	036236	4	CS .312-18 X 1.00 HX G5
6	768523	4	FW .343 X .687 X .051/.080H
7	016832	4	NT .312-18 HXFLK ZNYC
8	000398	4	LOOP CLAMP
9	603024	1	VACUUM BREAKER

---

### NOTES:

VAPOR LINE LENGTHS		
<b>A</b>	6"	LEFT TANK TO TEE (VAPOR)
<b>B</b>	19"	TEE TO VACUUM BREAKER (VAPOR)
<b>C</b>	27"	RIGHT TANK TO VACUUM BREAKER (VAPOR)



---



## **Fuel System—S/N Prior to 12082355**

INDEX NO.	PART NO.	QTY.	DESCRIPTION
10	603088	1	LS TANK FENDER ASSEMBLY
11	603089	1	RS TANK FENDER ASSEMBLY
12	602916	2	RATCHETING GAS CAP, 3.5"
13	745059	1	FUEL VALVE 3-WAY
14	767954	6	FW .406 X .812 X .060 SAE
15	055822	6	CS .375-16 X .75 HX G5
16	781880	2	BUMPER

---

### **NOTES:**

1. Torque to 20 ft-lbs.

<b>FUEL LINE LENGTHS</b>		
<b>D</b> 	28"	LEFT TANK TO VALVE (FUEL)
<b>E</b> 	12"	RIGHT TANK TO VALVE (FUEL)

# **Fuel System Service Parts**

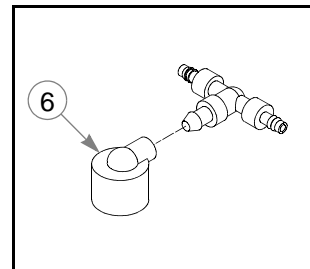
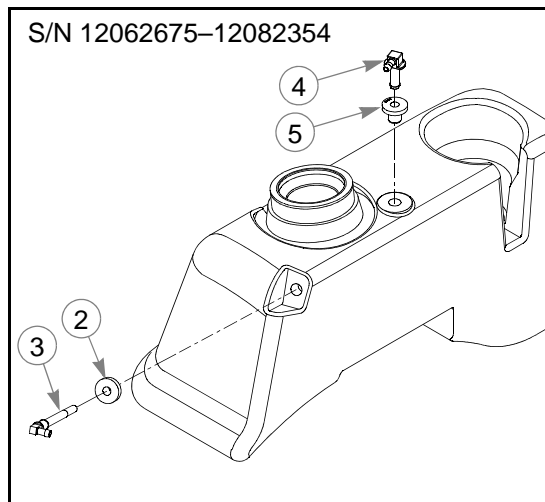
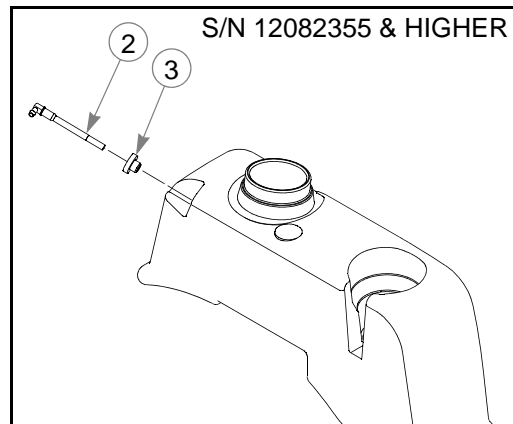
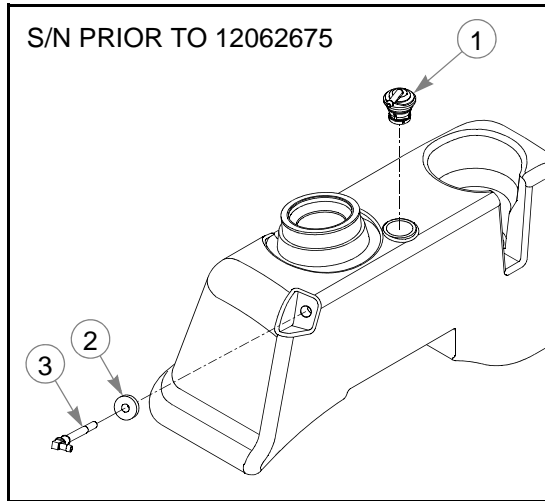

INDEX NO.	PART NO.	QTY.	DESCRIPTION
1	117118	1	VENT FITTING KIT
2	785295	1	SUCTION HOSE GROMMET
3	601527	1	SUCTION HOSE ASSY 19.5"
4	604199	1	FUEL VENT VALVE
5	604200	1	GROMMET
6	603161	1	VACUUM BREAKER FILTER

## **NOTES:**

---

## Section 6

Battery . . . . .	6-2
Instrument Panel . . . . .	6-4

# Battery

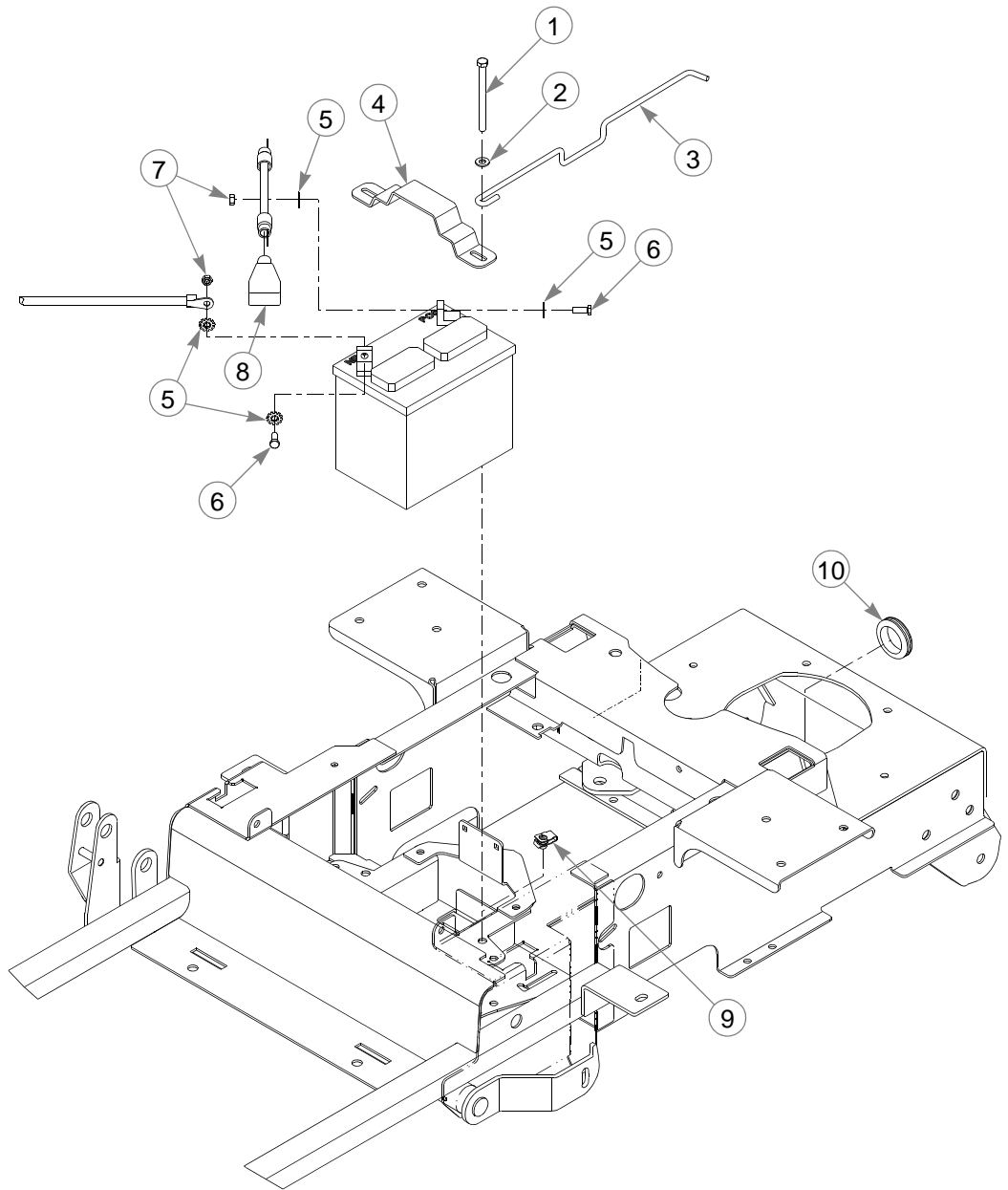

---

# **Battery**

INDEX NO.	PART NO.	QTY.	DESCRIPTION
1	714618	2	CS .312-18 X 4.00 HX G5
2	768523	2	FW .343 X .687 X .051/.080H
3	601212	1	BATTERY CABLE SUPPORT
4	348417	1	BATTERY CLAMP STRAP
5	029868	4	LW .250 INT-EXT TOOTH Z
6	055939	2	CS .250-20 X .75 HX G5
7	024927	2	NT .250-20 HX G5 ZNYC
8	771428	1	RED BATTERY CABLE BOOT
9	601069	2	CN .312-18 X .20 MAX THK
10	794644	1	GROMMET
11	000331	1	WIRE TIE (NOT SHOWN)

---

## **NOTES:**

# Instrument Panel

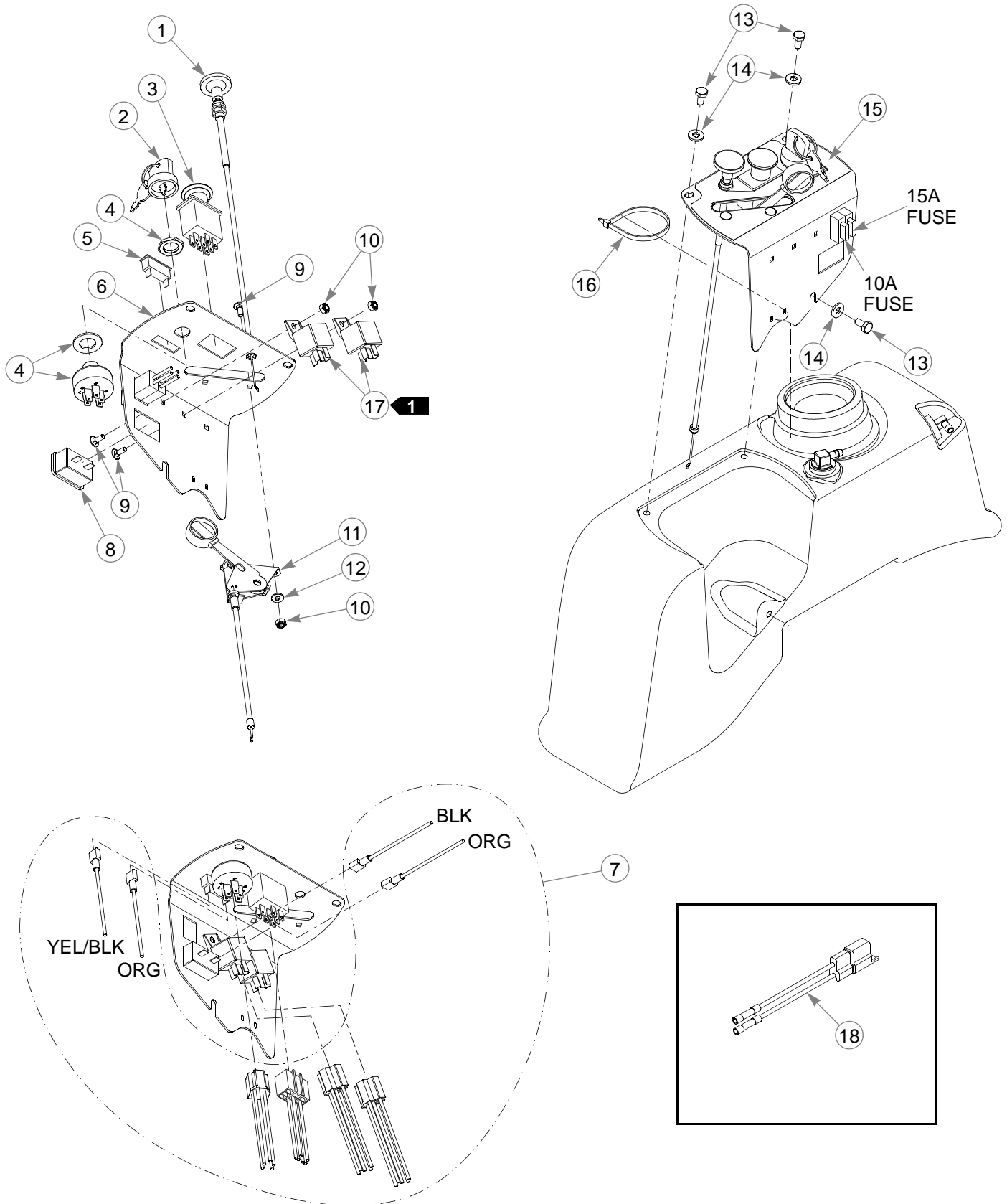



---

## **Instrument Panel**

INDEX NO.	PART NO.	QTY.	DESCRIPTION
1	786657	1	CHOKE CABLE
2	785808	1	KEY ASSEMBLY
3	776476	1	PTO SWITCH
4	045898	1	IGNITION SWITCH
5	712257	1	RED INDICATOR LIGHT
6	550446	1	INSTRUMENT PANEL (WITH DECAL)
7	603334	1	WIRE HARNESS
8	769166	1	HOUR METER
9	601098	4	CB 10-24 X .500 ZYNC
10	059832	4	NT #10-24 HX NL ZN
11	778365	1	THROTTLE CABLE
12	704932	2	FW .219 X .500 X .048 ZNYC
13	055947	3	CS .250-20 X .500 HX G5
14	768515	3	FW .281 X .625 X .051/.080 HD ZN/YL
15	602468	1	INSTRUMENT PANEL DECAL
16	000331	3	WIRE TIE
17	601053	2	SEALED RELAY (WITH BRACKET)
18	114052	1	CLUTCH CONNECTOR REPAIR KIT

---

### **NOTES:**

1. Part of the wire harness.



---

## Section 7

36" Service Deck . . . . .	7-2
36" Deck Pulleys & Spindles . . . . .	7-4
36" Deck . . . . .	7-6
42" Service Deck . . . . .	7-8
42" Deck Pulleys & Spindles . . . . .	7-10
42" Deck . . . . .	7-12
Deck Lift. . . . .	7-14
Deck Mounting Hardware . . . . .	7-16

# **36" Service Deck**

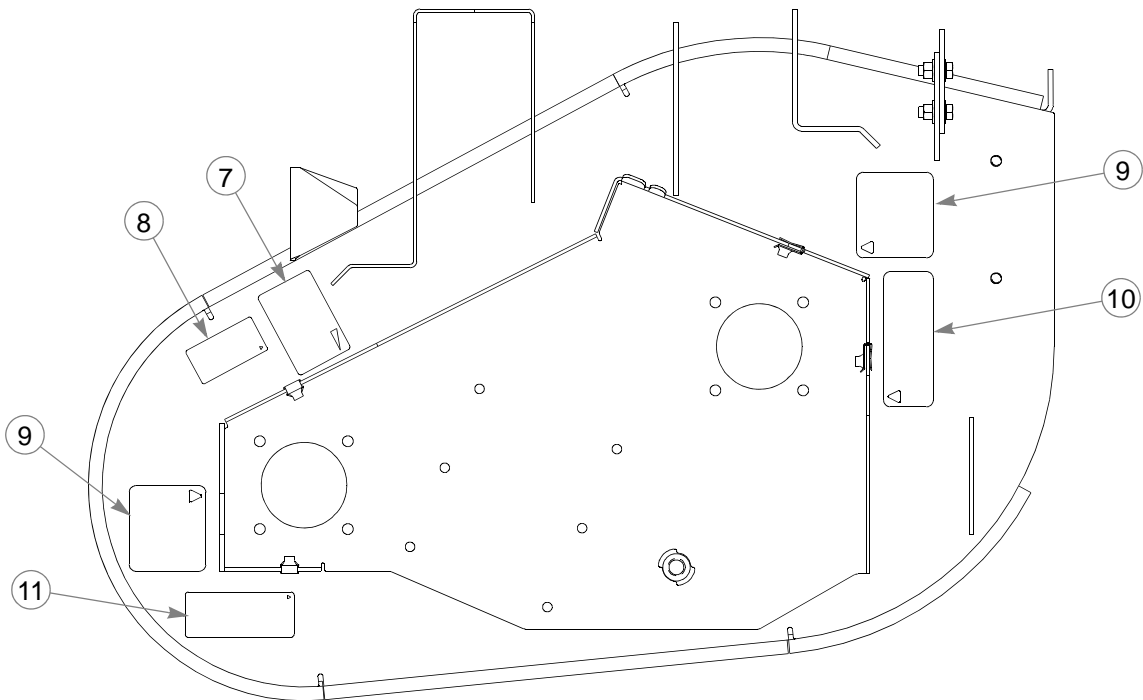
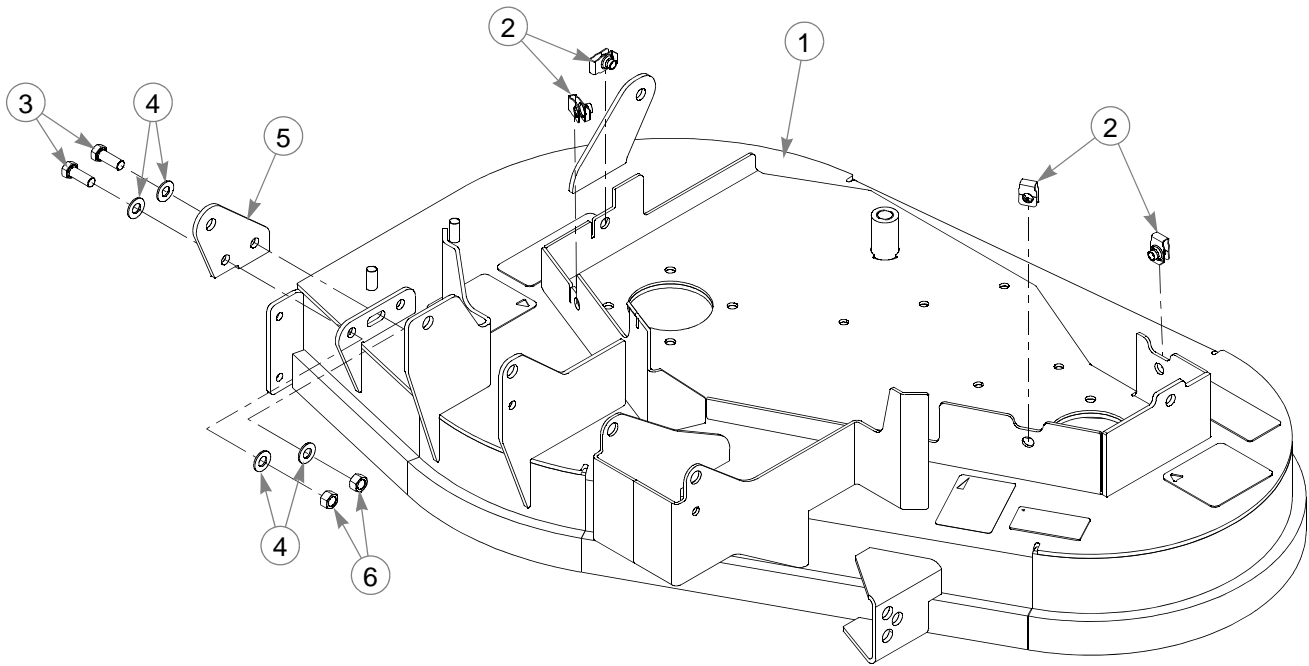

---

## **36" Service Deck**

INDEX NO.	PART NO.	QTY	DESCRIPTION
1	550956	1	36" DECK (WITH DECALS & HARDWARE)
2	601069	4	CN .312-18X.200 MAX THK
3	036244	2	CS .375-16 X 1.000 HX G5
4	767954	4	FW .406 X .812 X.060 SAE
5	114645	2	HANGER
6	054502	2	NT .375-16 HX GRD 5 ZNY
7	603548	1	BELT ROUTING DECAL
8	793513	1	36" DECK ID DECAL
9	601837	2	DECK DANGERS DECAL
10	601624	1	DISCHARGE CHUTE DECAL
11	601892	1	THROWN OBJECTS DECAL

---

### **NOTES:**

# 36" Deck Pulleys & Spindles

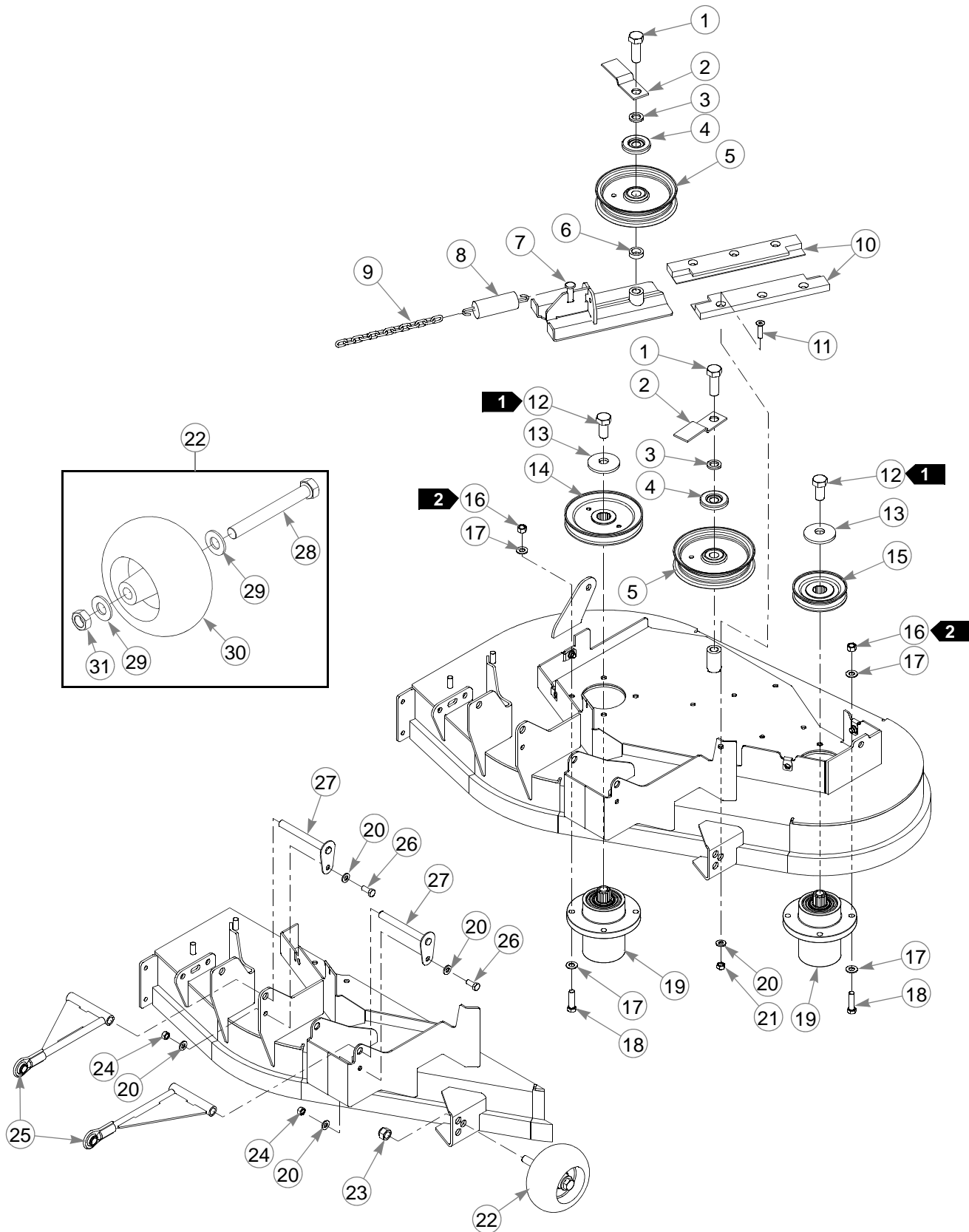

---

## **36" Deck Pulleys & Spindles**

INDEX NO.	PART NO.	QTY.	DESCRIPTION
1	025007	2	CS .625-11 X 1.750 HX G5
2	347443	2	DECK BELT IDLER GUIDE
3	028118	2	FW .625 X 1.00 X .134 ZNYC
4	603057	2	DUST SHIELD WITH OFFSET
5	781856	2	IDLER PULLEY, NHI 5.0"
6	600296	1	DECK IDLER SPACER
7	114433	1	IDLER SLIDE
8	036384	1	SPRING 1/4 COIL PL 1.23
9	259812	1	CHAIN
10	601434	2	UHMW IDLER SLIDE
11	784199	6	CS .312-18 X 1.250 FLT SH
12	781872	2	CS .625-11 X 1.25 HX G5 Z
13	782474	2	CW .631 X 2.250 X .187 PNT
14	796656	1	PULLEY, 5.62 EOD, A-SEC
15	796664	1	PULLEY, 3.75 EOD, A-SEC
16	054502	8	NT .375-16 HX GRD 5 ZNY
17	767954	16	FW .406 X .812 X .060 SAE
18	005116	8	CS .375-16 X 1.375 HX G5
19	783506	2	BLADE SPINDLE
20	768523	10	FW .343 X .687 X .051/.080H
21	058776	6	NT .312-18 HXZY NL
22	788166	1	ANTI-SCALP WHEEL (WITH HARDWARE)
23	781567	1	NT .500-13 HX G8 ZY NL
24	034272	2	NT .312-18 HX G5 ZNYC
25	797365	2	DECK PULLBAR
26	034280	2	CS .312-18 X .750 HX G5
27	322974	2	PULLBAR PIN
28	781708	1	CS .500-13 X 4.250 HX G5
29	767962	2	FW .531 X 1.063 X .090 SAE
30	031997	1	ANTI-SCALP WHEEL
31	053199	1	NT .500-13 HX JAM ZNYC

---

### **NOTES:**

1. Torque to 118 ft-lbs.
2. Torque to 30 ft-lbs.

# 36" Deck

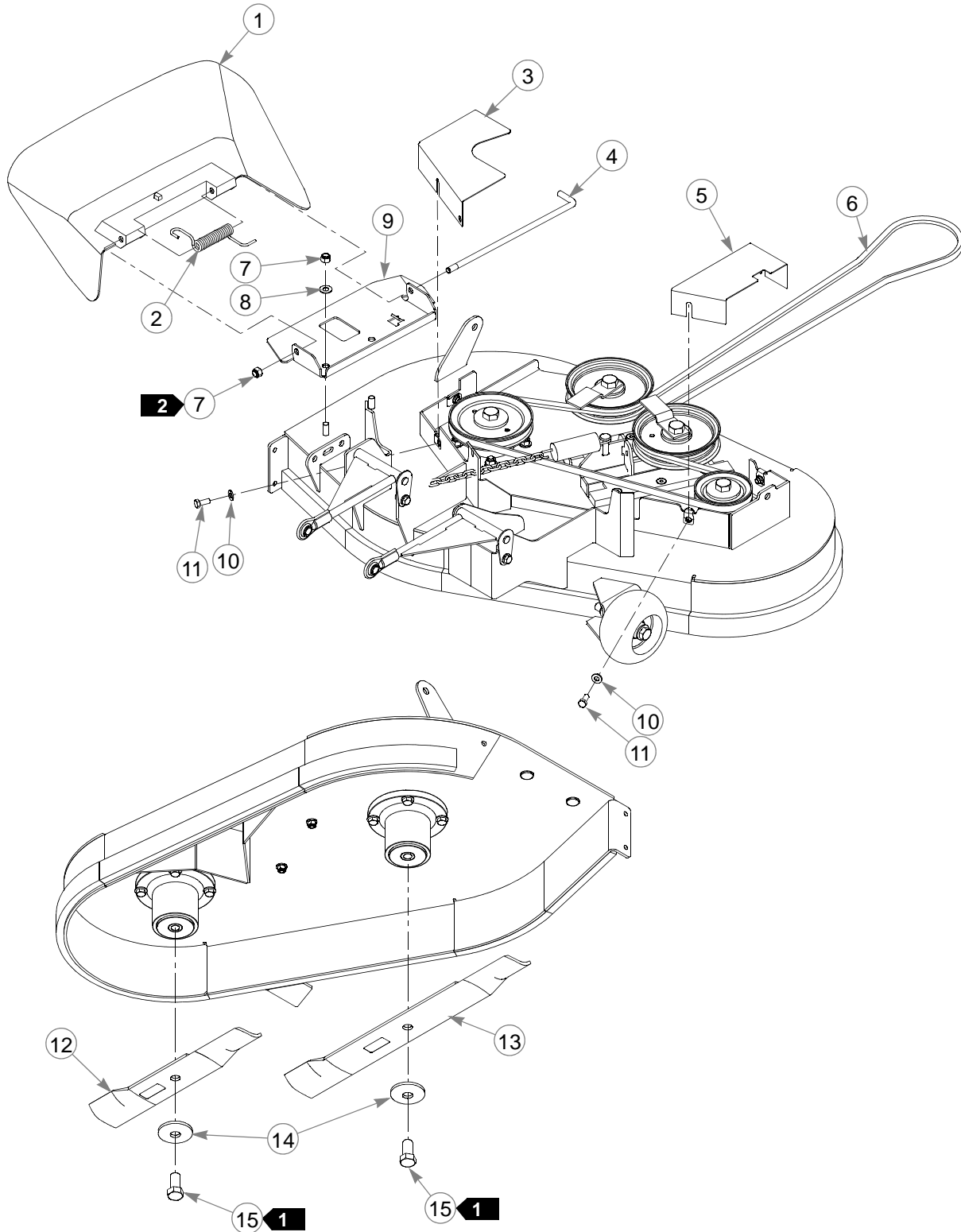



---

## **36" Deck**

INDEX NO.	PART NO.	QTY.	DESCRIPTION
1	601806	1	DISCHARGE CHUTE
2	601824	1	TORSION SPRING
3	100875	1	RS PULLEY COVER
4	601843	1	CHUTE PIN
5	100867	1	LS PULLEY COVER
6	600726	1	BELT, A 114.3" EL
7	086660	3	NT .375-16 HXZY NL
8	767954	2	FW .406 X .812 X .060 SAE
9	112877	1	CHUTE BRACKET
10	768523	4	FW .343 X .687 X .051/.080H
11	034280	4	CS .312-18 X .750 HX G5
12	600900	1	BLADE, F13.75"-L-F-CW
	794206	1	BLADE, 13.75"-MUL-F-CW
	794222		BLADE, 13.75"-GAT-F-CW
13	600901	1	BLADE, F20.50"-L-F-CW
	793935	1	BLADE, 20.50"-CAT-F-CW
	794214	1	BLADE, 20.50"-MUL-F-CW
	794230	1	BLADE, 20.50"-GAT-F-CW
14	782474	2	CW .631 X 2.250 X .187 PNT
15	781872	2	CS .625-11 X 1.25 HX G5 Z

---

### **NOTES:**

1. Torque to 118 ft-lbs.
2. Do not torque the nut; the discharge chute must pivot freely.

# **42" Service Deck**

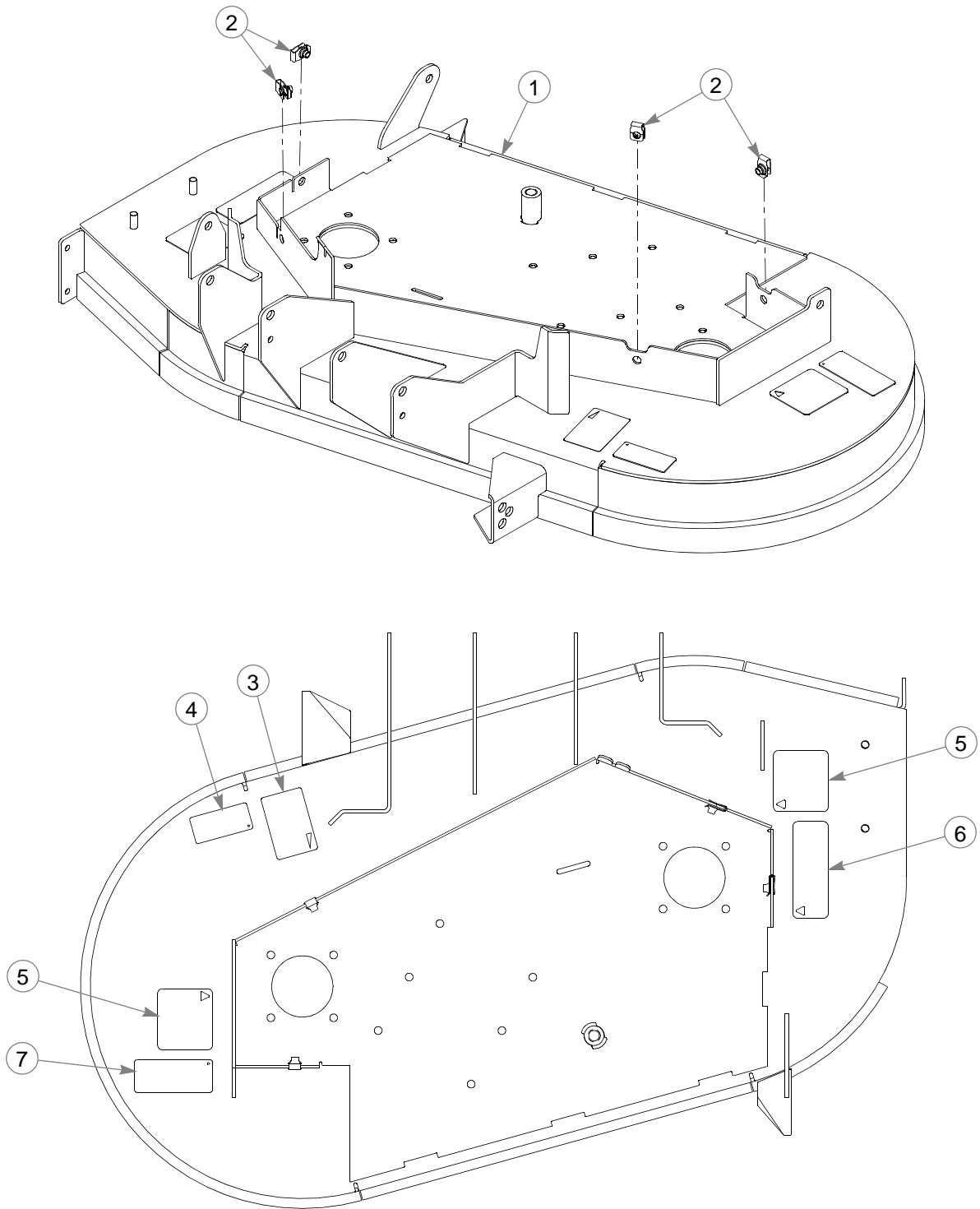

---

## **42" Service Deck**

INDEX NO.	PART NO.	QTY.	DESCRIPTION
1	550957	1	42" DECK (WITH DECALS & HARDWARE)
2	601069	4	CN .312-18 X .20 MAX THK
3	603548	1	BELT ROUTING DECAL
4	793521	1	42" DECK ID DECAL
5	601837	2	DECK DANGERS DECAL
6	601624	1	DISCHARGE CHUTE DECAL
7	601892	1	THROWN OBJECTS DECAL

---

**NOTES:**

# 42" Deck Pulleys & Spindles

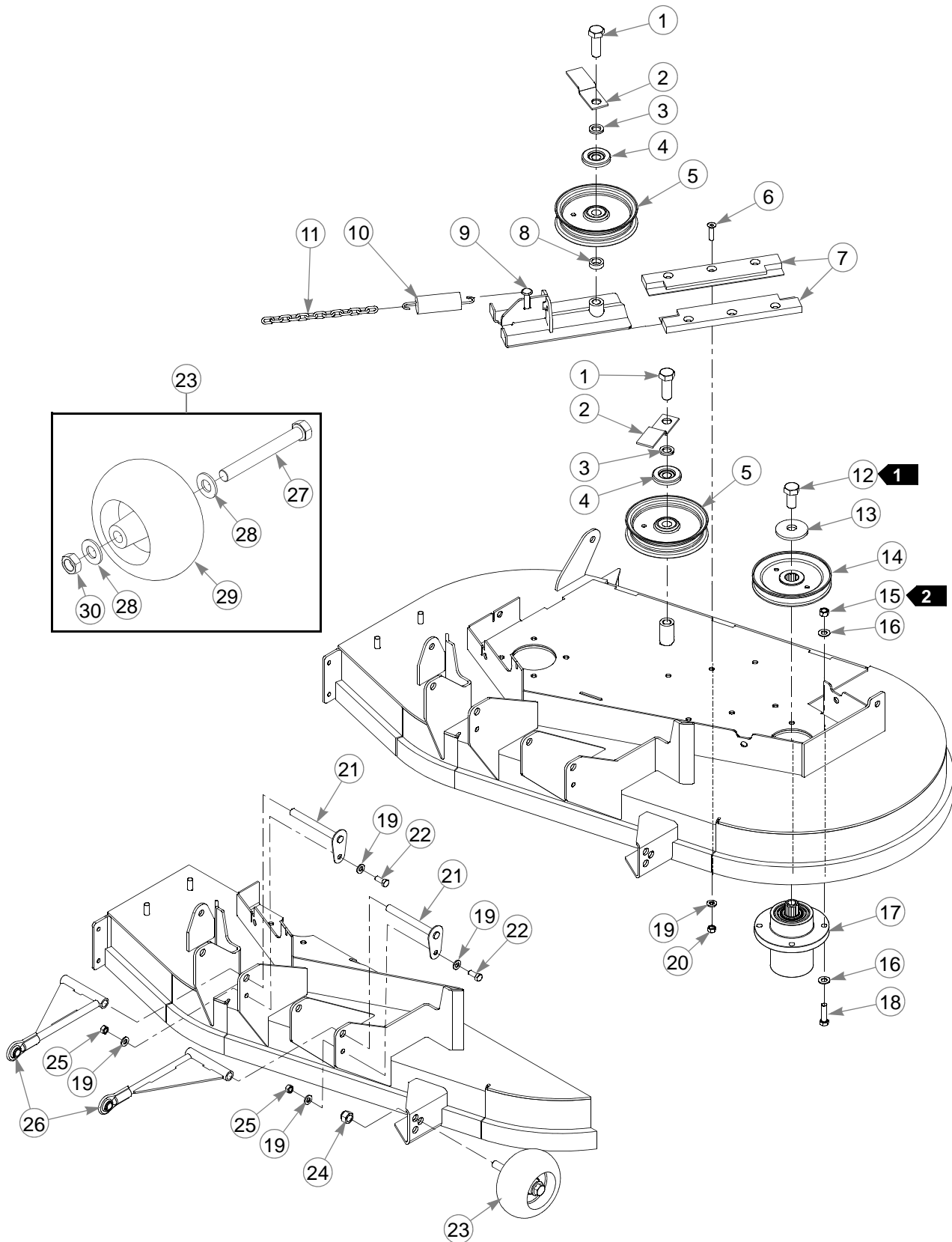

---

## **42" Deck Pulleys & Spindles**

INDEX NO.	PART NO.	QTY.	DESCRIPTION
1	025007	2	CS .625-11 X 1.750 HX G5
2	347443	2	DECK BELT IDLER GUIDE
3	028118	2	FW .625 X 1.00 X .134 ZNYC
4	603057	2	DUST SHIELD WITH OFFSET
5	781856	2	IDLER PULLEY, NHI 5.0"
6	784199	6	CS .312-18 X 1.250 FLT SH
7	601434	2	UHMW IDLER SLIDE
8	600296	1	DECK IDLER SPACER
9	114433	1	IDLER SLIDE
10	036384	1	TENSION SPRING
11	259812	1	CHAIN, 13 LINK
12	781872	2	CS .625-11 X 1.25 HX G5 Z
13	782474	2	CW .631 X 2.250 X .187 PNT
14	796656	2	PULLEY, 5.62 EOD, A-SEC
15	054502	8	NT .375-16 HX GRD 5 ZNY
16	767954	16	FW .406 X .812 X .060 SAE
17	783506	2	BLADE SPINDLE
18	005116	8	CS .375-16 X 1.375 HX G5
19	768523	10	FW .343 X .687 X .051/.080H
20	058776	6	NT .312-18 HXZY NL
21	322974	2	PULLBAR PIN
22	034280	2	CS .312-18 X .750 HX G5
23	788166	2	ANTI-SCALP WHEEL (WITH HARDWARE)
24	781567	2	NT .500-13 HX G8 ZY NL
25	034272	2	NT .312-18 HX G5 ZNYC
26	797365	2	DECK PULLBAR
27	781708	1	CS .500-13 X 4.250 HX G5
28	767962	2	FW .531 X 1.063 X .090 SAE
29	031997	1	ANTI-SCALP WHEEL
30	053199	1	NT .500-13 HX JAM ZNYC

---

### **NOTES:**

1. Torque to 118 ft-lbs.
2. Torque to 30 ft-lbs.

# 42" Deck

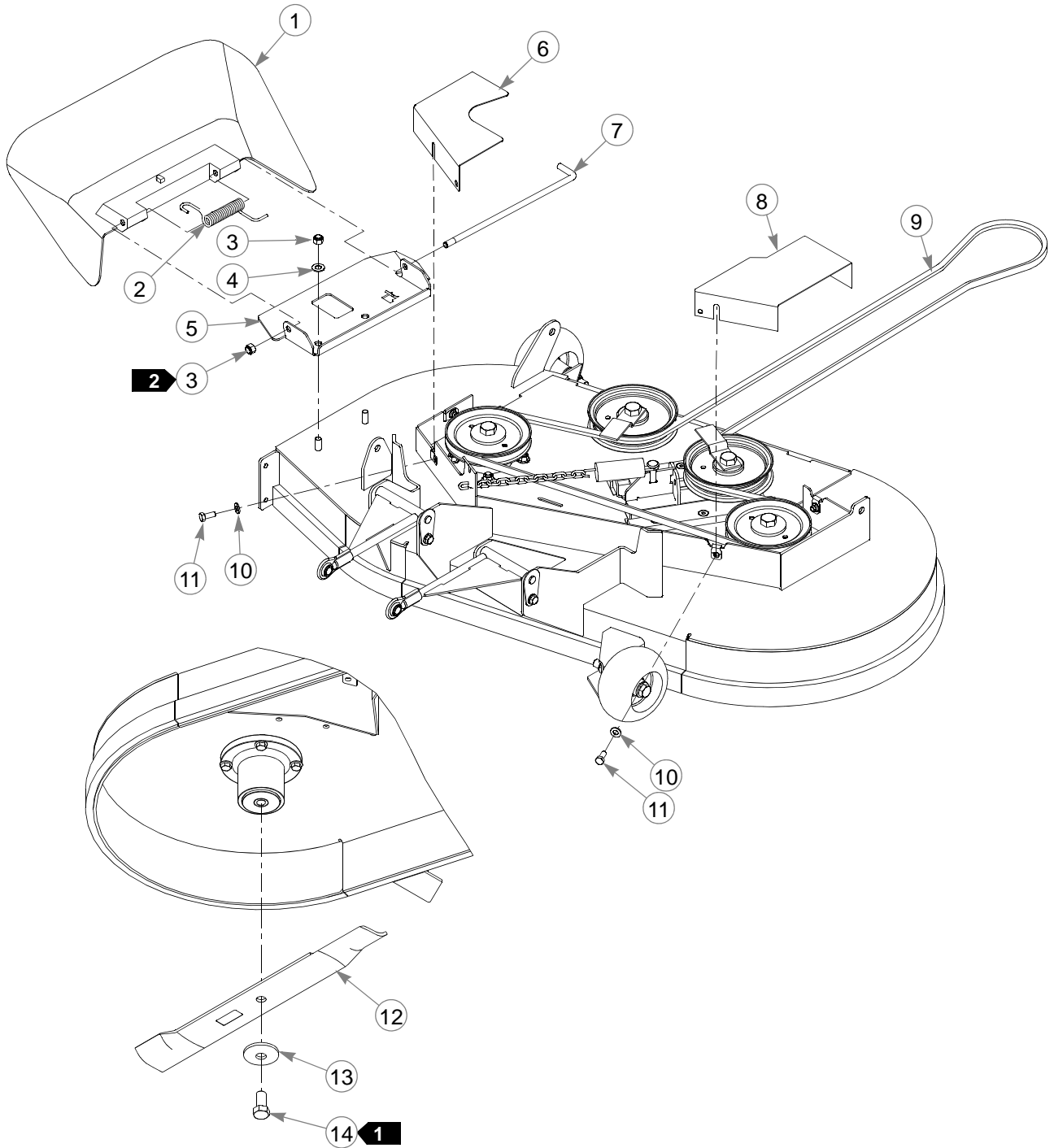

---

## **42" Deck**

INDEX NO.	PART NO.	QTY.	DESCRIPTION
1	601806	1	DISCHARGE CHUTE
2	601824	1	TORSION SPRING
3	086660	3	NT .375-16 HXZY NL
4	767954	2	FW .406 X .812 X .060 SAE
5	112877	1	CHUTE BRACKET
6	100875	1	RS PULLEY COVER
7	601843	1	CHUTE PIN
8	105155	1	LS PULLEY COVER
9	793893	1	BELT, A 127.3" EL
10	768523	4	FW .343 X .687 X .051/.080H
11	034280	4	CS .312-18 X .750 HX G5
12	600901	2	BLADE, F20.50"-L-F-CW
	793935	2	BLADE, 20.50"-CAT-F-CW
	794230	2	BLADE, 20.50"-GAT-F-CW
	794214	2	BLADE, 20.50"-MUL-F-CW
13	782474	2	CW .631 2.250 X .187 PNT
14	781872	2	CS .625-11 X 1.25 HX G5 ZN

---

### **NOTES:**

1. Torque to 118 ft-lbs.
2. Do not torque the nut; the discharge chute must pivot freely.

# Deck Lift

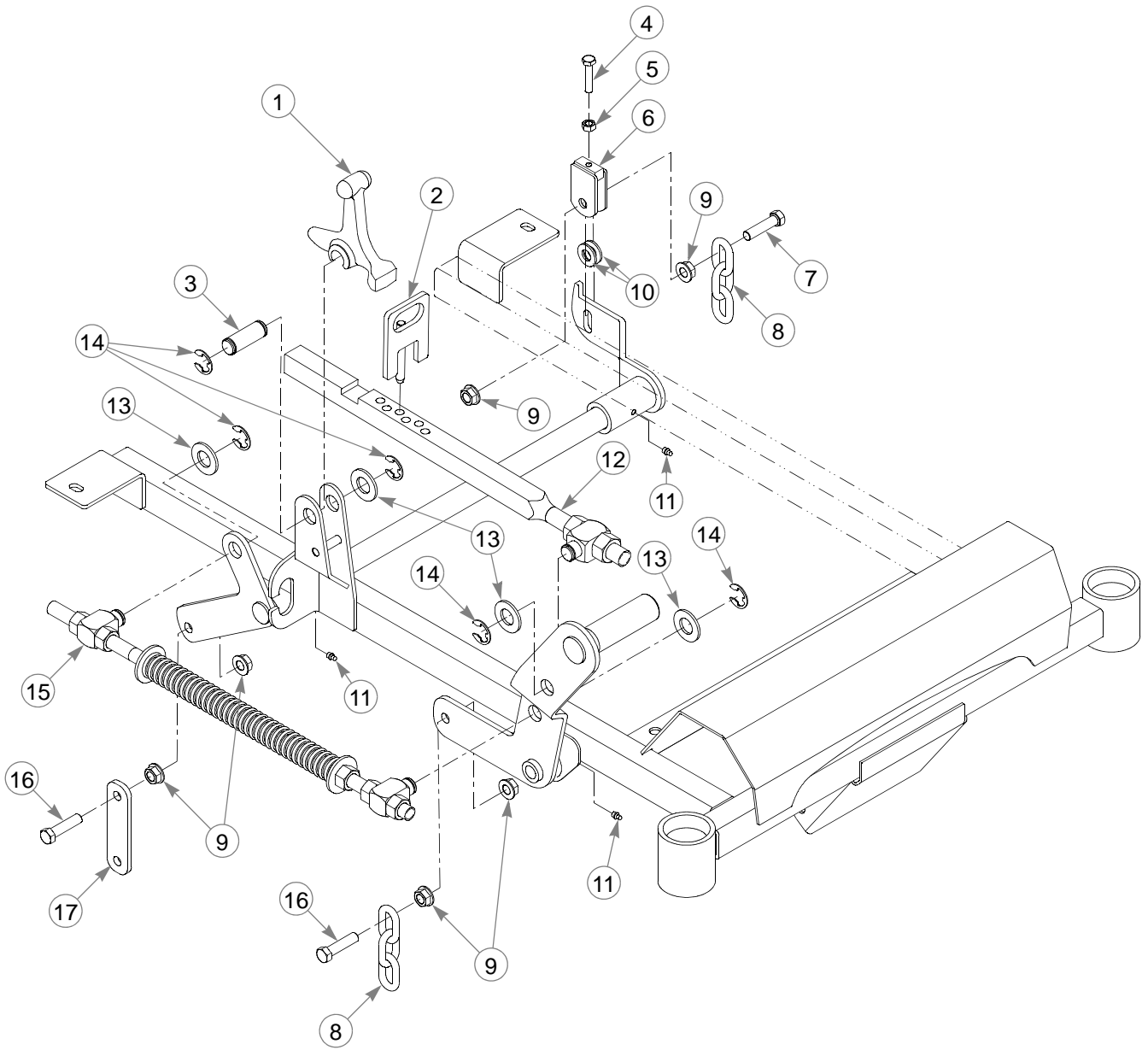



---

## **Deck Lift**

INDEX NO.	PART NO.	QTY.	DESCRIPTION
1	348318	1	STOP HANDLE
2	348284	1	HEIGHT ADJ STOP
3	781229	1	CE .750 X 2.25 X 1.75 HEAD
4	756270	1	CS .312-18 X 1.50 FLTHR G
5	034272	1	NT .312-18 HX G5 ZNYC
6	348458	1	DECK LEVELER YOKE
7	781831	1	CS .437-14 X 1.750 FULTH
8	360131	2	DECK LIFT CHAIN
9	704643	12	NT .437-14 HX FLG ZN
10	767962	6	FW .531 X 1.063 X .090 SAE
11	015495	3	GREASE FITTING STRAIGHT
12	784488	1	DECK LIFT INDICATOR
13	601681	4	FW .781 X 1.50 X .120 ZNYC
14	781294	5	E CLIP 1.00 X .625 X .05
15	782995	1	DECK LIFT SPRING
16	055749	5	CS .437-14 X 1.750 HX G5
17	334045	1	DECK LIFT LINK

---

### **NOTES:**

# Deck Mounting Hardware

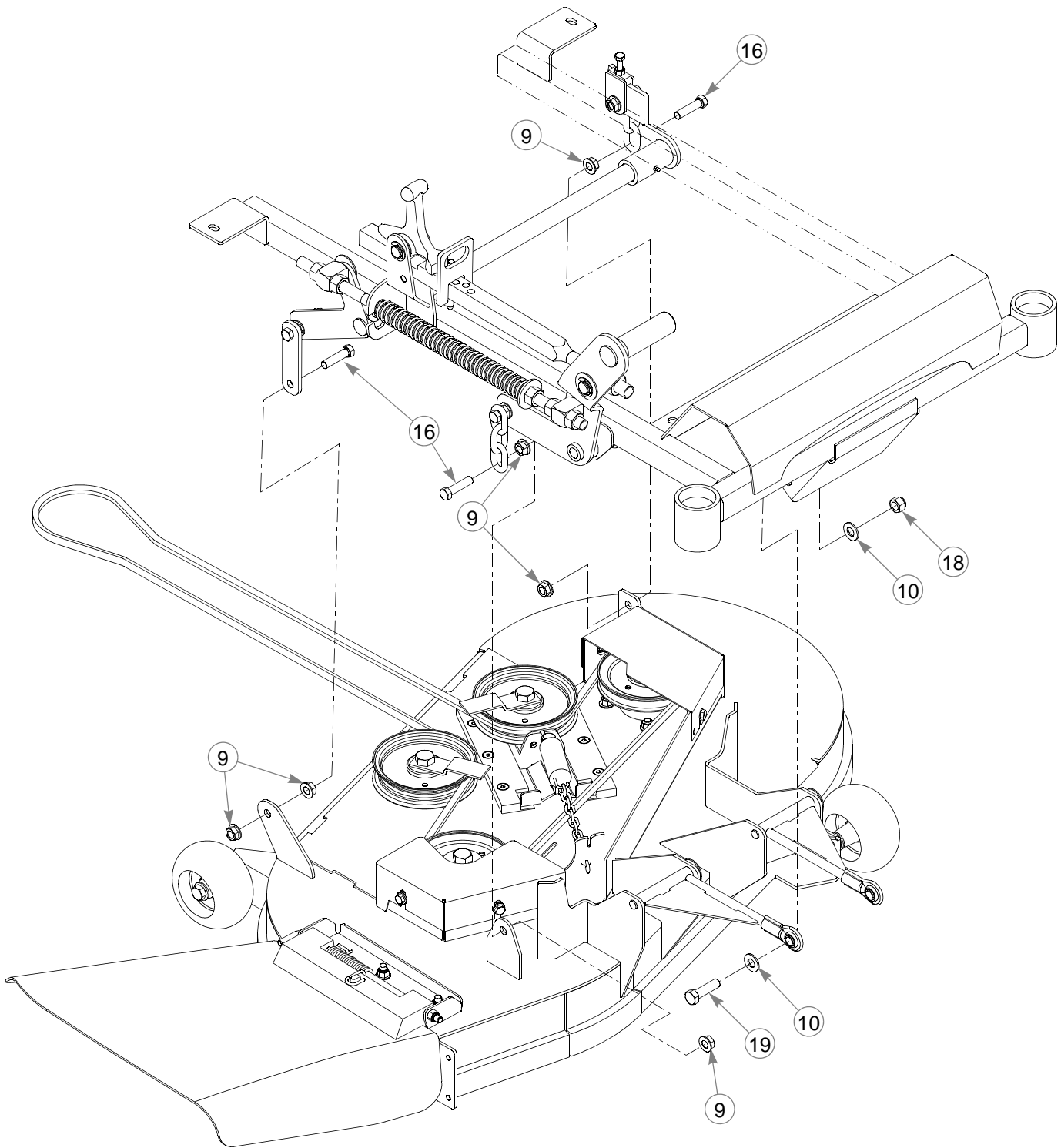

---

## **Deck Mounting Hardware**

INDEX NO.	PART NO.	QTY.	DESCRIPTION
18	781567	2	NT .500-13 HX G8 ZY NL
19	017616	2	CS .500-13 X 1.750 HX G5

---

### **NOTES:**



---

## Section 8

Seat .....	8-2
ROPS.....	8-6

# Seat

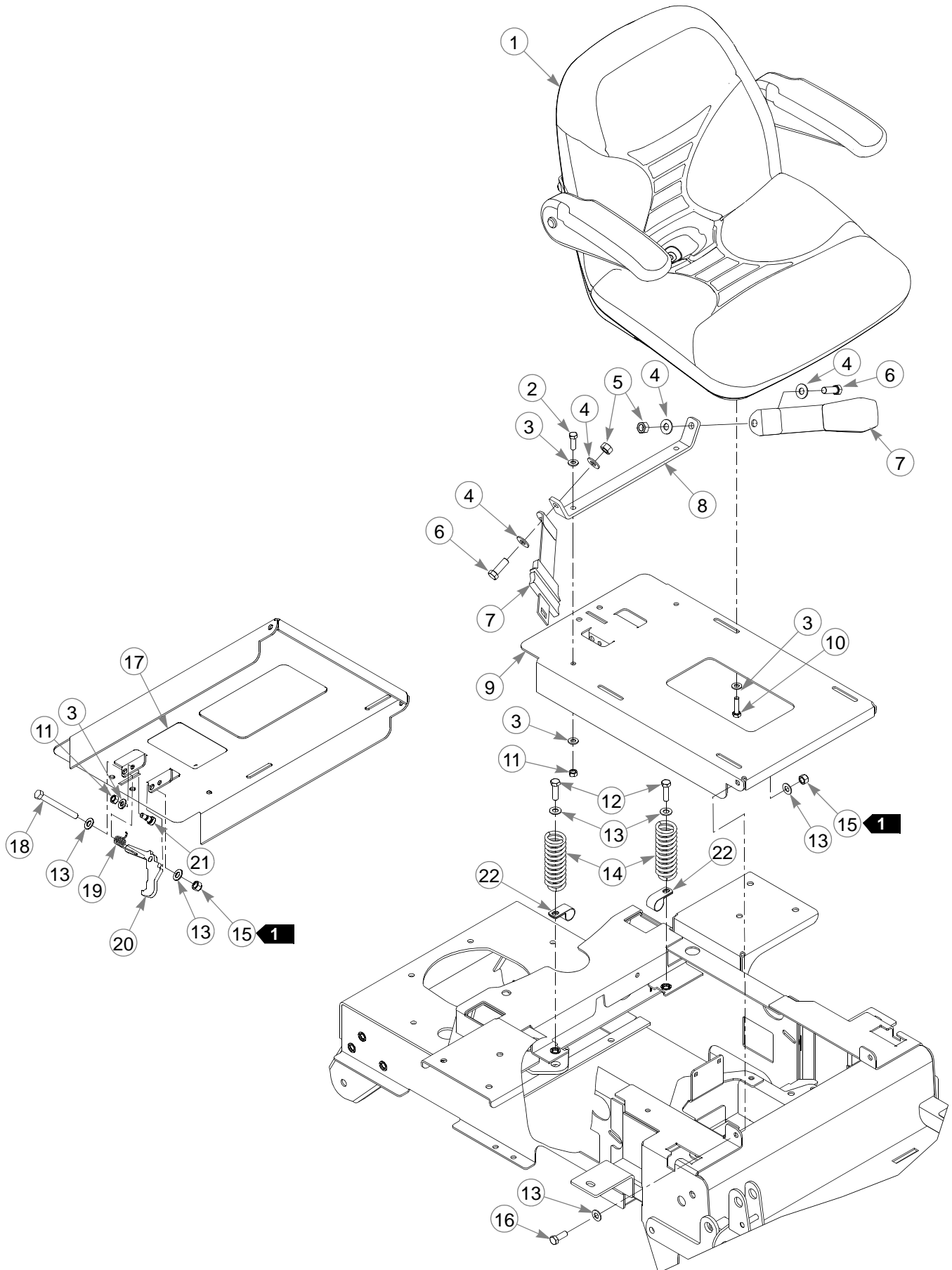

---

# Seat

INDEX NO.	PART NO.	QTY.	DESCRIPTION
1	792226	1	SEAT, STANDARD
2	036236	2	CS .312-18 X 1.000 HX G5
3	768523	9	FW .343 X .687 X .051/.080H
4	017129	4	FW .440 X 1.000 X .083 ZNY
5	704635	2	NT .437-20 HX GR5 ZNYC
6	754101	2	CS .437-20 X 1.250 G5 ZNY
7	603489	1	SEAT BELT
8	114641	1	SEAT BELT CROSS BAR
9	551088	1	SEAT PAN (WITH DECALS)
10	079186	4	CS .312-18 X 1.25 HX G5
11	034272	3	NT .312-18 HX G5 ZNYC
12	052860	2	CS .375-16 X 1.25 HX G5
13	767954	8	FW .406 X .812 X .060 SAE
14	601450	2	SEAT SPRING 150 LB/IN
15	086660	3	NT .375-16 HXZY NL
16	036244	2	CS .375-16 X 1.000 HX G5
17	601815	1	BATTERY WARNINGS DECAL
18	005108	1	CS .375-16 X 3.50 HX G5 Z
19	783910	1	TORSION SPRING
20	603101	1	SEAT LATCH
21	754358	1	SB .375 X .375 SH .312-18
22	043570	2	HOSE CLAMP

---

## NOTES:

1. Do not torque; the seat pan and seat latch must pivot freely.

# Seat Service Parts

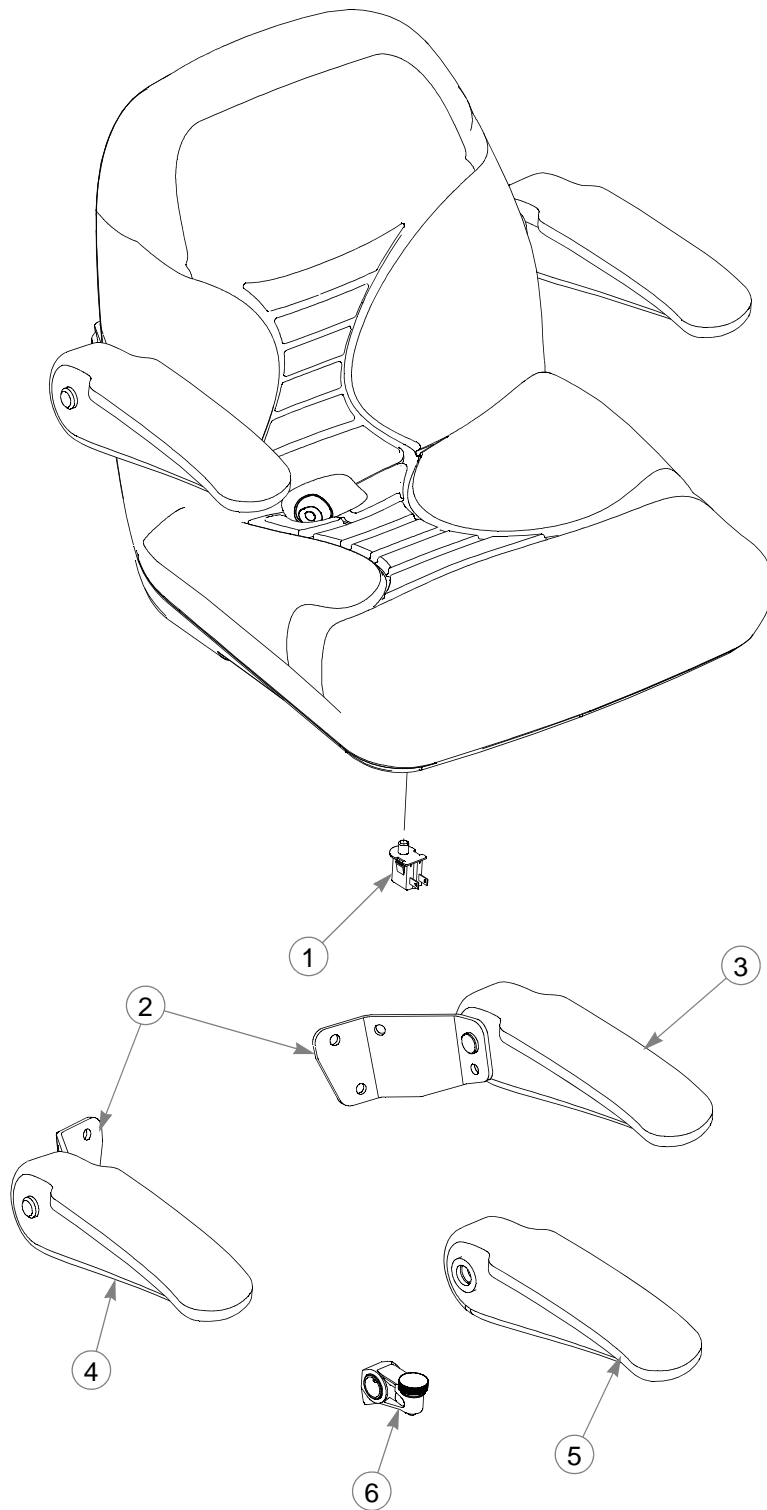



---

## **Seat Service Parts**

<b>INDEX NO.</b>	<b>PART NO.</b>	<b>QTY.</b>	<b>DESCRIPTION</b>
1	793315	1	SEAT SWITCH
2	797456	1	ARMREST KIT ROUND
3	797464	1	LS ARMREST ASSEMBLY, ROUND (WITH BRACKET)
	604458	1	LS ARMREST KIT (PLASTIC BACK SEATS)
4	797472	1	RS ARMREST ASSEMBLY, ROUND (WITH BRACKET)
	604459	1	RS ARMREST KIT (PLASTIC BACK SEATS)
5	797480	1	MOLDED ROUND ARMREST
6	793273	1	ARMREST STOP ASSEMBLY

---

### **NOTES:**

# ROPS

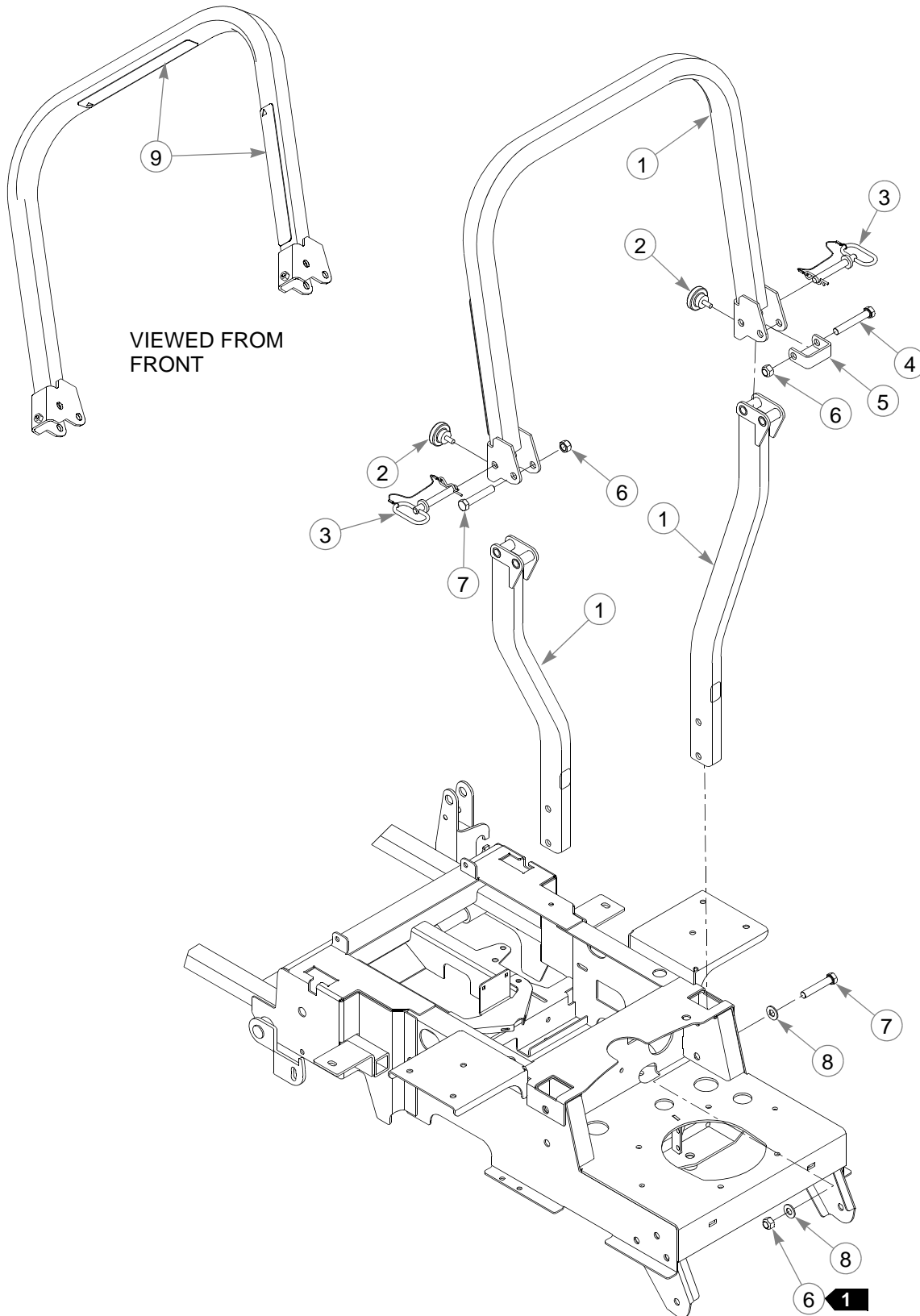

---

# **ROPS**

<b>INDEX NO.</b>	<b>PART NO.</b>	<b>QTY.</b>	<b>DESCRIPTION</b>
1	603696	1	ROPS KIT (WITH DECALS, SEATBELT & HARDWARE)
2	601470	2	HAND KNOB
3	601471	2	LYNCH PIN W/ LANYARD
4	077859	1	CS .500-13 X 3.25 HX G5
5	602647	1	ROPS STOP
6	023317	6	NT .500-13 UNT LK G8 ZN
7	721910	5	CS .500-13 X 2.75 HX G5 Z
8	767962	8	FW .531 X 1.063 X .090 SAE
9	601635	2	ROPS DECAL

---

## **NOTES:**

1. Torque to 55 ft-lbs.

