

# ***Hustler® Super Z Parts Manual***



**HUSTLER®**

.....

*Excel Industries, Inc.*

.....

*200 S. Ridge Road*

...

*Hesston, Kansas*

.

67062

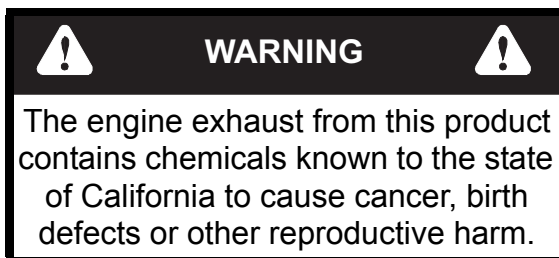

#### NOTICE OF REQUIREMENT OF SPARK ARRESTER MUFFLER

This equipment may create sparks that can start fires around dry vegetation. California Public Resources Code Section 4442.6 provides that it is unlawful to use or operate an internal combustion engine on any forest-covered, brush-covered, or grass-covered land unless the engine is equipped with a spark arrester maintained in effective working order. A spark arrester is a device constructed of nonflammable materials specifically for the purpose of removing and retaining carbon and other flammable particles over 0.0232 of an inch in size from the exhaust flow of an internal combustion engine that uses hydrocarbon fuels or which is qualified and rated by the United States Forest Service. Other states or federal areas may have similar laws. The Operator Should Contact Local Fire Agencies For Laws or Regulations Relating to Fire Prevention Requirements. THIS EQUIPMENT DOES NOT HAVE A SPARK ARRESTER AND YOU SHOULD CONTACT YOUR AUTHORIZED DEALER FOR THE PURCHASE OF A SPARK ARRESTER.

**Inspect spark arrester daily; replace every 500 hours or as needed.**

**The Engine Owner's Manual provides information regarding the U.S. Environmental Protection Agency (EPA) and the California Emission Control Regulation of emission systems, maintenance and warranty.**

**Keep Engine Owner's Manual with your unit. Should the Engine Owner's Manual become damaged or illegible, replace immediately. Replacements may be ordered per the information found in the Product Information section of the owner's manual.**

**Federal law and California State law prohibit the following acts or the causing thereof:**

- 1. The removal or rendering inoperative by any person other than for purposes of maintenance, repair, replacement, of any device or element of design incorporated into any equipment for the purposes of emissions control prior to or after its sales or delivery to the ultimate purchaser or while it is in use, or**
- 2. The use of the equipment after such device or element of design has been removed or rendered inoperative by any person.**

---

# Table of Contents

## General Information

Service Literature . . . . .	1-1
Options Available From Your Dealer. . . . .	1-1
Using This Manual . . . . .	1-1
Hardware Description Codes & Abbreviations . . . . .	1-2
Standard Torques . . . . .	1-2

## Section 2

Frame, Side Discharge . . . . .	2-2
Frame, Rear Discharge. . . . .	2-4
Footrest. . . . .	2-6

## Section 3

Hydraulic Components & Fittings . . . . .	3-2
Hydraulic Component Mounting . . . . .	3-4
Hydraulic Line Connections . . . . .	3-6
Hydraulic Motor Service Parts. . . . .	3-8
Hood . . . . .	3-10
Pump Drive . . . . .	3-12
Steering. . . . .	3-14
Brake. . . . .	3-18

## Section 4

Wheel & Tire, Semi-Pneumatic Caster Wheel . . . . .	4-2
Wheel & Tire, Pneumatic Caster Wheel . . . . .	4-4
Front Wheel Breakdown—Semi-Pneumatic Tire . . . . .	4-6
Front Wheel Breakdown—Pneumatic Tire . . . . .	4-7
Drive Wheel Breakdown . . . . .	4-8

## Section 5

Engine, Kawasaki FX850V—S/N 12031753 & Higher . . . . .	5-2
Engine, Kawasaki FX850V—S/N Prior to 12031753 . . . . .	5-6
Engine Service Parts, Kawasaki FX850V . . . . .	5-8
Engine, Kawasaki FX1000V—S/N 12031753 & Higher . . . . .	5-10
Engine, Kawasaki FX1000V—S/N Prior to 12031753 . . . . .	5-14
Engine Service Parts, Kawasaki FX1000V . . . . .	5-16
Fuel System (w/ Carbon Canister)—S/N 12071770 & Higher . . . . .	5-18
Vapor System (w/ Carbon Canister)—S/N 12071770 & Higher . . . . .	5-20
Fuel System (w/ Carbon Canister)—S/N Prior to 12071770 . . . . .	5-22
Vapor System (w/ Carbon Canister)—S/N Prior to 12071770 . . . . .	5-24
Fuel System—S/N 12071770 & Higher . . . . .	5-26
Fuel System (w/o Carbon Canister)—S/N Prior to 12071770 . . . . .	5-28
Fuel Tank Service Parts—S/N 12071770 & Higher . . . . .	5-30
Fuel Tank Service Parts—S/N Prior to 12071770 . . . . .	5-31
Engine Guard . . . . .	5-32

## Section 6

Battery—S/N 12031753 & Higher . . . . .	6-2
Battery—S/N Prior to 12031753 . . . . .	6-4

---

Instrument Panel–S/N 12071770 & Higher . . . . .	6-6
Instrument Panel–S/N Prior to 12071770. . . . .	6-8

**Section 7**

60" Side Discharge Service Deck. . . . .	7-2
60" Side Discharge Deck Pulleys & Spindles. . . . .	7-4
60" Side Discharge Deck . . . . .	7-6
66" Side Discharge Service Deck. . . . .	7-8
66" Side Discharge Deck Pulleys & Spindles. . . . .	7-10
66" Side Discharge Deck . . . . .	7-12
72" Side Discharge Service Deck. . . . .	7-14
72" Side Discharge Deck Pulleys & Spindles. . . . .	7-16
72" Side Discharge Deck . . . . .	7-18
Side Discharge Deck Lift . . . . .	7-20
Side Discharge Deck Mounting Hardware . . . . .	7-22
60" Rear Discharge Service Deck . . . . .	7-24
60" Rear Discharge Deck Pulleys & Spindles . . . . .	7-26
60" Rear Discharge Dust Shield. . . . .	7-30
60" Rear Discharge Deck . . . . .	7-32
72" Rear Discharge Service Deck . . . . .	7-36
72" Rear Discharge Deck Pulleys & Spindles . . . . .	7-38
72" Rear Discharge Dust Shield. . . . .	7-42
72" Rear Discharge Deck . . . . .	7-44
Rear Discharge Deck Lift . . . . .	7-48
Rear Discharge Deck Mounting Hardware . . . . .	7-50

**Section 8**

Seat, Super Deluxe . . . . .	8-2
Seat Service Parts, Super Deluxe . . . . .	8-4
Seat, Suspension . . . . .	8-6
Seat Service Parts, Suspension. . . . .	8-8
ROPS . . . . .	8-10

---

# General Information

This Manual covers Hustler® Super Z models: **929927, 929935, 929943, 929950, 930024, 930065, 930875, 931048, 931170US, 931188US & 931725.**

---

## Service Literature

PART NO.	DESCRIPTION
603029	OPERATOR MANUAL
113957	SERVICE MANUAL
114037	WARRANTY STATEMENT
113855	CALIFORNIA WARRANTY STATEMENT

---

## Options Available From Your Dealer

PART NO.	DESCRIPTION
603167	FLEX FORK KIT
114324	HITCH KIT
110153	LIGHT KIT
353961	STEERING LEVER EXTENSION KIT
113932	HYDRAULIC DECK KIT
113899	STRIPE KIT (60")
932467	3-BAG CATCHER
113903	3-BAG CATCHER ADAPTER KIT (60")
113904	3-BAG CATCHER ADAPTER KIT (66")
113905	3-BAG CATCHER ADAPTER KIT (72")
113722	MULCH KIT W/BLADES (60")
113723	MULCH KIT W/BLADES (66")
113724	MULCH KIT W/BLADES (72")
113911	DUAL REAR ANTI-SCALP KIT (60" & 66")
113937	DUAL REAR ANTI-SCALP KIT (72")
113910	SINGLE REAR ANTI-SCALP KIT
113679	SAND KIT (60")
113908	SAND KIT (66")
113909	SAND KIT (72")

*Note: When ordering parts, you must use the part number as shown for each part, not the index number. Always give the model and serial number to your parts and service representative.*

*Note: Items sold in bulk such as seals and hoses are sold by the foot.*

---

## Using This Manual

*This manual is part of a service package for the Hustler® mowers. Use of this manual in conjunction with other Hustler® mower and component manuals will provide the information necessary to service and maintain Hustler® mowers.*

*This Parts Manual provides a complete parts listing for the unit. Use this manual when ordering parts. Illustrations used were current at the time of printing, but subsequent production changes may cause your machine to vary slightly in detail. Excel Industries, Inc. reserves the right to redesign and change the machine as deemed necessary, without notification. If a change has been made to your machine which is not reflected in this parts manual, see your Hustler® dealer for current information and parts.*

*The Service Manual is a service guide for use by Service Technicians. It provides the necessary information needed to perform normal maintenance requirements on these units.*

*The Operator's Manual provides fundamental operational information and operational safety that is needed when operating the mower.*

*The component manuals are furnished by the various manufacturers to be used for the troubleshooting and servicing of their products.*

---

---

## **Hardware Description Codes & Abbreviations**

The following codes are used throughout this parts manual. Refer to this list when ordering parts.

<b>ABBREVIATION</b>	<b>DESCRIPTION</b>	<b>ABBREVIATION</b>	<b>DESCRIPTION</b>
CB	CARRIAGE BOLT	MB	MACHINE BUSHING
CE	CLEVIS PIN	MS	MACHINE SCREW
CN	CLIP NUT	NT	NUT
CP	COTTER PIN	SC	SELF TAPPING CAP SCREW
CS	CAP SCREW	SH	SOCKET HEAD
CW	CUP WASHER	SB	SHOULDER BOLT
FDRW	FENDER WASHER	SS	SET SCREW
FW	FLAT WASHER	OD	OUTSIDE DIAMETER
HX	HEX HEAD	ID	INSIDE DIAMETER
LW	LOCK WASHER		

---

## **Standard Torques**

The following chart lists the standard torque values for the threaded fasteners found in this manual. Torque all cap screws, nuts and set screws to these values unless a different torque is shown in the Notes section next to the fastener.

<b>SIZE</b>	<b>FT-LBS</b>	<b>N-M</b>	<b>SIZE</b>	<b>FT-LBS</b>	<b>N-M</b>
.250	8.2	11.1	M3	1	1.3
.312	17	23	M4	2.2	3
.375	30	40	M5	4.5	6.1
.438	48	65	M6	7.7	10.4
.500	73	99	M8	18.5	25
.562	105	143	M10	37	50
.625	145	200	M12	64	87
.750	260	350	M14	80	108.5
.875	420	565	M16	160	215
1.00	625	850	M20	320	435
			M24	555	750

---

## Section 2

Frame, Side Discharge .....	2-2
Frame, Rear Discharge .....	2-4
Footrest .....	2-6

# Frame, Side Discharge

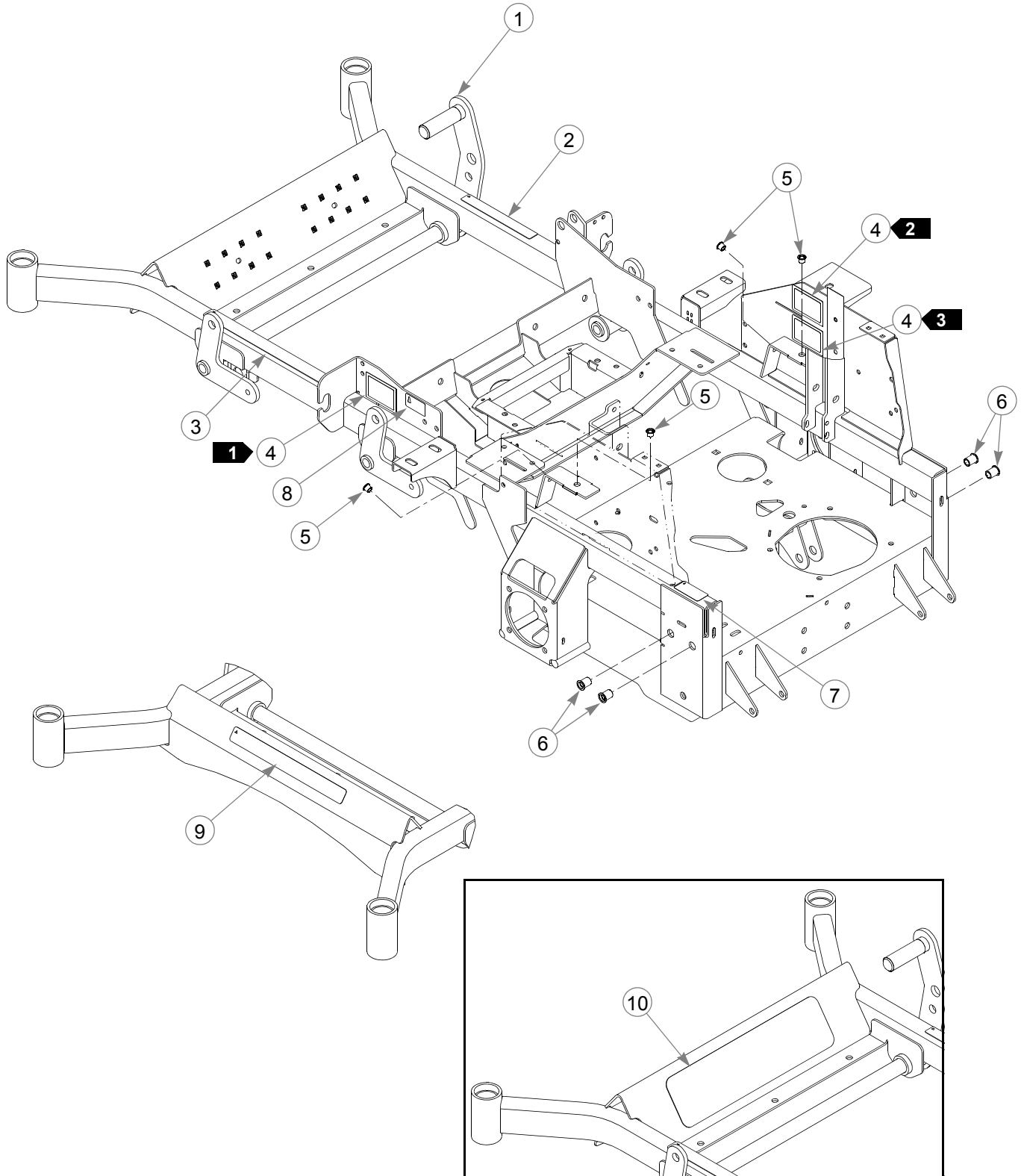



---

## **Frame, Side Discharge**

INDEX NO.	PART NO.	QTY.	DESCRIPTION
1	550820	1	60" MOWER FRAME (WITH DECALS & RIVET NUTS)
	550821	1	66" MOWER FRAME (WITH DECALS & RIVET NUTS)
	550822	1	72" MOWER FRAME (WITH DECALS & RIVET NUTS)
2	781427	1	DECK HEIGHT INDICATOR DECAL
3	601993	1	SAFE OPERATION DECAL
4	N/A	3	SERIAL NO. / SPEC DECAL
5	808493	4	3/8-16 THREAD RIVET NUT
6	600961	4	1/2-13 THREAD RIVET NUT
7	602041	1	HOT DECAL
8	727172	1	MADE IN USA DECAL
9	602407	1	HUSTLER ID DECAL
10	602323	1	STEP TREAD

---

### **NOTES:**

1. Serial number plate. In the event the serial number tag becomes damaged or illegible, please contact your dealer to order a replacement.
2. EPA compliance plate.
3. Patent numbers plate.

# Frame, Rear Discharge

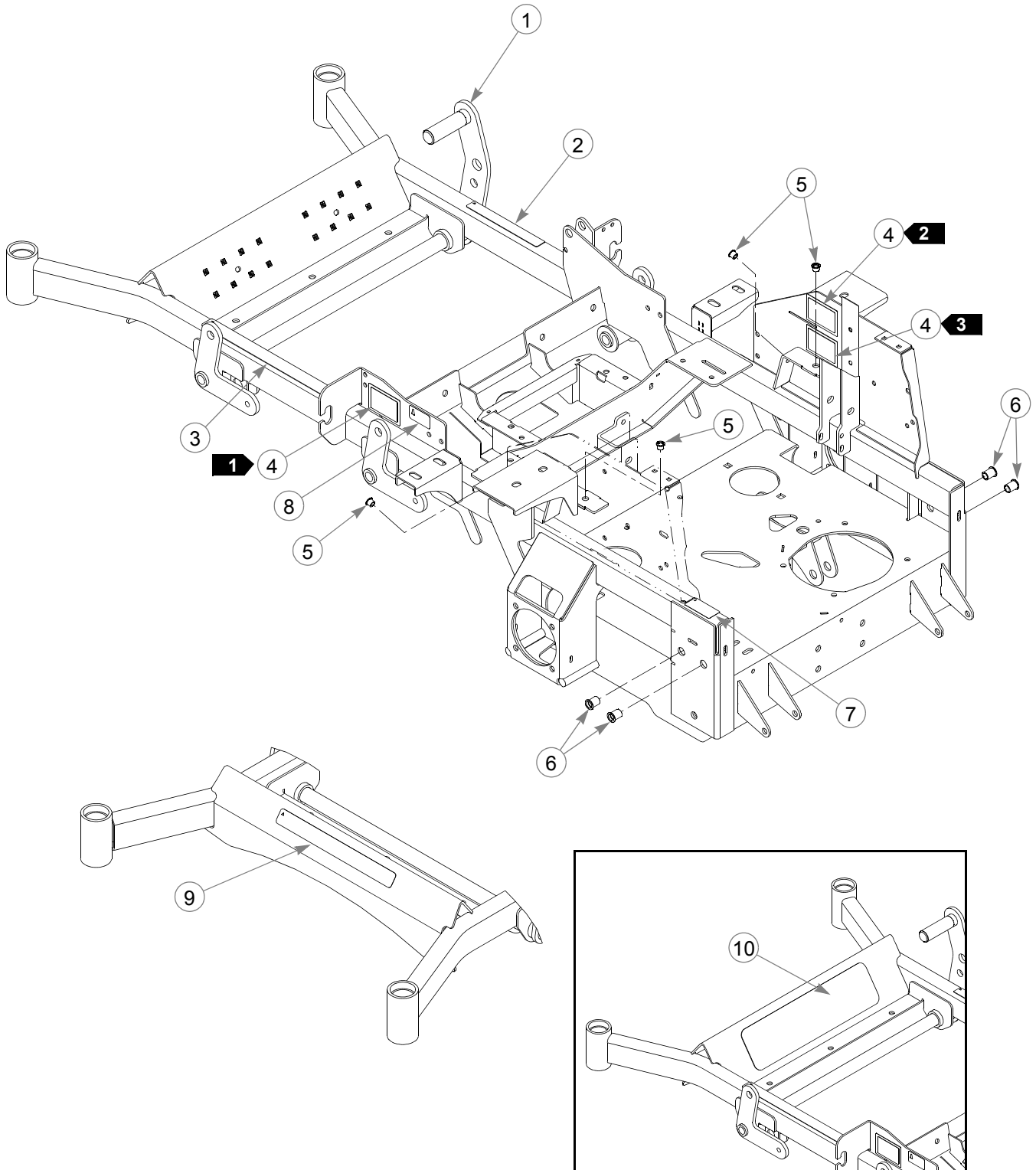

---

## **Frame, Rear Discharge**

INDEX NO.	PART NO.	QTY.	DESCRIPTION
1	550972	1	60" MOWER FRAME (WITH DECALS & RIVET NUTS)
	550973	1	72" MOWER FRAME (WITH DECALS & RIVET NUTS)
2	781427	1	DECK HEIGHT INDICATOR DECAL
3	601993	1	SAFE OPERATION DECAL
4	N/A	3	SERIAL NO. / SPEC DECAL
5	808493	4	3/8-16 THREAD RIVET NUT
6	600961	4	1/2-13 THREAD RIVET NUT
7	602041	1	HOT DECAL
8	727172	1	MADE IN USA DECAL
9	602407	1	HUSTLER ID DECAL
10	602323	1	STEP TREAD

---

### **NOTES:**

1. Serial number plate. In the event the serial number tag becomes damaged or illegible, please contact your dealer to order a replacement.
2. EPA compliance plate.
3. Patent numbers plate.

# Footrest

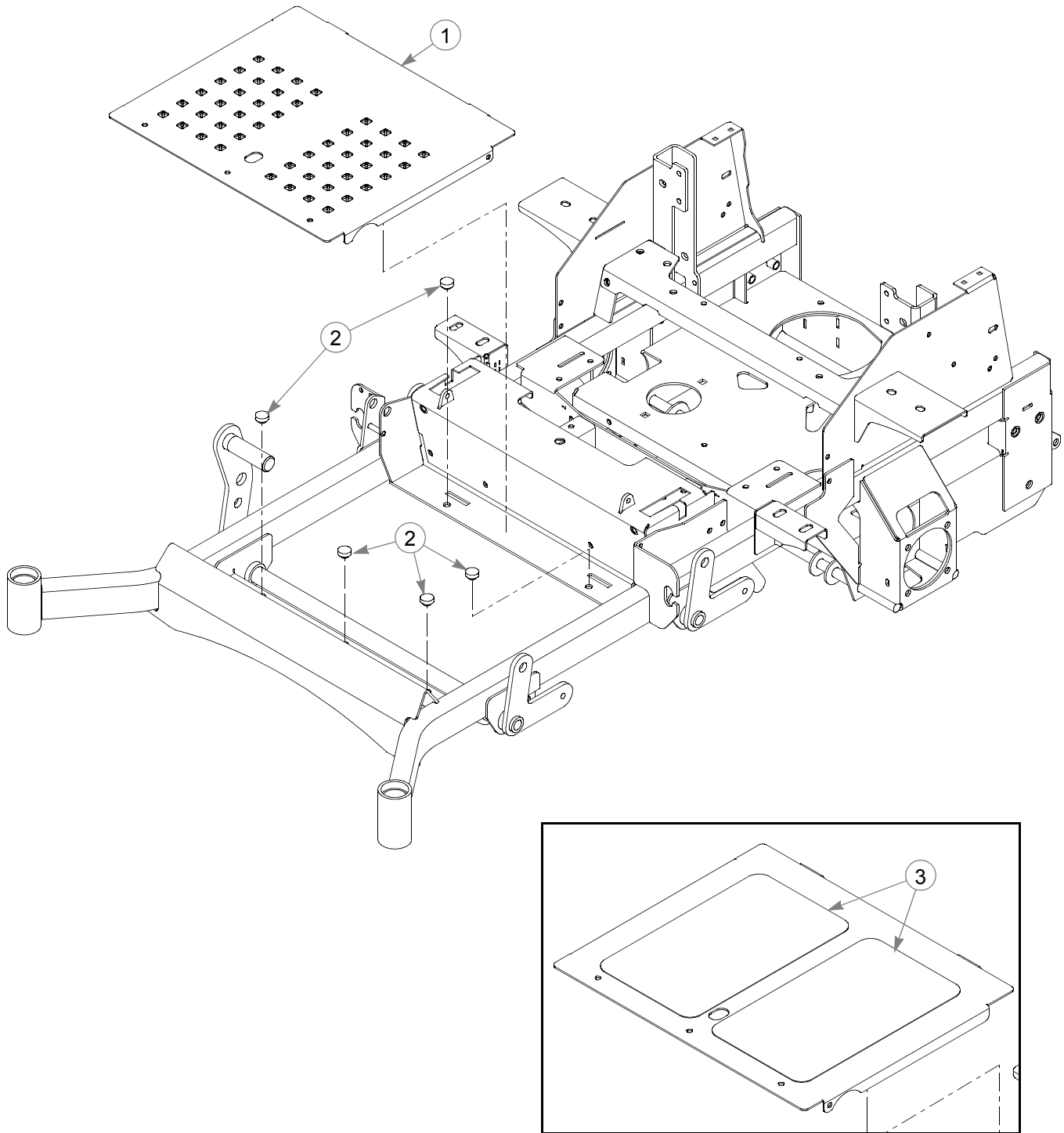

---

# **Footrest**

INDEX NO.	PART NO.	QTY.	DESCRIPTION
1	117323	1	FLOOR PLATE
2	781880	5	BUMPER
3	785493	2	LOWER STEP TREAD

---

## **NOTES:**



---

## Section 3

Hydraulic Components & Fittings . . . . .	3-2
Hydraulic Component Mounting . . . . .	3-4
Hydraulic Line Connections . . . . .	3-6
Hydraulic Motor Service Parts . . . . .	3-8
Hood . . . . .	3-10
Pump Drive . . . . .	3-12
Steering . . . . .	3-14
Brake . . . . .	3-18

# Hydraulic Components & Fittings

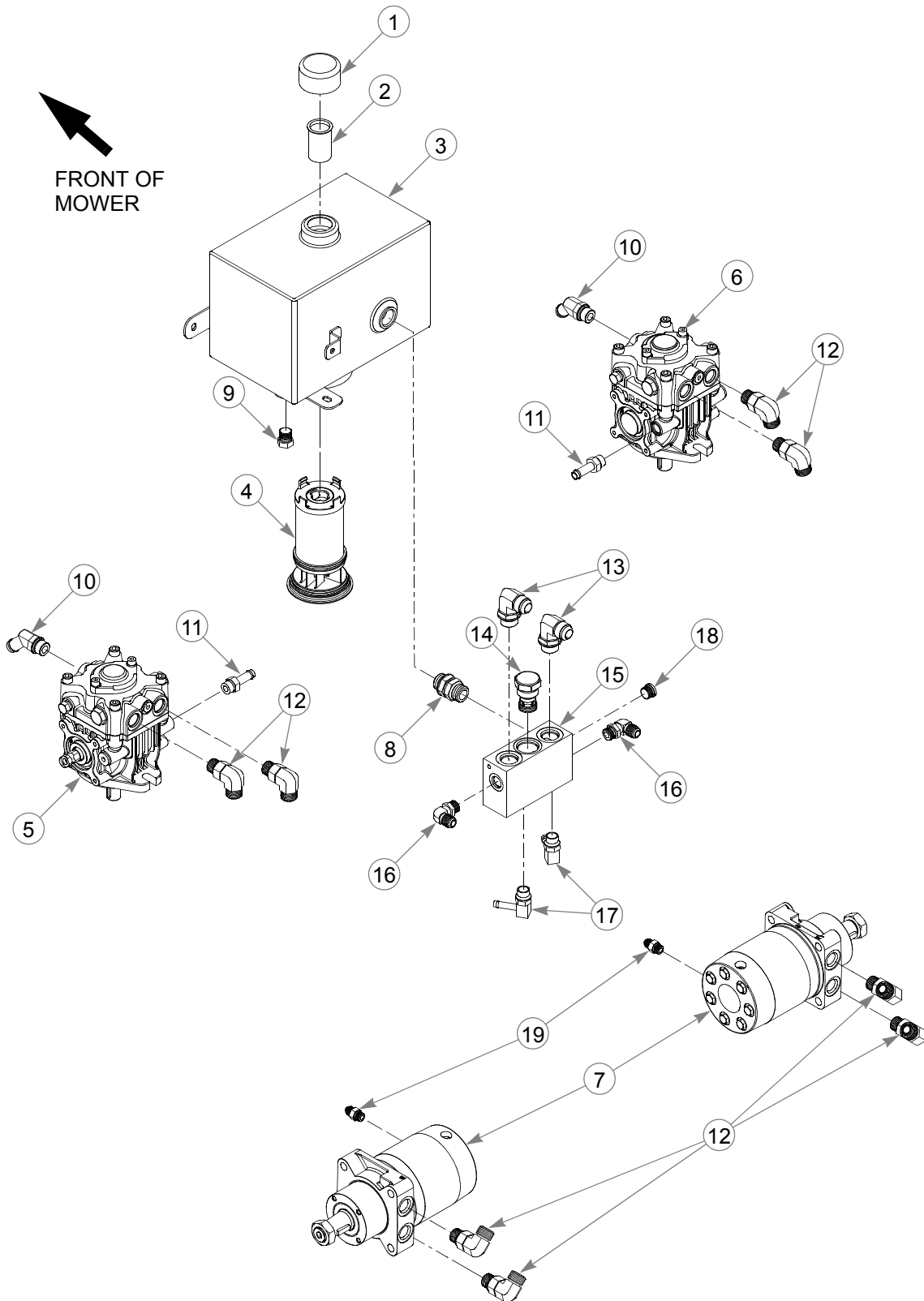



---

## **Hydraulic Components & Fittings**

INDEX NO.	PART NO.	QTY.	DESCRIPTION
1	032763	1	BREATHER CAP
2	032771	1	STRAINER
3	602767	1	HYDRAULIC RESERVOIR
4	602768X	1	FILTER, HYDRAULIC SUCTION
5	602556	1	LS PUMP
6	602964	1	RS PUMP
	603362	1	SEAL KIT, PUMP (NOT SHOWN)
7	602714	2	MOTOR
8	603039	1	FTG, -12MORB/-12MORB STR
9	781658	1	FTG, -8 MORB HEX PLUG
10	774968	2	FTG, -10MORB/-12BT 45°
11	601523	2	FTG, -8MORB/-8BT STR
12	602443	8	FTG, -10MORB/-10MORFS 90°
13	603189	2	FTG, -12MORB/-12MJIC 90°
14	603053	1	CHECK VALVE
15	603000	1	CASE DRAIN MANIFOLD
16	771311	2	FTG, -8MORB/-8MJIC, 90°
17	603190	2	FTG, -8MORB/-6BT 90°
18	603123	1	FTG, -8MORB HEX PLUG
19	779132	2	FTG, -6MORB/-6MJIC STR

---

### **NOTES:**

# Hydraulic Component Mounting

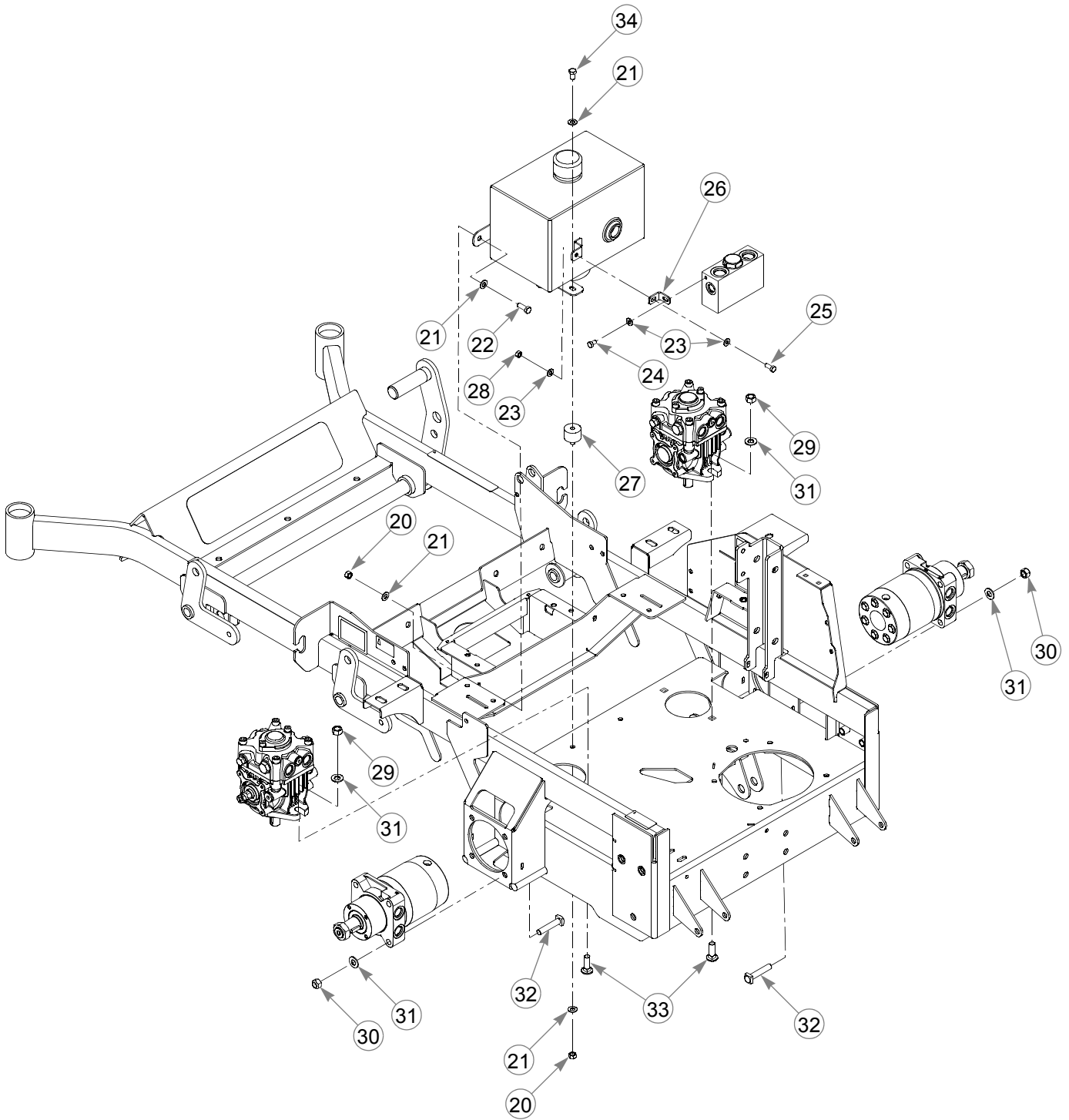

---

## **Hydraulic Component Mounting**

INDEX NO.	PART NO.	QTY.	DESCRIPTION
20	054502	5	NT .375-16 HX G5 ZNY
21	767954	10	FW .406 X .812 X .060 SAE
22	036244	4	CS .375-16 X 1.00 HX G5
23	768523	3	FW .343 X .687 X .051/.080H
24	068346	1	CS .312-18 X .50 HX G8
25	034280	1	CS .312-18 X .75 HX G5
26	113623	1	SUPPORT BRACKET
27	601571	1	VIBRATION MOUNT
28	034272	1	NT .312-18 HX G5 ZNYC
29	008193	4	NT .500-13 HX G5 ZNYC
30	023317	8	NT .500-13 UNT LK G8 ZN
31	767962	12	FW .531 X 1.063 X .090 SAE
32	602256	8	CS .500-13 X 2.50 SQ G5
33	028274	4	CB .500-13 X 1.50 FULL
34	056069	1	CS .375-16 X .625 HX G5

---

### **NOTES:**

# Hydraulic Line Connections

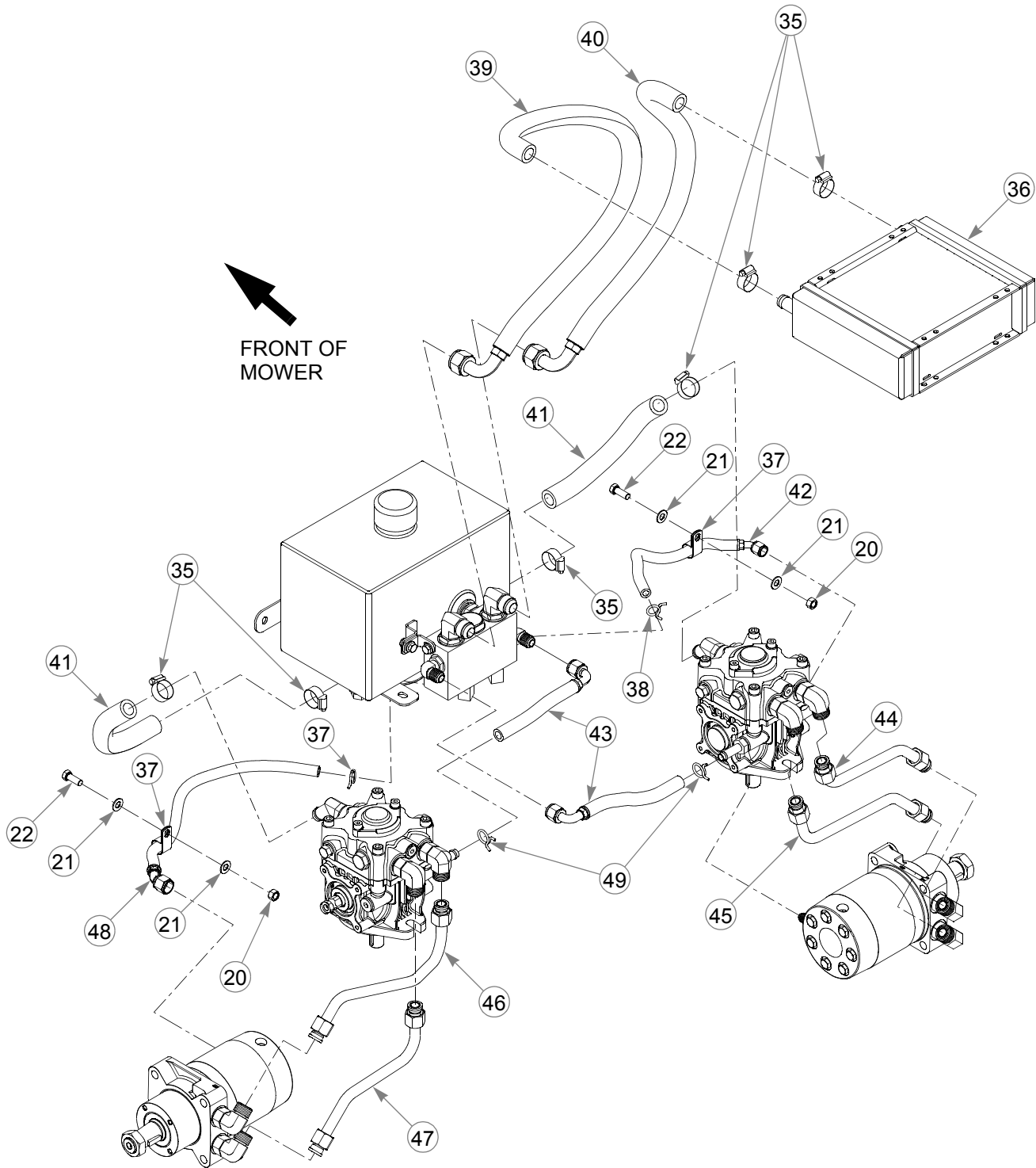

---

## **Hydraulic Line Connections**

INDEX NO.	PART NO.	QTY.	DESCRIPTION
35	700484	6	HOSE CLAMP
36	602709	1	HYDRAULIC OIL COOLER
37	043570	2	LOOP CLAMP
38	601617	2	SPRING CLAMP
39	603046	1	HOSE, TO COOLER
40	603047	1	HOSE, FROM COOLER
41	603045	2	PUMP SUCTION HOSE
42	603044	1	RS CASE DRAIN HOSE
43	603042	2	HOSE, PUMP CASE DRAIN
44	602876	1	TUBE, RP-TM RH LOOP
45	602875	1	TUBE, LP-BM RH LOOP
46	602874	1	TUBE, RP-TM LH LOOP
47	602873	1	TUBE, LP-BM LH LOOP
48	603043	1	LS CASE DRAIN HOSE
49	601001	2	SPRING CLAMP

---

### **NOTES:**

---

## **Hydraulic Motor Service Parts**

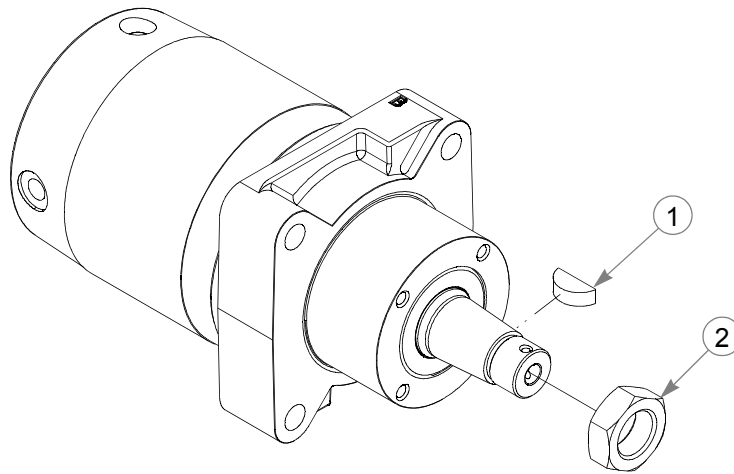

---

INDEX NO.	PART NO.	QTY.	DESCRIPTION
1	064337	1	WOODRUFF KEY
2	065516	1	CASTLE NUT
3	748806	1	SEAL KIT (NOT SHOWN)

---

### **NOTES:**

---

**This page intentionally left blank.**

# Hood

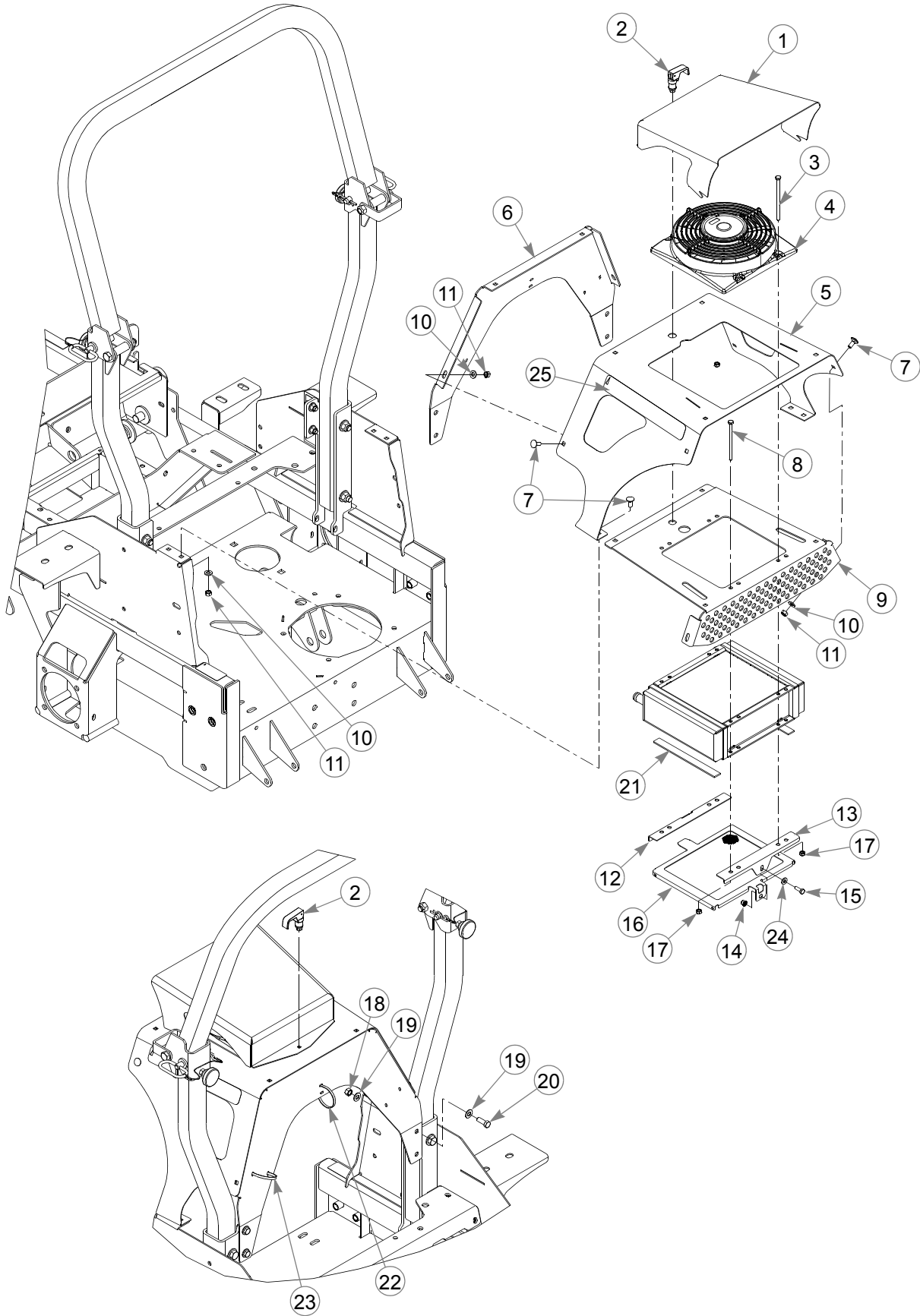



---

# Hood

INDEX NO.	PART NO.	QTY.	DESCRIPTION
1	114038	1	AIR SCOOP
2	791384	1	LATCH
3	603229	4	CS .250-20 X 4.50 HX G5
4	603066	1	FAN 9"
5	550860	1	OIL COOLER COVER (WITH DECALS)
6	114040	1	COOLER MOUNT FIREWALL
7	016253	12	CB .312-18 X .75 FUL ZN
8	603228	2	CS .250-20 X 4.00 HX G5
9	114039	1	UPPER COOLER MOUNT
10	768523	12	FW .343 X .687 X .051/.080H
11	034272	12	NT .312-18 HX G5 ZNYC
12	114141	1	FRONT SCREEN MOUNT BRACKET
13	114142	1	REAR SCREEN MOUNT BRACKET
14	808477	1	1/4-20 THREAD RIVET NUT
15	055939	1	CS .250-20 X .75 HX G5
16	114165	1	SCREEN
17	068551	6	NT .250-20 HX ZY NL
18	054502	4	NT .375-16 HX G5 ZNY
19	767954	8	FW .406 X .812 X .060 SAE
20	036244	4	CS .375-16 X 1.00 HX G5
21	033035	7.75"	WEATHERSTRIP
22	000331	1	WIRE TIE
23	000430	2	WIRE TIE
24	768515	1	FW .281 X .625 X .051/.080H
25	603290	2	HYPERDRIVE DECAL

---

## NOTES:

# Pump Drive

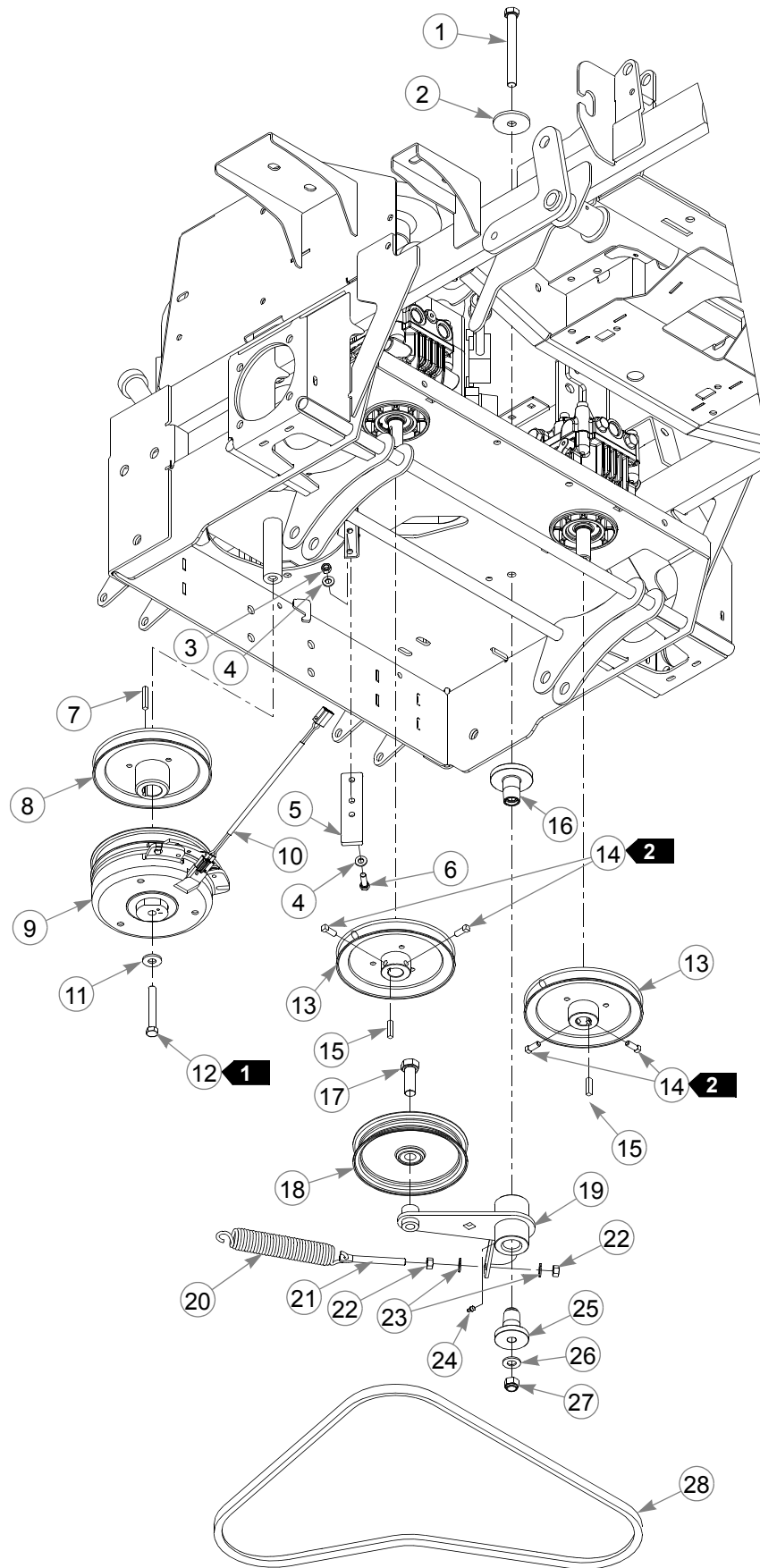

---

## **Pump Drive**

INDEX NO.	PART NO.	QTY.	DESCRIPTION
1	051151	1	CS .500-13 X 5.00 HX G5
2	344267	1	FW .510 X 2.15 X .187 SPL
3	034272	2	NT .312-18 HX G5 ZNYC
4	768523	4	FW .343 X .687 X .051/.080H
5	113347	1	CLUTCH ANCHOR
6	036236	2	CS .312-18 X 1.00 HX G5
7	212076	1	KEY 1/4 SQ X 1.50 LG
8	602755	1	PULLEY 7.0 OD X 1.125 SHFT
9	603336K	1	CLUTCH KIT
10	791251	1	CLUTCH HARNESS PIGTAIL
11	602680	1	FW .453 X 1.12 X .119 HRD
12	785048	1	CS .437-20 X 3.00 HX G5 P85
13	602754	2	PULLEY 7.35 OP X 0.875 SHFT
14	083196	4	SS .312-18 X .75 SQ-HD
15	210146	2	KEY 1/4 SQ X 1.12 LONG
16	602880	1	IDLER PIVOT BUSHING
17	025007	1	CS .625-11 X 1.75 HX G5
18	781385	1	IDLER PULLEY NHI 6.0"
19	113403	1	TENSIONER
20	601016	1	IDLER SPRING
21	601486	1	EB, .375-16 X 3.00 FULL THD
22	054502	2	NT .375-16 HX G5 ZNY
23	767954	2	FW .406 X .812 X .060 SAE
24	015495	1	GREASE FITTING STRAIGHT
25	602879	1	IDLER PIVOT BUSHING
26	767962	1	FW .531 X 1.063 X .090 SAE
27	781567	1	NT .500-13 NL G5
28	602762	1	BELT, B COG 69.36 EL

---

### **NOTES:**

1. Torque to 45–48 ft-lbs. If the fastener is loosened or removed, do not re-use it. Replace it with a new fastener. Use only hand tools to install this fastener.
2. Torque to 12–15 ft-lbs.

# Steering

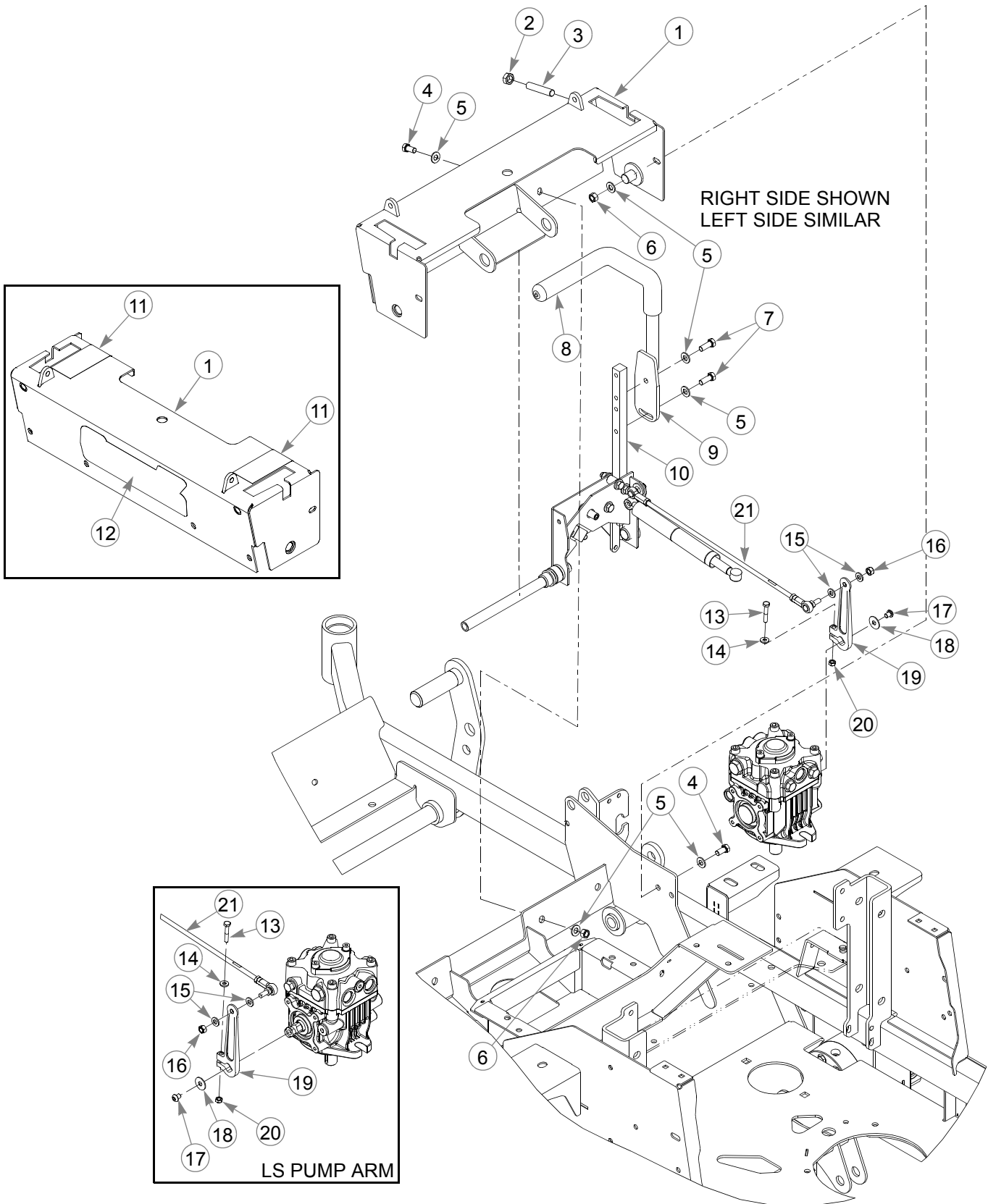

---

# **Steering**

INDEX NO.	PART NO.	QTY.	DESCRIPTION
1	550818	1	STEERING COVER (WITH DECALS)
2	053199	2	NT .500-13 HX JAM ZNYC
3	603055	2	SS 1/2-13 X 2.50 SH ZNYC
4	055822	6	CS .375-16 X .75 HX G5
5	767954	28	FW .406 X .812 X .060 SAE
6	054502	6	NT .375-16 HX G5 ZNY
7	036244	4	CS .375-16 X 1.00 HX G5
8	781260	2	STEERING BAR GRIP
9	109839	2	HANDLE (WITH GRIP)
10	113575	2	STEERING ARM
11	722199	11"	WEAR TAPE
12	604557	1	SUPER Z HD DECAL
13	008581	2	CS .250-20 X 1.50 HX G5
14	768515	2	FW .281 X .625 X .051/.080 HD ZN/YL
15	768523	12	FW .343 X .687 X .051/.080H
16	023655	4	NT .312-24 HX NL ZN
17	603272	2	CS M8-1.25 X 10 G10.9 SHBH
18	079210	2	FW .344 X 1.00 X .06 ZNYC
19	602732	2	PUMP ARM
20	068551	2	NT .250-20 HX ZY NL
21	781286	2	PUMP ROD ADJUSTER

---

## **NOTES:**

# Steering

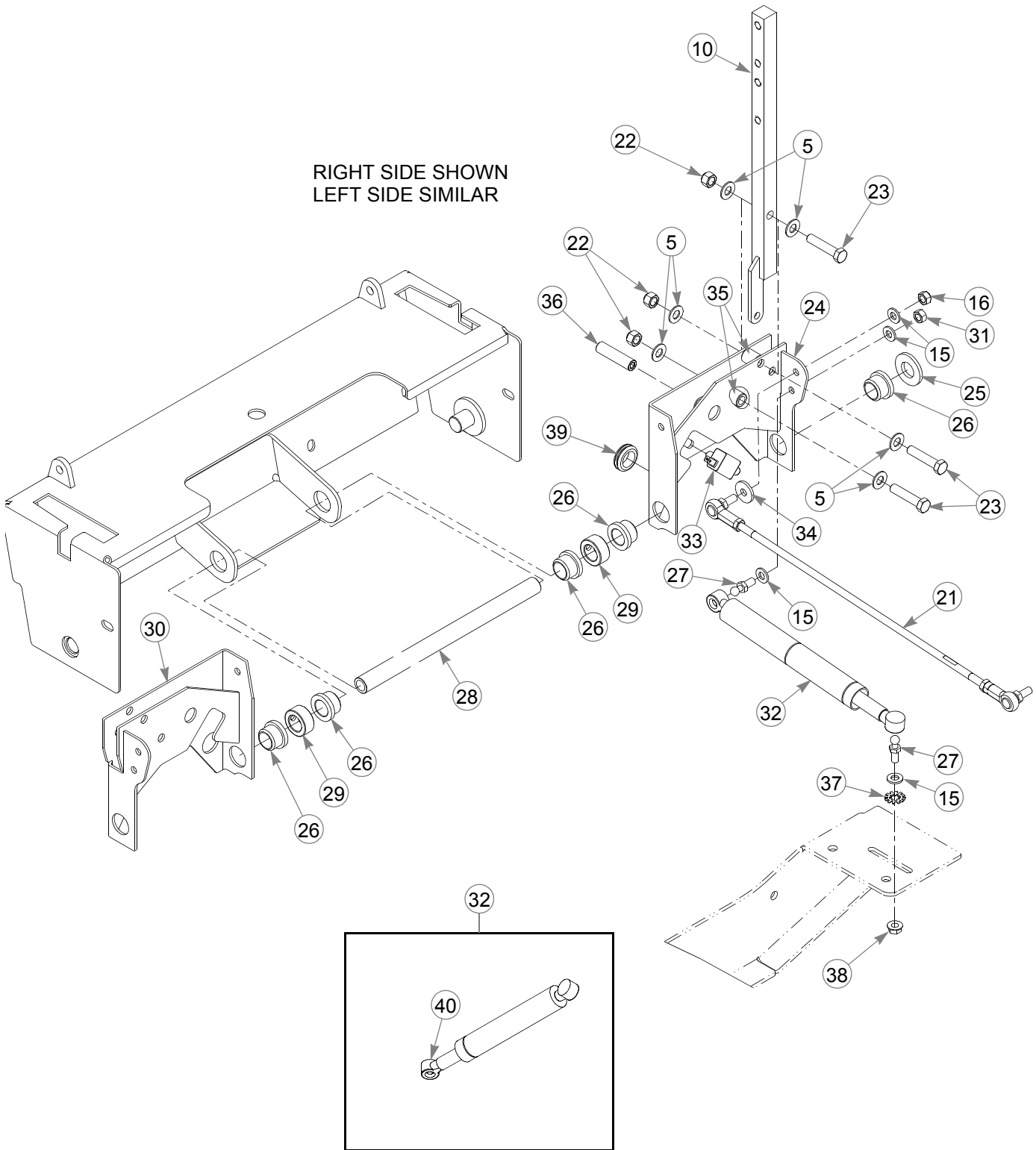

---

## **Steering**

INDEX NO.	PART NO.	QTY.	DESCRIPTION
22	086660	6	NT .375-16 HX ZY NL
23	705178	6	CS .375-16 X 1.75 HX G5
24	112898	1	RS STEERING BOX
25	603078	2	FW .750 X 1.50 X .156 ZN
26	781153	6	BUSHING
27	781922	4	BALL STUD
28	113007	1	STEER PIVOT TUBE
29	784439	2	LOCK COLLAR, 0.757 ID
30	112899	1	LS STEERING BOX
31	034272	2	NT .312-18 HX G5 ZNYC
32	603192	2	DAMPER
33	601087	2	SWITCH
34	712927	2	FW .344 X 1.00 X .12 HRD Z
35	348862	4	STEERLEVER BUSHING
36	797738	2	SS .500-13 X 2.00 SH ZY
37	029876	2	LW .312 INT-EXT TOOTH
38	016832	2	NT .312-18 HX FLK ZNYC
39	047456	2	GM .750 X .188 X 1.00 X .12
40	601426	1	CAP LOCK

---

### **NOTES:**

# Brake

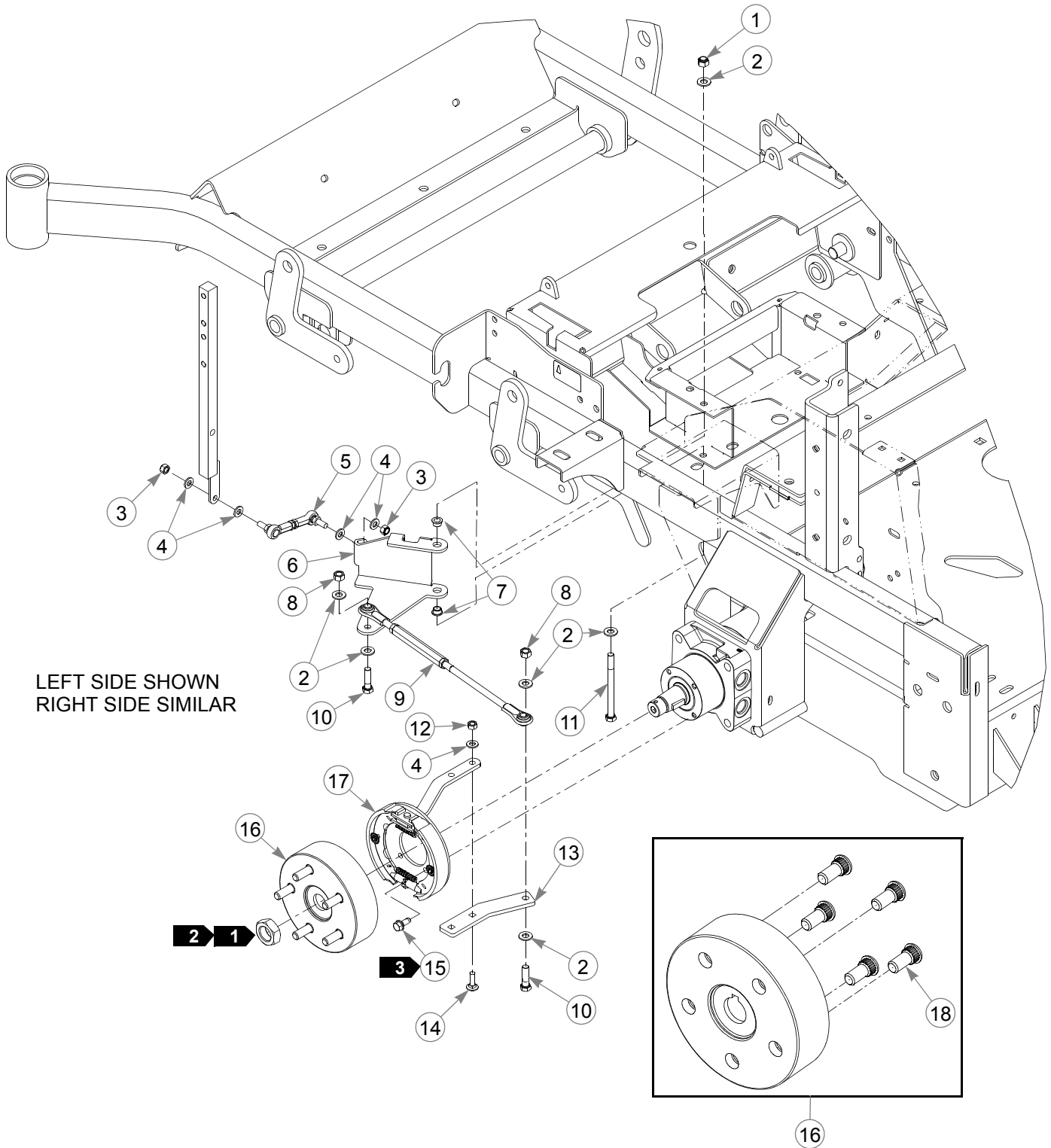



---

## **Brake**

INDEX NO.	PART NO.	QTY.	DESCRIPTION
1	086660	2	NT .375-16 HX ZY NL
2	767954	12	FW .406 X .812 X .060 SAE
3	023655	4	NT .312-24 HX NL ZN
4	768523	12	FW .343 X .687 X .051/.080H
5	781583	2	BRAKE ROD ASSEMBLY
6	112907	1	LS BRAKE BELLCRANK
	112906	1	RS BRAKE BELLCRANK (NOT SHOWN)
7	765339	4	BUSHING
8	054502	4	NT .375-16 HX G5 ZNY
9	350397	2	BRAKE LINK TURNBUCKLE
10	005116	4	CS .375-16 X 1.375 HX G5
11	052514	2	CS .375-16 X 4.50 HX G5
12	034272	4	NT .312-18 HX G5 ZNYC
13	111309	2	BRAKE ARM
14	037887	4	CB .312-18 X 1.00 FULL ZN
15	604461	8	CS .312-18 X .875 HX G8 FLK
16	602384	2	HUB ASSEMBLY (WITH STUDS)
17	602383	2	BRAKE ASSEMBLY
18	601085	5	STUD

---

### **NOTES:**

1. Included with the wheel motor.
2. Torque to 220–240 ft-lbs.
3. Torque to 27 ft-lbs.



---

## Section 4

Wheel & Tire, Semi-Pneumatic Caster Wheel . . . . .	4-2
Wheel & Tire, Pneumatic Caster Wheel . . . . .	4-4
Front Wheel Breakdown—Semi-Pneumatic Tire . . . . .	4-6
Front Wheel Breakdown—Pneumatic Tire . . . . .	4-7
Drive Wheel Breakdown . . . . .	4-8

# Wheel & Tire, Semi-Pneumatic Caster Wheel

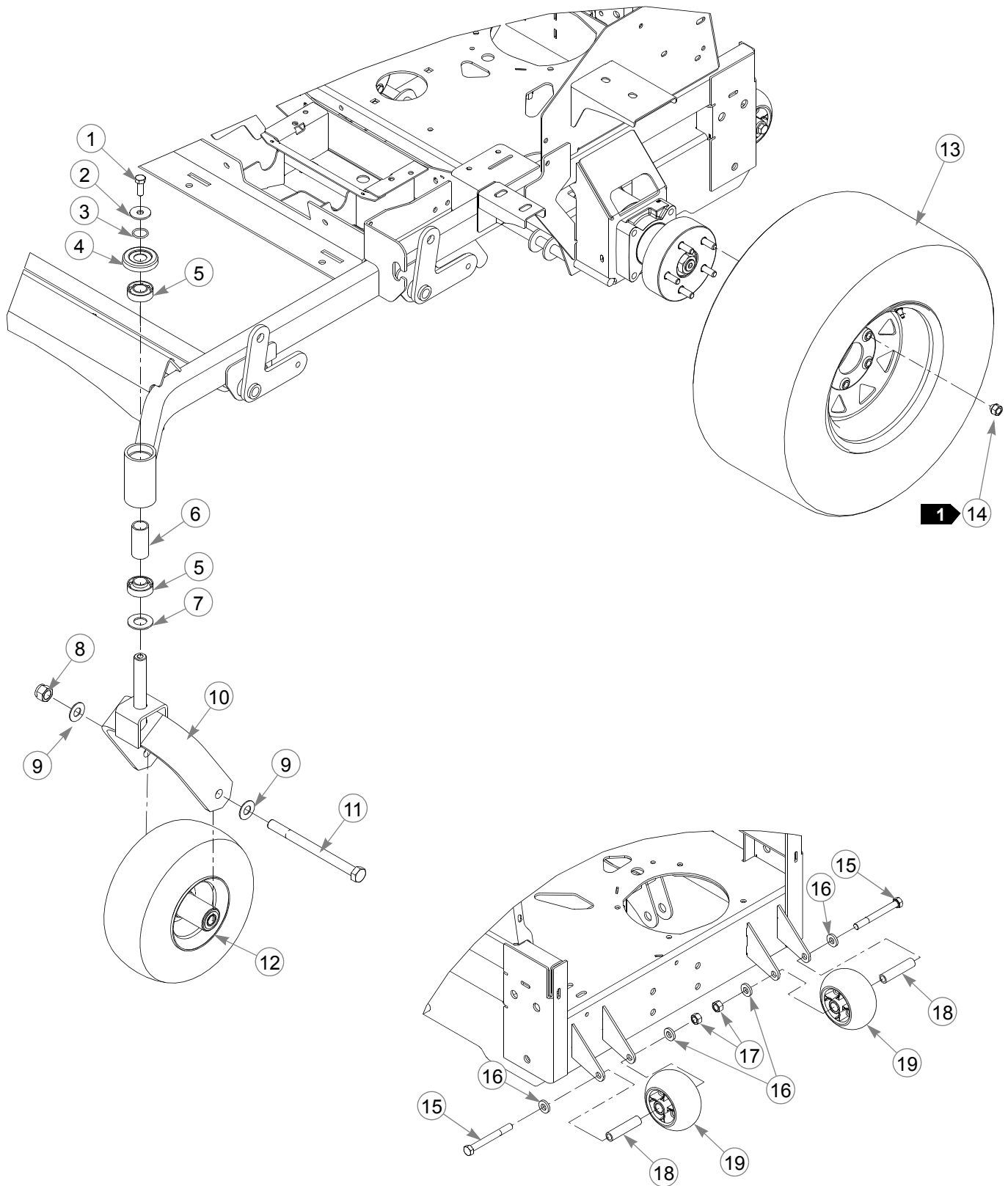

---

## **Wheel & Tire, Semi-Pneumatic Caster Wheel**

INDEX NO.	PART NO.	QTY.	DESCRIPTION
1	705954	2	CS .500-13 X 1.25 HX G5 ZN
2	798603	2	FW .515 X 1.65 X .125 HD ZY
3	601375	2	O-RING, SAE-14
4	603153	2	DUST CAP
5	784223	4	BEARING
6	387035	2	SPACER, 1.07 X 1.312 X 2.79
7	603164	2	DISC BEARING
8	061101	2	NT .750-10 HX ZY NL
9	025296	4	FW .760 X 1.625 X .08 ZNYC
10	113621	2	FORK
11	041475	2	CS .750-10 X 9.50 HX ZY
12	789537	2	TIRE/WHEEL ASSEMBLY 13 X 6.50-6
13	601238	2	TIRE/WHEEL ASSEMBLY 24 X 12 X 12 (60" MOWER)
	784058	2	TIRE/WHEEL ASSEMBLY 24 X 12 X 12 (72" MOWER)
14	061077	10	WHEEL NUT
15	068239	2	CS .500-13 X 4.50 HX G5
16	767962	4	FW .531 X 1.063 X .090 SAE
17	008193	2	NT .500-13 HX G5 ZNYC
18	602345	2	SPACER 3.22
19	602263	2	PLASTIC WHEEL

---

### **NOTES:**

1. Torque to 65–75 ft-lbs.

# Wheel & Tire, Pneumatic Caster Wheel

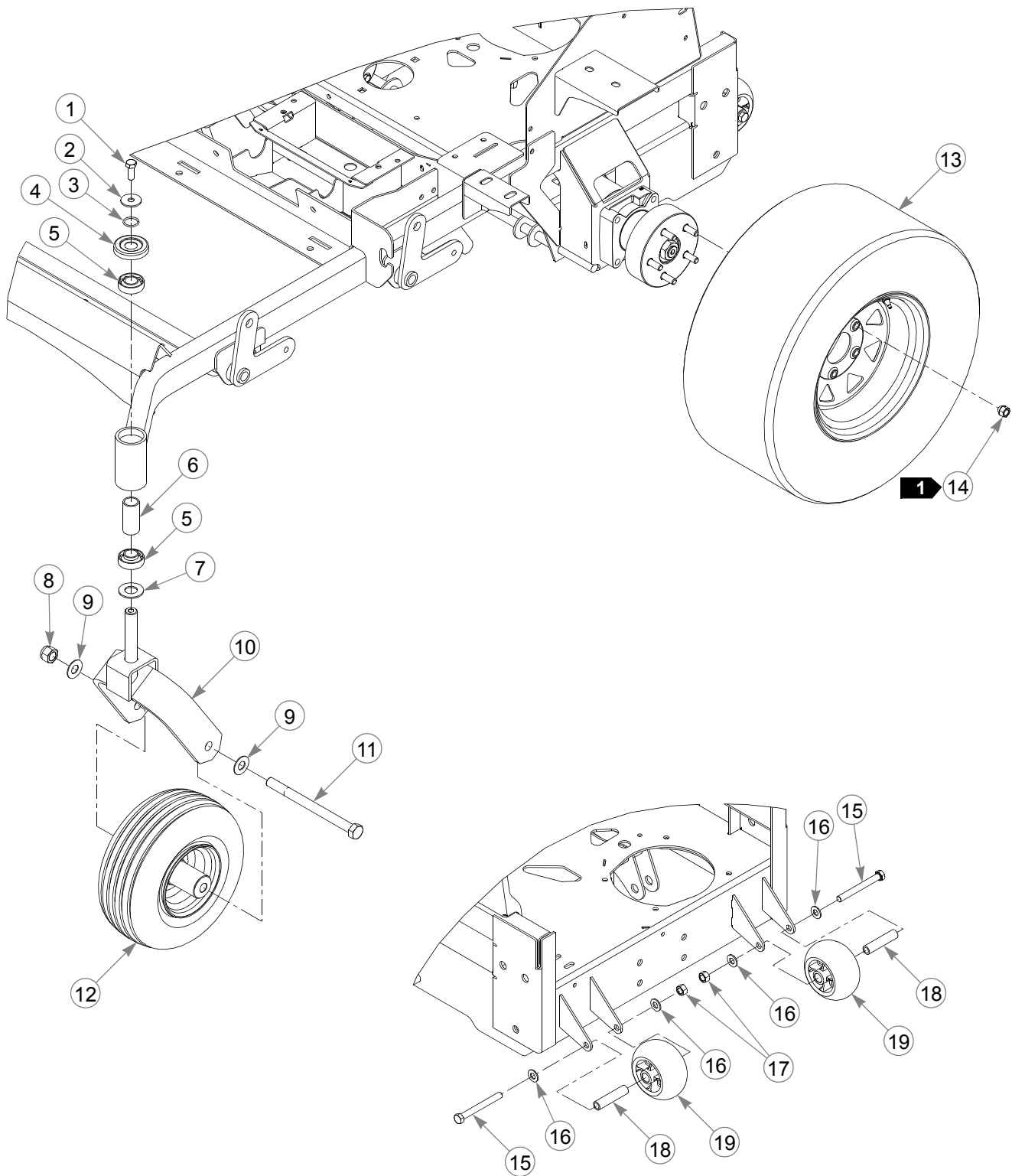

---

## **Wheel & Tire, Pneumatic Caster Wheel**

INDEX NO.	PART NO.	QTY.	DESCRIPTION
1	705954	2	CS .500-13 X 1.25 HX G5 ZN
2	798603	2	FW .515 X 1.65 X .125 HD ZY
3	601375	2	O-RING, SAE-14
4	603153	2	DUST CAP
5	784223	4	BEARING
6	387035	2	SPACER 1.07 X 1.312 X 2.79
7	603164	2	DISC BEARING
8	061101	2	NT .750-10 HX ZY NL
9	025296	4	FW .760 X 1.625 X .08 ZNYC
10	113621	2	FORK
11	041475	2	CS .750-10 X 9.50 HX ZY
12	747782	2	TIRE/WHEEL ASSEMBLY 13 X 6.50
13	601238	2	TIRE/WHEEL ASSEMBLY 24 X 12 X 12 (60" MOWER)
	784058	2	TIRE/WHEEL ASSEMBLY 24 X 12 X 12 (66"/72" MOWER)
14	061077	10	WHEEL NUT
15	068239	2	CS .500-13 X 4.50 HX G5
16	767962	4	FW .531 X 1.063 X .090 SAE
17	008193	2	NT .500-13 HX G5 ZNYC
18	602345	2	SPACER 3.22
19	602263	2	PLASTIC WHEEL

---

### **NOTES:**

1. Torque to 65–75 ft-lbs.

---

## **Front Wheel Breakdown—Semi-Pneumatic Tire**

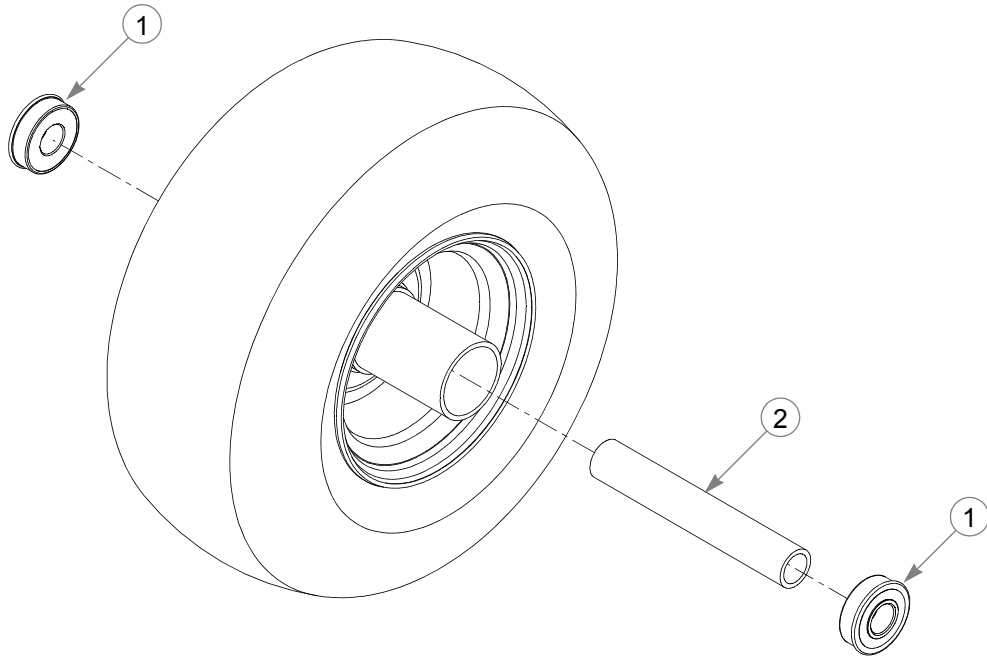

---

INDEX NO.	PART NO.	QTY.	DESCRIPTION
1	039677	2	WHEEL BEARING
2	782771	1	BEARING SPACER

---

### **NOTES:**



# Front Wheel Breakdown—Pneumatic Tire

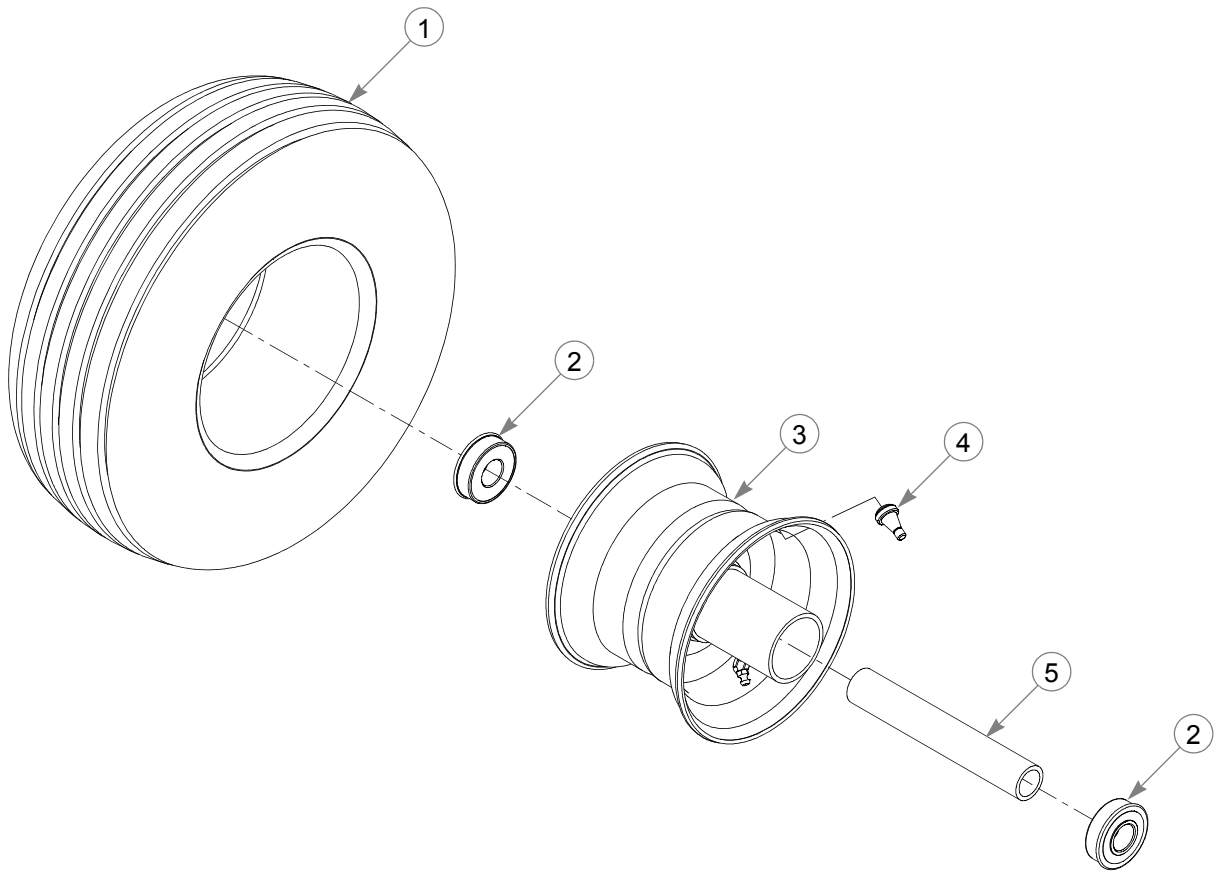

---

INDEX NO.	PART NO.	QTY.	DESCRIPTION
1	747741	1	TIRE 13 X 6.5
2	039677	2	WHEEL BEARING
3	747832	1	WHEEL 6 X 4.5
4	019521	1	VALVE STEM
5	782771	1	BEARING SPACER

---

## NOTES:

# Drive Wheel Breakdown

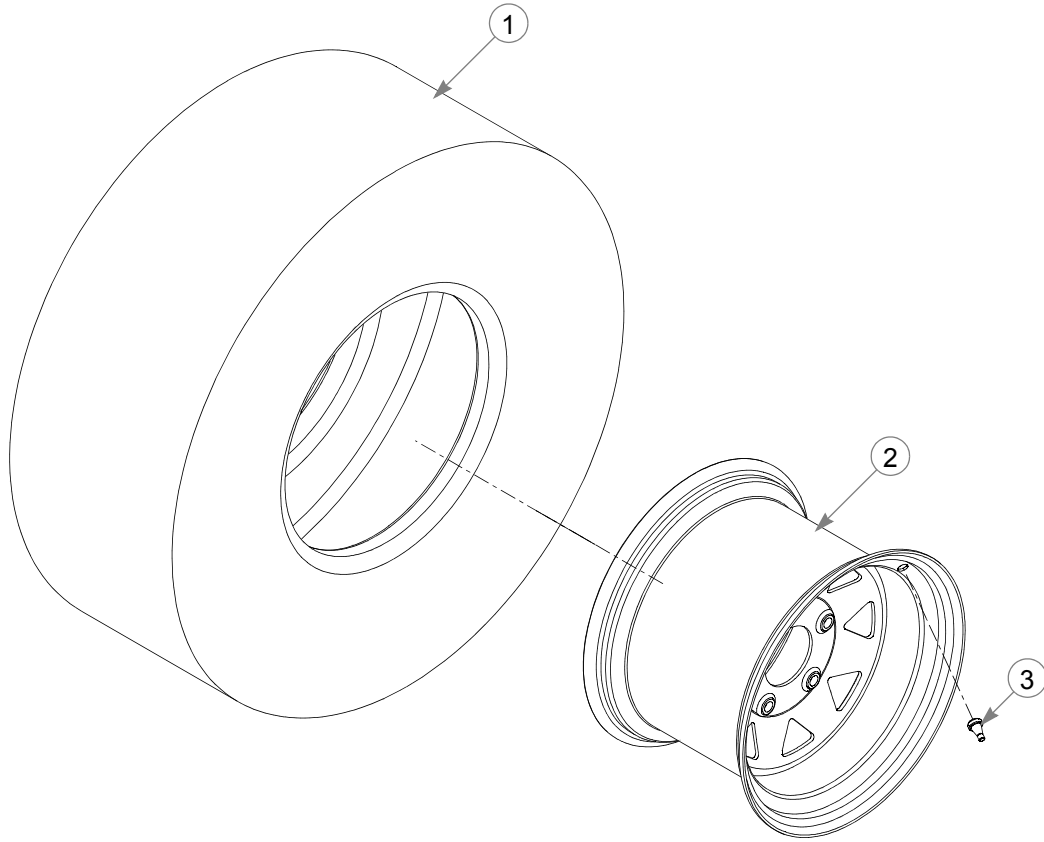

## 601238 TIRE/WHEEL ASSEMBLY (60" DECKS)

INDEX NO.	PART NO.	QTY.	DESCRIPTION
1	781245	1	TIRE, 24 X 12-12
2	796250	1	WHEEL, 12 X 7.00
3	019521	1	VALVE STEM

## 784058 TIRE/WHEEL ASSEMBLY (66" & 72" DECKS)

INDEX NO.	PART NO.	QTY	DESCRIPTION
1	781245	1	TIRE, 24 X 12-12
2	784066	1	WHEEL, 12 X 8.50
3	019521	1	VALVE STEM

### NOTES:

---

## Section 5

Engine, Kawasaki FX850V—S/N 12031753 & Higher . . . . .	5-2
Engine, Kawasaki FX850V—S/N Prior to 12031753. . . . .	5-6
Engine Service Parts, Kawasaki FX850V . . . . .	5-8
Engine, Kawasaki FX1000V—S/N 12031753 & Higher . . . . .	5-10
Engine, Kawasaki FX1000V—S/N Prior to 12031753. . . . .	5-14
Engine Service Parts, Kawasaki FX1000V . . . . .	5-16
Fuel System (w/ Carbon Canister)—S/N 12071770 & Higher. . . . .	5-18
Vapor System (w/ Carbon Canister)—S/N 12071770 & Higher . . . . .	5-20
Fuel System (w/ Carbon Canister)—S/N Prior to 12071770. . . . .	5-22
Vapor System (w/ Carbon Canister)—S/N Prior to 12071770 . . . . .	5-24
Fuel System—S/N 12071770 & Higher. . . . .	5-26
Fuel System (w/o Carbon Canister)—S/N Prior to 12071770. . . . .	5-28
Fuel Tank Service Parts—S/N 12071770 & Higher . . . . .	5-30
Fuel Tank Service Parts—S/N Prior to 12071770. . . . .	5-31
Engine Guard. . . . .	5-32

# Engine, Kawasaki FX850V-S/N 12031753 & Higher

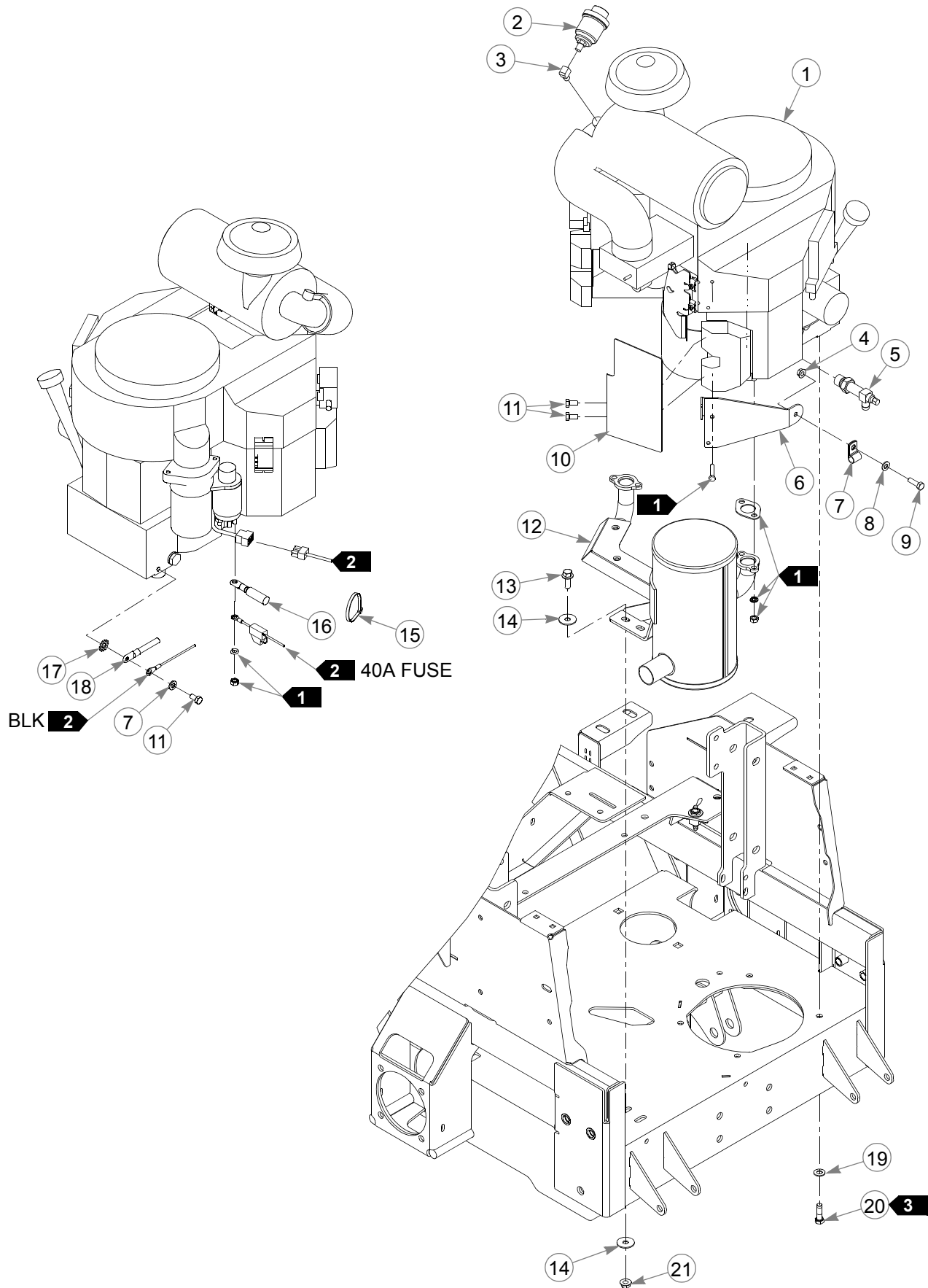

---

## **Engine, Kawasaki FX850V–S/N 12031753 & Higher**

INDEX NO.	PART NO.	QTY.	DESCRIPTION
1	N/A	1	KAWASAKI FX850V ENGINE
2	788943	1	AIR FILTER INDICATOR
3	601216	1	ELBOW STREET FITTING
4	016832	1	NT .312-18 HX FLK ZNYC
5	796524	1	OIL DRAIN VALVE
6	115652	1	LIFT HOOK
7	000398	2	LOOP CLAMP
8	768523	2	FW .343 X .687 X .051/.080H
9	036236	1	CS .312-18 X 1.00 HX G5
10	113714	1	SHIELD
11	720516	3	CS M8 X 1.25 X 16 HX G10.9
12	603924	1	MUFFLER
13	029751	2	CS .375-16 X 1.00 HXFLK
14	705137	4	FW .391 X 1.25 X .060 ZNY
15	000331	2	WIRE TIE
16	604025	1	POSITIVE BATTERY CABLE
17	029876	1	LW .312 INT-EXT TOOTH
18	604026	1	NEGATIVE BATTERY CABLE
19	767954	4	FW .406 X .812 X .060 SAE
20	602580	4	CS .375-16 X 1.25 HX G5 P85
21	016899	2	NT .375-16 HX FLK ZNYC

---

### **NOTES:**

1. Supplied with the engine.
2. Part of the wire harness.
3. Torque the bolt to 30 ft-lbs. Replace (do not reuse) the cap screw if it's removed or loosened. Use only hand tools to install this fastener.

**Engine, Kawasaki FX850V-S/N 12031753 & Higher**

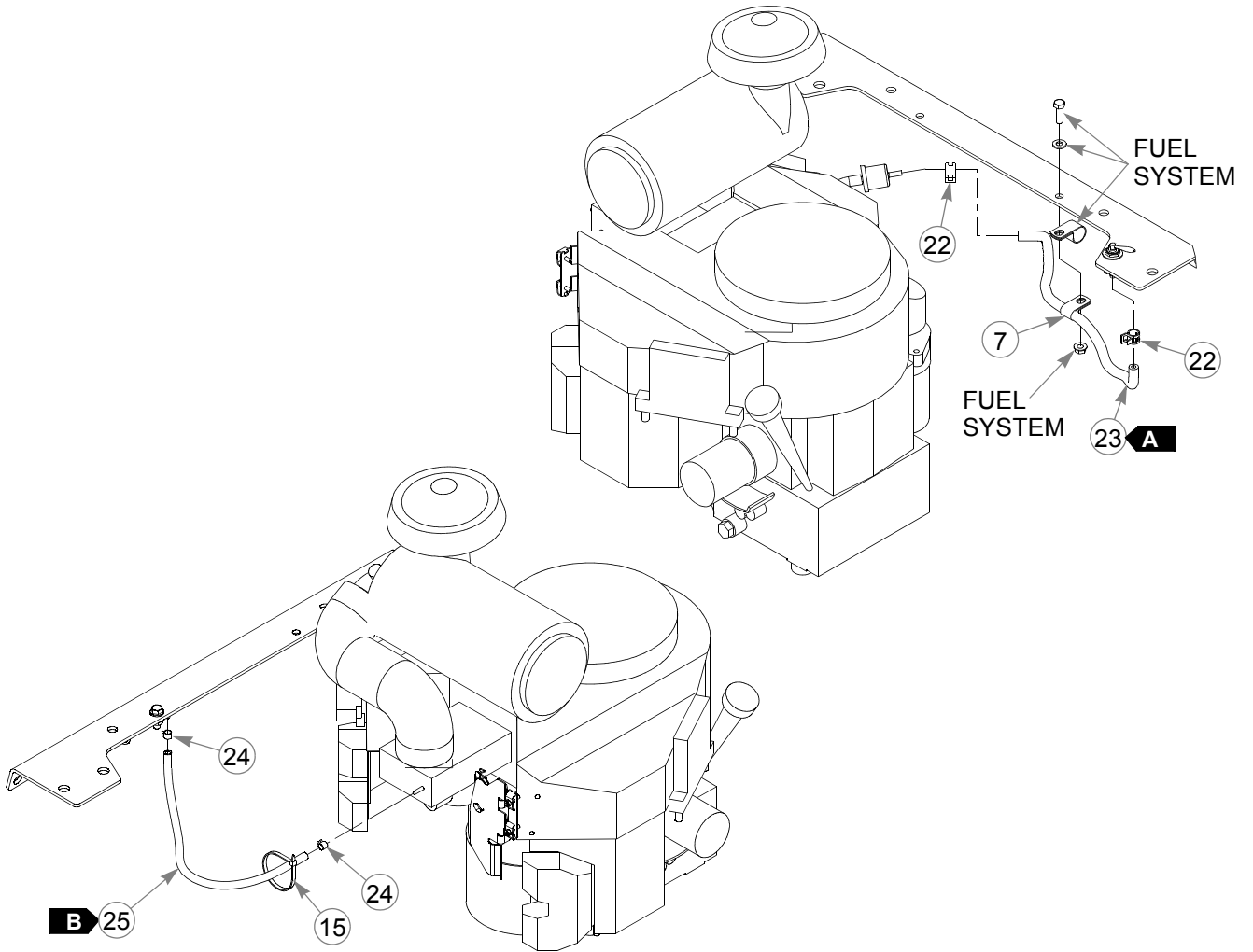

---

## **Engine, Kawasaki FX850V–S/N 12031753 & Higher**

INDEX NO.	PART NO.	QTY	DESCRIPTION
22	000323	2	HOSE CLAMP
23	015818	12"	1/4" FUEL LINE
24	603112	2	CLAMP, 3/16"
25	603326	22"	3/16" VAPOR LINE

---

### **NOTES:**

<b>FUEL &amp; VAPOR LINE LENGTHS</b>		
<b>A</b> ➤	12"	FUEL FILTER TO VALVE (FUEL)
<b>B</b> ➤	22"	TEE TO ENGINE (VAPOR)

# **Engine, Kawasaki FX850V-S/N Prior to 12031753**

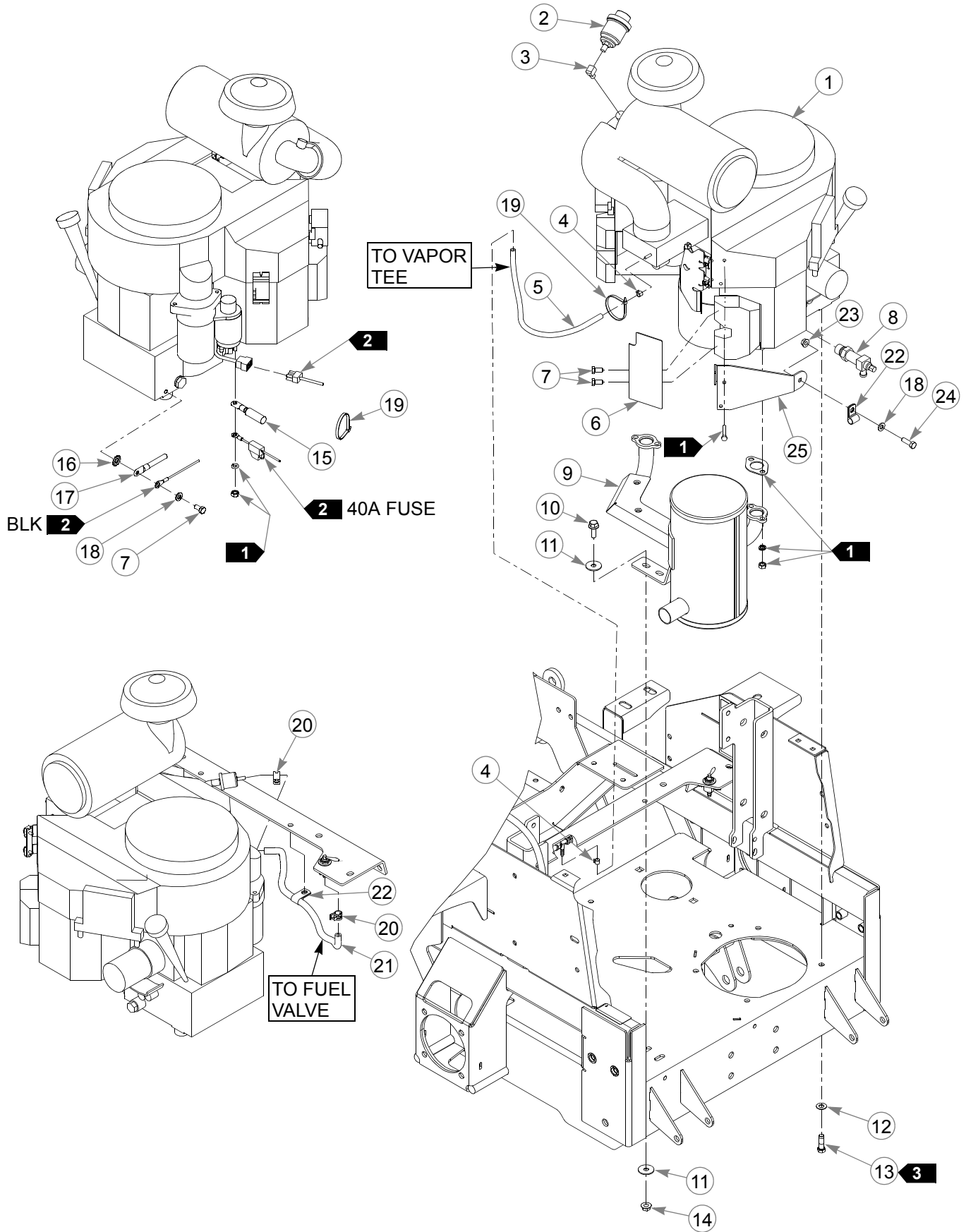



---

## **Engine, Kawasaki FX850V–S/N Prior to 12031753**

INDEX NO.	PART NO.	QTY.	DESCRIPTION
1	N/A	1	KAWASAKI FX850V ENGINE
2	788943	1	AIR FILTER INDICATOR
3	601216	1	ELBOW STREET FITTING
4	603112	2	CLAMP, 3/16"
5	603326	22"	3/16" VAPOR LINE
6	113714	1	SHIELD
7	720516	3	CS M8 X 1.25 X 16 HX G10.9
8	796524	1	OIL DRAIN VALVE
9	603924	1	MUFFLER
10	029751	2	CS .375-16 X 1.00 HXFLK
11	705137	4	FW .391 X 1.25 X .060 ZNY
12	767954	4	FW .406 X .812 X .060 SAE
13	602580	4	CS .375-16 X 1.25 HX G5 P85
14	016899	2	NT .375-16 HX FLK ZNYC
15	786632	1	RED POSITIVE BATTERY CABLE
16	029876	1	LW .312 INT-EXT TOOTH
17	796219	1	NEGATIVE BATTERY CABLE
18	768523	2	FW .343 X .687 X .051/.080H
19	000331	2	WIRE TIE
20	000323	2	HOSE CLAMP
21	015818	12"	1/4" FUEL LINE
22	000398	2	LOOP CLAMP
23	016832	1	NT .312-18 HX FLK ZNYC
24	036236	1	CS .312-18 X 1.00 HX G5
25	115652	1	LIFT HOOK

---

### **NOTES:**

1. Supplied with the engine.
2. Part of the wire harness.
3. Torque the bolt to 30 ft-lbs. Replace (do not reuse) the cap screw if it's removed or loosened. Use only hand tools to install this fastener.

# **Engine Service Parts, Kawasaki FX850V**

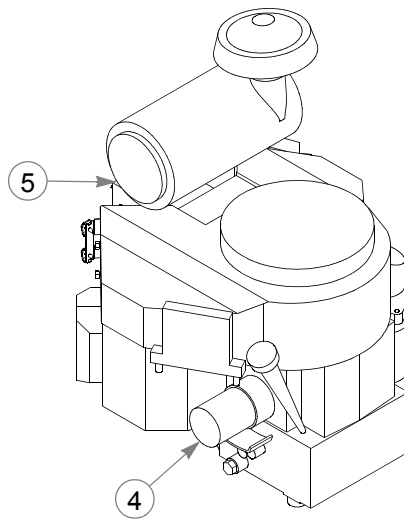
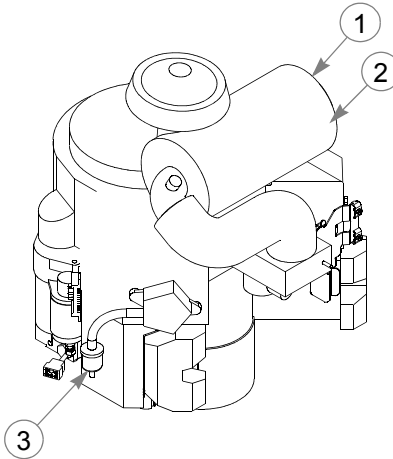

---

INDEX NO.	PART NO.	QTY.	DESCRIPTION
1	785261	1	MAIN AIR FILTER
2	785279	1	SAFETY AIR FILTER
3	068478	1	IN-LINE FUEL FILTER
4	603138	1	OIL FILTER
5	763318	1	VACTUATOR VALVE

---

## **NOTES:**

---

**This page intentionally left blank.**

# **Engine, Kawasaki FX1000V-S/N 12031753 & Higher**

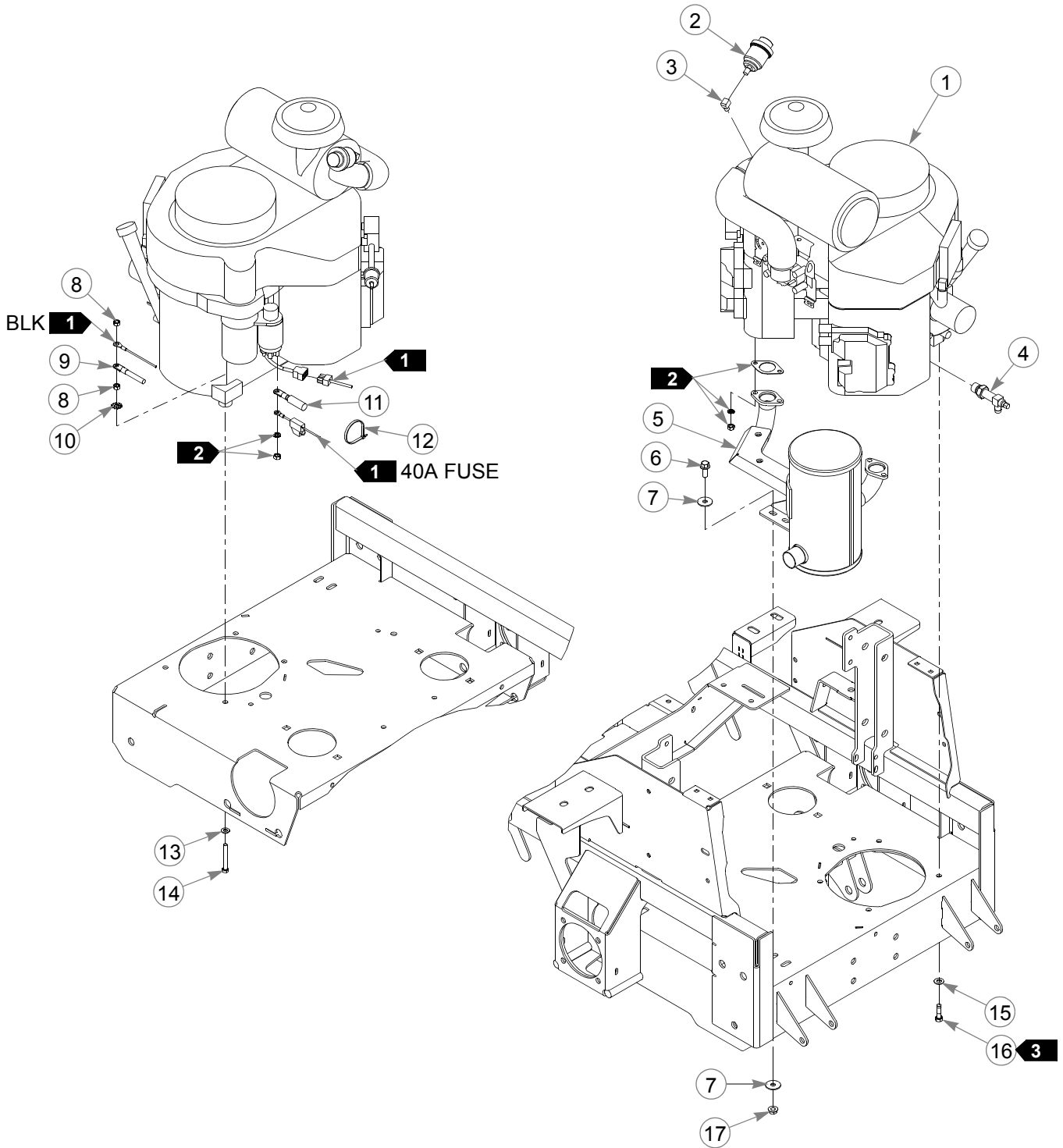

---

## **Engine, Kawasaki FX1000V–S/N 12031753 & Higher**

INDEX NO.	PART NO.	QTY.	DESCRIPTION
1	N/A	1	KAWASAKI FX1000V ENGINE
2	788943	1	AIR FILTER INDICATOR
3	601216	1	ELBOW STREET FITTING
4	796524	1	OIL DRAIN VALVE
5	603925	1	MUFFLER
6	029751	2	CS .375-16 X 1.00 HXFLK
7	705137	4	FW .391 X 1.25 X .060 ZNY
8	034272	2	NT .312-18 HX G5 ZNYC
9	604026	1	NEGATIVE BATTERY CABLE
10	029876	1	LW .312 INT-EXT TOOTH
11	604025	1	POSITIVE BATTERY CABLE
12	000331	2	WIRE TIE
13	768523	1	FW .343 X .687 X .051/.080H
14	710087	1	CS .312-18 X 2.50 HX G5
15	767954	3	FW .406 X .812 X .060 SAE
16	602580	3	CS .375-16 X 1.25 HX G5 P85
17	016899	2	NT .375-16 HX FLK ZNYC

---

### **NOTES:**

1. Part of the wire harness.
2. Supplied with the engine.
3. Torque the bolt to 30 ft-lbs. Replace (do not reuse) the cap screw if it's removed or loosened. Use only hand tools to install this fastener.

# Engine, Kawasaki FX1000V-S/N 12031753 & Higher

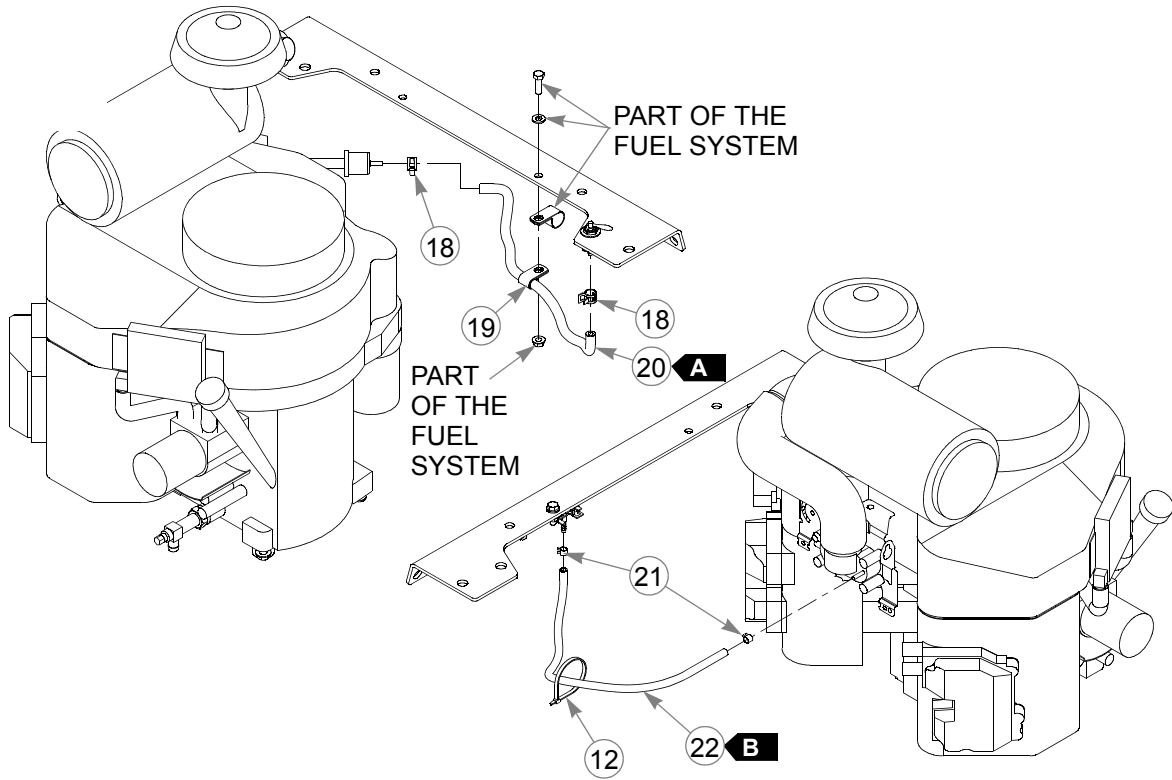

INDEX NO.	PART NO.	QTY	DESCRIPTION
18	000323	2	HOSE CLAMP
19	000398	1	LOOP CLAMP
20	015818	12"	1/4" FUEL LINE
21	603112	2	CLAMP, 3/16"
22	603326	23"	3/16" VAPOR LINE

## NOTES:

FUEL & VAPOR LINE LENGTHS		
<b>A</b>	12"	ENGINE TO VALVE (FUEL)
<b>B</b>	23"	ENGINE TO TEE (VAPOR)

---

**This page intentionally left blank.**

# Engine, Kawasaki FX1000V-S/N Prior to 12031753

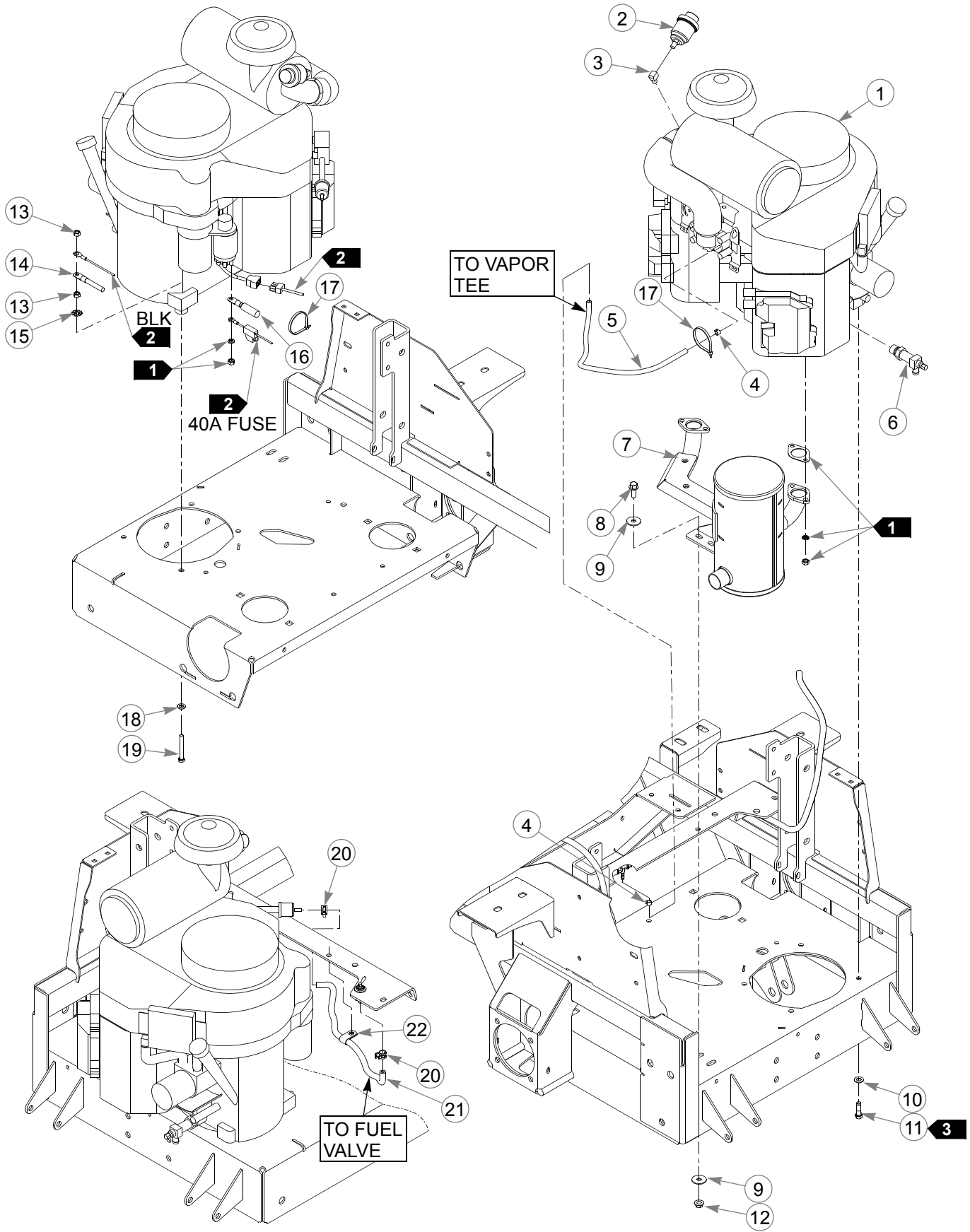



---

## ***Engine, Kawasaki FX1000V–S/N Prior to 12031753***

INDEX NO.	PART NO.	QTY.	DESCRIPTION
1	N/A	1	KAWASAKI FX1000V ENGINE
2	788943	1	AIR FILTER INDICATOR
3	601216	1	ELBOW STREET FITTING
4	603112	2	CLAMP, 3/16"
5	603326	23"	3/16" VAPOR LINE
6	796524	1	OIL DRAIN VALVE
7	603925	1	MUFFLER
8	029751	2	CS .375-16 X 1.00 HXFLK
9	705137	4	FW .391 X 1.25 X .060 ZNY
10	767954	3	FW .406 X .812 X .060 SAE
11	602580	3	CS .375-16 X 1.25 HX G5 P85
12	016899	2	NT .375-16 HX FLK ZNYC
13	034272	2	NT .312-18 HX G5 ZNYC
14	796219	1	NEGATIVE BATTERY CABLE
15	029876	1	LW .312 INT-EXT TOOTH
16	786632	1	RED POSITIVE BATTERY CABLE
17	000331	2	WIRE TIE
18	768523	1	FW .343 X .687 X .051/.080H
19	710087	1	CS .312-18 X 2.50 HX G5
20	000323	2	HOSE CLAMP
21	015818	12"	1/4" FUEL LINE
22	000398	1	LOOP CLAMP

---

### **NOTES:**

1. Supplied with the engine.
2. Part of the wire harness.
3. Torque the bolt to 30 ft-lbs. Replace (do not reuse) the cap screw if it's removed or loosened. Use only hand tools to install this fastener.

# Engine Service Parts, Kawasaki FX1000V

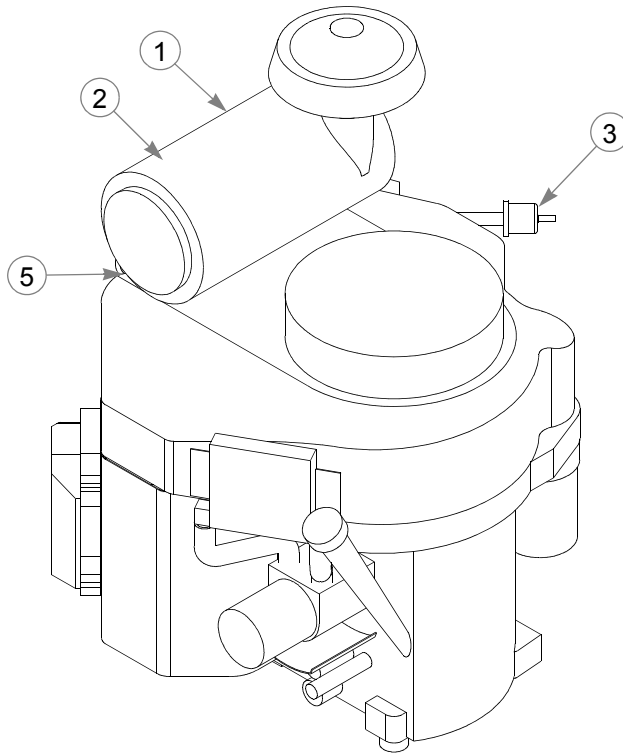

---

INDEX NO.	PART NO.	QTY.	DESCRIPTION
1	785261	1	MAIN AIR FILTER
2	785279	1	SAFETY AIR FILTER
3	068478	1	IN-LINE FUEL FILTER
4	603138	1	OIL FILTER
5	763318	1	VACTUATOR VALVE

---

## NOTES:

---

**This page intentionally left blank.**

# **Fuel System (w/ Carbon Canister)—S/N 12071770 & Higher**

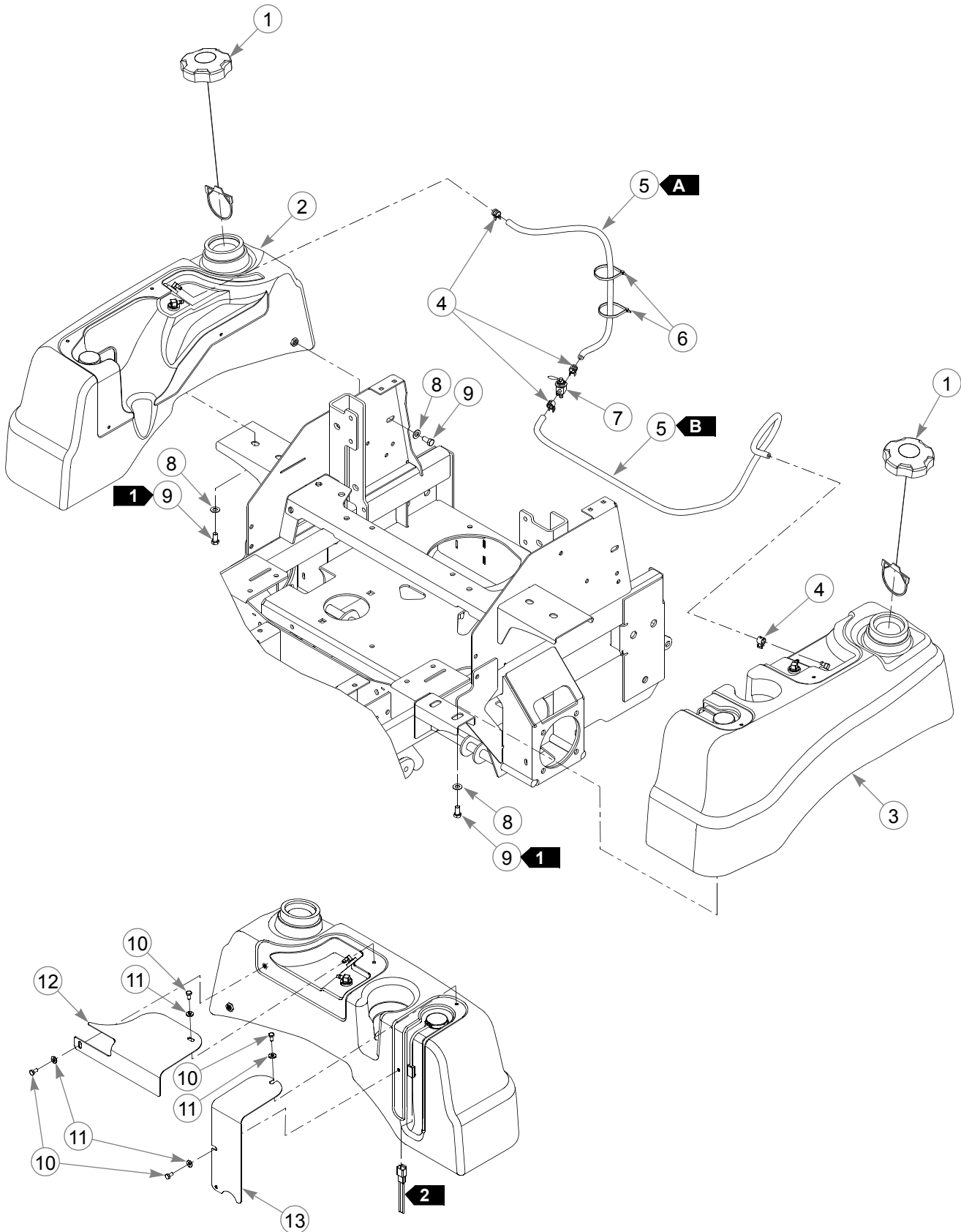

---

## **Fuel System (w/ Carbon Canister)—S/N 12071770 & Higher**

INDEX NO.	PART NO.	QTY.	DESCRIPTION
1	603807	2	RATCHETING GAS CAP 3.5"
2	603801	1	RS FUEL TANK ASSEMBLY
3	603802	1	LS FUEL TANK ASSEMBLY
4	000323	12	HOSE CLAMP
5	015818	149"	1/4" FUEL LINE
6	000331	3	WIRE TIE, SMALL/SHORT
7	745059	1	FUEL VALVE 3-WAY
8	767954	10	FW .406 X .812 X .060 SAE
9	055822	10	CS .375-16 X .750 HX G5
10	055947	4	CS .250-20 X .50 HX G5
11	768515	4	FW .281 X .625 X .051/.080H
12	115998	1	TANK COVER
13	115999	1	TANK COVER

---

### **NOTES:**

1. Torque to 20 ft-lbs.
2. Part of the wire harness.

<b>FUEL LINE LENGTHS</b>		
<b>A</b>	21"	RIGHT TANK TO VALVE (FUEL)
<b>B</b>	44"	LEFT TANK TO VALVE (FUEL)

**Vapor System (w/ Carbon Canister)—S/N 12071770 & Higher**

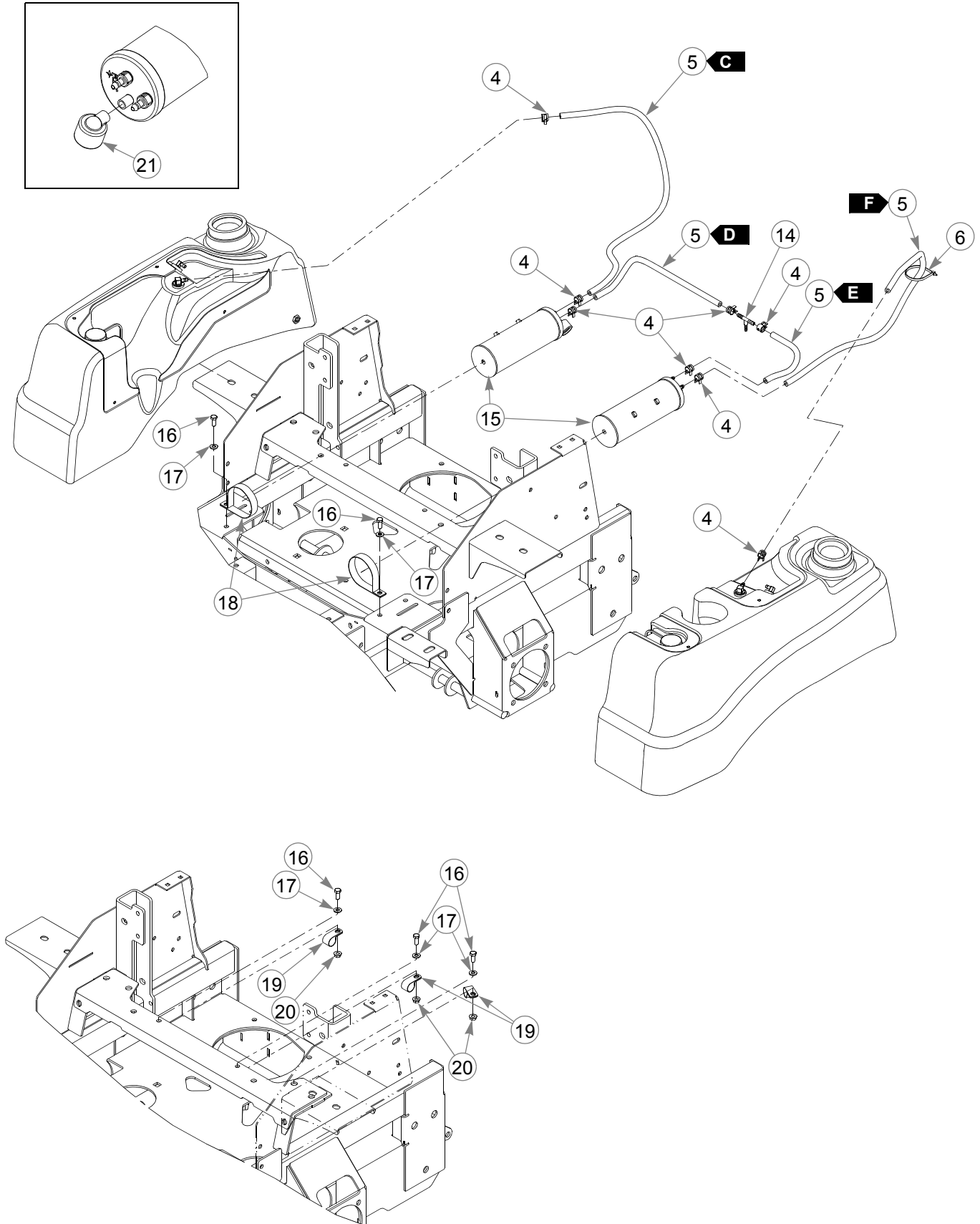

# Vapor System (w/ Carbon Canister)—S/N 12071770 & Higher

INDEX NO.	PART NO.	QTY.	DESCRIPTION
14	603025	1	PLASTIC TEE 1/4" X 1/4" X 3/16"
15	602982	2	CARBON CANISTER
16	036236	7	CS .312-18 X 1.00 HX G5
17	768523	7	FW .343 X .687 X .051/.080H
18	602980	4	3.0" CUSHIONED CLAMP
19	043570	3	LOOP CLAMP
20	016832	7	NT .312-18 HXFLK ZNYC
21	603161	1	VACUUM BREAKER FILTER

## NOTES:

VAPOR LINE LENGTHS		
<b>C</b>	30"	RIGHT TANK TO RIGHT CARBON CANISTER (VAPOR)
<b>D</b>	15"	RIGHT CARBON CANISTER TO TEE (VAPOR)
<b>E</b>	9"	LEFT CARBON CANISTER TO TEE (VAPOR)
<b>F</b>	30"	LEFT TANK TO LEFT CARBON CANISTER (VAPOR)

**Fuel System (w/ Carbon Canister)–S/N Prior to 12071770**

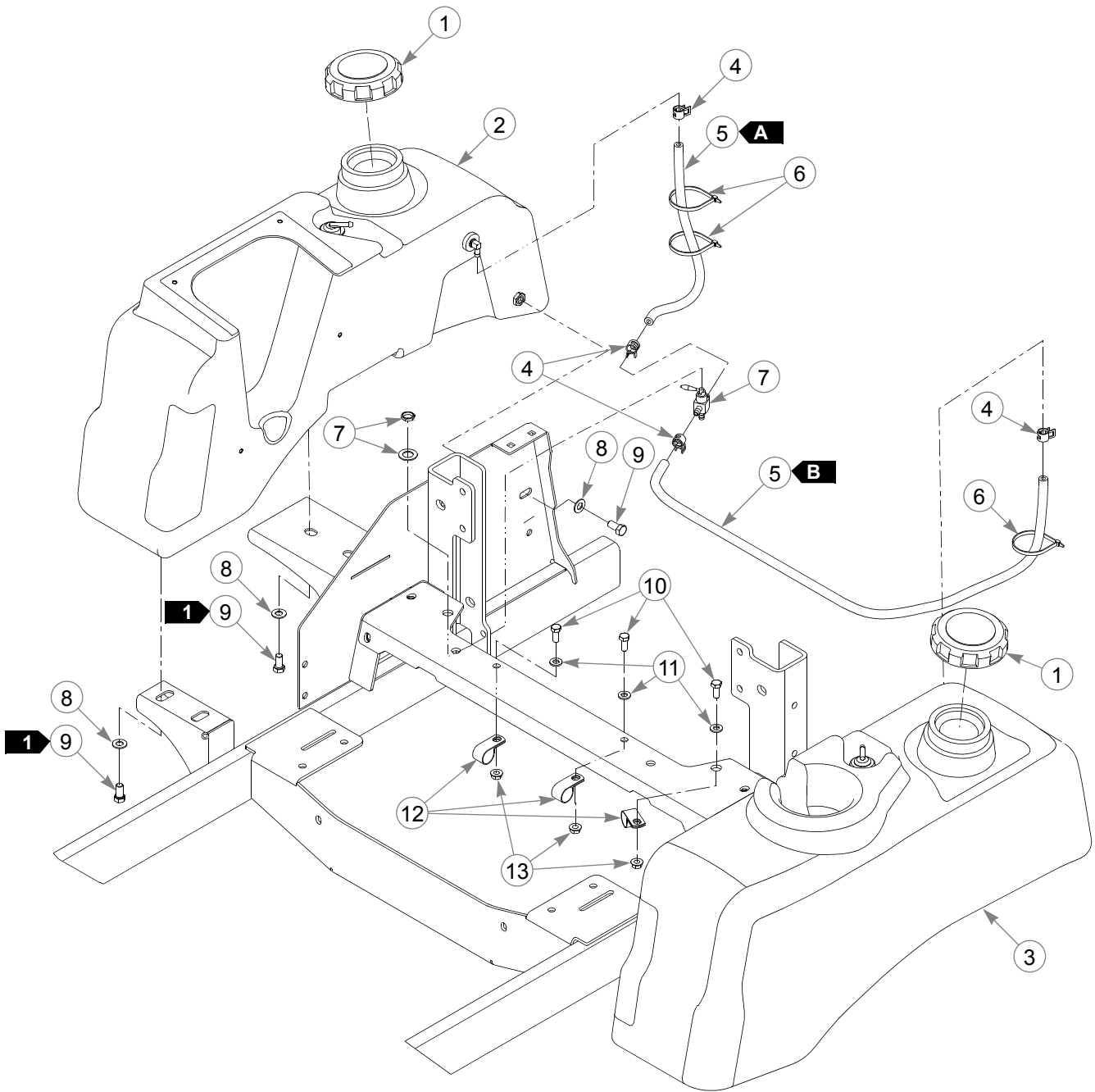



---

## **Fuel System (w/ Carbon Canister)–S/N Prior to 12071770**

INDEX NO.	PART NO.	QTY.	DESCRIPTION
1	602916	2	RATCHETING GAS CAP, 3.5"
2	603142	1	RS FUEL TANK ASSEMBLY
3	603143	1	LS FUEL TANK ASSEMBLY
4	000323	12	HOSE CLAMP
5	015818	130"	1/4" FUEL LINE
6	000331	3	WIRE TIE, SMALL/SHORT
7	745059	1	FUEL VALVE 3-WAY
8	767954	10	FW .406 X .812 X .060 SAE
9	055822	10	CS .375-16 X .75 HX G5
10	034280	7	CS .312-18 X .75 HX G5
11	768523	7	FW .343 X .687 X .051/.080H
12	043570	3	LOOP CLAMP
13	016832	7	NT .312-18 HXFLK ZNYC

---

### **NOTES:**

1. Torque to 20 ft-lbs.

<b>FUEL LINE LENGTHS</b>		
<b>A</b>	12"	RIGHT TANK TO VALVE (FUEL)
<b>B</b>	36"	LEFT TANK TO VALVE (FUEL)

# Vapor System (w/ Carbon Canister)–S/N Prior to 12071770

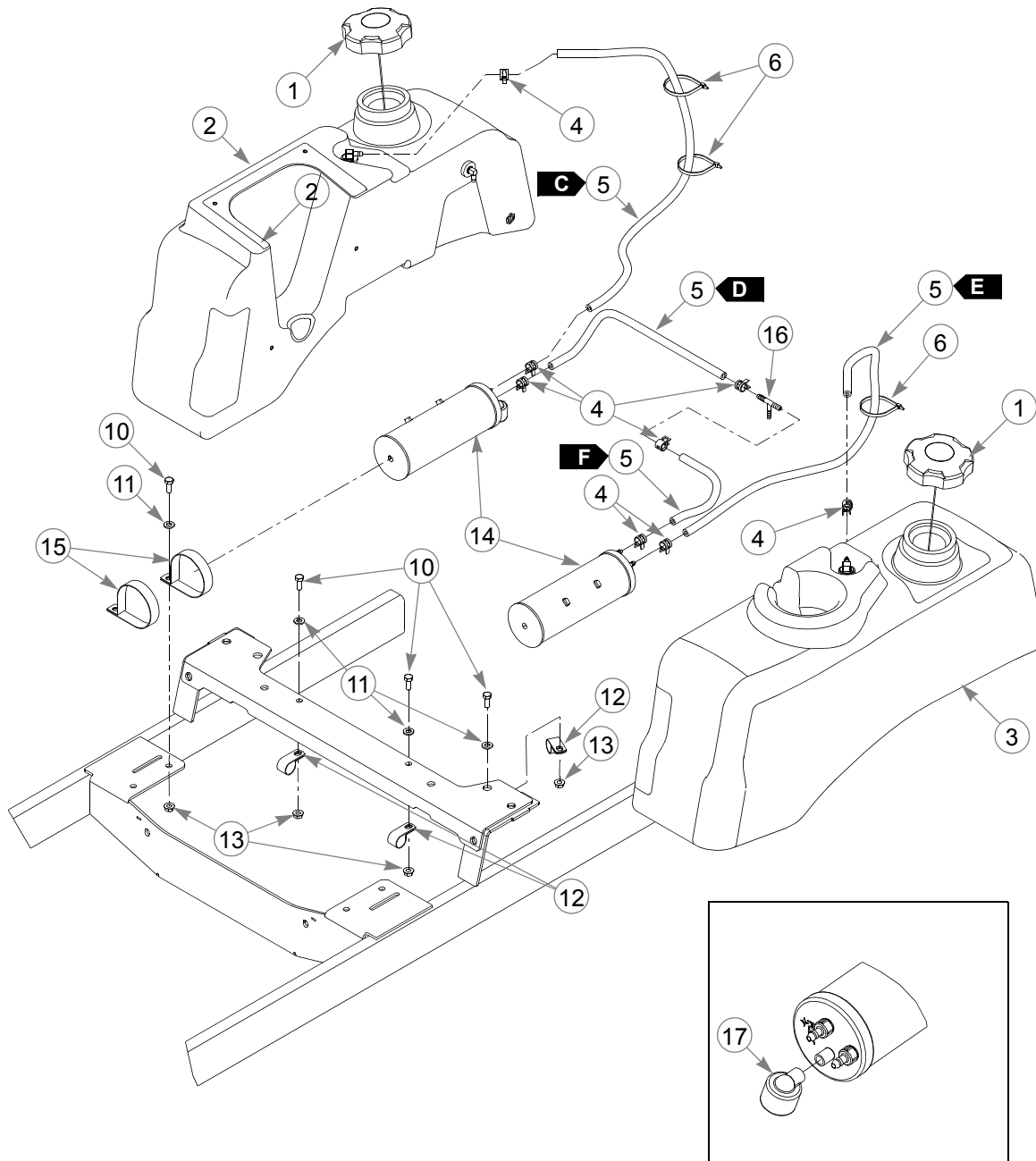

---





## **Vapor System (w/ Carbon Canister)–S/N Prior to 12071770**

---

INDEX NO.	PART NO.	QTY.	DESCRIPTION
14	602982	2	CARBON CANISTER, 9 GAL.
15	602980	4	3.0" CUSHIONED CLAMP
16	603025	1	PLASTIC TEE, 1/4"
17	603161	1	VACUUM BREAKER FILTER

---

### **NOTES:**

<b>VAPOR LINE LENGTHS</b>		
	28"	RIGHT TANK TO RIGHT CARBON CANISTER (VAPOR)
	15"	RIGHT CARBON CANISTER TO TEE (VAPOR)
	30"	LEFT TANK TO LEFT CARBON CANISTER (VAPOR)
	9"	LEFT CARBON CANISTER TO TEE (VAPOR)

# Fuel System—S/N 12071770 & Higher

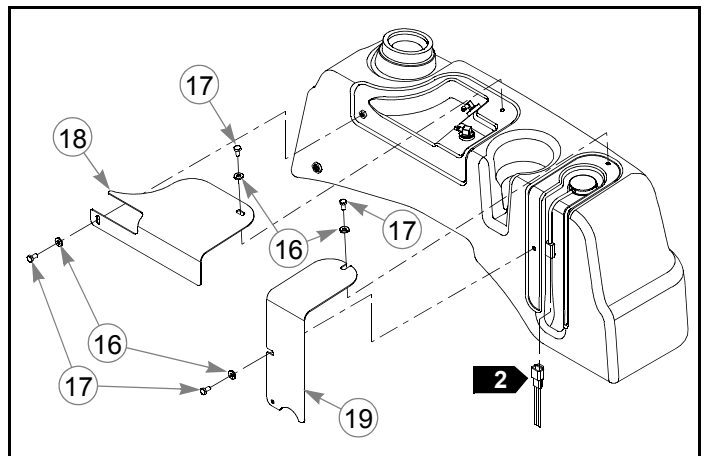
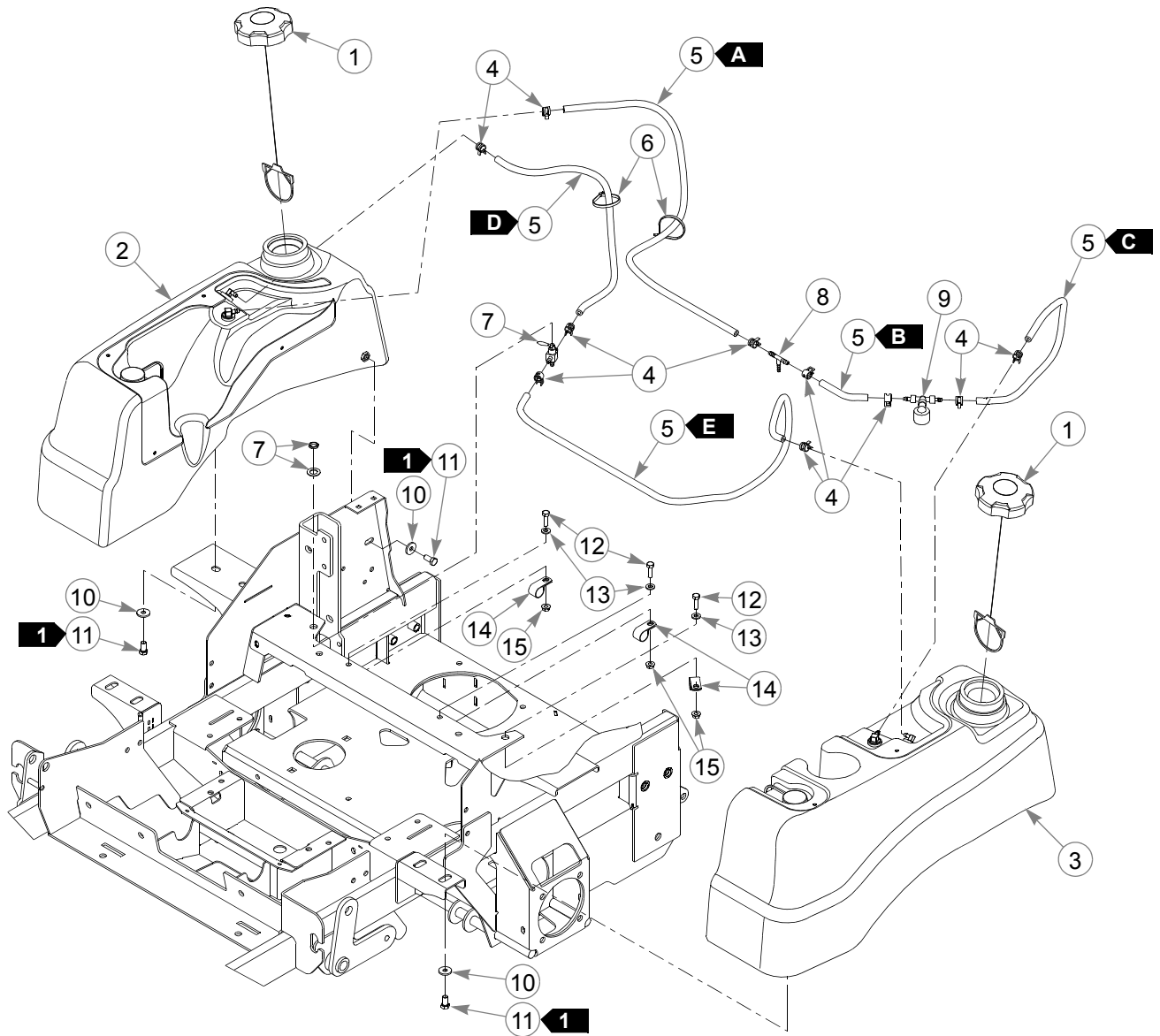

# Fuel System–S/N 12071770 & Higher

INDEX NO.	PART NO.	QTY.	DESCRIPTION
1	603807	2	RATCHETING GAS CAP 3.5"
2	603801	1	RS FUEL TANK ASSEMBLY
3	603802	1	LS FUEL TANK ASSEMBLY
4	000323	10	HOSE CLAMP
5	015818	128"	1/4" FUEL LINE
6	000331	3	WIRE TIE
7	745059	1	FUEL VALVE 3-WAY
8	603025	1	PLASTIC TEE 1/4" X 1/4" X 3/16"
9	603024	1	VACUUM BREAKER (WITH FILTER)
10	712927	10	FW .344 X 1.00 X .12 HRD Z
11	055822	10	CS .375-16 X .75 HX G5
12	036236	3	CS .312-18 X 1.00 HX G5
13	768523	3	FW .343 X .687 X .051/.080H
14	043570	3	LOOP CLAMP
15	016832	3	NT .312-18 HX FLK ZNYC
16	768515	4	FW .281 X .625 X .051/.080H
17	055947	4	CS .250-20 X .50 HX G5
18	115998	1	TANK COVER
19	115999	1	TANK COVER

## NOTES:

FUEL LINE LENGTHS		
<b>A</b>	36"	RIGHT TANK TO TEE (VAPOR)
<b>B</b>	5"	TEE TO VACUUM BREAKER (VAPOR)
<b>C</b>	22"	LEFT TANK TO VACUUM BREAKER (VAPOR)
<b>D</b>	21"	RIGHT TANK TO VALVE (FUEL)
<b>E</b>	44"	LEFT TANK TO VALVE (FUEL)

1. Torque to 20 ft-lbs.
2. Part of the wire harness.

# Fuel System (w/o Carbon Canister)–S/N Prior to 12071770

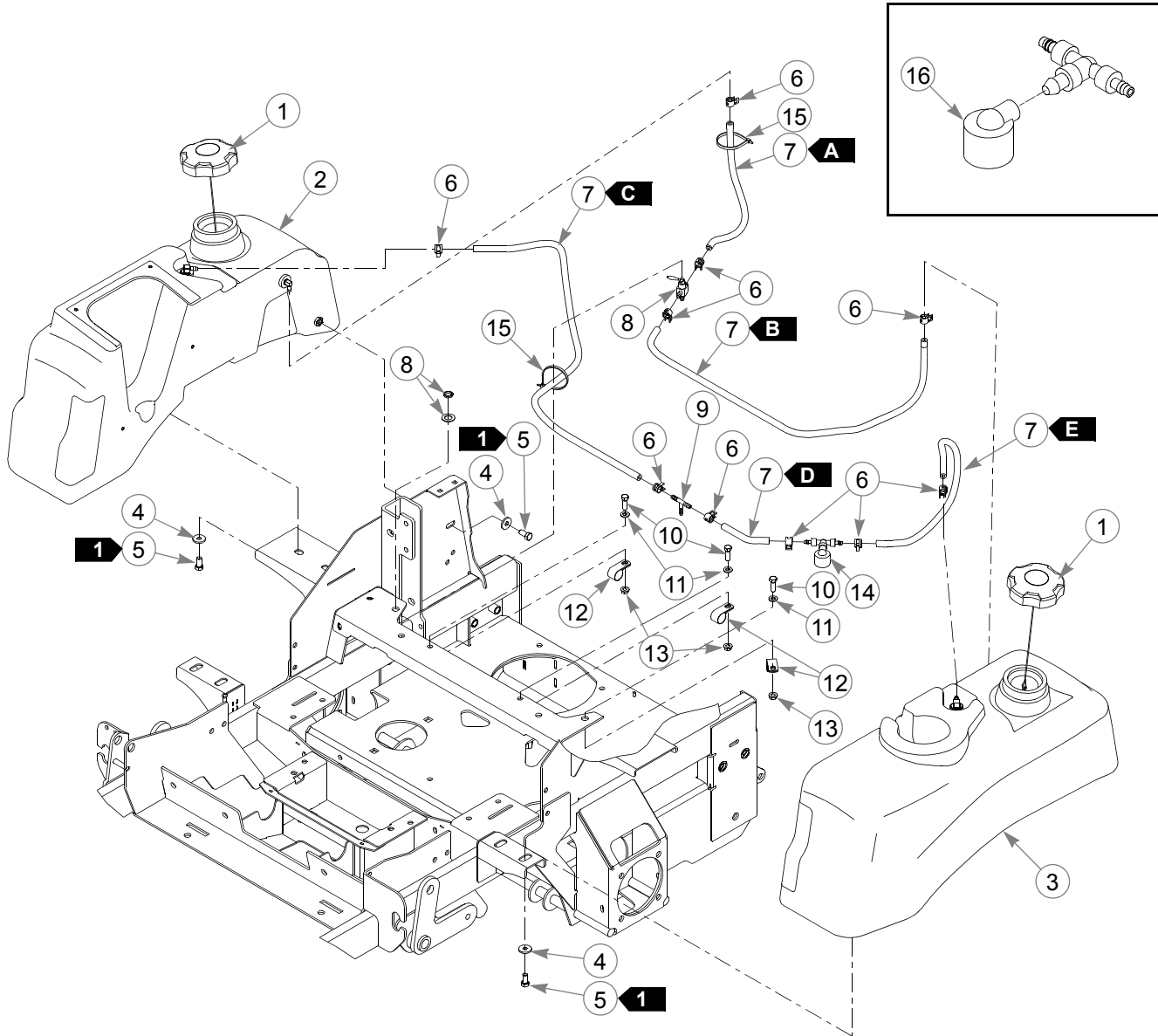

---

## **Fuel System (w/o Carbon Canister)–S/N Prior to 12071770**

INDEX NO.	PART NO.	QTY.	DESCRIPTION
1	602916	2	RATCHETING GAS CAP 3.5"
2	603142	1	RS FUEL TANK ASSEMBLY
3	603143	1	LS FUEL TANK ASSEMBLY
4	712927	10	FW .344 X 1.00 X .12 HRD Z
5	055822	10	CS .375-16 X .75 HX G5
6	000323	10	HOSE CLAMP
7	015818	110"	1/4" FUEL LINE
8	745059	1	FUEL VALVE 3-WAY
9	603025	1	PLASTIC TEE 1/4" X 1/4" X 3/16"
10	036236	3	CS .312-18 X 1.00 HX G5
11	768523	3	FW .343 X .687 X .051/.080H
12	043570	3	LOOP CLAMP
13	016832	3	NT .312-18 HX FLK ZNYC
14	603024	1	VACUUM BREAKER
15	000331	2	WIRE TIE
16	603161	1	VACUUM BREAKER FILTER

---

### **NOTES:**

1. Torque to 20 ft-lbs.

<b>FUEL LINE LENGTHS</b>		
<b>A</b>	12"	RIGHT TANK TO VALVE (FUEL)
<b>B</b>	36"	LEFT TANK TO VALVE (FUEL)
<b>C</b>	36"	RIGHT TANK TO TEE (VAPOR)
<b>D</b>	5"	TEE TO VACUUM BREAKER (VAPOR)
<b>E</b>	21"	LEFT TANK TO VACUUM BREAKER (VAPOR)

## **Fuel Tank Service Parts—S/N 12071770 & Higher**

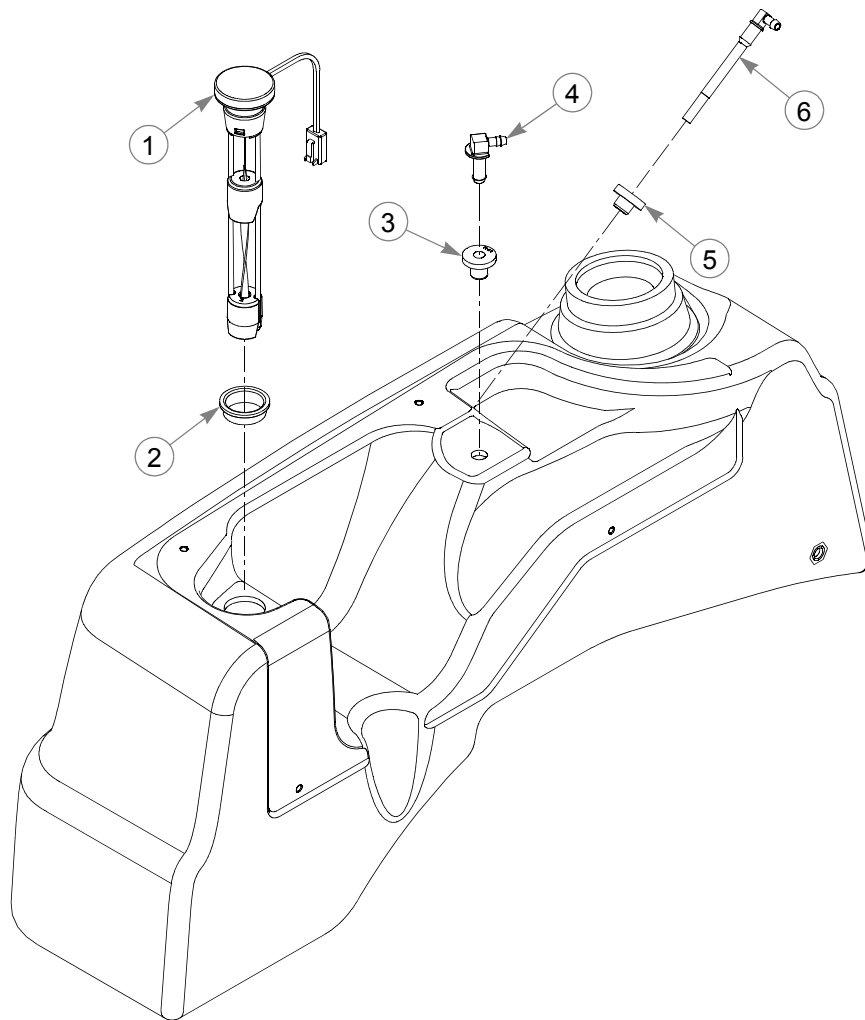

INDEX NO.	PART NO.	QTY.	DESCRIPTION
1	603888	1	FUEL SENDER
2	603889	1	GROMMET
3	604200	1	GROMMET
4	604199	1	FUEL VENT VALVE
5	785295	1	GROMMET
6	601805	1	SUCTION HOSE ASSEMBLY 22.0"

### **NOTES:**



---

## **Fuel Tank Service Parts—S/N Prior to 12071770**

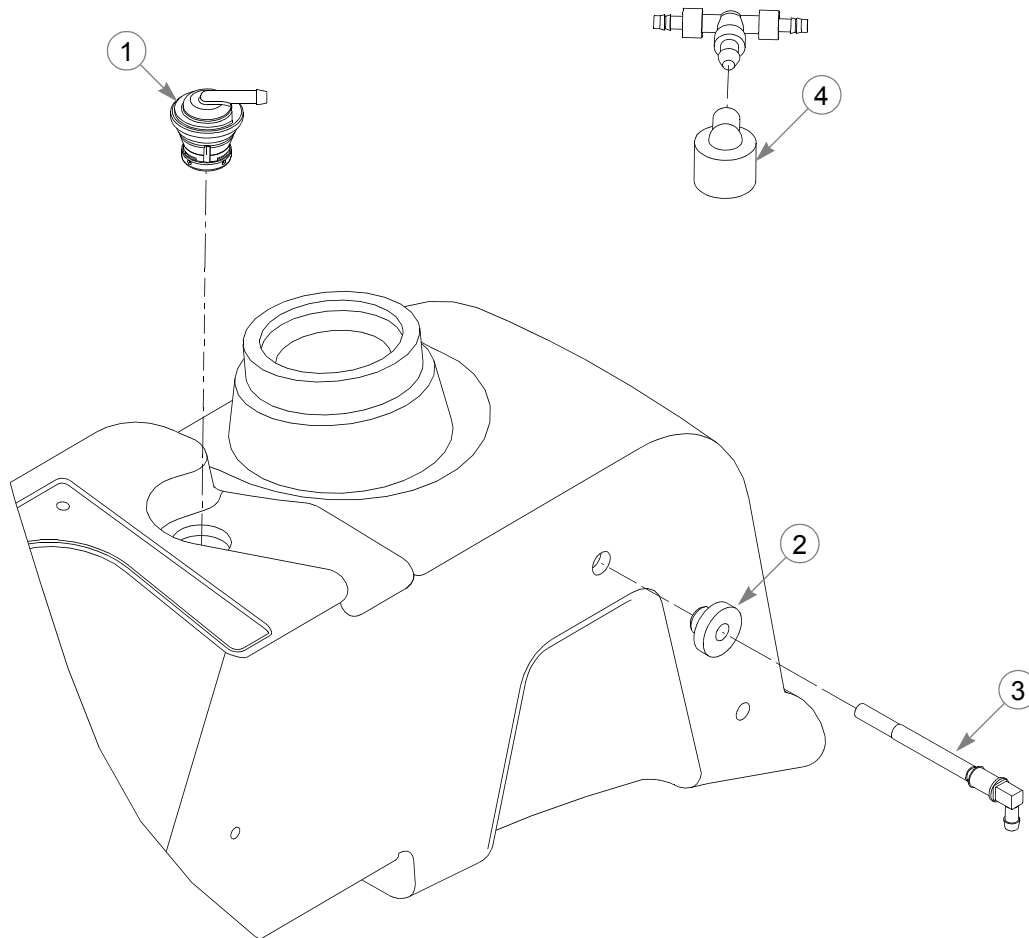

---

INDEX NO.	PART NO.	QTY.	DESCRIPTION
1	117118	1	VENT FITTING KIT
2	785295	1	SUCTION HOSE GROMMET
3	601530	1	SUCTION HOSE ASSEMBLY 33.5"
4	603161	1	VACUUM BREAKER FILTER

---

### **NOTES:**

# Engine Guard

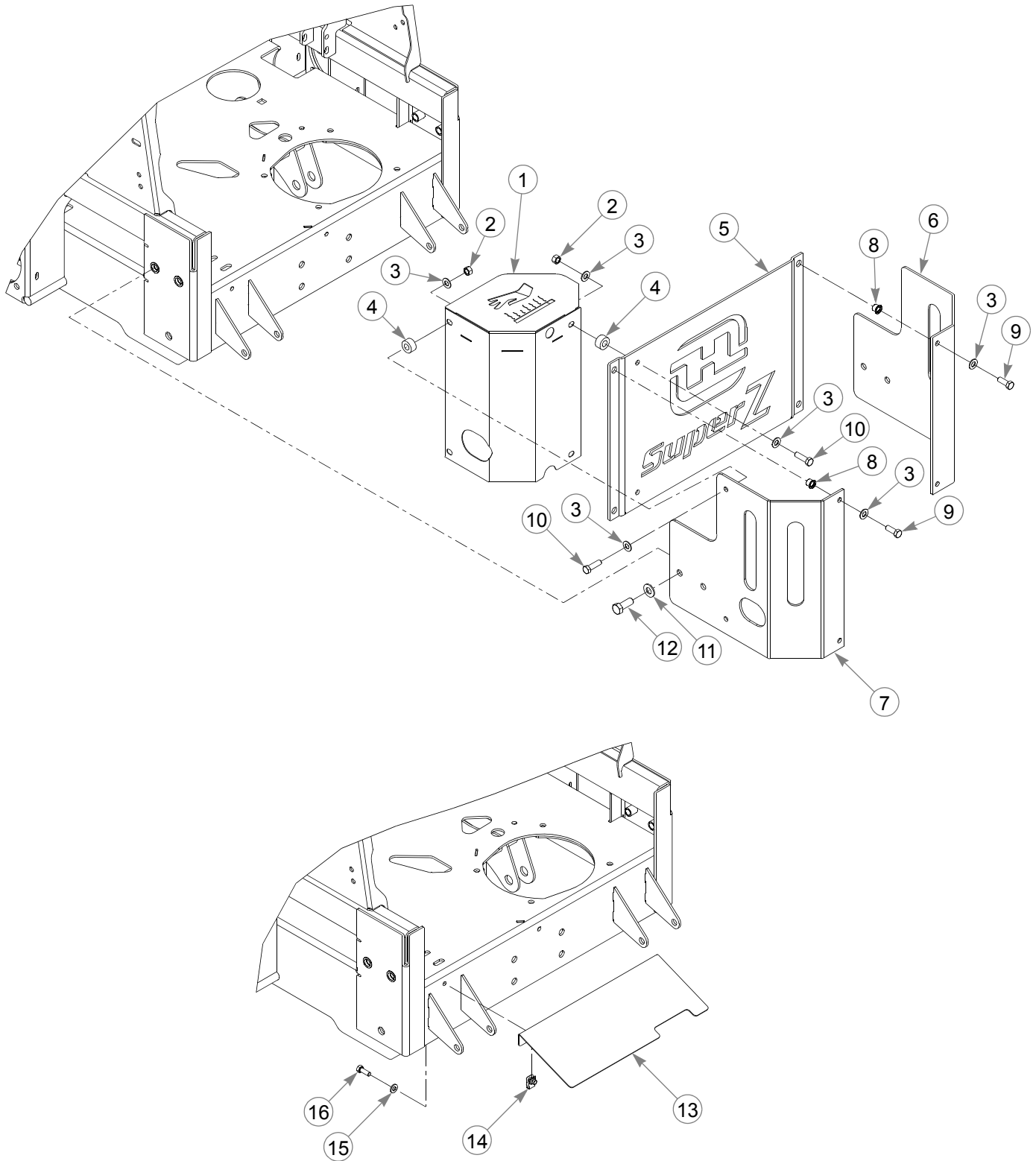

---

## **Engine Guard**

INDEX NO.	PART NO.	QTY.	DESCRIPTION
1	114036	1	SHIELD (USED ON MOWER WITH FX850V ENGINE)
	113429	1	SHIELD (USED ON MOWER WITH FX1000V ENGINE)
2	054502	4	NT .375-16 HX GRD 5 ZNY
3	767954	12	FW .406 X .812 X .060 SAE
4	603076	4	SHIELD SPACER
5	551169	1	ENGINE GUARD (WITH RIVET NUTS)
6	113843	1	RS BUMPER PANEL
7	113844	1	LS BUMPER PANEL
8	808493	4	3/8-16 THREAD RIVET NUT
9	036244	4	CS .375-16 X 1.00 HX G5
10	052860	4	CS .375-16 X 1.25 HX G5 ZN
11	767962	4	FW .531 X 1.063 X .090 SAE
12	705954	4	CS .500-13 X 1.25 HX G5 ZN
13	113858	1	DEFLECTOR
14	601069	2	CN .312-18 X .20 MAX THK
15	768523	2	FW .343 X .687 X .051/.080H
16	064014	2	CS .312-18 X .875 HX G5 ZN

---

### **NOTES:**



---

## Section 6

Battery—S/N 12031753 & Higher . . . . .	6-2
Battery—S/N Prior to 12031753 . . . . .	6-4
Instrument Panel—S/N 12071770 & Higher . . . . .	6-6
Instrument Panel—S/N Prior to 12071770 . . . . .	6-8

**Battery—S/N 12031753 & Higher**

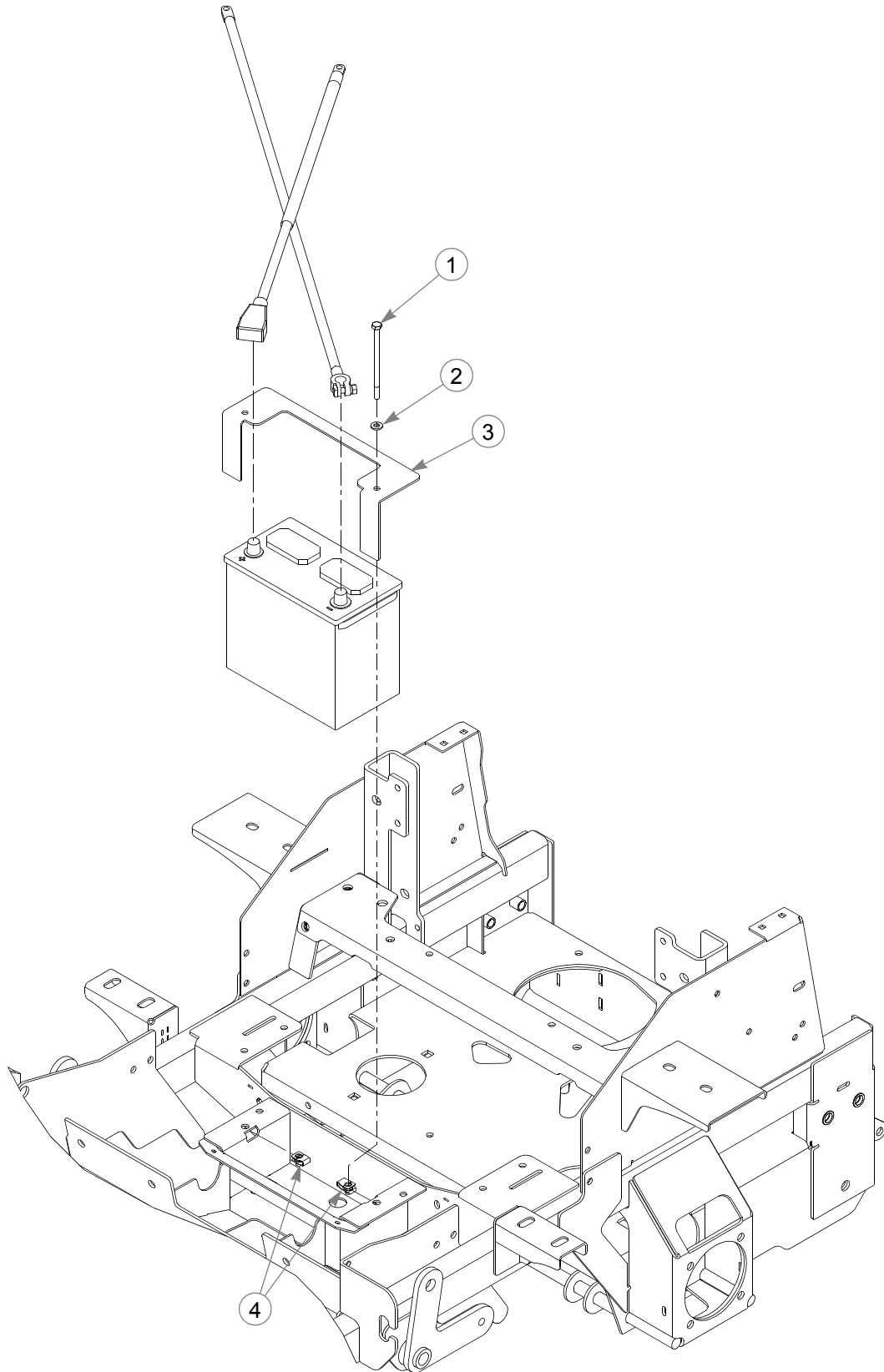

---

## **Battery—S/N 12031753 & Higher**

INDEX NO.	PART NO.	QTY.	DESCRIPTION
1	050823	2	CS .312-18 X 5.00 HX GR5
2	768523	2	FW .343 X .687 X .051/.080H
3	113676	1	BATTERY STRAP
4	601069	2	CN .312-18 X .20 MAX THK

---

### **NOTES:**

# **Battery—S/N Prior to 12031753**

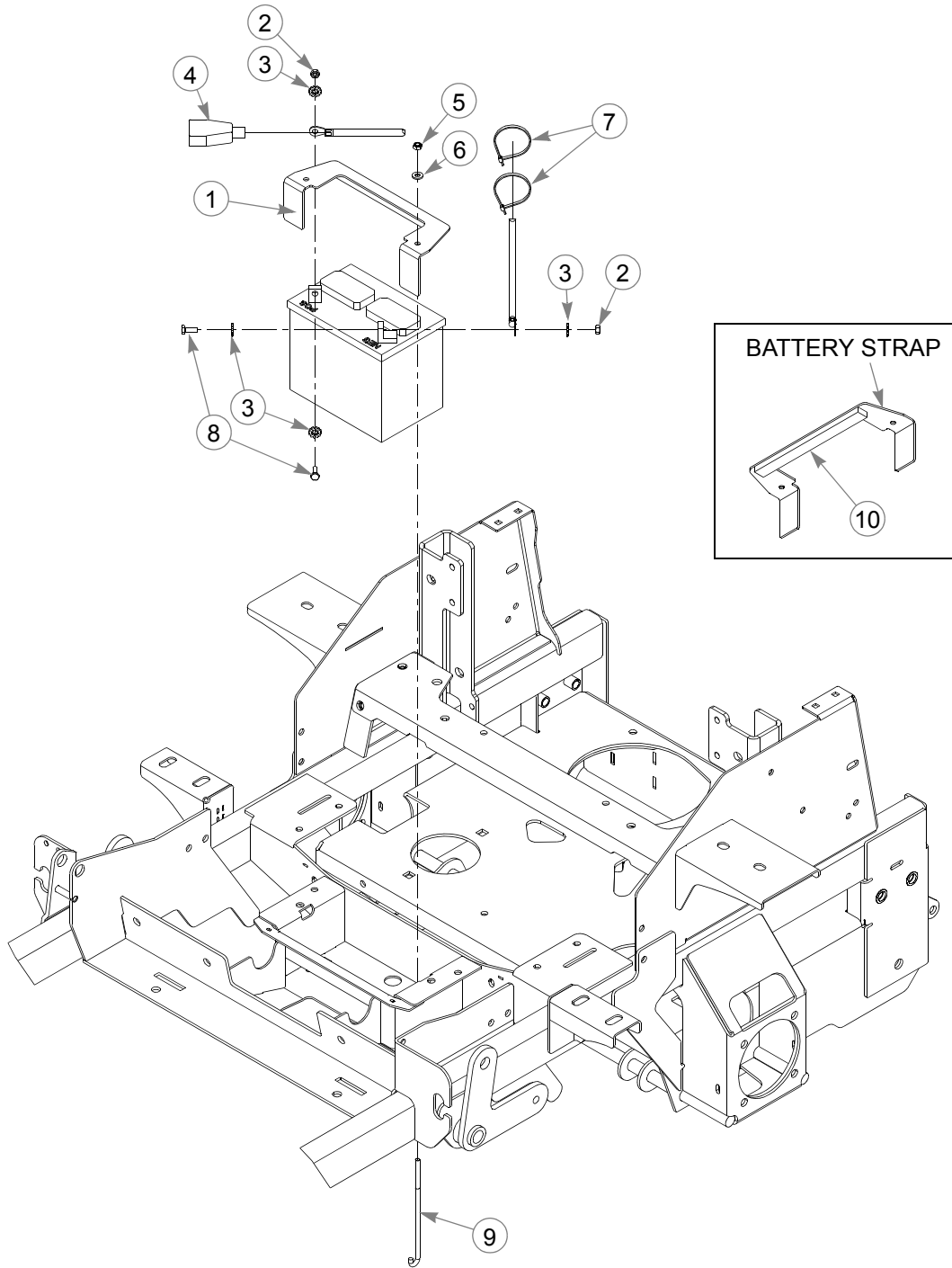



---

## **Battery—S/N Prior to 12031753**

INDEX NO.	PART NO.	QTY.	DESCRIPTION
1	113147	1	BATTERY STRAP
2	024927	2	NT .250-20 HX G5 ZNYC
3	029868	4	LW .250 INT-EXT TOOTH Z
4	771428	1	RED BATTERY CABLE BOOT
5	068551	2	NT .250-20 HX ZY NL
6	768515	2	FW .281 X .625 X .051/.080 HD ZN/YL
7	000331	3	WIRE TIE
8	055939	2	CS .250-20 X .75 HX G5
9	793489	2	BATTERY CLAMP ROD
10	713198	.7 ft	SEAL 3/8 X 3/4

---

### **NOTES:**

# Instrument Panel—S/N 12071770 & Higher

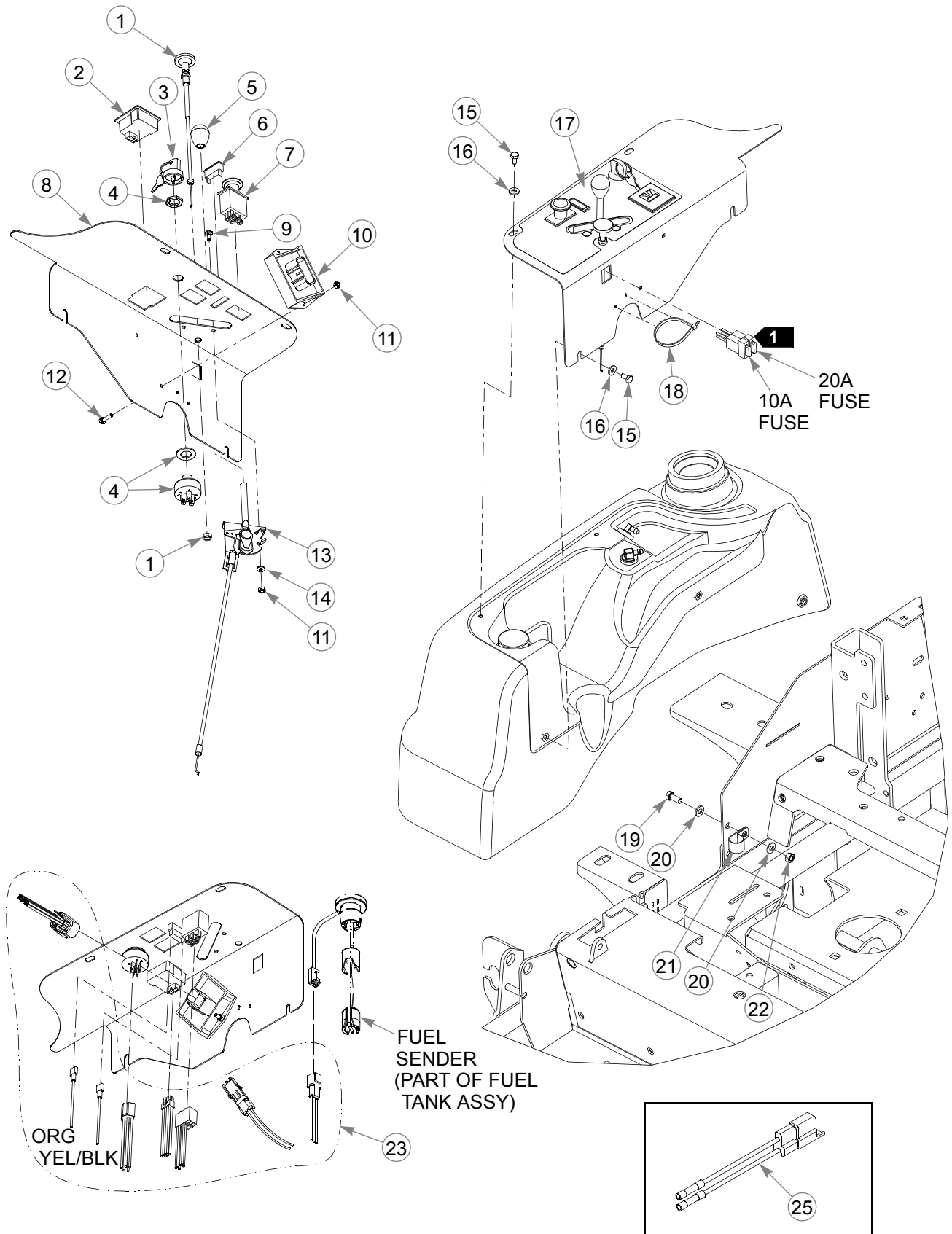

---

## **Instrument Panel–S/N 12071770 & Higher**

INDEX NO.	PART NO.	QTY.	DESCRIPTION
1	603087	1	CHOKE CABLE
2	603748	1	FUEL DISPLAY/HOUR METER
3	785808	1	KEY ASSEMBLY
4	045898	1	IGNITION SWITCH
5	603523	1	KNOB
6	712257	1	RED INDICATOR LIGHT
7	776476	1	PTO SWITCH
8	551451	1	INSTRUMENT PANEL (WITH DECAL)
9	601098	2	CB 10-24 X .50 ZYNC
10	601554	1	IGNITION CONTROLLER
11	059832	4	NT #10-24 HX NL ZN
12	063198	2	CS 10-24 X .75 HX FLK ZN
13	603409	1	THROTTLE CABLE
14	704932	2	FW .219 X .50 X .048 ZNYC
15	055947	4	CS .250-20 X .50 HX G5
16	768515	4	FW .281 X .625 X .051/.080H
17	603916	1	INSTRUMENT PANEL DECAL
18	000430	1	WIRE TIE
19	034280	1	CS .312-18 X .75 HX G5
20	768523	2	FW .343 X .687 X .051/.080H
21	043570	1	LOOP CLAMP
22	034272	1	NT .312-18 HX G5 ZNYC
23	603927	1	WIRE HARNESS
24	000331	6	WIRE TIE (NOT SHOWN)
25	114052	1	CLUTCH CONNECTOR REPAIR KIT

---

### **NOTES:**

1. Part of the wire harness.

# **Instrument Panel—S/N Prior to 12071770**

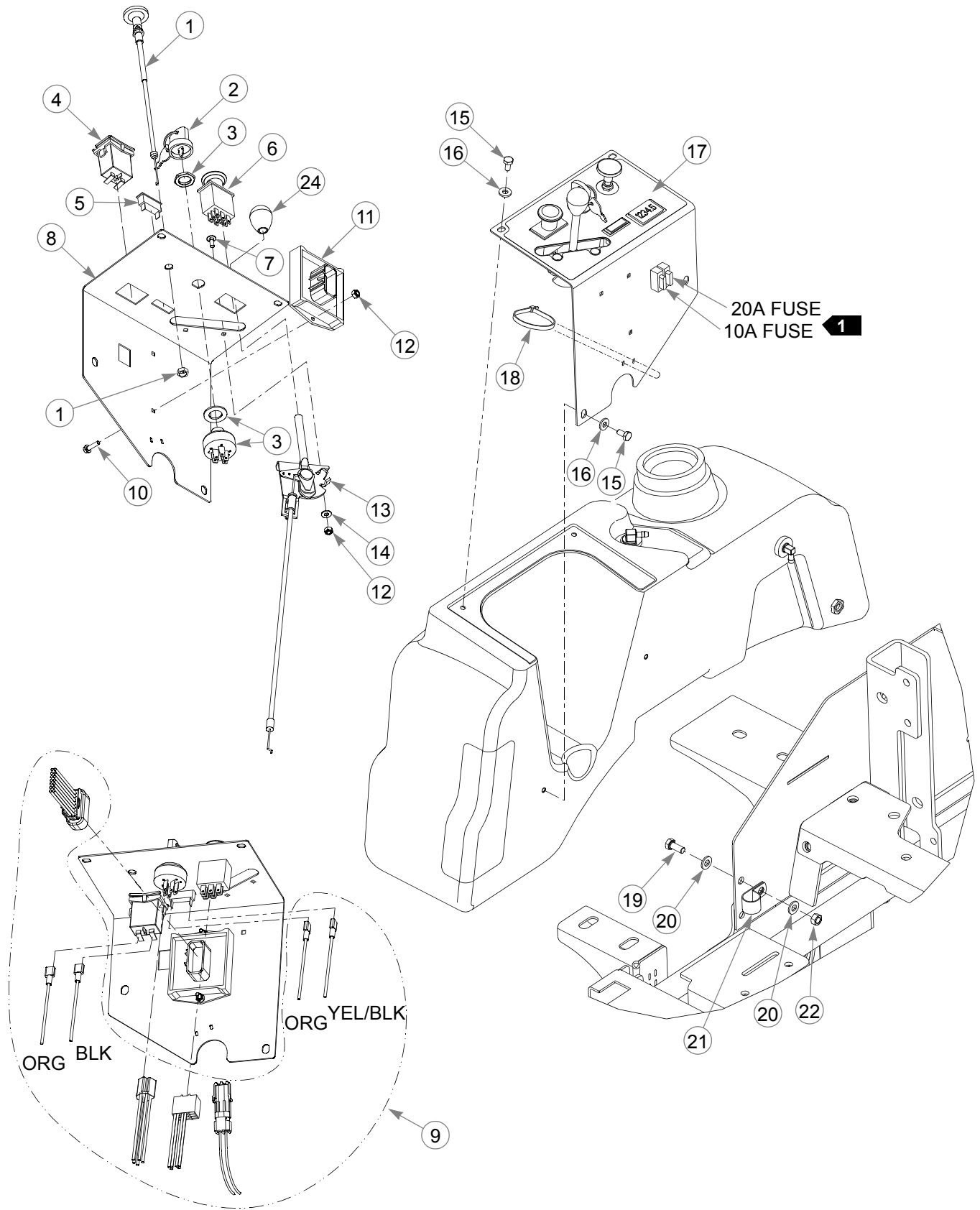

---

## **Instrument Panel–S/N Prior to 12071770**

INDEX NO.	PART NO.	QTY.	DESCRIPTION
1	603087	1	CHOKE CABLE (KAWASAKI ENGINE)
	786657	1	CHOKE CABLE (KOHLER ENGINE)
2	785808	1	KEY ASSEMBLY
3	045898	1	IGNITION SWITCH
4	603002	1	HOUR METER
5	712257	1	RED INDICATOR LIGHT
6	776476	1	PTO SWITCH
7	601098	2	CB 10-24 X .500 ZYNC
8	550856	1	INSTRUMENT PANEL (WITH DECAL)
9	603125	1	WIRE HARNESS
10	063198	2	CS 10-24 X .75 HX FLK ZN
11	604373	1	RELAY CONTROL MODULE
12	059832	4	NT #10-24 HX NL ZN
13	603409	1	THROTTLE CABLE
14	704932	2	FW .219 X .500 X .048 ZNYC
15	055947	4	CS .250-20 X .500 HX G5
16	768515	4	FW .281 X .625 X .051/.080 HD ZN/YL
17	603056	1	INSTRUMENT PANEL DECAL
18	000430	1	WIRE TIE
19	034280	1	CS .312-18 X .75 HX G5
20	768523	2	FW .343 X .687 X .051/.080H
21	043570	1	LOOP CLAMP
22	034272	1	NT .312-18 HX G5 ZNYC
23	000331	4	WIRE TIE
24	603523	1	KNOB
25	114052	1	CLUTCH CONNECTOR REPAIR KIT

---

### **NOTES:**

1. Part of the wire harness.



---

## Section 7

60" Side Discharge Service Deck . . . . .	7-2
60" Side Discharge Deck Pulleys & Spindles . . . . .	7-4
60" Side Discharge Deck . . . . .	7-6
66" Side Discharge Service Deck . . . . .	7-8
66" Side Discharge Deck Pulleys & Spindles . . . . .	7-10
66" Side Discharge Deck . . . . .	7-12
72" Side Discharge Service Deck . . . . .	7-14
72" Side Discharge Deck Pulleys & Spindles . . . . .	7-16
72" Side Discharge Deck . . . . .	7-18
Side Discharge Deck Lift . . . . .	7-20
Side Discharge Deck Mounting Hardware . . . . .	7-22
60" Rear Discharge Service Deck . . . . .	7-24
60" Rear Discharge Deck Pulleys & Spindles . . . . .	7-26
60" Rear Discharge Dust Shield . . . . .	7-30
60" Rear Discharge Deck . . . . .	7-32
72" Rear Discharge Service Deck . . . . .	7-36
72" Rear Discharge Deck Pulleys & Spindles . . . . .	7-38
72" Rear Discharge Dust Shield . . . . .	7-42
72" Rear Discharge Deck . . . . .	7-44
Rear Discharge Deck Lift . . . . .	7-48
Rear Discharge Deck Mounting Hardware . . . . .	7-50

# **60" Side Discharge Service Deck**

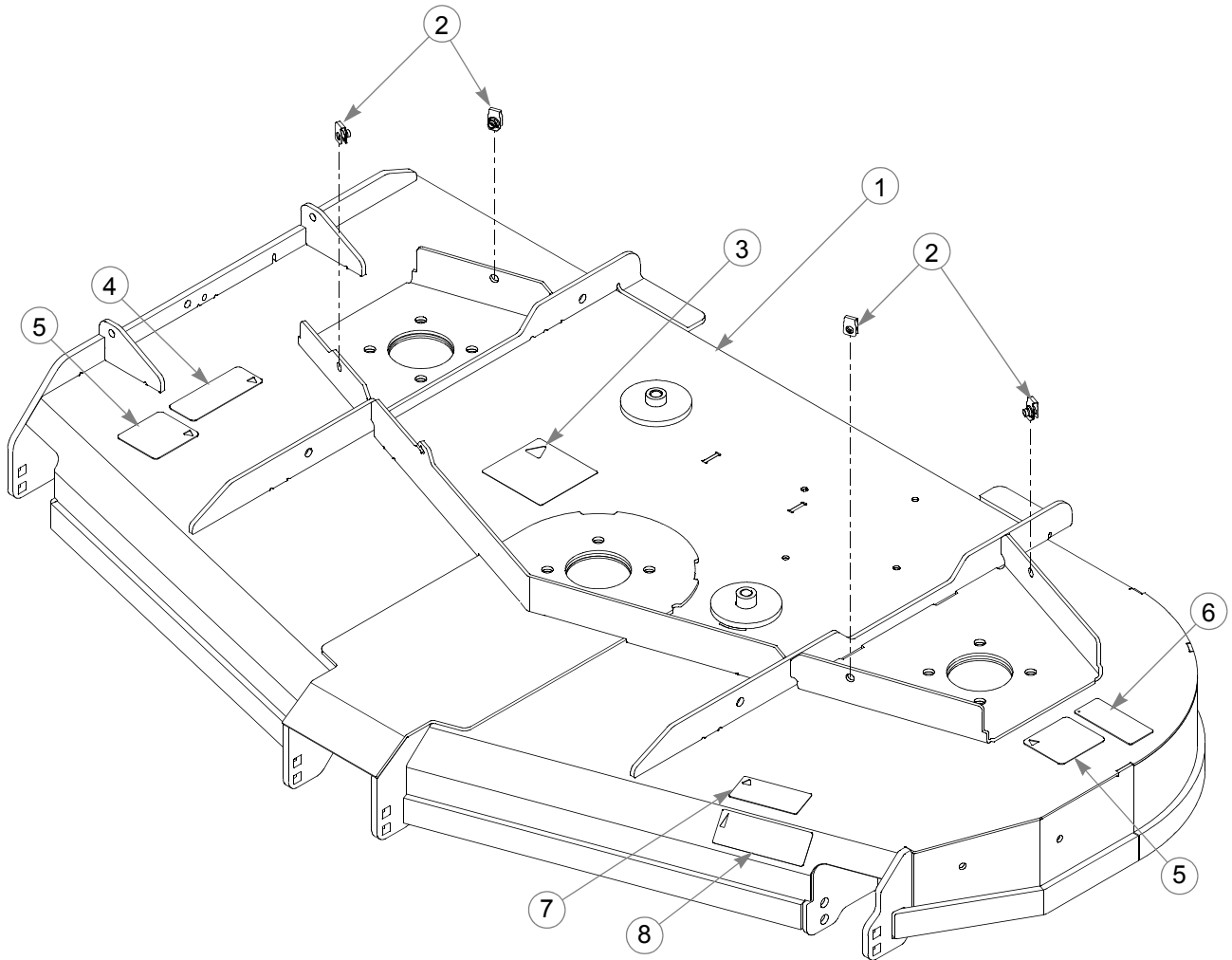



---

## **60" Side Discharge Service Deck**

INDEX NO.	PART NO.	QTY.	DESCRIPTION
1	550739	1	60" VX4 DECK (WITH DECALS & HARDWARE)
2	601069	4	CN .312-18 X .20 MAX THK
3	781419	1	BELT ROUTING DECAL
4	601624	1	DISCHARGE CHUTE DECAL
5	601837	2	DECK DANGERS DECAL
6	601892	1	THROWN OBJECTS DECAL
7	786277	1	60" DECK DECAL
8	603092	1	VX4 TECHNOLOGY DECAL

---

### **NOTES:**

# 60" Side Discharge Deck Pulleys & Spindles

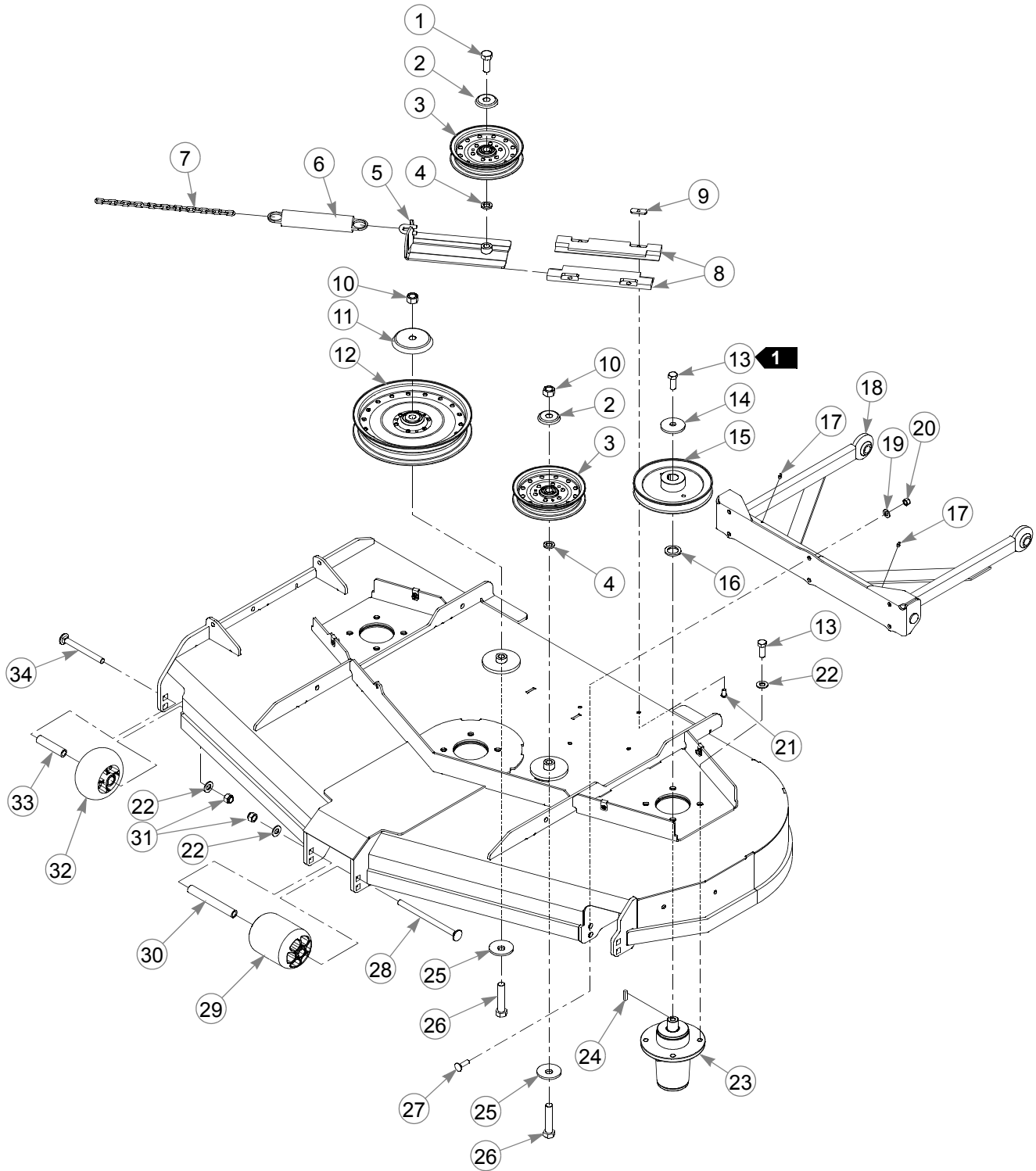

---

## **60" Side Discharge Deck Pulleys & Spindles**

INDEX NO.	PART NO.	QTY.	DESCRIPTION
1	794446	1	CS .625-11 X 1.50 HX G5
2	602935	2	IDLER DUST SHIELD SM
3	602821	2	IDLER 6.0" RIVETED
4	028118	2	FW .625 X 1.00 X .134 ZNYC
5	350884	1	DECK IDLER SLIDE
6	781302	1	TENSION SPRING
7	373191	1	CHAIN
8	602936	2	UHMW IDLER SLIDE
9	603023	4	WN .312-18 ZN
10	016972	2	NT .625-11 HX G5 ZNYC
11	602963	1	IDLER DUST SHIELD LG
12	602743	1	IDLER 10.0" RIVETED
13	705954	15	CS .500-13 X 1.25 HX G5 ZN
14	752386	3	CW .515 X 2.25 X .204 BLK
15	602745	3	PULLEY DRIVE 7.00 EFF
16	045765	3	FW 1.030 X 1.50 X .134 ZN
17	015495	2	GREASE FITTING STRAIGHT
18	113340	1	PUSHER
19	767954	6	FW .406 X .812 X .060 SAE
20	086660	6	NT .375-16 HX ZY NL
21	603022	4	CS .312-18 X .625 BH ZN
22	767962	15	FW .531 X 1.063 X .090 SAE
23	604255	3	BLADE SPINDLE CW
24	212472	3	KEY 1/4 SQ X 1.00
25	782474	2	CW .631 X 2.25 X .187 PNT
26	783738	2	CS .625-11 X 3.00 FULL HX G5
27	603113	6	CB .375-16 X 1.25 G5 ZN
28	602338	1	CB .500-13 X 7.50 STD ZN
29	602341	1	PLASTIC WHEEL
30	602344	1	SPACER 5.73
31	781567	3	NT .500-13 HX G8 ZY NL
32	602263	2	PLASTIC WHEEL
33	602345	2	SPACER 3.22
34	603049	2	CB .500-13 X 5.00 ZNYC

---

### **NOTES:**

1. Torque to 67–75 ft-lbs.

# 60" Side Discharge Deck

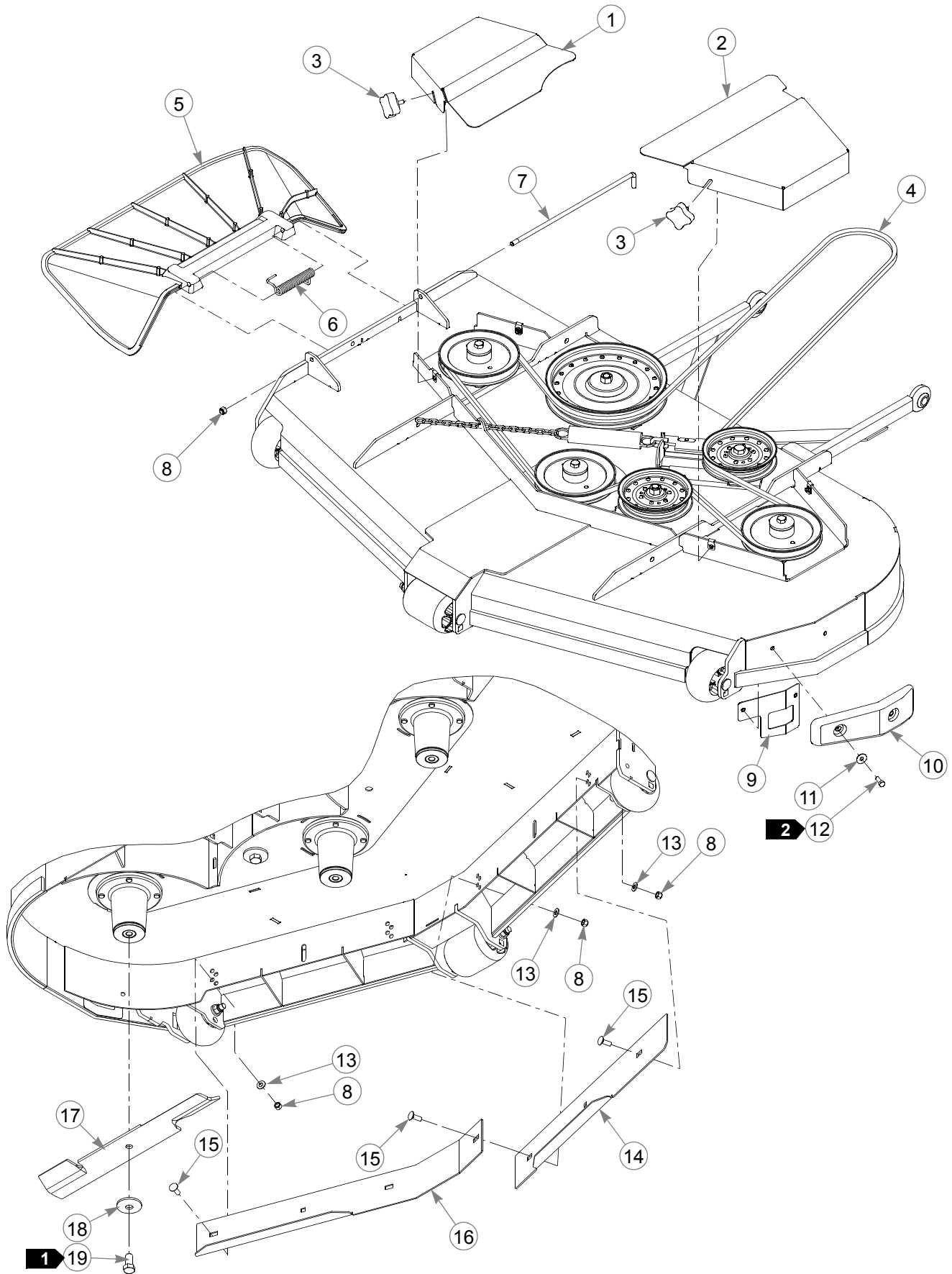

---

## **60" Side Discharge Deck**

INDEX NO.	PART NO.	QTY.	DESCRIPTION
1	112933	1	RS PULLEY COVER
2	112934	1	LS PULLEY COVER
3	792002	4	KNOB 5/16-18 X 3/4"
4	602744	1	BELT, B-SEC
5	602891	1	DISCHARGE CHUTE LG
6	602435	1	TORSION SPRING
7	602432	1	CHUTE PIN
8	086660	7	NT .375-16 HX ZY NL
9	113563	1	BACKING PLATE
10	602817	1	RUBBER BUMPER
11	079210	2	FW .344 X 1.00 X .06 ZNYC
12	064014	2	CS .312-18 X .875 HX G5 ZN
13	767954	6	FW .406 X .812 X .060 SAE
14	113180	1	RS INNER WALL ADJ.
15	025395	6	CB .375-16 X 1.00 G5 ZNY
16	113179	1	LS INNER WALL ADJ.
17	602771	3	BLADE, F20.50" EHN-F-CW
	793794	3	BLADE, 20.50" -L-F-CW
	794214	3	BLADE, 20.50" -MUL-F-CW
	794230	3	BLADE, 20.50" GAT-F-CW
	794685	3	BLADE, F20.50" -H-F-CW
18	782474	3	CW .631 X 2.25 X .187 PNT
19	781872	3	CS .625-11 X 1.25 HX G5 Z (S/N 12092683 & HIGHER)
	601983	3	CS .625-11 X 2.25 HX G5 ZY (S/N PRIOR TO 12092683)

---

### **NOTES:**

1. Torque to 118 ft-lbs.
2. Torque to 10 ft-lbs.

# **66" Side Discharge Service Deck**

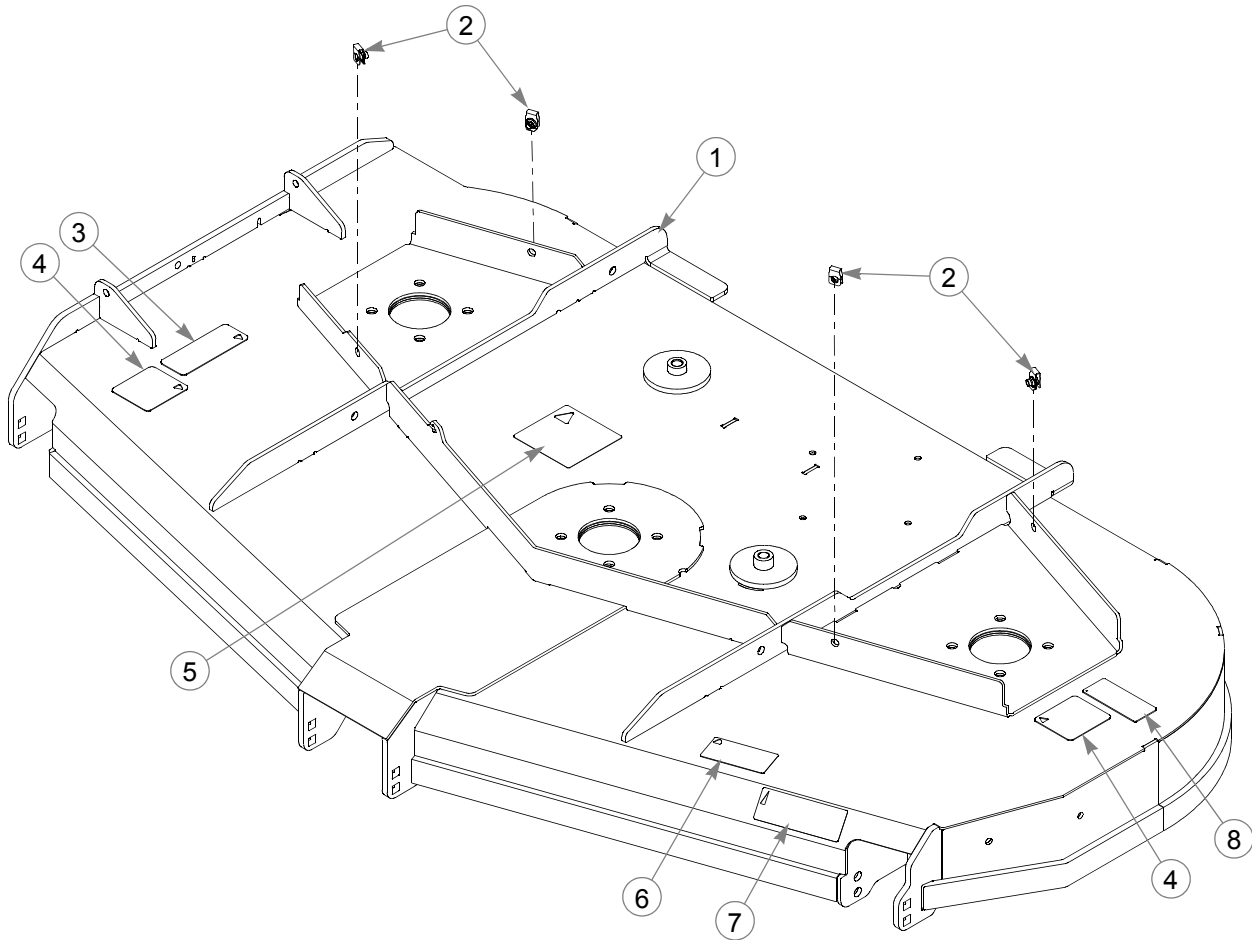

---

## **66" Side Discharge Service Deck**

INDEX NO.	PART NO.	QTY.	DESCRIPTION
1	550750	1	66" VX4 DECK (WITH DECALS & HARDWARE)
2	601069	4	CN .312-18 X .20 MAX THK
3	601624	1	DISCHARGE CHUTE DECAL
4	601837	2	DECK DANGERS DECAL
5	781419	1	BELT ROUTING DECAL
6	799189	1	66" DECK ID DECAL
7	603092	1	VX4 TECHNOLOGY DECAL
8	601892	1	THROWN OBJECTS DECAL

---

### **NOTES:**

# 66" Side Discharge Deck Pulleys & Spindles

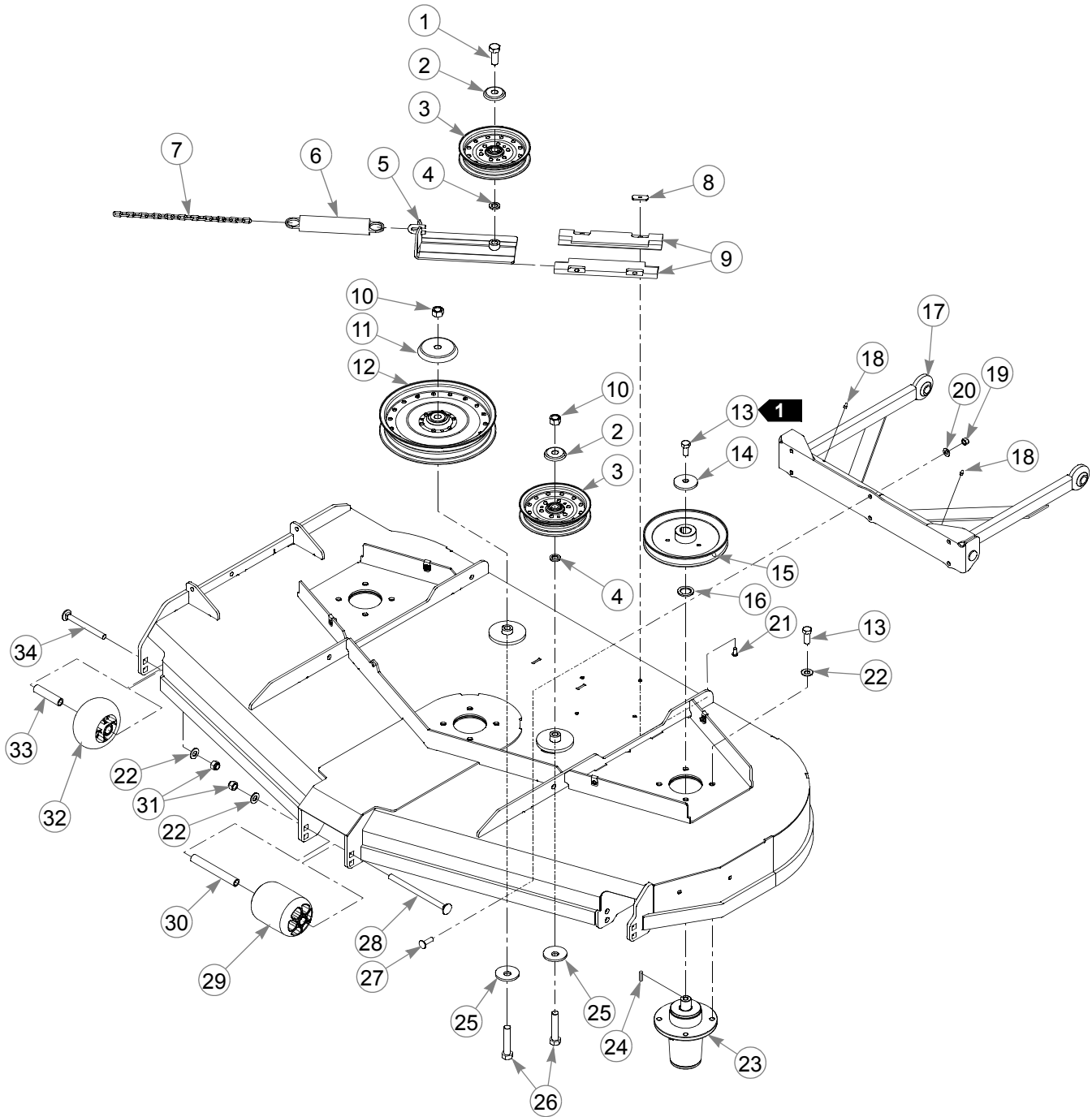



---

## **66" Side Discharge Deck Pulleys & Spindles**

INDEX NO.	PART NO.	QTY.	DESCRIPTION
1	794446	1	CS .625-11 X 1.50 HX G5
2	602935	2	IDLER DUST SHIELD SM
3	602821	2	IDLER 6.0" RIVETED
4	028118	2	FW .625 X 1.00 X .134 ZNYC
5	350884	1	DECK IDLER SLIDE
6	781302	1	TENSION SPRING
7	373191	1	CHAIN 21 LINK
8	603023	4	WN .312-18 ZN
9	602936	2	UHMW IDLER SLIDE
10	016972	2	NT .625-11 HX G5 ZNYC
11	602963	1	IDLER DUST SHIELD LG
12	602743	1	IDLER 10.0" RIVETED
13	705954	15	CS .500-13 X 1.25 HS G5
14	752386	3	CW .515 X 2.25 X .204 BLK
15	602859	3	DRIVE PULLEY 7.85 EFF
16	045765	3	FW 1.030 X 1.50 X .134
17	113340	1	PUSHER
18	015495	2	GREASE FITTING STRAIGHT
19	086660	6	NT .375-16 NL G5
20	767954	6	FW .406 X .812 X .060 SAE
21	603022	4	CS .312-18 X .625 BH ZN
22	767962	15	FW .531 X 1.063 X .090 SAE
23	604255	3	BLADE SPINDLE CW (S/N 12092683 & HIGHER)
	601630	3	BLADE SPINDLE CW (S/N PRIOR TO 12092683)
24	212472	3	KEY 1/4 SQ X 1.00
25	782474	2	CW .631 X 2.25 X .187 PNT
26	783738	2	CS .625-11 X 3.00 FULL HX G5
27	603113	6	CB .375-16 X 1.25 G5 ZN
28	602338	1	CB .500-13 X 7.50 STD ZN
29	602341	1	PLASTIC WHEEL
30	602344	1	SPACER 5.73
31	781567	3	NT .500-13 NL G5
32	602263	2	PLASTIC WHEEL
33	602345	2	SPACER 3.22
34	603049	2	CB .500-13 X 5.00 ZNYC

---

### **NOTES:**

1. Torque to 67–75 ft-lbs.

# 66" Side Discharge Deck

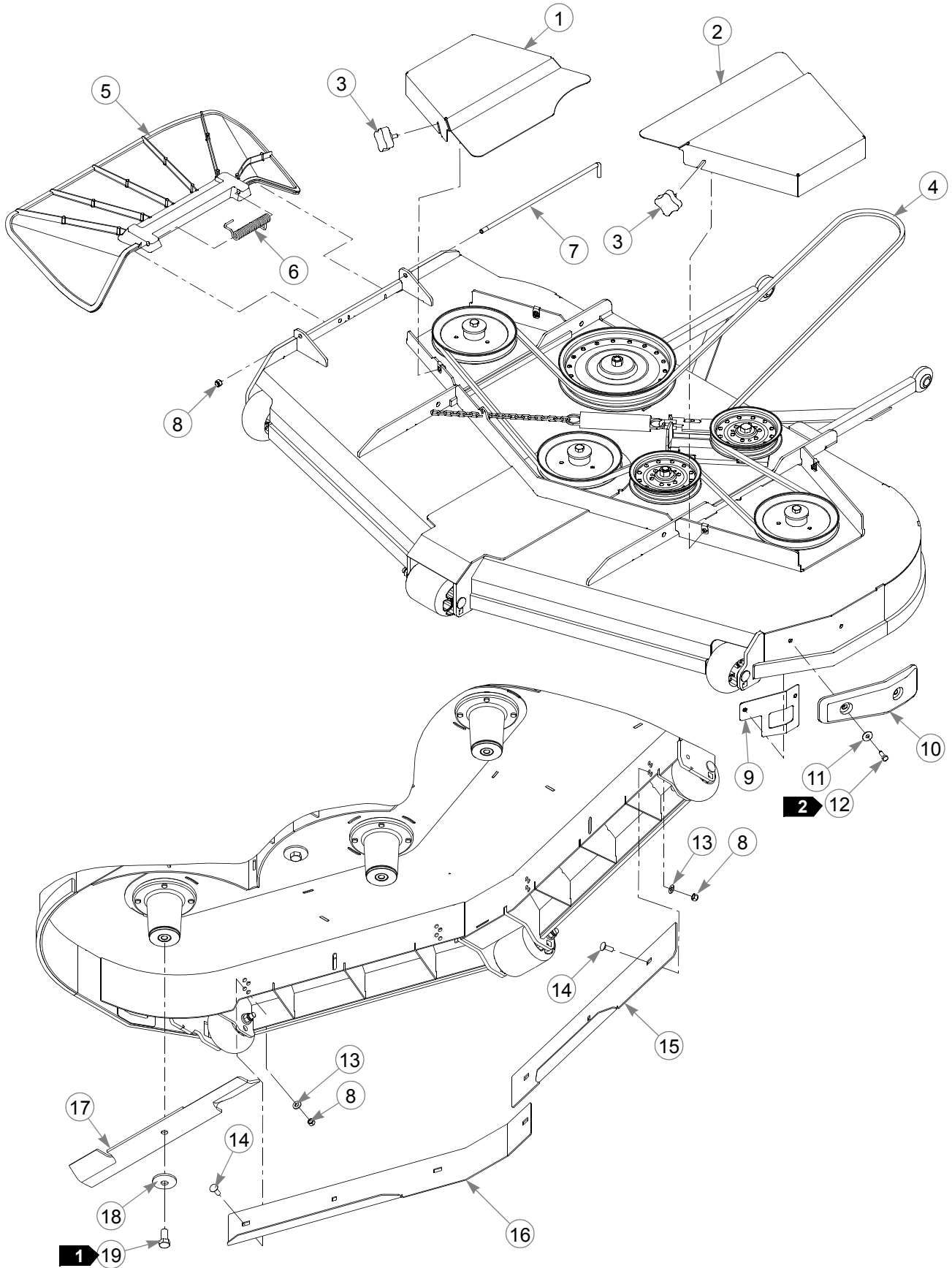

---

## **66" Side Discharge Deck**

INDEX NO.	PART NO.	QTY.	DESCRIPTION
1	113335	1	RS PULLEY COVER
2	113336	1	LS PULLEY COVER
3	792002	4	KNOB 5/16-18 X 3/4"
4	602860	1	B-SEC BELT
5	602891	1	DISCHARGE CHUTE LG
6	602435	1	TORSION SPRING
7	602432	1	CHUTE PIN
8	086660	7	NT .375-16 NL G5
9	113563	1	BACKING PLATE
10	602817	1	RUBBER BUMPER
11	079210	2	FW .344 X 1.00 X .06 ZNYC
12	064014	2	CS .312-18 X .875 HX G5 ZN
13	767954	6	FW .406 X .812 X .060 SAE
14	025395	6	CB .375-16 X 1.00 G5 ZNY
15	113333	1	RS INNER WALL ADJ.
16	113334	1	LS INNER WALL ADJ.
17	602864	3	BLADE, F22.50" EHN-F-CW
	798496	3	BLADE, F22.50" -H-F-CW
	798512	3	BLADE, 22.50" -GAT-F-CW
	798504	3	BLADE, 22.50" -MUL-F-CW
18	782474	3	CW .631 X 2.25 X .187 PNT
19	781872	3	CS .625-11 X 1.25 HX G5 Z (S/N 12092683 & HIGHER)
	601983	3	CS .625-11 X 2.25 HX G5 ZY (S/N PRIOR TO 12092683)

---

### **NOTES:**

1. Torque to 118 ft-lbs.
2. Torque to 10 ft-lbs.

# **72" Side Discharge Service Deck**

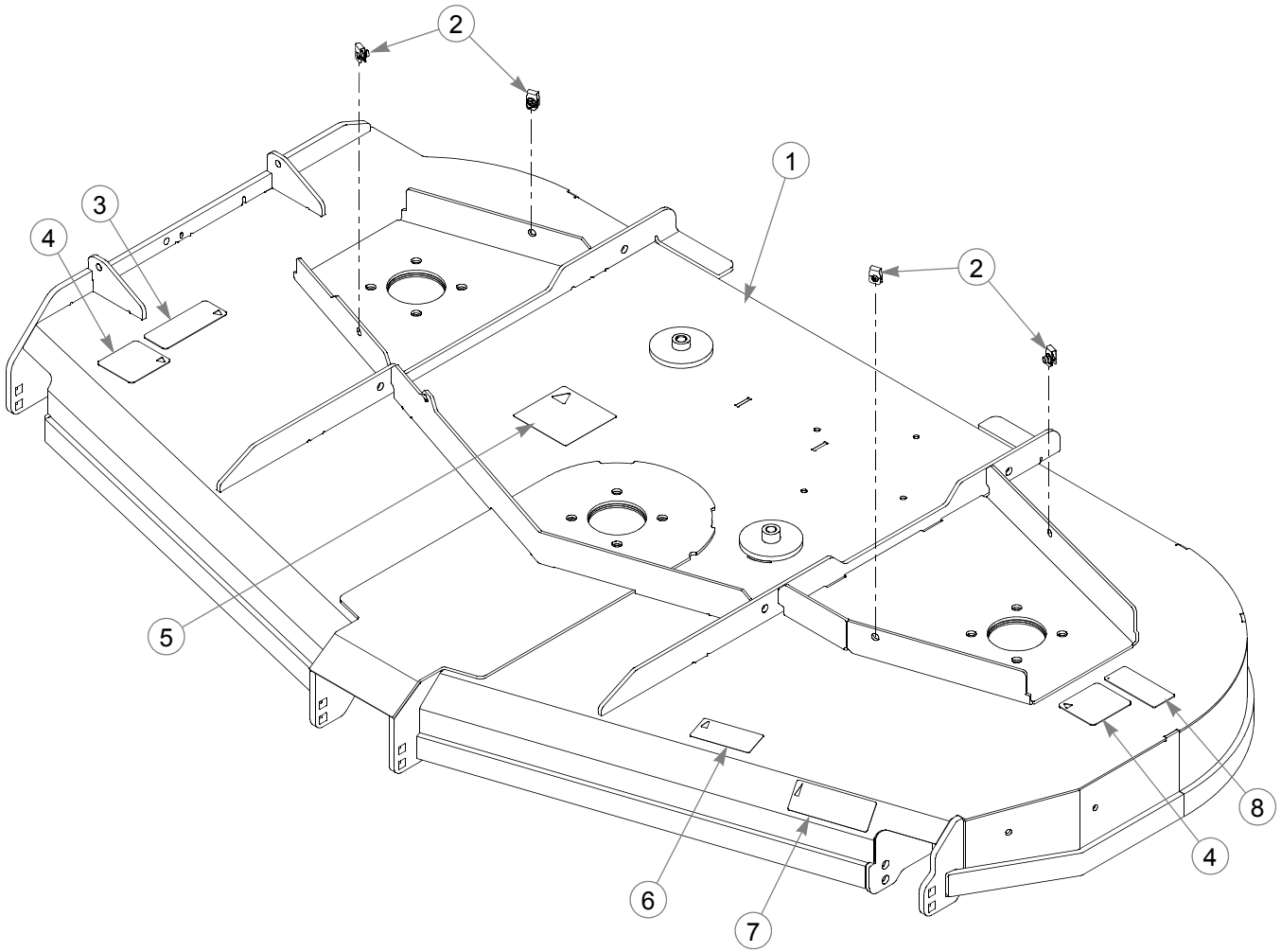

---

## **72" Side Discharge Service Deck**

INDEX NO.	PART NO.	QTY.	DESCRIPTION
1	550751	1	72" VX4 DECK (WITH DECALS & HARDWARE)
2	601069	4	CN .312-18 X .20 MAX THK
3	601624	1	DISCHARGE CHUTE DECAL
4	601837	2	DECK DANGERS DECAL
5	781419	1	BELT ROUTING DECAL
6	786285	1	72" DECK ID DECAL
7	603092	1	VX4 TECHNOLOGY DECAL
8	601892	1	THROWN OBJECTS DECAL

---

### **NOTES:**

# 72" Side Discharge Deck Pulleys & Spindles

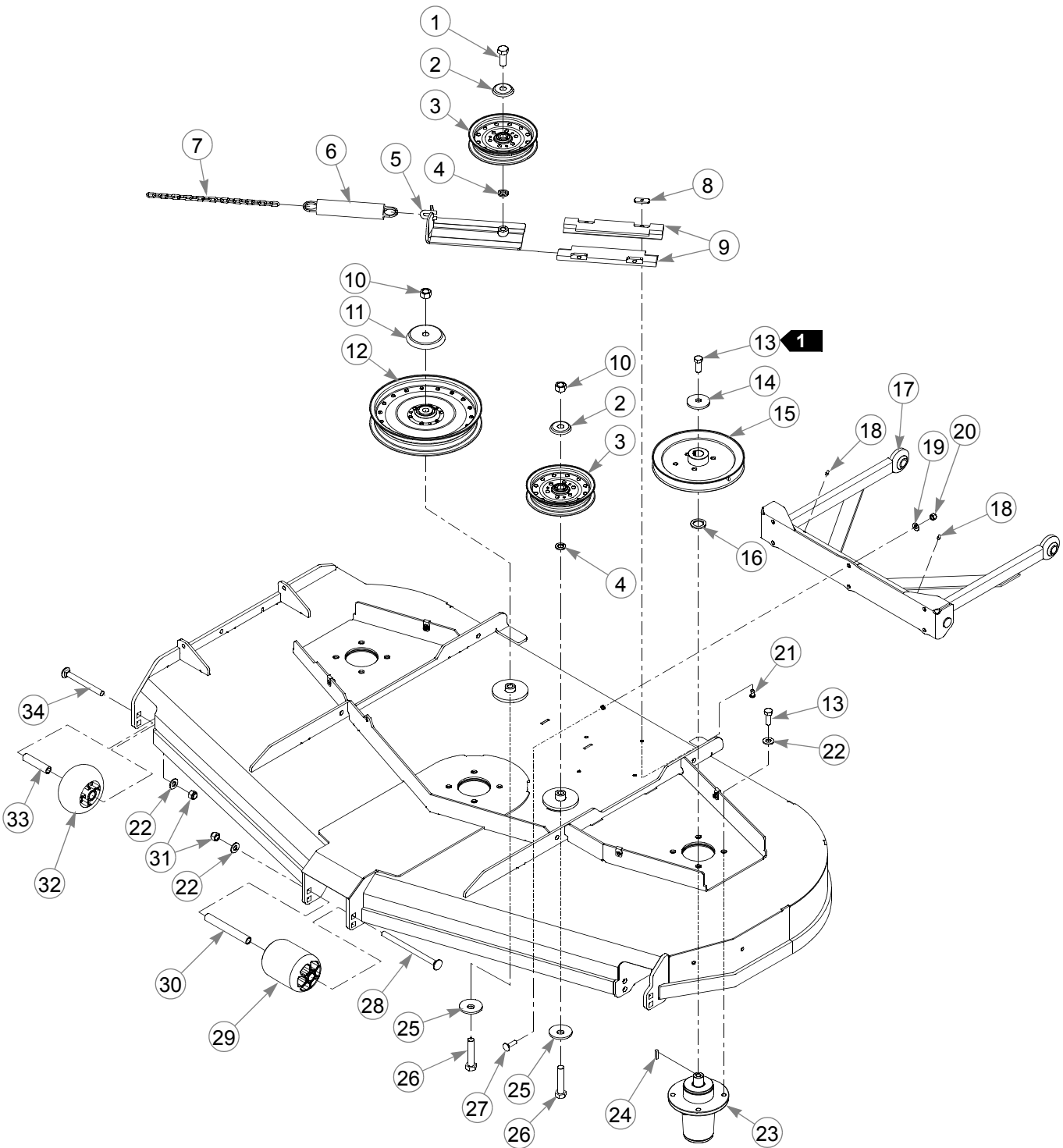

---

## **72" Side Discharge Deck Pulleys & Spindles**

INDEX NO.	PART NO.	QTY.	DESCRIPTION
1	794446	1	CS .625-11 X 1.50 HX G5
2	602935	2	IDLER DUST SHIELD SM
3	602821	2	IDLER 6.0" RIVETED
4	028118	2	FW .625 X 1.00 X .134 ZNYC
5	350884	1	DECK IDLER SLIDE
6	781302	1	TENSION SPRING
7	373191	1	CHAIN 21 LINK
8	603023	4	WN .312-18 ZN
9	602936	2	UHMW IDLER SLIDE
10	016972	2	NT .625-11 HX G5 ZNYC
11	602963	1	IDLER DUST SHIELD LG
12	602743	1	IDLER 10.0" RIVETED
13	705954	15	CS .500-13 X 1.25 HS G5
14	752386	3	CW .515 X 2.25 X .204 BLK
15	602746	3	DRIVE PULLEY 8.652 OP
16	045765	3	FW 1.030 X 1.50 X .134
17	113340	1	PUSHER
18	015495	2	GREASE FITTING STRAIGHT
19	767954	6	FW .406 X .812 X .060 SAE
20	086660	6	NT .375-16 NL G5
21	603022	4	CS .312-18 X .625 BH ZN
22	767962	15	FW .531 X 1.063 X .090 SAE
23	604255	3	BLADE SPINDLE CW (S/N 12092683 & HIGHER)
	601630	3	BLADE SPINDLE CW (S/N PRIOR TO 12092683)
24	212472	3	KEY 1/4 SQ X 1.00
25	782474	2	CW .631 X 2.25 X .187 PNT
26	783738	2	CS .625-11 X 3.00 FULL HX G5
27	603113	6	CB .375-16 X 1.25 G5 ZN
28	602338	1	CB .500-13 X 7.50 STD ZN
29	602341	1	PLASTIC WHEEL
30	602344	1	SPACER 5.73
31	781567	3	NT .500-13 HX G8 ZY NL
32	602263	2	PLASTIC WHEEL
33	602345	2	SPACER 3.22
34	603049	2	CB .500-13 X 5.00 ZNYC

---

### **NOTES:**

1. Torque to 67–75 ft-lbs.

# **72" Side Discharge Deck**

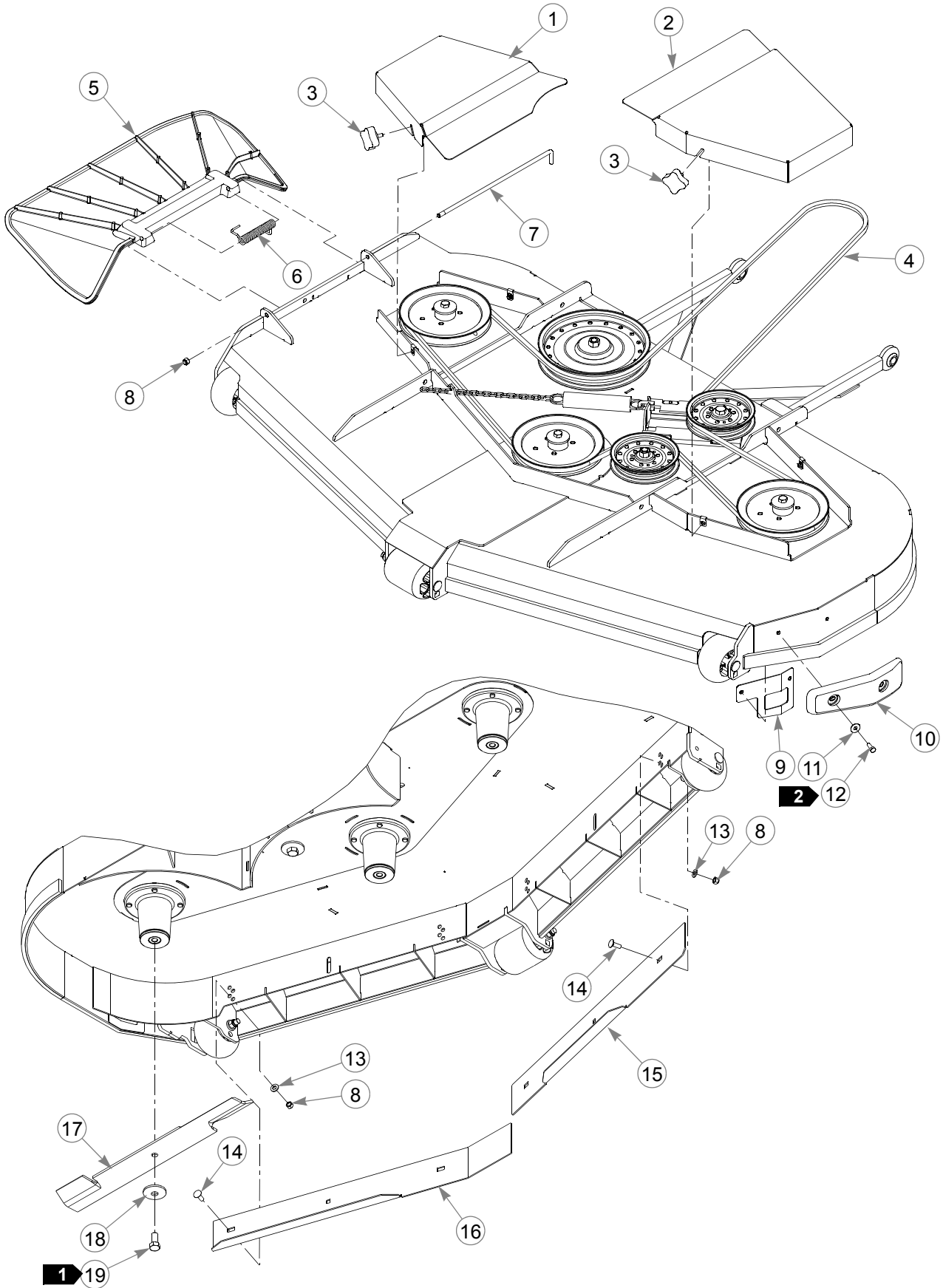



---

## **72" Side Discharge Deck**

INDEX NO.	PART NO.	QTY.	DESCRIPTION
1	112935	1	RS PULLEY COVER
2	112936	1	LS PULLEY COVER
3	792002	4	KNOB 5/16-18 X 3/4"
4	602747	1	B-SEC BELT
5	602891	1	DISCHARGE CHUTE LG
6	602435	1	TORSION SPRING
7	602432	1	CHUTE PIN
8	086660	7	NT .375-16 NL G5
9	113563	1	BACKING PLATE
10	602817	1	RUBBER BUMPER
11	079210	2	FW .344 X 1.00 X .06 ZNYC
12	064014	2	CS .312-18 X .875 HX G5 ZN
13	767954	6	FW .406 X .812 X .060 SAE
14	025395	6	CB .375-16 X 1.00 G5 ZNY
15	112931	1	RS INNER WALL ADJ.
16	112932	1	LS INNER WALL ADJ.
17	602857	3	BLADE, F24.50" EHN-F-CW
	798702	3	BLADE, F24.50"-H-F-CW
	798710	3	BLADE, 24.50"-MUL-F-CW
	798728	3	BLADE, 24.50"-GAT-F-CW
18	782474	3	CW .631 X 2.25 X .187 PNT
19	781872	3	CS .625-11 X 1.25 HX G5 Z (S/N 12092683 & HIGHER)
	601983	3	CS .625-11 X 2.25 HX G5 ZY (S/N PRIOR TO 12092683)

---

### **NOTES:**

1. Torque to 118 ft-lbs.
2. Torque to 10 ft-lbs.

# Side Discharge Deck Lift

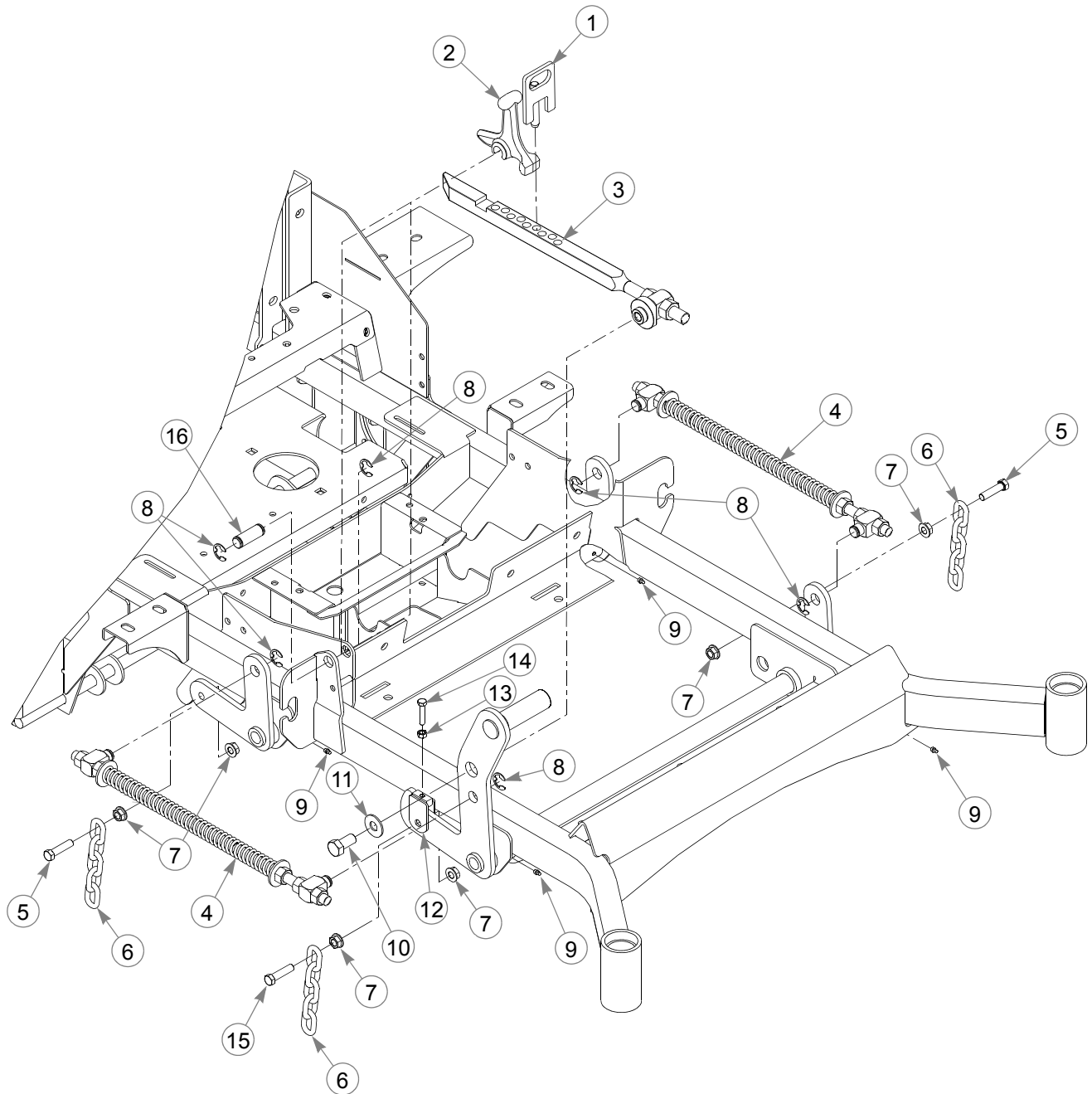

---

## **Side Discharge Deck Lift**

INDEX NO.	PART NO.	QTY.	DESCRIPTION
1	600437	1	DECK HEIGHT PIN
2	348318	1	STOP HANDLE
3	602898	1	DECK LIFT INDICATOR
4	603184	2	DECK LIFT SPRING
5	055749	7	CS .437-14 X 1.75 HX G5
6	348391	4	DECK LIFT CHAIN
7	704643	16	NT .437-14 HX FLG ZN
8	781294	6	E CLIP 1.00 X .625 X .05
9	015495	4	GREASE FITTING STRAIGHT
10	781872	1	CS .625-11 X 1.25 HX G5 Z
11	704783	1	FW .625 X 1.50 X .105 ZN
12	348458	1	DECK LEVELER YOKE
13	034272	1	NT .312-18 HX G5 ZNYC
14	756270	1	CS .312-18 X 1.50 FLTHR HX
15	781831	1	CS .437-14 X 1.75 FULTH
16	781229	1	CE .750 X 2.25 X 1.75 HEAD

---

### **NOTES:**

# Side Discharge Deck Mounting Hardware

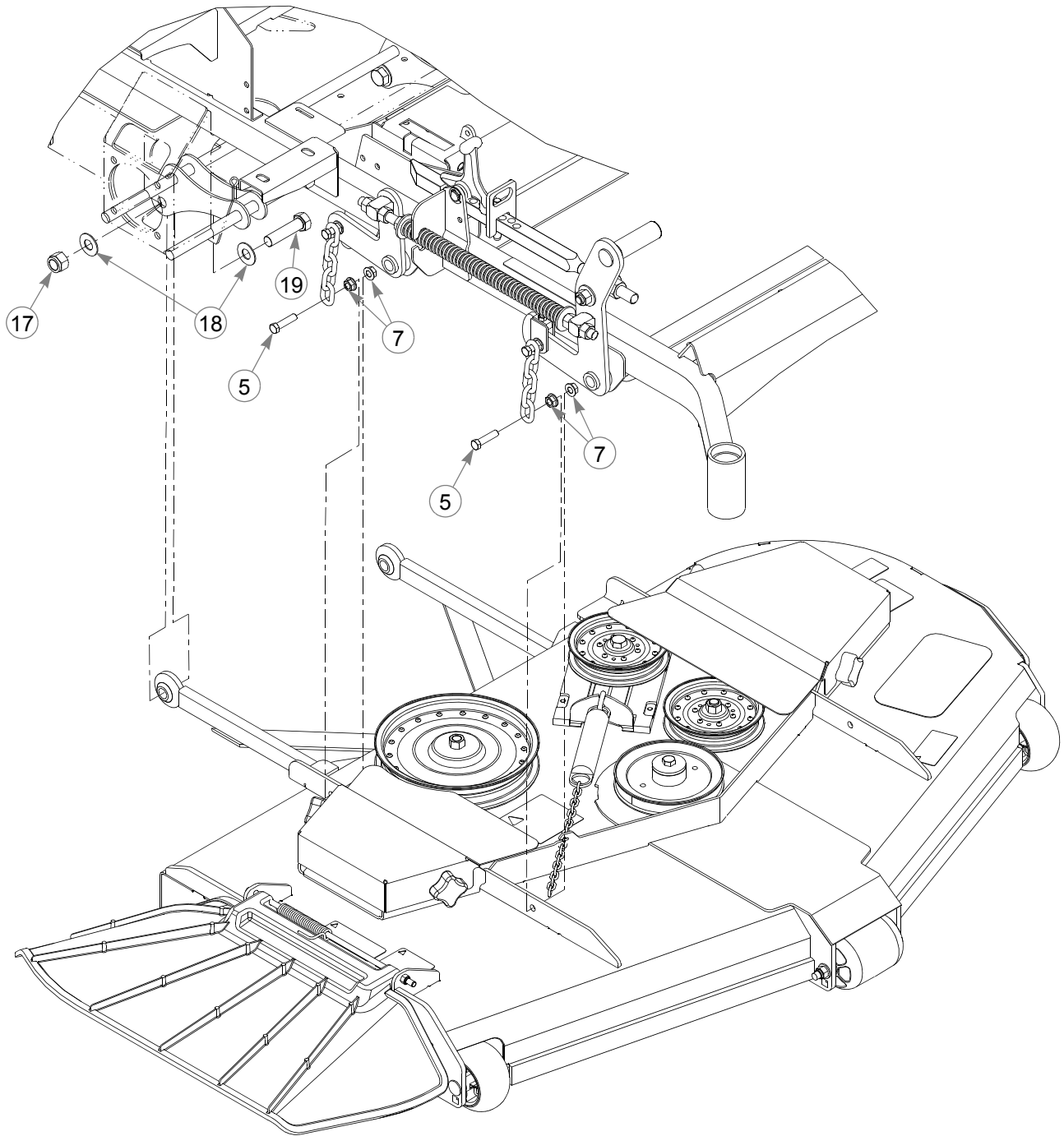

---

## **Side Discharge Deck Mounting Hardware**

INDEX NO.	PART NO.	QTY.	DESCRIPTION
17	061101	2	NT .750-10 HX ZY NL
18	025296	4	FW .760 X 1.625 X .08 ZNYC
19	051169	2	CS .750-10 X 3.00 HX G5

---

**NOTES:**

# **60" Rear Discharge Service Deck**

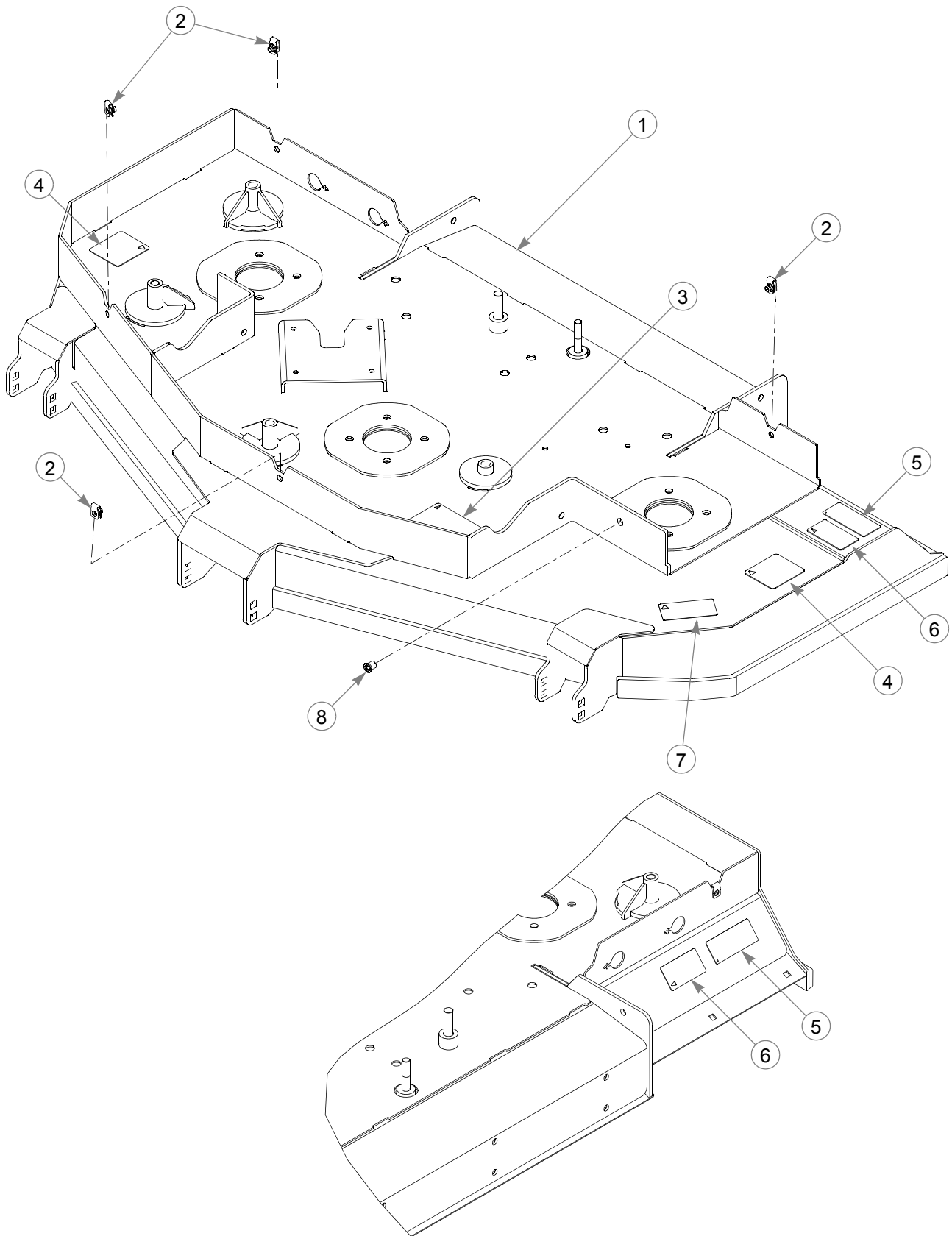

---

## **60" Rear Discharge Service Deck**

INDEX NO.	PART NO.	QTY.	DESCRIPTION
1	550935	1	60" RD DECK (WITH DECALS & HARDWARE)
2	601069	4	CN .312-18 X .20 MAX THK
3	603349	1	2 BELT ROUTING DECAL
4	601837	2	DECK DANGERS DECAL
5	601892	2	THROWN OBJECTS DECAL
6	603391	2	RUBBER FLAP DECAL
7	786277	1	60" DECK DECAL
8	792887	1	5/16-18 THREAD HEX RIVET NUT

---

### **NOTES:**

# 60" Rear Discharge Deck Pulleys & Spindles

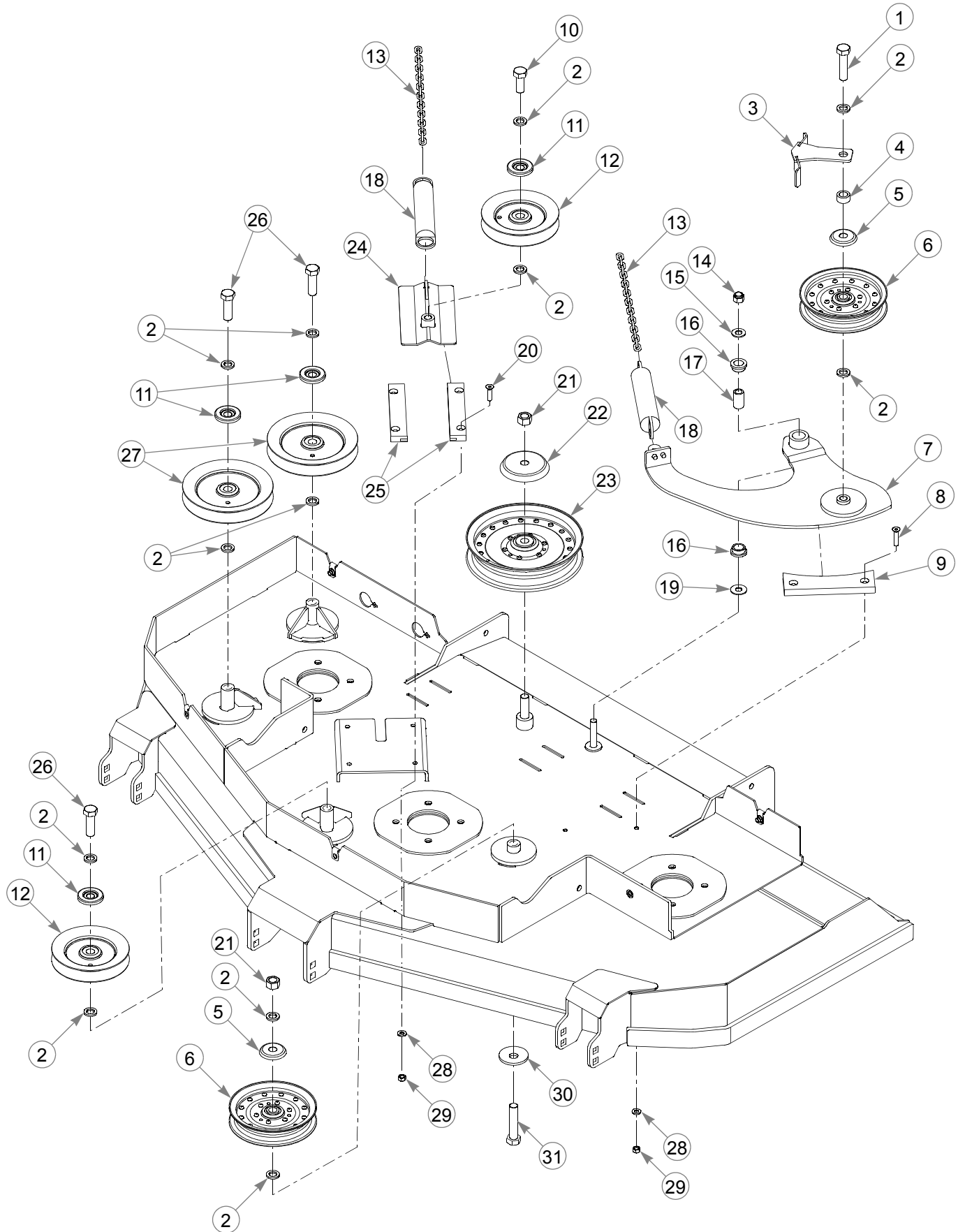



---

## **60" Rear Discharge Deck Pulleys & Spindles**

INDEX NO.	PART NO.	QTY.	DESCRIPTION
1	025015	1	CS .625-11 X 2.50 HX G5
2	028118	12	FW .625 X 1.00 X .134 ZNYC
3	113088	1	BELT GUIDE
4	603256	1	DECK IDLER SPACER 1/2" LG
5	602935	2	IDLER DUST SHIELD SM
6	602821	2	IDLER 6.0" RIVETED
7	114133	1	RD DECK IDLER ARM
8	797910	2	CS .312-18 X 1.50 FLT SH ZY
9	601779	1	IDLER GUIDE
10	794446	1	CS .625-11 X 1.50 HX G5
11	603057	4	DUST SHIELD WITH OFFSET
12	602672	2	PULLEY V-IDLER HBB 5.0"
13	373191	2	CHAIN 21 LINK
14	781567	1	NT .500-13 NL G5
15	767962	13	FW .531 X 1.063 X .090 SAE
16	770867	2	BUSHING
17	109549	1	BUSHING
18	781302	2	TENSION SPRING
19	704759	1	FW .500 X 1.25 X .075 ZNY
20	784199	4	CS .312-18 X 1.25 FLT SH
21	016972	2	NT .625-11 HX G5 ZNYC
22	602963	1	IDLER DUST SHIELD LG
23	602838	1	IDLER 8.0" RIVETED
24	114105	1	IDLER SLIDE
25	601619	2	IDLER SLIDE UHMW
26	016642	3	CS .625-11 X 2.00 HX G5 Z
27	796714	2	6" HB IDLER PULLEY
28	768523	6	FW .343 X .687 X .051/.080H
29	058776	6	NT .312-18 HX NL G5
30	782474	1	CW .631 X 2.25 X .187 PNT
31	783738	1	CS .625-11 X 3.00 FULL HX G5

---

### **NOTES:**

# **60" Rear Discharge Deck Pulleys & Spindles**

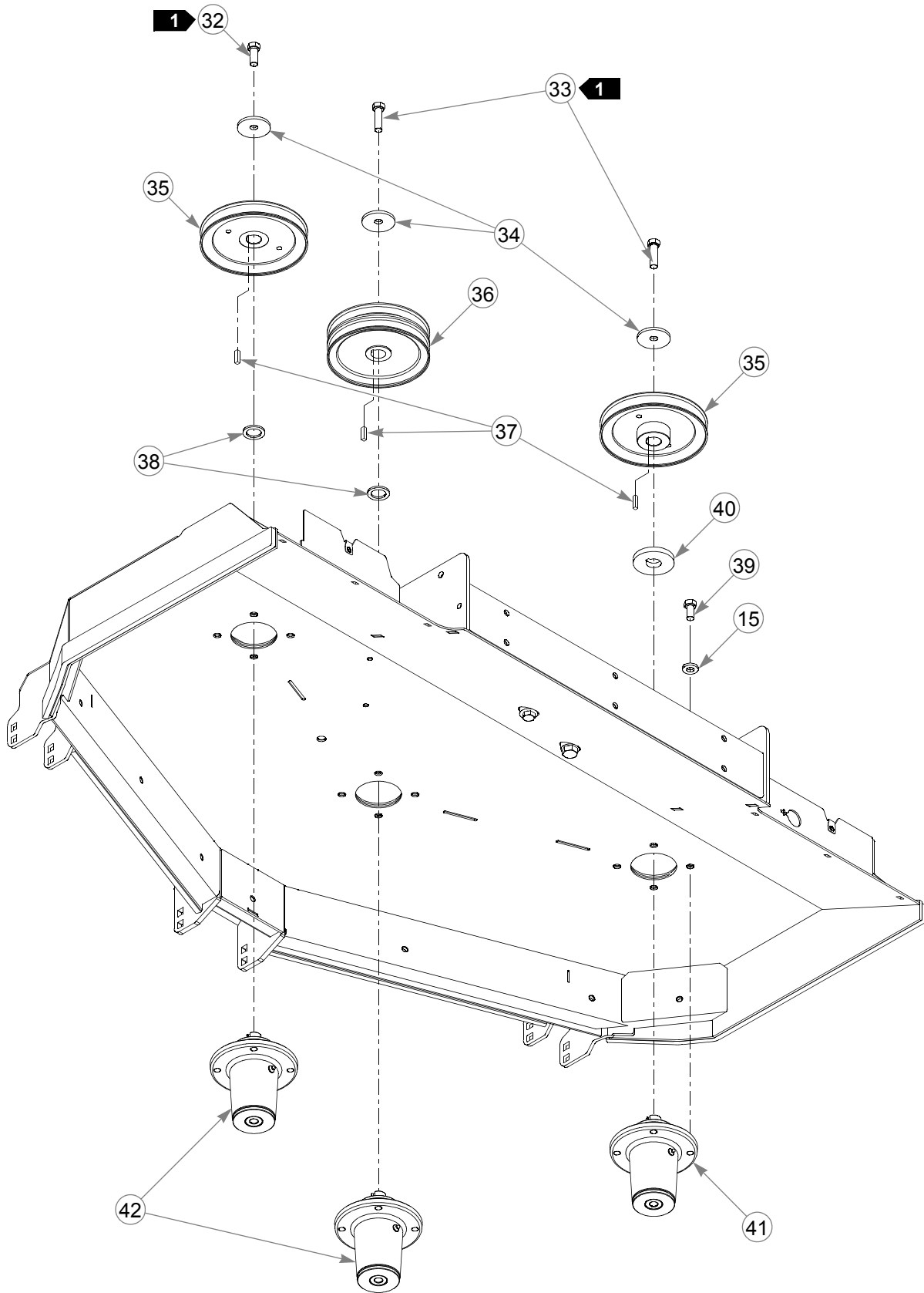

---

## **60" Rear Discharge Deck Pulleys & Spindles**

INDEX NO.	PART NO.	QTY.	DESCRIPTION
32	705954	1	CS .500-13 X 1.25 HX G5 ZN
33	017616	2	CS .500-13 X 1.75 HX G5
34	752386	3	CW .515 X 2.25 X .204 BLK
35	602745	2	PULLEY DRIVE 7.00 EFF
36	770388	1	PULLEY
37	212472	3	KEY 1/4 SQ X 1.00
38	045765	2	FW 1.030 X 1.50 X .134 ZN
39	016527	12	CS .500-13 X 1.00 HX G5 ZN
40	114108	1	SPACER
41	604256	1	BLADE SPINDLE CCW (S/N 12092683 & HIGHER)
	601819	1	BLADE SPINDLE CCW (S/N PRIOR TO 12092683)
42	604255	2	BLADE SPINDLE CW (S/N 12092683 & HIGHER)
	601630	2	BLADE SPINDLE CW (S/N PRIOR TO 12092683)

---

### **NOTES:**

1. Torque to 65–75 ft-lbs.

# **60" Rear Discharge Dust Shield**

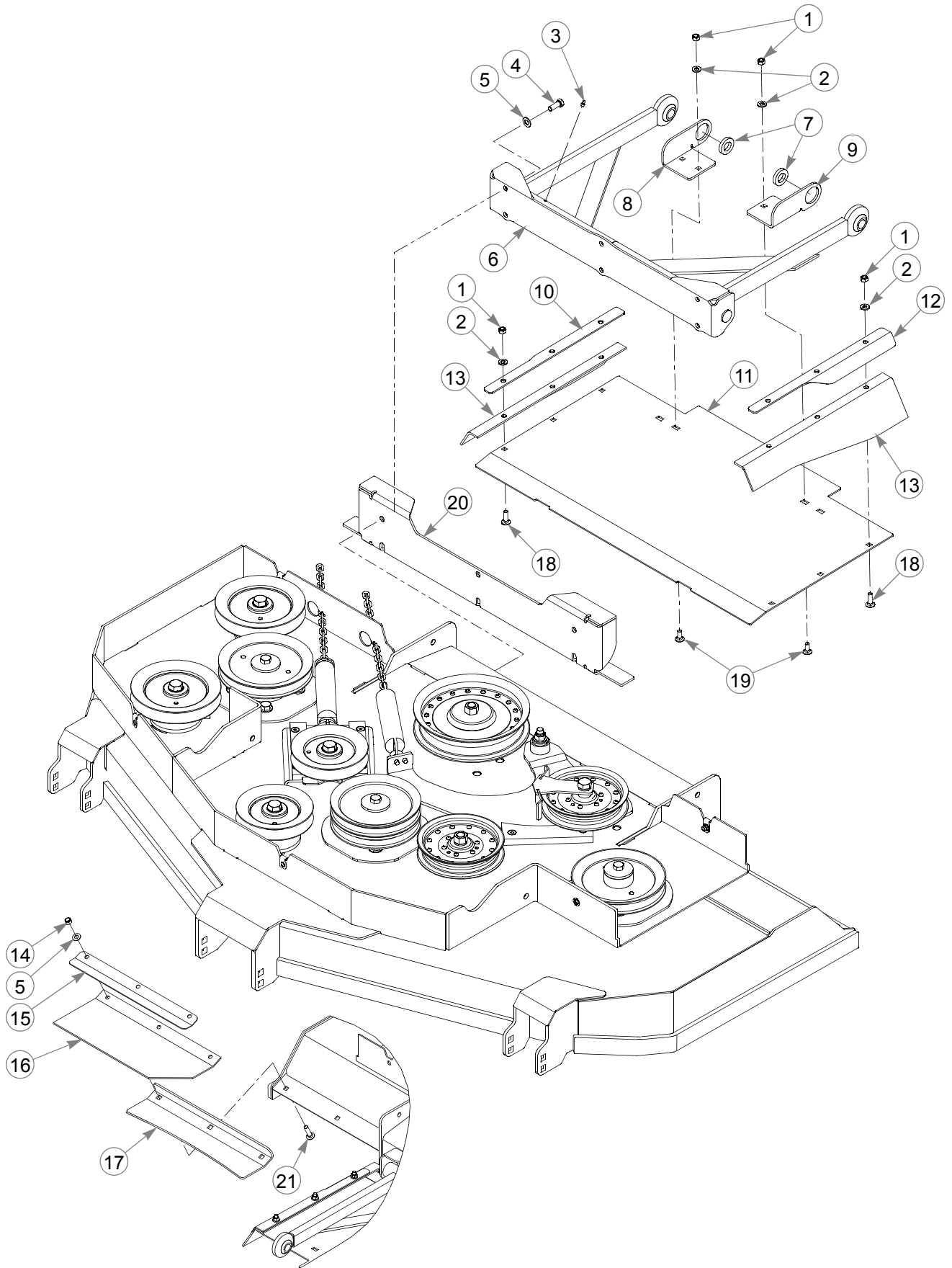

---

## **60" Rear Discharge Dust Shield**

INDEX NO.	PART NO.	QTY.	DESCRIPTION
1	058776	10	NT .312-18 HX ZY NL G5
2	768523	10	FW .343 X .687 X .051/.080H
3	015495	2	GREASE FITTING STRAIGHT
4	036244	6	CS .375-16 X 1.00 HX G5
5	767954	12	FW .406 X .812 X .060 SAE
6	113340	1	PUSHER
7	778399	2	FW .781 X 1.375 X .250 ZNY
8	109482	1	RS CHUTE BRACKET
9	109483	1	LS CHUTE BRACKET
10	109487	1	RS CLAMP ANGLE
11	114440	1	DUST SHIELD
12	109486	1	LS CLAMP ANGLE
13	601483	2	RUBBER SIDE FLAP
14	086660	6	NT .375-16 NL G5
15	106716	2	DISCHARGE CHUTE ANGLE
16	600254	2	RD REAR FLAP
17	351676	2	DECK STIFFENER ANGLE
18	037887	6	CB .312-18 X 1.00 FULL ZN
19	016253	4	CB .312-18 X .75 FUL ZN
20	114522	1	REAR DECK STOP
21	710194	6	CB .375-16 X 1.50 STD G5

---

### NOTES:

# **60" Rear Discharge Deck**

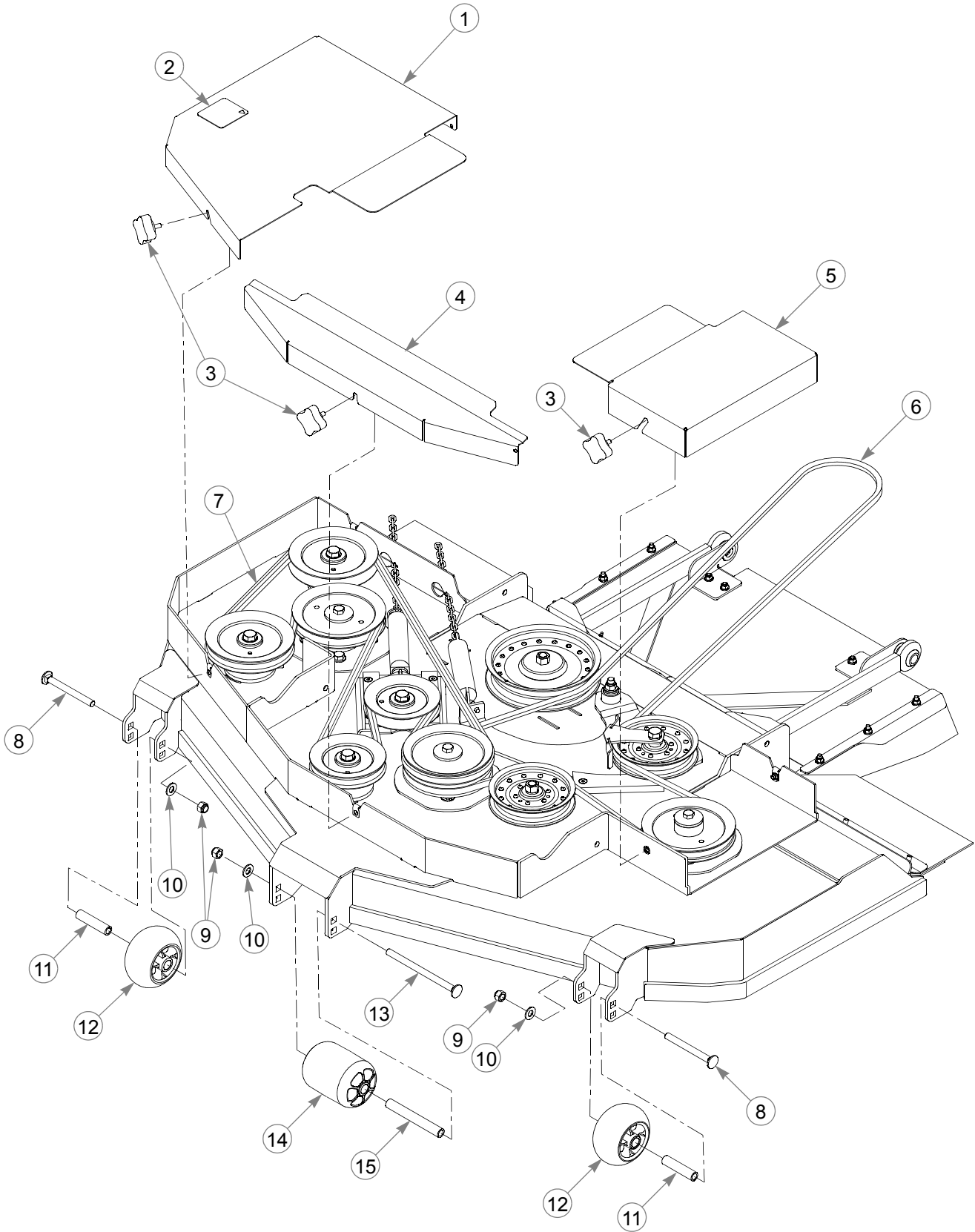

---

## **60" Rear Discharge Deck**

INDEX NO.	PART NO.	QTY.	DESCRIPTION
1	550939	1	RS PULLEY COVER (WITH DECALS)
2	601837	1	DECK DANGERS DECAL
3	792002	5	KNOB 5/16-18 X 3/4"
4	550938	1	CENTER PULLEY COVER
5	114210	1	LS PULLEY COVER
6	789388	1	BELT, B 152" EL
7	027284	1	BELT, B 138" EL
8	603049	2	CB .500-13 X 5.00 ZNYC
9	781567	3	NT .500-13 NL G5
10	767962	3	FW .531 X 1.063 X .090 SAE
11	602345	2	SPACER 3.22
12	602263	2	PLASTIC WHEEL
13	602338	1	CB .500-13 X 7.50 STD ZN
14	602341	1	PLASTIC WHEEL
15	602344	1	SPACER 5.73

---

### **NOTES:**

# 60" Rear Discharge Deck

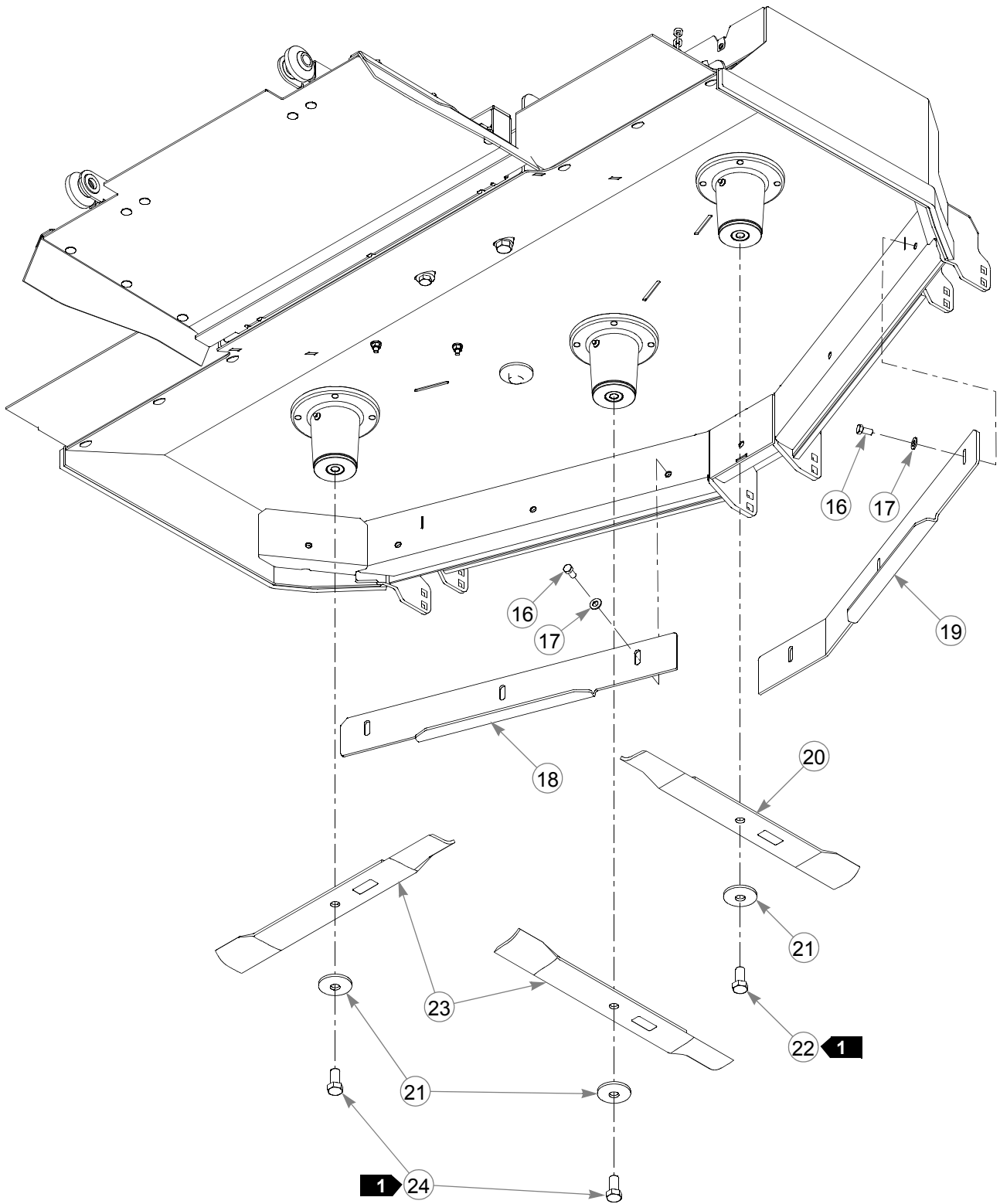



---

## **60" Rear Discharge Deck**

INDEX NO.	PART NO.	QTY.	DESCRIPTION
16	055822	6	CS .375-16 X .75 HX G5
17	767954	6	FW .406 X .812 X .060 SAE
18	114205	1	LS ADJUSTABLE BAFFLE
19	114204	1	RS ADJUSTABLE BAFFLE
20	795633	1	BLADE, F20.50" -L-F-CCW
	601928	2	BLADE, 20.50" GAT-F-CCW
21	782474	3	CW .631 X 2.25 X .187 PNT
22	604383	1	CS .625-11 X 1.25 HX G5 LH THREAD (S/N 12092683 & HIGHER)
	601999	1	CS .625-11 X 2.25 LH HX G5 H5Y (S/N PRIOR TO 12092683)
23	600901	2	BLADE, F20.50" -L-F-CW
	794230	2	BLADE, 20.50" -GAT-F-CW
24	781872	2	CS .625-11 X 1.25 HX G5 Z (S/N 12092683 & HIGHER)
	601983	2	CS .625-11 X 2.25 HX G5 ZY (S/N PRIOR TO 12092683)

---

### **NOTES:**

1. Torque to 118 ft-lbs.

# **72" Rear Discharge Service Deck**

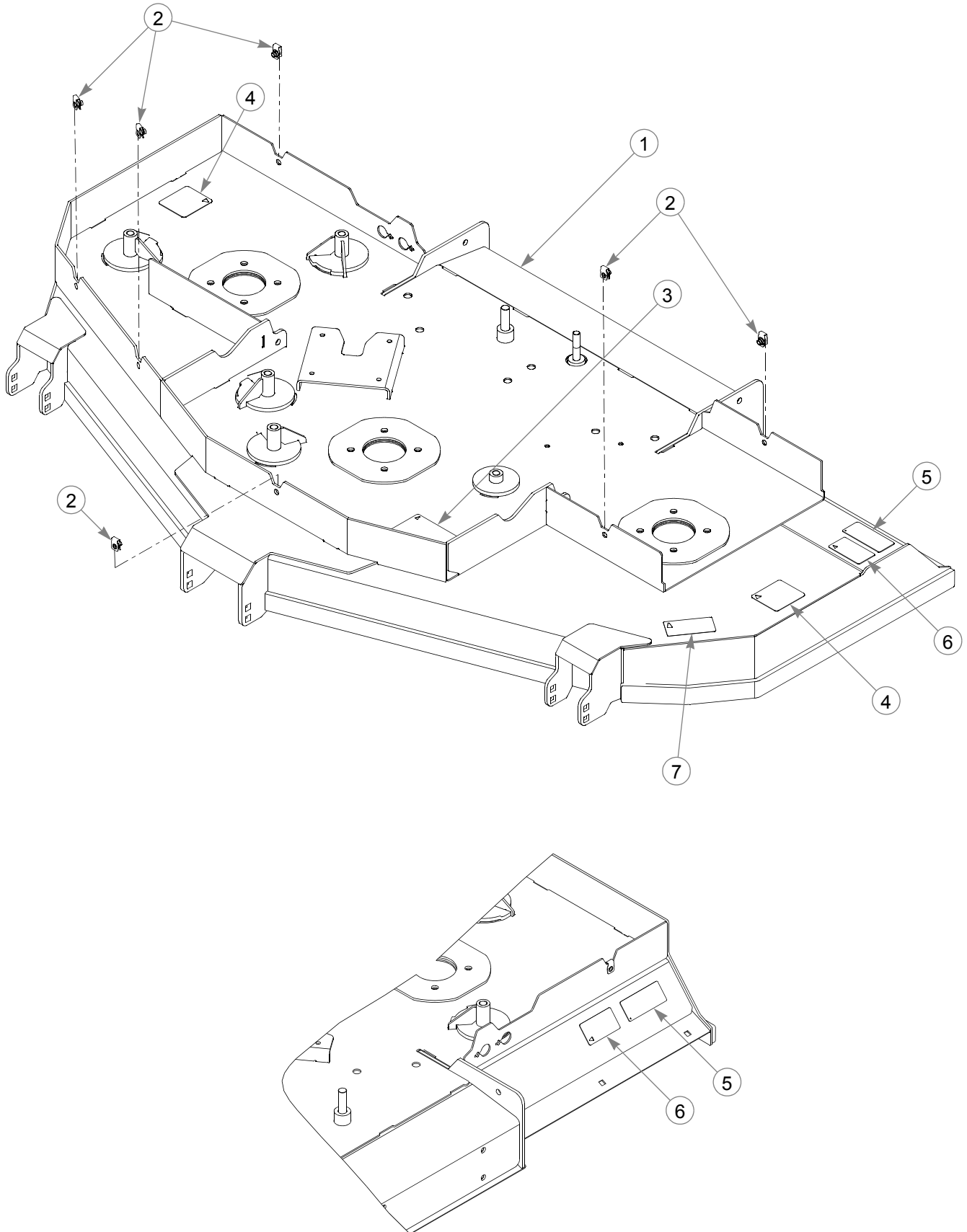

---

## **72" Rear Discharge Service Deck**

INDEX NO.	PART NO.	QTY.	DESCRIPTION
1	551049	1	72" RD DECK (WITH DECALS & HARDWARE)
2	601069	6	CN .312-18 X .20 MAX THK
3	603349	1	2 BELT ROUTING DECAL
4	601837	2	DECK DANGERS DECAL
5	601892	2	THROWN OBJECTS DECAL
6	603391	2	RUBBER FLAP DECAL
7	786285	1	72" DECK ID DECAL

---

**NOTES:**

# 72" Rear Discharge Deck Pulleys & Spindles

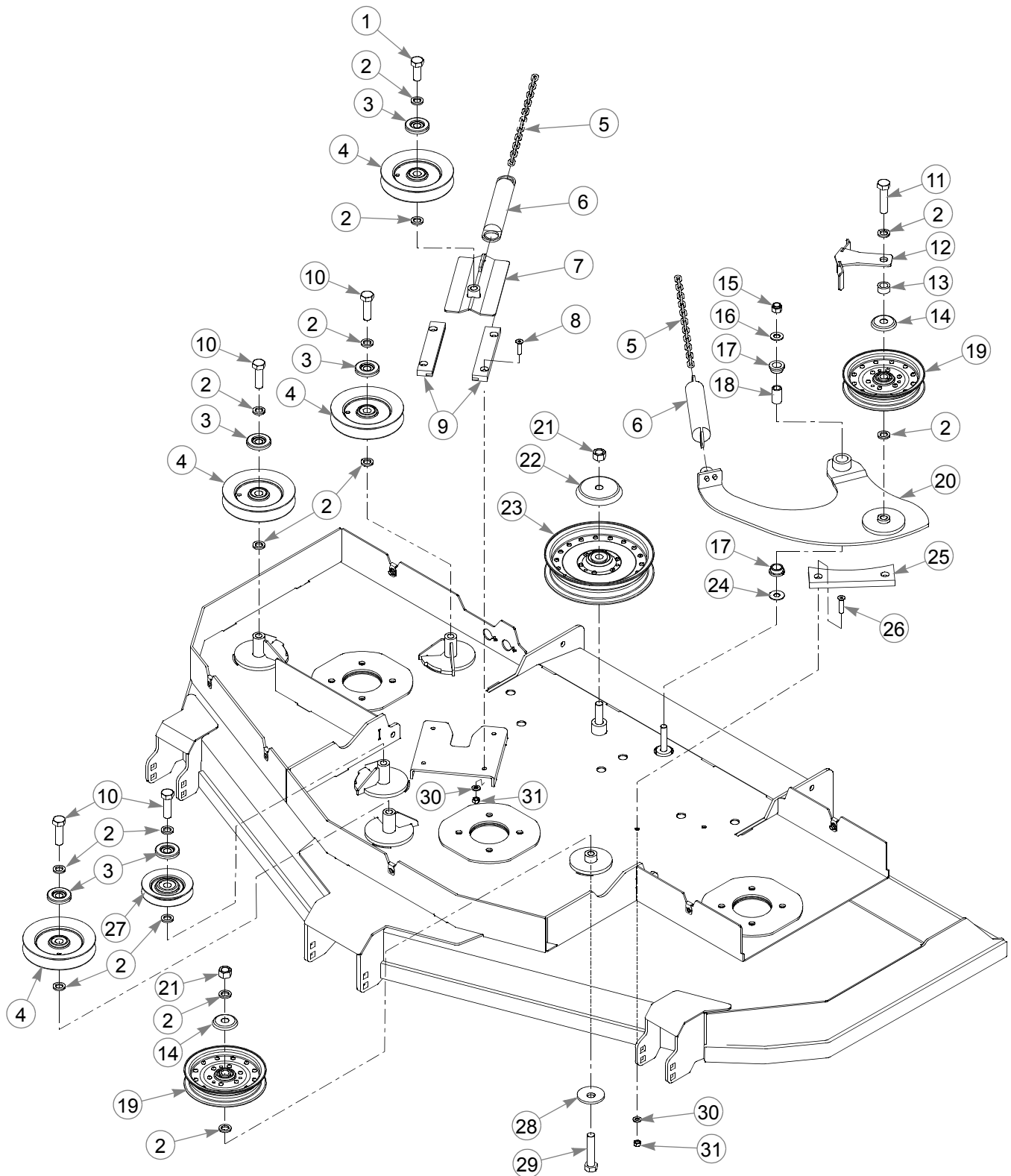

---

## **72" Rear Discharge Deck Pulleys & Spindles**

INDEX NO.	PART NO.	QTY.	DESCRIPTION
1	794446	1	CS .625-11 X 1.50 HX G5
2	028118	14	FW .625 X 1.00 X .134 ZNYC
3	603057	5	DUST SHIELD WITH OFFSET
4	602672	4	PULLEY V-IDLER HBB 5.0"
5	373191	2	CHAIN 21 LINK
6	781302	2	TENSION SPRING
7	114105	1	IDLER SLIDE
8	784199	4	CS .312-18 X 1.25 FLT SH
9	601619	2	IDLER SLIDE UHMW
10	016642	4	CS .625-11 X 2.00 HX G5 Z
11	025015	1	CS .625-11 X 2.50 HX G5
12	113088	1	BELT GUIDE
13	603256	1	DECK IDLER SPACER 1/2" LG
14	602935	2	IDLER DUST SHIELD SM
15	781567	1	NT .500-13 NL G5
16	767962	13	FW .531 X 1.063 X .090 SAE
17	770867	2	BUSHING
18	109549	1	BUSHING
19	602821	2	IDLER 6.0" RIVETED
20	114133	1	RD DECK IDLER ARM
21	016972	2	NT .625-11 HX G5 ZNYC
22	602963	1	IDLER DUST SHIELD LG
23	602838	1	IDLER 8.0" RIVETED
24	704759	1	FW .500 X 1.25 X .075 ZNY
25	601779	1	IDLER GUIDE
26	797910	2	CS .312-18 X 1.50 FLT SH ZY
27	788364	1	IDLER PULLEY NHI 4.288"
28	782474	1	CW .631 X 2.25 X .187 PNT
29	783738	1	CS .625-11 X 3.00 FULL HX G5
30	768523	6	FW .343 X .687 X .051/.080H
31	058776	6	NT .312-18 HX NL G5

---

### **NOTES:**

# 72" Rear Discharge Deck Pulleys & Spindles

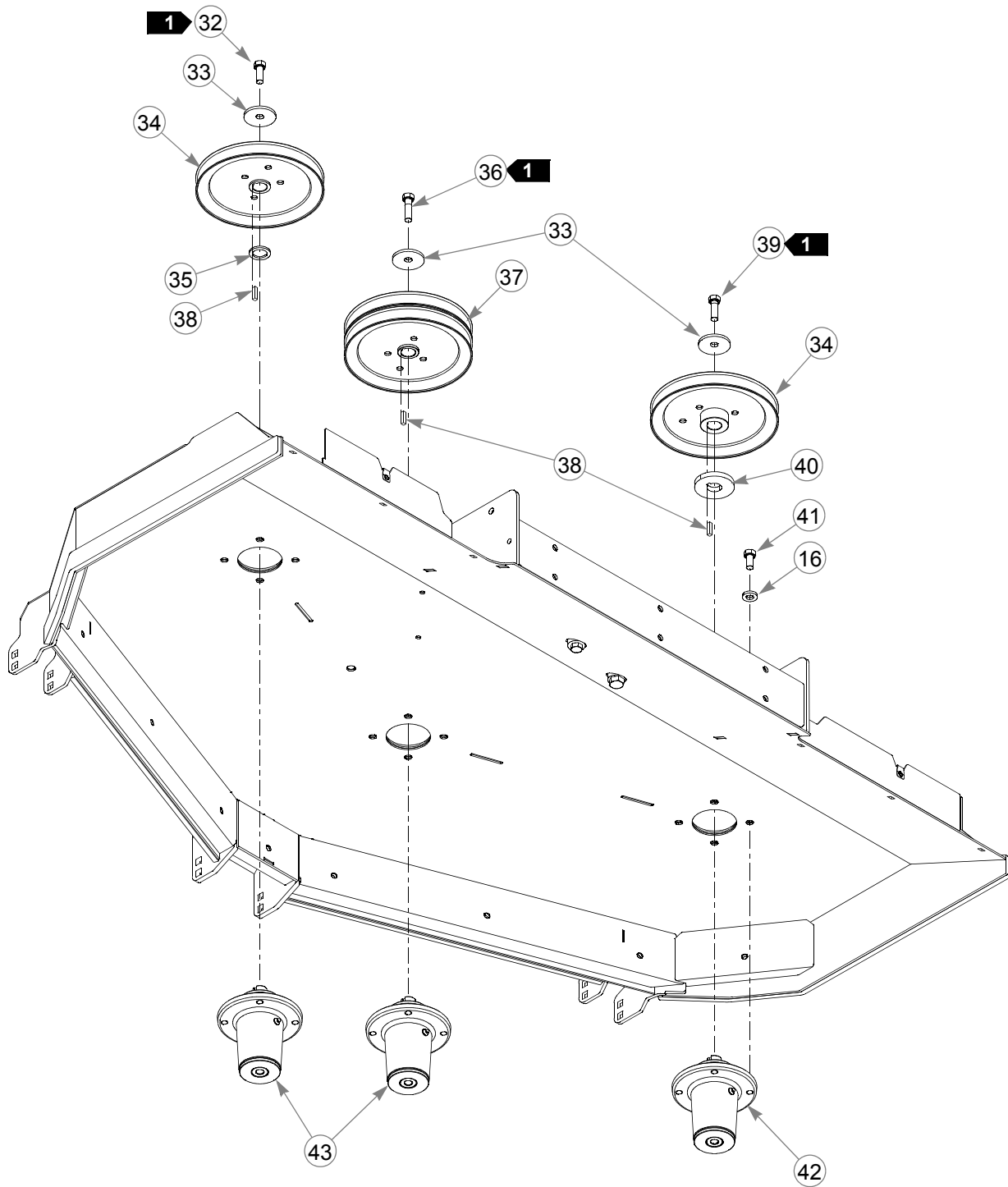

---

## **72" Rear Discharge Deck Pulleys & Spindles**

INDEX NO.	PART NO.	QTY.	DESCRIPTION
32	705954	1	CS .500-13 X 1.25 HS G5
33	752386	3	CW .515 X 2.25 X .204 BLK
34	602746	2	DRIVE PULLEY 8.652 OP
35	045765	1	FW 1.030 X 1.50 X .134
36	017616	1	CS .500-13 X 1.75 HX G5
37	603226	1	DOUBLE PULLEY 8.41"
38	212472	3	KEY 1/4 SQ X 1.00
39	074252	1	CS .500-13 X 1.50 HX G5
40	114108	1	SPACER
41	016527	12	CS .500-13 X 1.00 HX G5 ZN
42	604256	1	BLADE SPINDLE CCW (S/N 12092683 & HIGHER)
	601630	1	BLADE SPINDLE CCW (S/N PRIOR TO 12092683)
43	604255	2	BLADE SPINDLE CW (S/N 12092683 & HIGHER)
	601819	2	BLADE SPINDLE CW (S/N PRIOR TO 12092683)

---

### **NOTES:**

1. Torque to 65–75 ft-lbs.

# 72" Rear Discharge Dust Shield

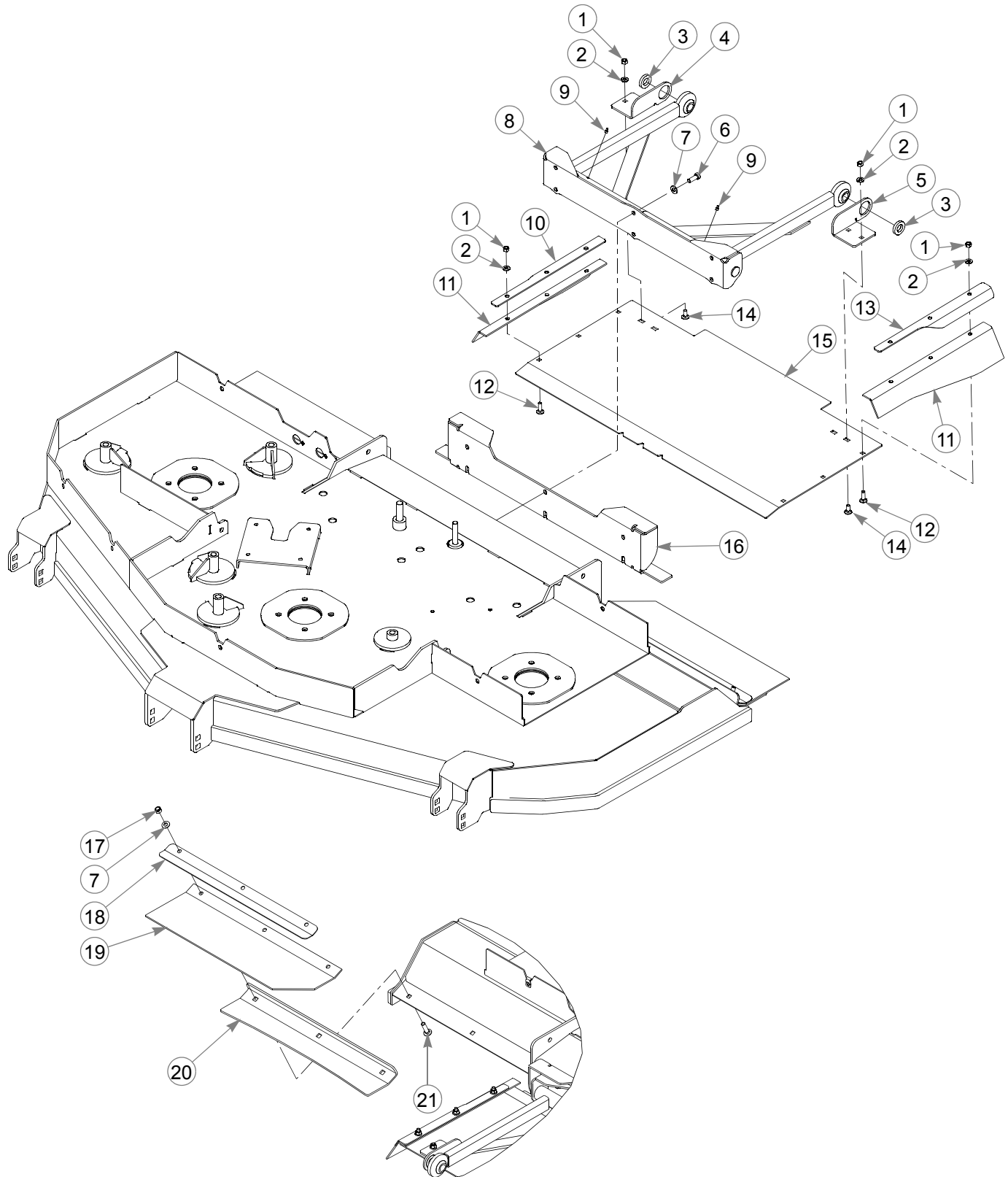



---

## **72" Rear Discharge Dust Shield**

INDEX NO.	PART NO.	QTY.	DESCRIPTION
1	058776	10	NT .312-18 HX NL G5
2	768523	10	FW .343 X .687 X .051/.080H
3	778399	2	FW .781 X 1.375 X .250 ZNY
4	109483	1	LS CHUTE BRACKET
5	109482	1	RS CHUTE BRACKET
6	036244	6	CS .375-16 X 1.00 HX G5
7	767954	12	FW .406 X .812 X .060 SAE
8	113340	1	PUSHER
9	015495	2	GREASE FITTING STRAIGHT
10	109487	1	RS CLAMP ANGLE
11	601483	2	RUBBER SIDE FLAP
12	037887	6	CB .312-18 X 1.00 FULL ZN
13	109486	1	LS CLAMP ANGLE
14	016253	4	CB .312-18 X .75 FUL ZN
15	114653	1	DUST SHIELD
16	114522	1	REAR DECK STOP
17	086660	6	NT .375-16 NL G5
18	107712	2	DISCHARGE CHUTE ANGLE
19	600930	2	REAR FLAP
20	101360	2	DECK STIFFENER ANGLE
21	710194	6	CB .375-16 X 1.50 STD G5

---

### NOTES:

# 72" Rear Discharge Deck

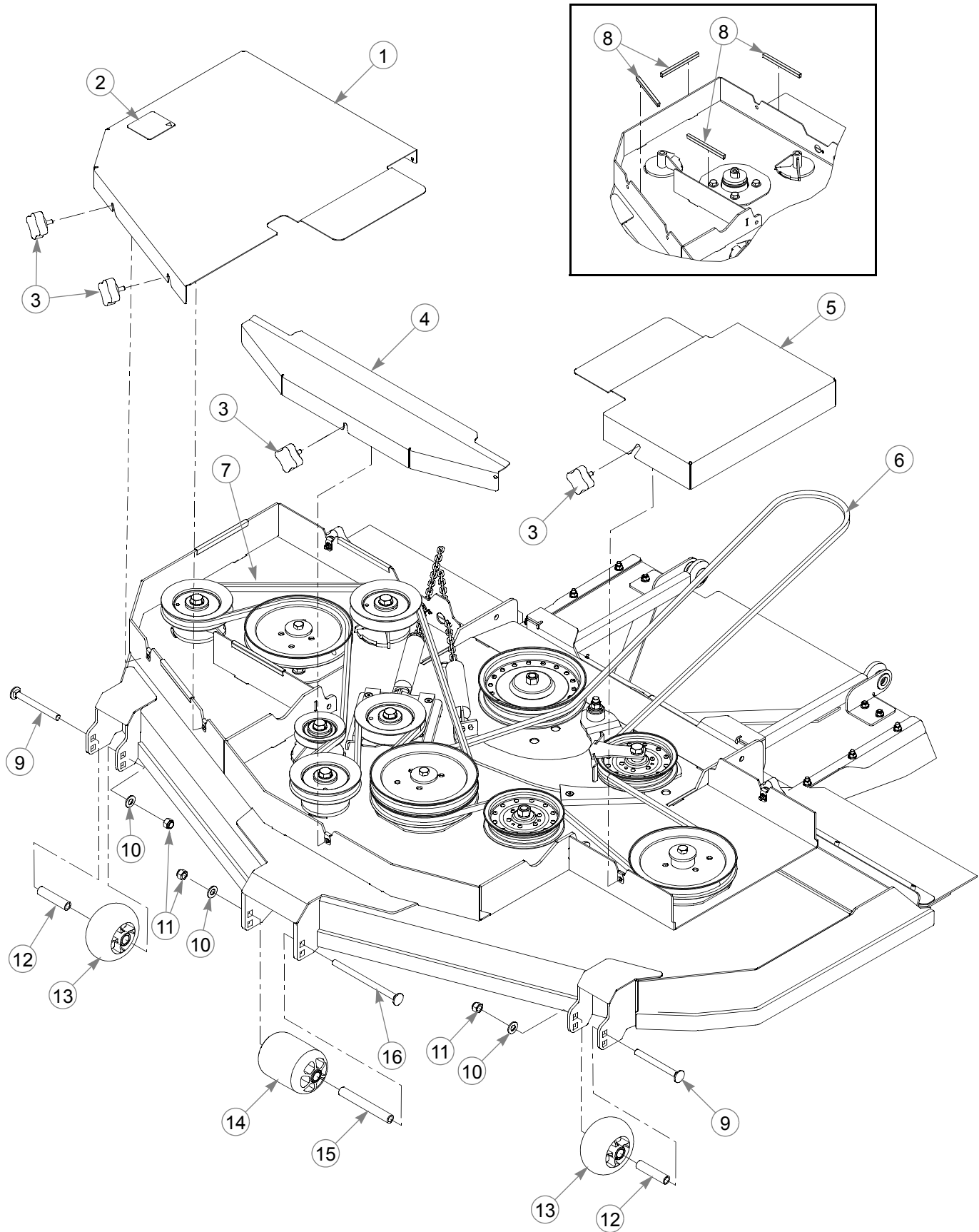

---

## **72" Rear Discharge Deck**

INDEX NO.	PART NO.	QTY.	DESCRIPTION
1	551050	1	RS PULLEY COVER (WITH DECAL)
2	601837	1	DECK DANGERS DECAL
3	792002	6	KNOB 5/16-18 X 3/4"
4	114209	1	CENTER PULLEY COVER
5	114490	1	LS PULLEY COVER
6	782292	1	BELT, B 165.56" EL
7	603422	1	BELT, HBB SECTION 140.3
8	111339	4	FLEX TRIM
9	603049	2	CB .500-13 X 5.00 ZNYC
10	767962	3	FW .531 X 1.063 X .090 SAE
11	781567	3	NT .500-13 NL G5
12	602345	2	SPACER 3.22
13	602263	2	PLASTIC WHEEL
14	602341	1	PLASTIC WHEEL
15	602344	1	SPACER 5.73
16	602338	1	CB .500-13 X 7.50 STD ZN

---

### **NOTES:**

# 72" Rear Discharge Deck

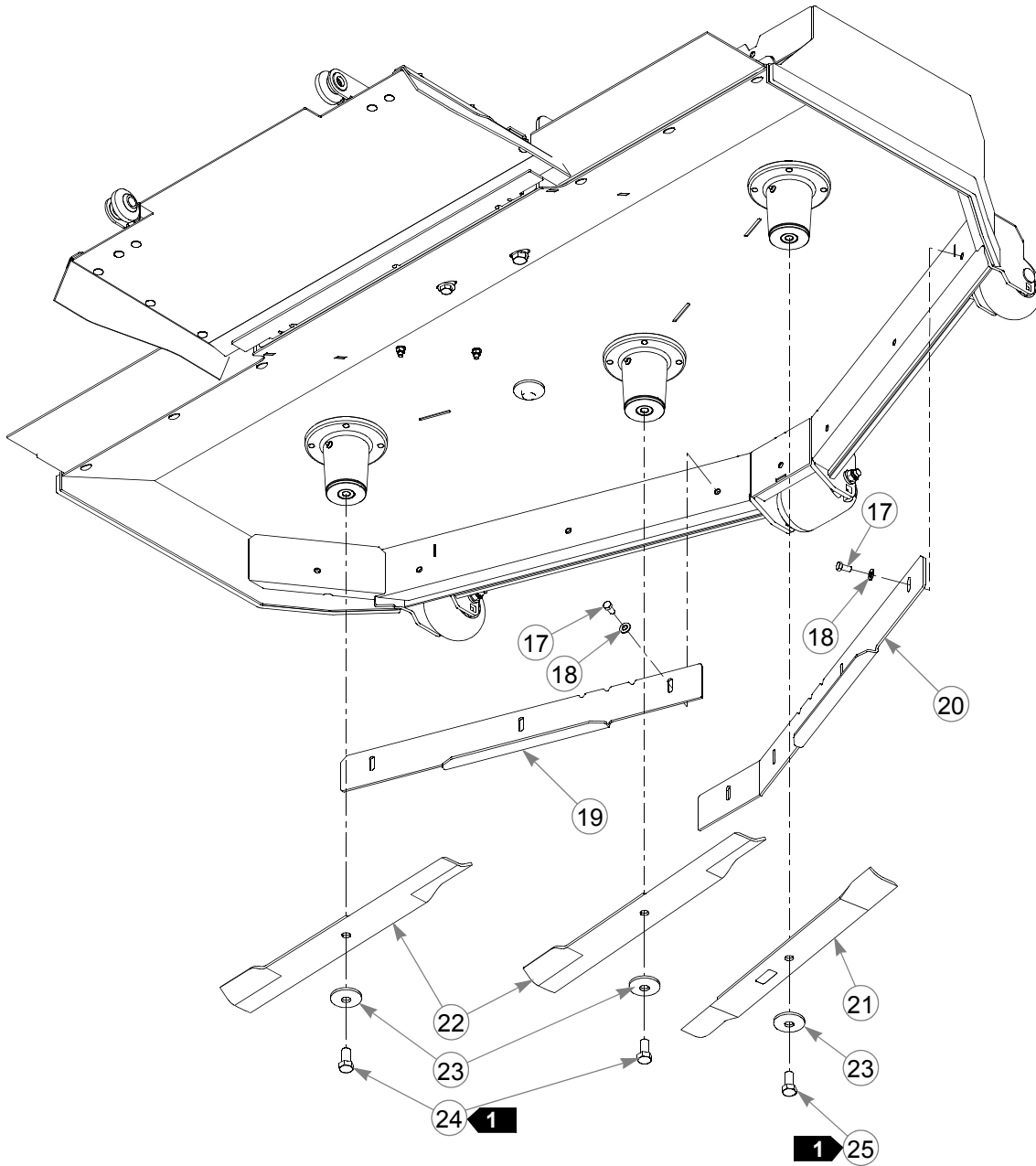

---

## **72" Rear Discharge Deck**

INDEX NO.	PART NO.	QTY.	DESCRIPTION
17	055822	7	CS .375-16 X .75 HX G5
18	767954	7	FW .406 X .812 X .060 SAE
19	114492	1	LS ADJUSTABLE BAFFLE
20	114491	1	RS ADJUSTABLE BAFFLE
21	796508	1	BLADE, F23.86-L-F-CCW
	601929	1	BLADE, 23.86" GAT-F-CCW
22	796839	2	BLADE, F23.86-L-F-CW
	794867	2	BLADE, 23.86"-GAT-F-CW
23	782474	3	CW .631 X 2.250 X .187 PNT
24	781872	2	CS .625-11 X 1.25 HX G5 Z (S/N 12092683 & HIGHER)
	601983	2	CS .625-11 X 2.25 HX G5 ZY (S/N PRIOR TO 12092683)
25	604383	1	CS .625-11 X 1.25 HX G5 LH THREAD (S/N 12092683 & HIGHER)
	601999	1	CS .625-11 X 2.25 LH HX G5 H5Y (S/N PRIOR TO 12092683)

---

### **NOTES:**

1. Torque to 118 ft-lbs.

# Rear Discharge Deck Lift

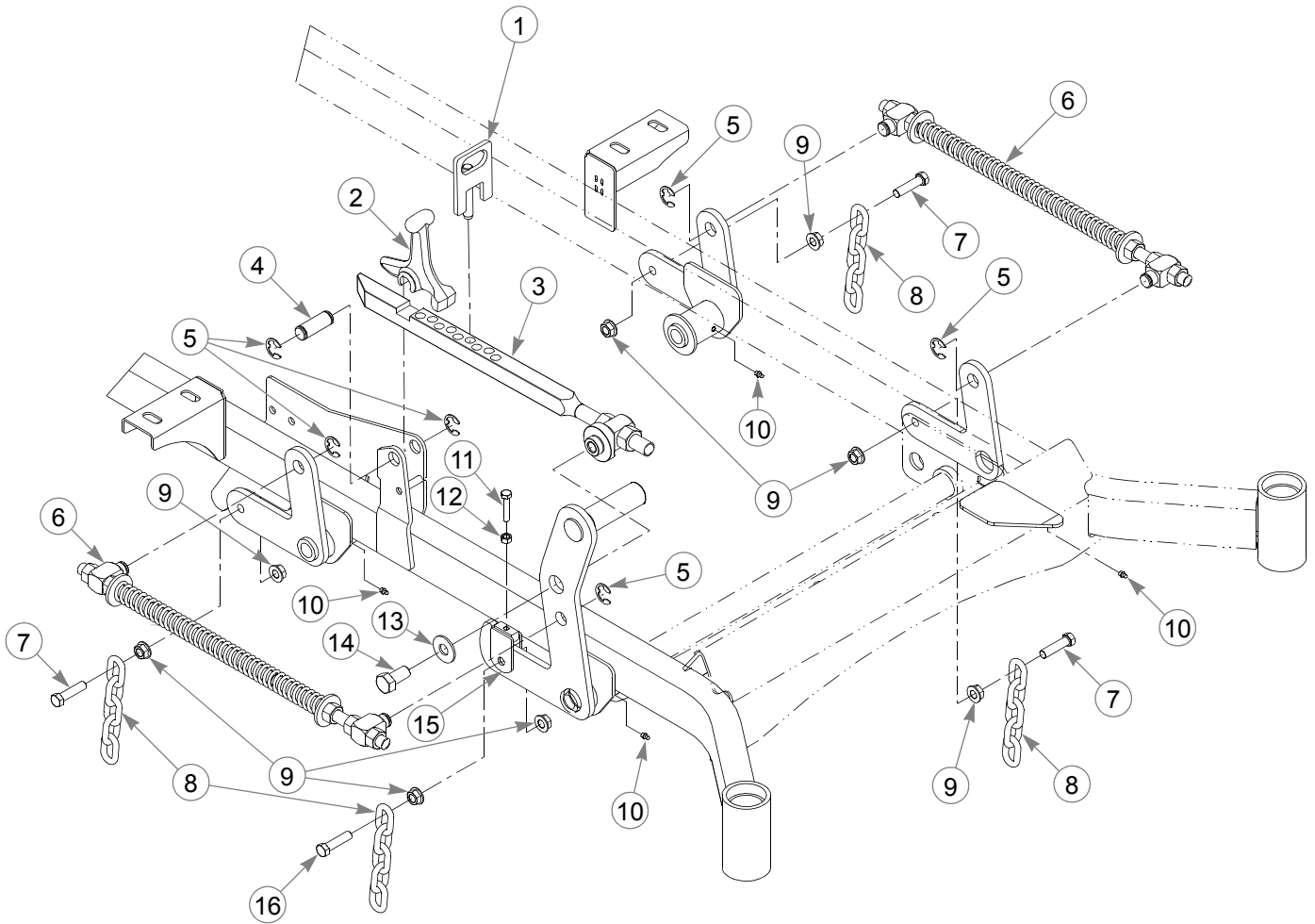

---

## **Rear Discharge Deck Lift**

INDEX NO.	PART NO.	QTY.	DESCRIPTION
1	600437	1	DECK HEIGHT PIN
2	348318	1	STOP HANDLE
3	602898	1	DECK LIFT INDICATOR
4	781229	1	CE .750 X 2.25 X 1.75 HEAD
5	781294	6	E CLIP 1.00 X .625 X .05
6	603184	2	DECK LIFT SPRING
7	055749	7	CS .437-14 X 1.75 HX G5
8	348391	4	DECK LIFT CHAIN
9	704643	16	NT .437-14 HX FLG ZN
10	015495	4	GREASE FITTING STRAIGHT
11	756270	1	CS .312-18 X 1.50 FLTHR HX
12	034272	1	NT .312-18 HX G5 ZNYC
13	704783	1	FW .625 X 1.50 X .105 ZN
14	781872	1	CS .625-11 X 1.25 HX G5 Z
15	348458	1	DECK LEVELER YOKE
16	781831	1	CS .437-14 X 1.75 FULTH

---

### **NOTES:**

# Rear Discharge Deck Mounting Hardware

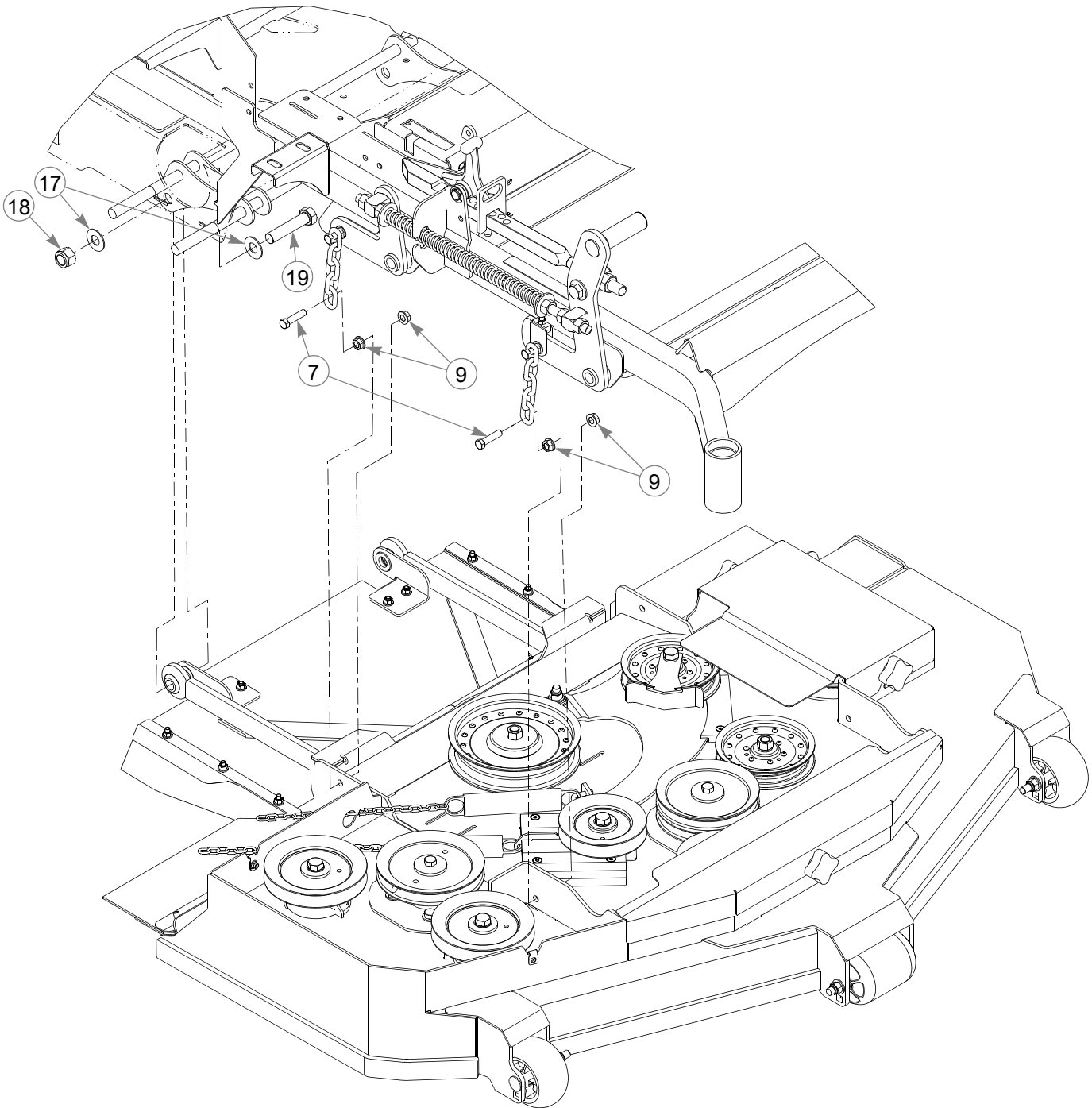



---

## **Rear Discharge Deck Mounting Hardware**

INDEX NO.	PART NO.	QTY.	DESCRIPTION
17	025296	4	FW .760 X 1.625 X .08 ZNYC
18	061101	2	NT .750-10 HX ZY NL
19	789115	2	CS .750-10 X 3.50 HX G5

---

### **NOTES:**



---

## Section 8

Seat, Super Deluxe . . . . .	8-2
Seat Service Parts, Super Deluxe . . . . .	8-4
Seat, Suspension. . . . .	8-6
Seat Service Parts, Suspension . . . . .	8-8
ROPS . . . . .	8-10

# Seat, Super Deluxe

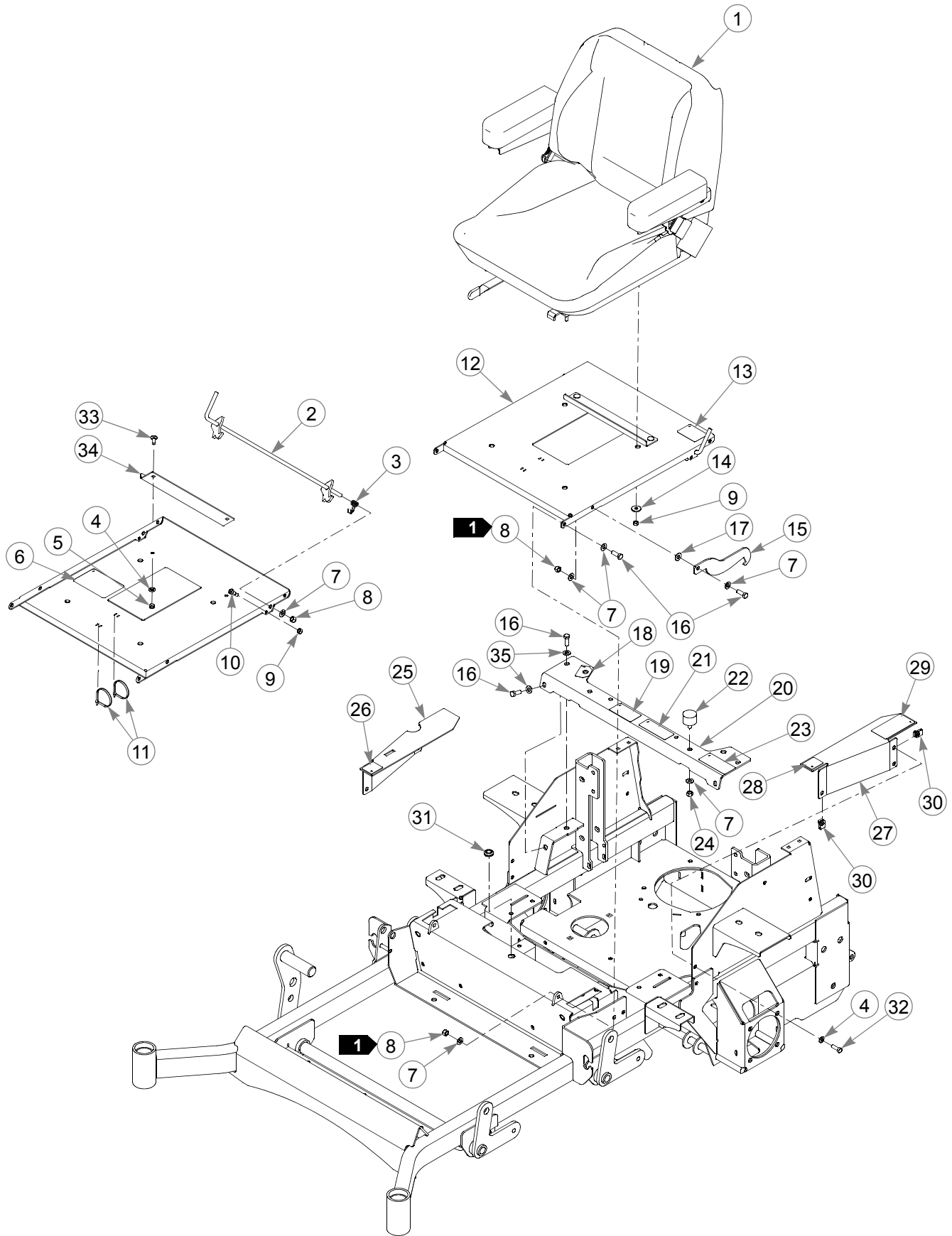

---

## **Seat, Super Deluxe**

INDEX NO.	PART NO.	QTY.	DESCRIPTION
1	602966	1	SUPER DELUXE SEAT
2	113157	1	SEAT LATCH
3	783910	1	TORSION SPRING
4	768523	7	FW .343 X .687 X .051/.080H
5	034272	2	NT .312-18 HX G5 ZNYC
6	601815	1	BATTERY WARNINGS DECAL
7	767954	11	FW .406 X .812 X .060 SAE
8	086660	5	NT .375-16 NL G5
9	058776	5	NT .312-18 HX NL G5
10	754358	1	SB .375 X .375 SH .312-18
11	000331	2	WIRE TIE
12	550815	1	SEAT PAN (WITH DECALS & INSTALLATION KIT)
13	785188	1	ARMREST WARNING DECAL
14	712927	4	FW .344 X 1.00 X .12 HRD Z
15	350421	2	SEAT PAN STOP
16	036244	8	CS .375-16 X 1.00 HX G5
17	724716	2	FIBER WASHER
18	791848	1	FUEL INDICATOR DECAL
19	601968	1	HYDRAULIC PRESSURE DECAL
20	550816	1	SEAT SUPPORT (WITH DECALS)
21	601058	1	HOT/SYN HYDRO OIL DECAL
22	601650	2	VIBRATION MOUNT
23	601967	1	ENGINE COMPARTMENT DECAL
24	054502	2	NT .375-16 HX G5 ZNY
25	550824	1	RS FRAME COVER (WITH DECALS)
26	785220	1	RS STEERING DECAL
27	550823	1	LS FRAME COVER (WITH DECALS)
28	785139	1	LS STEERING DECAL
29	600899	1	PUMP BELT WARNING DECAL
30	601069	5	CN .312-18 X .20 MAX THK
31	080358	1	GM .50 X 1.00 X .75 X .12
32	036236	5	CS .312-18 X 1.00 HX G5
33	016253	2	CB .312-18 X .75 FUL ZN
34	113713	1	SEAT STOP
35	712919	4	FW .406 X 1.00 X .12 HRD Z

---

### **NOTES:**

1. Do not torque; the seat pan & seat pan stop must pivot freely.

# **Seat Service Parts, Super Deluxe**

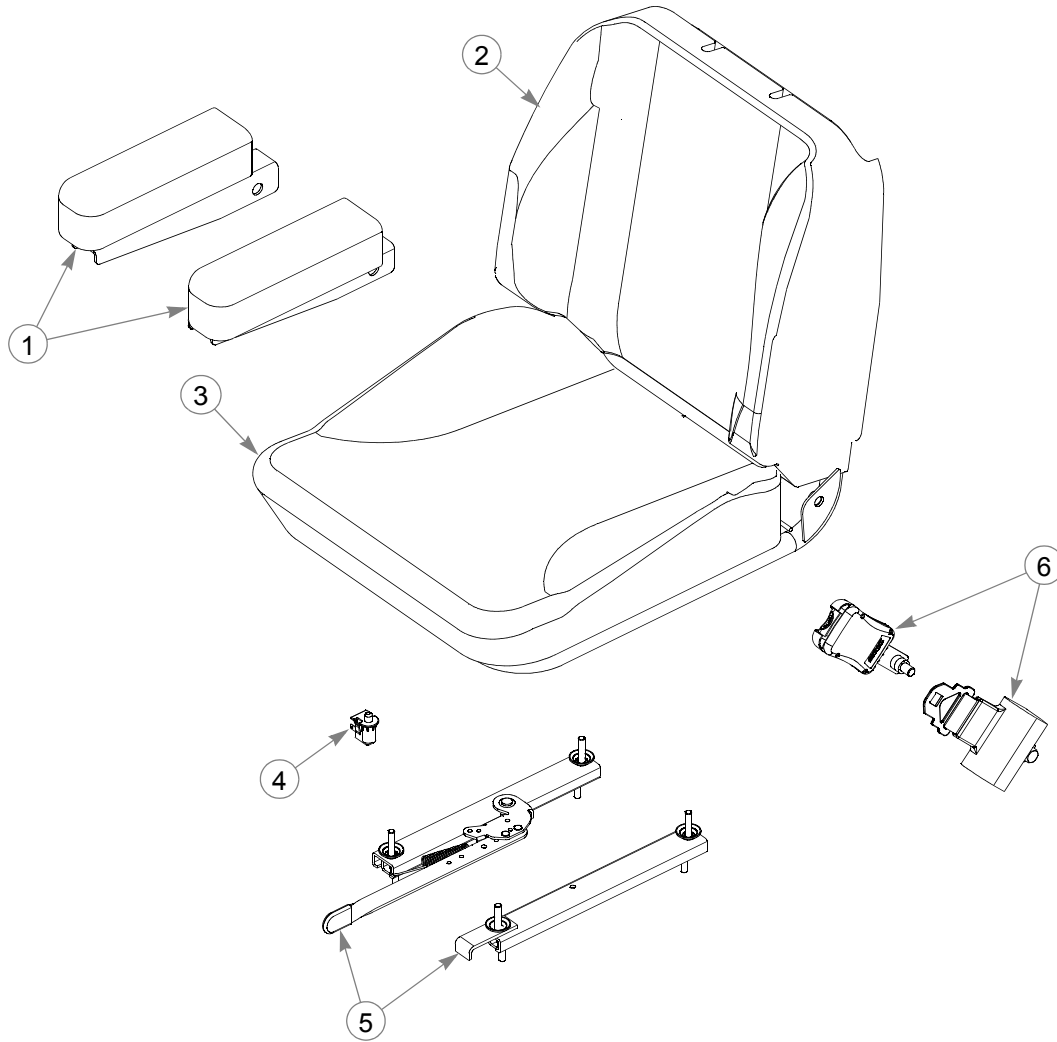

INDEX NO.	PART NO.	QTY.	DESCRIPTION
1	603260	1	ARMREST KIT
2	603694	1	BACK SEAT COVER
3	603693	1	BOTTOM SEAT COVER
4	603148	1	SEAT SWITCH
5	603146	1	STANDARD SEAT TRACK KIT
6	603133	1	SEAT BELT KIT

## **NOTES:**

---

**This page intentionally left blank.**

# Seat, Suspension

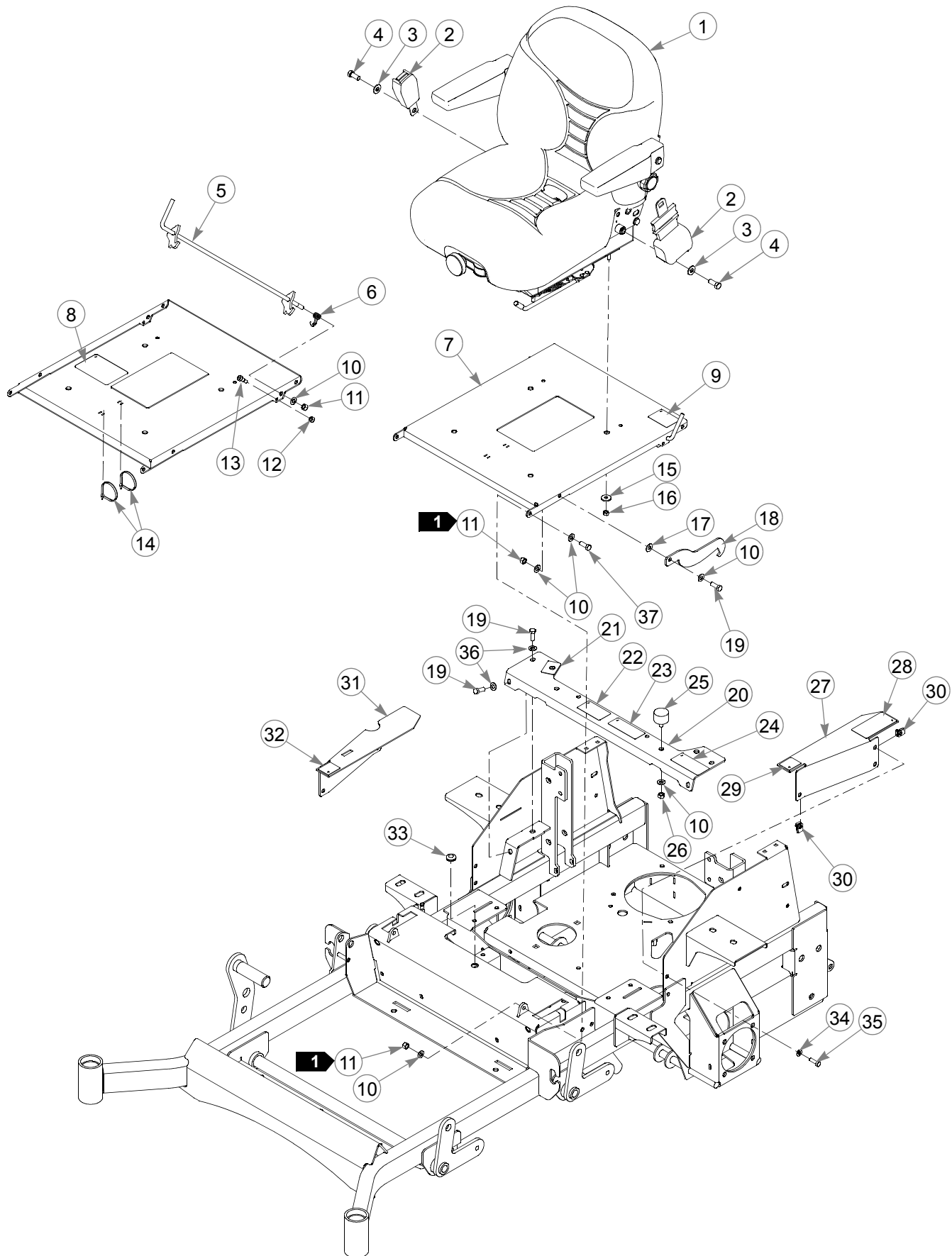



---

## **Seat, Suspension**

INDEX NO.	PART NO.	QTY.	DESCRIPTION
1	792051	1	SUSPENSION SEAT
2	601444	1	SEAT BELT
3	017129	2	FW .440 X 1.00 X .083 ZNY
4	797076	2	CS .437-20 X 1.00 HX G8 ZNYC
5	113157	1	SEAT LATCH
6	783910	1	TORSION SPRING
7	550815	1	SEAT PAN (WITH DECALS & INSTALLATION KIT)
8	601815	1	BATTERY WARNINGS DECAL
9	785188	1	ARMREST WARNING DECAL
10	767954	11	FW .406 X .812 X .060 SAE
11	086660	5	NT .375-16 NL G5
12	058776	1	NT .312-18 HX NL G5
13	754358	1	SB .375 X .375 SH .312-18
14	000331	2	WIRE TIE
15	712927	4	FW .344 X 1.00 X .12 HRD Z
16	058776	4	NT .312-18 HX NL G5
17	724716	2	FIBER WASHER
18	350421	2	SEAT PAN STOP
19	036244	6	CS .375-16 X 1.00 HX G5
20	550816	1	SEAT SUPPORT (WITH DECALS)
21	791848	1	FUEL INDICATOR DECAL
22	601968	1	HYDRAULIC PRESSURE DECAL
23	601058	1	HOT/SYN HYDRO OIL DECAL
24	601967	1	ENGINE COMPARTMENT DECAL
25	601650	2	VIBRATION MOUNT
26	054502	2	NT .375-16 HX G5 ZNY
27	550823	1	LS FRAME COVER (WITH DECALS)
28	600899	1	PUMP BELT WARNING DECAL
29	785139	1	LS STEERING DECAL
30	601069	5	CN .312-18 X .20 MAX THK
31	550824	1	RS FRAME COVER (WITH DECALS)
32	785220	1	RS STEERING DECAL
33	080358	1	GM .50 X 1.00 X .75 X .12
34	768523	5	FW .343 X .687 X .051/.080H
35	036236	5	CS .312-18 X 1.00 HX G5
36	712919	4	FW .406 X 1.00 X .12 HRD Z
37	052860	2	CS .375-16 X 1.25 HX G5

---

### **NOTES:**

1. Do not torque; the seat pan & seat pan stop must pivot freely.

# Seat Service Parts, Suspension

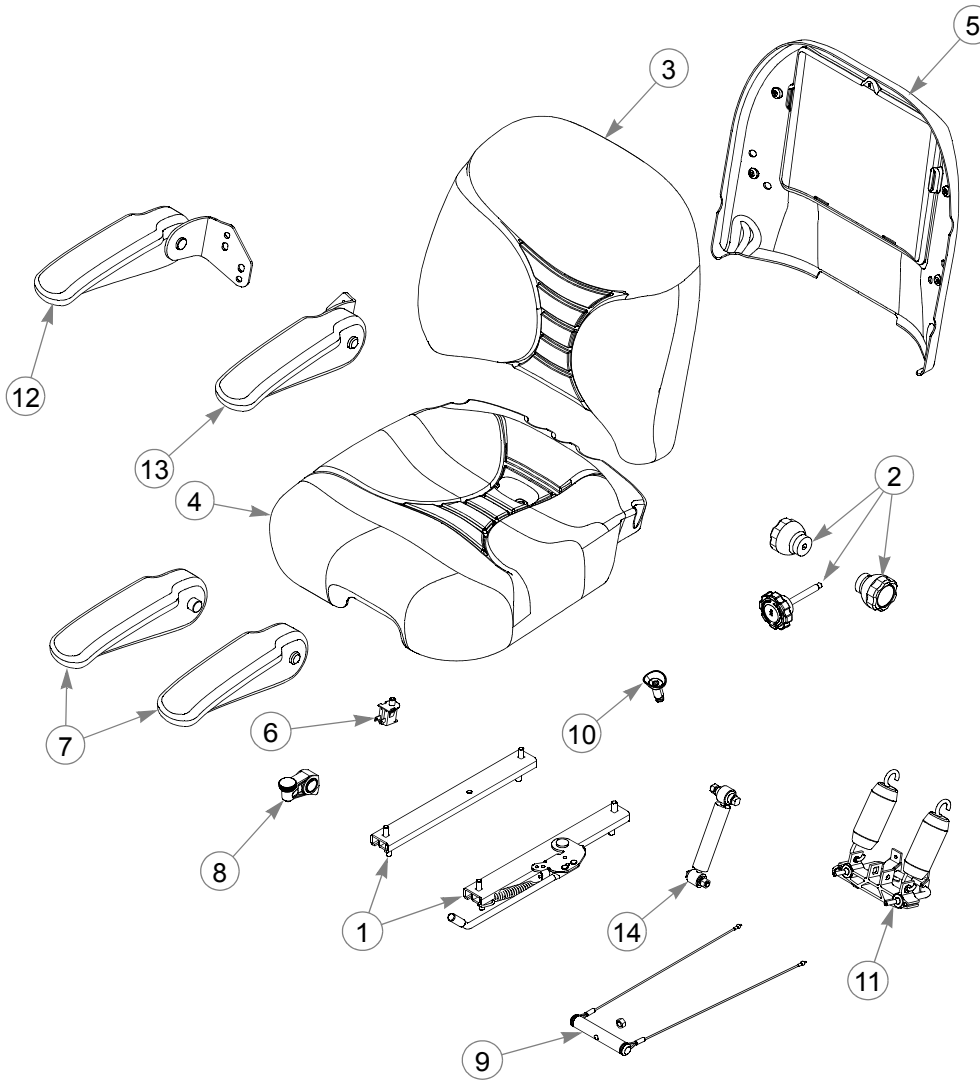

INDEX NO.	PART NO.	QTY.	DESCRIPTION
1	793307	1	SLIDE KIT
2	793323	1	KNOB KIT
3	793281	1	BACK CUSHION KIT
4	793299	1	BOTTOM CUSHION KIT
5	797571	1	SEAT BACK PANEL KIT
6	793315	1	SEAT SWITCH
7	797480	1	MOLDED ROUND ARMREST SET W/O BRACKET
8	793273	1	ARMREST STOP ASSEMBLY
9	601458	1	SEAT WEIGHT ADJUSTMENT KIT
10	602076	1	SEAT DRAIN REPLACEMENT
11	603040	1	SPRING SADDLE KIT
12	601533	1	RS ROUND ARMREST ASSEMBLY (WITH BRACKET)
13	601534	1	LS ROUND ARMREST ASSEMBLY (WITH BRACKET)
14	603152	1	SHOCK ABSORBER KIT

---

**This page intentionally left blank.**

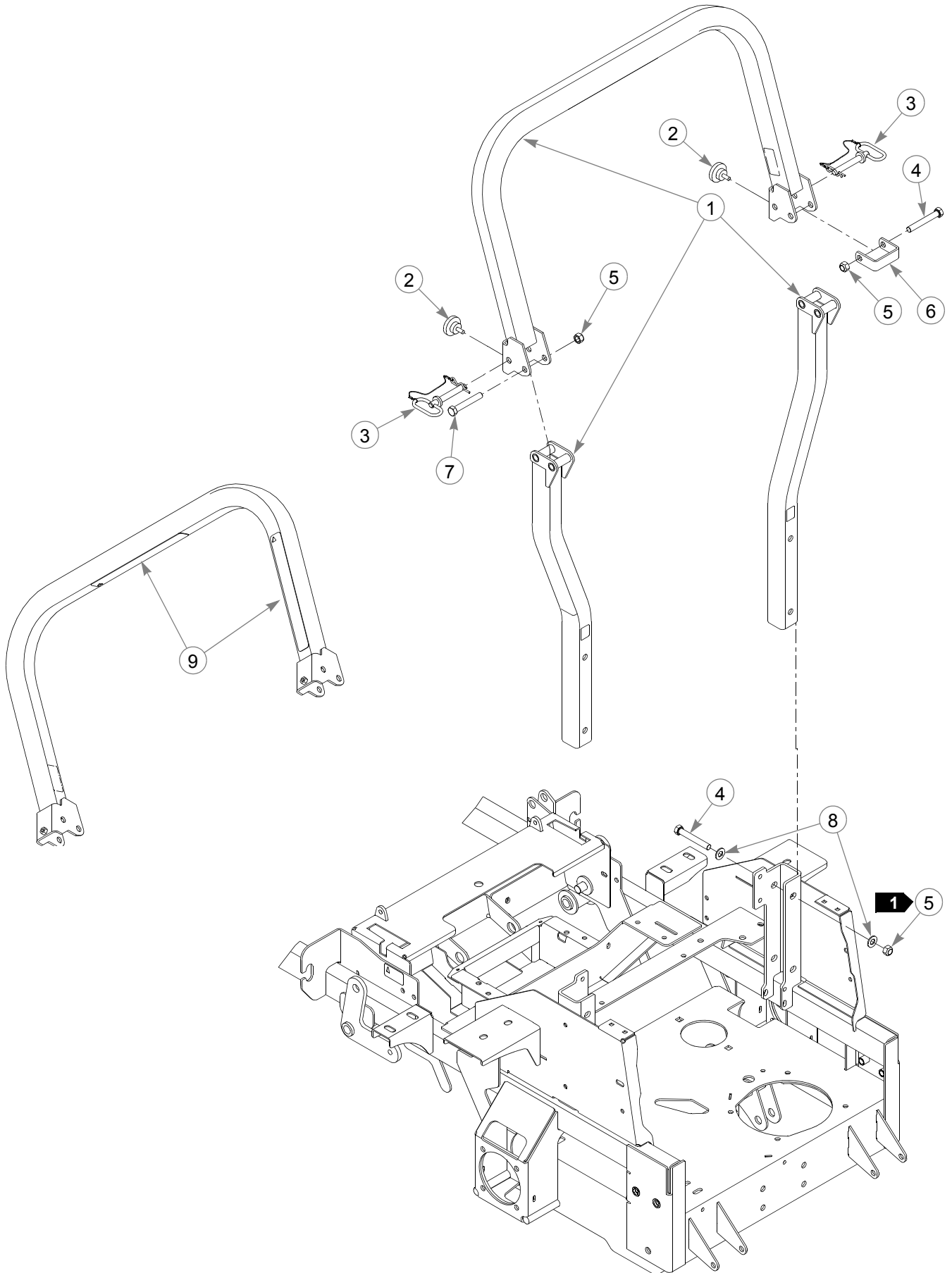

---

# **ROPS**

INDEX NO.	PART NO.	QTY.	DESCRIPTION
1	603338	1	ROPS KIT (WITH DECALS, SEATBELT & HARDWARE)
2	601470	2	HAND KNOB
3	601471	2	LYNCH PIN W/ LANYARD
4	061812	5	CS .500-13 X 3.50 HX G5
5	023317	6	NT .500-13 UNT LK G8 ZN
6	603099	1	ROPS STOP
7	077859	1	CS .500-13 X 3.25 HX G5
8	767962	8	FW .531 X 1.063 X .090 SAE
9	601635	2	ROPS DECAL

---

## **NOTES:**

1. Torque to 73 ft-lbs.

