

*Hustler[®] Super Z
Parts Manual*



HUSTLER[®]

ENGINEERING PERFORMANCE™

200 South Ridge Road
Hesston, Kansas
67062

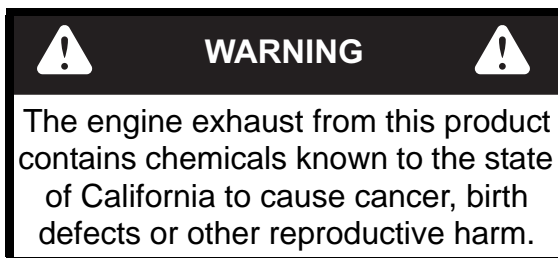

NOTICE OF REQUIREMENT OF SPARK ARRESTER MUFFLER

This equipment may create sparks that can start fires around dry vegetation. California Public Resources Code Section 4442.6 provides that it is unlawful to use or operate an internal combustion engine on any forest-covered, brush-covered, or grass-covered land unless the engine is equipped with a spark arrester maintained in effective working order. A spark arrester is a device constructed of nonflammable materials specifically for the purpose of removing and retaining carbon and other flammable particles over 0.0232 of an inch in size from the exhaust flow of an internal combustion engine that uses hydrocarbon fuels or which is qualified and rated by the United States Forest Service. Other states or federal areas may have similar laws. The Operator Should Contact Local Fire Agencies For Laws or Regulations Relating to Fire Prevention Requirements. **THIS EQUIPMENT DOES NOT HAVE A SPARK ARRESTER AND YOU SHOULD CONTACT YOUR AUTHORIZED DEALER FOR THE PURCHASE OF A SPARK ARRESTER.**

Inspect spark arrester daily; replace every 500 hours or as needed.

The Engine Owner's Manual provides information regarding the U.S. Environmental Protection Agency (EPA) and the California Emission Control Regulation of emission systems, maintenance and warranty.

Keep Engine Owner's Manual with your unit. Should the Engine Owner's Manual become damaged or illegible, replace immediately. Replacements may be ordered per the information found in the Product Information section of the owner's manual.

Federal law and California State law prohibit the following acts or the causing thereof:

1. The removal or rendering inoperative by any person other than for purposes of maintenance, repair, replacement, of any device or element of design incorporated into any equipment for the purposes of emissions control prior to or after its sales or delivery to the ultimate purchaser or while it is in use, or
2. The use of the equipment after such device or element of design has been removed or rendered inoperative by any person.

Table of Contents

General Information

Service Literature	1-1
Options Available From Your Dealer.	1-1
Using This Manual	1-1
Hardware Description Codes & Abbreviations	1-2
Standard Torques	1-2

Section 2

Frame	2-2
Engine Guard	2-4
Engine Guard—Kawasaki DFI	2-6
Decals—Models ending in “US”	2-8

Section 3

Hydraulic System	3-2
Hydraulic Reservoir.	3-4
Hydraulic Motor Service Parts.	3-6
Oil Cooler Mount.	3-8
Pump Drive	3-10
Steering—S/N 13034312 & Higher	3-12
Steering—S/N Prior to 13034312	3-14
Steering Assembly	3-18
Brake.	3-24

Section 4

Wheel & Tire	4-2
Front Wheel Assembly	4-4
Drive Wheel Breakdown	4-6

Section 5

Engine, Briggs & Stratton EFI	5-2
Engine Service Parts, Briggs & Stratton EFI.	5-4
Engine, Kawasaki FX801V	5-6
Engine, Kawasaki FX850V	5-10
Engine Service Parts, Kawasaki FX801V, FX850V	5-13
Engine, Kawasaki FX1000V	5-14
Engine, Kawasaki FX1000V DFI.	5-16
Engine Service Parts, Kawasaki FX1000V	5-18
Fuel System, Briggs & Stratton—With Carbon Canister.	5-20
Vapor System, Briggs & Stratton—With Carbon Canister	5-22
Fuel System, Kaw/Briggs & Stratton—W/O Carbon Canister.	5-24
Fuel System, Kawasaki—With Carbon Canister.	5-26
Vapor System, Kawasaki—With Carbon Canister	5-28
Fuel System, Kawasaki—DFI	5-30
Fuel Tank Service Parts—S/N 14044000 & Higher	5-32
Fuel Tank Service Parts—S/N Prior to 14044000.	5-33

Section 6

Battery	6-2
Instrument Panel—Briggs & Stratton Engines	6-4
Instrument Panel—Kawasaki Engines	6-6
Instrument Panel—Kawasaki DFI Engines.	6-8

Section 7

54" Side Discharge Service Deck.	7-2
54" Side Discharge Deck Pulleys & Spindles.	7-4
54" Side Discharge Deck	7-6
60" Side Discharge Service Deck.	7-8
60" Side Discharge Deck Pulleys & Spindles.	7-10
60" Side Discharge Deck	7-12
66" Side Discharge Service Deck.	7-14
66" Side Discharge Deck Pulleys & Spindles.	7-16
66" Side Discharge Deck	7-18
72" Side Discharge Service Deck.	7-20
72" Side Discharge Deck Pulleys & Spindles.	7-22
72" Side Discharge Deck	7-24
60" Rear Discharge Service Deck	7-26
60" Rear Discharge Deck Pulleys & Spindles	7-28
60" Rear Discharge Dust Shield.	7-32
60" Rear Discharge Deck.	7-34
72" Rear Discharge Service Deck	7-38
72" Rear Discharge Deck Pulleys & Spindles	7-40
72" Rear Discharge Dust Shield.	7-44
72" Rear Discharge Deck.	7-46
Deck Lift	7-50
Deck Mounting Hardware.	7-52

Section 8

Seat, Super Deluxe	8-2
Seat Service Parts, Super Deluxe	8-4
Seat, Suspension—S/N 15010001 & Higher	8-6
Seat, Suspension—S/N Prior to 15010001	8-8
Seat Service Parts, Suspension—S/N 150100001 & Higher	8-10
Seat Service Parts, Suspension—S/N Prior to 150100001	8-11
ROPS—S/N 15010001 & Higher	8-12
ROPS—S/N Prior to 15010001	8-14

General Information

This manual covers Hustler® Super Z models: **932012, 932020, 932038, 932046, 932053, 932061, 932129, 932137, 932368US, 932376US, 932970, 932988, 933457, 933911US, 934182US, 934208US, 934216, 934224, 934232, 934240, 934257, 934265, 934273 & 934299.**

Service Literature

PART NO.	DESCRIPTION
604437	OPERATOR'S MANUAL (S/N PRIOR TO 15010000)
605783	OPERATOR'S MANUAL (S/N 15010000 & HIGHER)
117586	WARRANTY STATEMENT
113855	CALIFORNIA EMISSIONS WARRANTY STATEMENT
117588	GENERAL SERVICE MANUAL

Options Available From Your Dealer

PART NO.	DESCRIPTION	PART NO.	DESCRIPTION
932103	BAC-VAC CATCHER	113679	60" SAND KIT
932467	3 BAG CATCHER	113908	66" SAND KIT
113903	60" ADAPTOR KIT	113909	72" SAND KIT
113904	66" ADAPTOR KIT	116840	ROLLER KIT (60" DECKS)
113905	72" ADAPTOR KIT	116842	ROLLER KIT (66" & 72" DECKS)
113722	60" MULCH KIT	113911	REAR DUAL ANTI-SCALP KIT (60" & 66" DECKS)
113723	66" MULCH KIT	113910	REAR SINGLE ANTI-SCALP KIT
113724	72" MULCH KIT	113937	REAR DUAL ANTI-SCALP KIT (72" DECKS)
603167	FLEX FORK KIT	116305	VX4 DECK HIGH VACUUM KIT (60" DECKS)
113932	HYDRO DECK LIFT KIT	116306	VX4 DECK HIGH VACUUM KIT (66" DECKS)
789537	SEMI-PNEUMATIC TIRE/WHEEL	116306	VX4 DECK HIGH VACUUM KIT (72" DECKS)
353961	STEERING EXTENSION KIT		

Note: When ordering parts, you must use the part number as shown for each part, not the index number. Always give the model and serial number to your parts and service representative.

Note: Items sold in bulk such as seals and hoses are sold by the foot.

Using This Manual

This manual is part of a service package for the Hustler® mowers. Use of this manual in conjunction with other Hustler® mower and component manuals will provide the information necessary to service and maintain Hustler® mowers.

This Parts Manual provides a complete parts listing for the unit. Use this manual when ordering parts. Illustrations used were current at the time of printing, but subsequent production changes may cause your machine to vary slightly in detail. Excel Industries, Inc. reserves the right to redesign and change the machine as deemed necessary, without notification. If a change has been made to your machine which is not reflected in this parts manual, see your authorized dealer for current information and parts.

The Service Manual is a service guide for use by Service Technicians. It provides the necessary information needed to perform normal maintenance requirements on these units.

The Operator's Manual provides fundamental operational information and operational safety that is needed when operating the mower.

The component manuals are furnished by the various manufacturers to be used for the troubleshooting and servicing of their products.

Hardware Description Codes & Abbreviations

The following codes are used throughout this parts manual. Refer to this list when ordering parts.

ABBREVIATION	DESCRIPTION	ABBREVIATION	DESCRIPTION
CB	CARRIAGE BOLT	MB	MACHINE BUSHING
CE	CLEVIS PIN	MS	MACHINE SCREW
CN	CLIP NUT	NT	NUT
CP	COTTER PIN	SC	SELF TAPPING CAP SCREW
CS	CAP SCREW	SH	SOCKET HEAD
CW	CUP WASHER	SB	SHOULDER BOLT
FDRW	FENDER WASHER	SS	SET SCREW
FW	FLAT WASHER	OD	OUTSIDE DIAMETER
HX	HEX HEAD	ID	INSIDE DIAMETER
LW	LOCK WASHER	WN	WELD NUT

Standard Torques

The following chart lists the standard torque values for the threaded fasteners found in this manual. Torque all cap screws, nuts and set screws to these values unless a different torque is shown in the Notes section next to the fastener.

SIZE	FT-LBS	N•M	SIZE	FT-LBS	N•M
.250	8.2	11.1	M3	1	1.3
.312	17	23	M4	2.2	3
.375	30	40	M5	4.5	6.1
.438	48	65	M6	7.7	10.4
.500	73	99	M8	18.5	25
.562	105	143	M10	37	50
.625	145	200	M12	64	87
.750	260	350	M14	80	108.5
.875	420	565	M16	160	215
1.00	625	850	M20	320	435
			M24	555	750

Section 2

Frame	2-2
Engine Guard.....	2-4
Engine Guard—Kawasaki DFI.....	2-6
Decals—Models ending in “US”	2-8

Frame

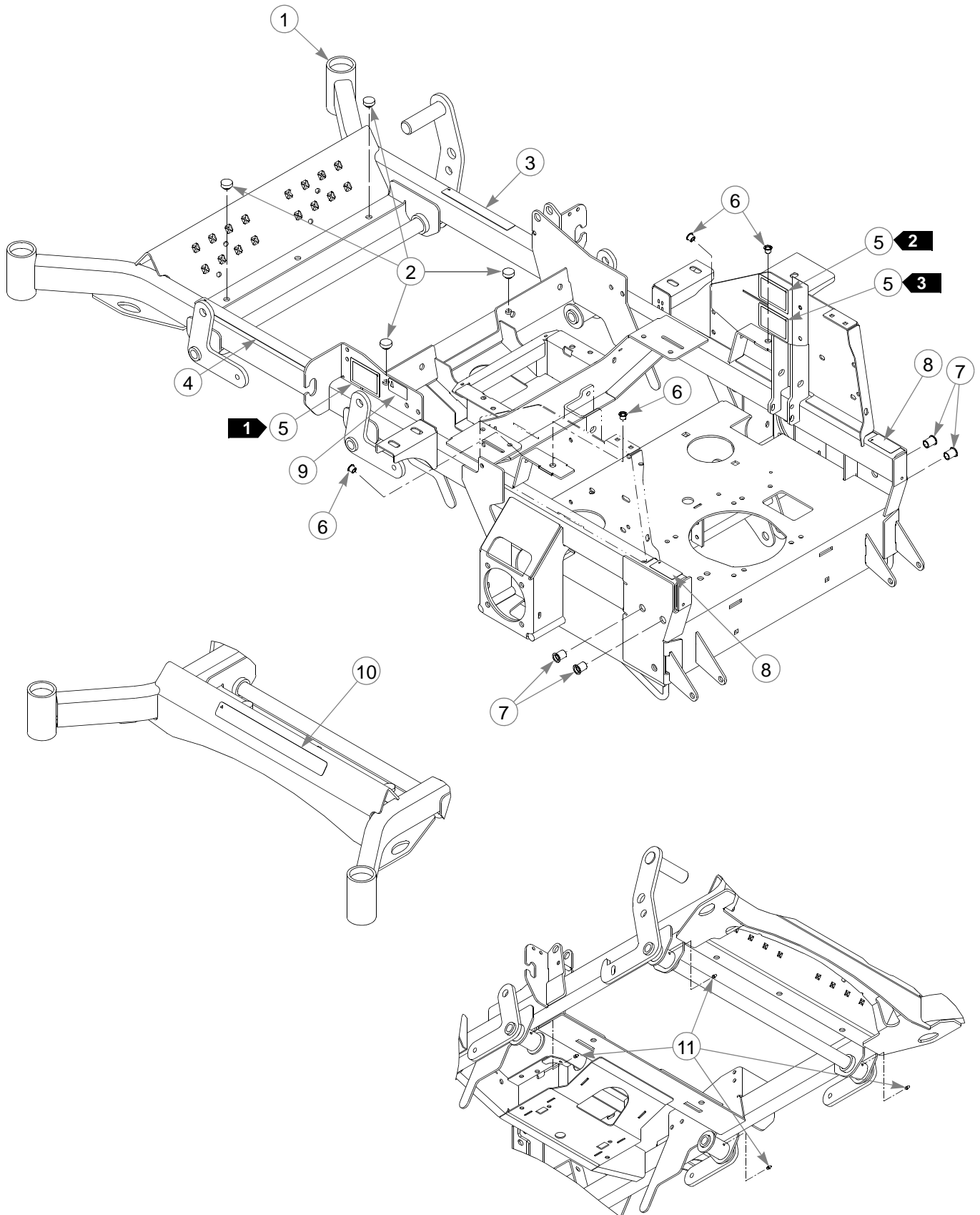

Frame

INDEX NO.	PART NO.	QTY.	DESCRIPTION
1	553135	1	54" SD FRAME (WITH DECALS, RIVET NUTS, BUMPERS & GREASE FITTINGS)
	551763	1	60" SD FRAME (WITH DECALS, RIVET NUTS, BUMPERS & GREASE FITTINGS)
	551765	1	72" SD FRAME (WITH DECALS, RIVET NUTS, BUMPERS & GREASE FITTINGS)
	551766	1	60" RD FRAME (WITH DECALS, RIVET NUTS, BUMPERS & GREASE FITTINGS)
	551767	1	72" RD FRAME (WITH DECALS, RIVET NUTS, BUMPERS & GREASE FITTINGS)
2	781880	4	BUMPER
3	781427	1	DECK HEIGHT DECAL
4	601993	1	SAFE OPERATION DECAL
5	N/A	3	SERIAL NUMBER / SPEC DECAL
6	808493	4	3/8-16 THREAD RIVET NUT
7	600961	4	1/2-13 THREAD RIVET NUT
8	602041	2	HOT DECAL
9	727172	1	MADE IN USA DECAL
10	602407	1	HUSTLER ID DECAL
11	015495	4	GREASE FITTING STRAIGHT

NOTES:

1. Serial number decal. In the event the serial number decal becomes damaged or illegible, please contact your dealer to order a replacement.
2. EPA compliance decal.
3. Patent numbers decal.

Engine Guard

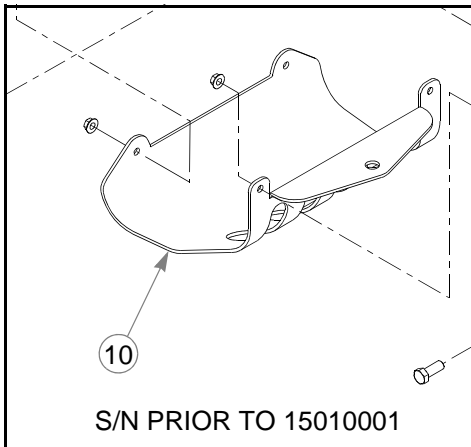
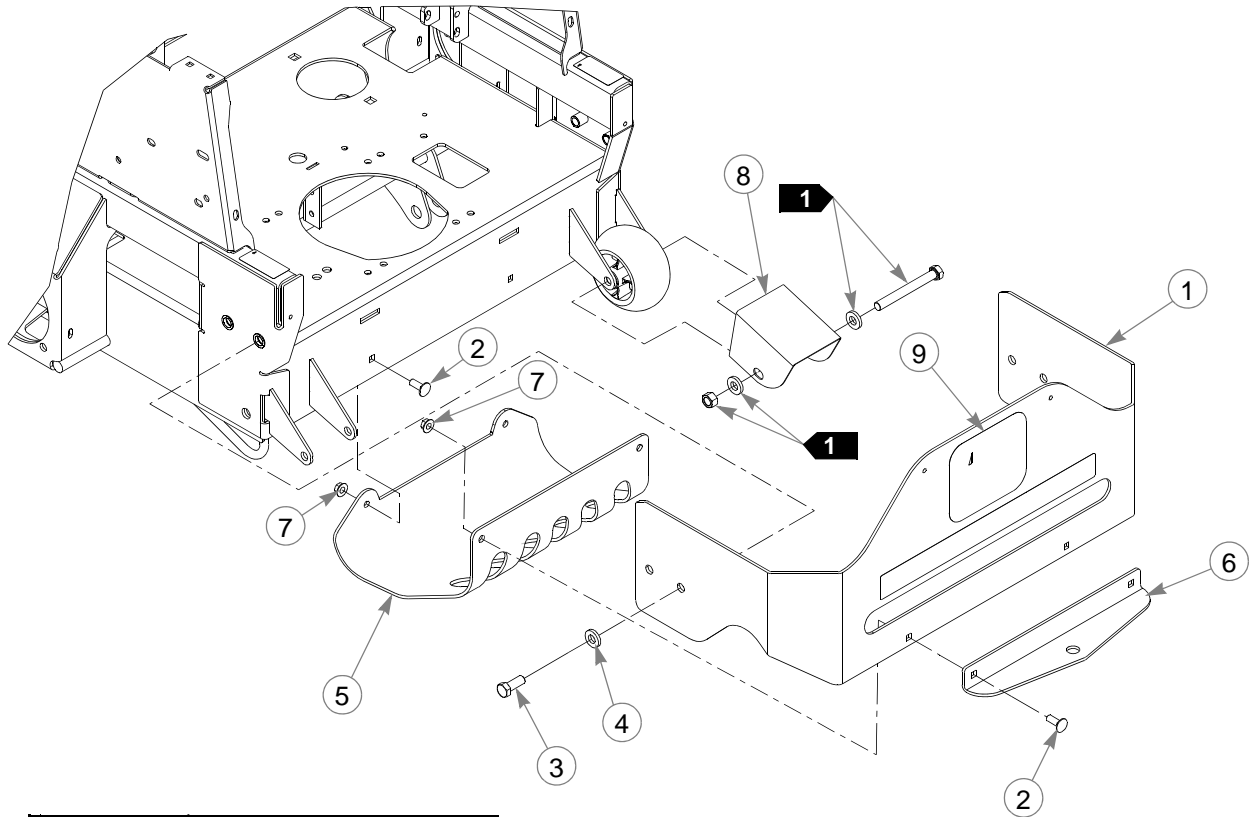

Engine Guard

INDEX NO.	PART NO.	QTY.	DESCRIPTION
1	118933	1	ENGINE GUARD
2	025395	4	CB .375-16 X 1.00 G5 ZNY
3	705954	4	CS .500-13 X 1.25 HX G5
4	767962	4	FW .531 X 1.063 X .175
5	121374	1	MUFFLER SHIELD (S/N 15010001 & HIGHER)
6	121375	1	HITCH PLATE (S/N 15010001 & HIGHER)
7	016899	4	NT .375-16 HX FLK G5
8	377994	2	SHIELD
9	604352	1	H LOGO DECAL
10	115905	1	HITCH (S/N PRIOR TO 15010001)

NOTES:

1. See the Wheel & Tire section.

Engine Guard—Kawasaki DFI

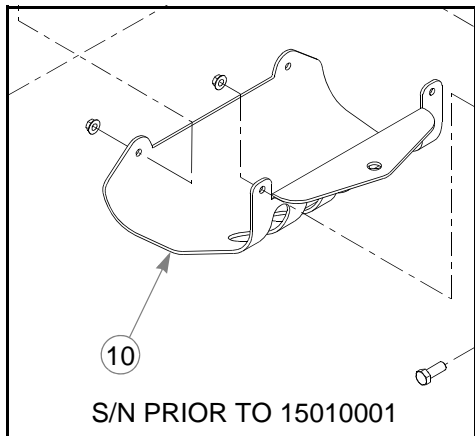
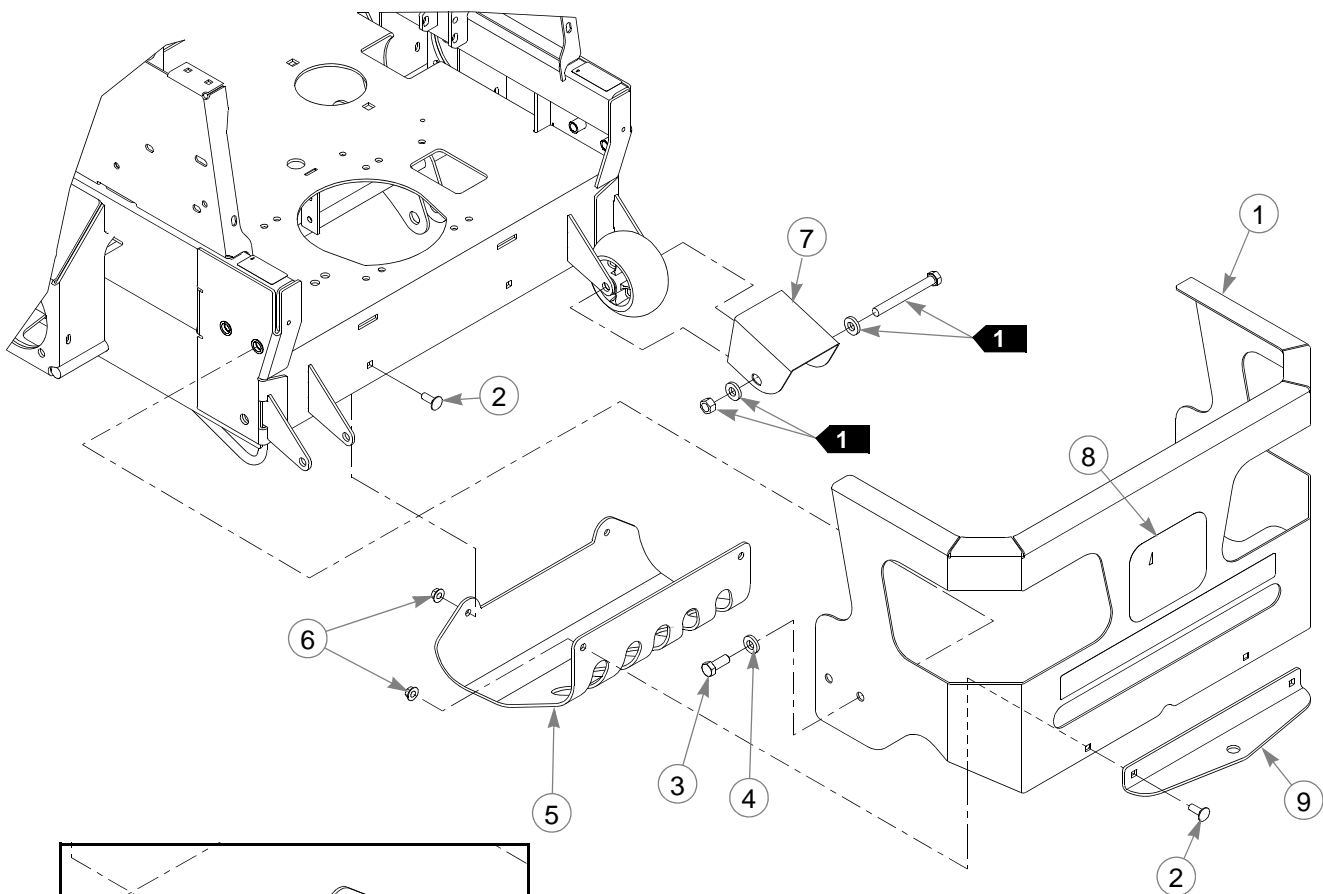

Engine Guard—Kawasaki DFI

INDEX NO.	PART NO.	QTY.	DESCRIPTION
1	552775	1	ENGINE GUARD
2	025395	4	CB .375-16 X 1.00 G5 ZNY
3	705954	4	CS .500-13 X 1.25 HX G5
4	767962	4	FW .531 X 1.063 X .175
5	121374	1	MUFFLER SHIELD (S/N 15010001 & HIGHER)
6	016899	4	NT .375-16 HX FLK G5
7	377994	2	SHIELD
8	604352	1	H LOGO DECAL
9	121375	1	HITCH PLATE (S/N 15010001 & HIGHER)
10	115905	1	HITCH (S/N PRIOR TO 15010001)

NOTES:

1. See the Wheel & Tire section.

Decals—Models ending in “US”

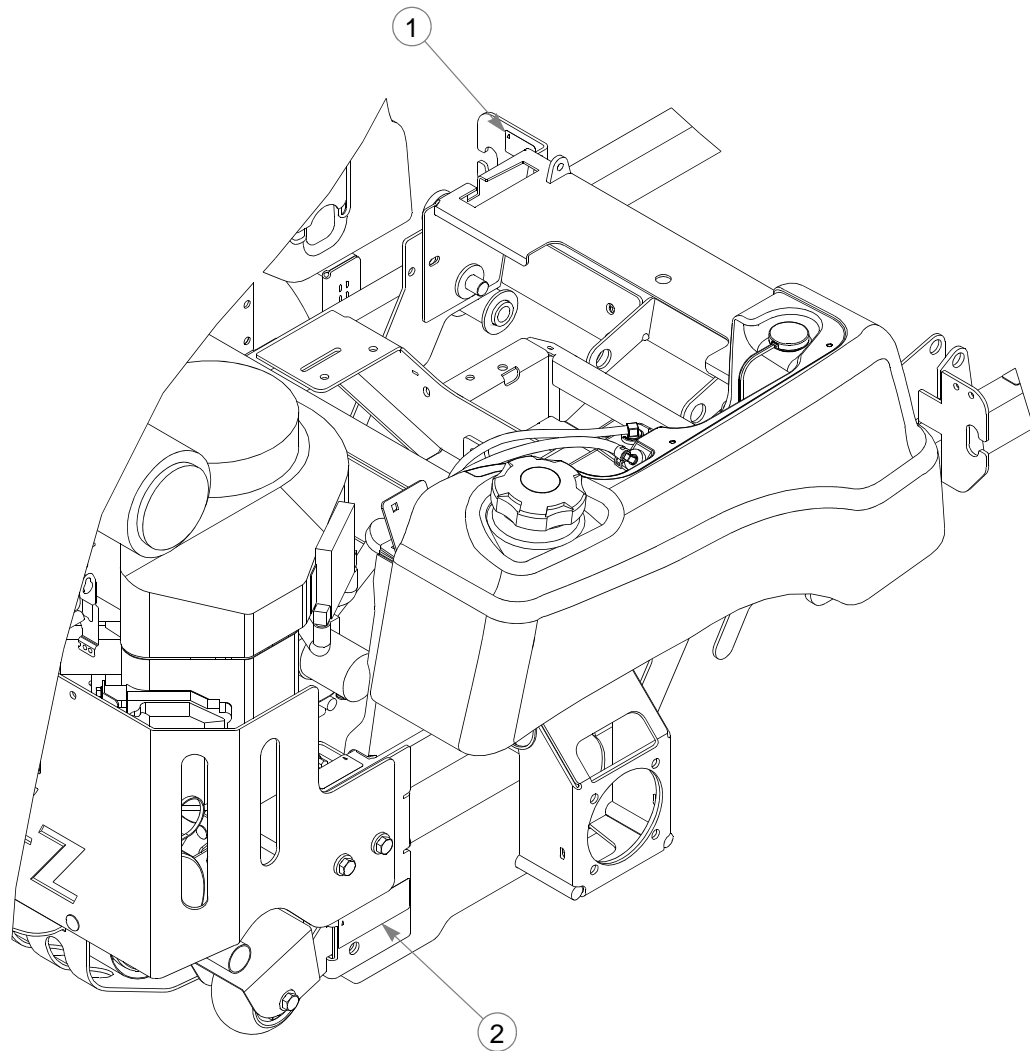

INDEX NO.	PART NO.	QTY.	DESCRIPTION
1	603363	1	ANSI COMPLIANCE DECAL
2	601908	1	SPARK ARRESTER DECAL

NOTES:

Section 3

Hydraulic System	3-2
Hydraulic Reservoir	3-4
Hydraulic Motor Service Parts	3-6
Oil Cooler Mount	3-8
Pump Drive	3-10
Steering—S/N 13034312 & Higher	3-12
Steering—S/N Prior to 13034312	3-14
Steering Assembly	3-18
Brake	3-24

Hydraulic System

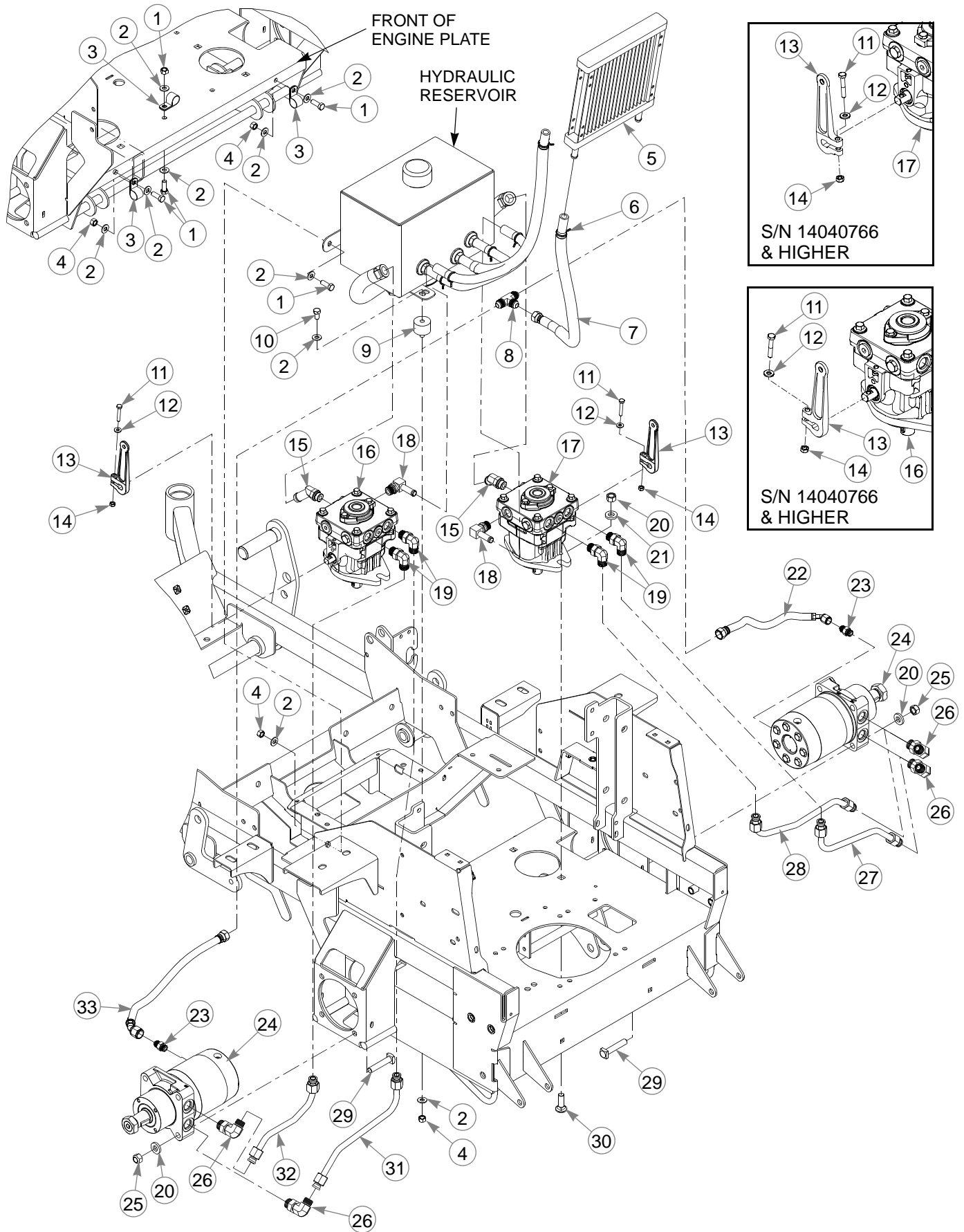

Hydraulic System

INDEX NO.	PART NO.	QTY.	DESCRIPTION
1	036244	5	CS .375-16 X 1.00 HX G5
2	767954	12	FW .379 X .813 X .063
3	043570	3	LOOP CLAMP
4	054502	6	NT .375-16 HX G5 ZNY
5	601356	1	OIL COOLER
6	601001	1	SPRING CLAMP
7	603815	1	CASE-COOLER HOSE
8	603820	1	FTG, 8MJIC TEE
9	601571	1	VIBRATION MOUNT
10	056069	1	CS .375-16 X .625 HX G5
11	008581	2	CS .250-20 X 1.50 HX G5 (S/N 14040766 & HIGHER)
	704163	2	CS .250-20 X 2.00 HX G5 Z (S/N PRIOR TO 14040766)
12	768515	2	FW .281 X .625 X .066 (S/N 14040766 & HIGHER)
	768515	4	FW .281 X .625 X .066 (S/N PRIOR TO 14040766)
13	604831	2	PUMP ARM (S/N 14040766 & HIGHER)
	115532	2	PUMP ARM (S/N PRIOR TO 14040766)
14	068551	2	NT .250-20 HX ZY NL
15	744854	2	O-RING TUBE ADAPTER 45
16	603709	1	LS PUMP
17	603710	1	RS PUMP
	784983	1	SEAL KIT, PW PUMPS (NOT SHOWN)
18	784082	1	FTG, 8 BEADED TUBE
19	781542	4	FTG, 90°-8MORB/-8MORFS
20	008193	4	NT .500-13 HX G5 ZNYC
21	767962	12	FW .531 X 1.063 X .175
22	603814	1	RS MOTOR CASE DRAIN HOSE
23	779132	2	FTG, -6MORB/-6MJIC STR
24	603715	2	MOTOR
25	023317	8	NT .500-13 UNT LK G8 ZN
26	781526	4	FTG, 90°-10 MORB/-8 MORFS
27	604332	1	TUBE, RP-BM RT LOOP
28	604333	1	TUBE, LP-TM RT LOOP
29	602256	8	CS .500-13 X 2.50 SQ G5
30	028274	4	CB .500-13 X 1.50 FULL
31	604335	1	TUBE, RP-BM LT LOOP
32	604334	1	TUBE, LP-TM LT LOOP
33	603813	1	LS MOTOR CASE DRAIN HOSE

NOTES:

Hydraulic Reservoir

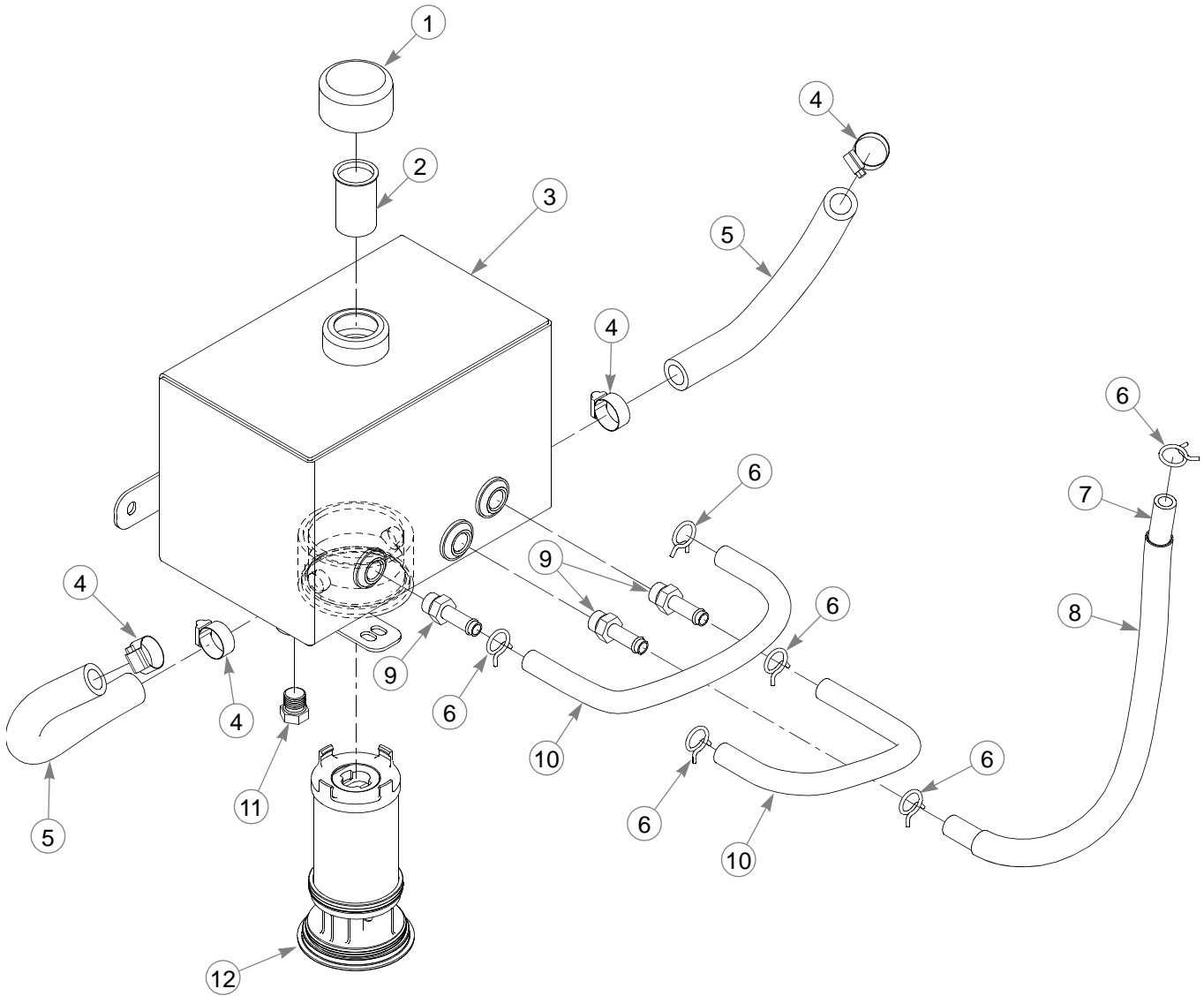

Hydraulic Reservoir

INDEX NO.	PART NO.	QTY.	DESCRIPTION
1	032763	1	BREATHER CAP
2	032771	1	STRAINER
3	604474	1	HYDRAULIC RESERVOIR
4	700484	4	HOSE CLAMP
5	603045	2	PUMP SUCTION HOSE
6	601001	7	SPRING CLAMP
7	603819	1	COOLER-RES HOSE
8	604492	2	PROTECTIVE HOSE SLEEVE
9	601523	3	FTG, -8MORB/-8BT STR
10	603767	2	PUMP RETURN HOSE
11	781658	1	FTG, -8 MORB HEX PLUG
12	602768X	1	HYDRAULIC FILTER

NOTES:

Hydraulic Motor Service Parts

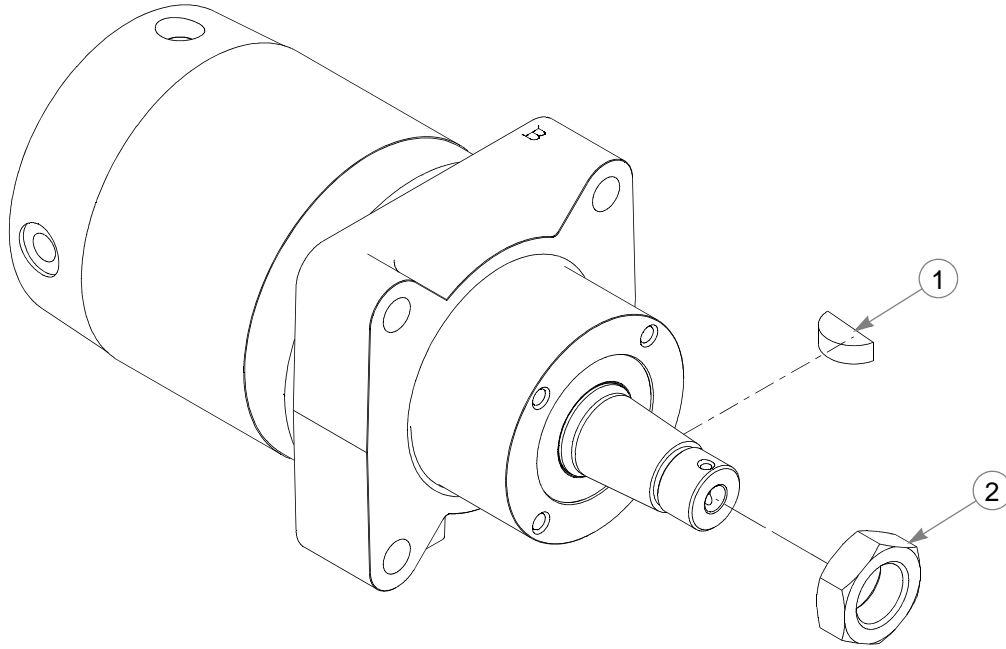

INDEX NO.	PART NO.	QTY.	DESCRIPTION
1	064337	1	WOODRUFF KEY
2	065516	1	CASTLE NUT
3	748806	1	SEAL KIT (NOT SHOWN)

NOTES:

This page intentionally left blank.

Oil Cooler Mount

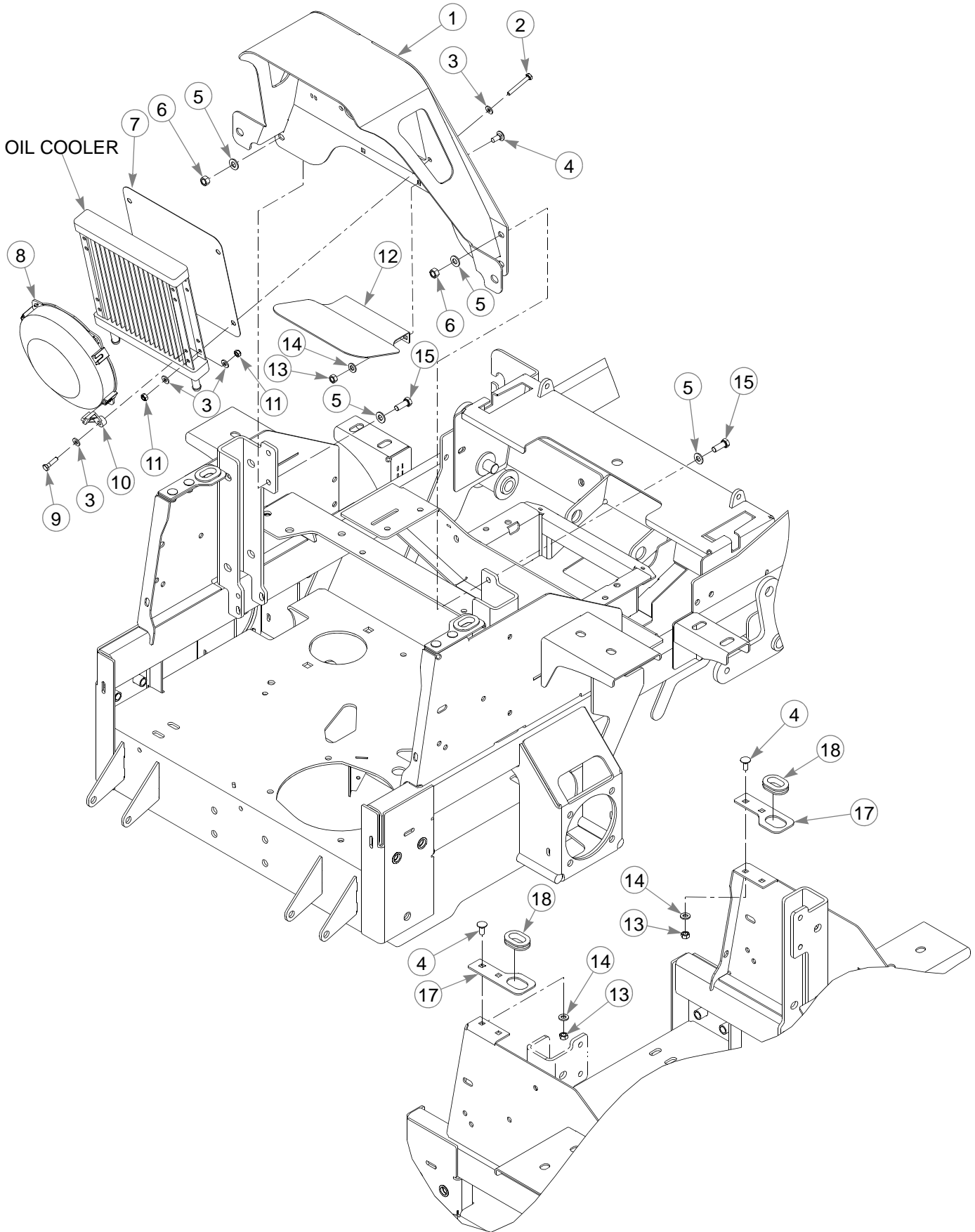

Oil Cooler Mount

INDEX NO.	PART NO.	QTY.	DESCRIPTION
1	117196	1	OIL COOLER MOUNT
2	704163	4	CS .250-20 X 2.00 HX G5 Z
3	768515	16	FW .281 X .625 X .066
4	016253	6	CB .312-18 X .75 FUL ZN
5	767954	8	FW .379 X .813 X .063
6	054502	4	NT .375-16 HX G5 ZNY
7	109401	1	OIL COOLER SCREEN
8	601357	1	8" ELECTRIC FAN
9	056077	4	CS .250-20 X 1.00 HX G5
10	601538	4	ELECTRIC FAN FOOT
11	068551	8	NT .250-20 HX ZY NL
12	115794	1	AIR DEFLECTOR
13	034272	6	NT .312-18 HX G5
14	768523	6	FW .343 X .687 X .051/.080H
15	036244	4	CS .375-16 X 1.00 HX G5
16	000430	5	WIRE TIE (NOT SHOWN)
17	117404	2	FUEL LINE BRACKET
18	706531	2	GM 1.12 X 1.75 X 1.37 X .12

NOTES:

Pump Drive

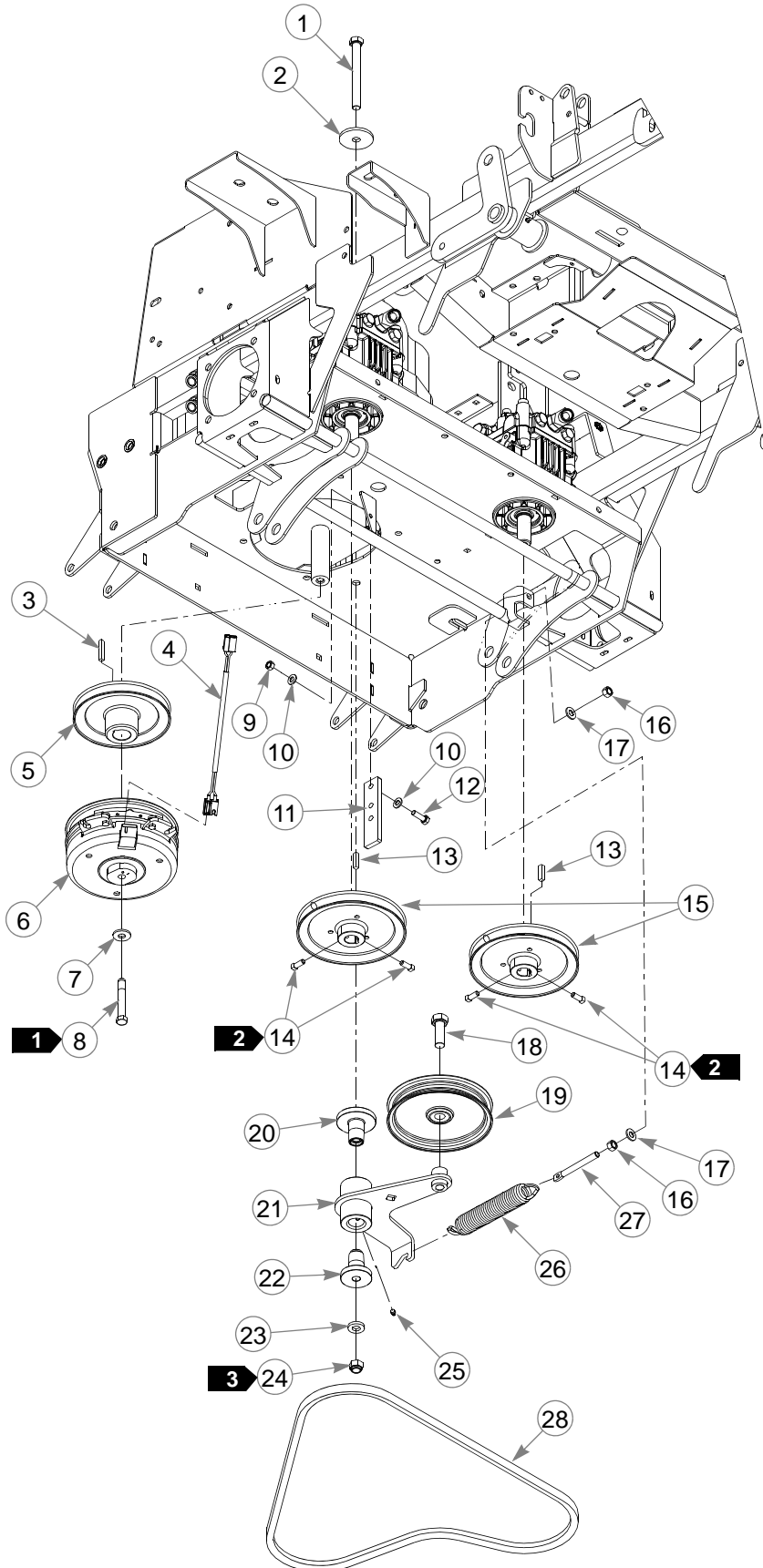

Pump Drive

INDEX NO.	PART NO.	QTY.	DESCRIPTION
1	051151	1	CS .500-13 X 5.00 HX G5
2	344267	1	FW .510 X 2.15 X .187 SPL
3	212076	1	KEY 1/4 SQ X 1.50 LG
4	791251	1	CLUTCH HARNESS PIGTAIL
5	603734	1	PULLEY 6.67 OP X 1.125 SHFT
6	601278K	1	CLUTCH KIT
7	602680	1	FW .453 X 1.12 X .119 HRD
8	785048	1	CS .437-20 X 3.00 HX G5 P85
9	034272	2	NT .312-18 HX G5
10	768523	4	FW .343 X .687 X .051/.080H
11	113347	1	CLUTCH ANCHOR
12	036236	2	CS .312-18 X 1.00 HX G5
13	210146	2	KEY 1/4 SQ X 1.12 LONG
14	083196	4	SS .312-18 X .75 SQ-HD
15	602754	2	PULLEY 7.35 OP X .875 SHFT
16	054502	2	NT .375-16 HX G5 ZNY
17	767954	2	FW .379 X .813 X .063
18	025007	1	CS .625-11 X 1.75 HX G5
19	603783	1	6" IDLER PULLEY
20	602880	1	IDLER PIVOT BUSHING
21	115536	1	TENSIONER
22	602879	1	IDLER PIVOT BUSHING
23	767962	1	FW .531 X 1.063 X .175
24	781567	1	NT .500-13 HX G8 ZY NL
25	015495	1	GREASE FITTING STRAIGHT
26	601016	1	IDLER SPRING
27	601486	1	EB, .375-16 X 3.00 FULL THD
28	604208	1	BELT, 64.89" B B-SECTION

NOTES:

1. Torque to 45–48 ft-lbs. Replace (no not reuse) the cap screw if it's removed or loosened. Use only hand tools to install this fastener.
2. Torque to 12–15 ft-lbs.
3. Torque to 71–75 ft-lbs. The tensioner should pivot freely.

Steering—S/N 13034312 & Higher

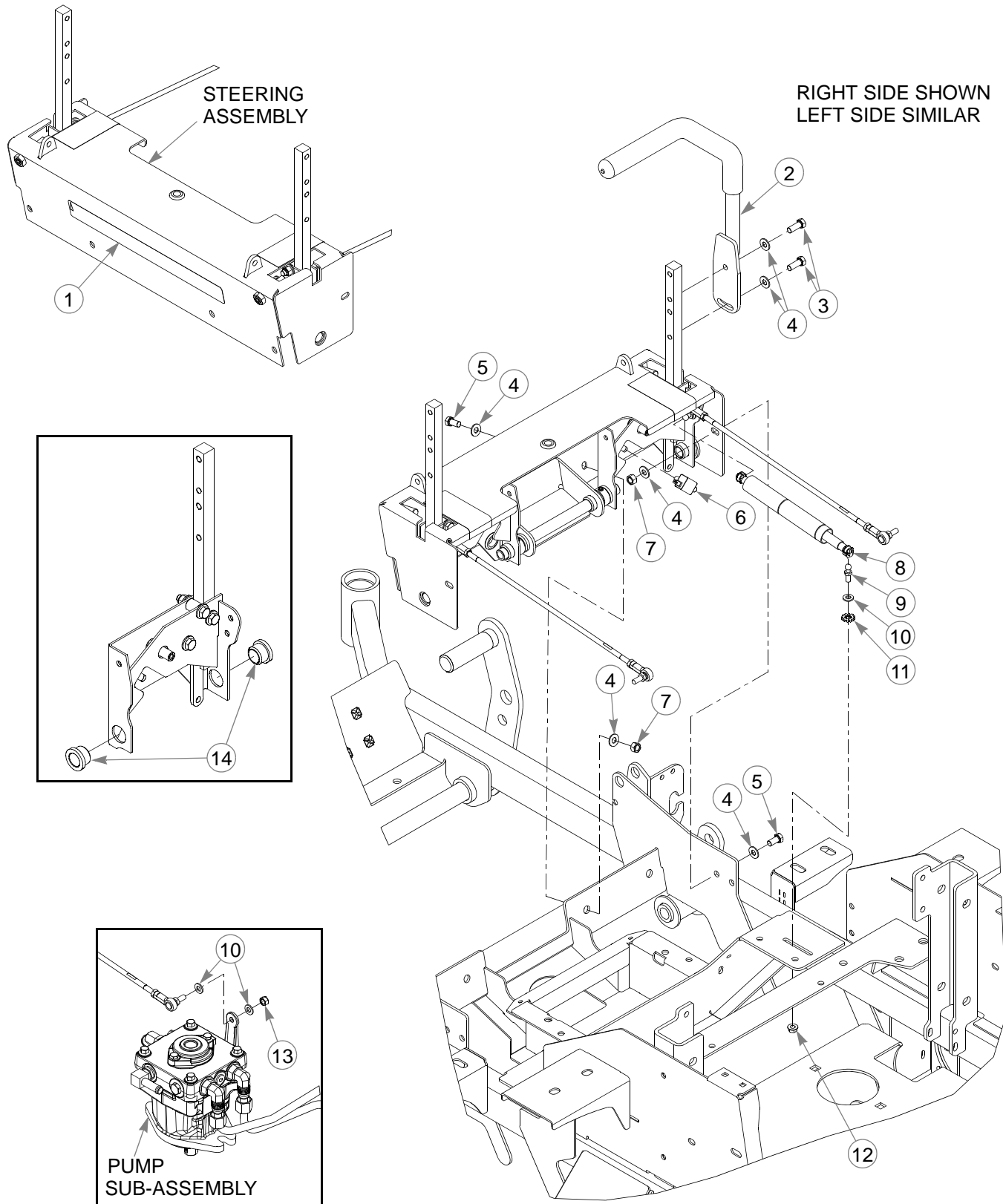

Steering—S/N 13034312 & Higher

INDEX NO.	PART NO.	QTY.	DESCRIPTION
1	605670	1	SUPER Z DECAL
2	109839	2	HANDLE (WITH GRIP)
	781260	2	GRIP
3	036244	4	CS .375-16 X 1.00 HX G5
4	767954	16	FW .379 X .813 X .063
5	055822	6	CS .375-16 X .75 HX G5
6	601087	2	SWITCH
7	054502	6	NT .375-16 HX G5 ZNY
8	795351	2	DAMPER
9	781922	2	BALL STUD
10	768523	6	FW .343 X .687 X .051/.080H
11	029876	2	LW .325 INT-EXT TOOTH
12	016832	2	NT .312-18 HX FLK ZNYC
13	023655	2	NT .312-24 HX NL G5
14	781153	4	BUSHING

NOTES:

Steering—S/N Prior to 13034312

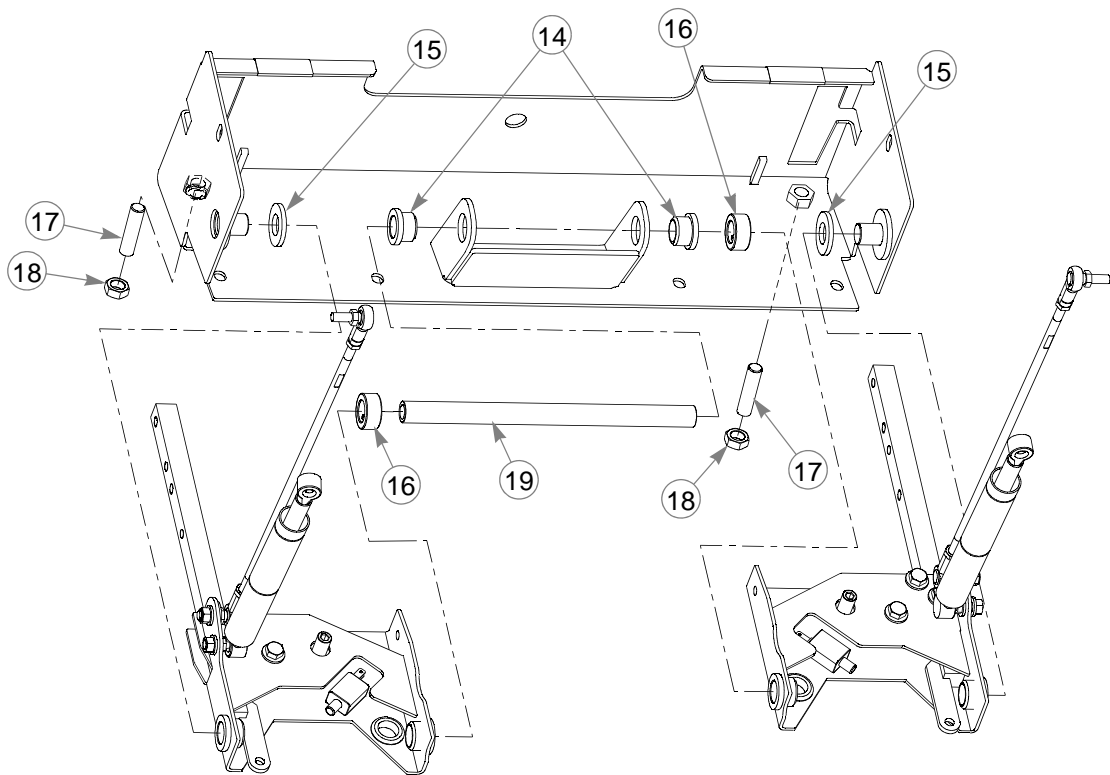
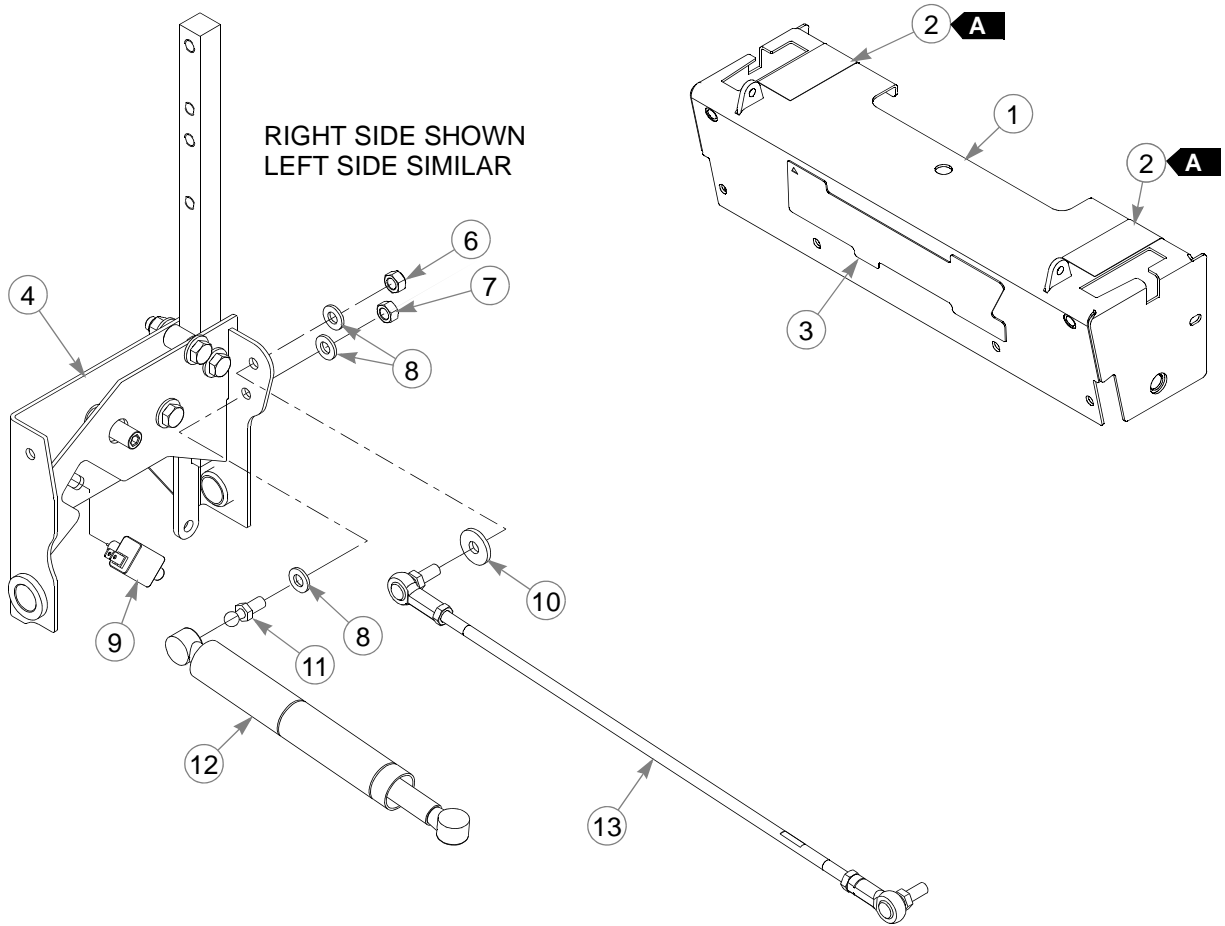

Steering—S/N Prior to 13034312

INDEX NO.	PART NO.	QTY.	DESCRIPTION
1	550818	1	STEERING COVER (WITH DECALS)
2	722199	11"	WEAR TAPE
3	603227	1	SUPER Z DECAL
4	604295	1	RS STEERING BOX SUB-ASSEMBLY
5	604296	1	LS STEERING BOX SUB-ASSEMBLY (NOT SHOWN)
6	023655	4	NT .312-24 HX NL G5
7	034272	2	NT .312-18 HX G5
8	768523	12	FW .343 X .687 X .051/.080H
9	601087	2	SWITCH
10	712927	2	FW .344 X 1.00 X .12 HRD Z
11	781922	4	BALL STUD
12	795351	2	DAMPER
13	781286	2	PUMP ROD ADJUSTER
14	781153	2	BUSHING
15	603078	2	FW .750 X 1.50 X .156 ZN
16	784439	2	LOCK COLLAR .757 ID
17	797738	2	SS .500-13 X 2.00 SH ZY
18	053199	2	NT .500-13 HX JAM ZNYC
19	113007	1	STEER PIVOT TUBE

NOTES:

WEAR TAPE LENGTH	
	5.5" ± 0.3"

Steering—S/N Prior to 13034312

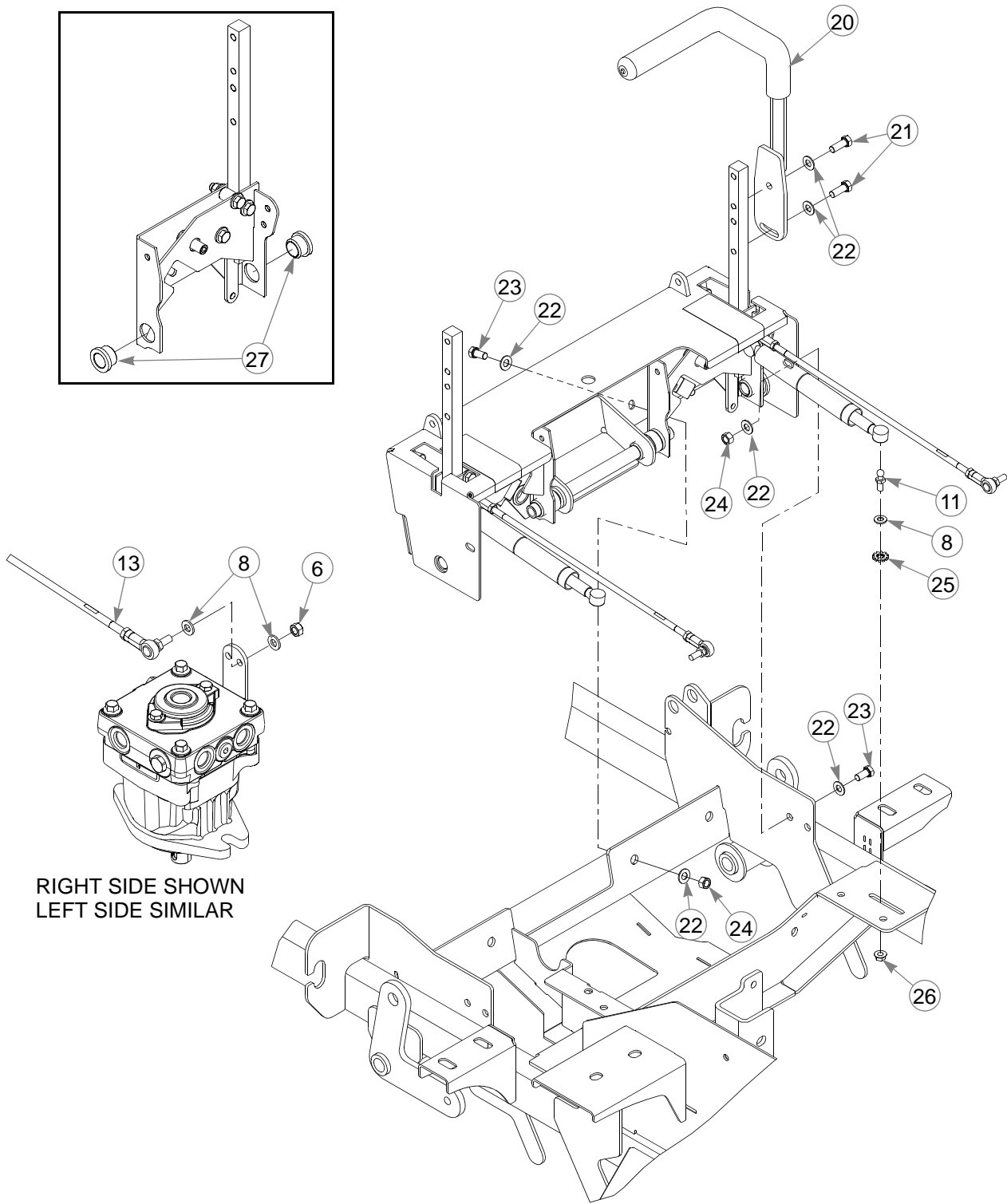

RIGHT SIDE SHOWN
LEFT SIDE SIMILAR

Steering—S/N Prior to 13034312

INDEX NO.	PART NO.	QTY.	DESCRIPTION
20	109839	2	HANDLE (WITH GRIP)
	781260	1	STEERING BAR GRIP
21	036244	4	CS .375-16 X 1.00 HX G5
22	767954	16	FW .379 X .813 X .063
23	055822	6	CS .375-16 X .75 HX G5
24	054502	6	NT .375-16 HX G5 ZNY
25	029876	2	LW .325 INT-EXT TOOTH
26	016832	2	NT .312-18 HX FLK ZNYC
27	781153	4	BUSHING

NOTES:

Steering Assembly

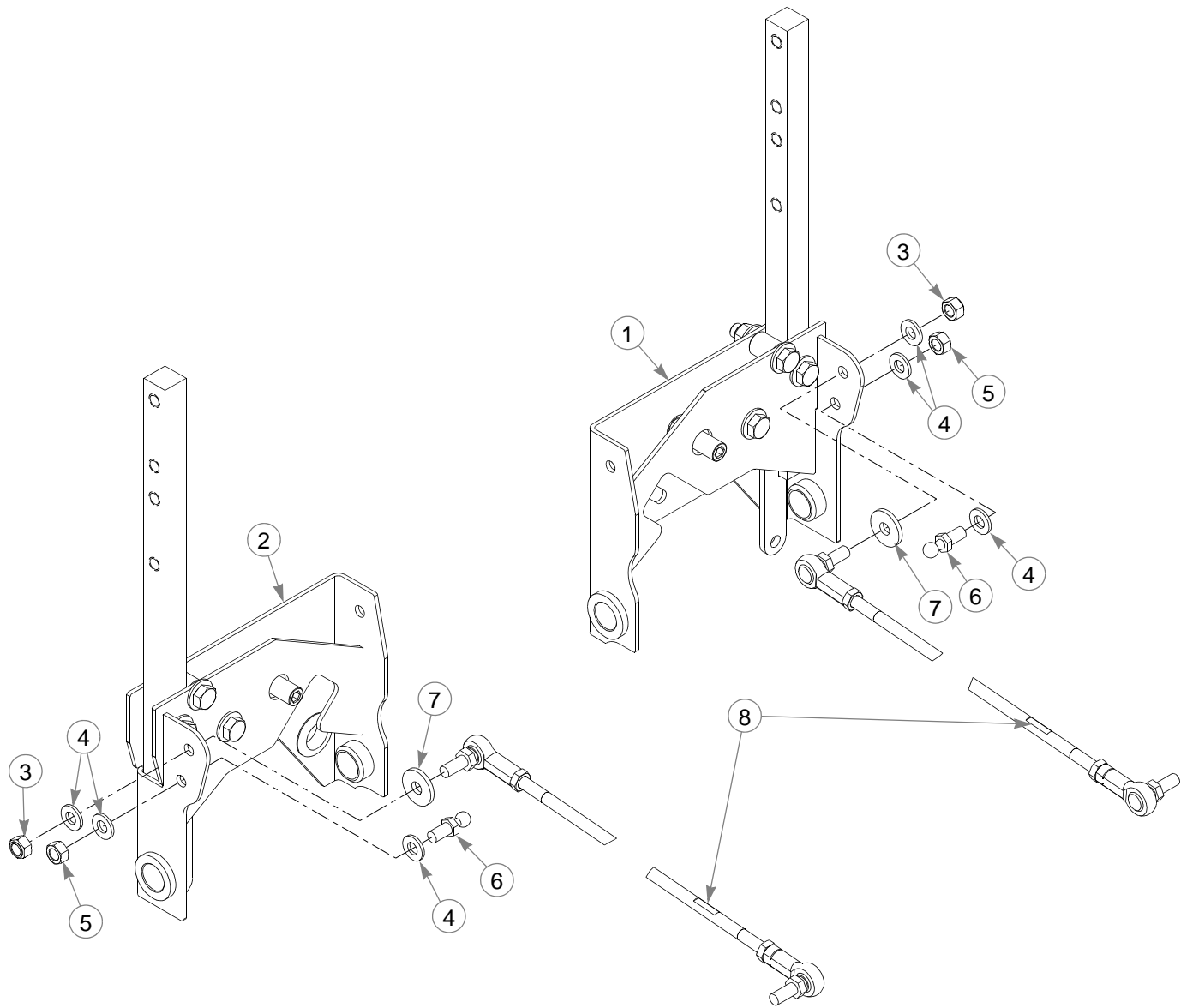

Steering Assembly

INDEX NO.	PART NO.	QTY.	DESCRIPTION
1	604295	1	RS STEERING BOX ASSEMBLY
2	604296	1	LS STEERING BOX ASSEMBLY
3	023655	2	NT .312-24 HX G5 NL
4	768523	6	FW .343 X .687 X .051/.080H
5	034272	2	NT .312-18 HX G5
6	781922	2	BALL STUD
7	712927	2	FW .344 X 1.00 X .12 HRD Z
8	781286	2	PUMP ROD ADJUSTER

NOTES:

Steering Cover Assembly

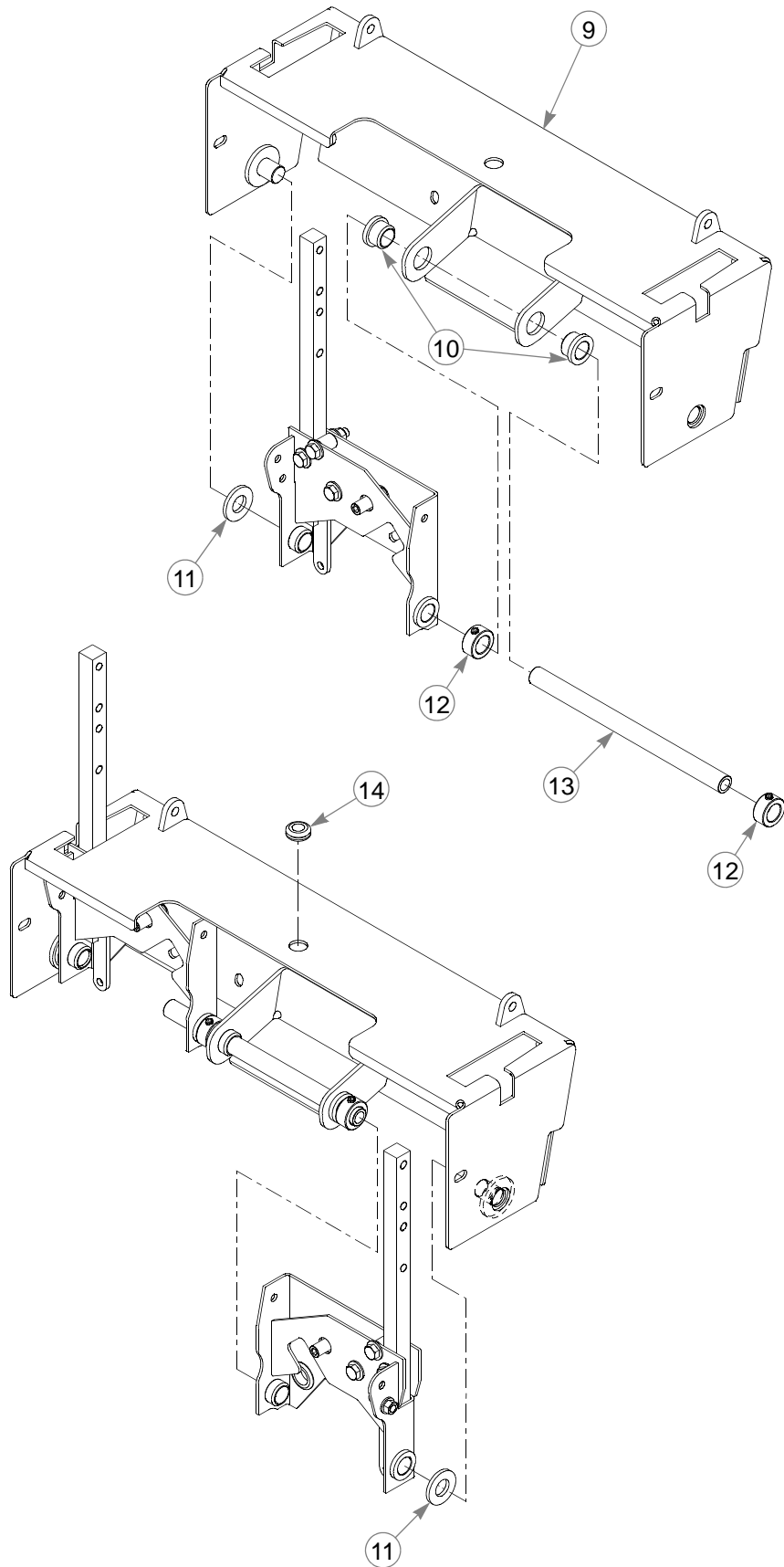

Steering Cover Assembly

INDEX NO.	PART NO.	QTY.	DESCRIPTION
9	550818	1	STEERING COVER (WITH DECAL)
10	781153	2	BUSHING
11	603078	2	FW .750 X 1.50 X .156 ZN
12	784439	2	LOCK COLLAR .757 ID
13	113007	1	STEER PIVOT TUBE
14	080358	1	GM .50 X 1.00 X .75 X .12

NOTES:

Steering Cover Assembly

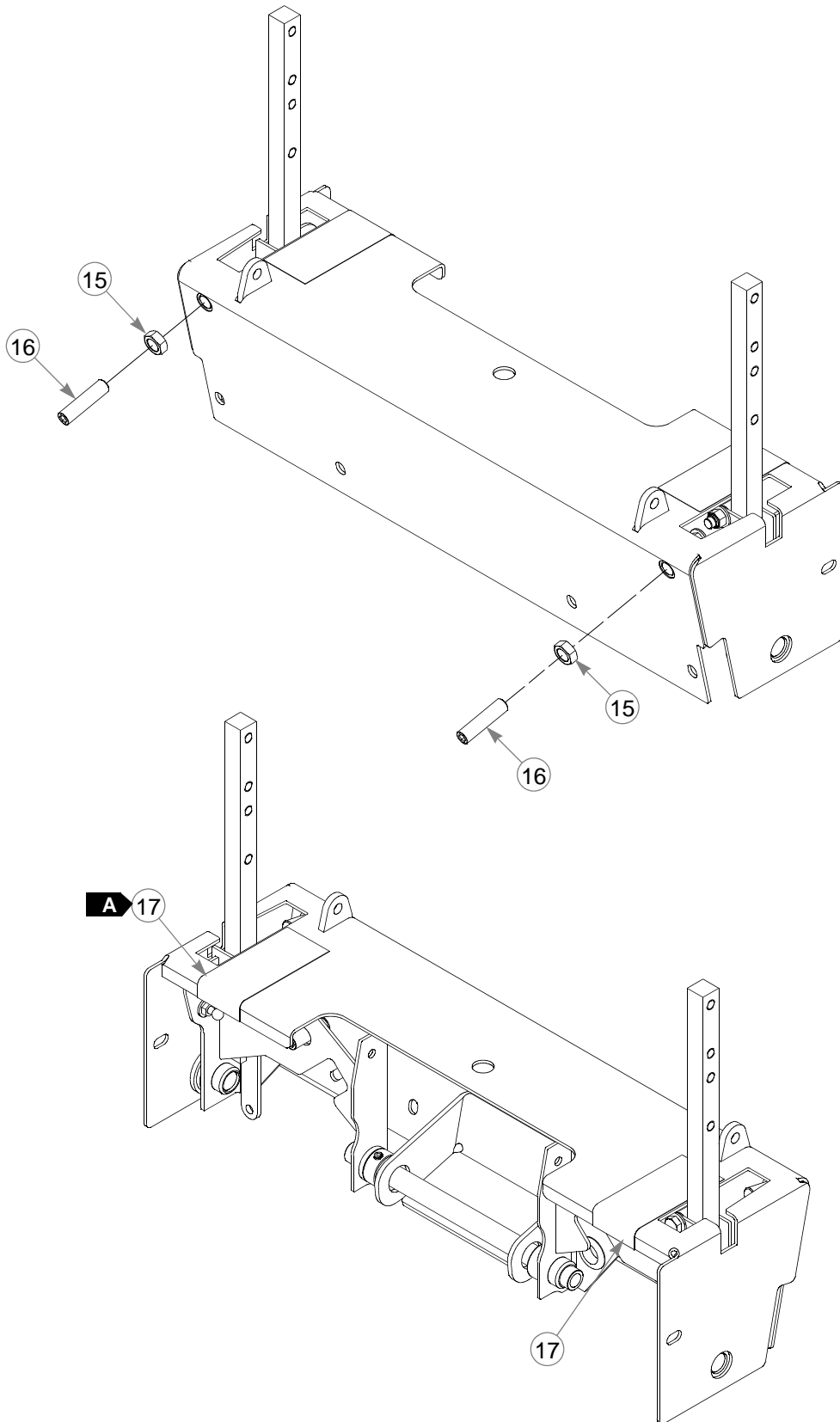

Steering Cover Assembly

INDEX NO.	PART NO.	QTY.	DESCRIPTION
15	053199	2	NT .500-13 HX JAM ZNYC
16	797738	2	SS .500-13 X 2.00 SH
17	722199	11"	WEAR TAPE

NOTES:

WEAR TAPE LENGTH	
	5.5" ± 0.3"

Brake

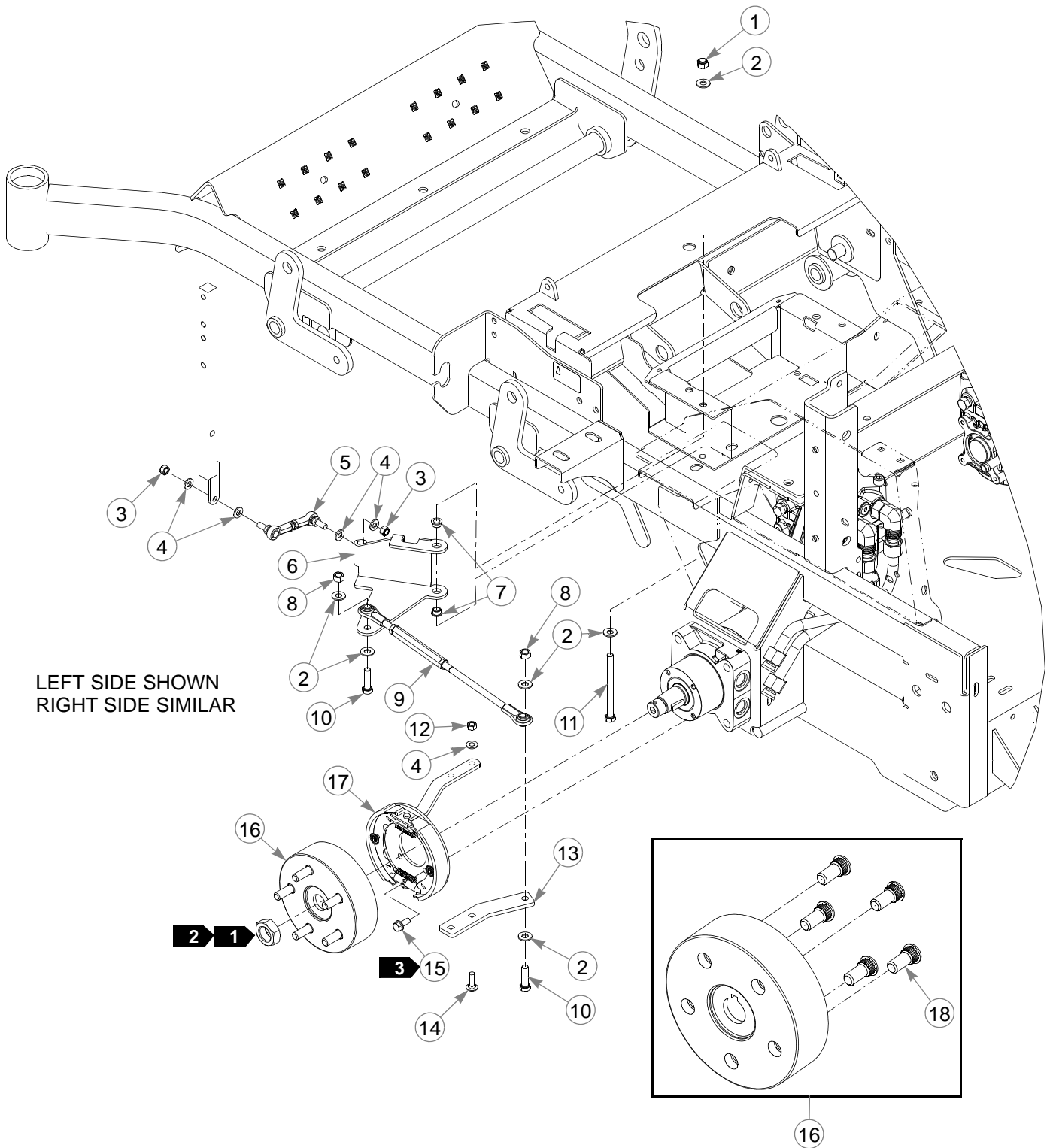

Brake

INDEX NO.	PART NO.	QTY.	DESCRIPTION
1	086660	2	NT .375-16 HX ZY NL
2	767954	12	FW .379 X .813 X .063
3	023655	4	NT .312-24 HX NL G5
4	768523	12	FW .343 X .687 X .051/.080H
5	781583	2	BRAKE ROD ASSEMBLY
6	112907	1	LS BRAKE BELLCRANK
	112906	1	RS BRAKE BELLCRANK (NOT SHOWN)
7	765339	4	BUSHING
8	054502	4	NT .375-16 HX G5 ZNY
9	350397	2	BRAKE LINK TURNBUCKLE
10	005116	4	CS .375-16 X 1.375 HX G5
11	052514	2	CS .375-16 X 4.50 HX G5
12	034272	4	NT .312-18 HX G5
13	111309	2	BRAKE ARM
14	037887	4	CB .312-18 X 1.00 FULL ZN
15	604461	8	CS .312-18 X .75 HX G8 FLK
16	602384	2	HUB ASSEMBLY (WITH STUDS)
17	602383	2	BRAKE ASSEMBLY
18	601085	5	WHEEL STUD LUG 1/2-20

NOTES:

1. Included with the wheel motor.
2. Torque to 220–240 ft-lbs.
3. Torque to 27 ft-lbs.

Section 4

Wheel & Tire	4-2
Front Wheel Assembly.	4-4
Drive Wheel Breakdown	4-6

Wheel & Tire

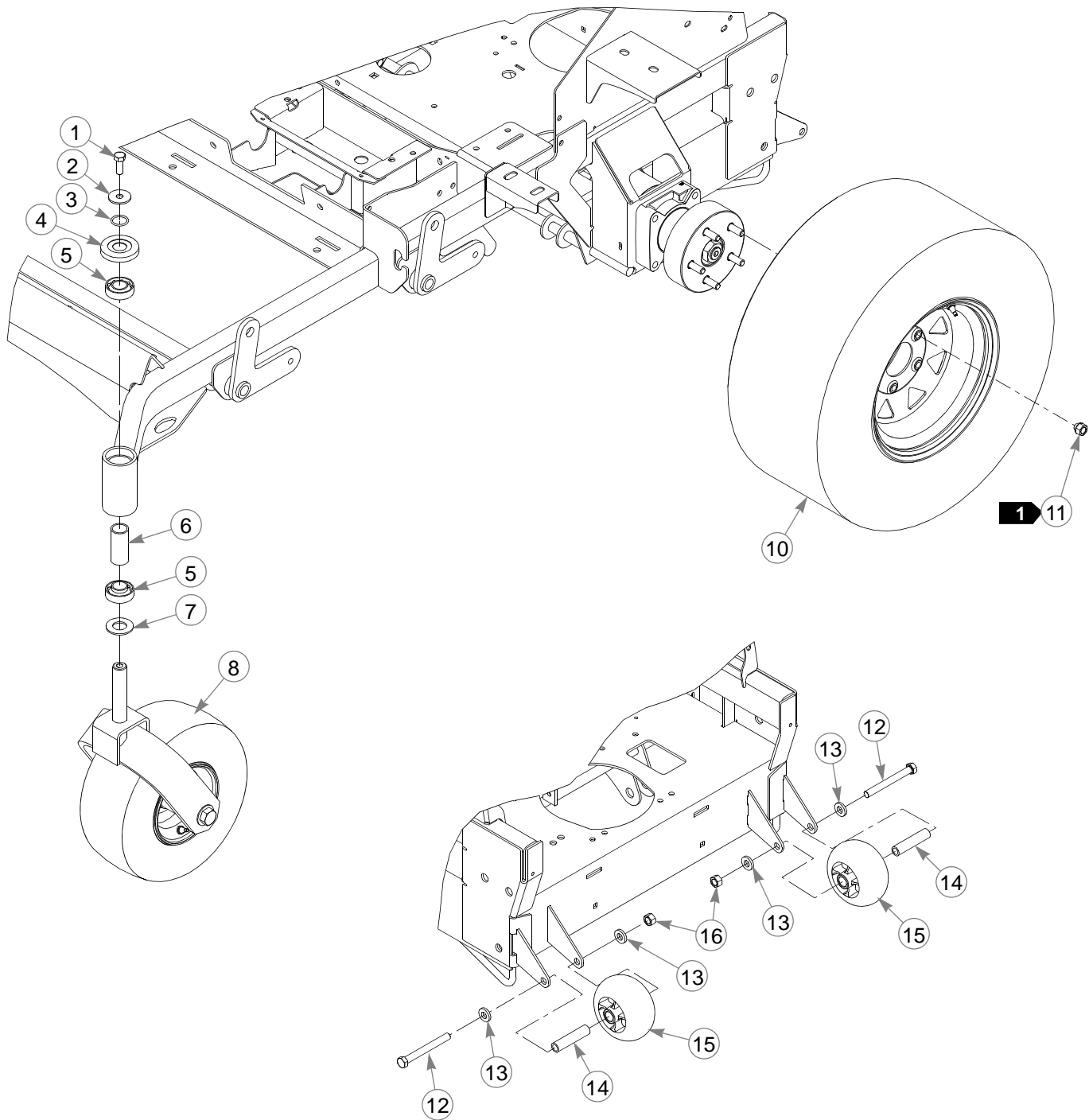

Wheel & Tire

INDEX NO.	PART NO.	QTY.	DESCRIPTION
1	705954	2	CS .500-13 X 1.25 HX G5
2	798603	2	FW .515 X 1.65 X .125 HD ZY
3	601375	2	O-RING, SAE-14
4	603153	2	DUST CAP
5	784223	4	BEARING
6	387035	2	SPACER 1.07 X 1.312 X 2.79
7	603164	2	DISC BEARING
8	N/A	1	LS FRONT TIRE ASSEMBLY
9	N/A	1	RS FRONT TIRE ASSEMBLY (NOT SHOWN)
10	782078	2	TIRE/WHEEL ASSEMBLY 24 X 9.50 (54" MOWERS)
	601238	2	TIRE/WHEEL ASSEMBLY 24 X 12 X 12 (60" MOWERS)
	784058	2	TIRE/WHEEL ASSEMBLY 24 X 12 X 12 (66"/72" MOWERS)
11	061077	10	WHEEL NUT
12	068239	2	CS .500-13 X 4.50 HX G5
13	767962	4	FW .531 X 1.063 X .175
14	602345	2	SPACER 3.22
15	602263	2	PLASTIC WHEEL
16	008193	2	NT .500-13 HX G5 ZNYC

NOTES:

1. Torque to 65–75 ft-lbs.

Front Wheel Assembly

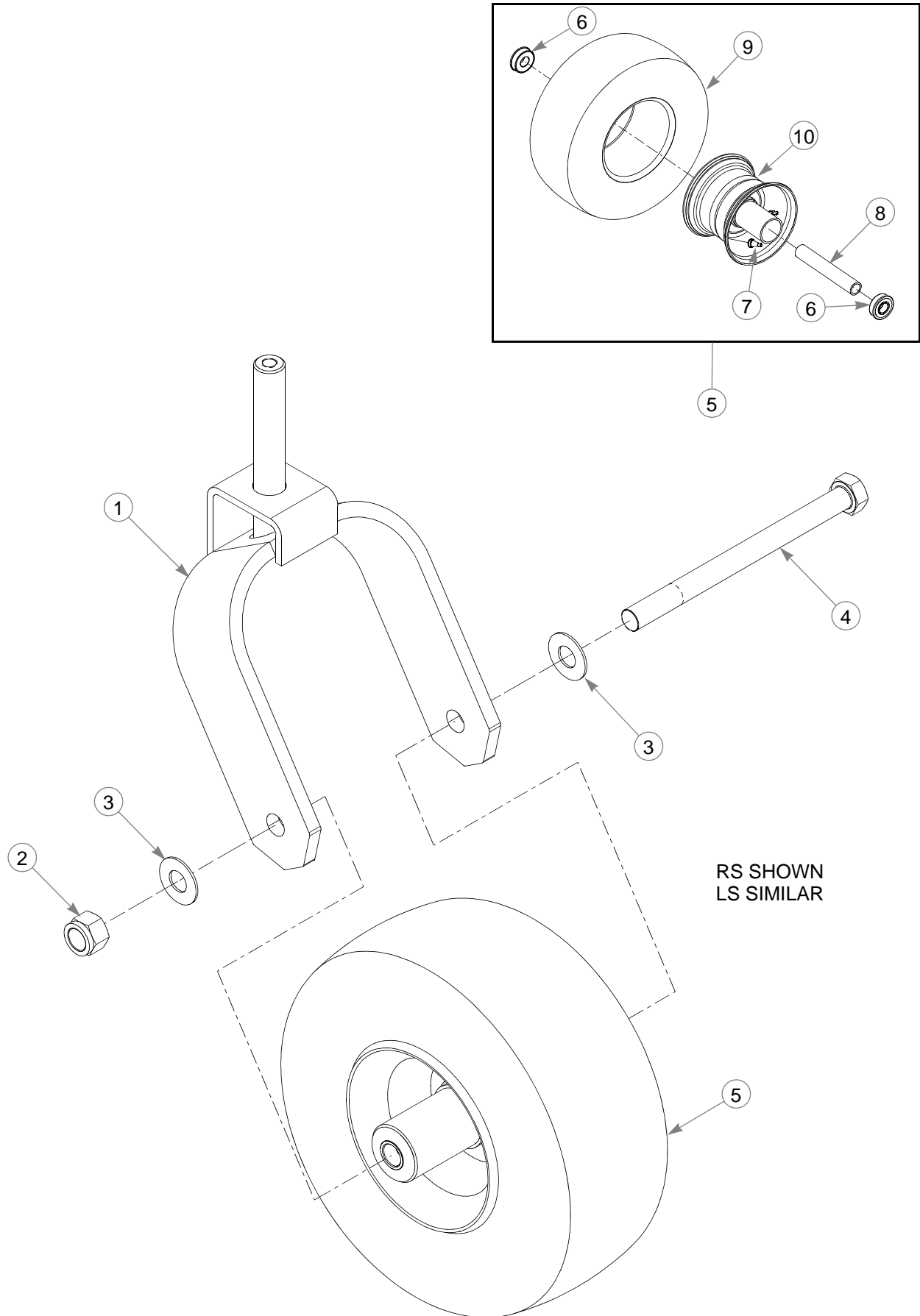

Front Wheel Assembly

INDEX NO.	PART NO.	QTY.	DESCRIPTION
1	116890	1	FORK, HEAVY DUTY
	113621	1	FORK
2	061101	1	NT .750-10 HX ZY NL
3	025296	2	FW .760 X 1.625 X .08 ZNYC
4	041475	1	CS .750-10 X 9.50 HX ZY
5	604898	1	TIRE/WHEEL ASSEMBLY 13 X 6.50 (SMOOTH)
	747782	1	TIRE/WHEEL ASSEMBLY 13 X 6.50 (RIBBED)
6	039677	2	BEARING
7	019521	1	VALVE STEM
8	782771	1	BEARING SPACER
9	604843	1	TIRE (SMOOTH)
	747741	1	TIRE (RIBBED)
10	747832	1	WHEEL

NOTES:

Drive Wheel Breakdown

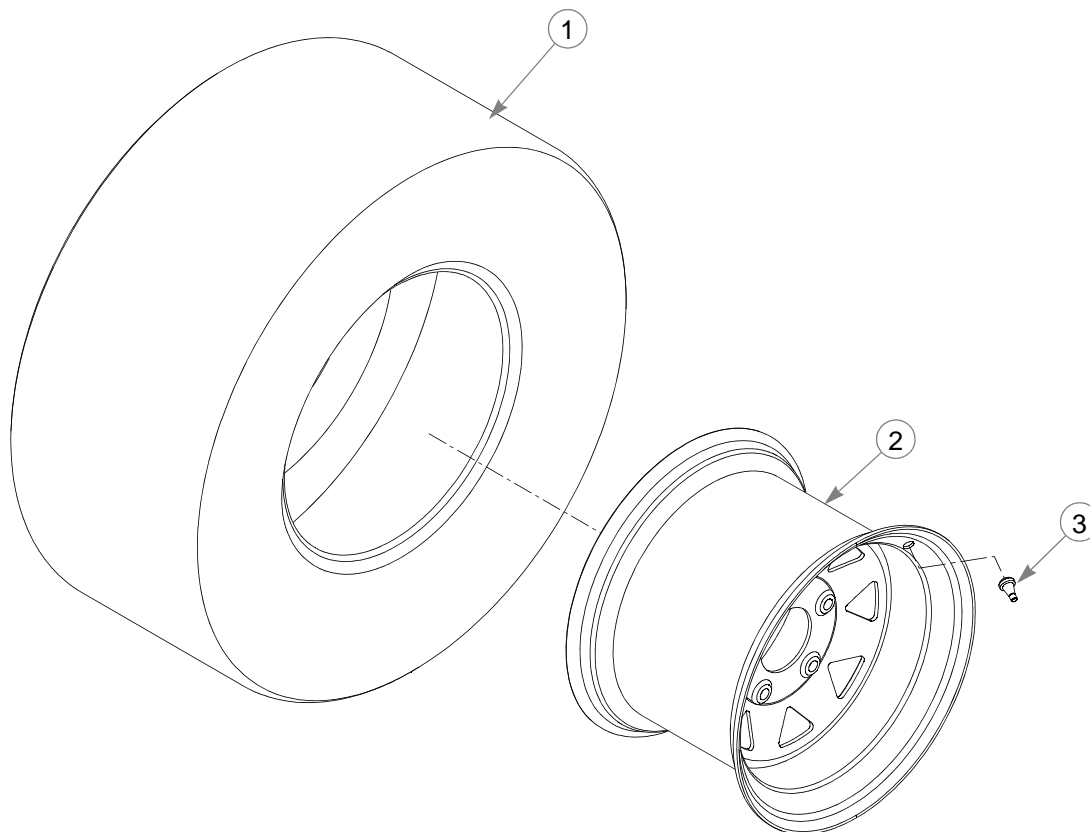

782078 TIRE/WHEEL ASSEMBLY (54" MOWER)

INDEX NO.	PART NO.	QTY.	DESCRIPTION
1	782284	1	TIRE 24 X 9.50-12
2	782086	1	WHEEL 12 X 7
3	019521	1	VALVE STEM

601238 TIRE/WHEEL ASSEMBLY (60" MOWER)

INDEX NO.	PART NO.	QTY.	DESCRIPTION
1	781245	1	TIRE 24 X 12-12
2	796250	1	WHEEL 12 X 8.50
3	019521	1	VALVE STEM

784058 TIRE/WHEEL ASSEMBLY (66"/72" MOWERS)

INDEX NO.	PART NO.	QTY	DESCRIPTION
1	781245	1	TIRE 24 X 12-12
2	784066	1	WHEEL 12 X 8.50
3	019521	1	VALVE STEM

NOTES:

Section 5

Engine, Briggs & Stratton EFI	5-2
Engine Service Parts, Briggs & Stratton EFI	5-4
Engine, Kawasaki FX801V	5-6
Engine, Kawasaki FX850V	5-10
Engine Service Parts, Kawasaki FX801V, FX850V	5-13
Engine, Kawasaki FX1000V	5-14
Engine, Kawasaki FX1000V DFI	5-16
Engine Service Parts, Kawasaki FX1000V	5-18
Fuel System, Briggs & Stratton—With Carbon Canister	5-20
Vapor System, Briggs & Stratton—With Carbon Canister	5-22
Fuel System, Kaw/Briggs & Stratton—W/O Carbon Canister	5-24
Fuel System, Kawasaki—With Carbon Canister	5-26
Vapor System, Kawasaki—With Carbon Canister	5-28
Fuel System, Kawasaki—DFI	5-30
Fuel Tank Service Parts—S/N 14044000 & Higher	5-32
Fuel Tank Service Parts—S/N Prior to 14044000	5-33

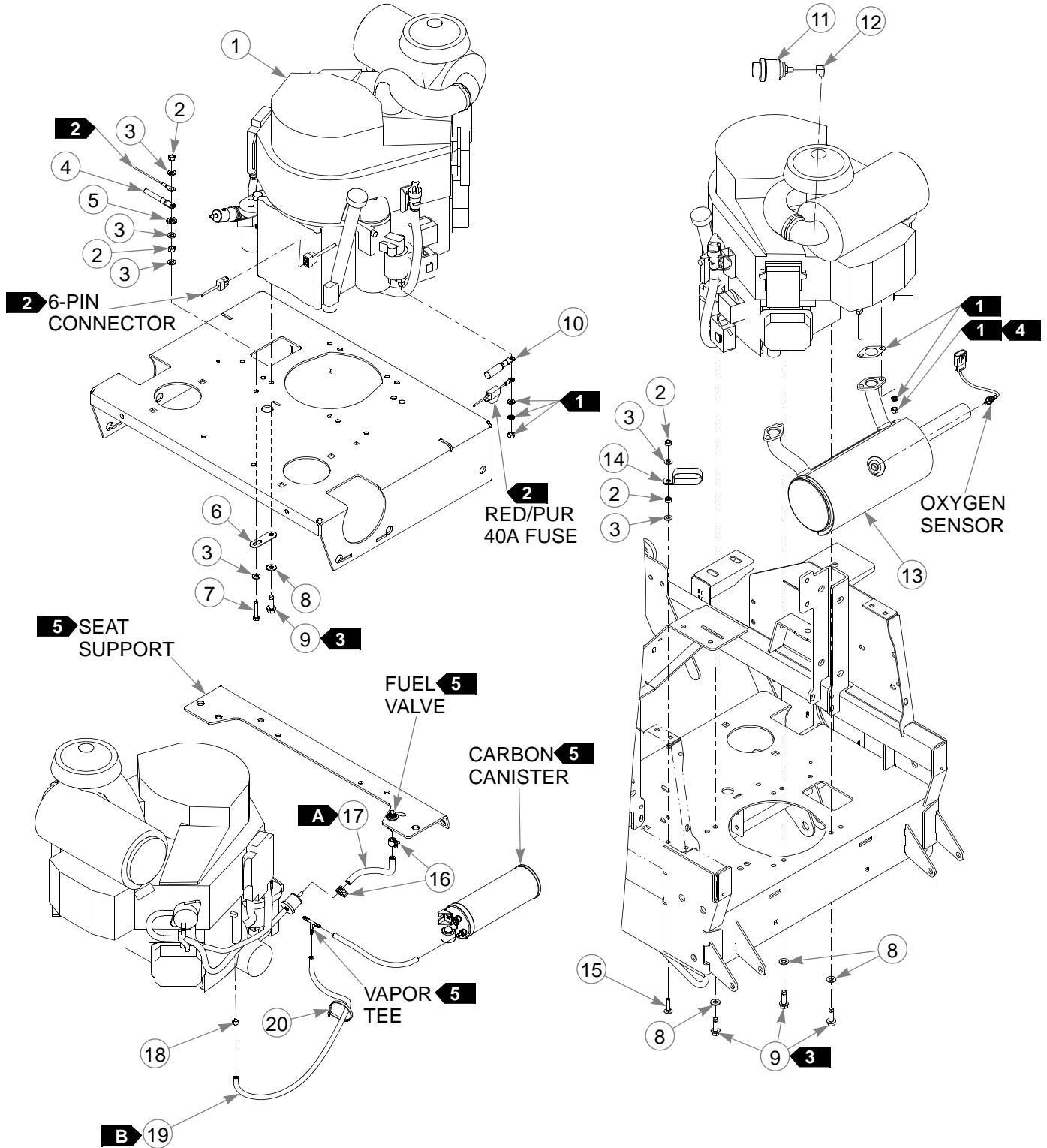

Engine, Briggs & Stratton EFI



Engine, Briggs & Stratton EFI

INDEX NO.	PART NO.	QTY.	DESCRIPTION
1	N/A	1	VANGUARD M49 ENGINE
2	034272	4	NT .312-18 HX G5
3	768523	6	FW .343 X .687 X .051/.080H
4	605155	1	NEGATIVE BATTERY CABLE
5	029876	1	LW .325 INT-EXT TOOTH
6	121771	1	GROUND STRAP
7	756270	1	CS .312-18 X 1.50 HX G5
8	767954	4	FW .379 X .813 X .063
9	605814	4	SC .375-16 X 1.25 FLG
10	604029	1	POSITIVE BATTERY CABLE
11	788943	1	AIR FILTER INDICATOR
12	601216	1	ELBOW STREET FITTING
13	605494	1	EFI MUFFLER
14	045088	1	HOSE CLAMP
15	602827	1	CB .312-18 X 1.25 ZNYC
16	000323	2	HOSE CLAMP
17	015818	4"	1/4" FUEL LINE
18	603112	1	CLAMP, 3/16"
19	603326	22"	3/16" VAPOR LINE
20	000331	4	WIRE TIE

NOTES:

FUEL & VAPOR LINE LENGTHS		
A 	4"	VALVE TO FILTER (FUEL)
B 	22"	TEE TO ENGINE (VAPOR)

1. Supplied with the engine.
2. Part of the wire harness.
3. Torque to 30 ft-lbs. Replace (do not reuse) the cap screw if it is removed or loosened.
4. Torque to 17.5 ft-lbs \pm 1.8 ft-lbs.
5. Part of the Fuel Assembly.

Engine Service Parts, Briggs & Stratton EFI

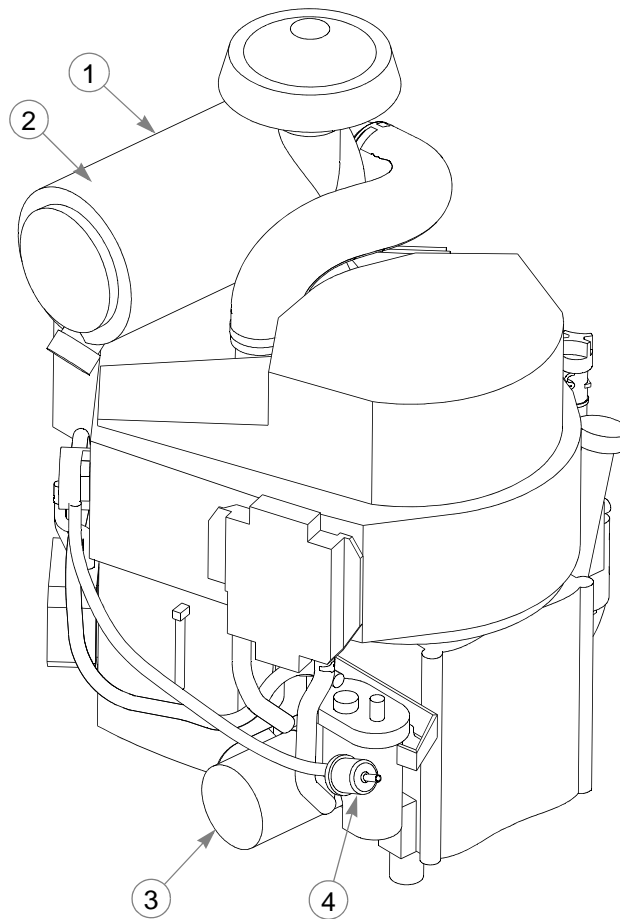

INDEX NO.	PART NO.	QTY.	DESCRIPTION
1	785261	1	MAIN AIR FILTER
2	785279	1	SAFETY AIR FILTER
3	603196	1	OIL FILTER
4	605763	1	IN-LINE FUEL FILTER

NOTES:

This page intentionally left blank.

Engine, Kawasaki FX801V

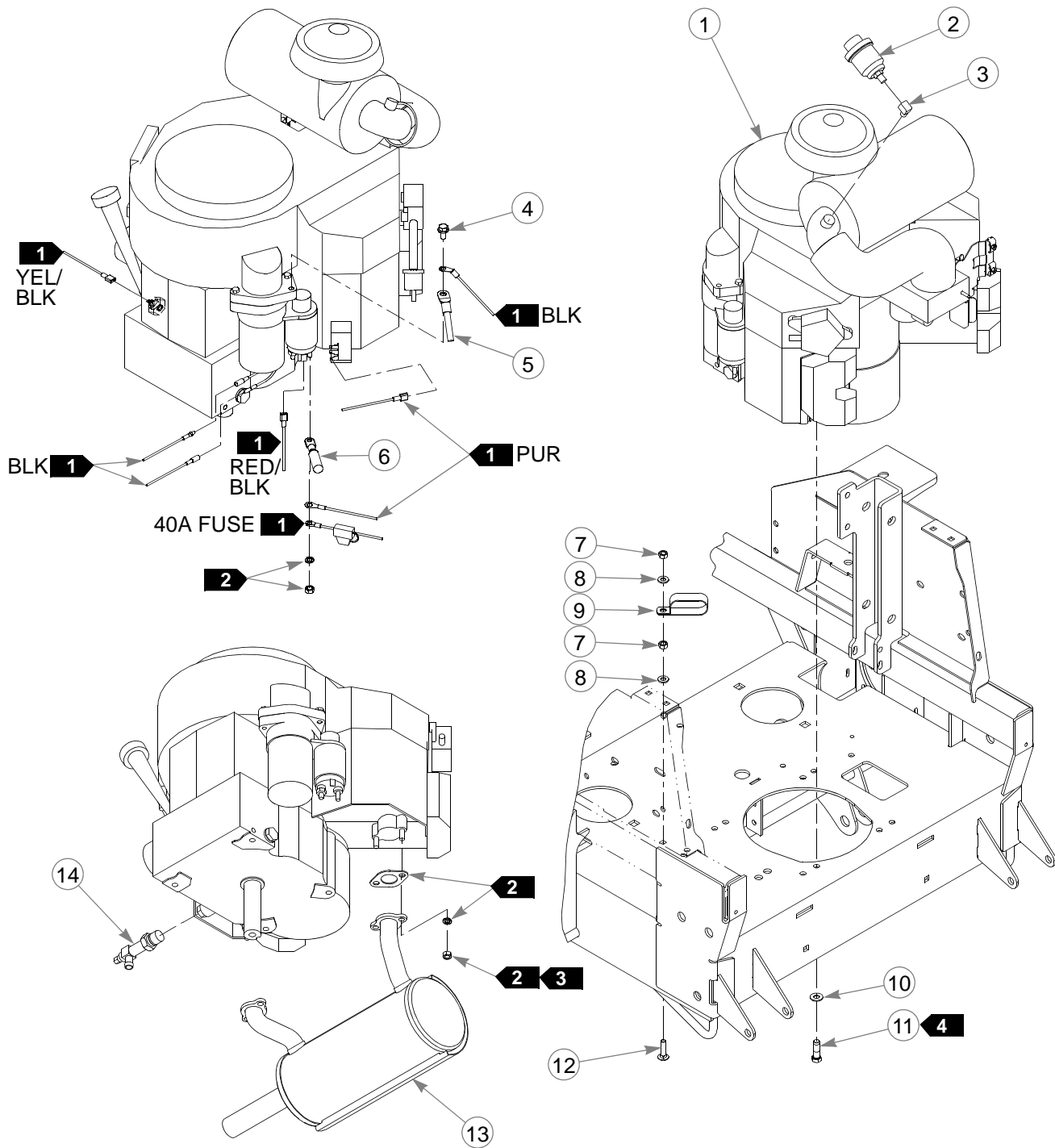

Engine, Kawasaki FX801V

INDEX NO.	PART NO.	QTY.	DESCRIPTION
1	N/A	1	KAWASAKI FX801V ENGINE
2	788943	1	AIR FILTER INDICATOR
3	601216	1	ELBOW STREET FITTING
4	720516	1	CS M8 X 1.25 X 16 HX FL 10.9
5	605155	1	NEGATIVE BATTERY CABLE
6	604029	1	POSITIVE BATTERY CABLE
7	034272	2	NT .312-18 HX G5
8	768523	5	FW .343 X .687 X .051/.080H
9	045088	1	HOSE CLAMP
10	767954	4	FW .379 X .813 X .063
11	602580	4	CS .375-16 X 1.25 HX G8 P85
12	602827	1	CB .312-18 X 1.25 ZNYC
13	603012	1	MUFFLER
14	796524	1	OIL DRAIN VALVE

NOTES:

1. Part of the wire harness.
2. Supplied with the engine.
3. Torque to 22 ft-lbs.
4. Torque to 12 ft-lbs plus 90° rotation of the cap screw head. Replace (do not reuse) the cap screw if it is removed or loosened. Use only hand tools to install this fastener.

Engine, Kawasaki FX801V

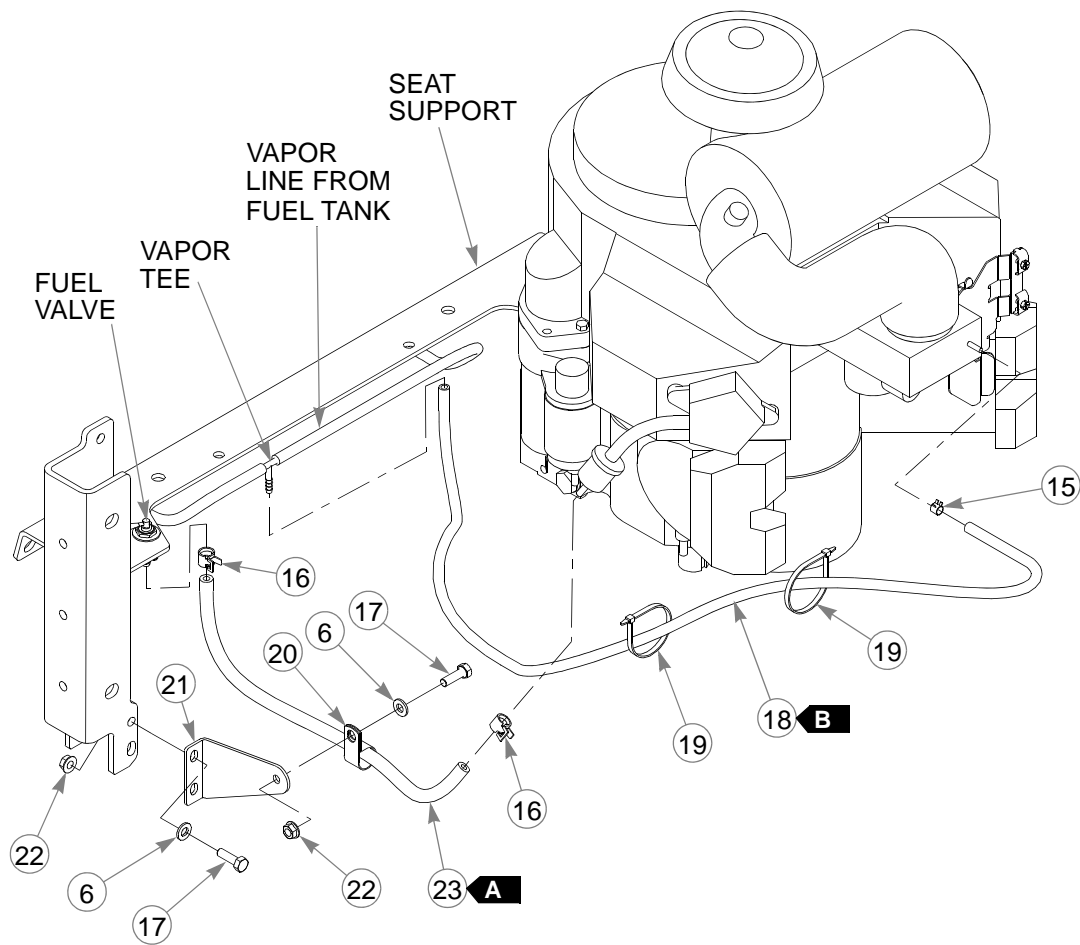

INDEX NO.	PART NO.	QTY.	DESCRIPTION
15	603112	1	CLAMP, 3/16"
16	000323	2	HOSE CLAMP
17	036236	3	CS .312-18 X 1.00 HX G5
18	603326	44"	3/16" VAPOR LINE
19	000331	4	WIRE TIE
20	043570	1	LOOP CLAMP
21	114578	1	BRACE
22	016832	3	NT .312-18 HX FLK ZNYC
23	015818	17"	1/4" FUEL LINE

NOTES:

FUEL & VAPOR LINE LENGTHS		
A	17"	VALVE TO ENGINE (FUEL)
B	44"	TEE TO ENGINE (VAPOR)

This page intentionally left blank.

Engine, Kawasaki FX850V

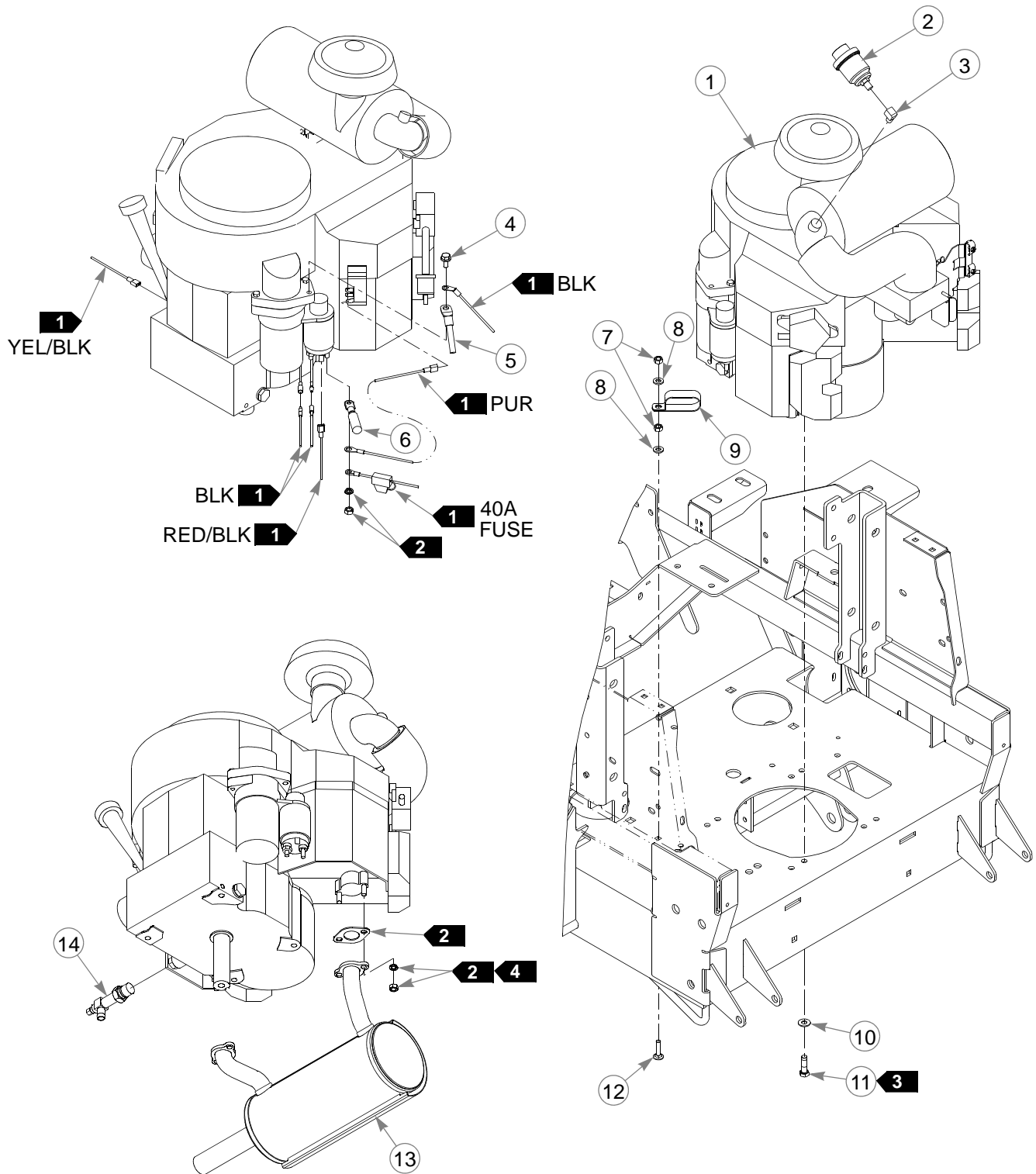

Engine, Kawasaki FX850V

INDEX NO.	PART NO.	QTY.	DESCRIPTION
1	N/A	1	KAWASAKI FX850V ENGINE
2	788943	1	AIR FILTER INDICATOR
3	601216	1	ELBOW STREET FITTING
4	720516	1	CS M8 X 1.25 X 16 HX FL 10.9
5	605155	1	NEGATIVE BATTERY CABLE
6	604029	1	POSITIVE BATTERY CABLE
7	034272	2	NT .312-18 HX G5
8	768523	5	FW .343 X .687 X .051/.080H
9	045088	1	HOSE CLAMP
10	767954	4	FW .379 X .813 X .063
11	602580	4	CS .375-16 X 1.25 HX G8 P85
12	602827	1	CB .312-18 X 1.25 ZNYC
13	603012	1	MUFFLER
14	796524	1	OIL DRAIN VALVE

NOTES:

1. Part of the wire harness.
2. Supplied with the engine.
3. Torque to 12 ft-lbs plus 90° rotation of the cap screw head. Replace (do not reuse) the cap screw if it is removed or loosened. Use only hand tools to install this fastener.
4. Torque to 22 ft-lbs.

Engine, Kawasaki FX850V

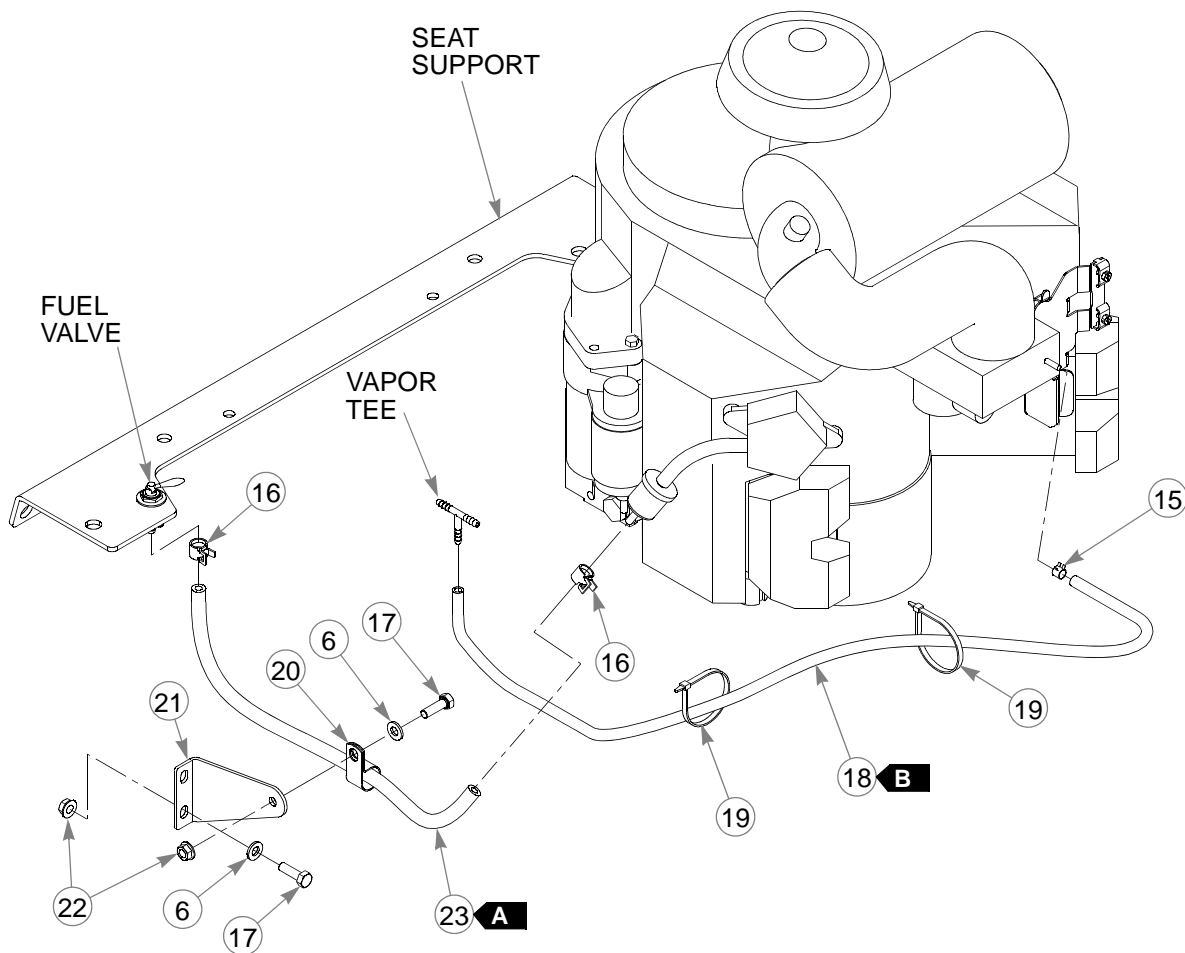

INDEX NO.	PART NO.	QTY.	DESCRIPTION
15	603112	1	CLAMP, 3/16"
16	000323	2	HOSE CLAMP
17	036236	3	CS .312-18 X 1.00 HX G5
18	603326	34"	3/16" VAPOR LINE
19	000331	4	WIRE TIE
20	043570	1	LOOP CLAMP
21	114578	1	BRACE
22	016832	3	NT .312-18 HX FLK ZNYC
23	015818	17"	1/4" FUEL LINE

NOTES:

FUEL & VAPOR LINE LENGTHS		
A	17"	VALVE TO ENGINE (FUEL)
B	34"	TEE TO ENGINE (VAPOR)

Engine Service Parts, Kawasaki FX801V, FX850V

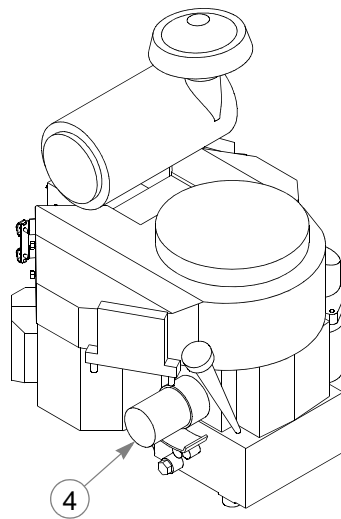
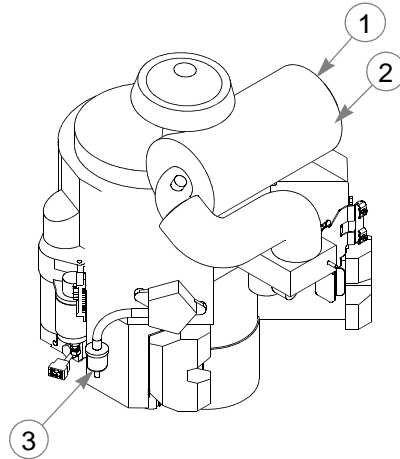

INDEX NO.	PART NO.	QTY.	DESCRIPTION
1	785261	1	MAIN AIR FILTER
2	785279	1	SAFETY AIR FILTER
3	068478	1	IN-LINE FUEL FILTER
4	603138	1	OIL FILTER

NOTES:

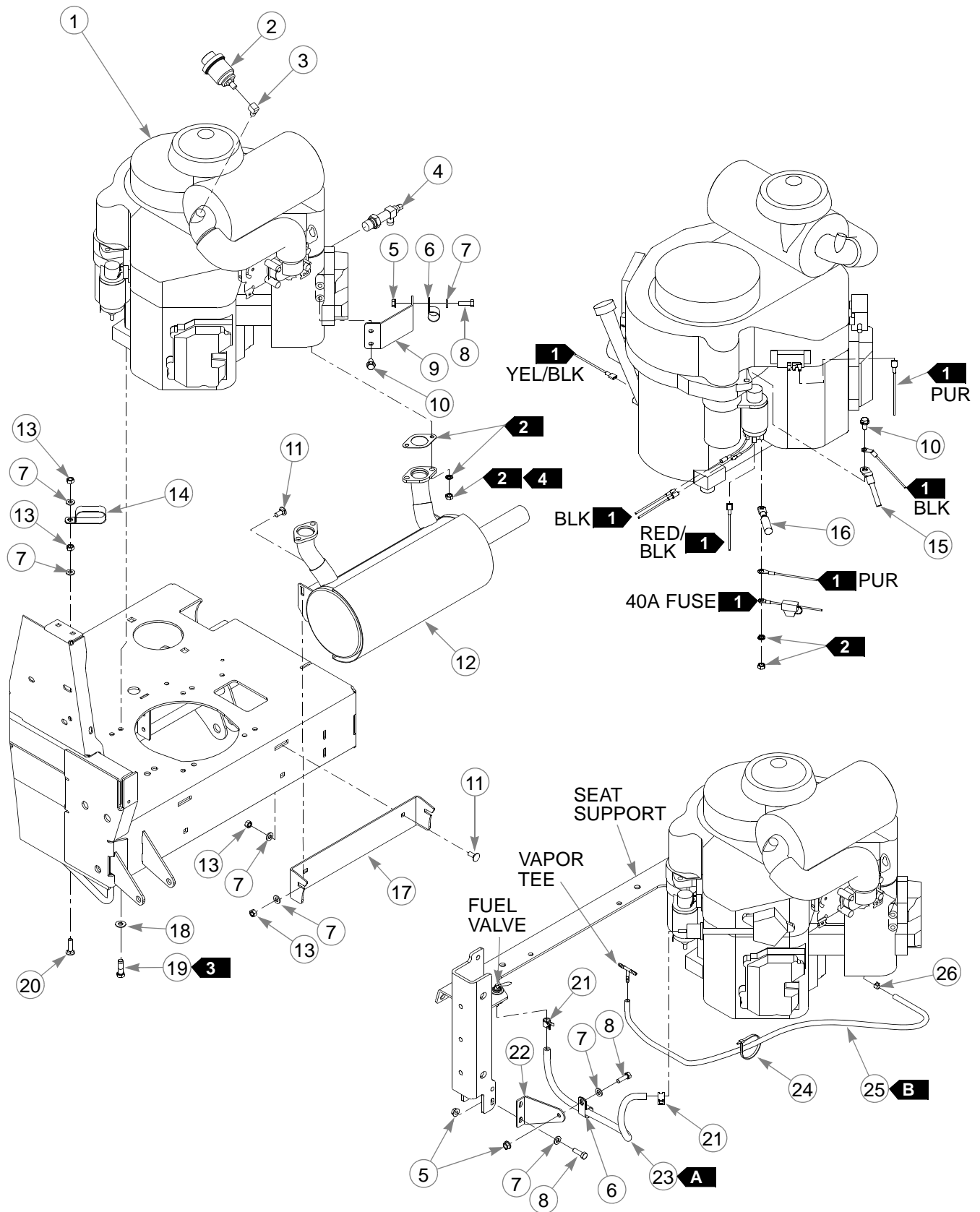

Engine, Kawasaki FX1000V



Engine, Kawasaki FX1000V

INDEX NO.	PART NO.	QTY.	DESCRIPTION
1	N/A	1	KAWASAKI FX1000V ENGINE
2	788943	1	AIR FILTER INDICATOR
3	601216	1	ELBOW STREET FITTING
4	796524	1	OIL DRAIN VALVE
5	016832	4	NT .312-18 HX FLK ZNYC
6	043570	2	LOOP CLAMP
7	768523	10	FW .343 X .687 X .051/.080H
8	036236	4	CS .312-18 X 1.00 HX G5
9	115819	1	CABLE MOUNT
10	720516	3	CS M8 X 1.25 X 16 HX FL 10.9
11	016253	4	CB .312-18 X .75 FUL ZN
12	603708	1	MUFFLER
13	034272	6	NT .312-18 HX G5
14	045088	1	HOSE CLAMP
15	605155	1	NEGATIVE BATTERY CABLE
16	604029	1	POSITIVE BATTERY CABLE
17	115889	1	MUFFLER MOUNT
18	767954	4	FW .379 X .813 X .063
19	602580	4	CS .375-16 X 1.25 HX G8 P85
20	602827	1	CB .312-18 X 1.25 ZNYC
21	000323	2	HOSE CLAMP
22	114578	1	BRACE
23	015818	14"	1/4" FUEL LINE
24	000331	5	WIRE TIE
25	603326	34"	3/16" VAPOR LINE
26	603112	1	3/16" HOSE CLAMP

NOTES:

FUEL & VAPOR LINE LENGTHS		
A 	14"	VALVE TO ENGINE (FUEL)
B 	34"	TEE TO ENGINE (VAPOR)

1. Part of the wire harness.
2. Supplied with the engine.
3. Torque to 12 ft-lbs plus 90° rotation of the cap screw head. Replace (do not reuse) the cap screw if it is removed or loosened. Use only hand tools to install this fastener.
4. Torque to 22 ft-lbs.

Engine, Kawasaki FX1000V DFI

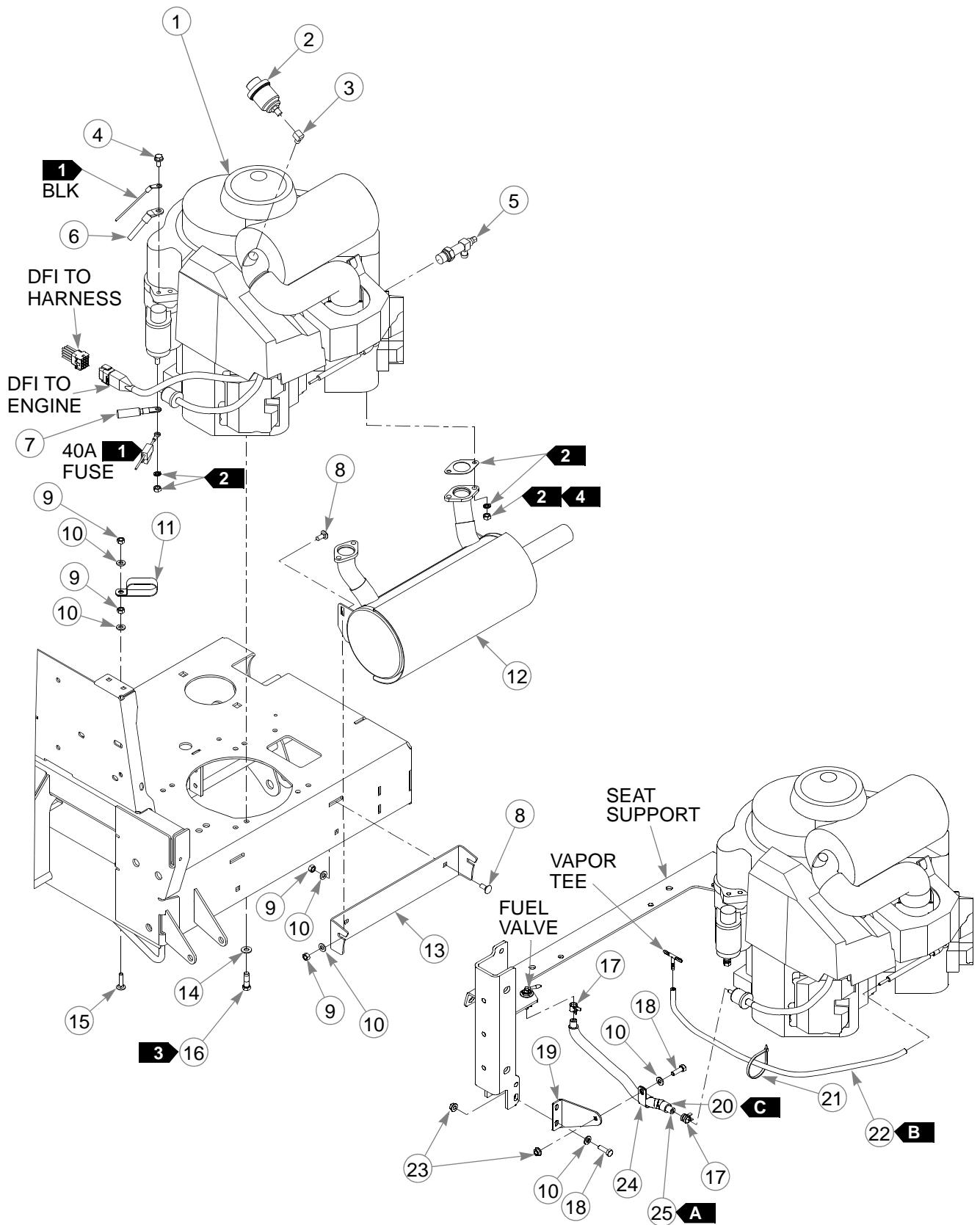

Engine, Kawasaki FX1000V DFI

INDEX NO.	PART NO.	QTY.	DESCRIPTION
1	604896	1	KAWASAKI FX1000V DFI ENGINE
2	788943	1	AIR FILTER INDICATOR
3	601216	1	ELBOW STREET FITTING
4	720516	1	CS M8 X 1.25 X 16 HX FL 10.9
5	796524	1	OIL DRAIN VALVE
6	605155	1	NEGATIVE BATTERY CABLE
7	604029	1	POSITIVE BATTERY CABLE
8	016253	4	CB .312-18 X .75 FUL ZN
9	034272	6	NT .312-18 HX G5
10	768523	9	FW .343 X .687 X .051/.080H
11	045088	1	HOSE CLAMP
12	605223	1	FX 1000V DFI MUFFLER
13	115889	1	MUFFLER MOUNT
14	767954	4	FW .379 X .813 X .063
15	602827	1	CB .312-18 X 1.25 ZNYC
16	602580	4	CS .375-16 X 1.25 HX G8 P85
17	000323	2	HOSE CLAMP
18	036236	3	CS .312-18 X 1.00 HX G5
19	114578	1	BRACE
20	605215	11"	FUEL LINE THERMAL SHIELD
21	000331	5	WIRE TIE
22	603326	23"	3/16" VAPOR LINE
23	016832	3	NT .312-18 HX FLK ZNYC
24	043570	1	LOOP CLAMP
25	015818	13"	1/4" FUEL LINE

NOTES:

FUEL & VAPOR LINE LENGTHS		
A	13"	VALVE TO ENGINE (FUEL)
B	23"	TEE TO ENGINE (VAPOR)
C	11"	VALVE TO ENGINE (FUEL LINE THERMAL SHIELD)

1. Part of the wire harness.
2. Supplied with the engine.
3. Torque to 30 ft-lbs. Replace (do not reuse) the cap screw if it is removed or loosened. Use only hand tools to install this fastener.
4. Torque to 22 ft-lbs.

Engine Service Parts, Kawasaki FX1000V

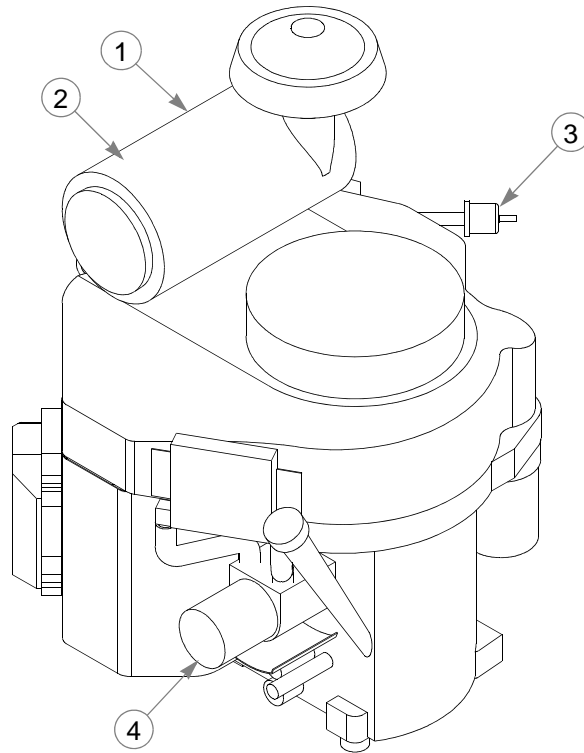

INDEX NO.	PART NO.	QTY.	DESCRIPTION
1	785261	1	MAIN AIR FILTER
2	785279	1	SAFETY AIR FILTER
3	068478	1	IN-LINE FUEL FILTER
4	603138	1	OIL FILTER

NOTES:

This page intentionally left blank.

Fuel System, Briggs & Stratton—With Carbon Canister

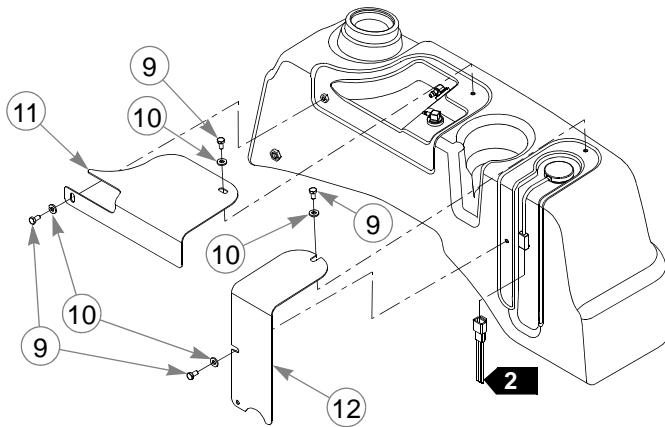
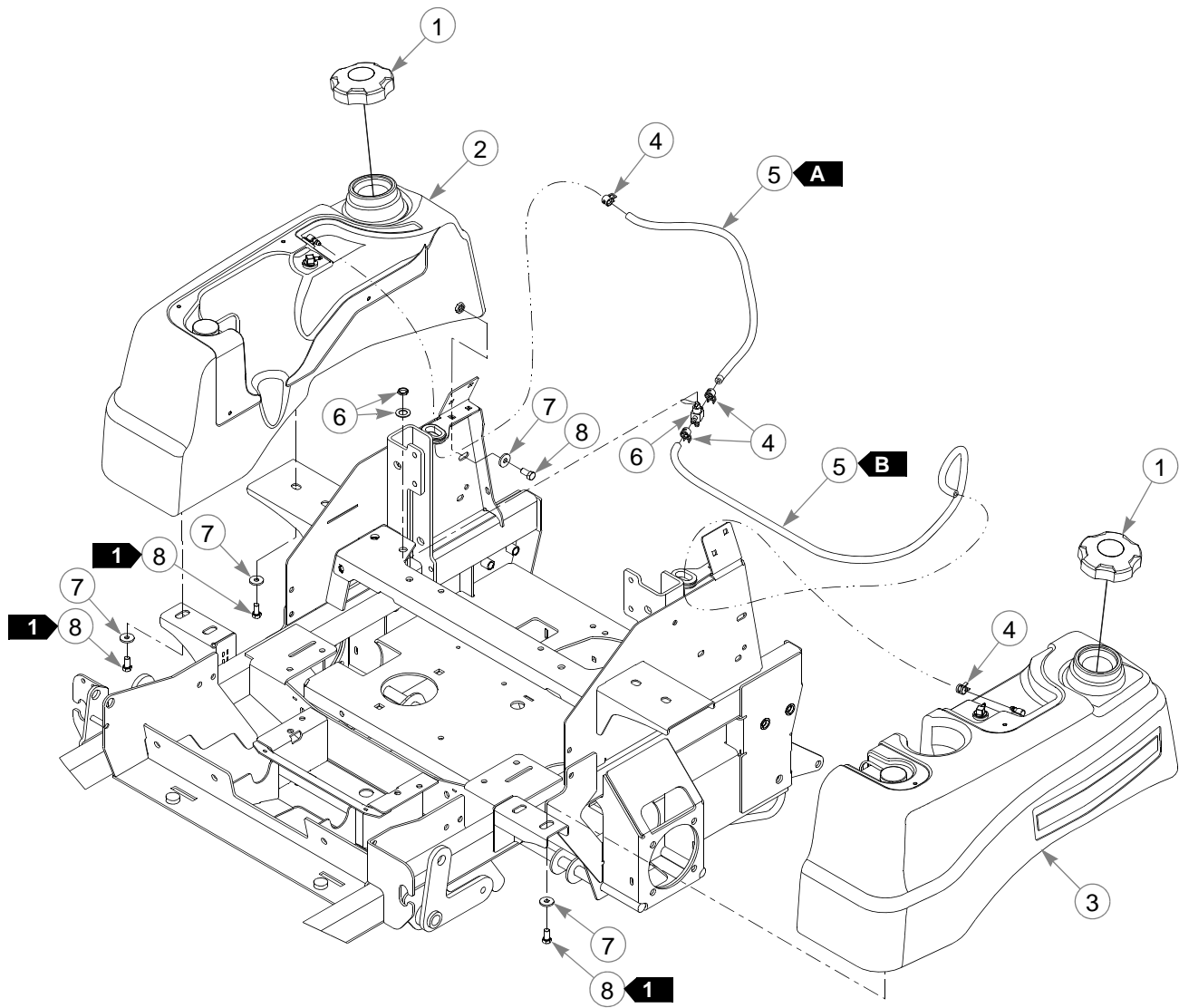

Fuel System, Briggs & Stratton—With Carbon Canister

INDEX NO.	PART NO.	QTY.	DESCRIPTION
1	603807	2	RATCHETING GAS CAP 3.5"
2	605101	1	RS FUEL TANK ASSEMBLY
3	605102	1	LS FUEL TANK ASSEMBLY
4	000323	4	HOSE CLAMP
5	015818	65"	1/4" FUEL LINE
6	745059	1	FUEL VALVE 3-WAY
7	712919	10	FW .406 X 1.00 X .12 HD
8	055822	10	CS .375-16 X .750 HX G5
9	055947	4	CS .250-20 X .50 HX G5
10	768515	4	FW .281 X .625 X .066
11	115998	1	TANK COVER
12	115999	1	TANK COVER

NOTES:

1. Torque to 20 ft-lbs.
2. Part of the wire harness.

FUEL LINE LENGTHS		
A	21"	RIGHT TANK TO VALVE (FUEL)
B	44"	LEFT TANK TO VALVE (FUEL)

Vapor System, Briggs & Stratton—With Carbon Canister

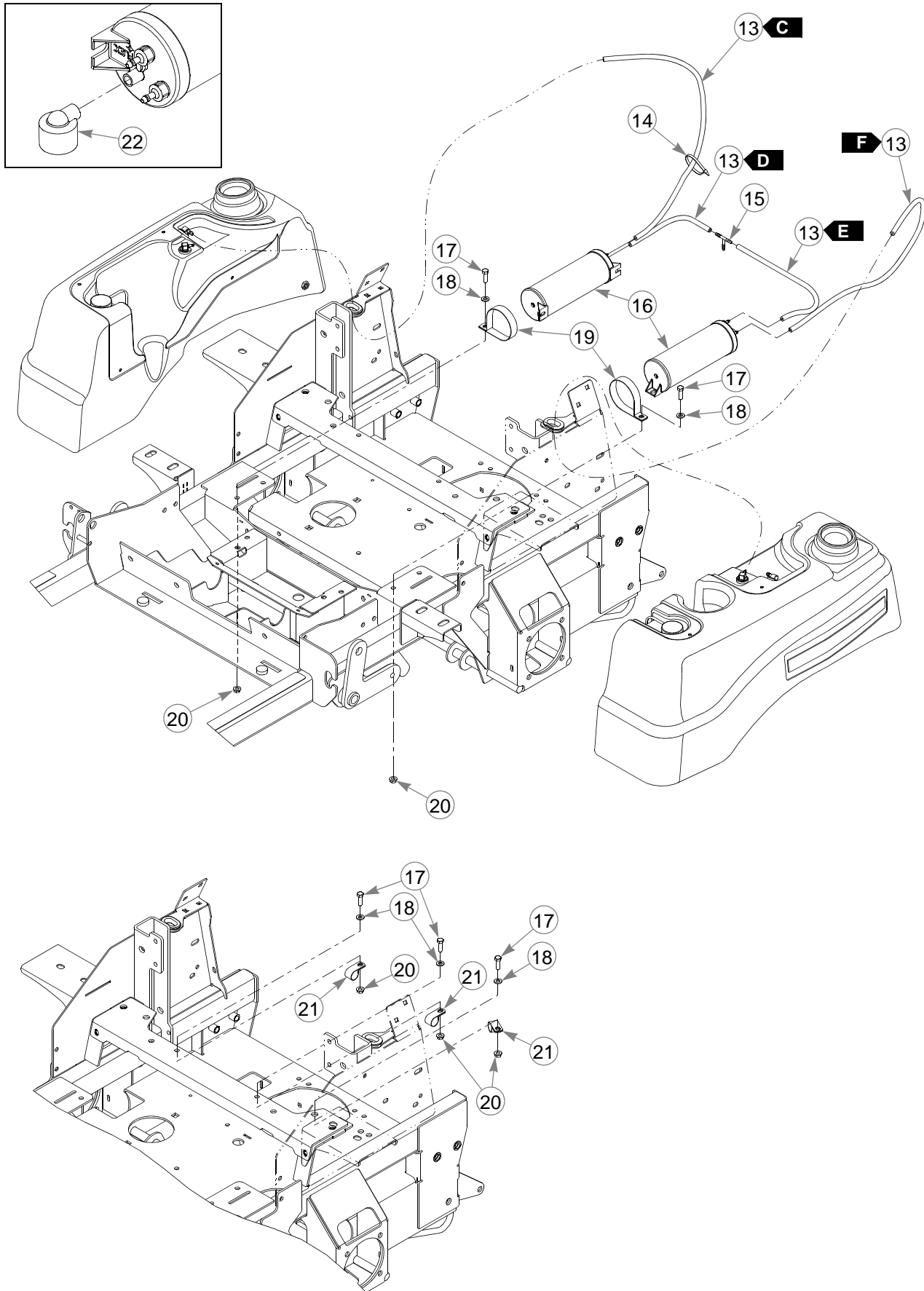

Vapor System, Briggs & Stratton—With Carbon Canister

INDEX NO.	PART NO.	QTY.	DESCRIPTION
13	603326	84"	3/16" VAPOR LINE
14	000331	1	WIRE TIE
15	604281	1	PLASTIC TEE 1/4" X 1/4" X 3/16"
16	604314	2	CARBON CANISTER
17	036236	7	CS .312-18 X 1.00 HX G5
18	768523	7	FW .343 X .687 X .051/.080H
19	602980	4	3.0" CUSHIONED CLAMP
20	016832	7	NT .312-18 HX FLK ZNYC
21	043570	3	LOOP CLAMP
22	603161	1	VACUUM BREAKER FILTER

NOTES:

VAPOR LINE LENGTHS		
C	30"	RIGHT TANK TO RIGHT CARBON CANISTER (VAPOR)
D	9"	RIGHT CARBON CANISTER TO TEE (VAPOR)
E	15"	LEFT CARBON CANISTER TO TEE (VAPOR)
F	30"	LEFT TANK TO LEFT CARBON CANISTER (VAPOR)

Fuel System, Kaw/Briggs & Stratton—W/O Carbon Canister

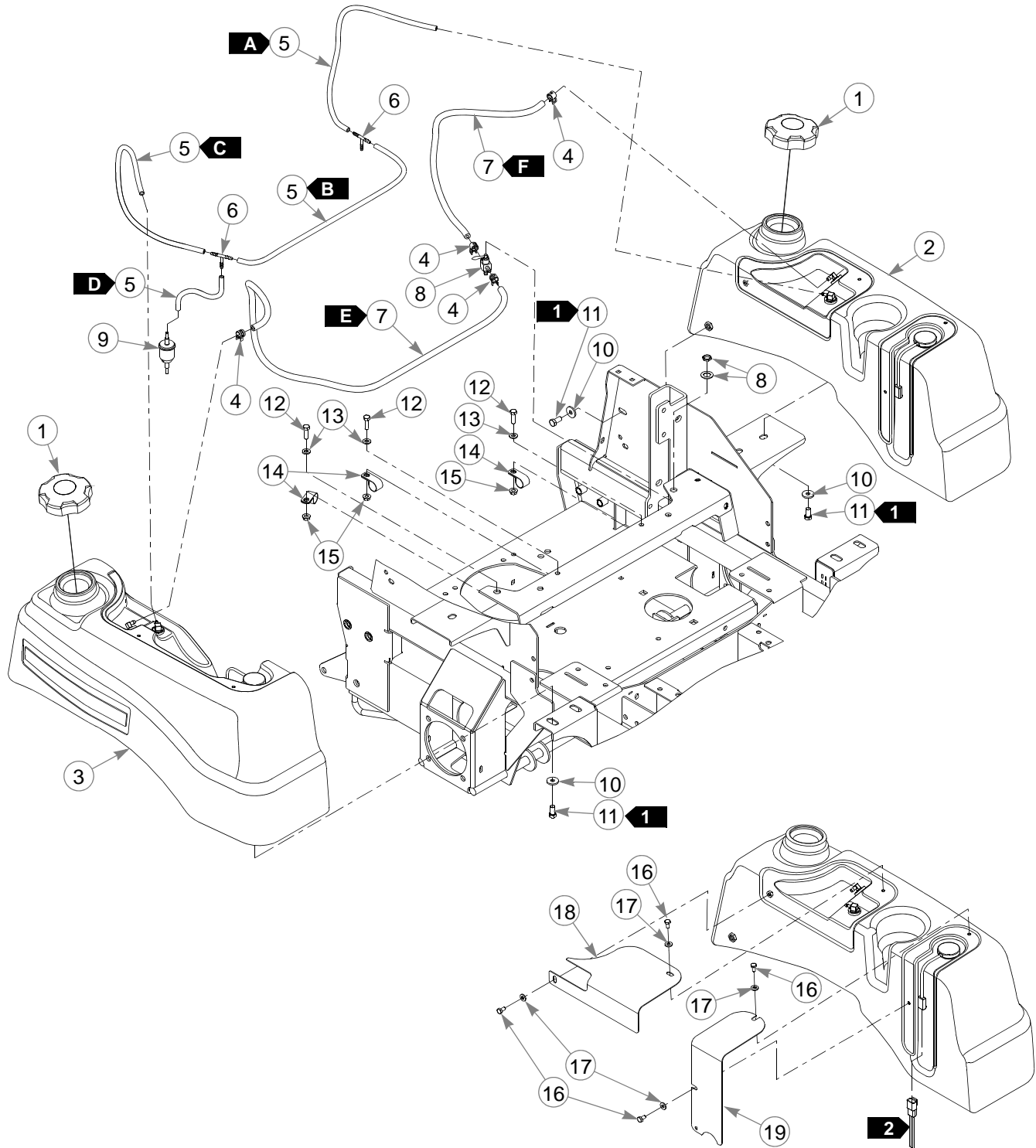

Fuel System, Kaw/Briggs & Stratton—W/O Carbon Canister

INDEX NO.	PART NO.	QTY.	DESCRIPTION
1	603807	2	RATCHETING GAS CAP 3.5"
2	605102	1	LS FUEL TANK ASSEMBLY (S/N 14044000 & HIGHER)
	604443	1	LS FUEL TANK ASSEMBLY (S/N PRIOR TO 14044000)
3	605101	1	RS FUEL TANK ASSEMBLY (S/N 14044000 & HIGHER)
	604442	1	RS FUEL TANK ASSEMBLY (S/N PRIOR TO 14044000)
4	000323	4	HOSE CLAMP
5	603326	74"	3/16" VAPOR LINE
6	604281	2	PLASTIC TEE, 3/16"
7	015818	66"	1/4" FUEL LINE
8	745059	1	FUEL VALVE 3-WAY
9	604323	1	VAPOR SYSTEM FILTER
10	712919	10	FW .406 X 1.00 X .12 HRD Z
11	055822	10	CS .375-16 X .75 HX G5
12	036236	3	CS .312-18 X 1.00 HX G5
13	768523	3	FW .343 X .687 X .051/.080H
14	043570	3	LOOP CLAMP
15	016832	3	NT .312-18 HX FLK ZNYC
16	055947	4	CS .250-20 X .500 HX G5
17	768515	4	FW .281 X .625 X .066
18	115998	1	TANK COVER
19	115999	1	TANK COVER
20	000331	1	WIRE TIE (NOT SHOWN)

NOTES:

FUEL & VAPOR LINE LENGTHS		
A	17"	LEFT TANK TO TEE (VAPOR)
B	24"	TEE TO TEE (VAPOR)
C	24"	RIGHT TANK TO TEE (VAPOR)
D	9"	TEE TO FILTER (VAPOR)
E	44"	RIGHT TANK TO VALVE (FUEL)
F	22"	LEFT TANK TO VALVE (FUEL)

1. Torque to 20 ft-lbs.
2. Part of the wire harness.

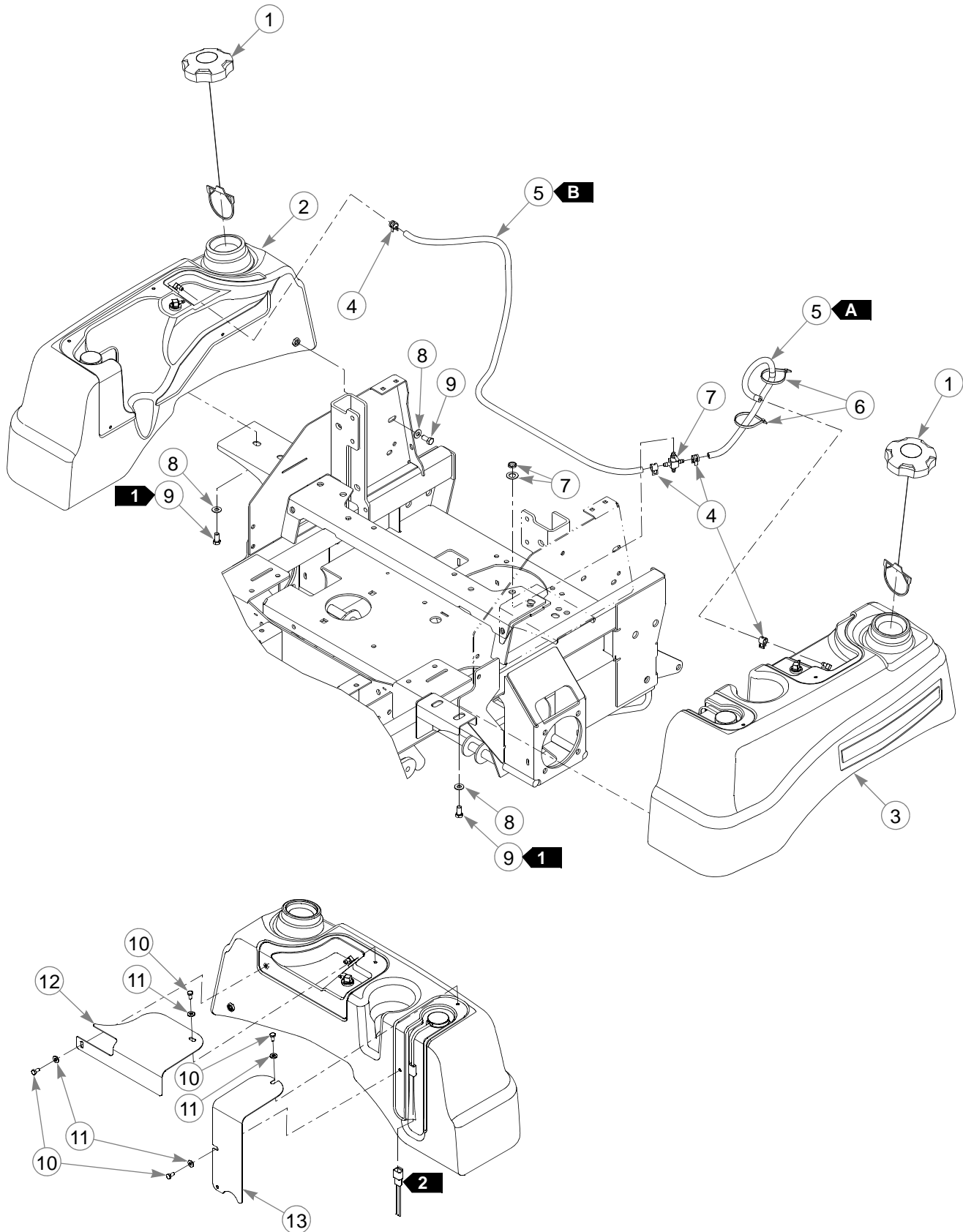

Fuel System, Kawasaki—With Carbon Canister



Fuel System, Kawasaki—With Carbon Canister

INDEX NO.	PART NO.	QTY.	DESCRIPTION
1	603807	2	RATCHETING GAS CAP, 3.5"
2	605101	1	RS FUEL TANK ASSEMBLY (S/N 14044000 & HIGHER)
	604442	1	RS FUEL TANK ASSEMBLY (PRIOR TO S/N 14044000)
3	605102	1	LS FUEL TANK ASSEMBLY (S/N 14044000 & HIGHER)
	604443	1	LS FUEL TANK ASSEMBLY (PRIOR TO S/N 14044000)
4	000323	4	HOSE CLAMP
5	015818	65"	1/4" FUEL LINE
6	000331	3	WIRE TIE
7	745059	1	FUEL VALVE 3-WAY
8	767954	10	FW .379 X .813 X .063
9	055822	10	CS .375-16 X .75 HX G5
10	055947	4	CS .250-20 X .50 HX G5
11	768515	4	FW .281 X .625 X .066
12	115998	1	TANK COVER
13	115999	1	TANK COVER

NOTES:

FUEL LINE LENGTHS		
	21"	LEFT TANK TO VALVE (FUEL)
	44"	RIGHT TANK TO VALVE (FUEL)

1. Torque to 20 ft-lbs.
2. Part of the wire harness.



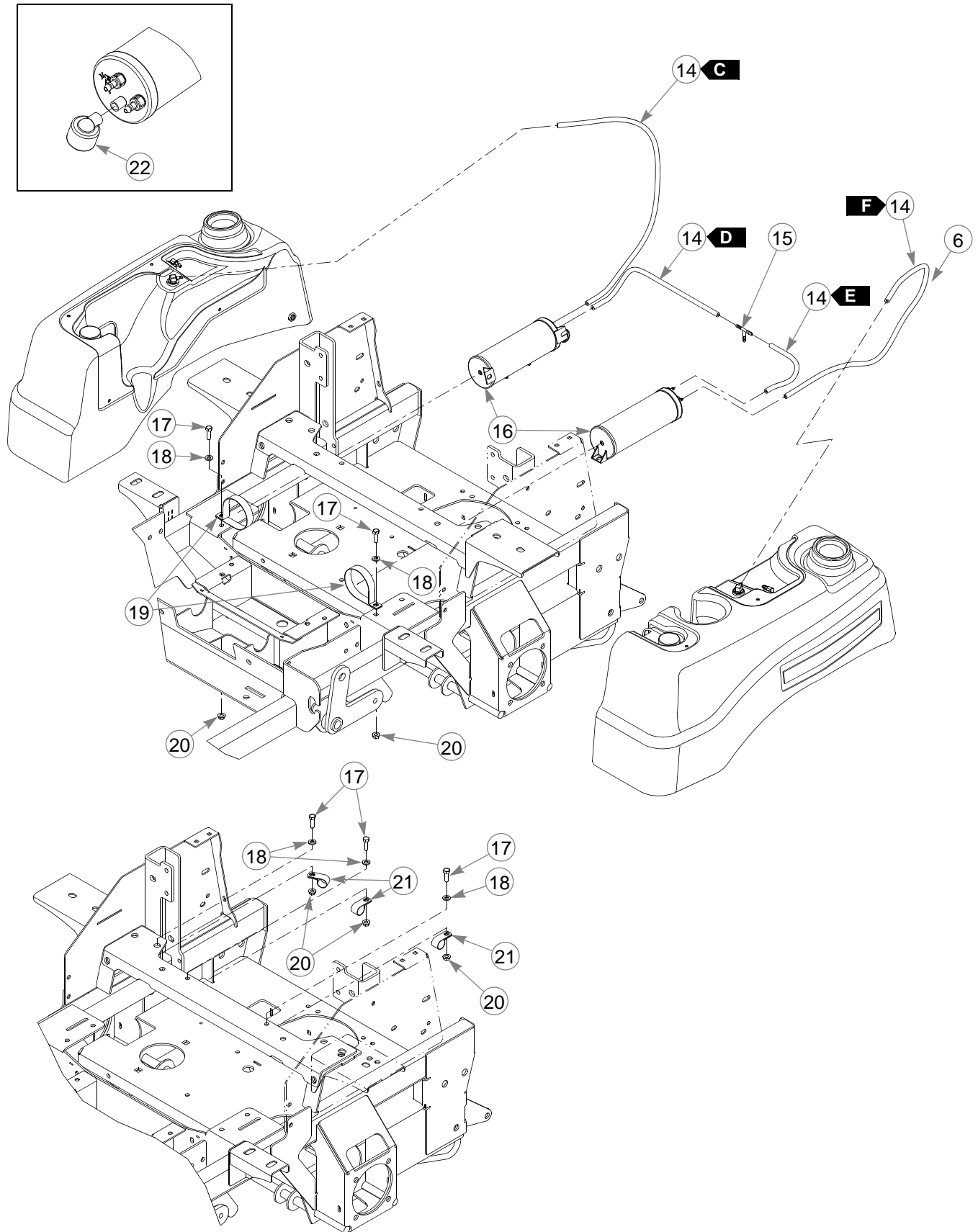

Vapor System, Kawasaki—With Carbon Canister



Vapor System, Kawasaki—With Carbon Canister

INDEX NO.	PART NO.	QTY.	DESCRIPTION
14	603326	84"	3/16" VAPOR LINE
15	604281	1	PLASTIC TEE 1/4" X 1/4" X 3/16"
16	604314	2	CARBON CANISTER
17	036236	7	CS .312-18 X 1.00 HX G5
18	768523	7	FW .343 X .687 X .051/.080H
19	602980	4	3.0" CUSHIONED CLAMP
20	016832	7	NT .312-18 HX FLK ZNYC
21	043570	3	LOOP CLAMP
22	603161	1	VACUUM BREAKER FILTER

NOTES:

VAPOR LINE LENGTHS		
	30"	RIGHT TANK TO RIGHT CARBON CANISTER (VAPOR)
	15"	RIGHT CARBON CANISTER TO TEE (VAPOR)
	9"	LEFT CARBON CANISTER TO TEE (VAPOR)
	30"	LEFT TANK TO LEFT CARBON CANISTER (VAPOR)

Fuel System, Kawasaki—DFI

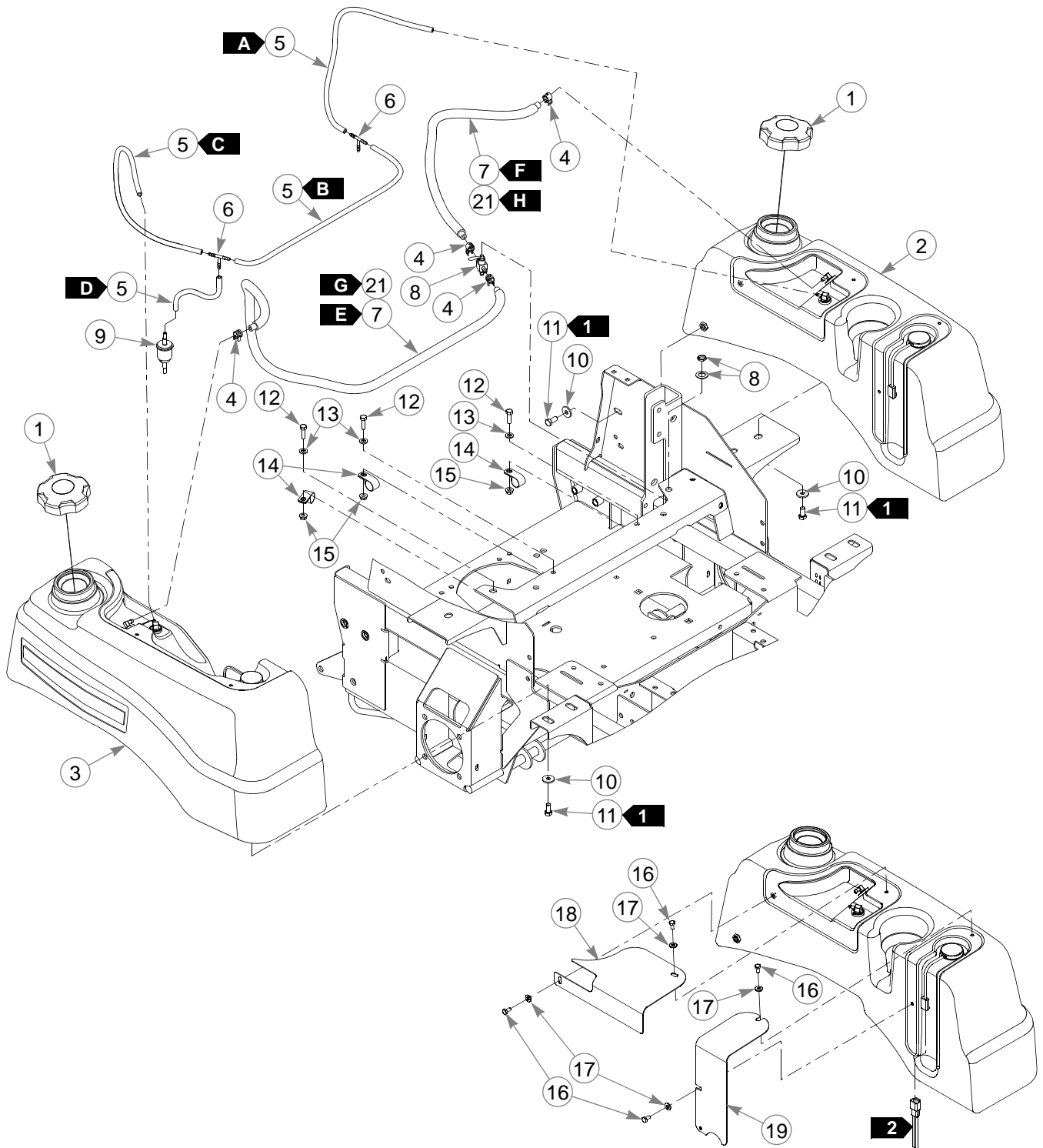

Fuel System, Kawasaki—DFI

INDEX NO.	PART NO.	QTY.	DESCRIPTION
1	603807	2	RATCHETING GAS CAP, 3.5"
2	605102	1	LS FUEL TANK (S/N 14061079 & HIGHER)
	604443	1	LS FUEL TANK (S/N PRIOR TO 14061079)
3	605101	1	RS FUEL TANK (S/N 14061079& HIGHER)
	604442	1	RS FUEL TANK (S/N PRIOR TO 14061079)
4	000323	4	HOSE CLAMP
5	603326	74"	3/16" VAPOR LINE
6	604281	2	PLASTIC TEE, 3/16"
7	015818	66"	1/4" FUEL LINE
8	745059	1	FUEL VALVE 3-WAY
9	604323	1	VAPOR SYSTEM FILTER
10	712927	10	FW .344 X 1.00 X .12 HRD Z
11	055822	10	CS .375-16 X .75 HX G5
12	036236	3	CS .312-18 X 1.00 HX G5
13	768523	3	FW .343 X .687 X .051/.080H
14	043570	3	LOOP CLAMP
15	016832	3	NT .312-18 HX FLK ZNYC
16	055947	4	CS .250-20 X .50 HX G5
17	768515	4	FW .281 X .625 X .066
18	115998	1	TANK COVER
19	115999	1	TANK COVER
20	000331	1	WIRE TIE (NOT SHOWN)
21	605215	62"	FUEL LINE THERMAL SHIELD

NOTES:

FUEL LINE LENGTHS		
A	17"	LEFT TANK TO TEE (VAPOR)
B	24"	TEE TO TEE (VAPOR)
C	24"	RIGHT TANK TO TEE (VAPOR)
D	9"	TEE TO FILTER (VAPOR)
E	44"	RIGHT TANK TO VALVE (FUEL)
F	22"	LEFT TANK TO VALVE (FUEL)
G	42"	RIGHT TANK TO VALVE (THERMAL SHIELD)
H	20"	LEFT TANK TO VALVE (THERMAL SHIELD)

1. Torque to 20 ft-lbs.
2. Part of the wire harness.

Fuel Tank Service Parts—S/N 14044000 & Higher

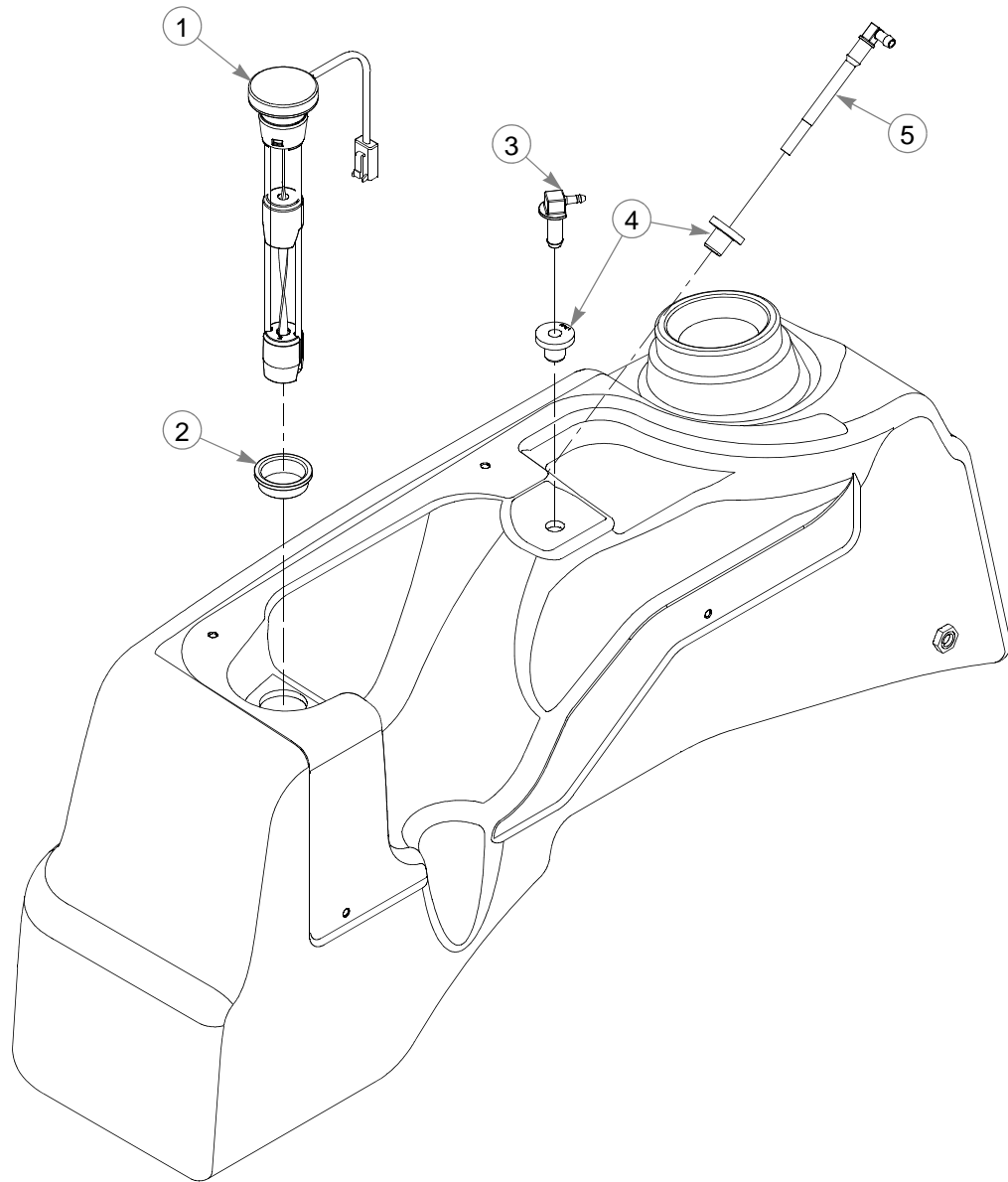

INDEX NO.	PART NO.	QTY.	DESCRIPTION
1	603888	1	FUEL SENDER
2	605648	1	GROMMET
3	604287	1	VENT FITTING
4	604200	2	GROMMET
5	605156	1	SUCTION HOSE ASSEMBLY

Fuel Tank Service Parts—S/N Prior to 14044000

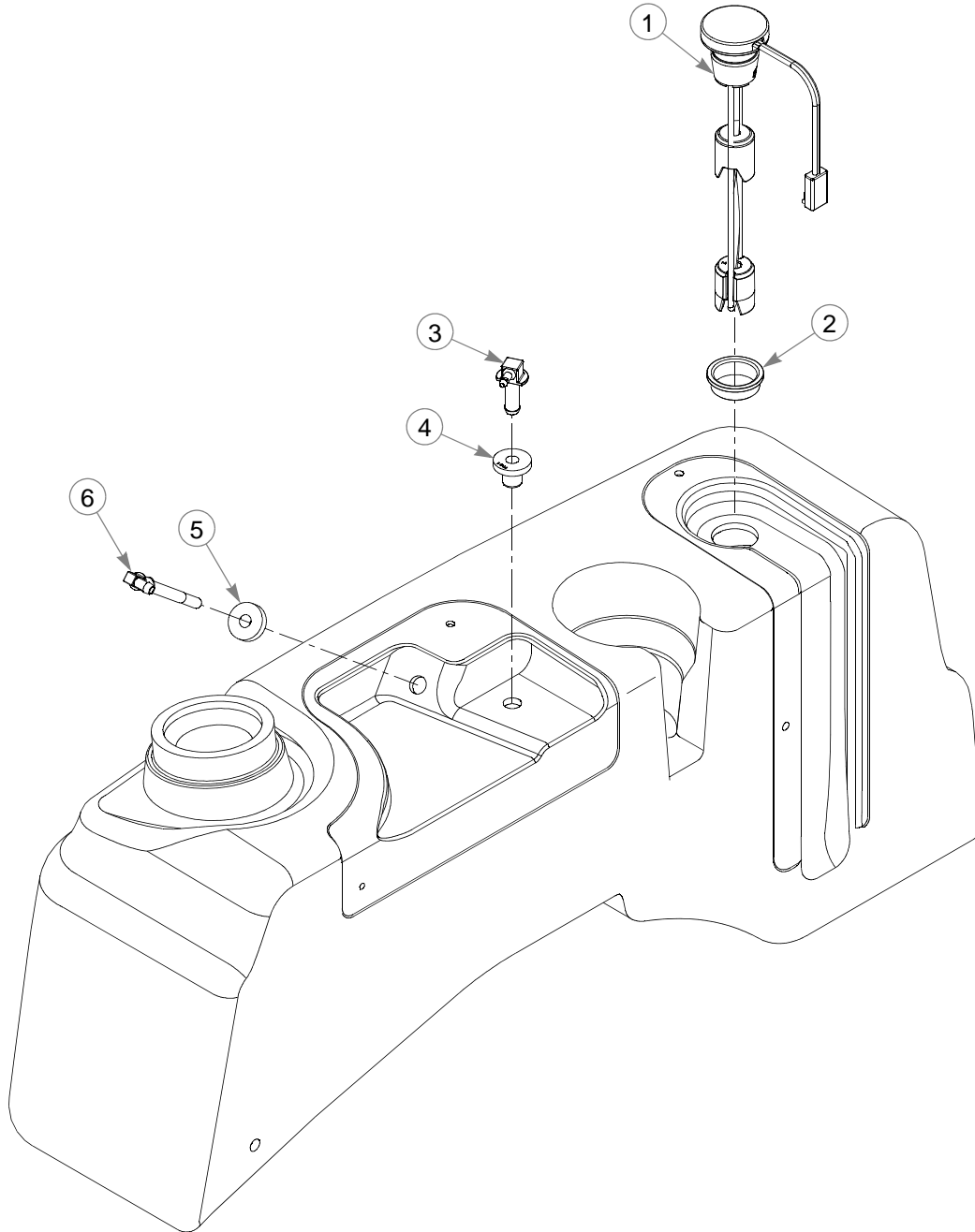

INDEX NO.	PART NO.	QTY.	DESCRIPTION
1	603888	1	FUEL SENDER
2	605648	1	GROMMET
3	604287	1	VENT FITTING
4	604200	1	GROMMET
5	785295	1	GROMMET
6	601805	1	SUCTION HOSE ASSEMBLY 22.0"

Section 6

Battery	6-2
Instrument Panel—Briggs & Stratton Engines.	6-4
Instrument Panel—Kawasaki Engines.	6-6
Instrument Panel—Kawasaki DFI Engines	6-8

Battery

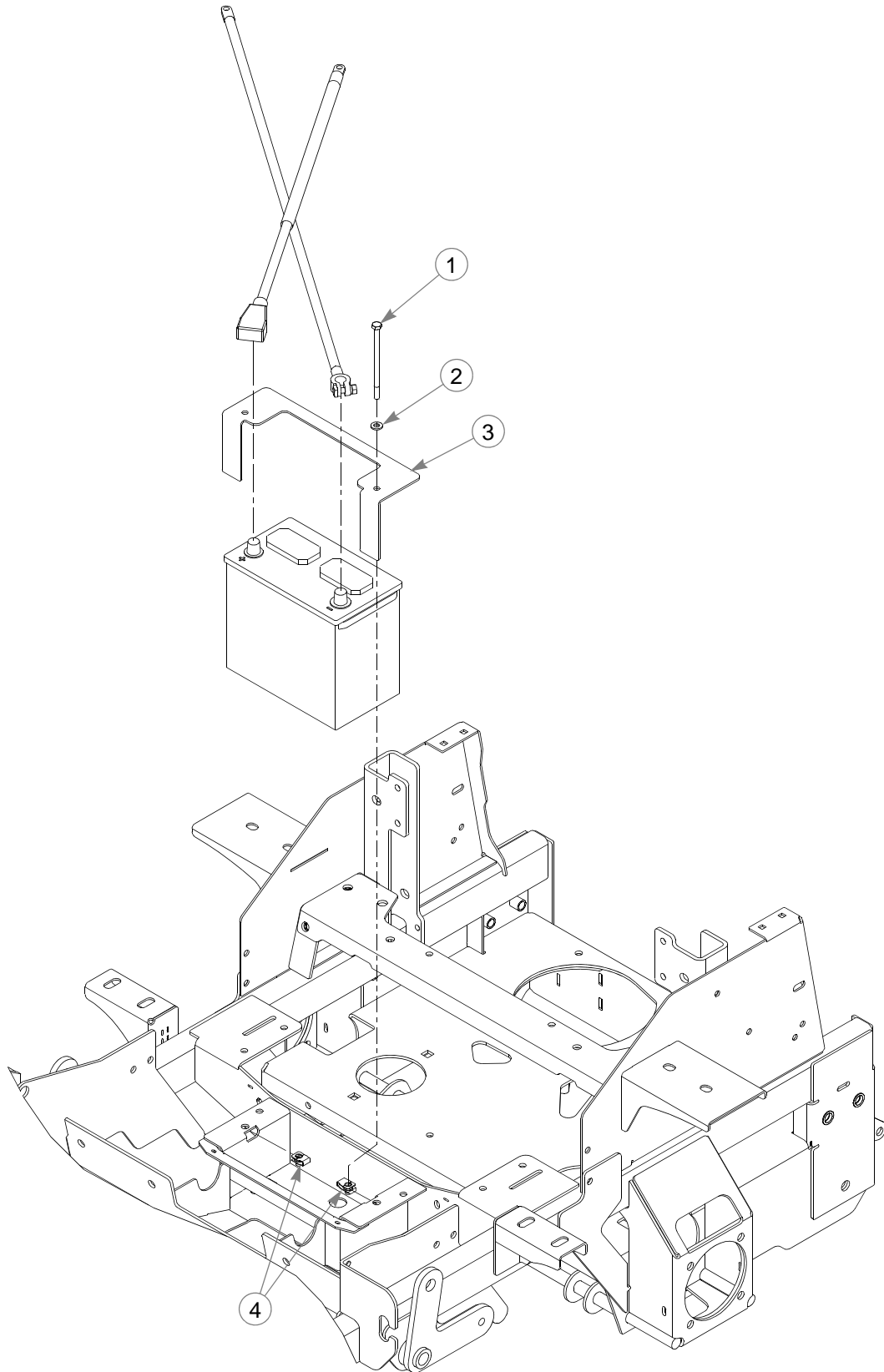

Battery

INDEX NO.	PART NO.	QTY.	DESCRIPTION
1	050823	2	CS .312-18 X 5.00 HX G5
2	768523	2	FW .343 X .687 X .051/.080H
3	113676	1	BATTERY STRAP
4	601069	2	CN .312-18 X .20 MAX THK

NOTES:

Instrument Panel—Briggs & Stratton Engines

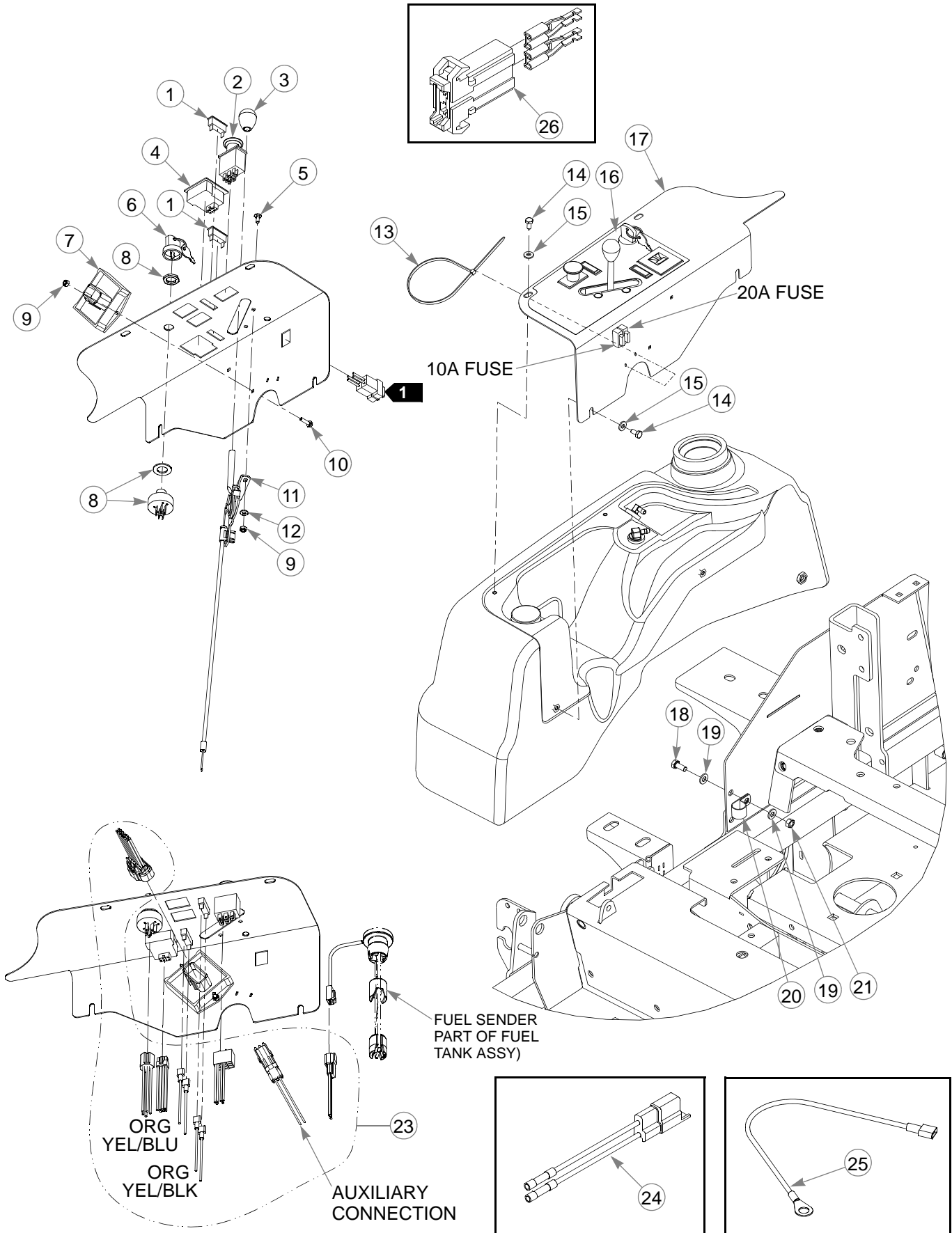

Instrument Panel—Briggs & Stratton Engines

INDEX NO.	PART NO.	QTY.	DESCRIPTION
1	712257	2	RED INDICATOR LIGHT
2	776476	1	PTO SWITCH
3	603523	1	KNOB
4	603748	1	FUEL DISPLAY/HOUR METER
5	601098	2	CB 10-24 X .500 ZYNC
6	785808	1	KEY ASSEMBLY
7	604373	1	RELAY CONTROL MODULE
8	045898	1	IGNITION SWITCH
9	059832	4	NT #10-24 HX NL ZN
10	063198	2	CS 10-24 X .75 HX FLK ZN
11	605836	1	THROTTLE CABLE 50"
12	704932	2	FW .219 X .500 X .048 ZNYC
13	000430	1	WIRE TIE
14	055947	4	CS .250-20 X .50 HX G5
15	768515	4	FW .281 X .625 X .066
16	605767	1	INSTRUMENT PANEL DECAL
17	551451	1	INSTRUMENT PANEL (WITH DECAL)
18	034280	1	CS .312-18 X .75 HX G5
19	768523	2	FW .343 X .687 X .051/.080H
20	043570	1	LOOP CLAMP
21	034272	1	NT .312-18 HX G5
22	000331	8	WIRE TIE (NOT SHOWN)
23	605456	1	WIRE HARNESS
24	114052	1	CLUTCH CONNECTOR REPAIR KIT
25	604430	1	WIRE HARNESS
26	601047	1	FUSE HOLDER

NOTES:

1. Part of the wire harness.

Instrument Panel—Kawasaki Engines

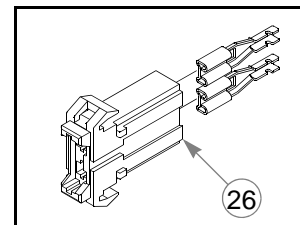
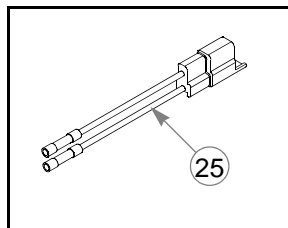
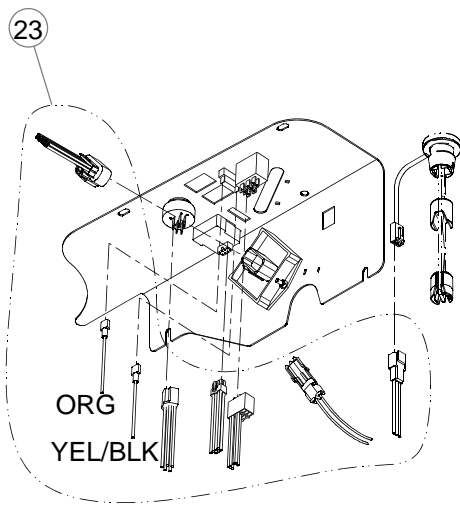
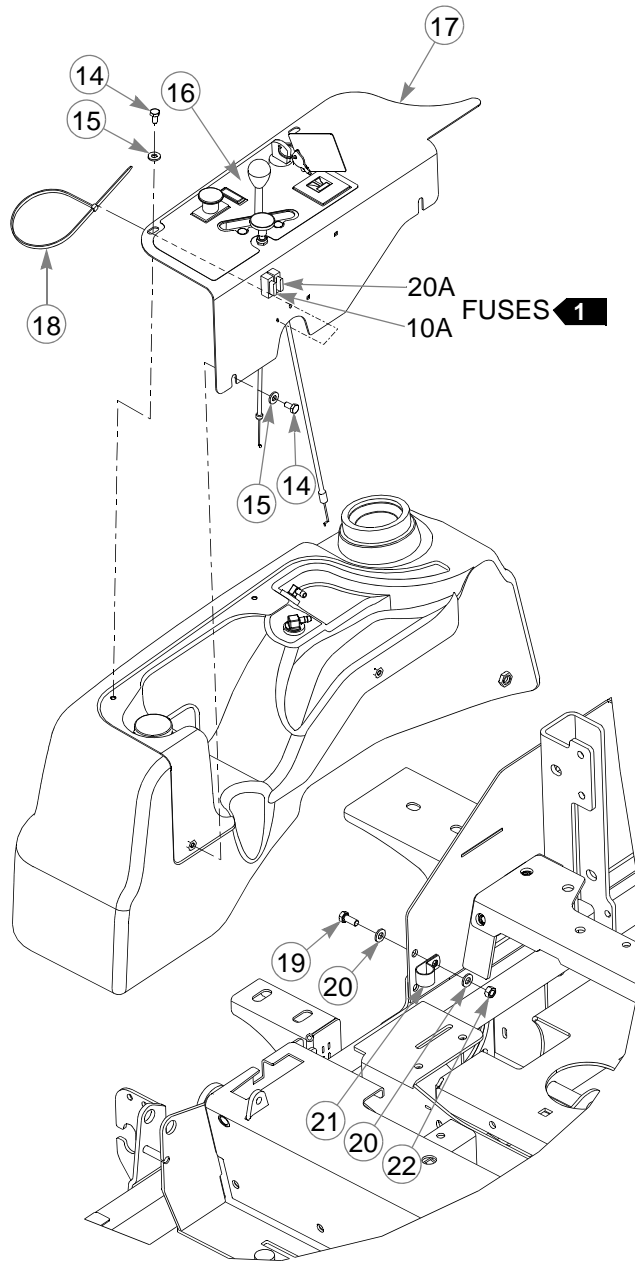
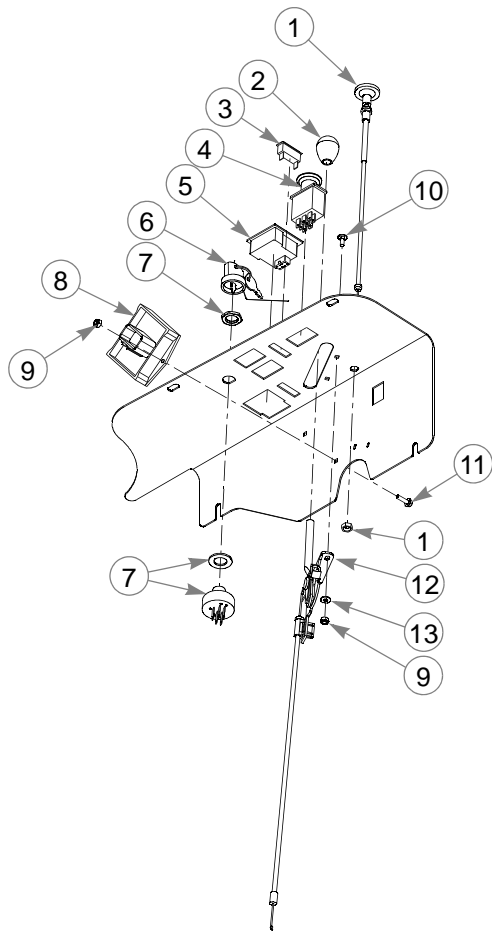

Instrument Panel—Kawasaki Engines

INDEX NO.	PART NO.	QTY.	DESCRIPTION
1	601095	1	CHOKE CABLE
2	603523	1	KNOB
3	712257	1	RED INDICATOR LIGHT
4	776476	1	PTO SWITCH
5	603748	1	FUEL DISPLAY/HOUR METER
6	785808	1	KEY ASSEMBLY
7	045898	1	IGNITION SWITCH
8	604373	1	RELAY CONTROL MODULE
9	059832	4	NT #10-24 HX NL ZN
10	601098	2	CB 10-24 X .500 ZYNC
11	063198	2	CS 10-24 X .75 HX FLK ZN
12	603847	1	THROTTLE CABLE 50"
13	704932	2	FW .219 X .500 X .048 ZNYC
14	055947	4	CS .250-20 X .50 HX G5
15	768515	4	FW .281 X .625 X .066
16	603916	1	INSTRUMENT PANEL DECAL
17	551451	1	INSTRUMENT PANEL (WITH DECAL)
18	000430	1	WIRE TIE
19	034280	1	CS .312-18 X .75 HX G5
20	768523	2	FW .343 X .687 X .051/.080H
21	043570	1	LOOP CLAMP
22	034272	1	NT .312-18 HX G5
23	604241	1	WIRE HARNESS
24	000331	6	WIRE TIE (NOT SHOWN)
25	114052	1	CLUTCH CONNECTOR REPAIR KIT
26	601047	1	FUSE HOLDER

NOTES:

1. Part of the wire harness.

Instrument Panel—Kawasaki DFI Engines

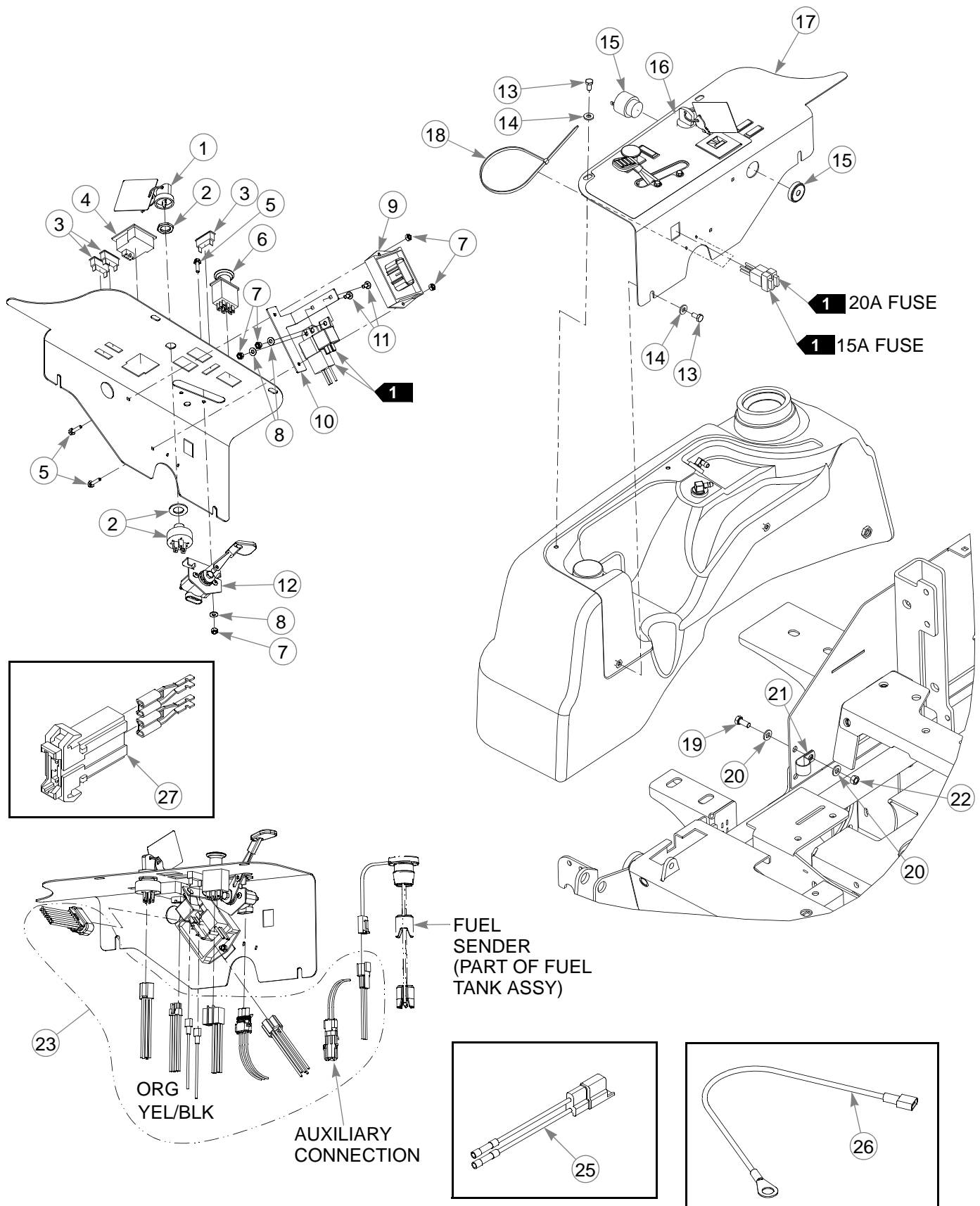

Instrument Panel—Kawasaki DFI Engines

INDEX NO.	PART NO.	QTY.	DESCRIPTION
1	785808	1	KEY ASSEMBLY
2	045898	1	IGNITION SWITCH
3	712257	3	RED INDICATOR LIGHT
4	603748	1	FUEL DISPLAY/HOUR METER
5	063198	4	CS 10-24 X .75 HX FLK ZN
6	776476	1	PTO SWITCH
7	059832	6	NT #10-24 HX NL ZN
8	704932	4	FW .219 X .500 X .048 ZNYC
9	604373	1	RELAY CONTROL MODULE
10	120808	1	RELAY BRACKET
11	601098	2	CB 10-24 X .500 ZYNC
12	604986	1	THROTTLE ASSEMBLY
13	055947	4	CS .250-20 X .50 HX G5
14	768515	4	FW .281 X .625 X .066
15	794347	1	ALARM
16	604985	1	INSTRUMENT PANEL DECAL
17	552729	1	INSTRUMENT PANEL (WITH DECAL)
18	000430	1	WIRE TIE
19	034280	1	CS .312-18 X .75 HX G5
20	768523	2	FW .343 X .687 X .051/.080H
21	043570	1	LOOP CLAMP
22	034272	1	NT .312-18 HX G5
23	604828	1	WIRE HARNESS
24	000331	8	WIRE TIE (NOT SHOWN)
25	114052	1	CLUTCH CONNECTOR REPAIR KIT
26	604430	1	SOLENOID JUMPER
27	601047	1	FUSE HOLDER

NOTES:

1. Part of the wire harness.

Section 7

54" Side Discharge Service Deck	7-2
54" Side Discharge Deck Pulleys & Spindles	7-4
54" Side Discharge Deck	7-6
60" Side Discharge Service Deck	7-8
60" Side Discharge Deck Pulleys & Spindles	7-10
60" Side Discharge Deck	7-12
66" Side Discharge Service Deck	7-14
66" Side Discharge Deck Pulleys & Spindles	7-16
66" Side Discharge Deck	7-18
72" Side Discharge Service Deck	7-20
72" Side Discharge Deck Pulleys & Spindles	7-22
72" Side Discharge Deck	7-24
60" Rear Discharge Service Deck	7-26
60" Rear Discharge Deck Pulleys & Spindles	7-28
60" Rear Discharge Dust Shield	7-32
60" Rear Discharge Deck	7-34
72" Rear Discharge Service Deck	7-38
72" Rear Discharge Deck Pulleys & Spindles	7-40
72" Rear Discharge Dust Shield	7-44
72" Rear Discharge Deck	7-46
Deck Lift	7-50
Deck Mounting Hardware	7-52

54" Side Discharge Service Deck

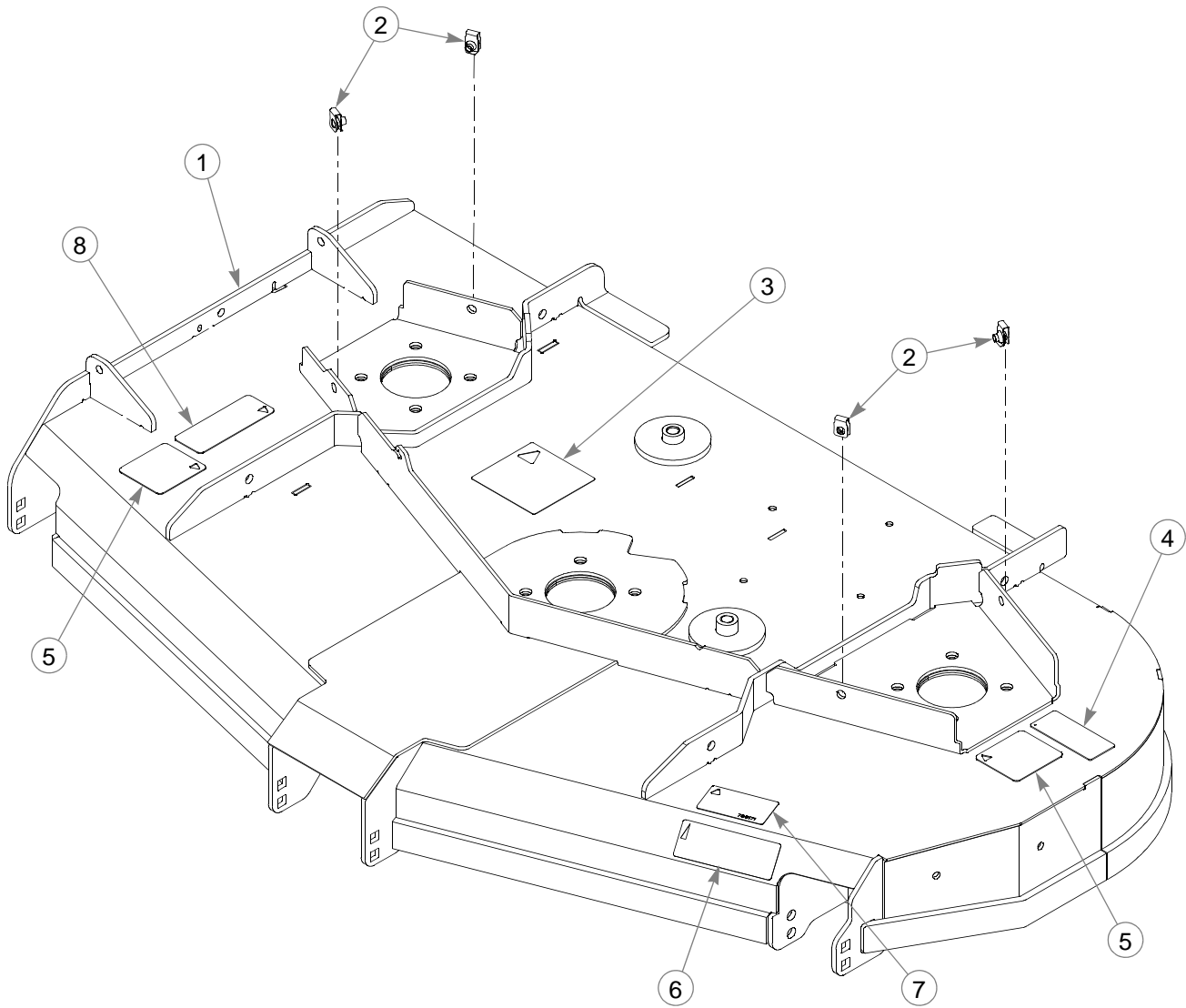

54" Side Discharge Service Deck

INDEX NO.	PART NO.	QTY.	DESCRIPTION
1	553085	1	54" DECK (WITH DECALS)
2	601069	4	CN .312-18 X .20 MAX THK
3	781419	1	BELT ROUTING DECAL
4	601892	1	THROWN OBJECTS DECAL
5	601837	2	DECK DANGERS DECAL
6	603092	1	VX4 TECHNOLOGY DECAL
7	799171	1	54" DECK ID DECAL
8	601624	1	DISCHARGE CHUTE DECAL

NOTES:

54" Side Discharge Deck Pulleys & Spindles

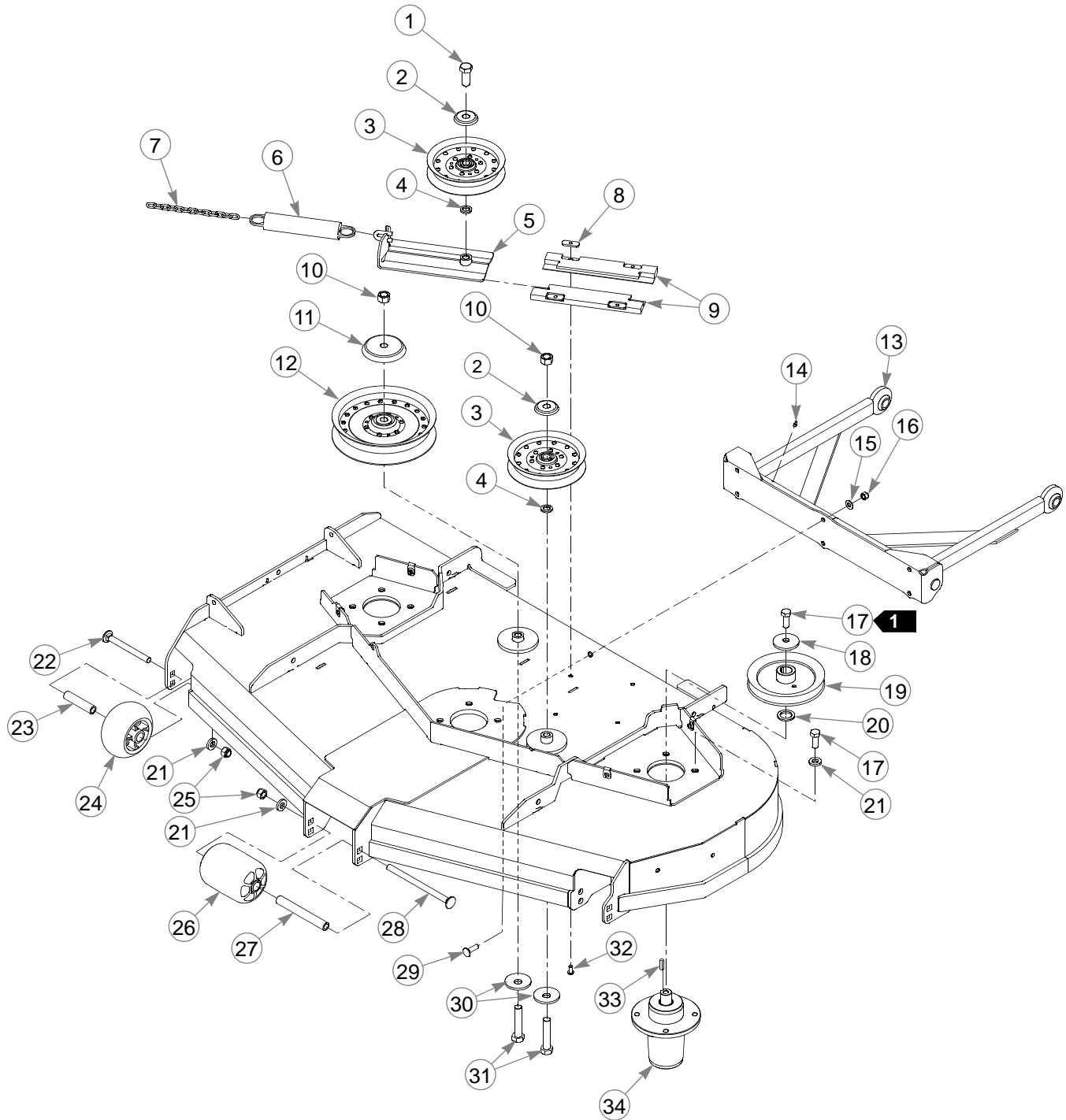

54" Side Discharge Deck Pulleys & Spindles

INDEX NO.	PART NO.	QTY.	DESCRIPTION
1	794446	1	CS .625-11 X 1.50 HX G5
2	602935	2	IDLER DUST SHIELD SM
3	602821	2	IDLER 6.0" RIVETED
4	028118	2	FW .625 X 1.00 X .134
5	350884	1	DECK IDLER SLIDE
6	781302	1	TENSION SPRING
7	259812	1	CHAIN, 13 LINK
8	603023	4	WN .312-18 ZN
9	602936	2	UHMW IDLER SLIDE
10	016972	2	NT .625-11 HX G5 ZNYC
11	602963	1	IDLER DUST SHIELD LG
12	602838	1	IDLER 8.0" RIVETED
13	113340	1	PUSHER
14	015495	2	GREASE FITTING STRAIGHT
15	767954	6	FW .379 X .813 X .063
16	086660	6	NT .375-16 HX G5 NL
17	705954	15	CS .500-13 X 1.25 HX G5
18	752386	3	CW .515 X 2.25 X .204 BLK
19	798975	3	PULLEY
20	045765	3	FW 1.030 X 1.50 X .134
21	767962	15	FW .531 X 1.063 X .175
22	603049	2	CB .500-13 X 5.00 ZNYC
23	602345	2	SPACER 3.22
24	602263	2	PLASTIC WHEEL
25	781567	3	NT .500-13 HX G8 ZY NL
26	602341	1	PLASTIC WHEEL
27	602344	1	SPACER 5.73
28	602338	1	CB .500-13 X 7.50 STD ZN
29	603113	6	CB .375-16 X 1.25 G5 ZN
30	782474	2	CW .631 X 2.25 X .187 PNT
31	783738	2	CS .625-11 X 3.00 FULL HX G5
32	603022	4	CS .312-18 X .625 BH ZN
33	212472	3	KEY 1/4 SQ X 1.00
34	604255	3	BLADE SPINDLE CW

NOTES:

1. Torque to 67–75 ft-lbs.

54" Side Discharge Deck

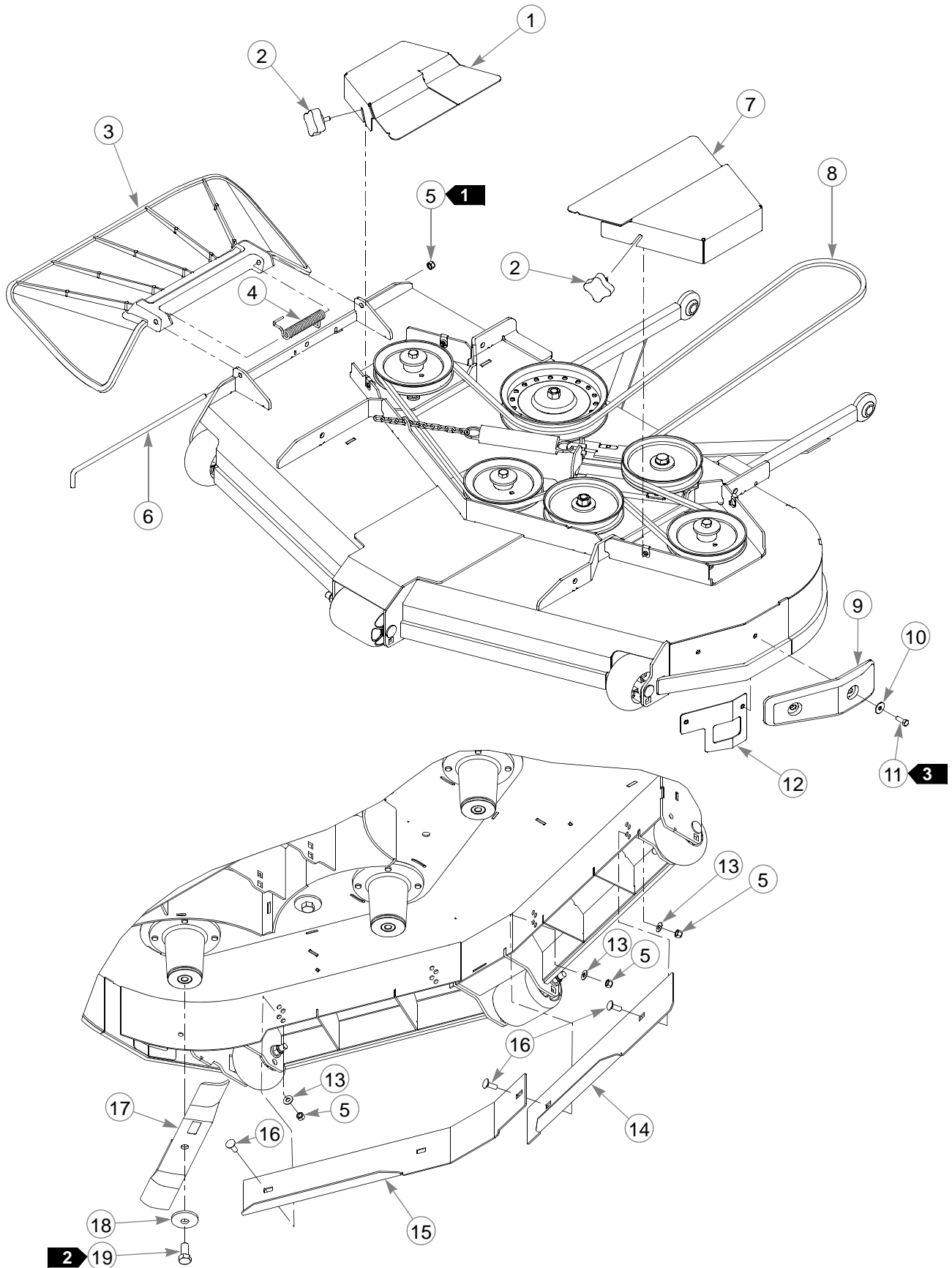

54" Side Discharge Deck

INDEX NO.	PART NO.	QTY.	DESCRIPTION
1	121895	1	PULLEY COVER RS
2	792002	4	KNOB 5/16-18 X 3/4"
3	602429	1	DISCHARGE CHUTE
4	602435	1	TORSION SPRING
5	086660	5	NT .375-16 HX G5 ZY NL
6	602432	1	CHUTE PIN
7	121894	1	PULLEY COVER LS
8	601715	1	BELT, B 162.0" EL
9	602817	1	RUBBER BUMPER
10	079210	2	FW .344 X 1.00 X .06 ZNYC
11	064014	2	CS .312-18 X .875 HX G5
12	113563	1	BACKING PLATE
13	767954	4	FW .379 X .813 X .063
14	113211	1	RS ADJ INNER WALL
15	113210	1	LS ADJ INNER WALL
16	025395	4	CB .375-16 X 1.00 G5 ZNY
17	797696	3	BLADE, F18.50"-H-F-CW
	601014	3	BLADE, F16.50"-L-F-CW
	601123	3	BLADE, 16.50"-L-F-CW
	796623	3	BLADE, 16.50"-MUL-F-CW
	796631	3	BLADE, 16.50"-GAT-F-CW
18	782474	3	CW .631 X 2.25 X .187 PNT
19	781872	3	CS .625-11 X 1.25 HX G5 Z

NOTES:

1. Do not torque; the discharge chute must pivot freely.
2. Torque to 118 ft-lbs.
3. Torque to 10 ft-lbs.

60" Side Discharge Service Deck

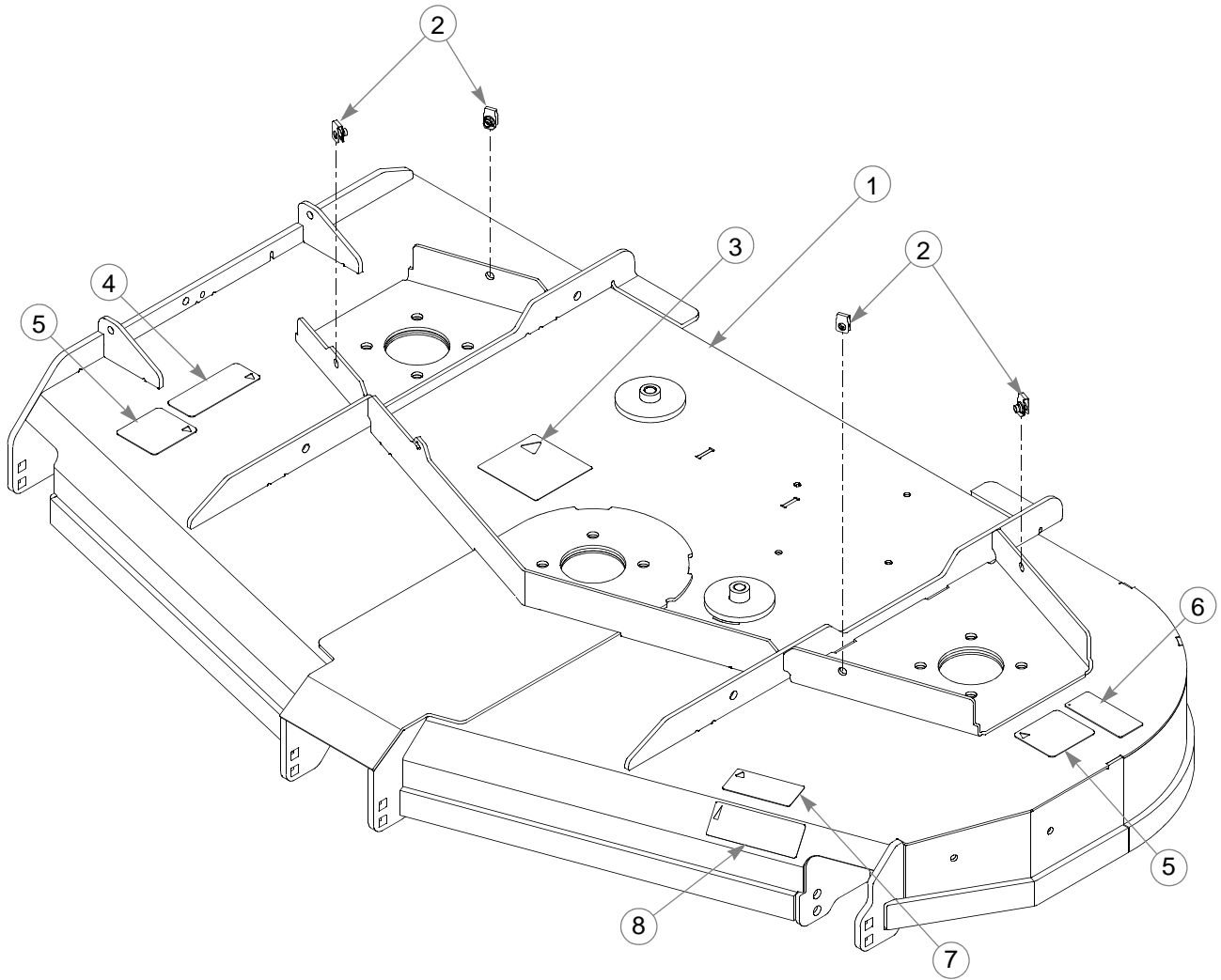

60" Side Discharge Service Deck

INDEX NO.	PART NO.	QTY.	DESCRIPTION
1	550739	1	60" VX4 DECK (WITH DECALS & HARDWARE)
2	601069	4	CN .312-18 X .20 MAX THK
3	781419	1	BELT ROUTING DECAL
4	601624	1	DISCHARGE CHUTE DECAL
5	601837	2	DECK DANGERS DECAL
6	601892	1	THROWN OBJECTS DECAL
7	786277	1	60" SD DECK ID DECAL
8	603092	1	VX4 TECHNOLOGY DECAL

NOTES:

60" Side Discharge Deck Pulleys & Spindles

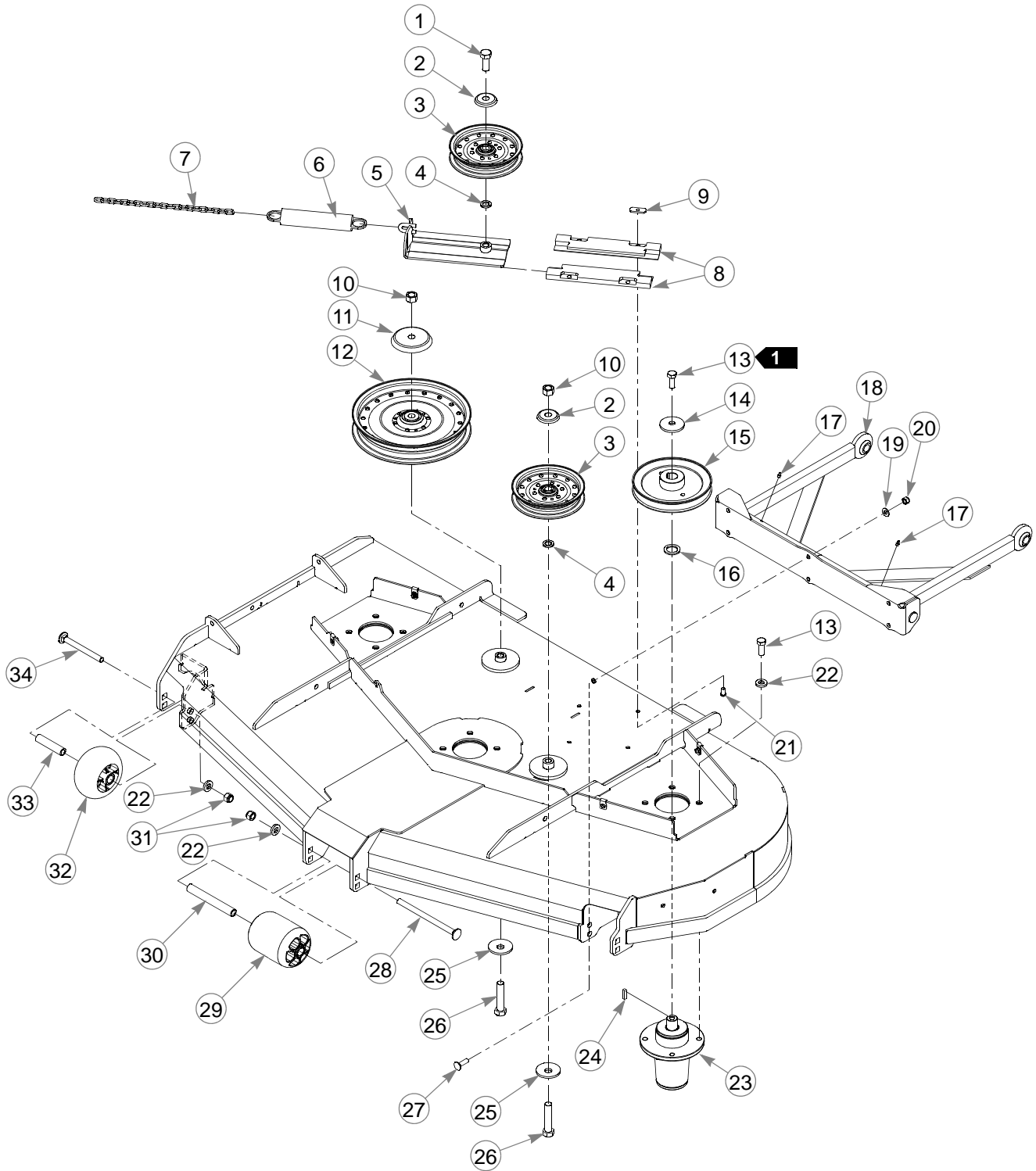

60" Side Discharge Deck Pulleys & Spindles

INDEX NO.	PART NO.	QTY.	DESCRIPTION
1	794446	1	CS .625-11 X 1.50 HX G5
2	602935	2	IDLER DUST SHIELD SM
3	602821	2	IDLER 6.0" RIVETED
4	028118	2	FW .625 X 1.00 X .134
5	350884	1	DECK IDLER SLIDE
6	781302	1	TENSION SPRING
7	373191	1	CHAIN, 21 LINK
8	602936	2	UHMW IDLER SLIDE
9	603023	4	WN .312-18 ZN
10	016972	2	NT .625-11 HX G5 ZNYC
11	602963	1	IDLER DUST SHIELD LG
12	602743	1	IDLER 10.0" RIVETED
13	705954	15	CS .500-13 X 1.25 HX G5
14	752386	3	CW .515 X 2.25 X .204 BLK
15	602745	3	PULLEY DRIVE 7.00 EFF
16	045765	3	FW 1.030 X 1.50 X .134
17	015495	2	GREASE FITTING STRAIGHT
18	113340	1	PUSHER
19	767954	6	FW .379 X .813 X .063
20	086660	6	NT .375-16 HX G5 NL
21	603022	4	CS .312-18 X .625 BH ZN
22	767962	15	FW .531 X 1.063 X .175
23	604255	3	BLADE SPINDLE CW
24	212472	3	KEY 1/4 SQ X 1.00
25	782474	2	CW .631 X 2.25 X .187 PNT
26	783738	2	CS .625-11 X 3.00 FULL HX G5
27	603113	6	CB .375-16 X 1.25 G5 ZN
28	602338	1	CB .500-13 X 7.50 STD ZN
29	602341	1	PLASTIC WHEEL
30	602344	1	SPACER 5.73
31	781567	3	NT .500-13 HX G8 ZY NL
32	602263	2	PLASTIC WHEEL
33	602345	2	SPACER 3.22
34	603049	2	CB .500-13 X 5.00 ZNYC

NOTES:

1. Torque to 67–75 ft-lbs.

60" Side Discharge Deck

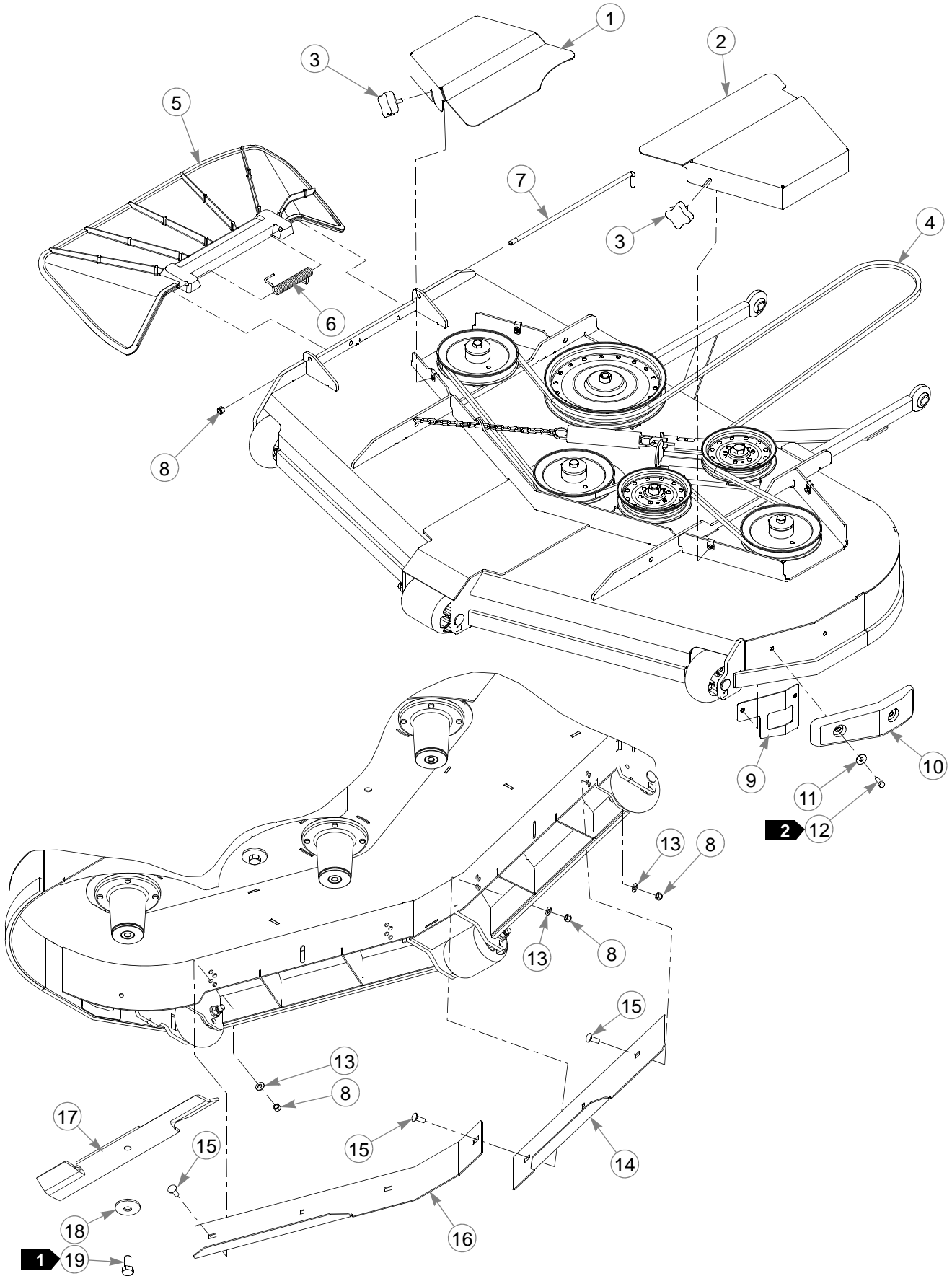

60" Side Discharge Deck

INDEX NO.	PART NO.	QTY.	DESCRIPTION
1	112933	1	RS PULLEY COVER
2	112934	1	LS PULLEY COVER
3	792002	4	KNOB 5/16-18 X 3/4"
4	604494	1	BELT, B-SEC 172" EL
5	602891	1	DISCHARGE CHUTE LG
6	602435	1	TORSION SPRING
7	602432	1	CHUTE PIN
8	086660	7	NT .375-16 HX G5 ZY NL
9	113563	1	BACKING PLATE
10	602817	1	RUBBER BUMPER
11	079210	2	FW .344 X 1.00 X .06 ZNYC
12	064014	2	CS .312-18 X .875 HX G5 ZN
13	767954	6	FW .379 X .813 X .063
14	113180	1	RS INNER WALL ADJ.
15	025395	6	CB .375-16 X 1.00 G5 ZNY
16	113179	1	LS INNER WALL ADJ.
17	602771	3	BLADE, F20.50" EHN-F-CW
	793794	3	BLADE, 20.50"-L-F-CW
	794214	3	BLADE, 20.50"-MUL-F-CW
	794230	3	BLADE, 20.50" -GAT-F-CW
	794685	3	BLADE, F20.50"-H-F-CW
18	782474	3	CW .631 X 2.25 X .187 PNT
19	781872	3	CS .625-11 X 1.25 HX G5 Z

NOTES:

1. Torque to 118 ft-lbs.
2. Torque to 10 ft-lbs.

66" Side Discharge Service Deck

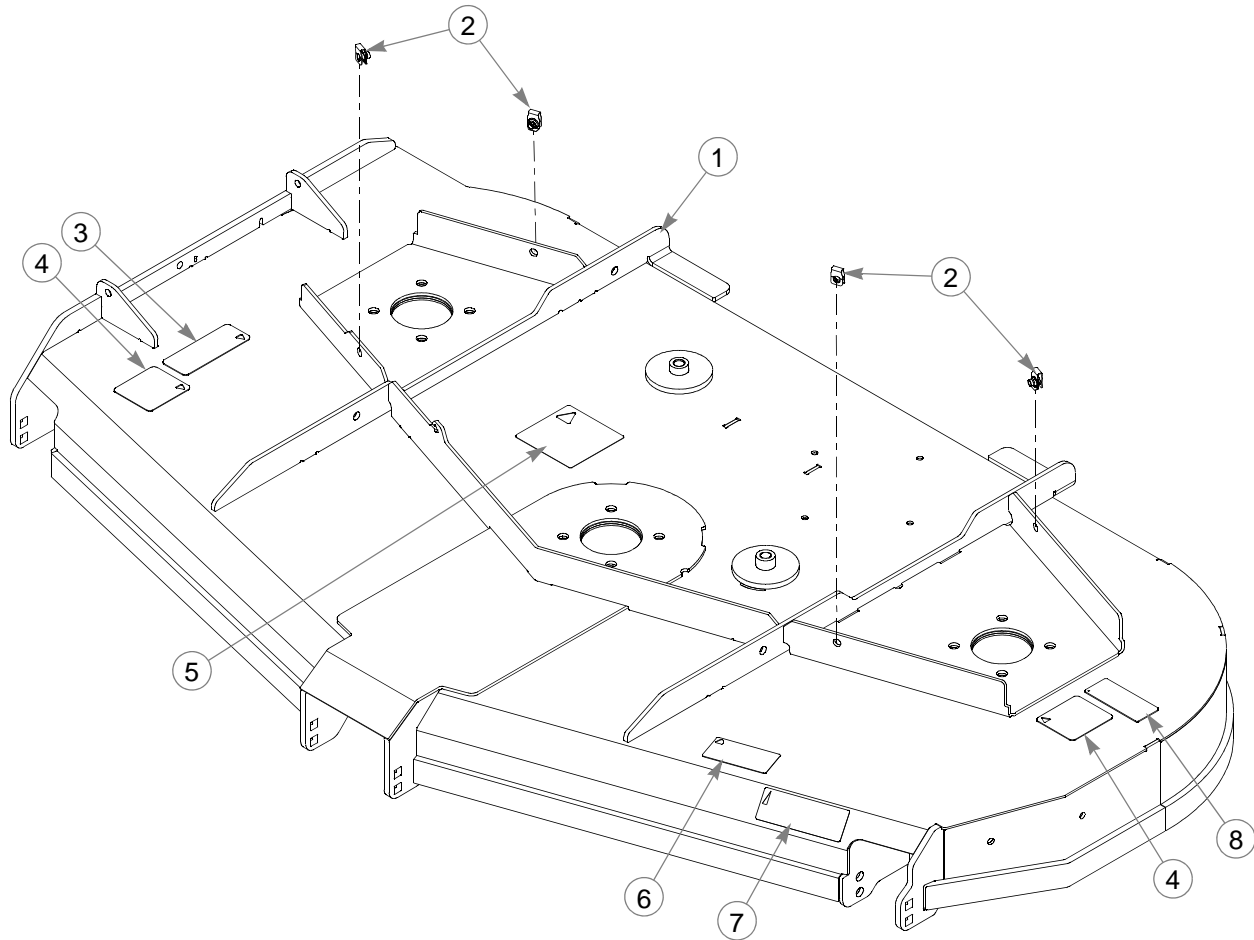

66" Side Discharge Service Deck

INDEX NO.	PART NO.	QTY.	DESCRIPTION
1	550750	1	66" VX4 DECK (WITH DECALS & HARDWARE)
2	601069	4	CN .312-18 X .20 MAX THK
3	601624	1	DISCHARGE CHUTE DECAL
4	601837	2	DECK DANGERS DECAL
5	781419	1	BELT ROUTING DECAL
6	799189	1	66" DECK ID DECAL
7	603092	1	VX4 TECHNOLOGY DECAL
8	601892	1	THROWN OBJECTS DECAL

NOTES:

66" Side Discharge Deck Pulleys & Spindles

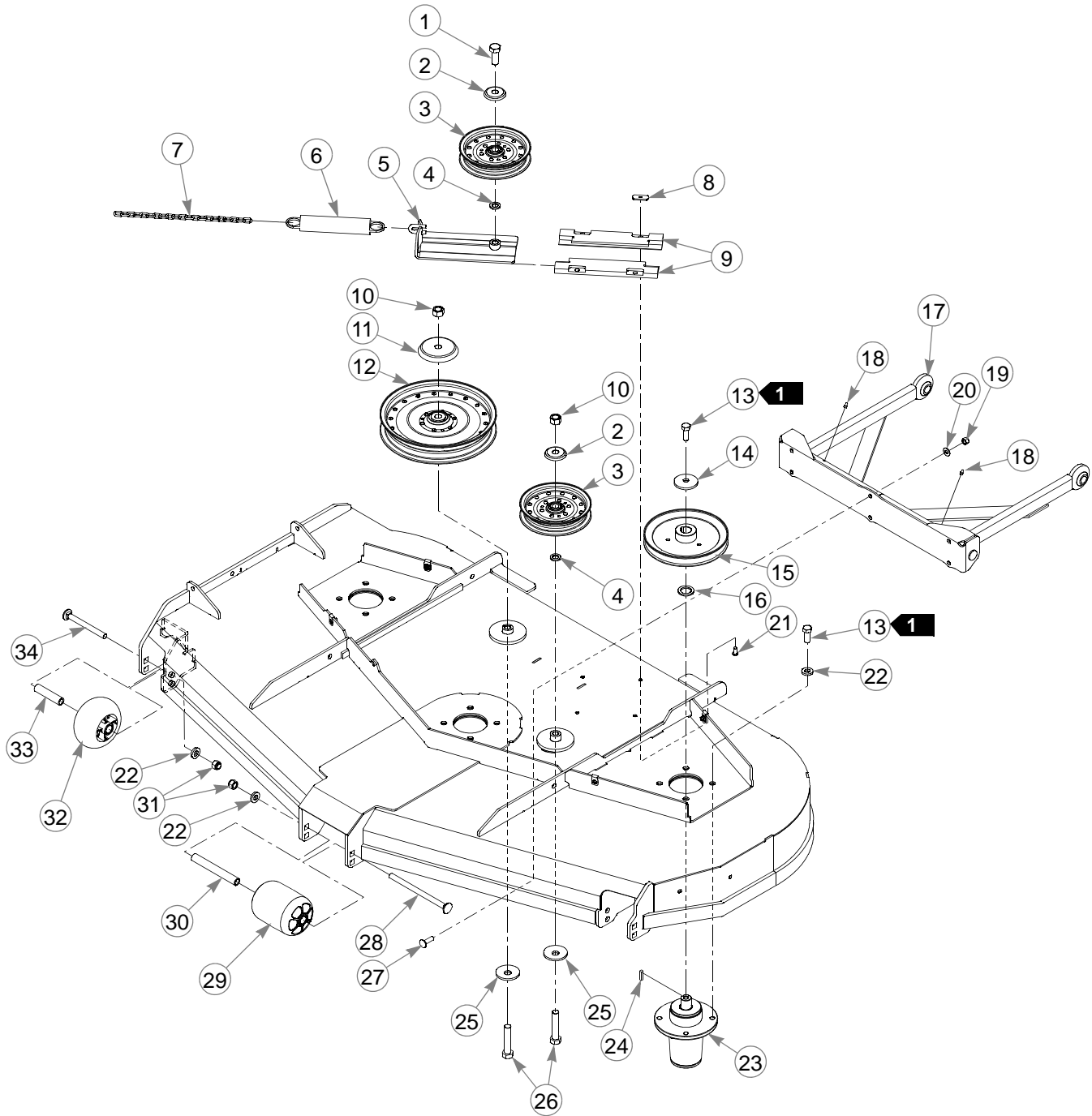

66" Side Discharge Deck Pulleys & Spindles

INDEX NO.	PART NO.	QTY.	DESCRIPTION
1	794446	1	CS .625-11 X 1.50 HX G5
2	602935	2	IDLER DUST SHIELD SM
3	602821	2	IDLER 6.0" RIVETED
4	028118	2	FW .625 X 1.00 X .134
5	350884	1	DECK IDLER SLIDE
6	781302	1	TENSION SPRING
7	373191	1	CHAIN, 21 LINK
8	603023	4	WN .312-18 ZN
9	602936	2	UHMW IDLER SLIDE
10	016972	2	NT .625-11 HX G5 ZNYC
11	602963	1	IDLER DUST SHIELD LG
12	602743	1	IDLER 10.0" RIVETED
13	705954	15	CS .500-13 X 1.25 HX G5
14	752386	3	CW .515 X 2.25 X .204 BLK
15	602859	3	DRIVE PULLEY 7.85 EFF
16	045765	3	FW 1.030 X 1.50 X .134
17	113340	1	PUSHER
18	015495	2	GREASE FITTING STRAIGHT
19	086660	6	NT .375-16 HX G5 NL
20	767954	6	FW .379 X .813 X .063
21	603022	4	CS .312-18 X .625 BH ZN
22	767962	15	FW .531 X 1.063 X .175
23	604255	3	BLADE SPINDLE CW
24	212472	3	KEY 1/4 SQ X 1.00
25	782474	2	CW .631 X 2.25 X .187 PNT
26	783738	2	CS .625-11 X 3.00 FULL HX G5
27	603113	6	CB .375-16 X 1.25 G5 ZN
28	602338	1	CB .500-13 X 7.50 STD ZN
29	602341	1	PLASTIC WHEEL
30	602344	1	SPACER 5.73
31	781567	3	NT .500-13 HX G8 ZY NL
32	602263	2	PLASTIC WHEEL
33	602345	2	SPACER 3.22
34	603049	2	CB .500-13 X 5.00 ZNYC

NOTES:

1. Torque to 67–75 ft-lbs

66" Side Discharge Deck

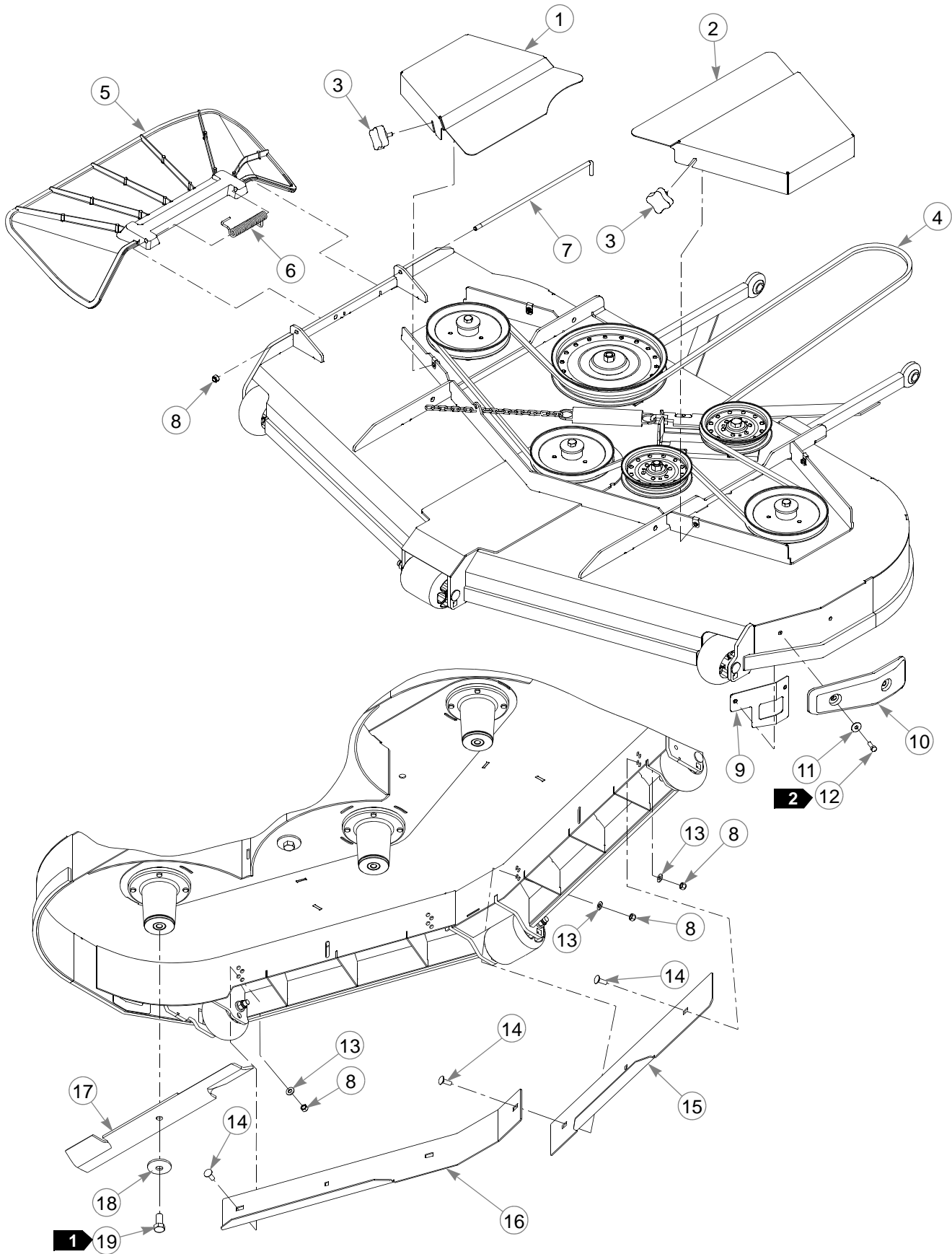

66" Side Discharge Deck

INDEX NO.	PART NO.	QTY.	DESCRIPTION
1	113335	1	RS PULLEY COVER
2	113336	1	LS PULLEY COVER
3	792002	4	KNOB 5/16-18 X 3/4"
4	602854	1	BELT, B-SEC
5	602891	1	DISCHARGE CHUTE LG
6	602435	1	TORSION SPRING
7	602432	1	CHUTE PIN
8	086660	7	NT .375-16 HX G5 ZY NL
9	113563	1	BACKING PLATE
10	602817	1	RUBBER BUMPER
11	079210	2	FW .344 X 1.00 X .06 ZNYC
12	064014	2	CS .312-18 X .875 HX G5 ZN
13	767954	6	FW .379 X .813 X .063
14	025395	6	CB .375-16 X 1.00 G5 ZNY
15	113333	1	RS INNER WALL ADJ.
16	113334	1	LS INNER WALL ADJ.
17	602864	3	BLADE, F22.50" EHN-F-CW
	798496	3	BLADE, F22.50" -H-F-CW
	798512	3	BLADE, 22.50" -GAT-F-CW
	798504	3	BLADE, 22.50" -MUL-F-CW
18	782474	3	CW .631 X 2.25 X .187 PNT
19	781872	3	CS .625-11 X 1.25 HX G5 Z

NOTES:

1. Torque to 118 ft-lbs.
2. Torque to 10 ft-lbs.

72" Side Discharge Service Deck

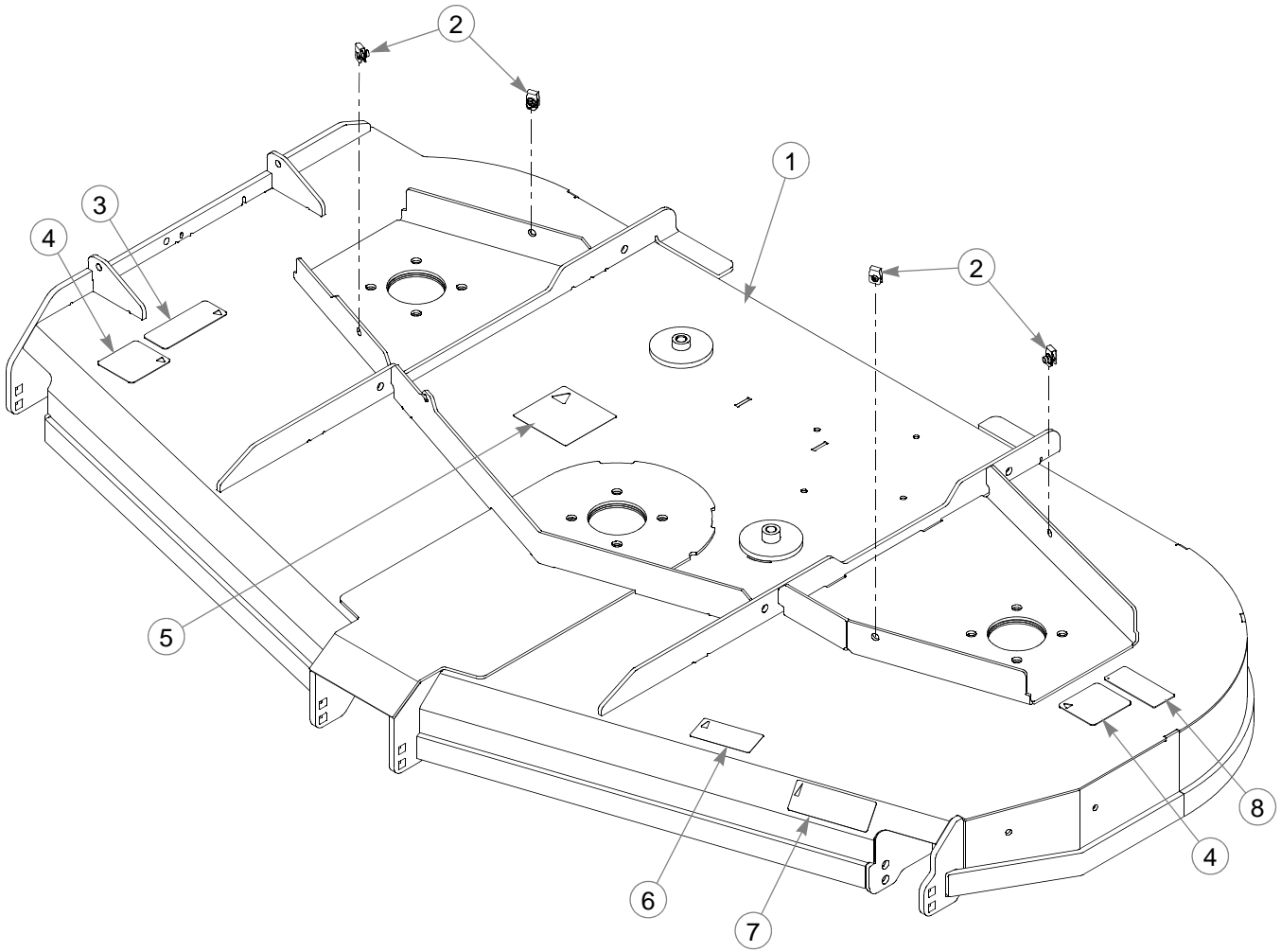

72" Side Discharge Service Deck

INDEX NO.	PART NO.	QTY.	DESCRIPTION
1	550751	1	72" VX4 DECK (WITH DECALS & HARDWARE)
2	601069	4	CN .312-18 X .20 MAX THK
3	601624	1	DISCHARGE CHUTE DECAL
4	601837	2	DECK DANGERS DECAL
5	781419	1	BELT ROUTING DECAL
6	786285	1	72" DECK ID DECAL
7	603092	1	VX4 TECHNOLOGY DECAL
8	601892	1	THROWN OBJECTS DECAL

NOTES:

72" Side Discharge Deck Pulleys & Spindles

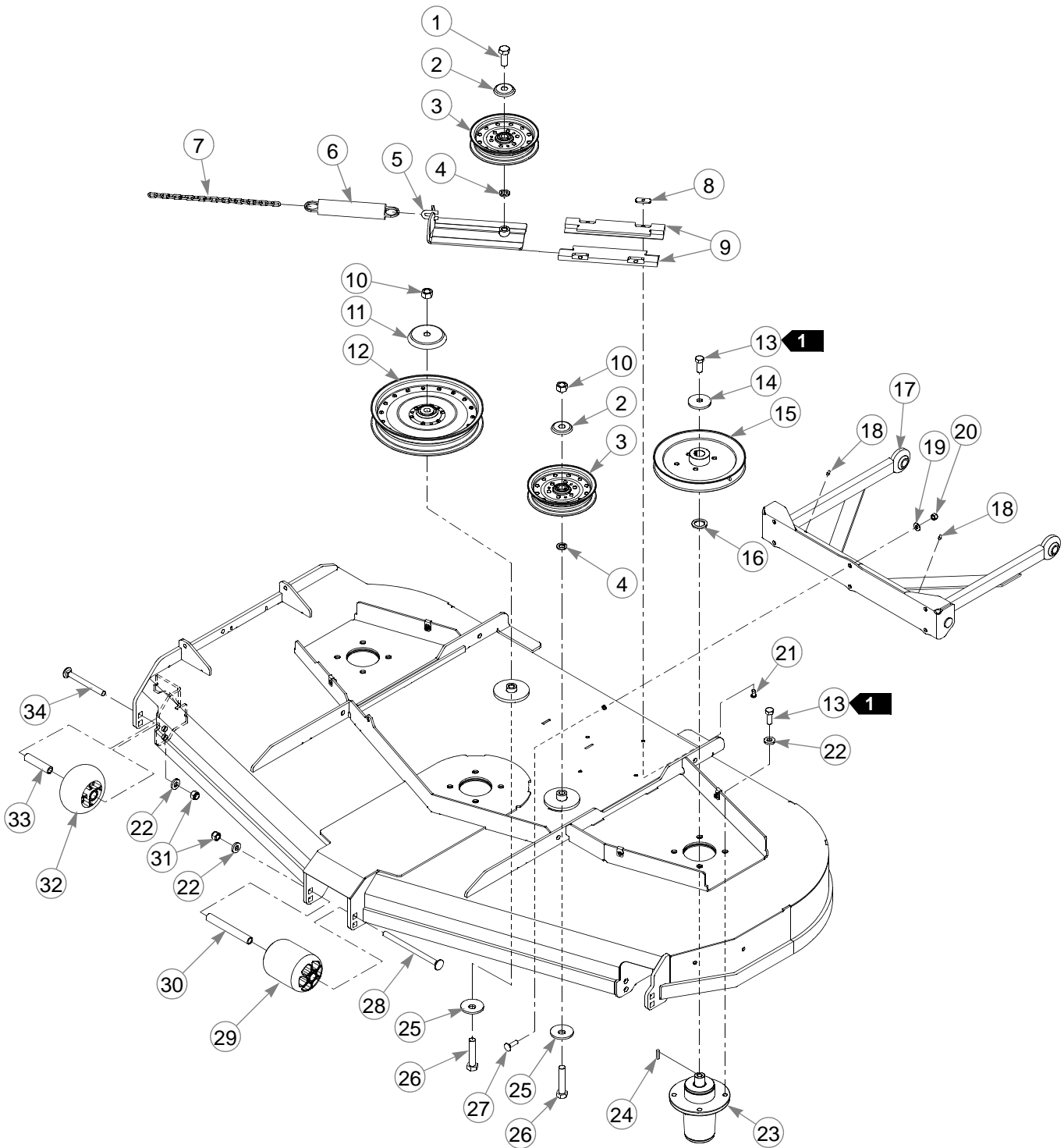

72" Side Discharge Deck Pulleys & Spindles

INDEX NO.	PART NO.	QTY.	DESCRIPTION
1	794446	1	CS .625-11 X 1.50 HX G5
2	602935	2	IDLER DUST SHIELD SM
3	602821	2	IDLER 6.0" RIVETED
4	028118	2	FW .625 X 1.00 X .134
5	350884	1	DECK IDLER SLIDE
6	781302	1	TENSION SPRING
7	373191	1	CHAIN, 21 LINK
8	603023	4	WN .312-18 ZN
9	602936	2	UHMW IDLER SLIDE
10	016972	2	NT .625-11 HX G5 ZNYC
11	602963	1	IDLER DUST SHIELD LG
12	602743	1	IDLER 10.0" RIVETED
13	705954	15	CS .500-13 X 1.25 HX G5
14	752386	3	CW .515 X 2.25 X .204 BLK
15	602746	3	DRIVE PULLEY 8.652 OP
16	045765	3	FW 1.030 X 1.50 X .134
17	113340	1	PUSHER
18	015495	2	GREASE FITTING STRAIGHT
19	767954	6	FW .379 X .813 X .063
20	086660	6	NT .375-16 HX G5 NL
21	603022	4	CS .312-18 X .625 BH ZN
22	767962	15	FW .531 X 1.063 X .175
23	604255	3	BLADE SPINDLE CW (S/N 12092683 & HIGHER)
	601630	3	BLADE SPINDLE CW (S/N PRIOR TO 12092683)
24	212472	3	KEY 1/4 SQ X 1.00
25	782474	2	CW .631 X 2.25 X .187 PNT
26	783738	2	CS .625-11 X 3.00 FULL HX G5
27	603113	6	CB .375-16 X 1.25 G5 ZN
28	602338	1	CB .500-13 X 7.50 STD ZN
29	602341	1	PLASTIC WHEEL
30	602344	1	SPACER 5.73
31	781567	3	NT .500-13 HX G8 ZY NL
32	602263	2	PLASTIC WHEEL
33	602345	2	SPACER 3.22
34	603049	2	CB .500-13 X 5.00 ZNYC

NOTES:

1. Torque to 67–75 ft-lbs.

72" Side Discharge Deck

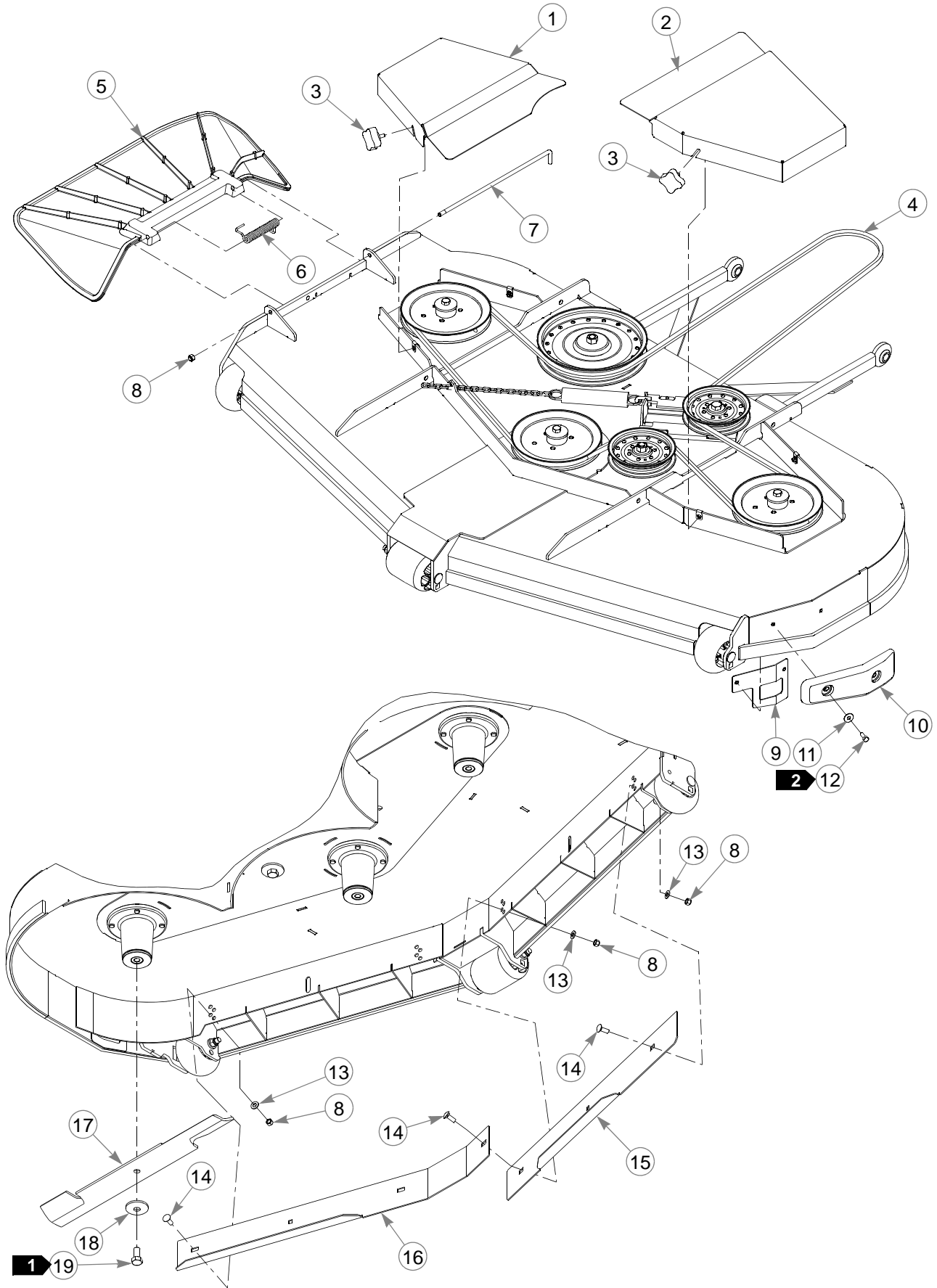

72" Side Discharge Deck

INDEX NO.	PART NO.	QTY.	DESCRIPTION
1	112935	1	RS PULLEY COVER
2	112936	1	LS PULLEY COVER
3	792002	4	KNOB 5/16-18 X 3/4"
4	784207	1	BELT, B 195" EL
5	602891	1	DISCHARGE CHUTE LG
6	602435	1	TORSION SPRING
7	602432	1	CHUTE PIN
8	086660	7	NT .375-16 HX G5 ZY NL
9	113563	1	BACKING PLATE
10	602817	1	RUBBER BUMPER
11	079210	2	FW .344 X 1.00 X .06 ZNYC
12	064014	2	CS .312-18 X .875 HX G5 ZN
13	767954	6	FW .379 X .813 X .063
14	025395	6	CB .375-16 X 1.00 G5 ZNY
15	112931	1	RS INNER WALL ADJ.
16	112932	1	LS INNER WALL ADJ.
17	602857	3	BLADE, F24.50" -EHN-F-CW
	798702	3	BLADE, F24.50" -H-F-CW
	798710	3	BLADE, 24.50" -MUL-F-CW
	798728	3	BLADE, 24.50" -GAT-F-CW
18	782474	3	CW .631 X 2.25 X .187 PNT
19	781872	3	CS .625-11 X 1.25 HX G5 Z

NOTES:

1. Torque to 118 ft-lbs.
2. Torque to 10 ft-lbs.

60" Rear Discharge Service Deck

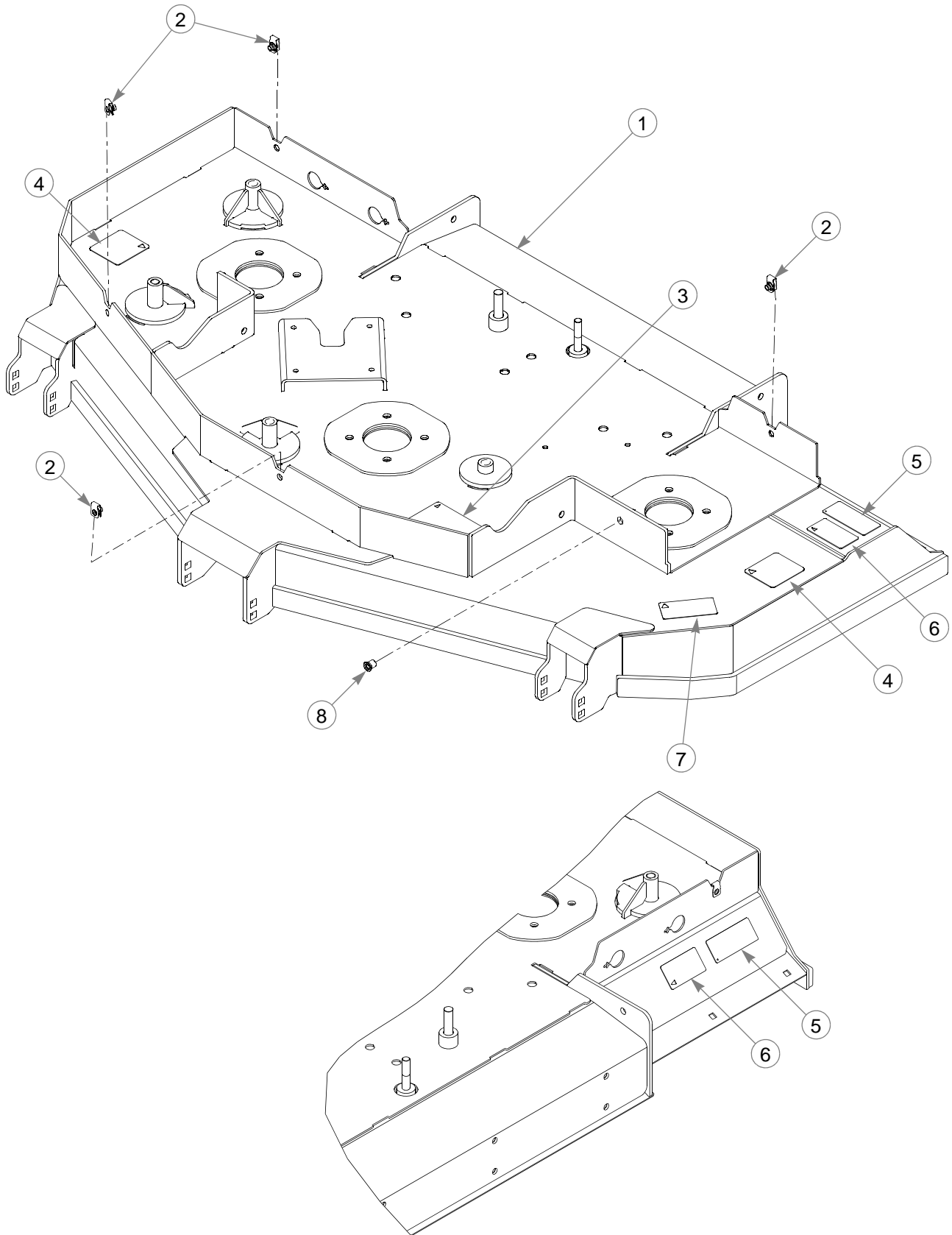

60" Rear Discharge Service Deck

INDEX NO.	PART NO.	QTY.	DESCRIPTION
1	550935	1	60" RD DECK (WITH DECALS & HARDWARE)
2	601069	4	CN .312-18 X .20 MAX THK
3	603349	1	2 BELT ROUTING DECAL
4	601837	2	DECK DANGERS DECAL
5	601892	2	THROWN OBJECTS DECAL
6	603391	2	RUBBER FLAP DECAL
7	786277	1	60" DECK ID DECAL
8	792887	1	5/16-18 THREAD HEX RIVET NUT

NOTES:

60" Rear Discharge Deck Pulleys & Spindles

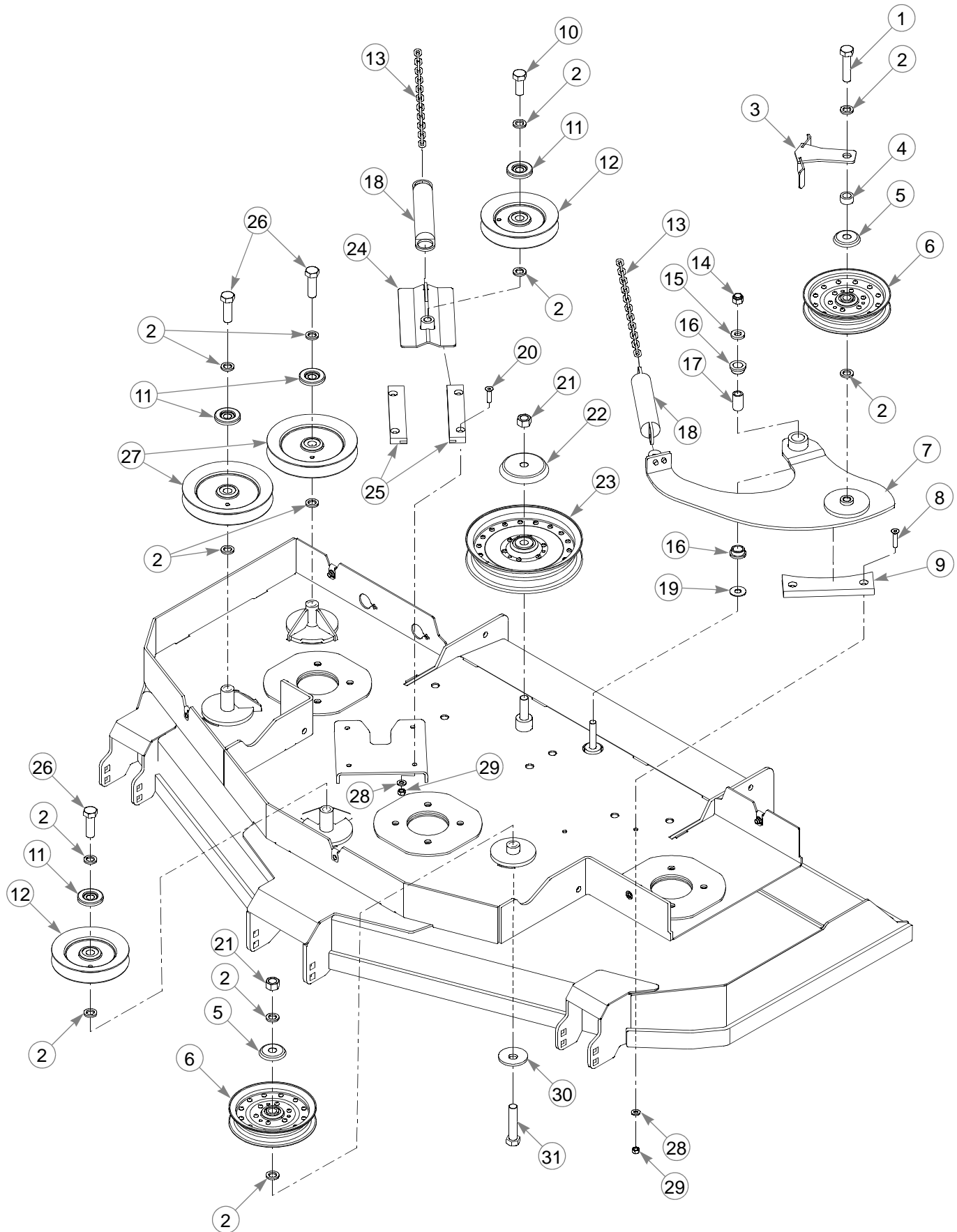

60" Rear Discharge Deck Pulleys & Spindles

INDEX NO.	PART NO.	QTY.	DESCRIPTION
1	025015	1	CS .625-11 X 2.50 HX G5
2	028118	12	FW .625 X 1.00 X .134
3	113088	1	BELT GUIDE
4	603256	1	DECK IDLER SPACER 1/2" LG
5	602935	2	IDLER DUST SHIELD SM
6	602821	2	IDLER 6.0" RIVETED
7	114133	1	RD DECK IDLER ARM
8	797910	2	CS .312-18 X 1.50 FLT SH ZY
9	601779	1	IDLER GUIDE
10	794446	1	CS .625-11 X 1.50 HX G5
11	603057	4	DUST SHIELD WITH OFFSET
12	602672	2	PULLEY V-IDLER HBB 5.0"
13	373191	2	CHAIN, 21 LINK
14	781567	1	NT .500-13 HX G8 ZY NL
15	767962	13	FW .531 X 1.063 X .175
16	770867	2	PLASTIC BUSHING .750 X 1
17	109549	1	IDLER PIVOT BUSHING
18	781302	2	TENSION SPRING
19	704759	1	FW .500 X 1.25 X .075 ZNY
20	784199	4	CS .312-18 X 1.25 FLT SH
21	016972	2	NT .625-11 HX G5 ZNYC
22	602963	1	IDLER DUST SHIELD LG
23	602838	1	IDLER 8.0" RIVETED
24	114105	1	IDLER SLIDE
25	601619	2	IDLER SLIDE UHMW
26	016642	3	CS .625-11 X 2.00 HX G5 Z
27	796714	2	6" HB IDLER PULLEY
28	768523	6	FW .343 X .687 X .051/.080H
29	058776	6	NT .312-18 HX G5 ZY NL
30	782474	1	CW .631 X 2.25 X .187 PNT
31	783738	1	CS .625-11 X 3.00 FULL HX G5

NOTES:

60" Rear Discharge Deck Pulleys & Spindles

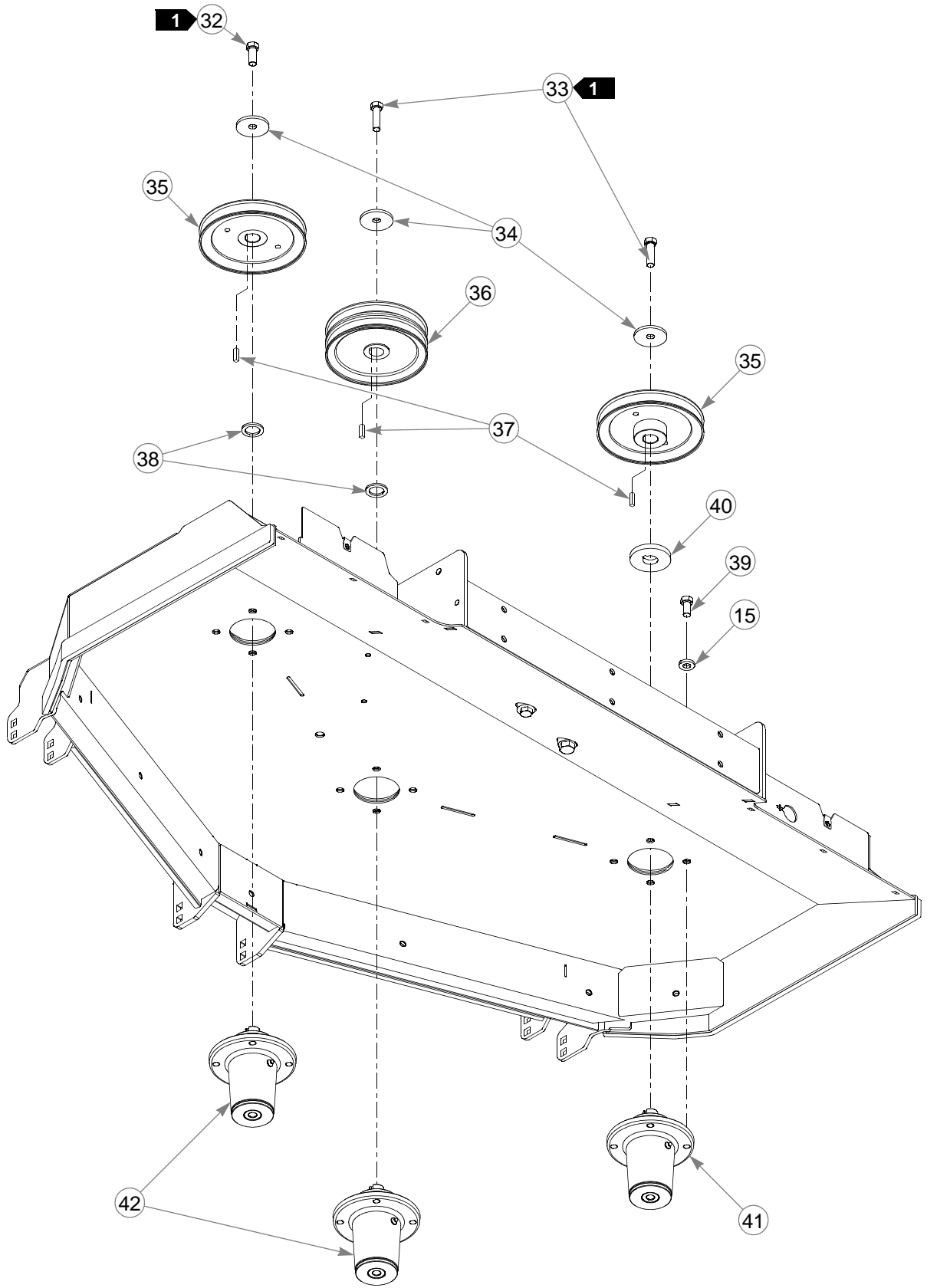

60" Rear Discharge Deck Pulleys & Spindles

INDEX NO.	PART NO.	QTY.	DESCRIPTION
32	705954	1	CS .500-13 X 1.25 HX G5
33	017616	2	CS .500-13 X 1.75 HX G5
34	752386	3	CW .515 X 2.25 X .204 BLK
35	602745	2	PULLEY DRIVE 7.00 EFF
36	770388	1	PULLEY
37	212472	3	KEY 1/4 SQ X 1.00
38	045765	2	FW 1.030 X 1.50 X .134
39	016527	12	CS .500-13 X 1.00 HX G5 ZN
40	114108	1	SPACER
41	604256	1	BLADE SPINDLE CCW (S/N 12092683 & HIGHER)
	601819	1	BLADE SPINDLE CCW (S/N PRIOR TO 12092683)
42	604255	2	BLADE SPINDLE CW (S/N 12092683 & HIGHER)
	601630	2	BLADE SPINDLE CW (S/N PRIOR TO 12092683)

NOTES:

1. Torque to 65–75 ft-lbs.

60" Rear Discharge Dust Shield

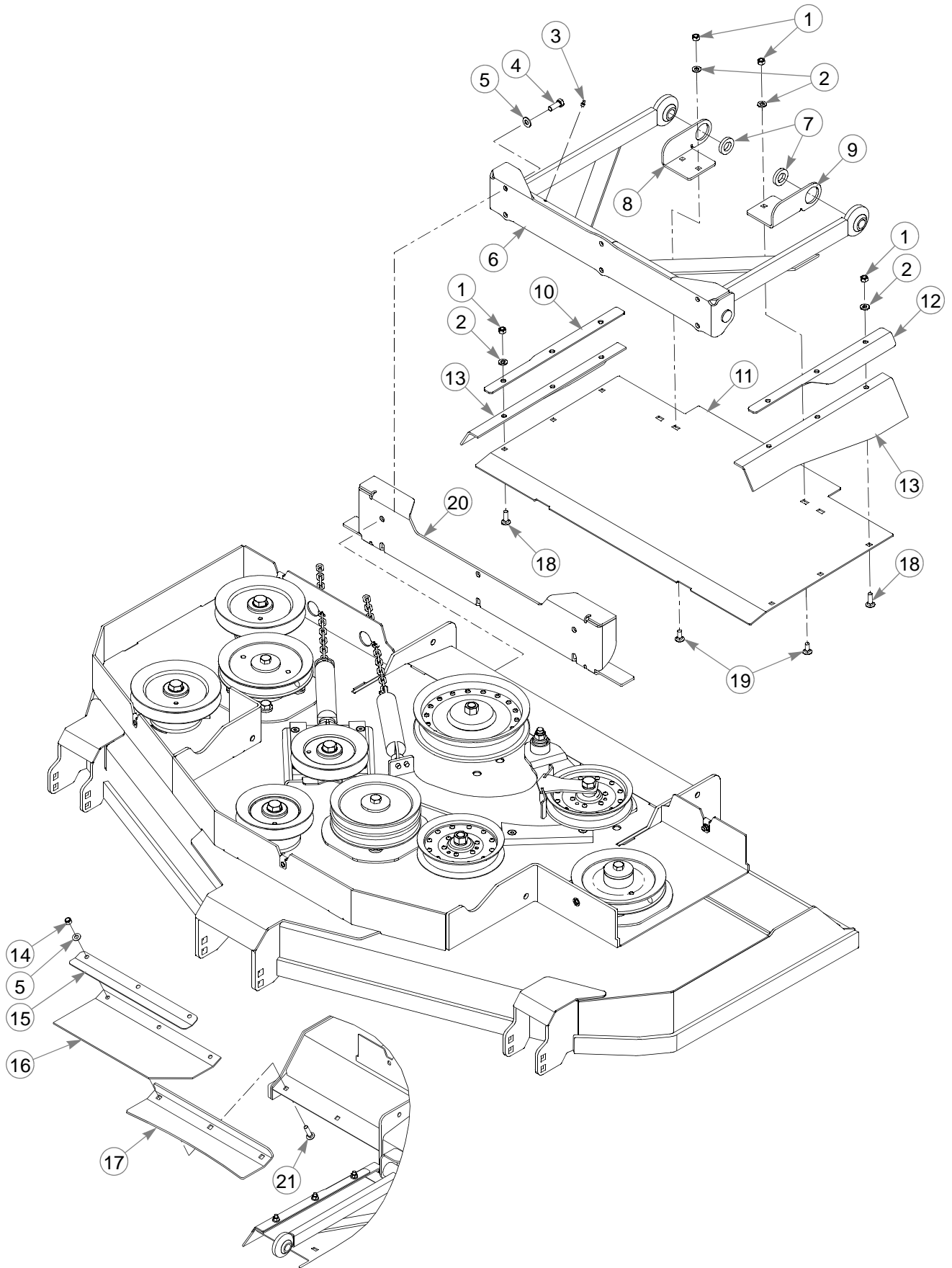

60" Rear Discharge Dust Shield

INDEX NO.	PART NO.	QTY.	DESCRIPTION
1	058776	10	NT .312-18 HX G5 ZY
2	768523	10	FW .343 X .687 X .051/.080H
3	015495	2	GREASE FITTING STRAIGHT
4	036244	6	CS .375-16 X 1.00 HX G5
5	767954	12	FW .379 X .813 X .063
6	113340	1	PUSHER
7	778399	2	FW .781 X 1.375 X .250 ZNY
8	109482	1	RS CHUTE BRACKET
9	109483	1	LS CHUTE BRACKET
10	109487	1	RS CLAMP ANGLE
11	114440	1	DUST SHIELD
12	109486	1	LS CLAMP ANGLE
13	601483	2	RUBBER SIDE FLAP
14	086660	6	NT .375-16 HX G5 ZY NL
15	106716	2	DISCHARGE CHUTE ANGLE
16	600254	2	RD REAR FLAP
17	351676	2	DECK STIFFENER ANGLE
18	037887	6	CB .312-18 X 1.00 FULL ZN
19	016253	4	CB .312-18 X .75 FUL ZN
20	114522	1	REAR DECK STOP
21	710194	6	CB .375-16 X 1.50 STD G5

NOTES:

60" Rear Discharge Deck

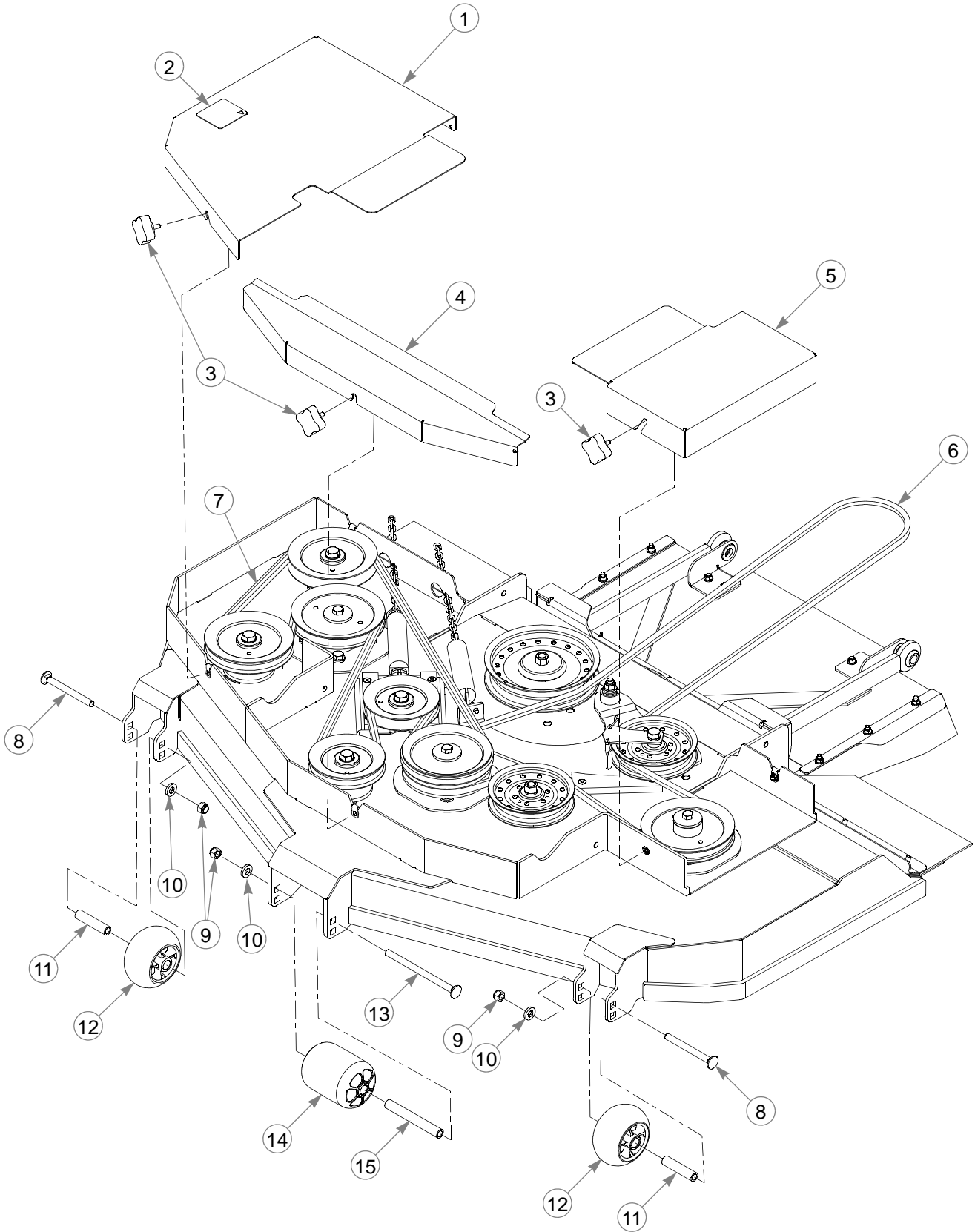

60" Rear Discharge Deck

INDEX NO.	PART NO.	QTY.	DESCRIPTION
1	550939	1	RS PULLEY COVER (WITH DECALS)
2	601837	1	DECK DANGERS DECAL
3	792002	5	KNOB 5/16-18 X 3/4"
4	550938	1	CENTER PULLEY COVER
5	114210	1	LS PULLEY COVER
6	777185	1	BELT, B 145.5" EL
7	027284	1	BELT, B 138" EL
8	603049	2	CB .500-13 X 5.00 ZNYC
9	781567	3	NT .500-13 HX G8 ZY NL
10	767962	3	FW .531 X 1.063 X .175
11	602345	2	SPACER 3.22
12	602263	2	PLASTIC WHEEL
13	602338	1	CB .500-13 X 7.50 STD ZN
14	602341	1	PLASTIC WHEEL
15	602344	1	SPACER 5.73

NOTES:

60" Rear Discharge Deck

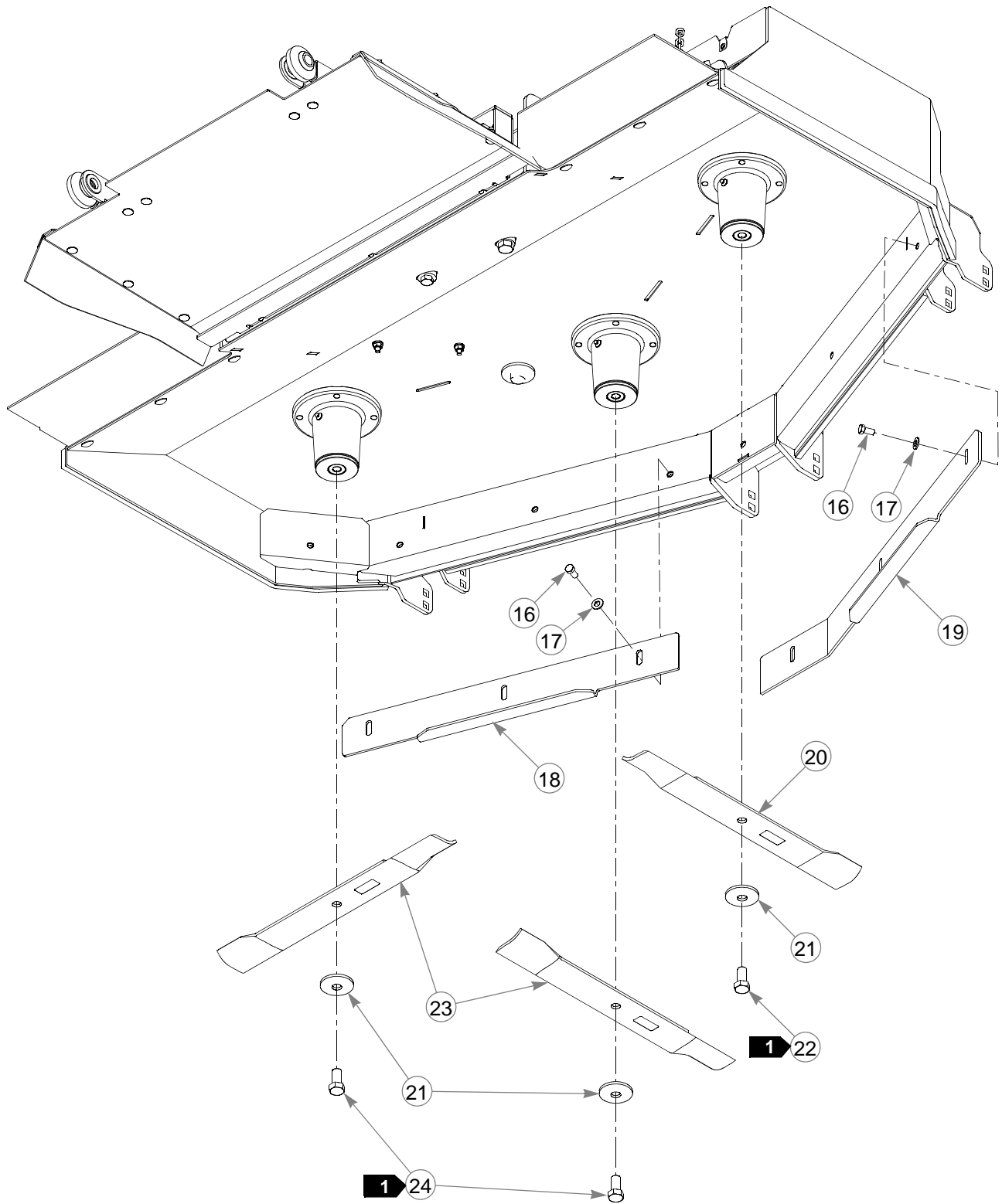

60" Rear Discharge Deck

INDEX NO.	PART NO.	QTY.	DESCRIPTION
16	055822	6	CS .375-16 X .75 HX G5
17	767954	6	FW .379 X .813 X .063
18	114205	1	LS ADJUSTABLE BAFFLE
19	114204	1	RS ADJUSTABLE BAFFLE
20	795633	1	BLADE, F20.50"-L-F-CCW
	601928	1	BLADE, 20.50" GAT-F-CCW
21	782474	3	CW .631 X 2.25 X .187 PNT
22	604383	1	CS .625-11 X 1.25 HX G5 LH THREAD
23	600901	2	BLADE, F20.50"-L-F-CW
	794230	2	BLADE, 20.50" GAT-F-CW
24	781872	2	CS .625-11 X 1.25 HX G5 Z

NOTES:

1. Torque to 118 ft-lbs.

72" Rear Discharge Service Deck

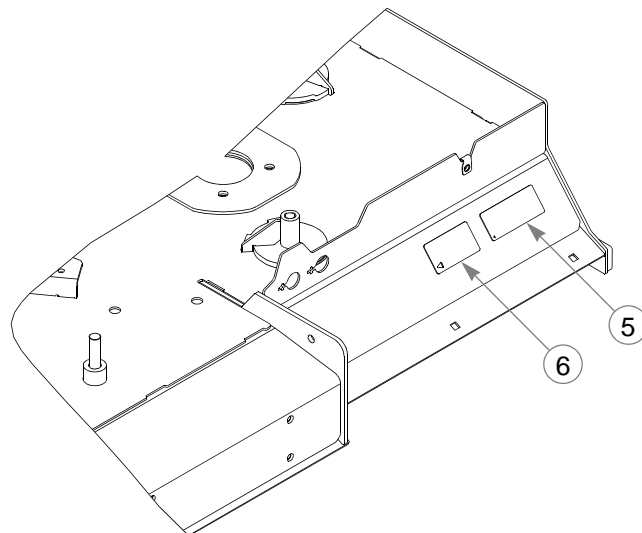
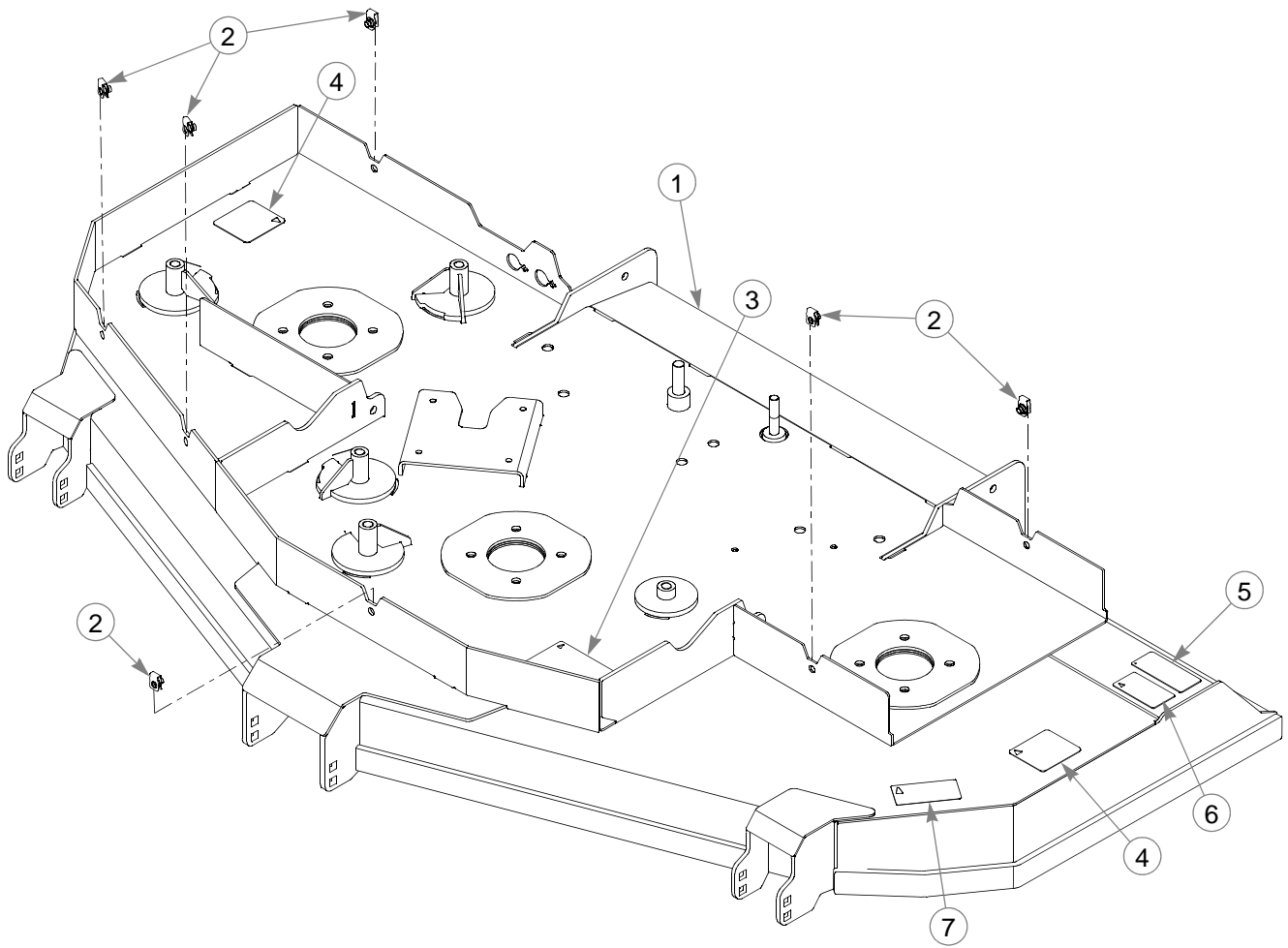

72" Rear Discharge Service Deck

INDEX NO.	PART NO.	QTY.	DESCRIPTION
1	551049	1	72" RD DECK (WITH DECALS & HARDWARE)
2	601069	6	CN .312-18 X .20 MAX THK
3	603349	1	2 BELT ROUTING DECAL
4	601837	2	DECK DANGERS DECAL
5	601892	2	THROWN OBJECTS DECAL
6	603391	2	RUBBER FLAP DECAL
7	786285	1	72" DECK ID DECAL

NOTES:

72" Rear Discharge Deck Pulleys & Spindles

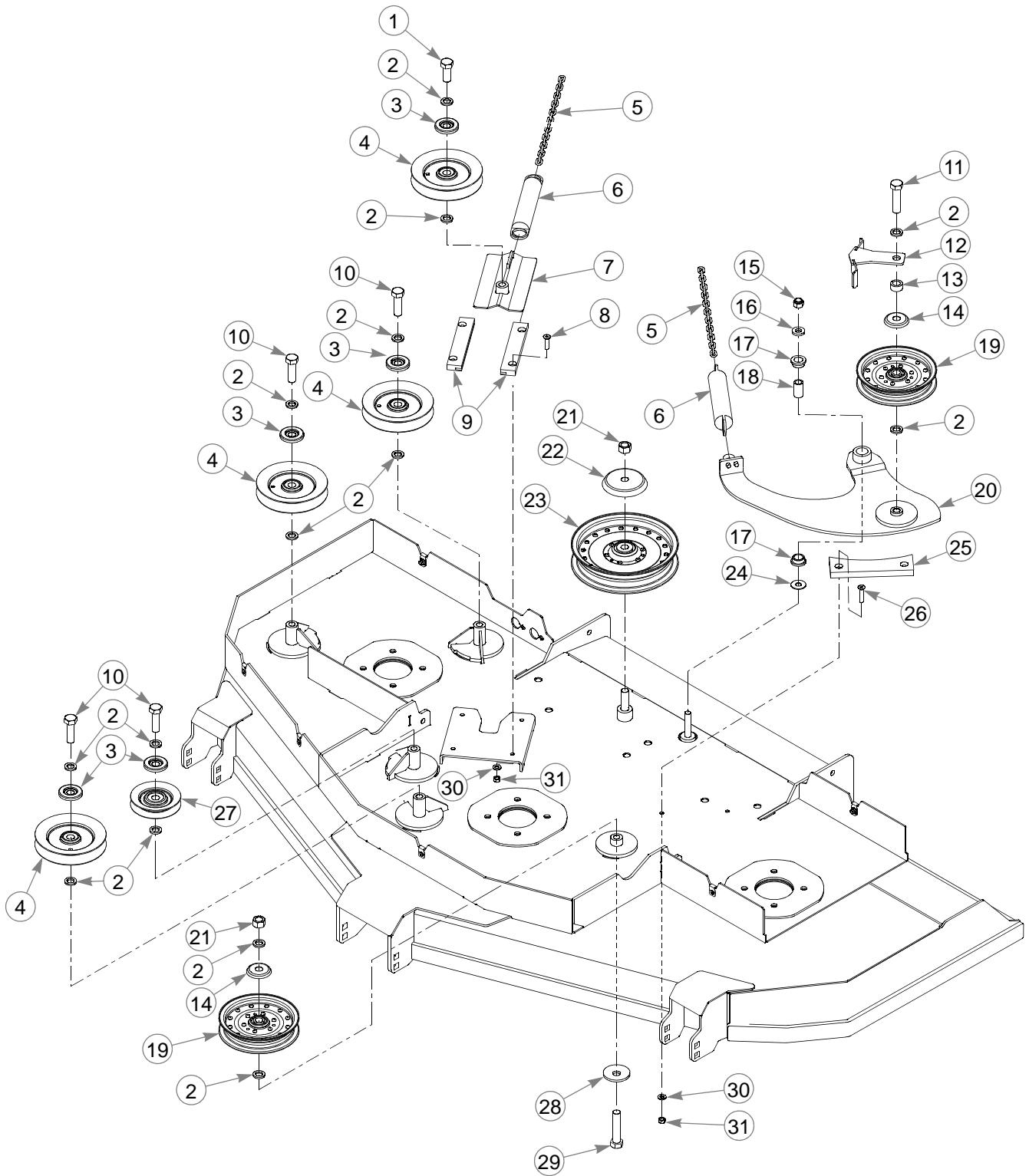

72" Rear Discharge Deck Pulleys & Spindles

INDEX NO.	PART NO.	QTY.	DESCRIPTION
1	794446	1	CS .625-11 X 1.50 HX G5
2	028118	14	FW .625 X 1.00 X .134
3	603057	5	DUST SHIELD WITH OFFSET
4	602672	4	PULLEY V-IDLER HBB 5.0"
5	373191	2	CHAIN, 21 LINK
6	781302	2	TENSION SPRING
7	114105	1	IDLER SLIDE
8	784199	4	CS .312-18 X 1.25 FLT SH
9	601619	2	IDLER SLIDE UHMW
10	016642	4	CS .625-11 X 2.00 HX G5 Z
11	025015	1	CS .625-11 X 2.50 HX G5
12	113088	1	BELT GUIDE
13	603256	1	DECK IDLER SPACER 1/2" LG
14	602935	2	IDLER DUST SHIELD SM
15	781567	1	NT .500-13 HX G8 ZY NL
16	767962	13	FW .531 X 1.063 X .175
17	770867	2	BUSHING
18	109549	1	BUSHING
19	602821	2	IDLER 6.0" RIVETED
20	114133	1	RD DECK IDLER ARM
21	016972	2	NT .625-11 HX G5 ZNYC
22	602963	1	IDLER DUST SHIELD LG
23	602838	1	IDLER 8.0" RIVETED
24	704759	1	FW .500 X 1.25 X .075 ZNY
25	601779	1	IDLER GUIDE
26	797910	2	CS .312-18 X 1.50 FLT SH ZY
27	788364	1	IDLER PULLEY NHI 4.288"
28	782474	1	CW .631 X 2.25 X .187 PNT
29	783738	1	CS .625-11 X 3.00 FULL HX G5
30	768523	6	FW .343 X .687 X .051/.080H
31	058776	6	NT .312-18 HX G5 ZY NL

NOTES:

72" Rear Discharge Deck Pulleys & Spindles

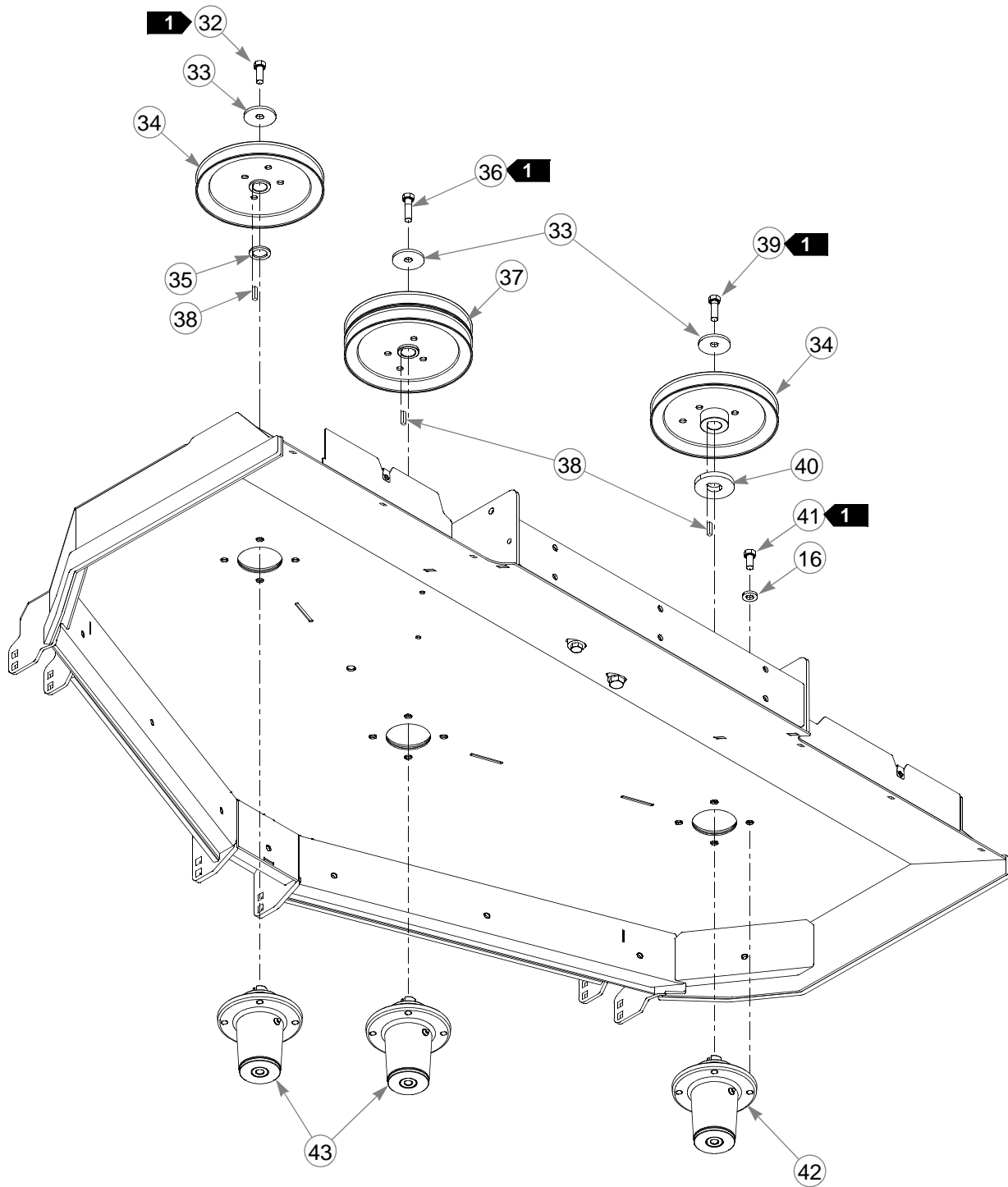

72" Rear Discharge Deck Pulleys & Spindles

INDEX NO.	PART NO.	QTY.	DESCRIPTION
32	705954	1	CS .500-13 X 1.25 HX G5
33	752386	3	CW .515 X 2.25 X .204 BLK
34	602746	2	DRIVE PULLEY 8.652 OP
35	045765	1	FW 1.030 X 1.50 X .134
36	017616	1	CS .500-13 X 1.75 HX G5
37	603226	1	DOUBLE PULLEY 8.41"
38	212472	3	KEY 1/4 SQ X 1.00
39	074252	1	CS .500-13 X 1.50 HX G5
40	114108	1	SPACER
41	016527	12	CS .500-13 X 1.00 HX G5 ZN
42	604256	1	BLADE SPINDLE CCW (S/N 12092683 & HIGHER)
	601819	1	BLADE SPINDLE CCW (S/N PRIOR TO 12092683)
43	604255	2	BLADE SPINDLE CW (S/N 12092683 & HIGHER)
	601630	2	BLADE SPINDLE CW (S/N PRIOR TO 12092683)

NOTES:

1. Torque to 65–75 ft-lbs.

72" Rear Discharge Dust Shield

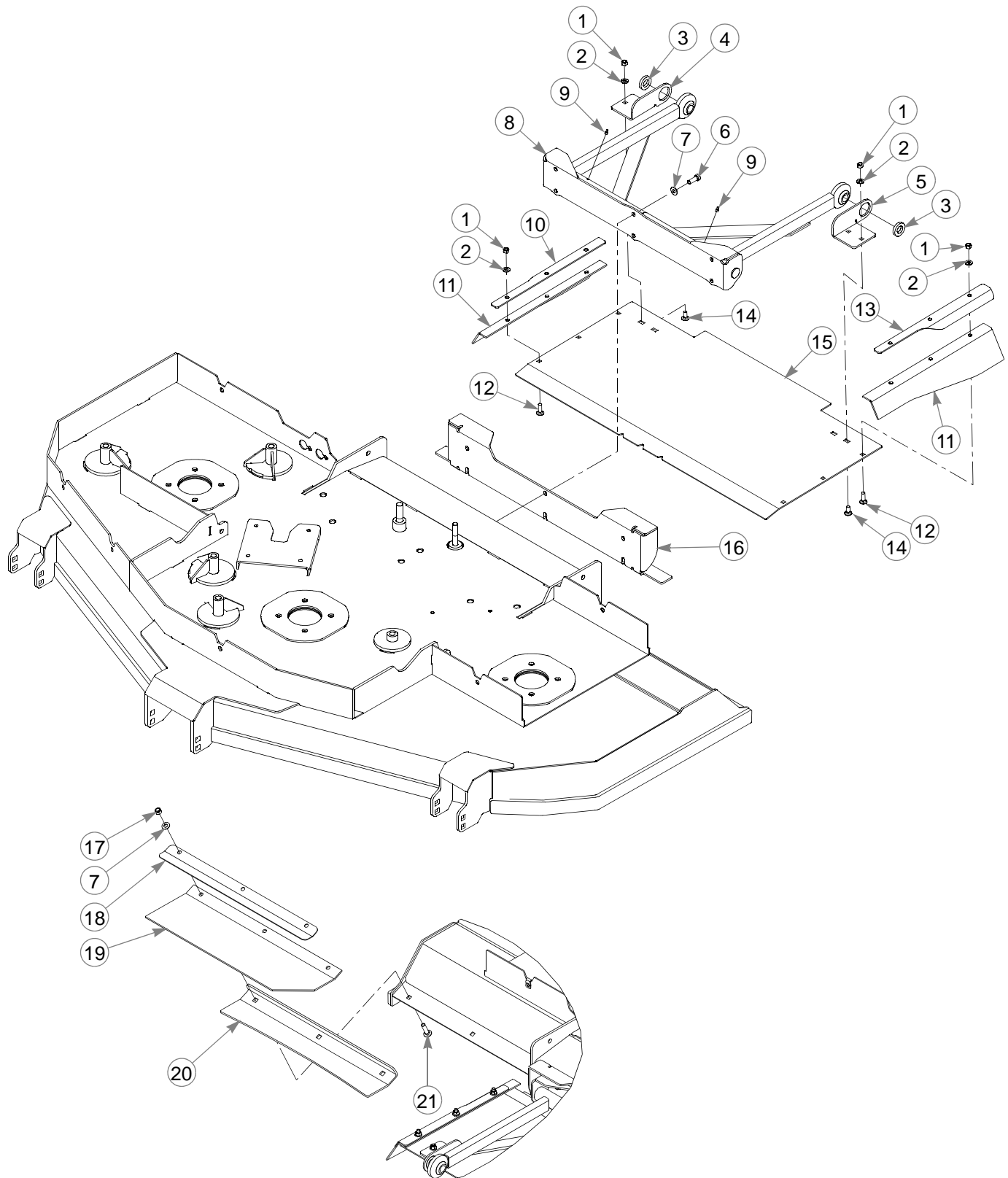

72" Rear Discharge Dust Shield

INDEX NO.	PART NO.	QTY.	DESCRIPTION
1	058776	10	NT .312-18 HX G5 ZY NL
2	768523	10	FW .343 X .687 X .051/.080H
3	778399	2	FW .781 X 1.375 X .250 ZNY
4	109483	1	LS CHUTE BRACKET
5	109482	1	RS CHUTE BRACKET
6	036244	6	CS .375-16 X 1.00 HX G5
7	767954	12	FW .379 X .813 X .063
8	113340	1	PUSHER
9	015495	2	GREASE FITTING STRAIGHT
10	109487	1	RS CLAMP ANGLE
11	601483	2	RUBBER SIDE FLAP
12	037887	6	CB .312-18 X 1.00 FULL ZN
13	109486	1	LS CLAMP ANGLE
14	016253	4	CB .312-18 X .75 FUL ZN
15	114653	1	DUST SHIELD
16	114522	1	REAR DECK STOP
17	086660	6	NT .375-16 HX G5 ZY NL
18	107712	2	DISCHARGE CHUTE ANGLE
19	600930	2	REAR FLAP
20	101360	2	DECK STIFFENER ANGLE
21	710194	6	CB .375-16 X 1.50 STD G5

NOTES:

72" Rear Discharge Deck

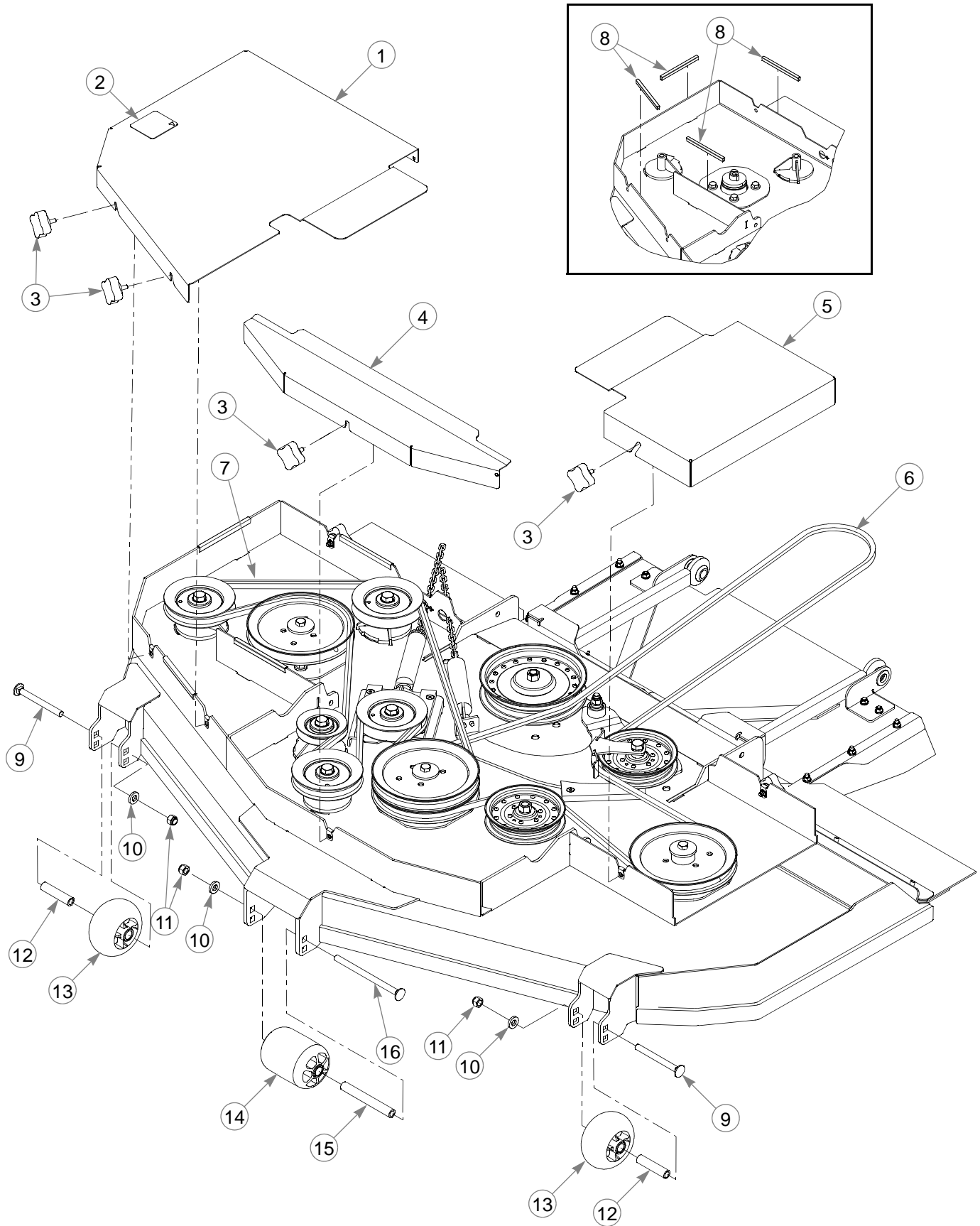

72" Rear Discharge Deck

INDEX NO.	PART NO.	QTY.	DESCRIPTION
1	551050	1	RS PULLEY COVER (WITH DECAL)
2	601837	1	DECK DANGERS DECAL
3	792002	6	KNOB 5/16-18 X 3/4"
4	114209	1	CENTER PULLEY COVER
5	114490	1	LS PULLEY COVER
6	797928	1	BELT, B 160.2" EL
7	603422	1	BELT, HBB SECTION 140.3
8	111339	4	FLEX TRIM
9	603049	2	CB .500-13 X 5.00 ZNYC
10	767962	3	FW .531 X 1.063 X .175
11	781567	3	NT .500-13 HX G8 NL
12	602345	2	SPACER 3.22
13	602263	2	PLASTIC WHEEL
14	602341	1	PLASTIC WHEEL
15	602344	1	SPACER 5.73
16	602338	1	CB .500-13 X 7.50 STD ZN

NOTES:

72" Rear Discharge Deck

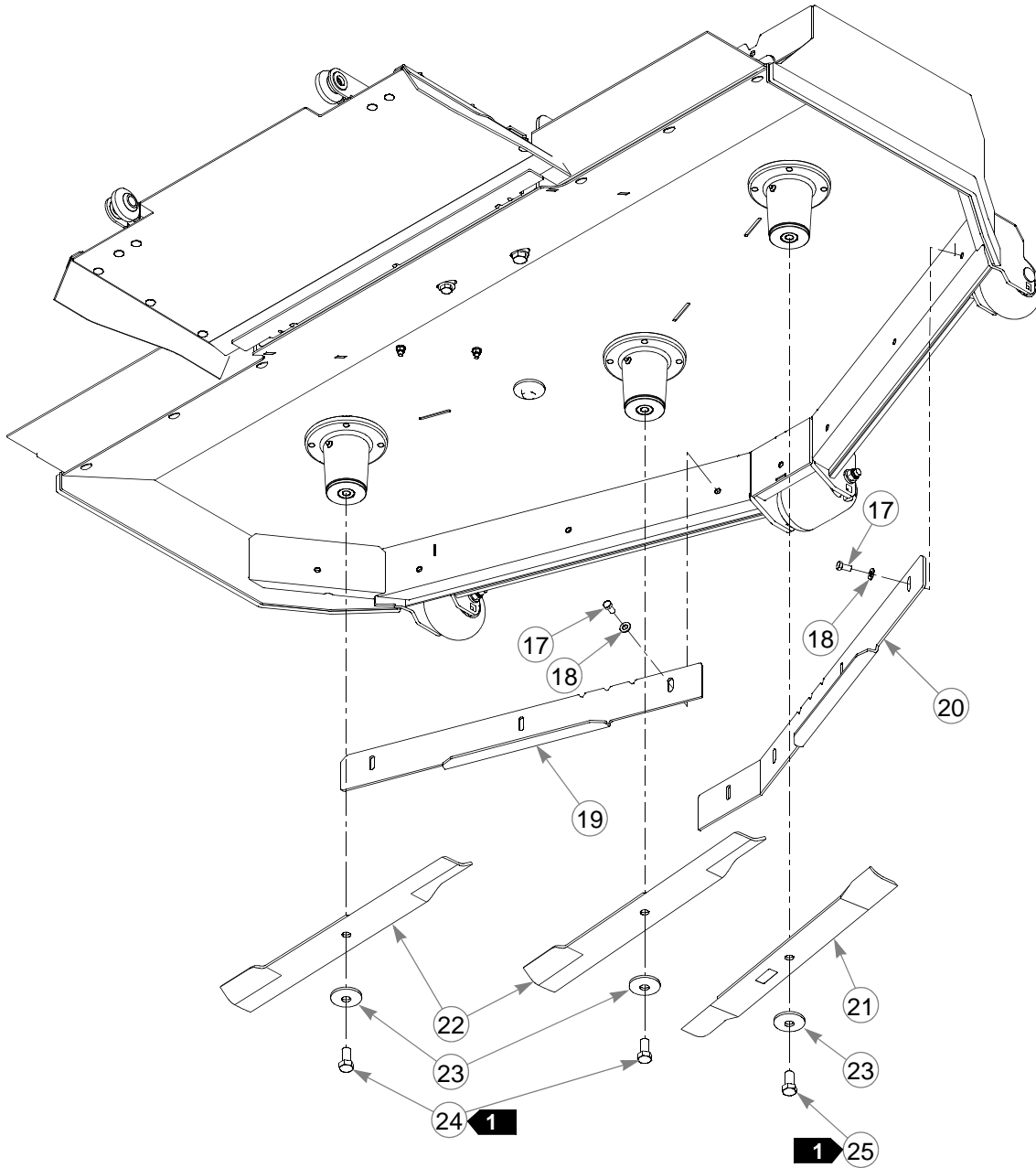

72" Rear Discharge Deck

INDEX NO.	PART NO.	QTY.	DESCRIPTION
17	055822	7	CS .375-16 X .75 HX G5
18	767954	7	FW .379 X .813 X .063
19	114492	1	LS ADJUSTABLE BAFFLE
20	114491	1	RS ADJUSTABLE BAFFLE
21	796508	1	BLADE, F23.86" -L-F-CCW
	601929	1	BLADE, 23.86" GAT-F-CCW
22	796839	2	BLADE, F23.86" -L-F-CW
	794867	2	BLADE, 23.86" -GAT-F-CW
23	782474	3	CW .631 X 2.25 X .187 PNT
24	781872	2	CS .625-11 X 1.25 HX G5 Z
25	604383	1	CS .625-11 X 1.25 HX G5 LH THREAD

NOTES:

1. Torque to 118 ft-lbs.

Deck Lift

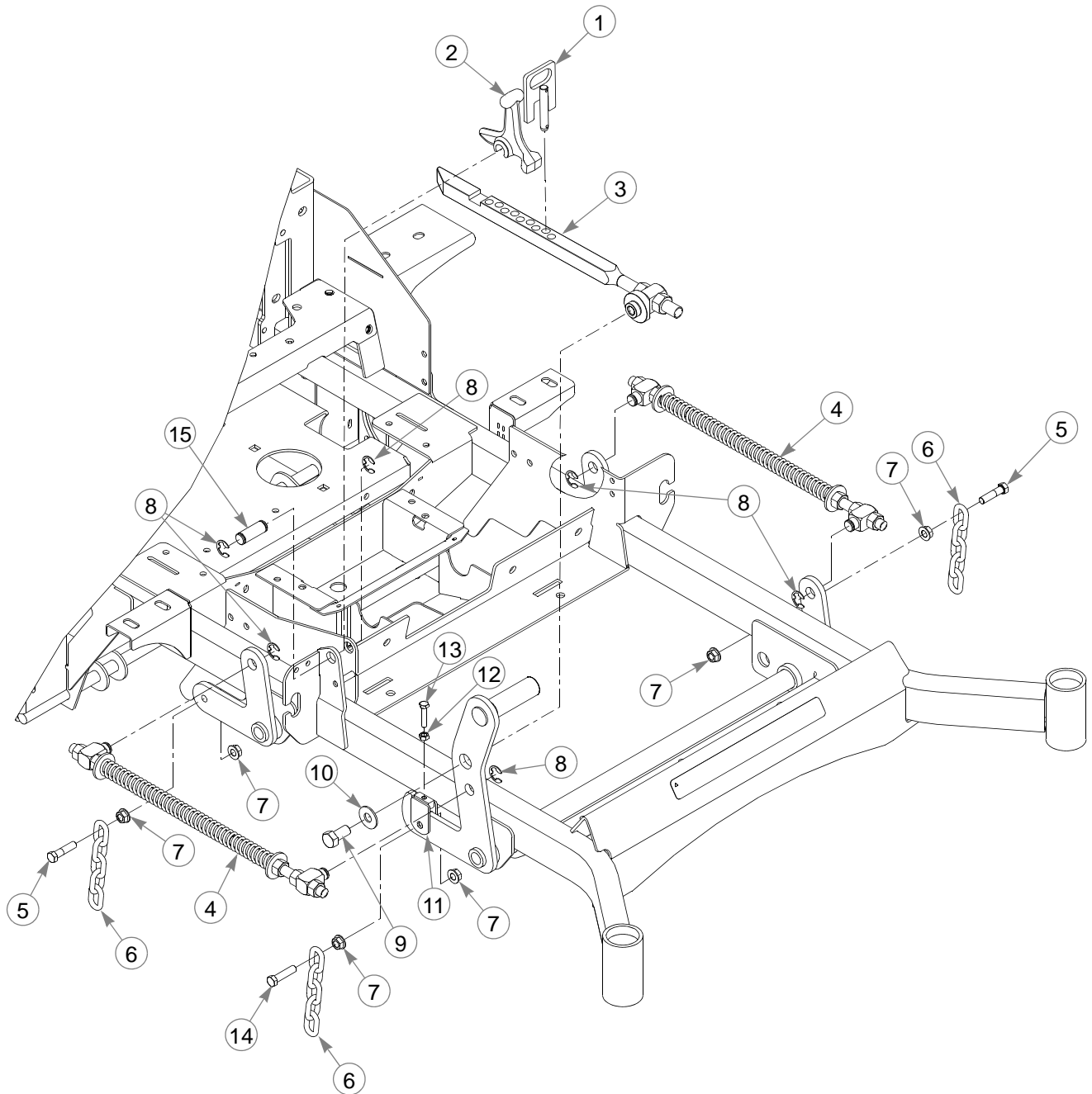

Deck Lift

INDEX NO.	PART NO.	QTY.	DESCRIPTION
1	600437	1	DECK HEIGHT PIN
2	348318	1	STOP HANDLE
3	602898	1	DECK LIFT INDICATOR
4	603184	2	DECK LIFT SPRING
5	055749	7	CS .437-14 X 1.75 HX G5
6	348391	4	DECK LIFT CHAIN
7	704643	16	NT .437-14 HX FLG ZN
8	781294	6	E CLIP 1.00 X .625 X .05
9	781872	1	CS .625-11 X 1.25 HX G5 Z
10	704783	1	FW .625 X 1.50 X .105 ZN
11	348458	1	DECK LEVELER YOKE
12	034272	1	NT .312-18 HX G5
13	756270	1	CS .312-18 X 1.50 HX G5
14	781831	1	CS .437-14 X 1.75 HX G5
15	781229	1	CE .750 X 2.25 X 1.75 HEAD

NOTES:

Deck Mounting Hardware

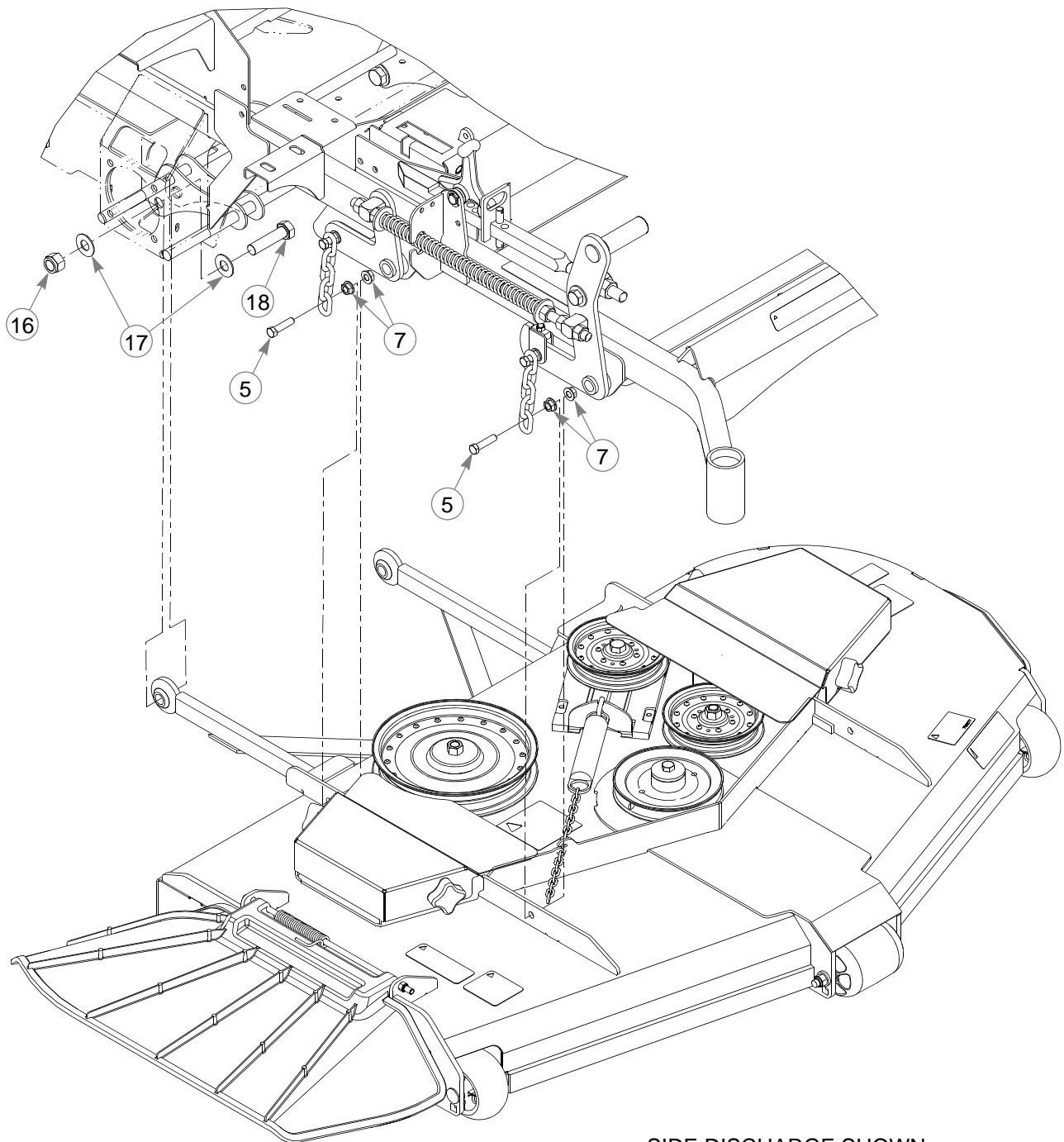

SIDE DISCHARGE SHOWN
REAR DISCHARGE SIMILAR

Deck Mounting Hardware

INDEX NO.	PART NO.	QTY.	DESCRIPTION
16	061101	2	NT .750-10 HX ZY NL
17	025296	4	FW .760 X 1.625 X .08 ZNYC
18	051169	2	CS .750-10 X 3.00 HX G5 (SIDE DISCHARGE MOWER)
	789115	2	CS .750-10 X 3.50 HX G5 (REAR DISCHARGE MOWER)
19	015495	4	GREASE FITTING, STRAIGHT (NOT SHOWN, REAR DISCHARGE MOWER)

NOTES:

Section 8

Seat, Super Deluxe	8-2
Seat Service Parts, Super Deluxe	8-4
Seat, Suspension—S/N 15010001 & Higher	8-6
Seat, Suspension—S/N Prior to 15010001	8-8
Seat Service Parts, Suspension—S/N 150100001 & Higher	8-10
Seat Service Parts, Suspension—S/N Prior to 150100001	8-11
ROPS—S/N 15010001 & Higher	8-12
ROPS—S/N Prior to 15010001	8-14

Seat, Super Deluxe

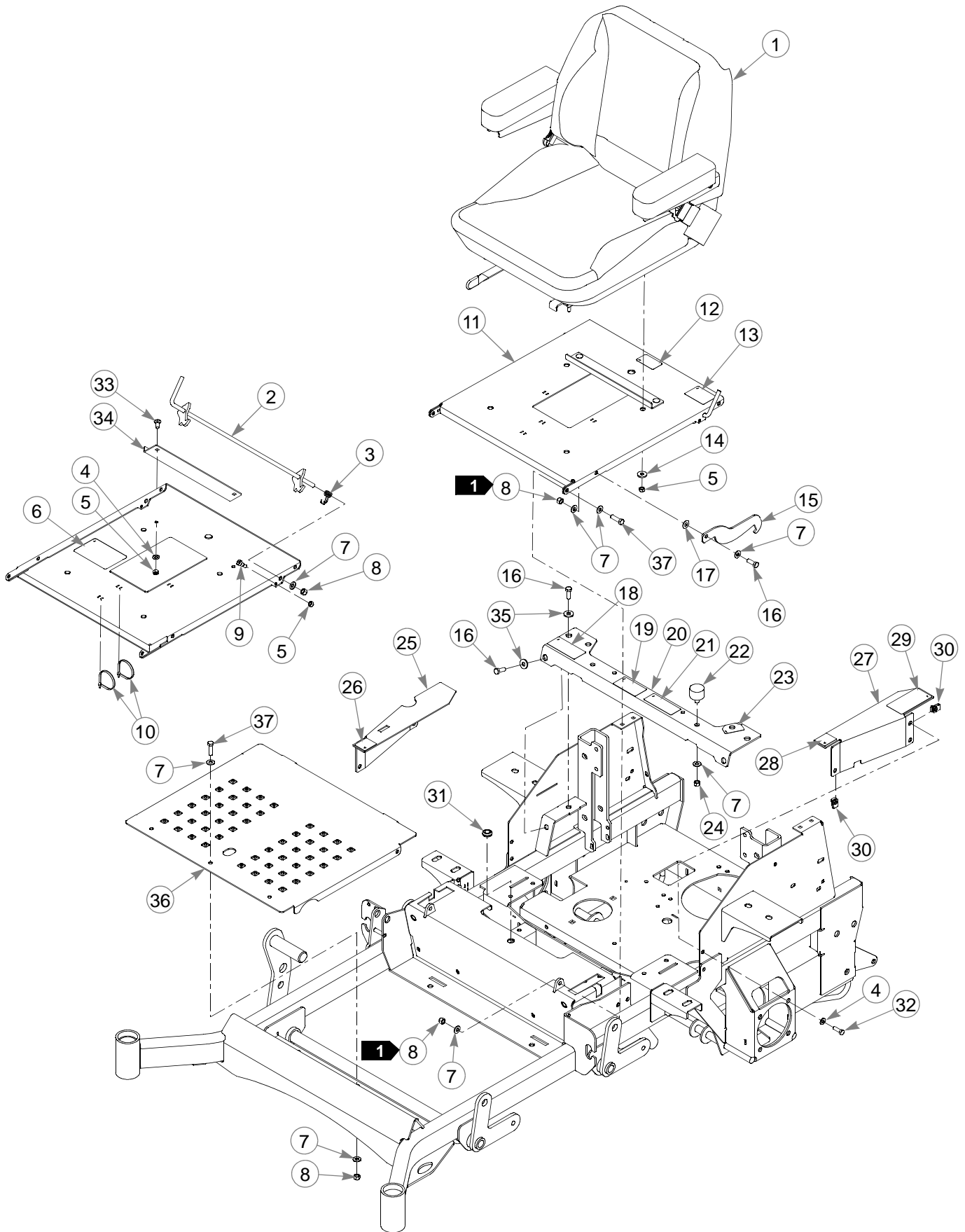

Seat, Super Deluxe

INDEX NO.	PART NO.	QTY.	DESCRIPTION
1	602966	1	SUPER DELUXE SEAT
2	113157	1	SEAT LATCH
3	783910	1	TORSION SPRING
4	768523	7	FW .343 X .687 X .051/.080H
5	058776	7	NT .312-18 HX ZY NL
6	601815	1	BATTERY WARNINGS DECAL
7	767954	13	FW .379 X .813 X .063
8	086660	6	NT .375-16 HX G5 ZY NL
9	754358	1	SB .375 X .375 SH .312-18
10	000331	2	WIRE TIE
11	550815	1	SEAT PAN (WITH DECALS & INSTALLATION KIT)
12	605688	1	LEVEL FUEL FILL DECAL
13	785188	1	ARMREST WARNING DECAL
14	712927	4	FW .344 X 1.00 X .12 HRD Z
15	350421	2	SEAT PAN STOP
16	036244	6	CS .375-16 X 1.00 HX G5
17	724716	2	FIBER WASHER
18	601967	1	ENGINE COMPARTMENT DECAL
19	601968	1	HYDRAULIC PRESSURE DECAL
20	550816	1	SEAT SUPPORT (WITH DECALS)
21	779280	1	HOT & HYD OIL DECAL
22	601650	2	VIBRATION MOUNT
23	791848	1	FUEL INDICATOR DECAL
24	054502	2	NT .375-16 HX G5 ZNY
25	550824	1	RS FRAME COVER (WITH DECALS)
26	785220	1	RS STEERING DECAL
27	550823	1	LS FRAME COVER (WITH DECALS)
28	785139	1	LS STEERING DECAL
29	600899	1	PUMP BELT WARNING DECAL
30	601069	5	CN .312-18 X .20 MAX THK
31	080358	1	GM .50 X 1.00 X .75 X .12
32	036236	5	CS .312-18 X 1.00 HX G5
33	016253	2	CB .312-18 X .75 FUL ZN
34	113713	1	SEAT STOP
35	712919	4	FW .406 X 1.00 X .12 HRD Z
36	117323	1	FLOOR PAN
37	052860	3	CS .375-16 X 1.25 HX G5 ZN

NOTES:

1. Do not torque; the seat pan & seat pan stop must pivot freely.

Seat Service Parts, Super Deluxe

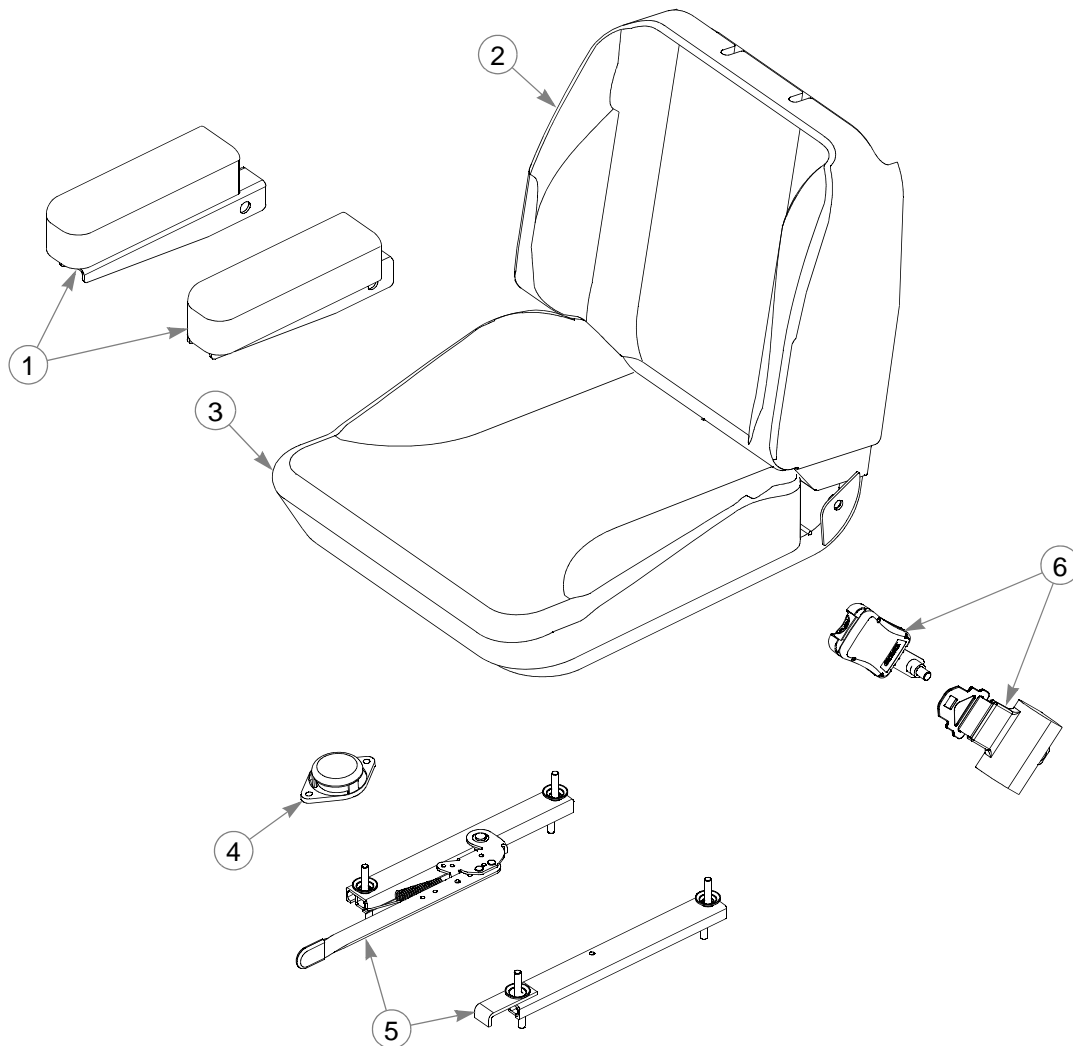

INDEX NO.	PART NO.	QTY.	DESCRIPTION
1	603260	1	ARMREST KIT
2	603694	1	BACK SEAT COVER
3	603693	1	BOTTOM SEAT COVER
4	603148	1	SEAT SWITCH
5	603146	1	STANDARD SEAT TRACK SET
6	603133	1	SEAT BELT KIT

NOTES:

This page intentionally left blank.

Seat, Suspension—S/N 15010001 & Higher

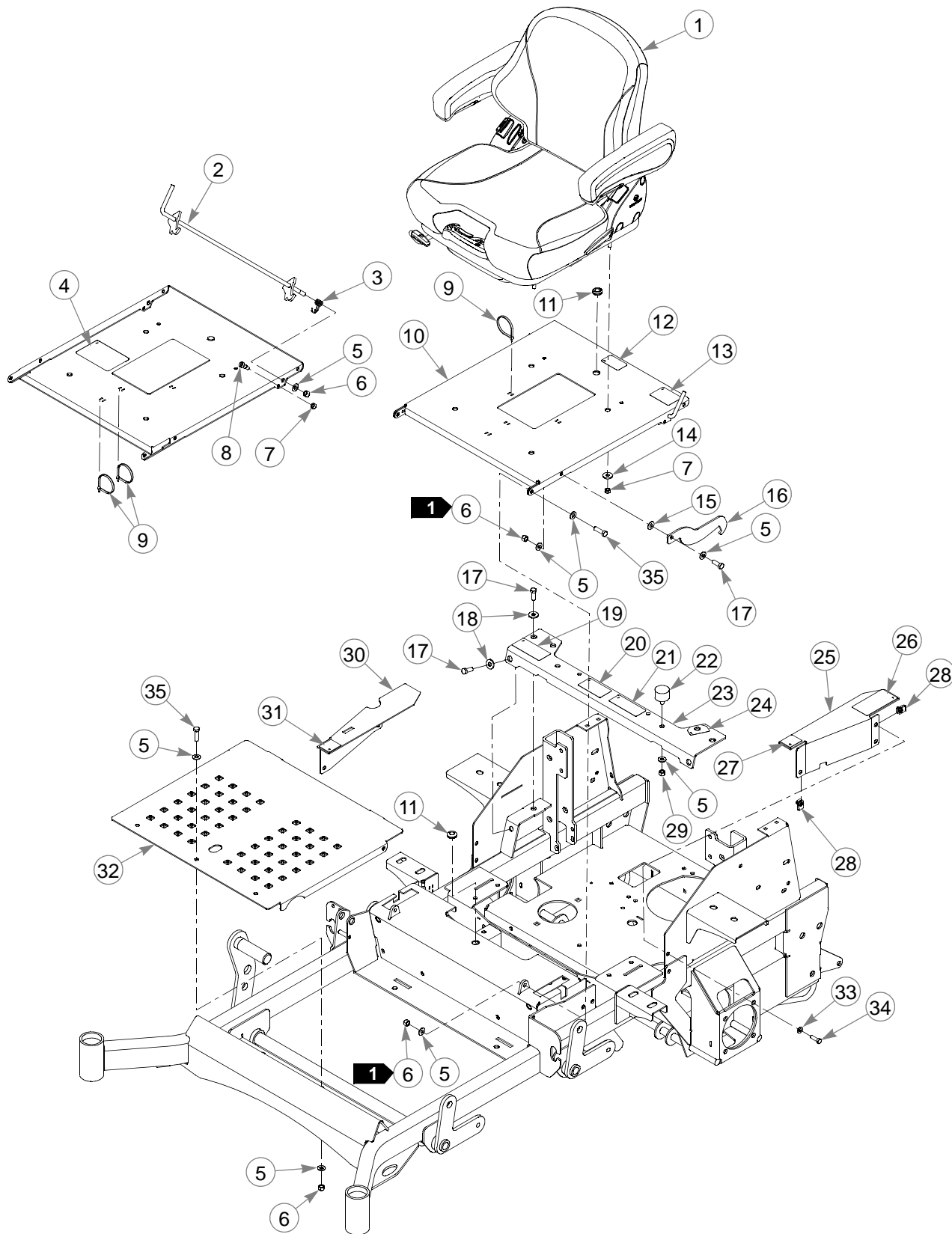

Seat, Suspension—S/N 15010001 & Higher

INDEX NO.	PART NO.	QTY.	DESCRIPTION
1	605698	1	SEAT
2	113157	1	SEAT LATCH
3	783910	1	TORSION SPRING
4	601815	1	BATTERY WARNINGS DECAL
5	767954	13	FW .379 X .813 X .063
6	086660	6	NT .375-16 HX G5 ZY
7	058776	5	NT .312-18 HX G5 ZY
8	754358	1	SB .375 X .375 SH .312-18
9	000331	3	WIRE TIE
10	550815	1	SEAT PAN (WITH DECALS & INSTALLATION KIT)
11	080358	1	GM .50 X 1.00 X .75 X .12
12	605688	1	LEVEL FUEL FILL DECAL
13	785188	1	ARMREST WARNING DECAL
14	712927	4	FW .344 X 1.00 X .12 HRD Z
15	724716	2	FIBER WASHER
16	350421	2	SEAT PAN STOP
17	036244	6	CS .375-16 X 1.00 HX G5
18	712919	4	FW .406 X 1.00 X .12 HRD Z
19	601967	1	ENGINE COMPARTMENT DECAL
20	601968	1	HYDRAULIC PRESSURE DECAL
21	779280	1	HOT & HYD OIL DECAL
22	601650	2	VIBRATION MOUNT
23	550816	1	SEAT SUPPORT (WITH DECALS)
24	791848	1	FUEL INDICATOR DECAL
25	550823	1	LS FRAME COVER (WITH DECALS)
26	600899	1	PUMP BELT WARNING DECAL
27	785139	1	LS STEERING DECAL
28	601069	5	CN .312-18 X .20 MAX THK
29	054502	2	NT .375-16 HX G5 ZNY
30	550824	1	RS FRAME COVER (WITH DECALS)
31	785220	1	RS STEERING DECAL
32	117323	1	FLOOR PAN
33	768523	5	FW .343 X .687 X .051/.080H
34	036236	5	CS .312-18 X 1.00 HX G5
35	052860	3	CS .375-16 X 1.25 HX G5 ZN
36	604439	1	WIRE HARNESS (NOT SHOWN)

NOTES:

1. Do not torque; the seat pan and seat pan stop must pivot freely.

Seat, Suspension—S/N Prior to 15010001

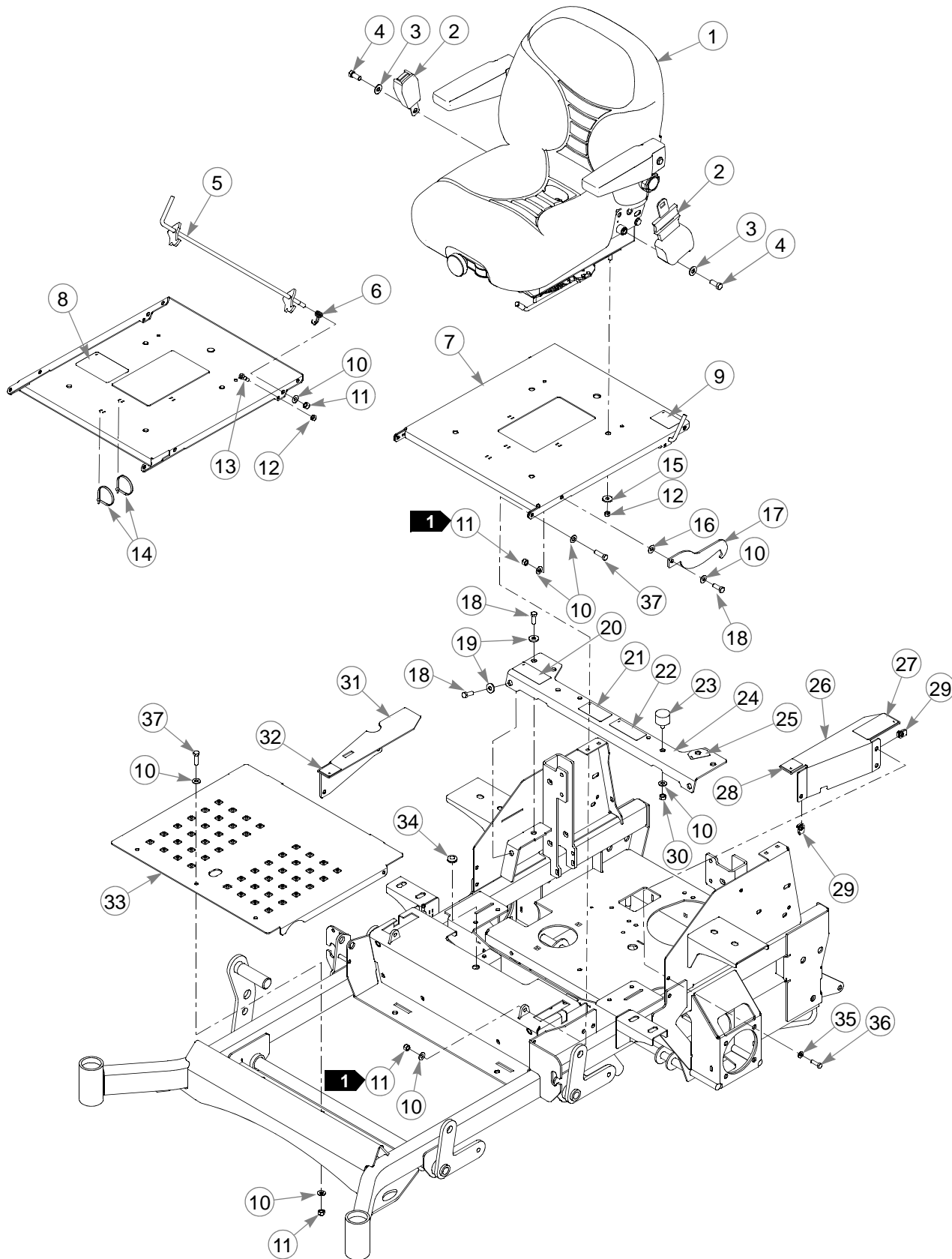

Seat, Suspension—S/N Prior to 15010001

INDEX NO.	PART NO.	QTY.	DESCRIPTION
1	792051	1	SUSPENSION SEAT
2	601444	1	SEAT BELT
3	017129	2	FW .440 X 1.00 X .083 ZNY
4	797076	2	CS .437-20 X 1.00 HX G8 ZNYC
5	113157	1	SEAT LATCH
6	783910	1	TORSION SPRING
7	550815	1	SEAT PAN (WITH DECALS & INSTALLATION KIT)
8	601815	1	BATTERY WARNINGS DECAL
9	785188	1	ARMREST WARNING DECAL
10	767954	13	FW .379 X .813 X .063
11	086660	6	NT .375-16 HX G5 ZY NL
12	058776	5	NT .312-18 HX G5 ZY NL
13	754358	1	SB .375 X .375 SH .312-18
14	000331	2	WIRE TIE
15	712927	4	FW .344 X 1.00 X .12 HRD Z
16	724716	2	FIBER WASHER
17	350421	2	SEAT PAN STOP
18	036244	6	CS .375-16 X 1.00 HX G5
19	712919	4	FW .406 X 1.00 X .12 HRD Z
20	601967	1	ENGINE COMPARTMENT DECAL
21	601968	1	HYDRAULIC PRESSURE DECAL
22	779280	1	HOT & HYD OIL DECAL
23	601650	2	VIBRATION MOUNT
24	550816	1	SEAT SUPPORT (WITH DECALS)
25	791848	1	FUEL INDICATOR DECAL
26	550823	1	LS FRAME COVER (WITH DECALS)
27	600899	1	PUMP BELT WARNING DECAL
28	785139	1	LS STEERING DECAL
29	601069	5	CN .312-18 X .20 MAX THK
30	054502	2	NT .375-16 HX G5 ZNY
31	550824	1	RS FRAME COVER (WITH DECALS)
32	785220	1	RS STEERING DECAL
33	117323	1	FLOOR PAN
34	080358	1	GM .50 X 1.00 X .75 X .12
35	768523	5	FW .343 X .687 X .051/.080H
36	036236	5	CS .312-18 X 1.00 HX G5
37	052860	3	CS .375-16 X 1.25 HX G5 ZN

NOTES:

1. Do not torque; the seat pan and seat pan stop must pivot freely.

Seat Service Parts, Suspension—S/N 150100001 & Higher



INDEX NO.	PART NO.	QTY.	DESCRIPTION
1	605750	1	BACK CUSHION
2	604938	1	RS ARMREST
3	604937	1	LS ARMREST
4	604941	1	SEAT BELT
5	605752	1	SEAT CUSHION
6	119287	1	SLIDE KIT
7	604973	1	SEAT SWITCH (NOT SHOWN)

Seat Service Parts, Suspension—S/N Prior to 150100001

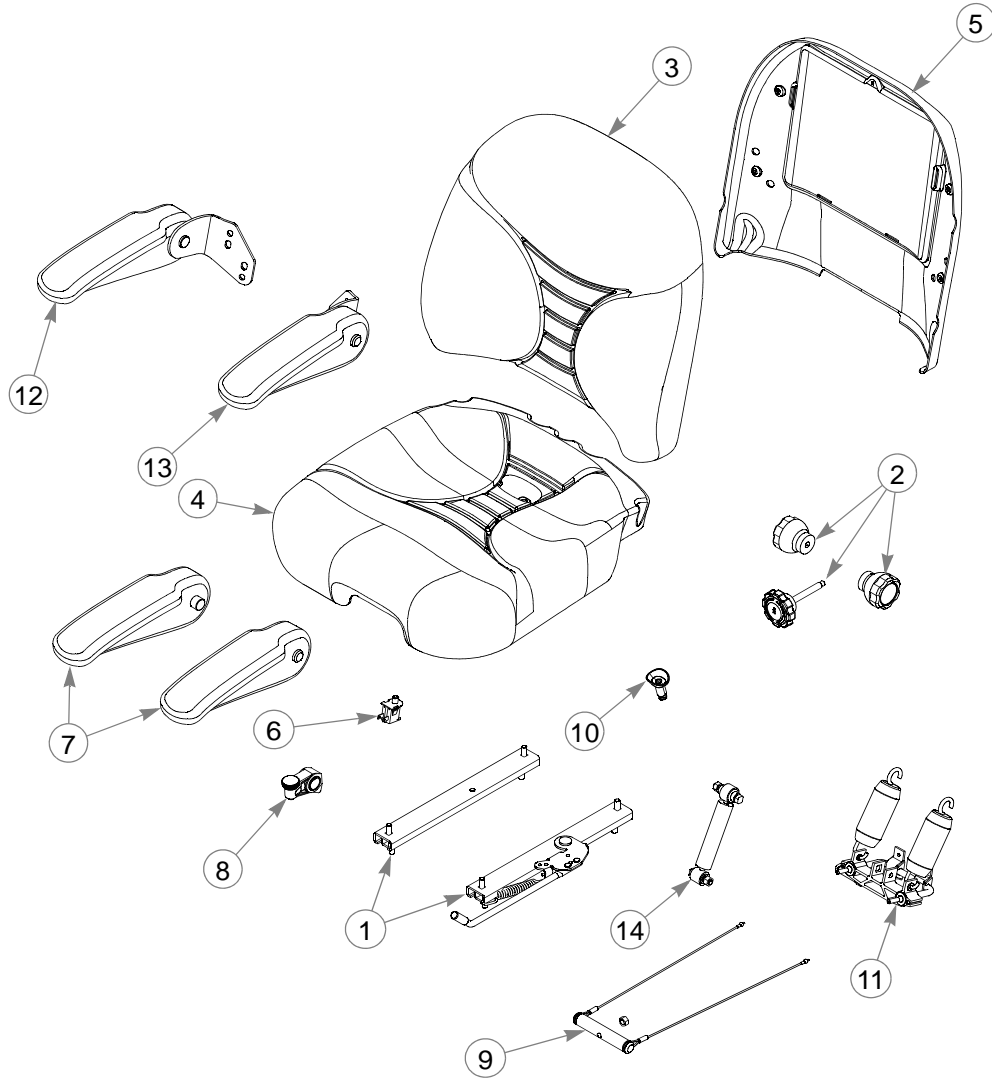

INDEX NO.	PART NO.	QTY.	DESCRIPTION
1	793307	1	SLIDE KIT
2	793323	1	KNOB KIT
3	793281	1	BACK CUSHION KIT
4	793299	1	BOTTOM CUSHION KIT
5	797571	1	SEAT BACK PANEL KIT
6	793315	1	SEAT SWITCH
7	797480	1	MOLDED ROUND ARMREST
8	793273	1	ARMREST STOP ASSEMBLY
9	601458	1	SEAT WEIGHT ADJUSTMENT KIT
10	602076	1	SEAT DRAIN REPLACEMENT
11	603040	1	SPRING SADDLE KIT
12	601533	1	RS ROUND ARMREST ASSEMBLY (WITH BRACKET)
13	601534	1	LS ROUND ARMREST ASSEMBLY (WITH BRACKET)
14	603152	1	SHOCK ABSORBER KIT

ROPS—S/N 15010001 & Higher

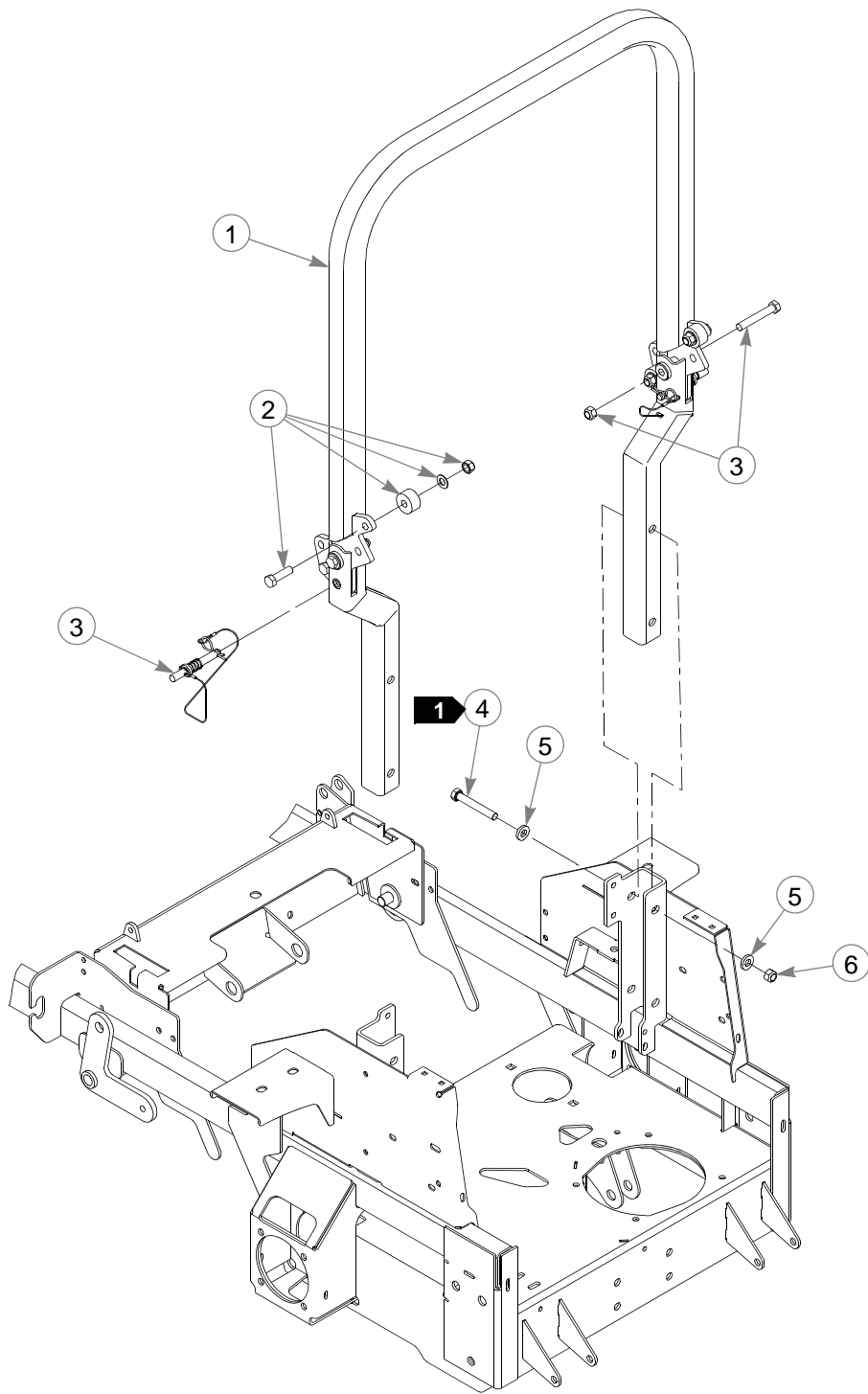

ROPS—S/N 15010001 & Higher

INDEX NO.	PART NO.	QTY.	DESCRIPTION
1	605639	1	ROPS KIT
2	605731	2	POLY STOP KIT
3	605638	1	ROPS HARDWARE KIT
4	061812	4	CS .500-13 X 3.50 HX G5
5	767962	8	FW .531 X 1.063 X .175
6	023317	4	NT .500-13 UNT LK G8 ZN

NOTES:

1. Torque to 73 ft-lbs.

ROPS—S/N Prior to 15010001

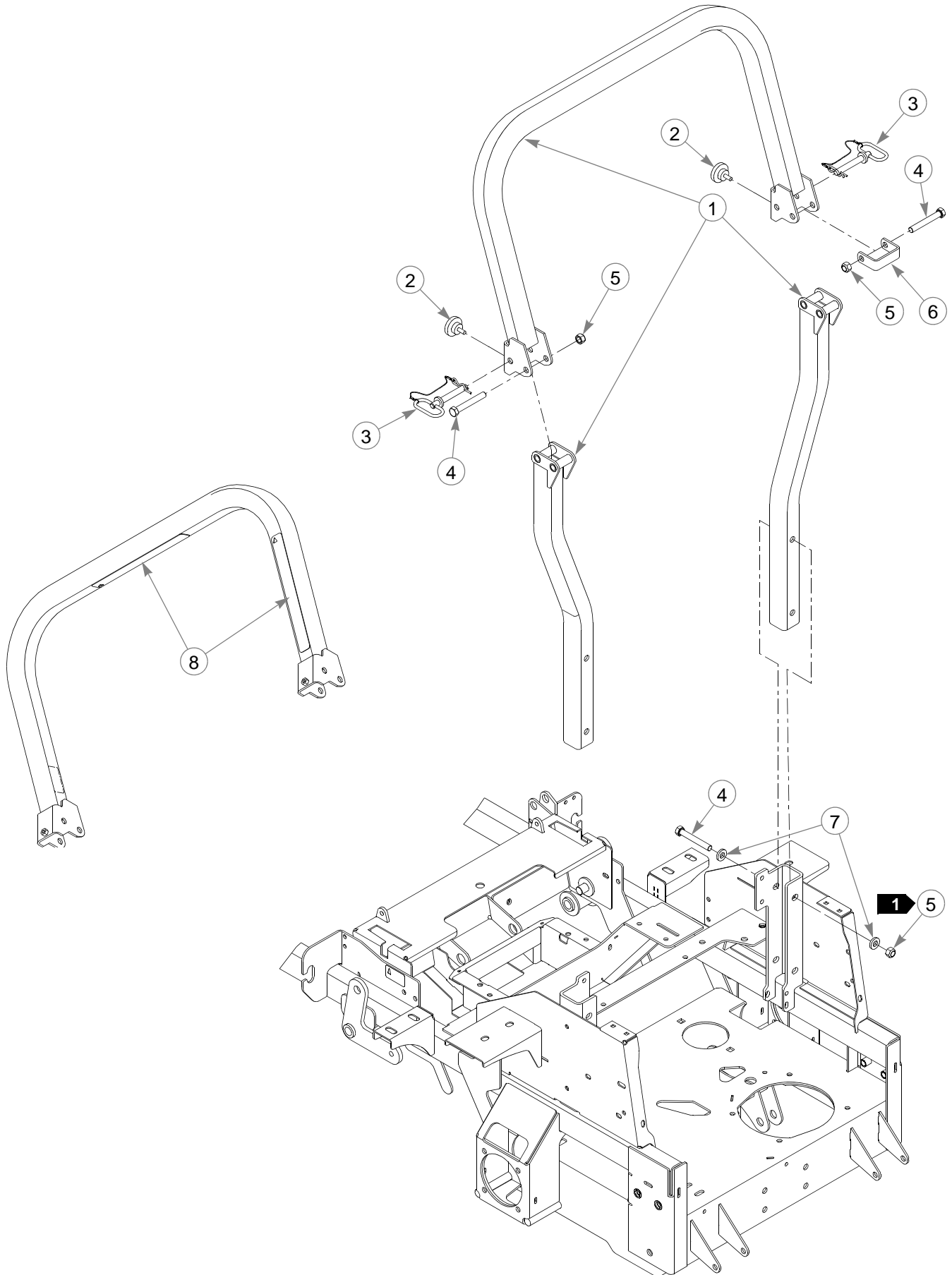

ROPS—S/N Prior to 15010001

INDEX NO.	PART NO.	QTY.	DESCRIPTION
1	603338	1	ROPS KIT (WITH DECALS, SEATBELT & HARDWARE)
2	601470	2	HAND KNOB
3	601471	2	LYNCH PIN W/ LANYARD
4	061812	6	CS .500-13 X 3.50 HX G5
5	023317	6	NT .500-13 UNT G8
6	603099	1	ROPS STOP
7	767962	8	FW .531 X 1.063 X .175
8	601635	2	ROPS DECAL

NOTES:

1. Torque to 73 ft-lbs.
