

*Hustler® Super Z®
Parts Manual*



HUSTLER®

ENGINEERING PERFORMANCE™

200 South Ridge Road
Hesston, Kansas
67062

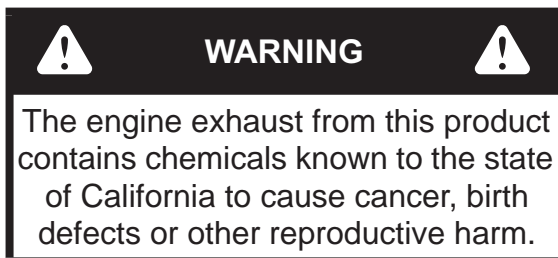

NOTICE OF REQUIREMENT OF SPARK ARRESTER MUFFLER

This equipment may create sparks that can start fires around dry vegetation. California Public Resources Code Section 4442.6 provides that it is unlawful to use or operate an internal combustion engine on any forest-covered, brush-covered, or grass-covered land unless the engine is equipped with a spark arrester maintained in effective working order. A spark arrester is a device constructed of nonflammable materials specifically for the purpose of removing and retaining carbon and other flammable particles over 0.0232 of an inch in size from the exhaust flow of an internal combustion engine that uses hydrocarbon fuels or which is qualified and rated by the United States Forest Service. Other states or federal areas may have similar laws. The Operator Should Contact Local Fire Agencies For Laws or Regulations Relating to Fire Prevention Requirements. **THIS EQUIPMENT DOES NOT HAVE A SPARK ARRESTER AND YOU SHOULD CONTACT YOUR AUTHORIZED DEALER FOR THE PURCHASE OF A SPARK ARRESTER.**

Inspect spark arrester daily; replace every 500 hours or as needed.

The Engine Owner's Manual provides information regarding the U.S. Environmental Protection Agency (EPA) and the California Emission Control Regulation of emission systems, maintenance and warranty.

Keep Engine Owner's Manual with your unit. Should the Engine Owner's Manual become damaged or illegible, replace immediately. Replacements may be ordered per the information found in the Product Information section of the owner's manual.

Federal law and California State law prohibit the following acts or the causing thereof:

1. The removal or rendering inoperative by any person other than for purposes of maintenance, repair, replacement, of any device or element of design incorporated into any equipment for the purposes of emissions control prior to or after its sales or delivery to the ultimate purchaser or while it is in use, or
2. The use of the equipment after such device or element of design has been removed or rendered inoperative by any person.

Table of Contents

General Information

Service Literature	1-1
Options Available From Your Dealer	1-1
Using This Manual	1-1
Hardware Description Codes & Abbreviations	1-2
Standard Torques	1-2

Section 2

Frame	2-2
Decals—Models ending in “US”	2-4
Engine Guard	2-6

Section 3

Hydraulic System	3-2
Hydraulic Reservoir	3-4
Motor Assembly	3-6
Left Pump Assembly	3-8
Right Pump Assembly	3-10
Oil Cooler Mount	3-12
Pump Drive	3-14
Steering	3-16
Steering Assembly	3-18
Steering Cover Assembly	3-20
Left Steering Box Assembly	3-24
Right Steering Box Assembly	3-26
Brake	3-28

Section 4

Wheel & Tire	4-2
Front Wheel Assembly	4-4
Drive Wheel Breakdown	4-6

Section 5

Engine, Kawasaki FX850V	5-2
Engine, Kawasaki FX1000V	5-6
Engine Service Parts, Kawasaki	5-8
Engine, Kohler	5-10
Engine Service Parts, Kohler	5-14
Fuel System, Kawasaki	5-16
Fuel System, Kohler—Without Carbon Canister	5-18
Fuel System, Kohler—With Carbon Canister	5-20
Vapor System, Kohler—With Carbon Canister	5-22
Fuel Tank Service Parts	5-24

Section 6

Battery	6-2
Instrument Panel, Kawasaki	6-4
Instrument Panel, Kohler	6-6

Section 7

54" Service Deck	7-2
54" Deck Pulleys & Spindles	7-4
54" Deck	7-6
60" Side Discharge Service Deck	7-8
60" Side Discharge Deck Pulleys & Spindles	7-10
60" Side Discharge Deck	7-12
66" Service Deck	7-14
66" Deck Pulleys & Spindles	7-16
66" Deck	7-18
72" Side Discharge Service Deck	7-20
72" Side Discharge Deck Pulleys & Spindles	7-22
72" Side Discharge Deck	7-24
60" Rear Discharge Service Deck	7-26
60" Rear Discharge Deck Pulleys & Spindles	7-28
60" Rear Discharge Dust Shield	7-32
60" Rear Discharge Deck	7-34
72" Rear Discharge Service Deck	7-38
72" Rear Discharge Deck Pulleys & Spindles	7-40
72" Rear Discharge Dust Shield	7-44
72" Rear Discharge Deck	7-46
Deck Lift	7-50
Deck Mounting Hardware	7-52

Section 8

Seat, Suspension	8-2
Seat Service Parts, Suspension	8-4
ROPS	8-6

General Information

This manual covers Hustler® Super Z® models **934984US, 934992, 935007, 935015US, 935023, 935031, 935049, 935056US, 935064, 937714 & 937722.**

Service Literature

PART NO.	DESCRIPTION
606230	OPERATOR'S MANUAL
117586	WARRANTY STATEMENT
117588	GENERAL SERVICE MANUAL
113855	CALIFORNIA EMISSIONS WARRANTY STATEMENT (KAWASAKI FX850V/1000V)
122776	CALIFORNIA EMISSIONS WARRANTY STATEMENT (KOHLER ECV860/880)

Options Available From Your Dealer

PART NO.	DESCRIPTION	PART NO.	DESCRIPTION
935460	BAC-VAC CATCHER	113907	54" SAND KIT
935478	3-BAG CATCHER	113679	60" SAND KIT
121923	54" CATCHER ADAPTER KIT	113908	66" SAND KIT
113903	60" CATCHER ADAPTER KIT	113909	72" SAND KIT
113904	66" CATCHER ADAPTER KIT	353961	STEERING LEVER EXTENSION KIT
113905	72" CATCHER ADAPTER KIT	116840	60" STRIPE KIT
113721	54" MULCH KIT (SD DECKS ONLY)	116842	66"/72" STRIPE KIT
113722	60" MULCH KIT (SD DECKS ONLY)	116304	54" VX4 HIGH VACUUM KIT
113723	66" MULCH KIT (SD DECKS ONLY)	116305	60" VX4 HIGH VACUUM KIT
113724	72" MULCH KIT (SD DECKS ONLY)	116306	66" VX4 HIGH VACUUM KIT
603167	FLEX FORK KIT	116307	72" VX4 HIGH VACUUM KIT
113932	HYDRAULIC DECK LIFT KIT	113911	DUAL REAR ANTI-SCALP KIT (60"/66" DECKS)
117147	LIGHT KIT	113910	SINGLE REAR ANTI-SCALP KIT (54"/60"/66"/72" DECKS)
110467	BEACON KIT	113937	DUAL REAR ANTI-SCALP KIT (72" DECKS)
110469	FLASHER KIT	789537	SEMI-PNEUMATIC TIRE/WHEEL
119288	ISOLATOR KIT (GRAMMER SEAT)		

Note: When ordering parts, you must use the part number as shown for each part, not the index number. Always give the model and serial number to your parts and service representative.

Note: Items sold in bulk such as seals and hoses are sold by the foot.

Using This Manual

This manual is part of a service package for the Hustler® mowers. Use of this manual in conjunction with other Hustler® mower and component manuals will provide the information necessary to service and maintain Hustler® mowers.

This Parts Manual provides a complete parts listing for the unit. Use this manual when ordering parts. Illustrations used were current at the time of printing, but subsequent production changes may cause your machine to vary slightly in detail. Excel Industries, Inc. reserves the right to redesign and change the machine as deemed necessary, without notification. If a change has been made to your machine which is not reflected in this parts manual, see your authorized dealer for current information and parts.

The Service Manual is a service guide for use by Service Technicians. It provides the necessary information needed to perform normal maintenance requirements on these units.

The Operator's Manual provides fundamental operational information and operational safety that is needed when operating the mower.

The component manuals are furnished by the various manufacturers to be used for the troubleshooting and servicing of their products.

Hardware Description Codes & Abbreviations

The following codes are used throughout this parts manual. Refer to this list when ordering parts.

ABBREVIATION	DESCRIPTION	ABBREVIATION	DESCRIPTION
CB	CARRIAGE BOLT	MB	MACHINE BUSHING
CE	CLEVIS PIN	MS	MACHINE SCREW
CN	CLIP NUT	NT	NUT
CP	COTTER PIN	SC	SELF TAPPING CAP SCREW
CS	CAP SCREW	SH	SOCKET HEAD
CW	CUP WASHER	SB	SHOULDER BOLT
FDRW	FENDER WASHER	SS	SET SCREW
FW	FLAT WASHER	OD	OUTSIDE DIAMETER
HX	HEX HEAD	ID	INSIDE DIAMETER
LW	LOCK WASHER	WN	WELD NUT

Standard Torques

The following chart lists the standard torque values for the threaded fasteners found in this manual. Torque all cap screws, nuts and set screws to these values unless a different torque is shown in the Notes section next to the fastener.

SIZE	FT-LBS	N•M	SIZE	FT-LBS	N•M
.250	8.2	11.1	M3	1	1.3
.312	17	23	M4	2.2	3
.375	30	40	M5	4.5	6.1
.438	48	65	M6	7.7	10.4
.500	73	99	M8	18.5	25
.562	105	143	M10	37	50
.625	145	200	M12	64	87
.750	260	350	M14	80	108.5
.875	420	565	M16	160	215
1.00	625	850	M20	320	435
			M24	555	750

Section 2

Frame	2-2
Decals—Models ending in “US”	2-4
Engine Guard	2-6

Frame

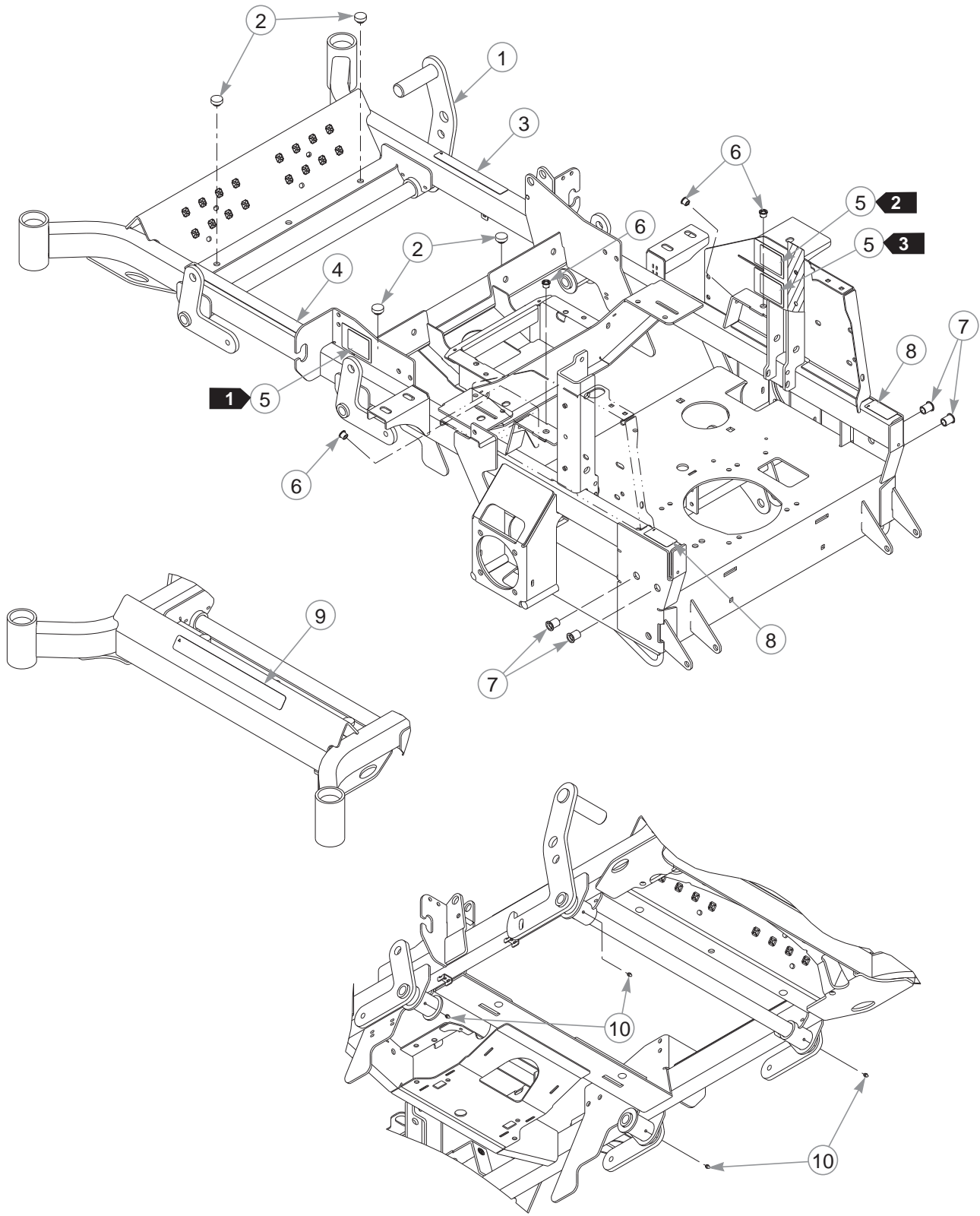

Frame

INDEX NO.	PART NO.	QTY.	DESCRIPTION
1	553269	1	54" SD FRAME (WITH DECALS, RIVET NUTS, BUMPERS & GREASE FITTINGS)
	553159	1	60" SD FRAME (WITH DECALS, RIVET NUTS, BUMPERS & GREASE FITTINGS)
	553158	1	60" RD & 66" SD FRAME (WITH DECALS, RIVET NUTS, BUMPERS & GREASE FITTINGS)
	553160	1	72" SD FRAME (WITH DECALS, RIVET NUTS, BUMPERS & GREASE FITTINGS)
2	781880	4	BUMPER
3	781427	1	DECK HEIGHT DECAL
4	601993	1	SAFE OPERATION DECAL
5	N/A	3	SERIAL NUMBER / SPEC DECAL
6	808493	4	3/8-16 THREAD RIVET NUT
7	600961	4	1/2-13 THREAD RIVET NUT
8	602041	2	HOT DECAL
9	602407	1	HUSTLER ID DECAL
10	015495	4	GREASE FITTING STRAIGHT

NOTES:

1. Serial number decal. In the event the serial number decal becomes damaged or illegible, please contact your dealer to order a replacement.
2. EPA compliance plate.
3. Patent numbers plate.

Decals—Models ending in “US”

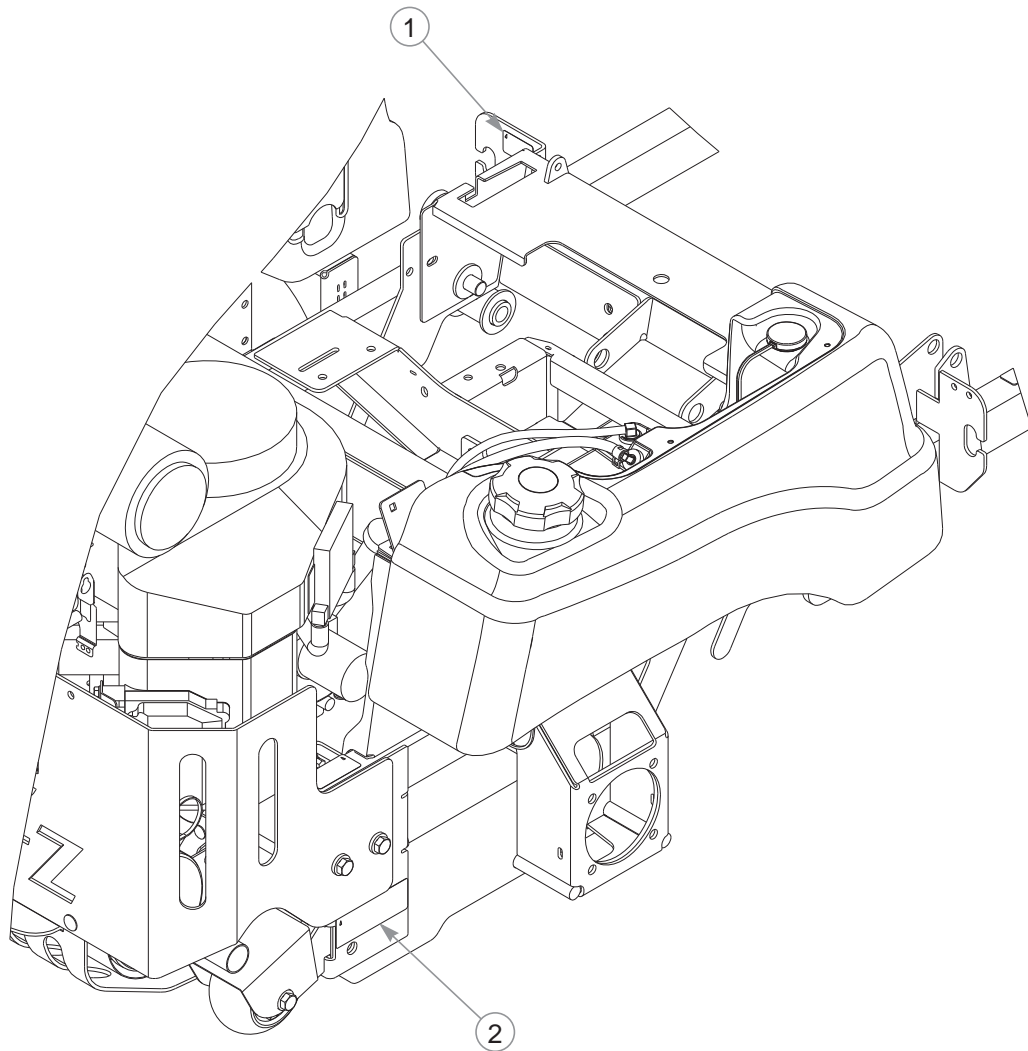

INDEX NO.	PART NO.	QTY.	DESCRIPTION
1	603363	1	ANSI COMPLIANCE DECAL
2	601908	1	SPARK ARRESTER DECAL

NOTES:

This page intentionally left blank.

Engine Guard

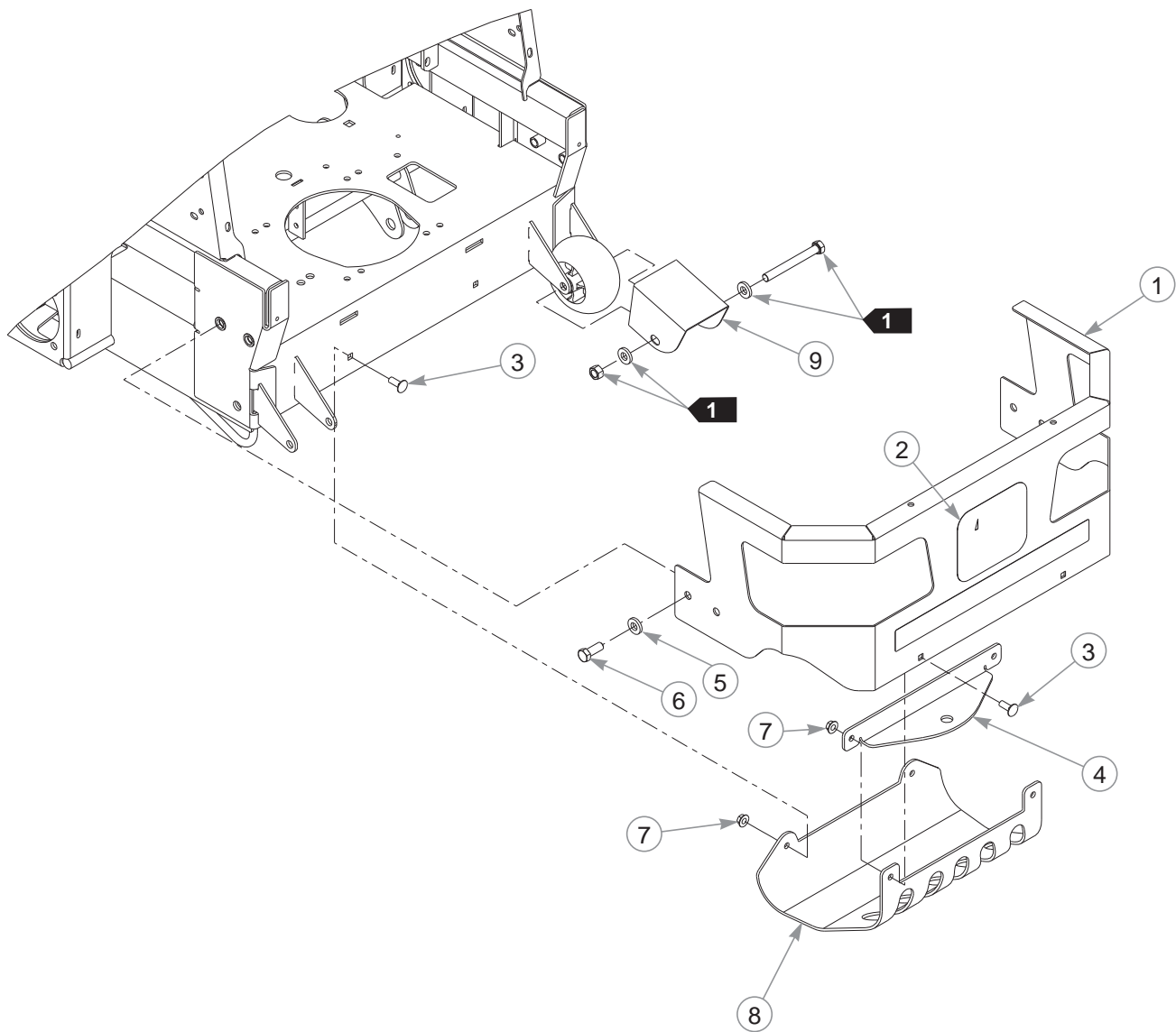

Engine Guard

INDEX NO.	PART NO.	QTY.	DESCRIPTION
1	553457	1	BUMPER (WITH DECAL)
2	604352	1	H LOGO DECAL
3	025395	4	CB .375-16 X 1.00 G5 ZNY
4	121404	1	HITCH
5	767962	4	FW .531 X 1.063 X .175
6	705954	4	CS .500-13 X 1.25 HX G5
7	016899	4	NT .375-16 FLK G5
8	121403	1	MUFFLER GUARD
9	377994	2	SHIELD

NOTES:

1. Part of the Wheel & Tire Assembly.

Section 3

Hydraulic System	3-2
Hydraulic Reservoir	3-4
Motor Assembly	3-6
Left Pump Assembly	3-8
Right Pump Assembly	3-10
Oil Cooler Mount	3-12
Pump Drive	3-14
Steering	3-16
Steering Assembly	3-18
Steering Cover Assembly	3-20
Left Steering Box Assembly	3-24
Right Steering Box Assembly	3-26
Brake	3-28

Hydraulic System

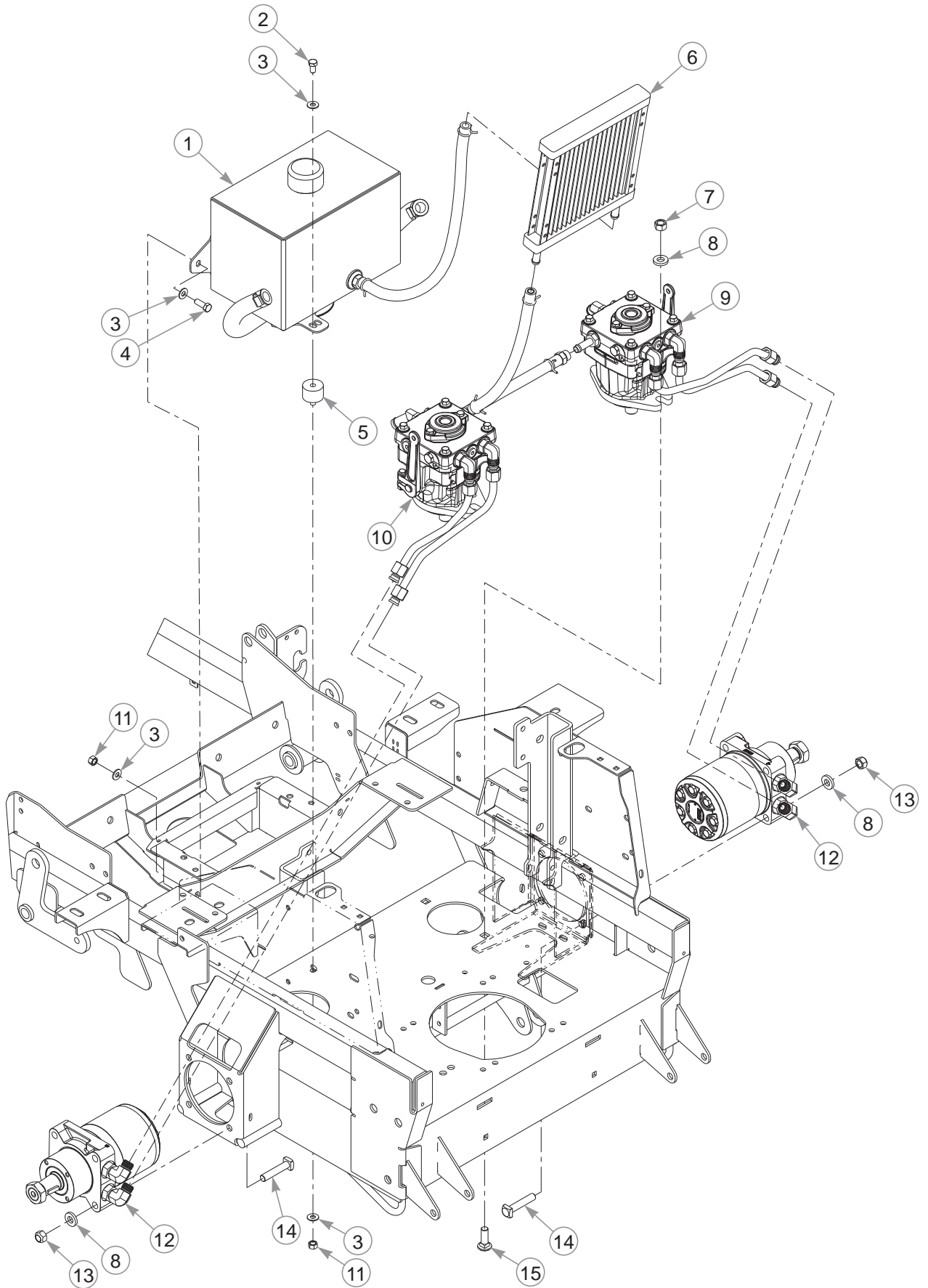

Hydraulic System

INDEX NO.	PART NO.	QTY.	DESCRIPTION
1	N/A	1	RESERVOIR ASSEMBLY
2	056069	1	CS .375-16 X .625 HX G5
3	767954	6	FW .379 X .813 X .063
4	036244	2	CS .375-16 X 1.00 HX G5
5	601571	1	VIBRATION MOUNT
6	601356	1	HYDRAULIC OIL COOLER
7	008193	4	NT .500-13 HX G5 ZNYC
8	767962	12	FW .531 X 1.063 X .175
9	N/A	1	RS PUMP ASSEMBLY
10	N/A	1	LS PUMP ASSEMBLY
11	054502	3	NT .375-16 HX G5 ZNY
12	N/A	2	MOTOR ASSEMBLY
13	023317	8	NT .500-13 UNT LK G8
14	602256	8	CS .500-13 X 2.50 SQ G5
15	028274	4	CB .500-13 X 1.50 FULL

NOTES:

Hydraulic Reservoir

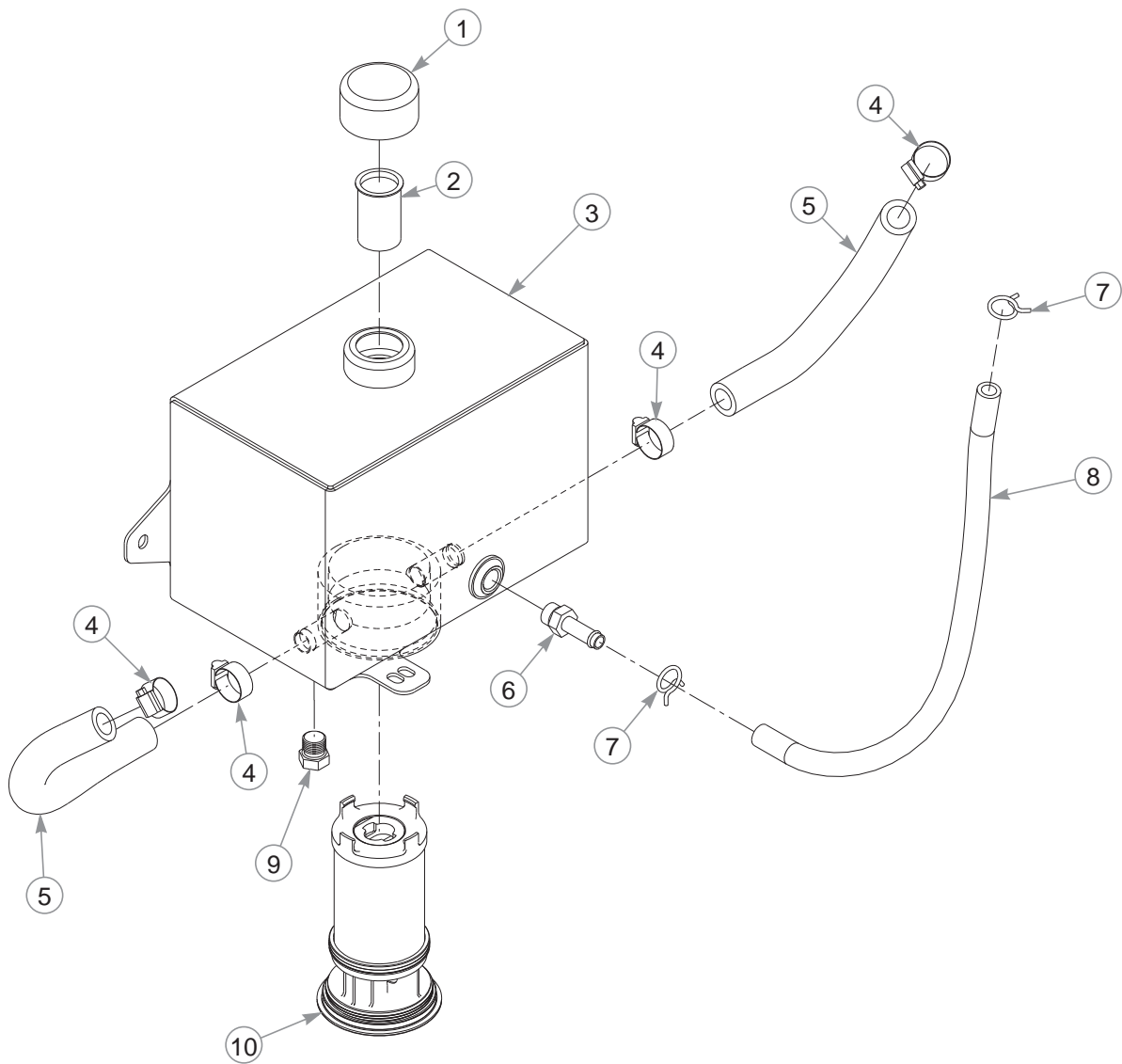

Hydraulic Reservoir

INDEX NO.	PART NO.	QTY.	DESCRIPTION
1	032763	1	BREATHER CAP
2	032771	1	STRAINER
3	606088	1	HYDRAULIC RESERVOIR
4	700484	4	HOSE CLAMP
5	603045	2	PUMP SUCTION HOSE
6	601523	1	FITTING, -8MORB/-8BT STR
7	601001	2	SPRING CLAMP
8	603819	1	COOLER-RES HOSE
9	781658	1	FITTING, -8MORB HEX PLUG
10	602768X	1	HYDRAULIC SUCTION FILTER

NOTES:

Motor Assembly

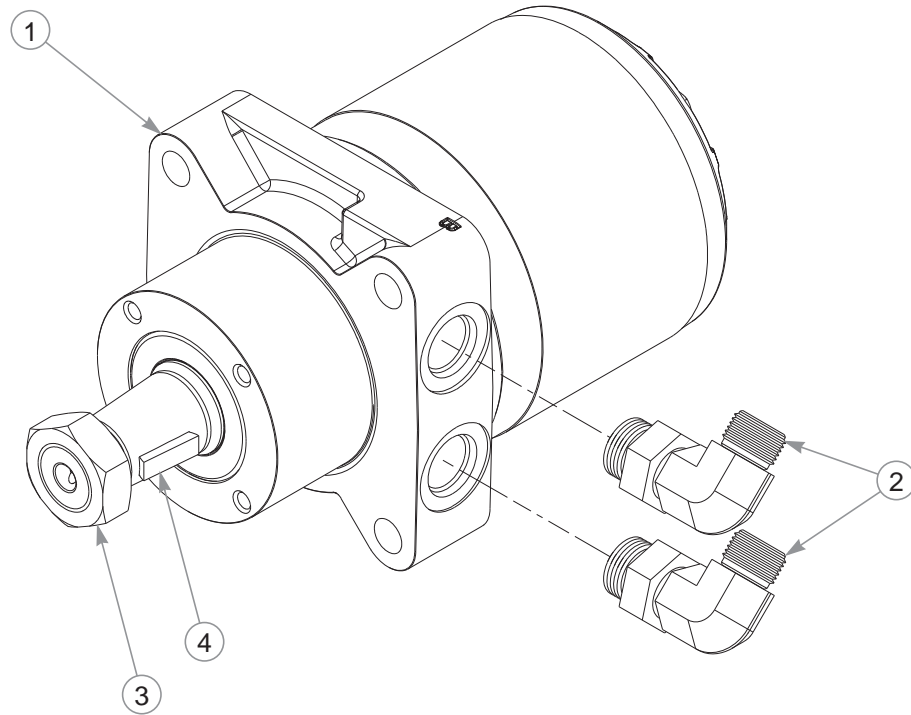

INDEX NO.	PART NO.	QTY.	DESCRIPTION
1	606089	1	MOTOR
2	781526	2	FTG, 90°-10 MORB/-8 MORFS
3	065516	1	CASTLE NUT
4	064337	1	WOODRUFF KEY
5	748806	1	SEAL KIT (NOT SHOWN)

NOTES:

This page intentionally left blank.

Left Pump Assembly

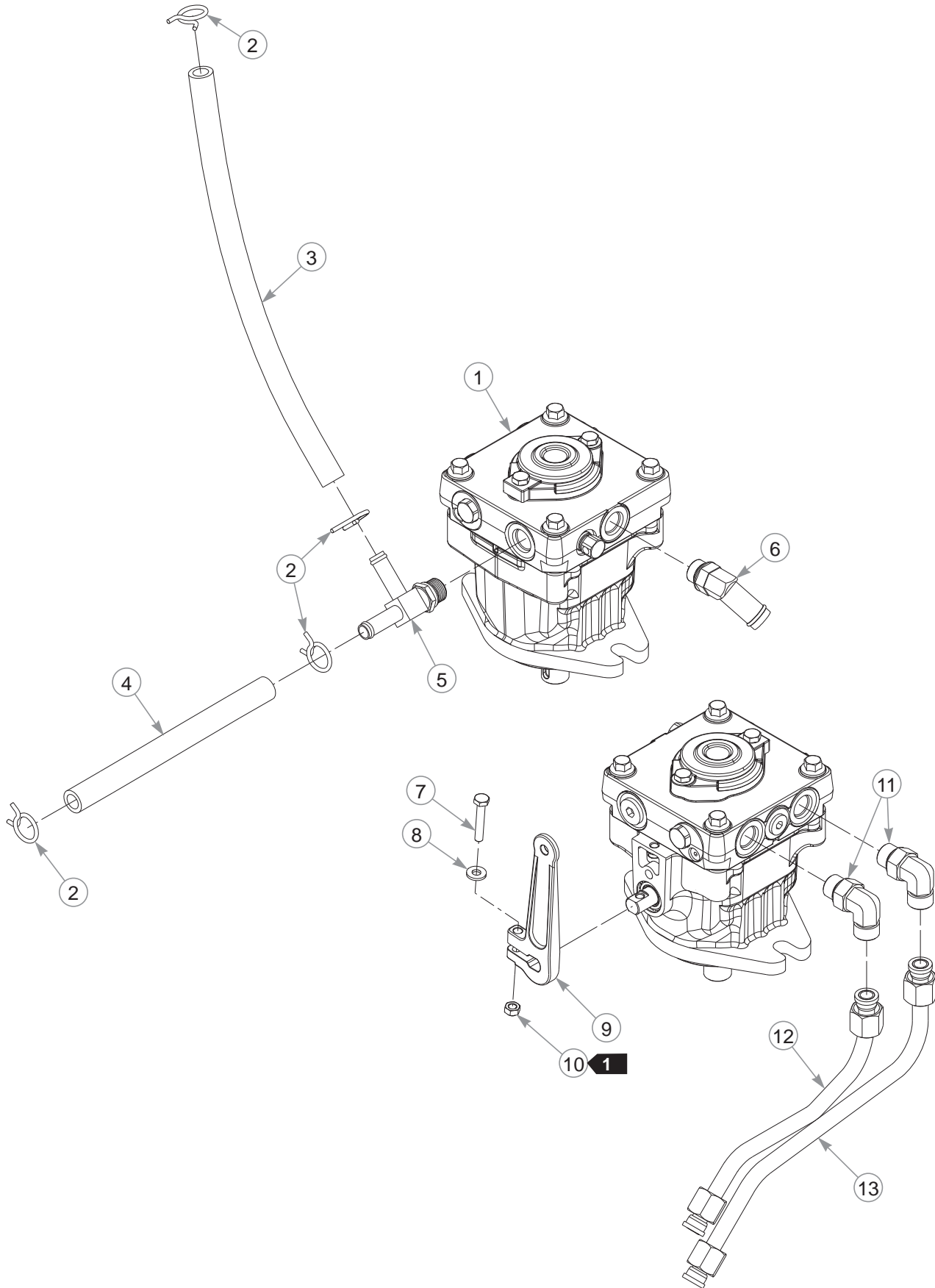

Left Pump Assembly

INDEX NO.	PART NO.	QTY.	DESCRIPTION
1	605759	1	PUMP
2	601001	4	SPRING CLAMP
3	606102	1	PUMP DRAIN HOSE
4	606101	1	PUMP DRAIN HOSE
5	606100	1	FTG, T -8 MORB/BT/BT
6	744854	1	O-RING TUBE ADAPTER 45
7	008581	1	CS .250-20 X 1.50 HX G5
8	768515	1	FW .281 X .625 X .051/.080H
9	604831	1	PUMP ARM
10	068551	1	NT .250-20 HX ZY NL
11	781542	2	FTG, 90°-8MORB/-8MORFS
12	604334	1	TUBE, LP-TM LT LOOP
13	604335	1	TUBE, RP-BM LT LOOP
14	784983	1	SEAL KIT (NOT SHOWN)

NOTES:

1. Torque to 8.2 ft-lbs.

Right Pump Assembly

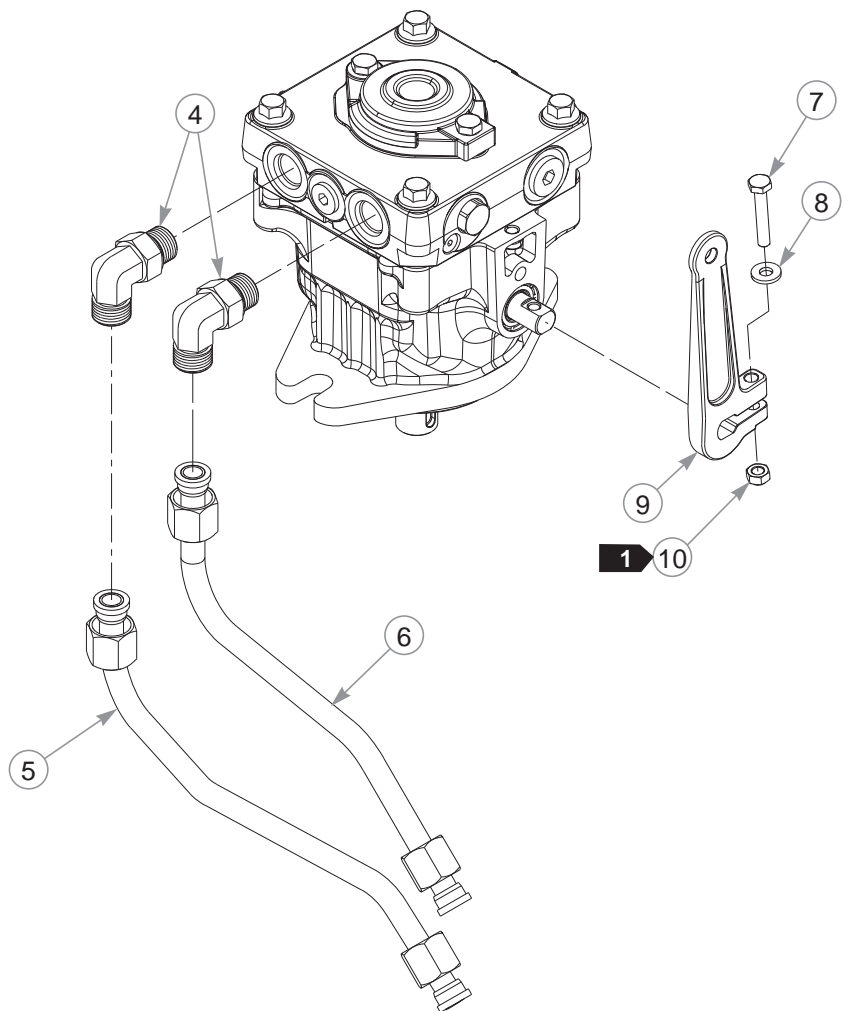
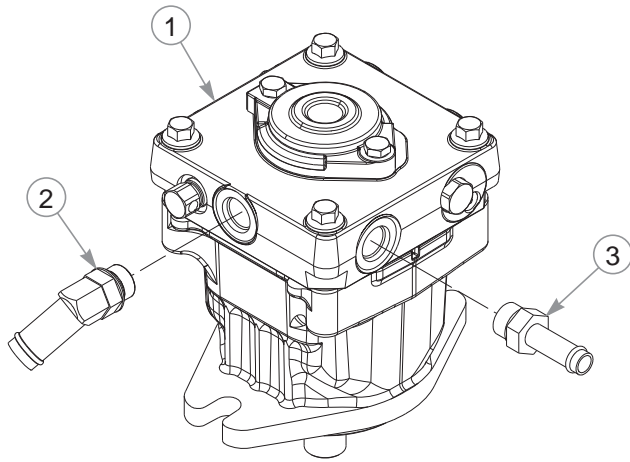

Right Pump Assembly

INDEX NO.	PART NO.	QTY.	DESCRIPTION
1	605760	1	PUMP
2	744854	1	O-RING TUBE ADAPTER 45
3	601523	1	FTG, -8MORB/-8BT STR
4	781542	2	FTG, 90°-8MORB/-8MORFS
5	604333	1	TUBE, LP-TM RT LOOP
6	604332	1	TUBE, RP-BM RT LOOP
7	008581	1	CS .250-20 X 1.50 HX G5
8	768515	1	FW .281 X .625 X .051/.080H
9	604831	1	PUMP ARM
10	068551	1	NT .250-20 HX ZY NL
11	784983	1	SEAL KIT (NOT SHOWN)

NOTES:

1. Torque to 8.2 ft-lbs.

Oil Cooler Mount

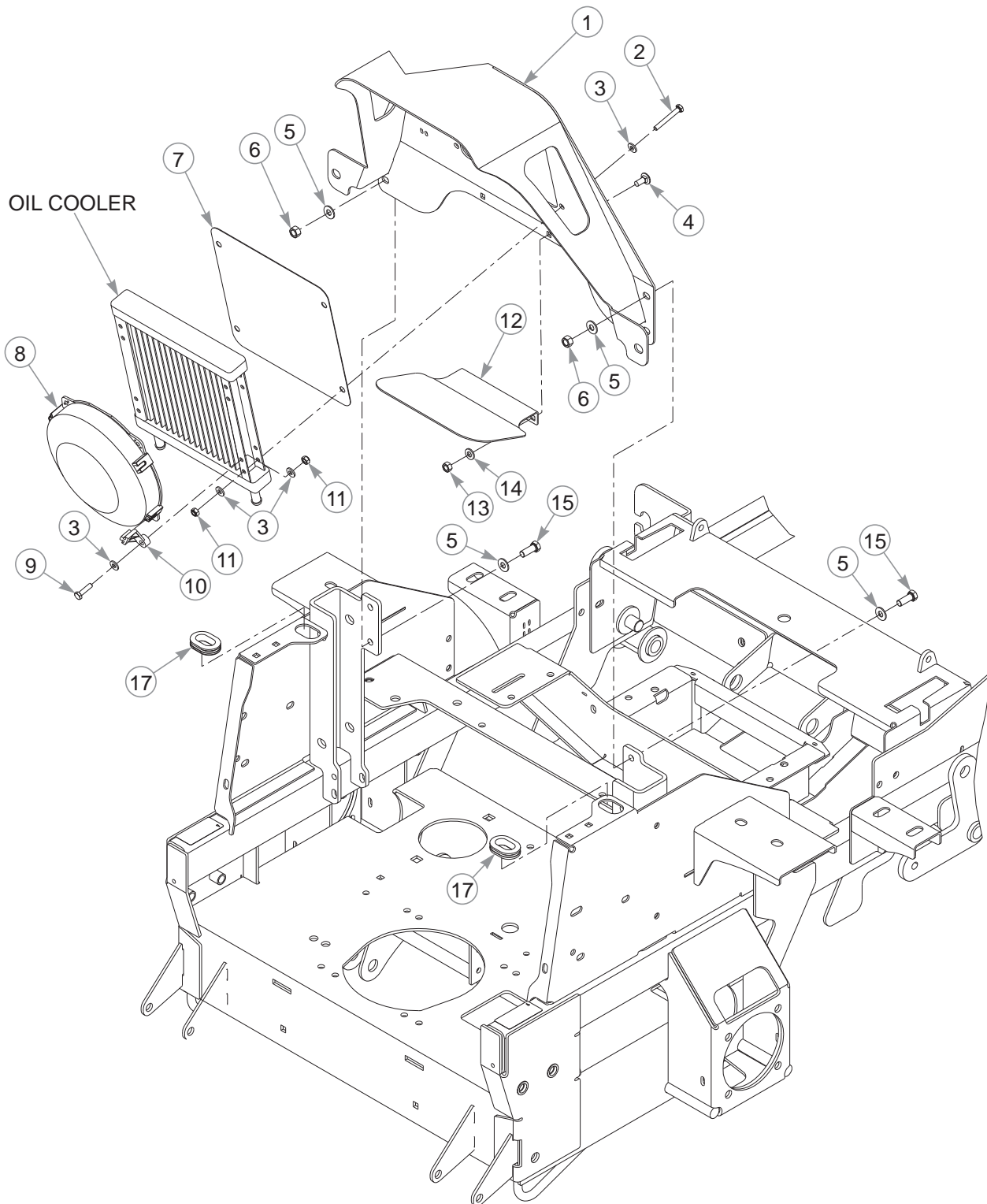

Oil Cooler Mount

INDEX NO.	PART NO.	QTY.	DESCRIPTION
1	117196	1	OIL COOLER MOUNT
2	704163	4	CS .250-20 X 2.00 HX G5 Z
3	768515	16	FW .281 X .625 X .066
4	016253	2	CB .312-18 X .75 FUL ZN
5	767954	8	FW .379 X .813 X .063
6	054502	4	NT .375-16 HX G5 ZNY
7	109401	1	OIL COOLER SCREEN
8	601357	1	8" ELECTRIC FAN
9	056077	4	CS .250-20 X 1.00 HX G5
10	601538	4	ELECTRIC FAN FOOT
11	068551	8	NT .250-20 HX ZY NL
12	115794	1	AIR DEFLECTOR
13	034272	2	NT .312-18 HX G5
14	768523	2	FW .343 X .687 X .051/.080H
15	036244	4	CS .375-16 X 1.00 HX G5
16	000430	5	WIRE TIE (NOT SHOWN)
17	706531	2	GM 1.12 X 1.75 X 1.37 X .12

NOTES:

Pump Drive

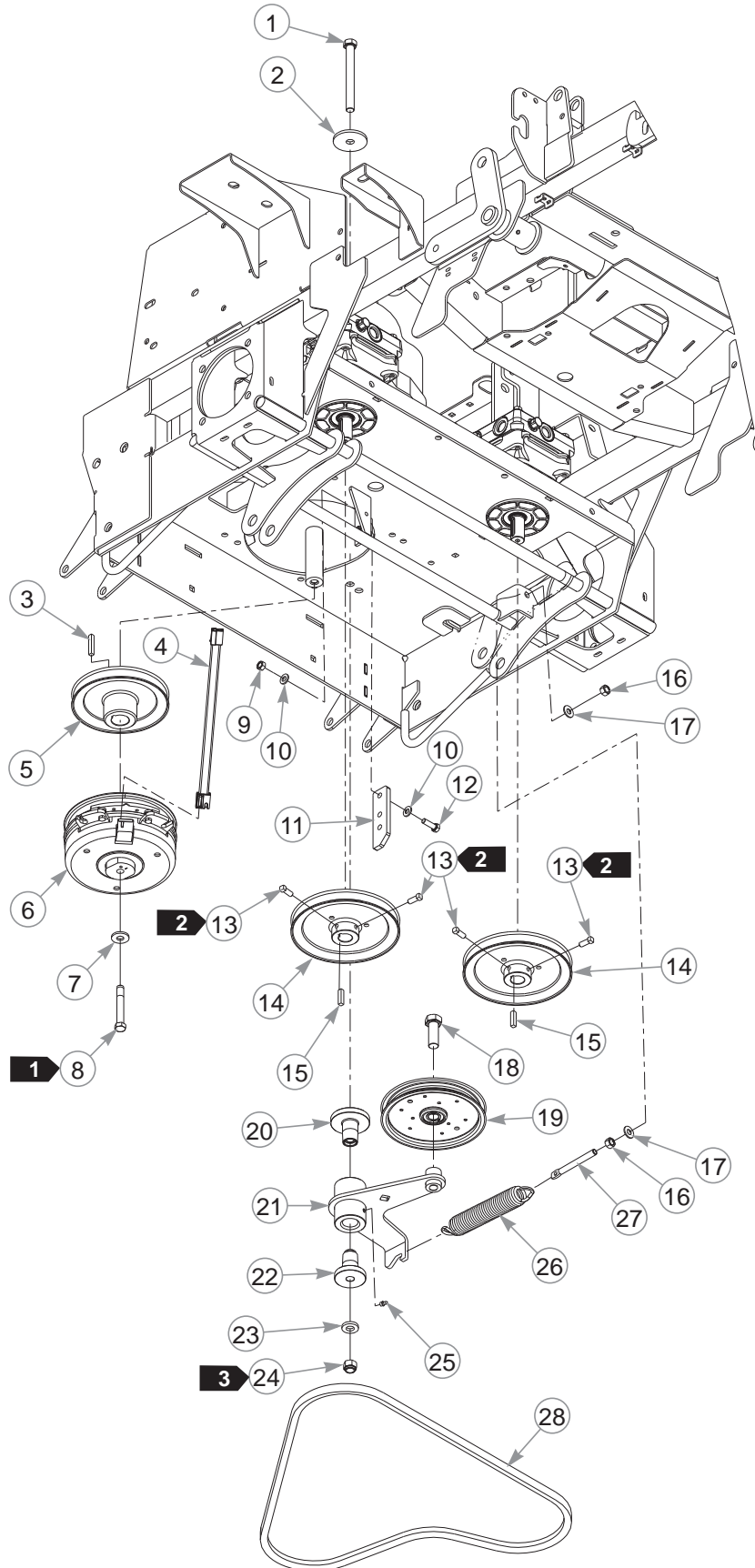

Pump Drive

INDEX NO.	PART NO.	QTY.	DESCRIPTION
1	051151	1	CS .500-13 X 5.00 HX G5
2	344267	1	FW .510 X 2.15 X .187 SPL
3	212076	1	KEY 1/4 SQ X 1.50 LG
4	791251	1	CLUTCH HARNESS PIGTAIL
5	603734	1	PULLEY 6.67 OP X 1.125 SHFT
6	603336K	1	CLUTCH KIT
7	602680	1	FW .453 X 1.12 X .119 HRD
8	785048	1	CS .437-20 X 3.00 HX G5 P85
9	034272	2	NT .312-18 HX G5
10	768523	4	FW .343 X .687 X .051/.080H
11	113347	1	CLUTCH ANCHOR
12	036236	2	CS .312-18 X 1.00 HX G5
13	083196	4	SS .312-18 X .75 SQ-HD
14	602754	2	PULLEY 7.35 OP X .875 SHFT
15	210146	2	KEY 1/4 SQ X 1.12 LONG
16	054502	2	NT .375-16 HX G5 ZNY
17	767954	2	FW .379 X .813 X .063
18	025007	1	CS .625-11 X 1.75 HX G5
19	603783	1	6" IDLER PULLEY
20	602880	1	IDLER PIVOT BUSHING
21	115536	1	TENSIONER
22	602879	1	IDLER PIVOT BUSHING
23	767962	1	FW .531 X 1.063 X .175
24	781567	1	NT .500-13 HX G8 ZY NL
25	015495	1	GREASE FITTING STRAIGHT
26	601016	1	IDLER SPRING
27	601486	1	EB, .375-16 X 3.00 FULL THD
28	604208	1	BELT, 64.89" B B-SECTION

NOTES:

1. Torque to 45–48 ft-lbs. Replace (do not reuse) the cap screw if it is removed or loosened. Use only hand tools to install this fastener.
2. Torque to 12–15 ft-lbs.
3. Torque to 71–75 ft-lbs. The tensioner should pivot freely.

Steering

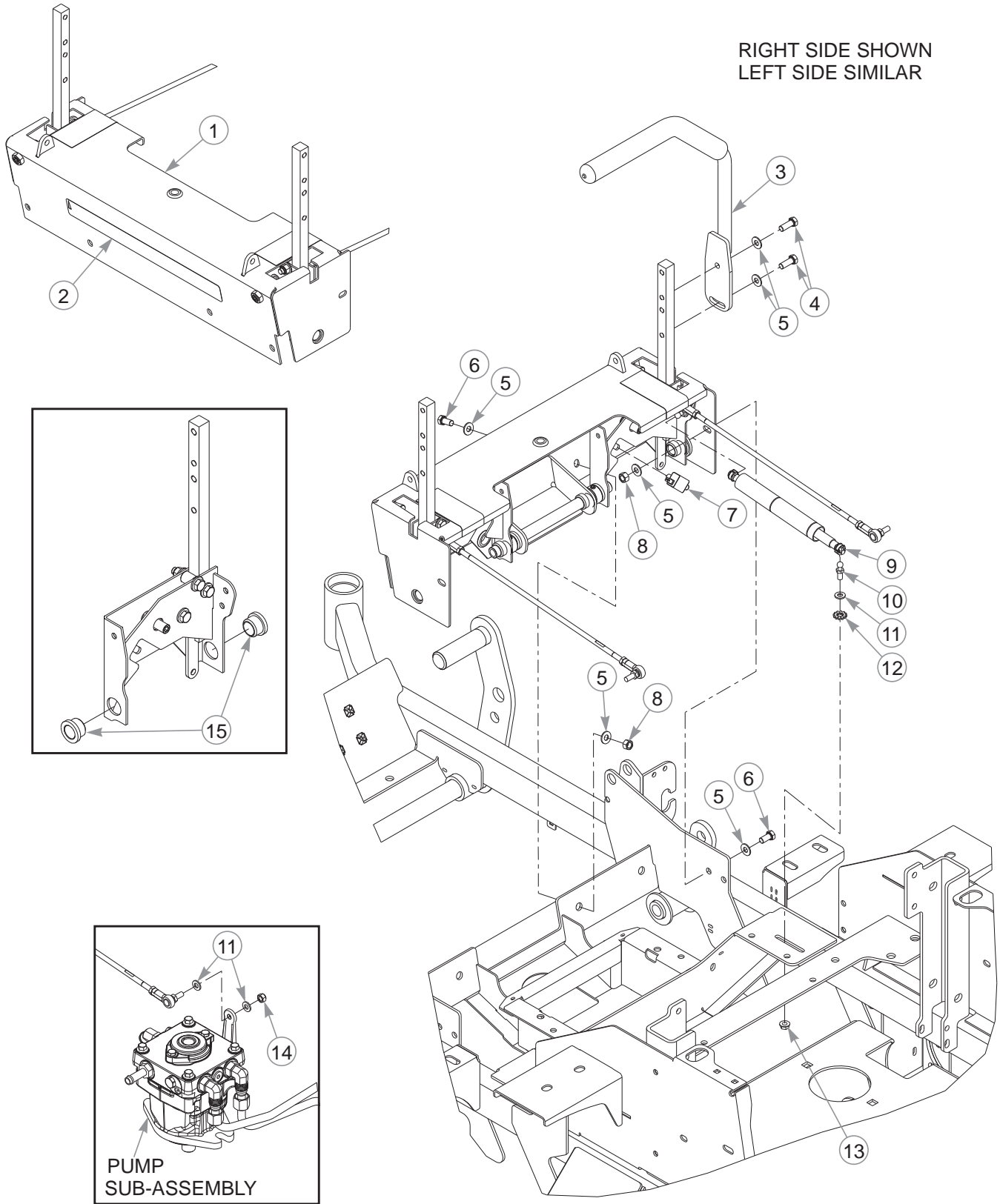

Steering

INDEX NO.	PART NO.	QTY.	DESCRIPTION
1	N/A	1	STEERING COVER ASSEMBLY
2	605670	1	SUPER Z DECAL
3	109839	2	HANDLE (WITH GRIP)
	781260	2	GRIP
4	036244	4	CS .375-16 X 1.00 HX G5
5	767954	16	FW .379 X .813 X .063
6	055822	6	CS .375-16 X .75 HX G5
7	601087	2	SWITCH
8	054502	6	NT .375-16 HX G5 ZNY
9	795351	2	DAMPER
10	781922	2	BALL STUD
11	768523	6	FW .343 X .687 X .051/.080H
12	029876	2	LW .325 INT-EXT TOOTH
13	016832	2	NT .312-18 HX G5 FLK ZNYC
14	023655	2	NT .312-24 HX G5 NL ZN
15	781153	4	BUSHING

NOTES:

Steering Assembly

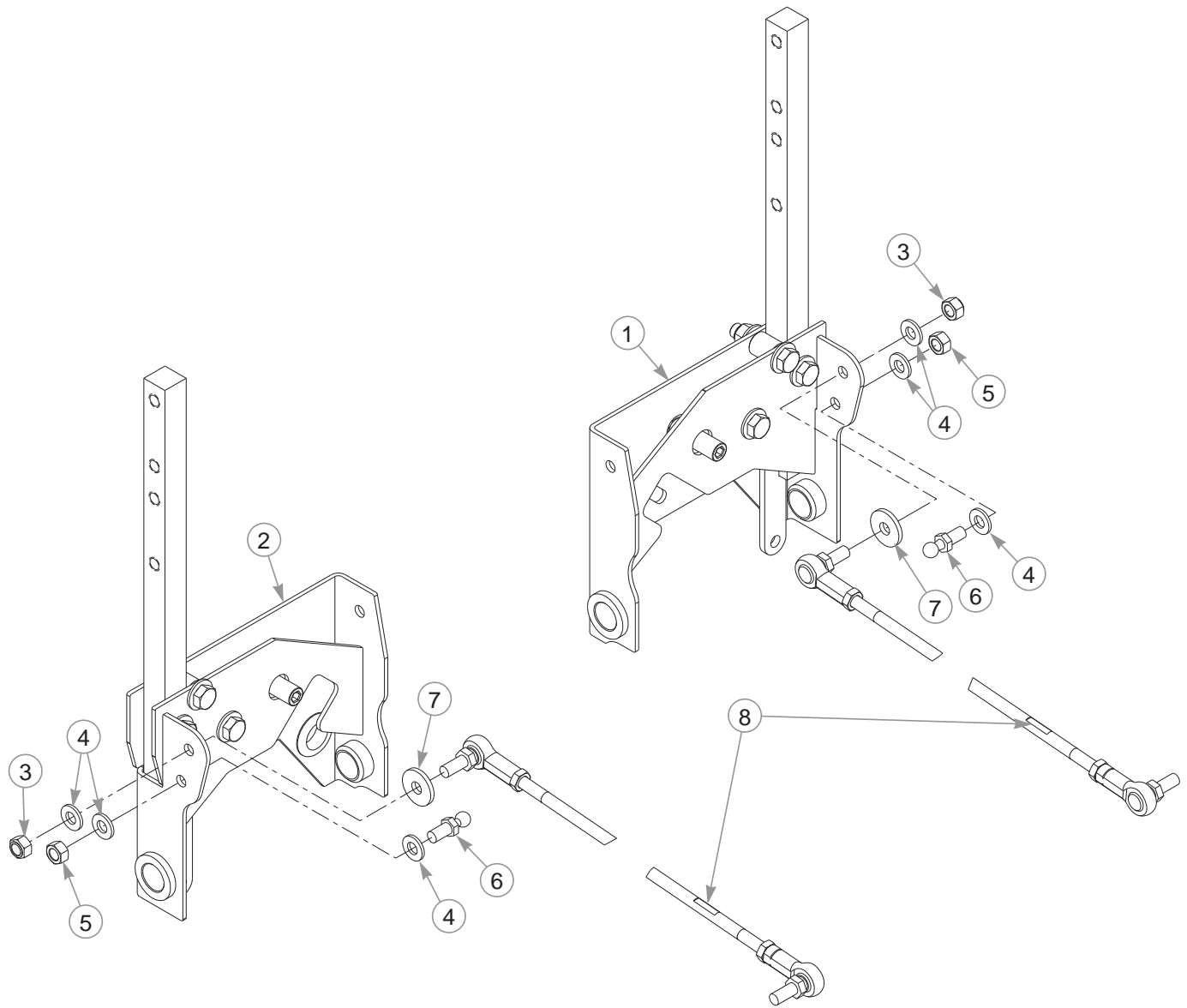

Steering Assembly

INDEX NO.	PART NO.	QTY.	DESCRIPTION
1	N/A	1	RS STEERING BOX ASSEMBLY
2	N/A	1	LS STEERING BOX ASSEMBLY
3	023655	2	NT .312-24 HX NL G5
4	768523	6	FW .343 X .687 X .051/.080H
5	034272	2	NT .312-18 HX G5
6	781922	2	BALL STUD
7	712927	2	FW .344 X 1.00 X .12 HRD Z
8	781286	2	PUMP ROD ADJUSTER

NOTES:

Steering Cover Assembly

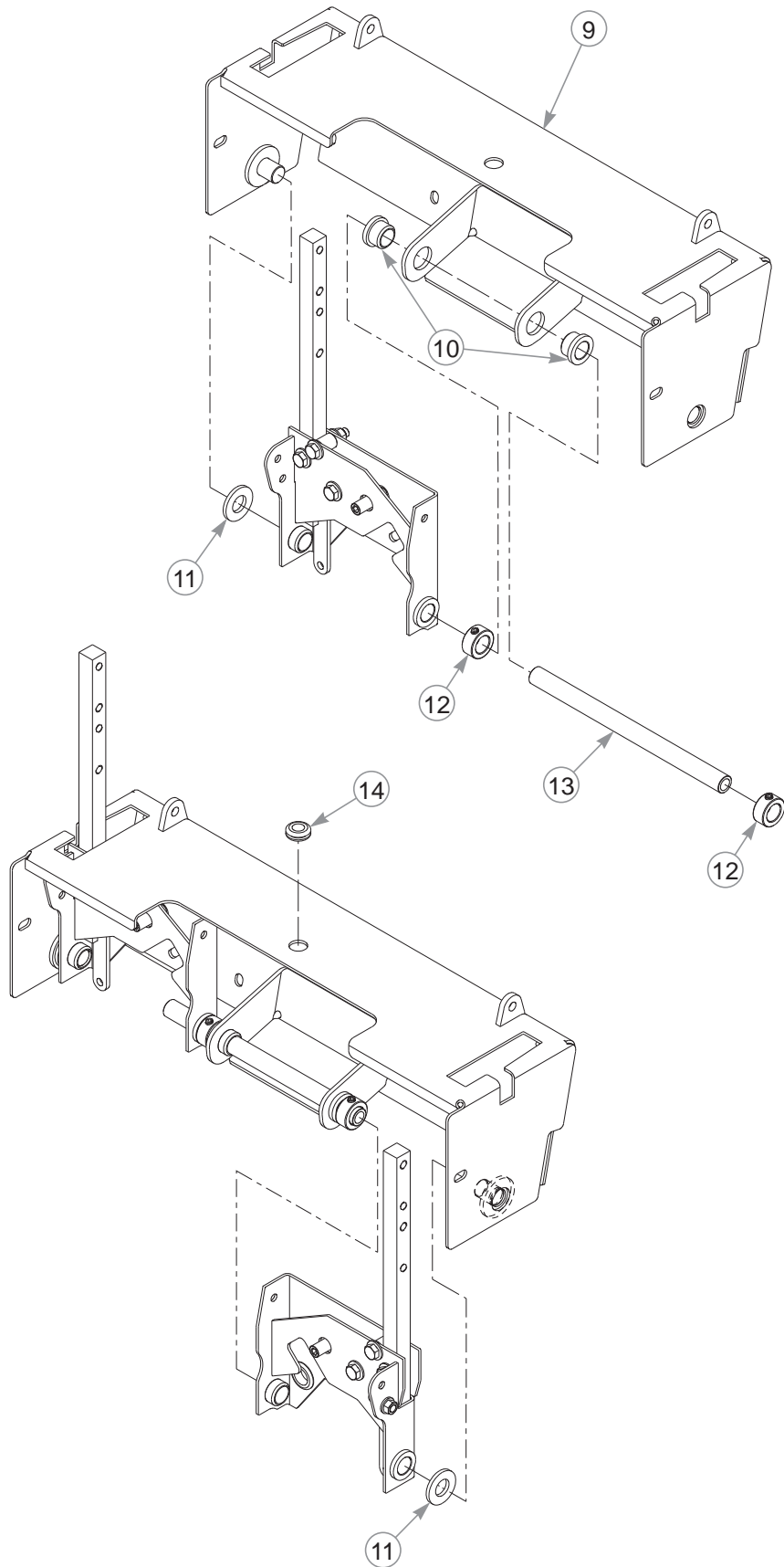

Steering Cover Assembly

INDEX NO.	PART NO.	QTY.	DESCRIPTION
9	551752	1	STEERING COVER (WITH DECAL)
10	781153	2	BUSHING
11	603078	2	FW .750 X 1.50 X .156 ZN
12	784439	2	LOCK COLLAR .757 ID
13	113007	1	STEER PIVOT TUBE
14	080358	1	GM .50 X 1.00 X .75 X .12

NOTES:

Steering Cover Assembly

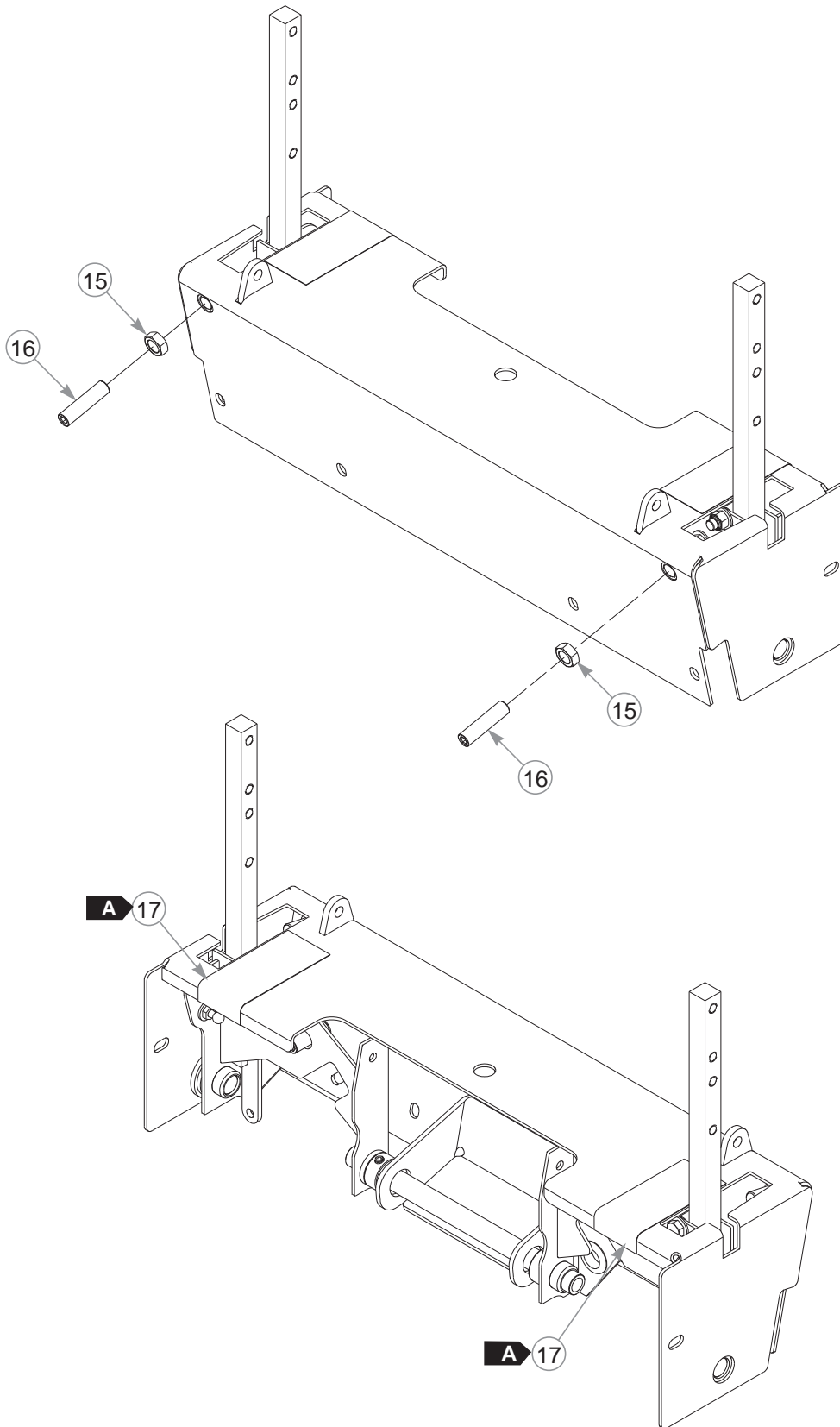

Steering Cover Assembly

INDEX NO.	PART NO.	QTY.	DESCRIPTION
15	053199	2	NT .500-13 HX JAM ZNYC
16	797738	2	SS .500-13 X 2.00 SH
17	722199	11"	WEAR TAPE

NOTES:

WEAR TAPE LENGTH	
	5.5" ± 0.3"

Left Steering Box Assembly

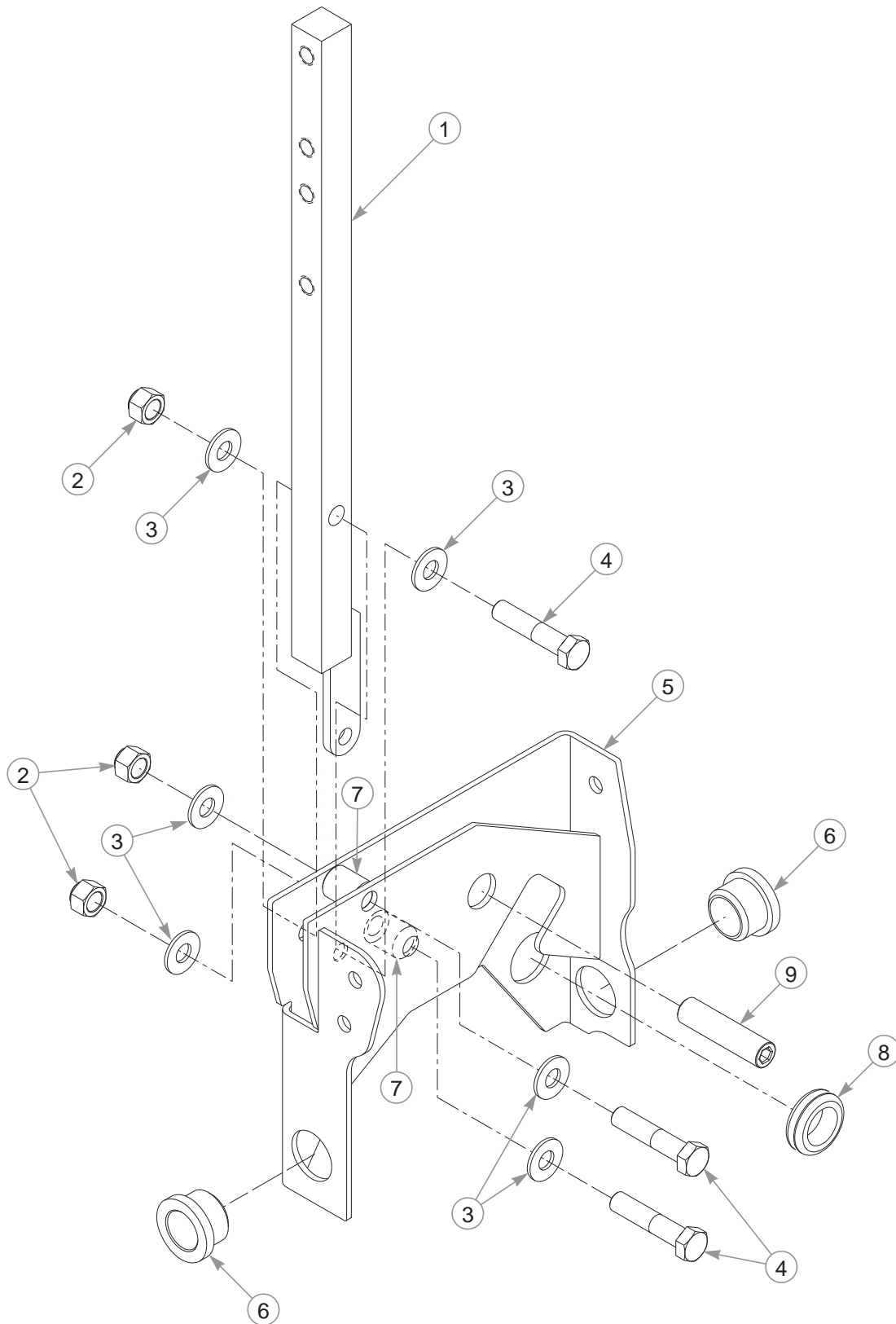

Left Steering Box Assembly

INDEX NO.	PART NO.	QTY.	DESCRIPTION
1	113575	1	STEERING ARM
2	086660	3	NT .375-16 HX G5 ZY NL
3	767954	6	FW .379 X .813 X .063
4	705178	3	CS .375-16 X 1.75 HX G5
5	112899	1	LS STEERING BOX
6	781153	2	BUSHING
7	348862	2	STEERLEVER BUSHING
8	047456	1	GM .750 X .188 X 1.00 X .12
9	797738	1	SS .500-13 X 2.00 SH ZY

NOTES:

Right Steering Box Assembly

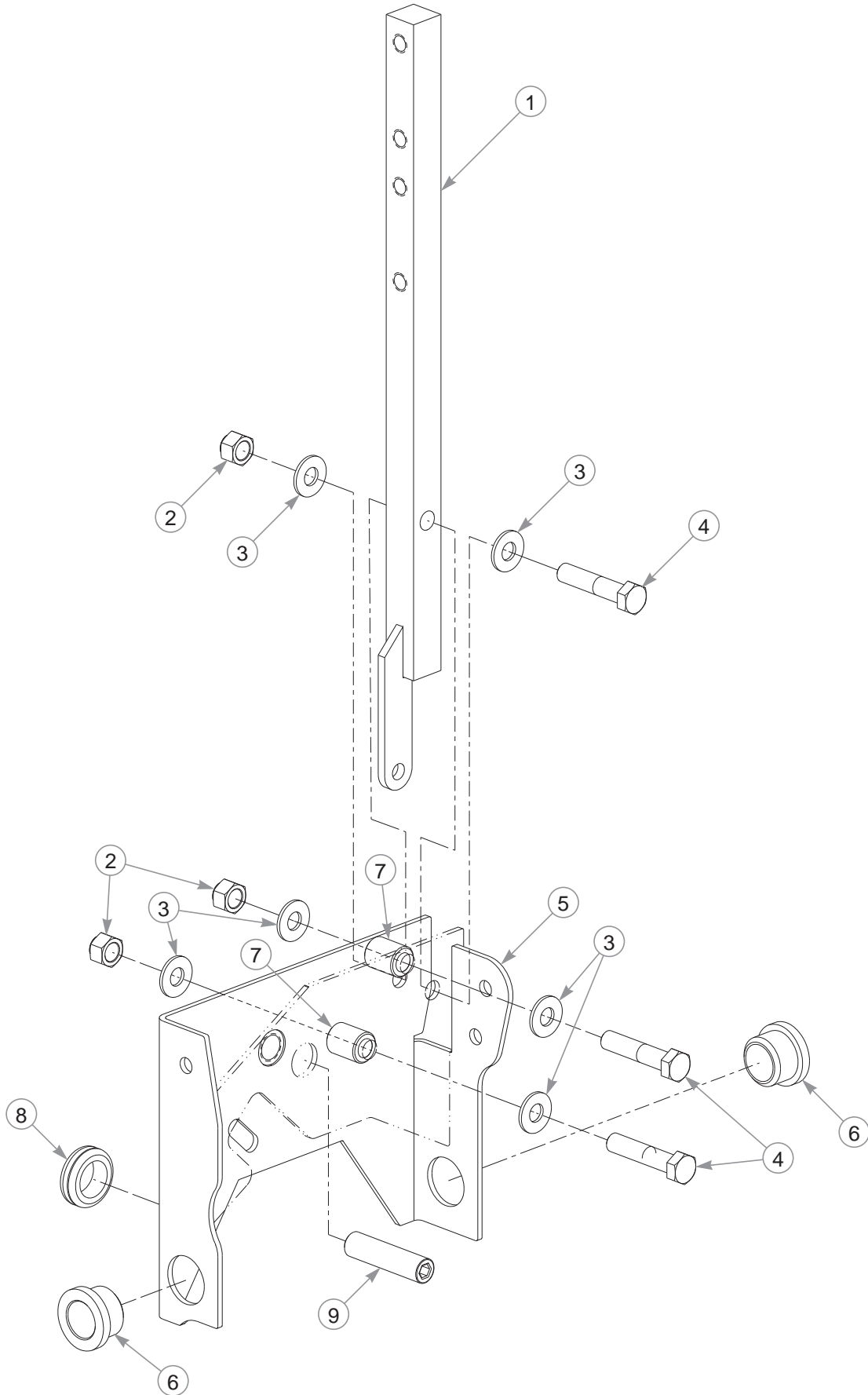

Right Steering Box Assembly

INDEX NO.	PART NO.	QTY.	DESCRIPTION
1	113575	1	STEERING ARM
2	086660	3	NT .375-16 HX G5 ZY NL
3	767954	6	FW .379 X .813 X .063
4	705178	3	CS .375-16 X 1.75 HX G5
5	112898	1	RS STEERING BOX
6	781153	2	BUSHING
7	348862	2	STEERLEVER BUSHING
8	047456	1	GM .750 X .188 X 1.00 X .12
9	797738	1	SS .500-13 X 2.00 SH ZY

NOTES:

Brake

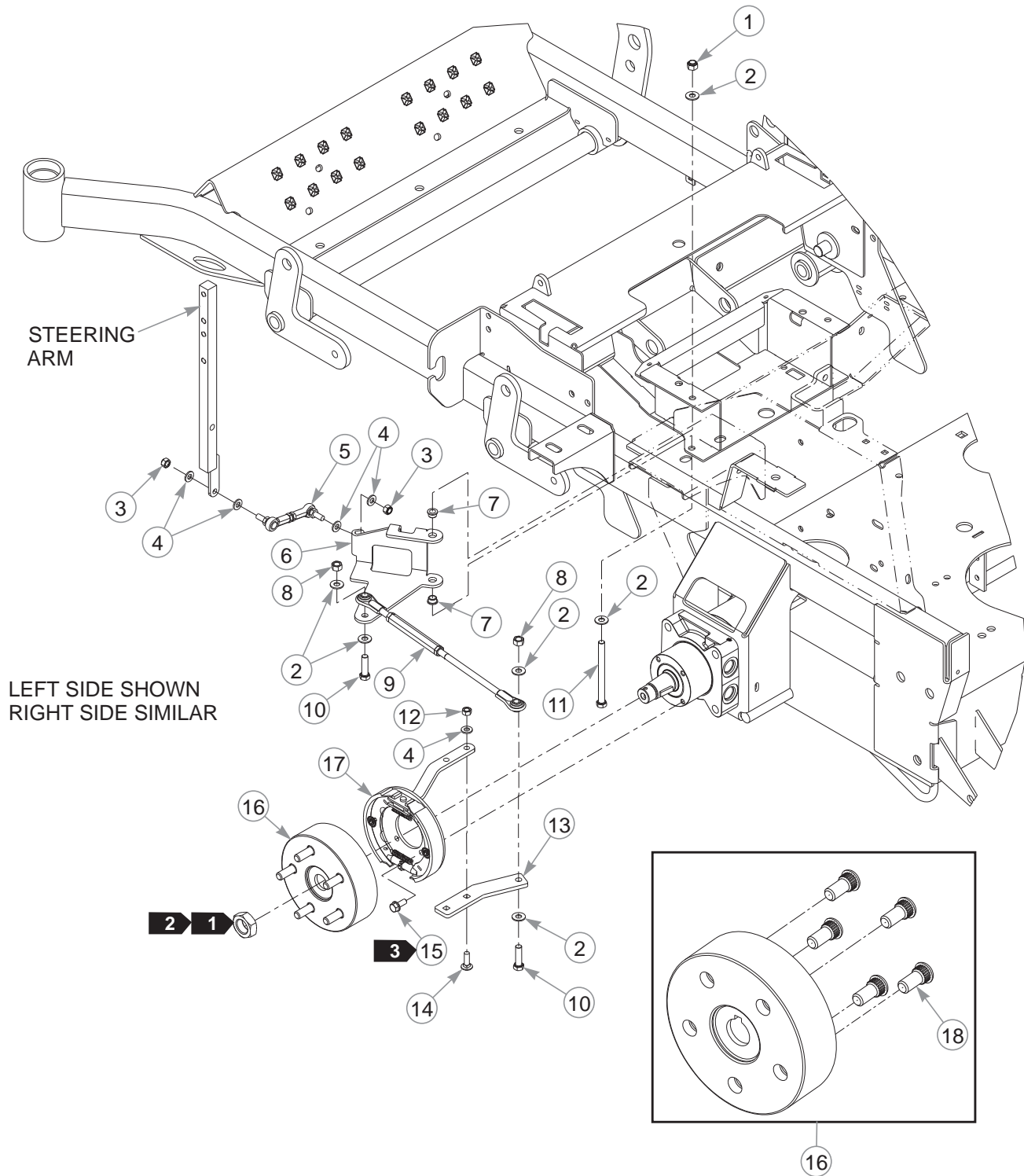

Brake

INDEX NO.	PART NO.	QTY.	DESCRIPTION
1	086660	2	NT .375-16 HX ZY NL
2	767954	12	FW .379 X .813 X .063
3	023655	4	NT .312-24 HX NL G5
4	768523	12	FW .343 X .687 X .051/.080H
5	781583	2	BRAKE ROD ASSEMBLY
6	112907	1	LS BRAKE BELLCRANK
	112906	1	RS BRAKE BELLCRANK (NOT SHOWN)
7	765339	4	BUSHING
8	054502	4	NT .375-16 HX G5 ZNY
9	350397	2	BRAKE LINK TURNBUCKLE
10	005116	4	CS .375-16 X 1.375 HX G5
11	052514	2	CS .375-16 X 4.50 HX G5
12	034272	4	NT .312-18 HX G5
13	111309	2	BRAKE ARM
14	037887	4	CB .312-18 X 1.00 FULL ZN
15	604461	8	CS .312-18 X .75 HX G8 FLK
16	602384	2	HUB ASSEMBLY (WITH STUDS)
17	602383	2	BRAKE ASSEMBLY
18	606124	5	WHEEL STUD LUG 1/2-20

NOTES:

1. Included with the wheel motor.
2. Torque to 220–240 ft-lbs.
3. Torque to 27 ft-lbs. Replace (do not reuse) the cap screw if it is removed or loosened. Use only hand tools to install this fastener.

Section 4

Wheel & Tire	4-2
Front Wheel Assembly.	4-4
Drive Wheel Breakdown	4-6

Wheel & Tire

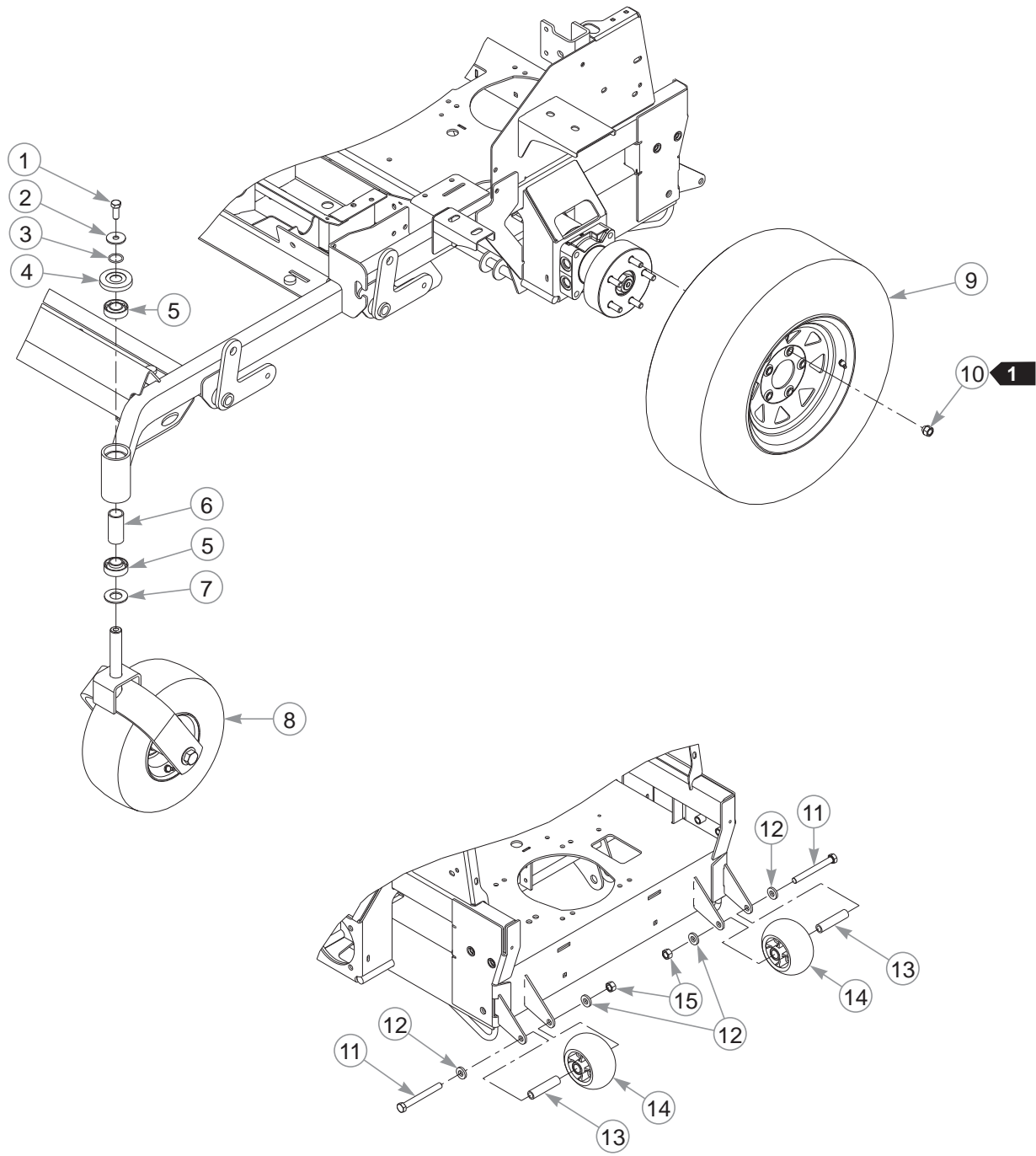

Wheel & Tire

INDEX NO.	PART NO.	QTY.	DESCRIPTION
1	705954	2	CS .500-13 X 1.25 HX G5 ZN
2	798603	2	FW .515 X 1.65 X .125 HD ZY
3	601375	2	O-RING, SAE-14
4	603153	2	DUST CAP
5	784223	4	BEARING
6	387035	2	SPACER 1.07 X 1.312 X 2.79
7	603164	2	DISC BEARING
8	N/A	2	FRONT TIRE SUB-ASSEMBLY
9	782078	2	TIRE/WHEEL ASSEMBLY 24 X 9.5 X 12 (54" MOWERS)
	601238	2	TIRE/WHEEL ASSEMBLY 24 X 12 X 12 (60" MOWERS)
	784058	2	TIRE/WHEEL ASSEMBLY 24 X 12 X 12 (66"/72" MOWERS)
10	061077	10	WHEEL NUT
11	068239	2	CS .500-13 X 4.50 HX G5
12	767962	4	FW .531 X 1.063 X .175
13	602345	2	SPACER 3.22
14	602263	2	PLASTIC WHEEL
15	008193	2	NT .500-13 HX G5 ZNYC

NOTES:

1. Torque to 65–75 ft-lbs.

Front Wheel Assembly

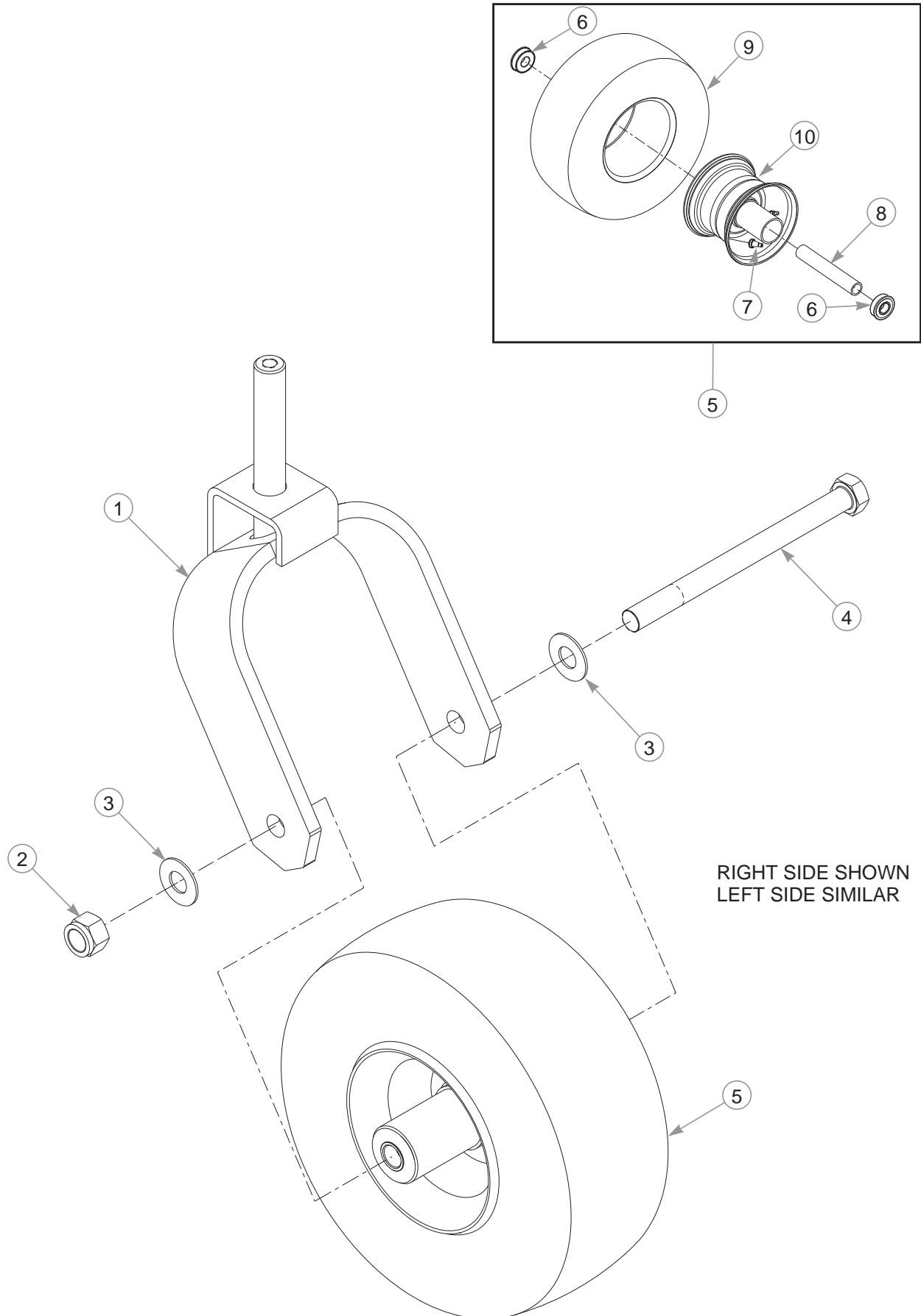

Front Wheel Assembly

INDEX NO.	PART NO.	QTY.	DESCRIPTION
1	116890	1	FORK, HEAVY DUTY
	113621	1	FORK
2	061101	1	NT .750-10 HX ZY NL
3	025296	2	FW .760 X 1.625 X .08 ZNYC
4	041475	1	CS .750-10 X 9.50 HX ZY
5	604898	1	TIRE/WHEEL ASSEMBLY 13 X 6.50
6	039677	2	BEARING
7	019521	1	VALVE STEM
8	782771	1	BEARING SPACER
9	604843	1	TIRE
10	747832	1	WHEEL

NOTES:

Drive Wheel Breakdown

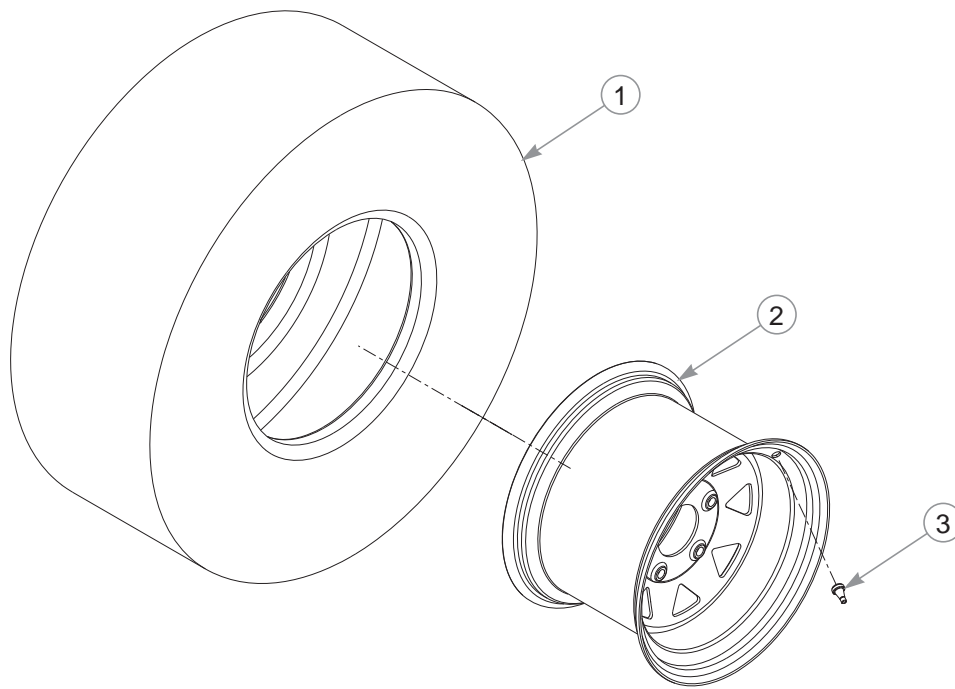

782078 TIRE/WHEEL ASSEMBLY (54" MOWER)

INDEX NO.	PART NO.	QTY.	DESCRIPTION
1	782284	1	TIRE 24 X 9.50-12
2	782086	1	WHEEL 12 X 7
3	019521	1	VALVE STEM

601238 TIRE/WHEEL ASSEMBLY (60" MOWER)

INDEX NO.	PART NO.	QTY.	DESCRIPTION
1	781245	1	TIRE 24 X 12-12
2	796250	1	WHEEL 12 X 8.50
3	019521	1	VALVE STEM

784058 TIRE/WHEEL ASSEMBLY (66"/72" MOWERS)

INDEX NO.	PART NO.	QTY.	DESCRIPTION
1	781245	1	TIRE 24 X 12-12
2	784066	1	WHEEL 12 X 8.50
3	019521	1	VALVE STEM

NOTES:

Section 5

Engine, Kawasaki FX850V	5-2
Engine, Kawasaki FX1000V	5-6
Engine Service Parts, Kawasaki	5-8
Engine, Kohler	5-10
Engine Service Parts, Kohler	5-14
Fuel System, Kawasaki	5-16
Fuel System, Kohler—Without Carbon Canister	5-18
Fuel System, Kohler—With Carbon Canister	5-20
Vapor System, Kohler—With Carbon Canister	5-22
Fuel Tank Service Parts	5-24

Engine, Kawasaki FX850V

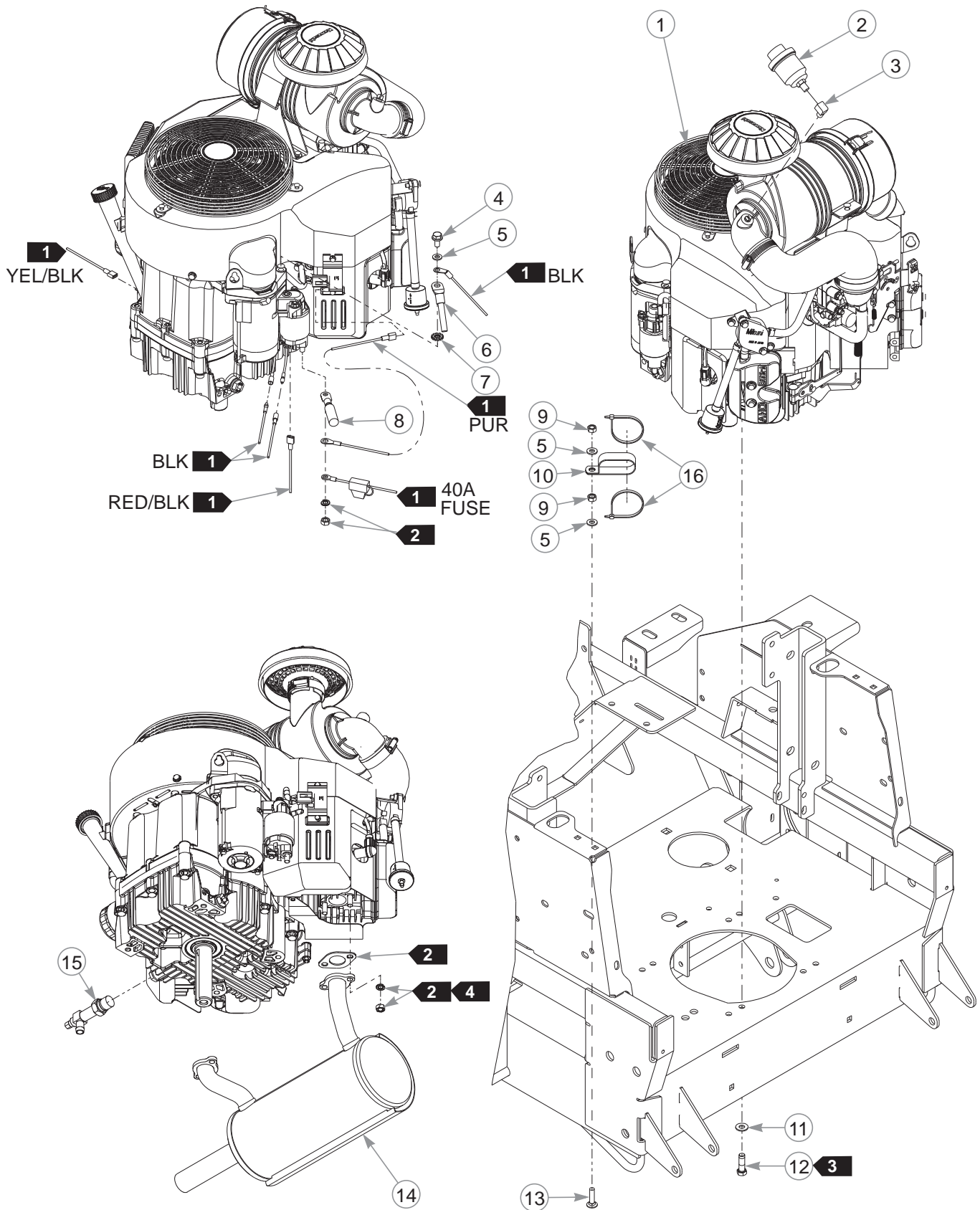

Engine, Kawasaki FX850V

INDEX NO.	PART NO.	QTY.	DESCRIPTION
1	N/A	1	KAWASAKI FX850V ENGINE
2	788943	1	AIR FILTER INDICATOR
3	601216	1	ELBOW STREET FITTING
4	720516	1	CS M8 X 1.25 X 16 HX FL 10.9
5	768523	6	FW .343 X .687 X .051/.080H
6	605155	1	NEGATIVE BATTERY CABLE
7	029876	1	LW .312 INT-EXT TOOTH
8	604029	1	POSITIVE BATTERY CABLE
9	034272	2	NT .312-18 HX G5
10	045088	1	HOSE CLAMP
11	767954	4	FW .379 X .813 X .063
12	602580	4	CS .375-16 X 1.25 HX G8 P85
13	602827	1	CB .312-18 X 1.25 ZNYC
14	603012	1	MUFFLER
15	796524	1	OIL DRAIN VALVE
16	000331	4	WIRE TIE

NOTES:

1. Part of the wire harness.
2. Supplied with the engine.
3. Torque to 12 ft-lbs plus 60° rotation of the cap screw head. Replace (do not reuse) the cap screw if it is removed or loosened. Use only hand tools to install this fastener.
4. Torque to 22 ft-lbs.

Engine, Kawasaki FX850V

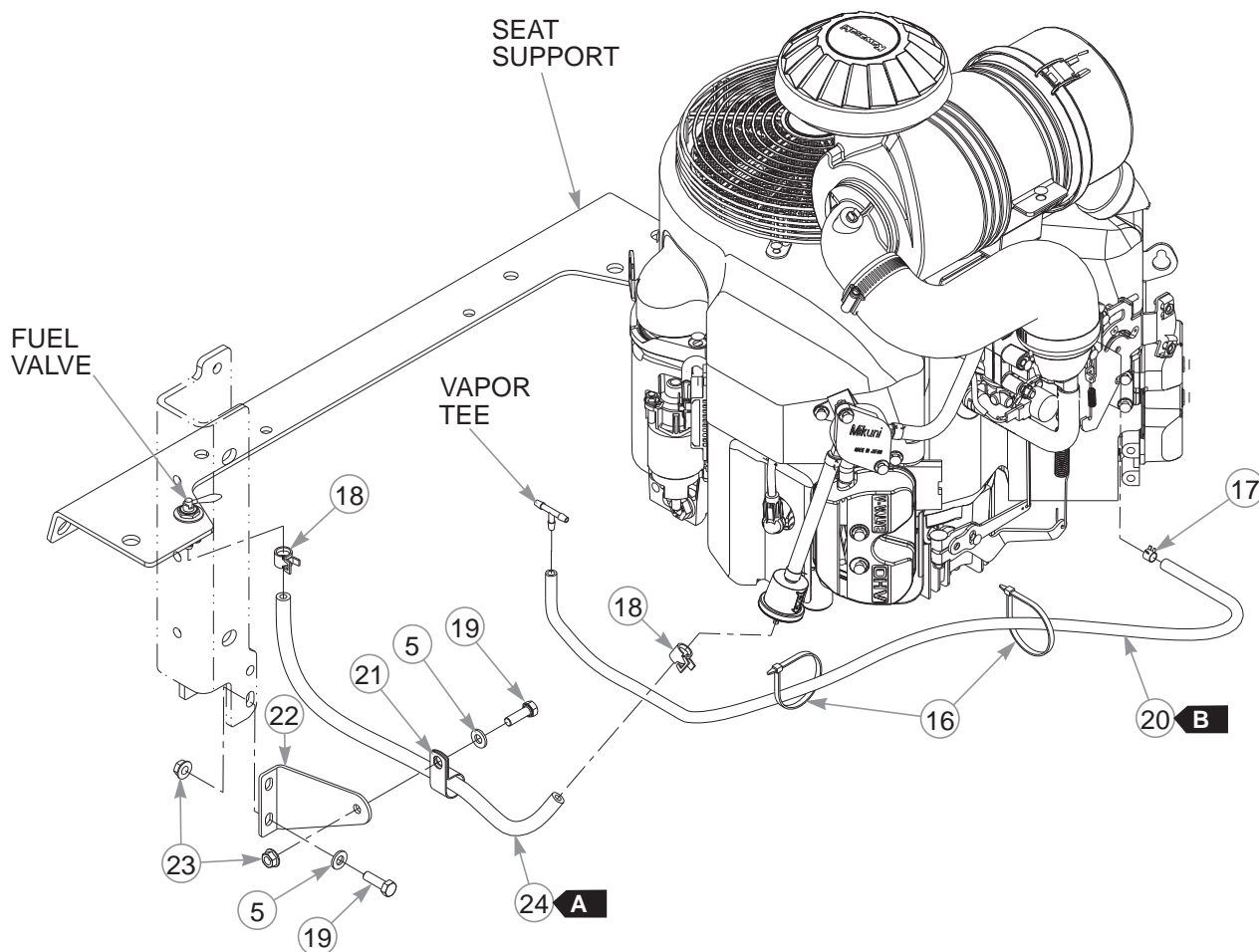

INDEX NO.	PART NO.	QTY.	DESCRIPTION
17	603112	1	CLAMP, 3/16"
18	000323	2	HOSE CLAMP
19	036236	3	CS .312-18 X 1.00 HX G5
20	603326	34"	3/16" VAPOR LINE
21	043570	1	LOOP CLAMP
22	114578	1	BRACE
23	016832	3	NT .312-18 HX FLK ZNYC
24	015818	17"	1/4" FUEL LINE

NOTES:

FUEL & VAPOR LINE LENGTHS		
A	17"	VALVE TO ENGINE (FUEL)
B	34"	TEE TO ENGINE (VAPOR)

This page intentionally left blank.

Engine, Kawasaki FX1000V

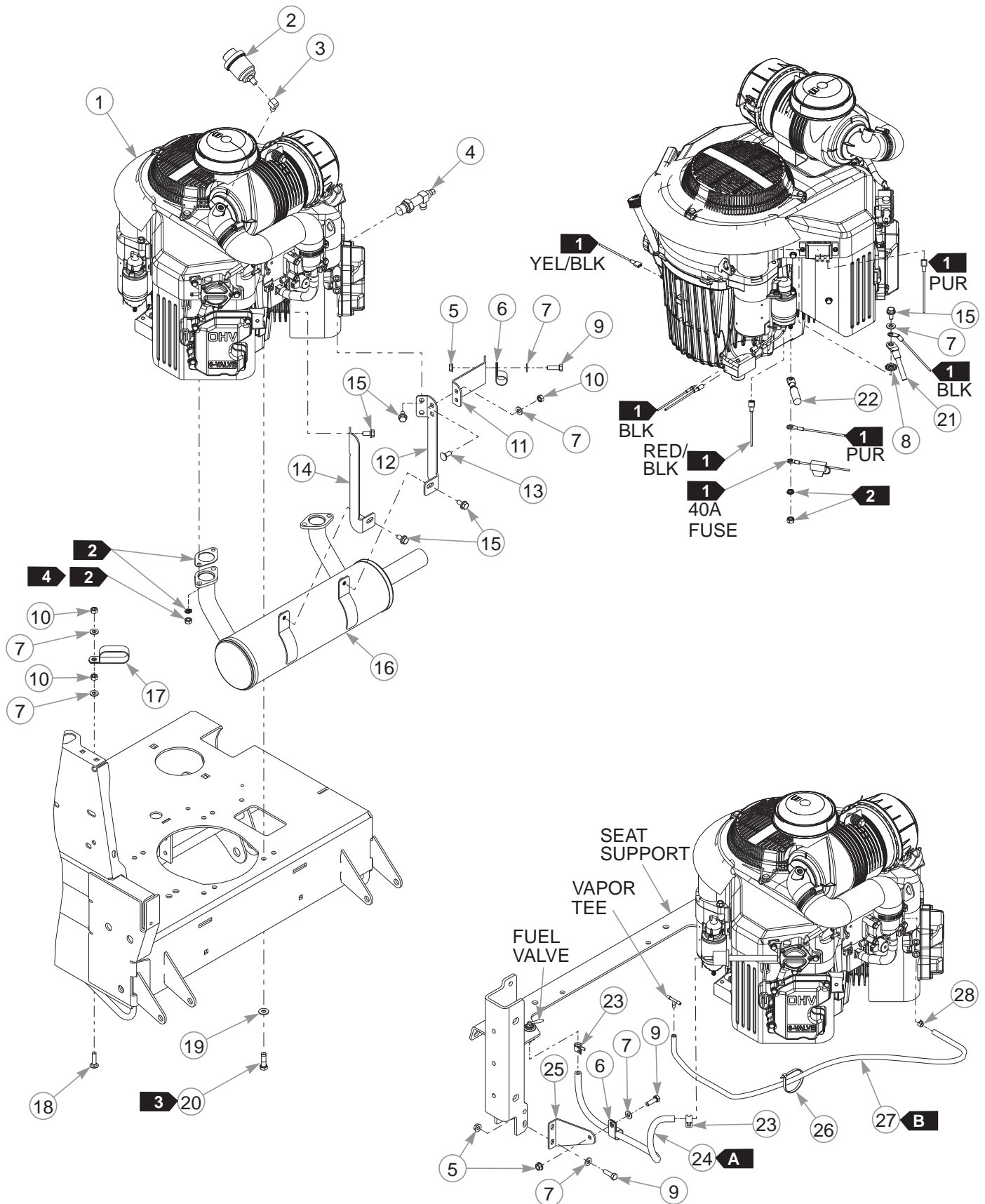

Engine, Kawasaki FX1000V

INDEX NO.	PART NO.	QTY.	DESCRIPTION
1	N/A	1	KAWASAKI FX1000V ENGINE
2	788943	1	AIR FILTER INDICATOR
3	601216	1	ELBOW STREET FITTING
4	796524	1	OIL DRAIN VALVE
5	016832	4	NT .312-18 HX FLK
6	043570	2	LOOP CLAMP
7	768523	9	FW .343 X .687 X .051/.080H
8	029876	1	LW .312 INT-EXT TOOTH
9	036236	4	CS .312-18 X 1.00 HX G5
10	034272	4	NT .312-18 HX G5
11	606205	1	THROTTLE WIRE BRACKET
12	122504	1	RS MUFFFLER BRACKET
13	016253	2	CB .312-18 X .75 FUL ZN
14	122505	1	LS MUFFLER BRACKET
15	720516	7	CS M8 X 1.25 X 16 HX FL 10.9
16	606040	1	MUFFLER
17	045088	1	HOSE CLAMP
18	602827	1	CB .312-18 X 1.25 ZNYC
19	767954	4	FW .379 X .813 X .063
20	602580	4	CS .375-16 X 1.25 HX G8 P85
21	605155	1	NEGATIVE BATTERY CABLE
22	604029	1	POSITIVE BATTERY CABLE
23	000323	2	HOSE CLAMP
24	015818	14"	1/4" FUEL LINE
25	114578	1	BRACE
26	000331	5	WIRE TIE
27	603326	34"	3/16" VAPOR LINE
28	603112	1	3/16" HOSE CLAMP

NOTES:

FUEL & VAPOR LINE LENGTHS		
A	14"	VALVE TO ENGINE (FUEL)
B	34"	TEE TO ENGINE (VAPOR)

1. Part of the wire harness.
2. Supplied with the engine.
3. Torque to 12 ft-lbs plus 60° rotation of the cap screw head. Replace (do not reuse) the cap screw if it is removed or loosened. Use only hand tools to install this fastener.
4. Torque to 22 ft-lbs.

Engine Service Parts, Kawasaki

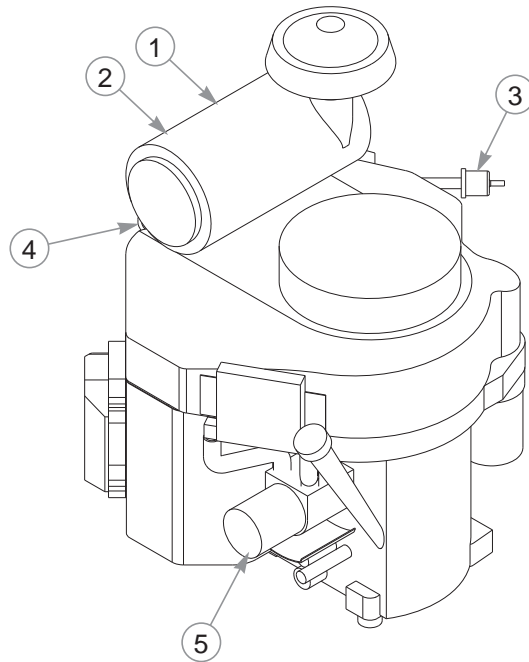

INDEX NO.	PART NO.	QTY.	DESCRIPTION
1	785261	1	MAIN AIR FILTER
2	785279	1	SAFETY AIR FILTER
3	068478	1	IN-LINE FUEL FILTER
4	763318	1	VACUATOR VALVE
5	603138	1	OIL FILTER

NOTES:

This page intentionally left blank.

Engine, Kohler

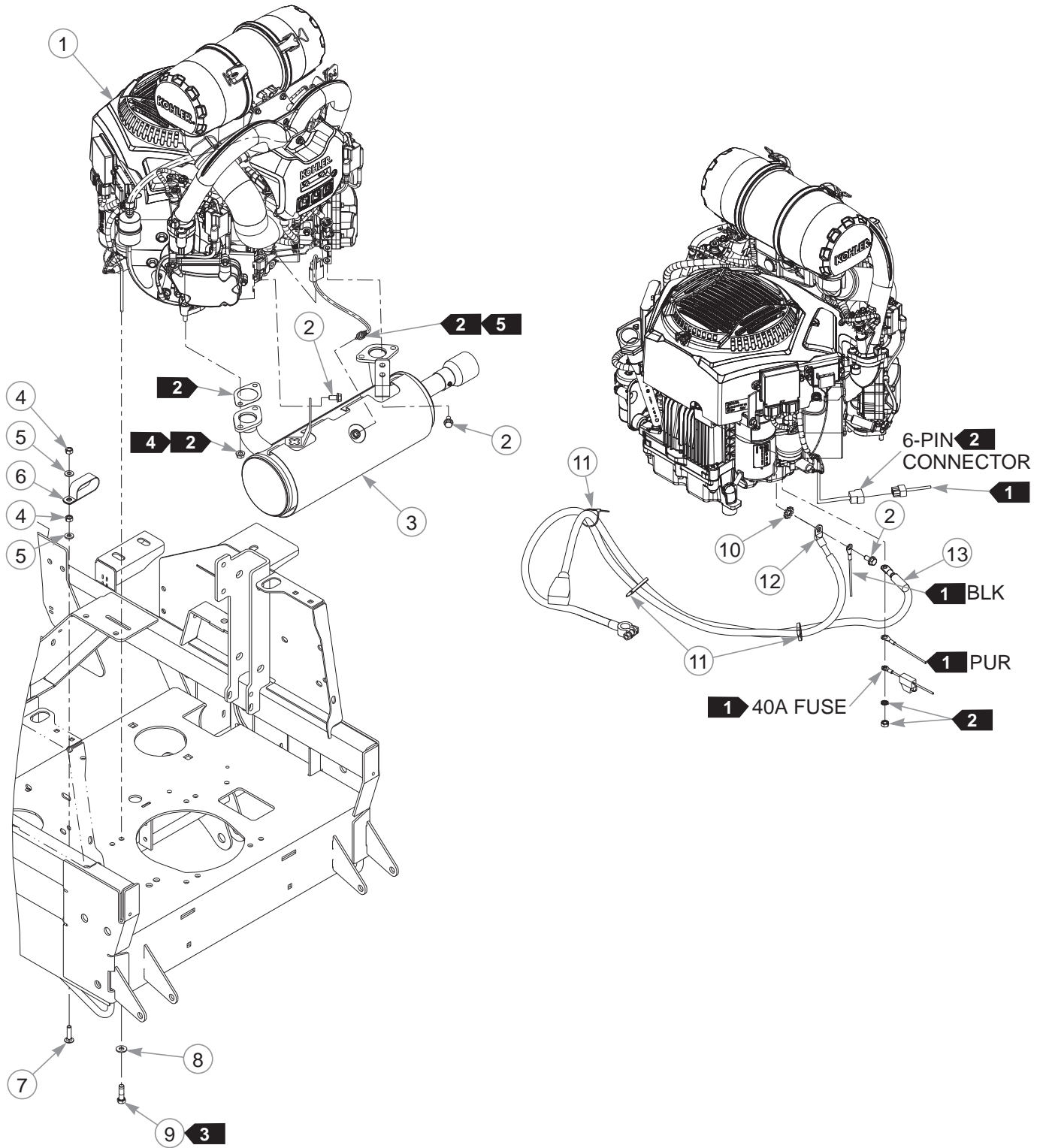

Engine, Kohler

INDEX NO.	PART NO.	QTY.	DESCRIPTION
1	N/A	1	KOHLER ECV860 & ECV880 ENGINE
2	720516	3	CS M8 X 1.25 X 16 HX FL 10.9
3	605828	1	MUFFLER
4	034272	2	NT .312-18 HX G5
5	768523	5	FW .343 X .687 X .051/.080H
6	045088	1	HOSE CLAMP
7	602827	1	CB .312-18 X 1.25 ZNYC
8	767954	4	FW .379 X .813 X .063
9	602580	4	CS .375-16 X 1.25 HX G8 P85
10	793885	1	LW .375 INT-EXT TOOTH
11	000331	4	WIRE TIE
12	605155	1	NEGATIVE BATTERY CABLE
13	604029	1	POSITIVE BATTERY CABLE

NOTES:

1. Part of the wire harness.
2. Supplied with the engine.
3. Torque to 12 ft-lbs plus 60° rotation of the cap screw head. Replace (do not reuse) the cap screw if it is removed or loosened. Use only hand tools to install this fastener.
4. Torque to 20 ft-lbs.
5. Torque to 30 ft-lbs.

Engine, Kohler

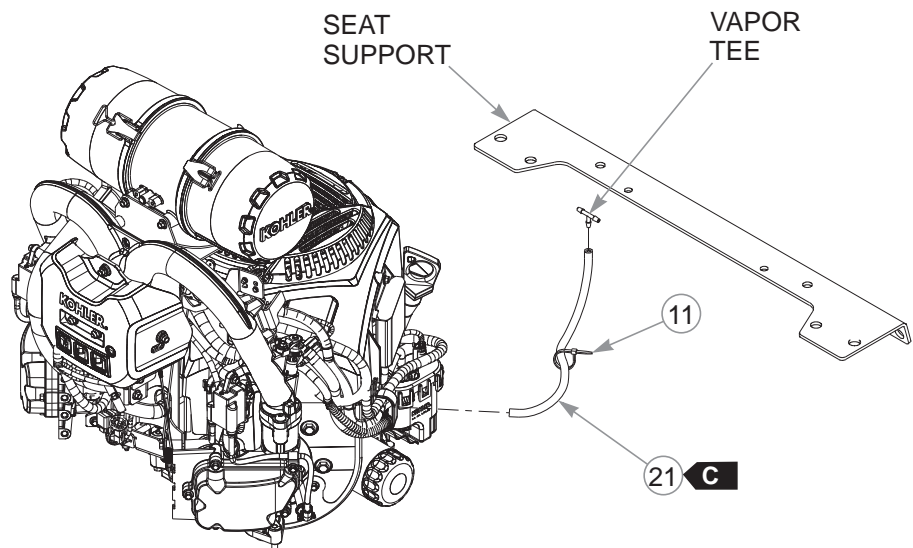
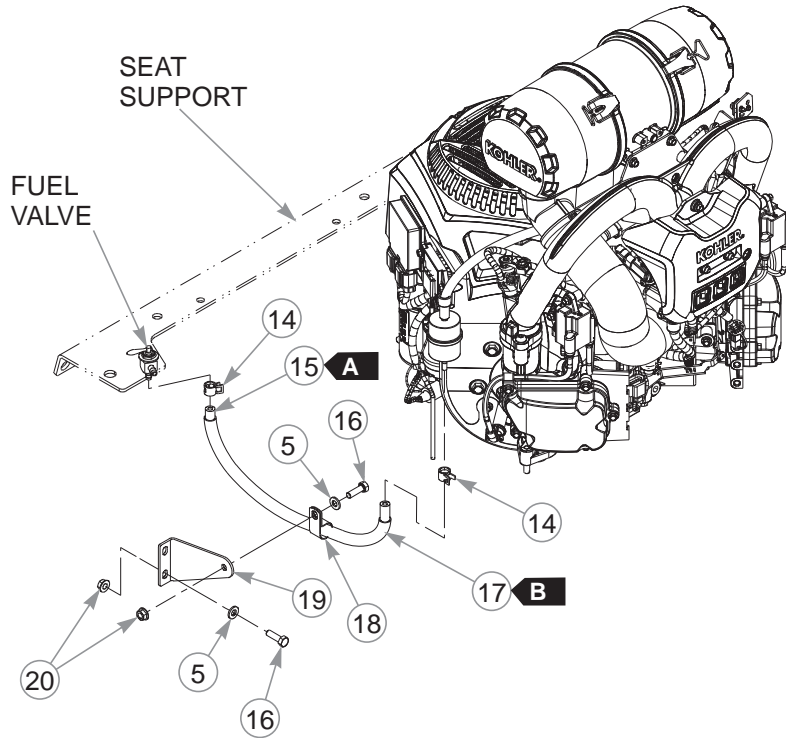

Engine, Kohler

INDEX NO.	PART NO.	QTY.	DESCRIPTION
14	000323	2	HOSE CLAMP
15	015818	17"	1/4" FUEL LINE
16	036236	3	CS .312-18 X 1.00 HX G5
17	605215	15"	FUEL LINE THERMAL SHIELD
18	043570	1	LOOP CLAMP
19	114578	1	BRACE
20	016832	3	NT .312-18 HX FLK ZNYC
21	603326	17"	3/16" VAPOR LINE

NOTES:

FUEL & VAPOR LINE LENGTHS		
A	17"	VALVE TO ENGINE (FUEL)
B	15"	VALVE TO ENGINE (FUEL LINE THERMAL SHIELD)
C	17"	TEE TO ENGINE (VAPOR)

Engine Service Parts, Kohler

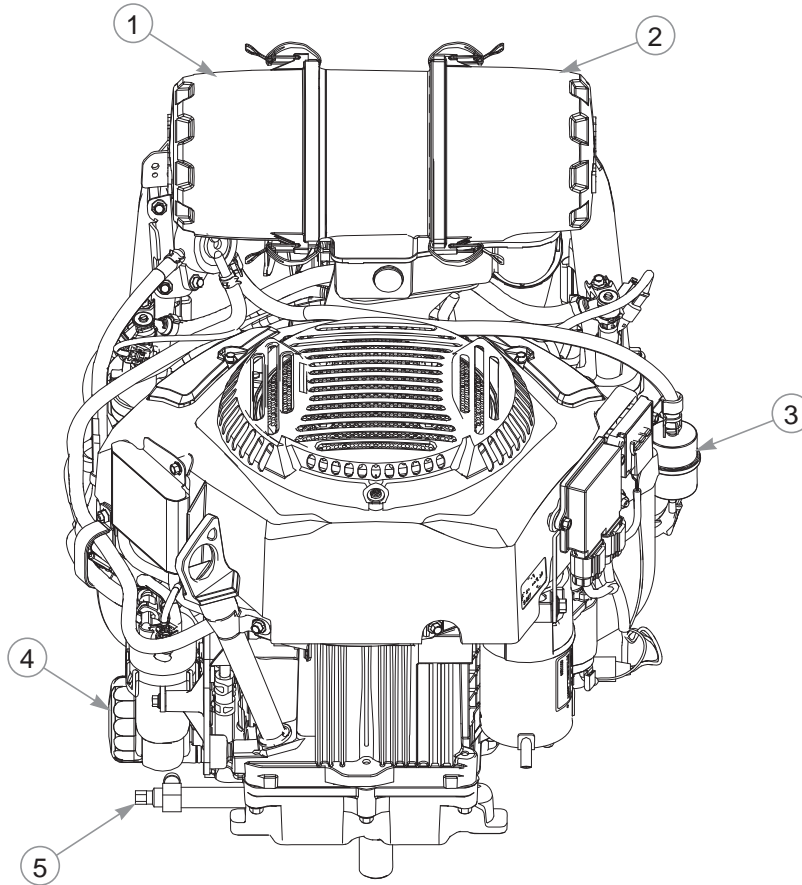

INDEX NO.	PART NO.	QTY.	DESCRIPTION
1	602587	1	MAIN AIR FILTER ELEMENT
2	602586	1	SAFETY AIR FILTER ELEMENT
3	606228	1	FUEL FILTER, KOH ECV
4	704544	1	OIL FILTER
5	796672	1	OIL DRAIN VALVE

NOTES:

This page intentionally left blank.



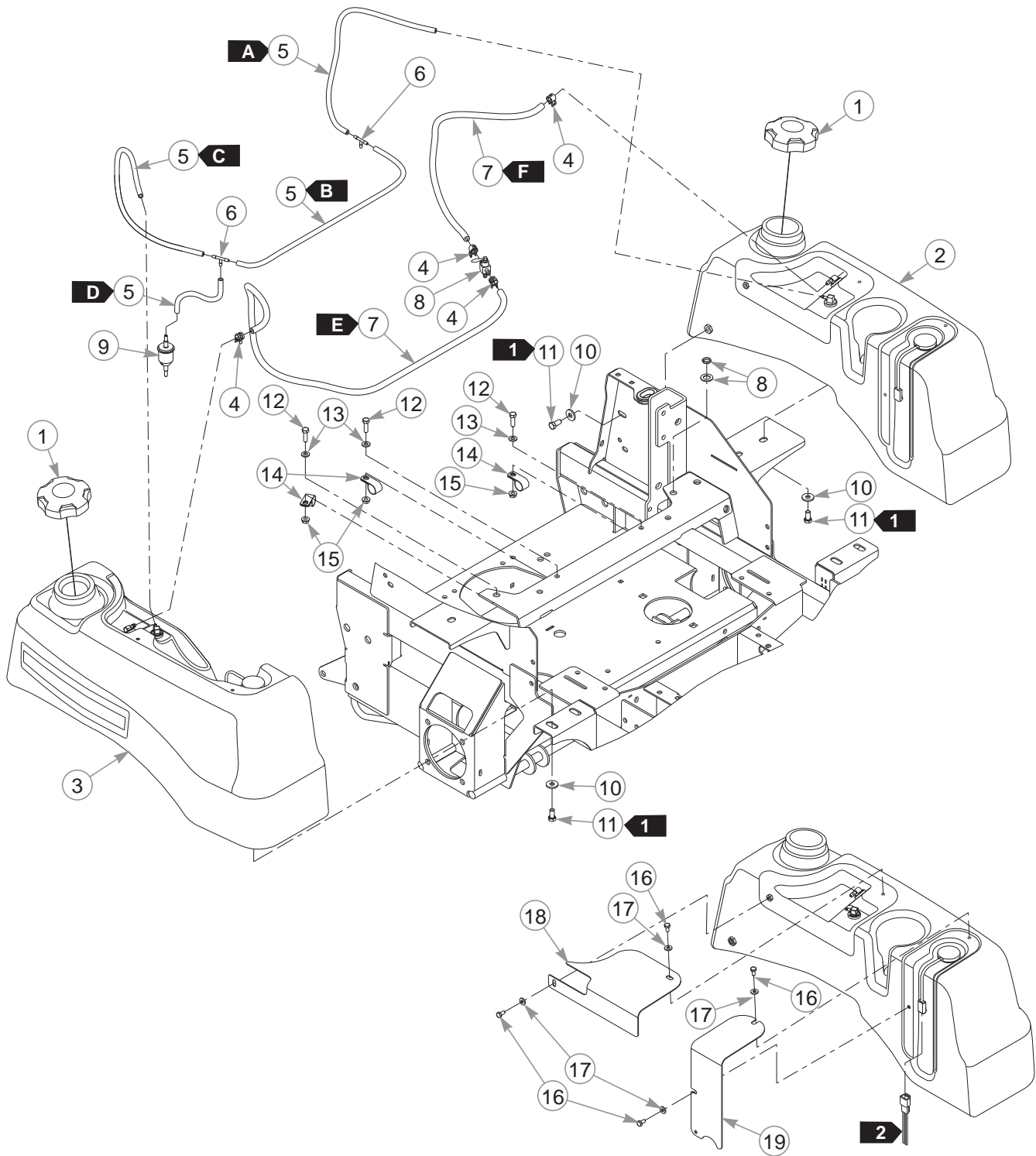



Fuel System, Kawasaki



Fuel System, Kawasaki

INDEX NO.	PART NO.	QTY.	DESCRIPTION
1	603807	2	RATCHETING GAS CAP, 3.5"
2	605102	1	LS FUEL TANK
3	605101	1	RS FUEL TANK
4	000323	4	HOSE CLAMP
5	603326	74"	3/16" VAPOR LINE
6	604281	2	3/16" PLASTIC TEE
7	015818	66"	1/4" FUEL LINE
8	745059	1	FUEL VALVE 3-WAY
9	604323	1	VAPOR SYSTEM FILTER
10	712919	10	FW .406 X 1.00 X .12 HRD Z
11	055822	10	CS .375-16 X .75 HX G5
12	036236	3	CS .312-18 X 1.00 HX G5
13	768523	3	FW .343 X .687 X .051/.080H
14	043570	3	LOOP CLAMP
15	016832	3	NT .312-18 HX FLK
16	055947	4	CS .250-20 X .50 HX G5
17	768515	4	FW .281 X .625 X .066
18	115998	1	TANK COVER
19	115999	1	TANK COVER
20	000331	1	WIRE TIE (NOT SHOWN)

NOTES:

FUEL & VAPOR LINE LENGTHS		
A 	17"	LEFT TANK TO TEE (VAPOR)
B 	24"	TEE TO TEE (VAPOR)
C 	24"	RIGHT TANK TO TEE (VAPOR)
D 	9"	TEE TO FILTER (VAPOR)
E 	44"	RIGHT TANK TO VALVE (FUEL)
F 	22"	LEFT TANK TO VALVE (FUEL)

1. Torque to 16 ft-lbs.
2. Part of the wire harness.

Fuel System, Kohler—Without Carbon Canister

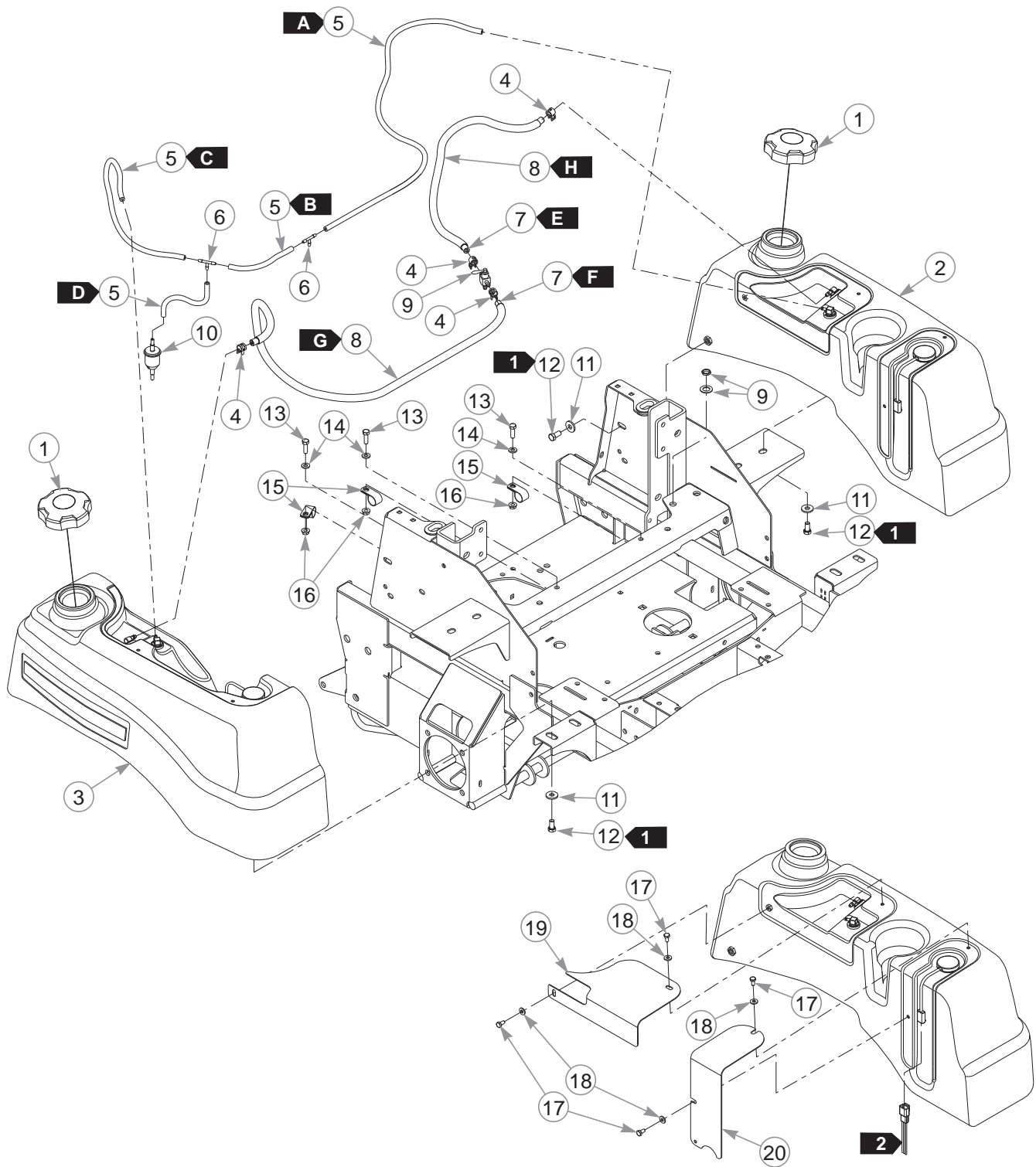

Fuel System, Kohler—Without Carbon Canister

INDEX NO.	PART NO.	QTY.	DESCRIPTION
1	603807	2	RATCHETING GAS CAP, 3.5"
2	605102	1	LS FUEL TANK
3	605101	1	RS FUEL TANK
4	000323	4	HOSE CLAMP
5	603326	77"	3/16" VAPOR LINE
6	604281	2	3/16" PLASTIC TEE
7	015818	66"	1/4" FUEL LINE
8	605215	62"	FUEL LINE THERMAL SHIELD
9	745059	1	FUEL VALVE 3-WAY
10	604323	1	VAPOR SYSTEM FILTER
11	712919	10	FW .406 X 1.00 X .12 HRD Z
12	055822	10	CS .375-16 X .75 HX G5
13	036236	3	CS .312-18 X 1.00 HX G5
14	768523	3	FW .343 X .687 X .051/.080H
15	043570	3	LOOP CLAMP
16	016832	3	NT .312-18 HX FLK
17	055947	4	CS .250-20 X .50 HX G5
18	768515	4	FW .281 X .625 X .066
19	115998	1	TANK COVER
20	115999	1	TANK COVER
21	000331	1	WIRE TIE (NOT SHOWN)

NOTES:

FUEL & VAPOR LINE LENGTHS		
A →	37"	LEFT TANK TO TEE (VAPOR)
B →	7"	TEE TO TEE (VAPOR)
C →	24"	RIGHT TANK TO TEE (VAPOR)
D →	9"	TEE TO FILTER (VAPOR)
E →	22"	LEFT TANK TO VALVE (FUEL)
F →	44"	RIGHT TANK TO VALVE (FUEL)
G →	42"	FUEL LINE THERMAL SHIELD
H →	20"	FUEL LINE THERMAL SHIELD

1. Torque to 16 ft-lbs.
2. Part of the wire harness.

Fuel System, Kohler—With Carbon Canister

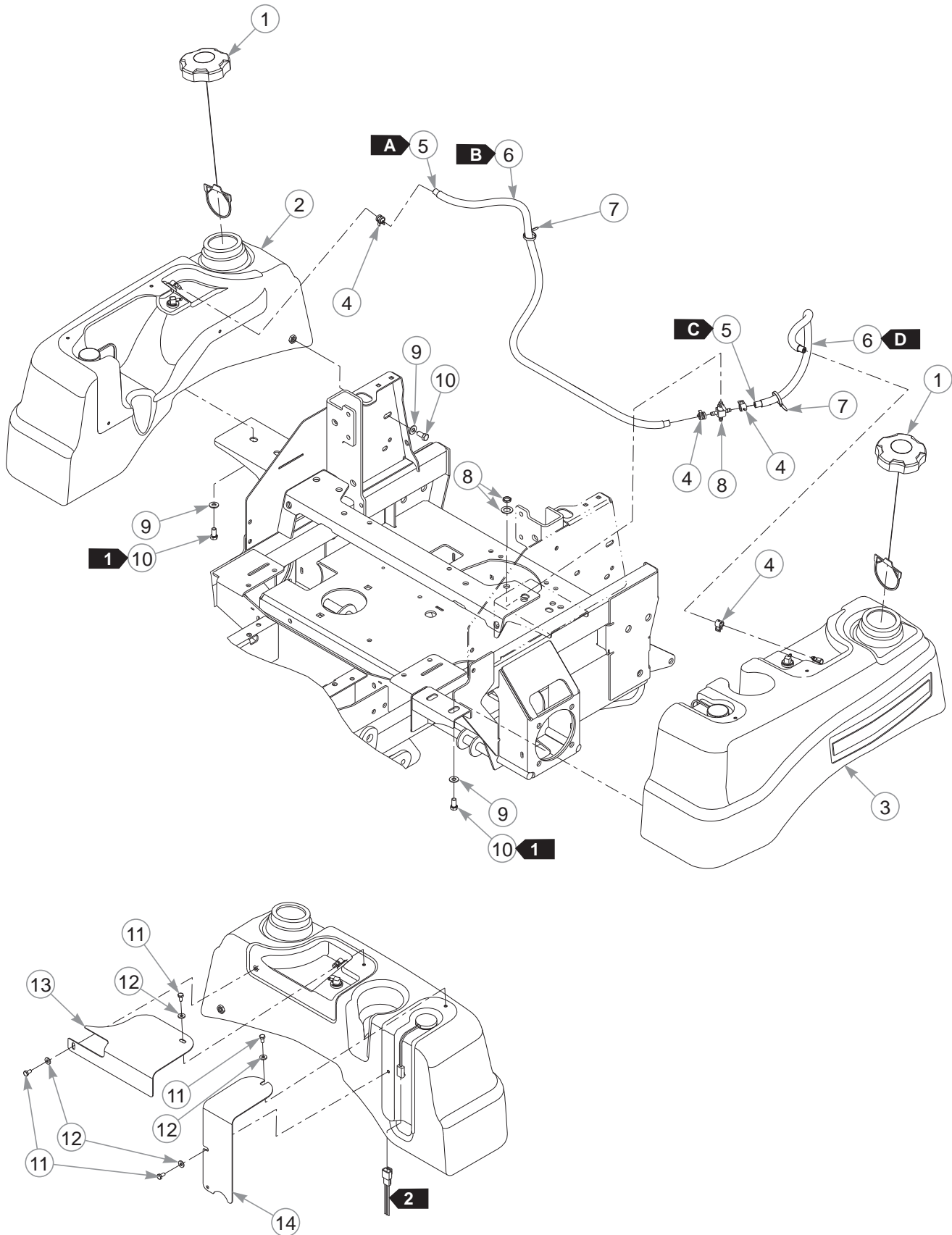

Fuel System, Kohler—With Carbon Canister

INDEX NO.	PART NO.	QTY.	DESCRIPTION
1	603807	2	RATCHETING GAS CAP, 3.5"
2	605101	1	RS FUEL TANK
3	605102	1	LS FUEL TANK
4	000323	4	HOSE CLAMP
5	015818	66"	1/4" FUEL LINE
6	605215	62"	FUEL LINE THERMAL SHIELD
7	000331	3	WIRE TIE
8	745059	1	FUEL VALVE 3-WAY
9	767954	10	FW .379 X .813 X .063
10	055822	10	CS .375-16 X .75 HX G5
11	055947	4	CS .250-20 X .50 HX G5
12	768515	4	FW .281 X .625 X .066
13	115998	1	TANK COVER
14	115999	1	TANK COVER

NOTES:

FUEL LINE LENGTHS		
A	44"	RIGHT TANK TO VALVE (FUEL)
B	42"	RIGHT TANK TO VALVE (THERMAL SHIELD)
C	22"	LEFT TANK TO VALVE (FUEL)
D	20"	LEFT TANK TO VALVE (THERMAL SHIELD)

1. Torque to 16 ft-lbs.
2. Part of the wire harness.

Vapor System, Kohler—With Carbon Canister

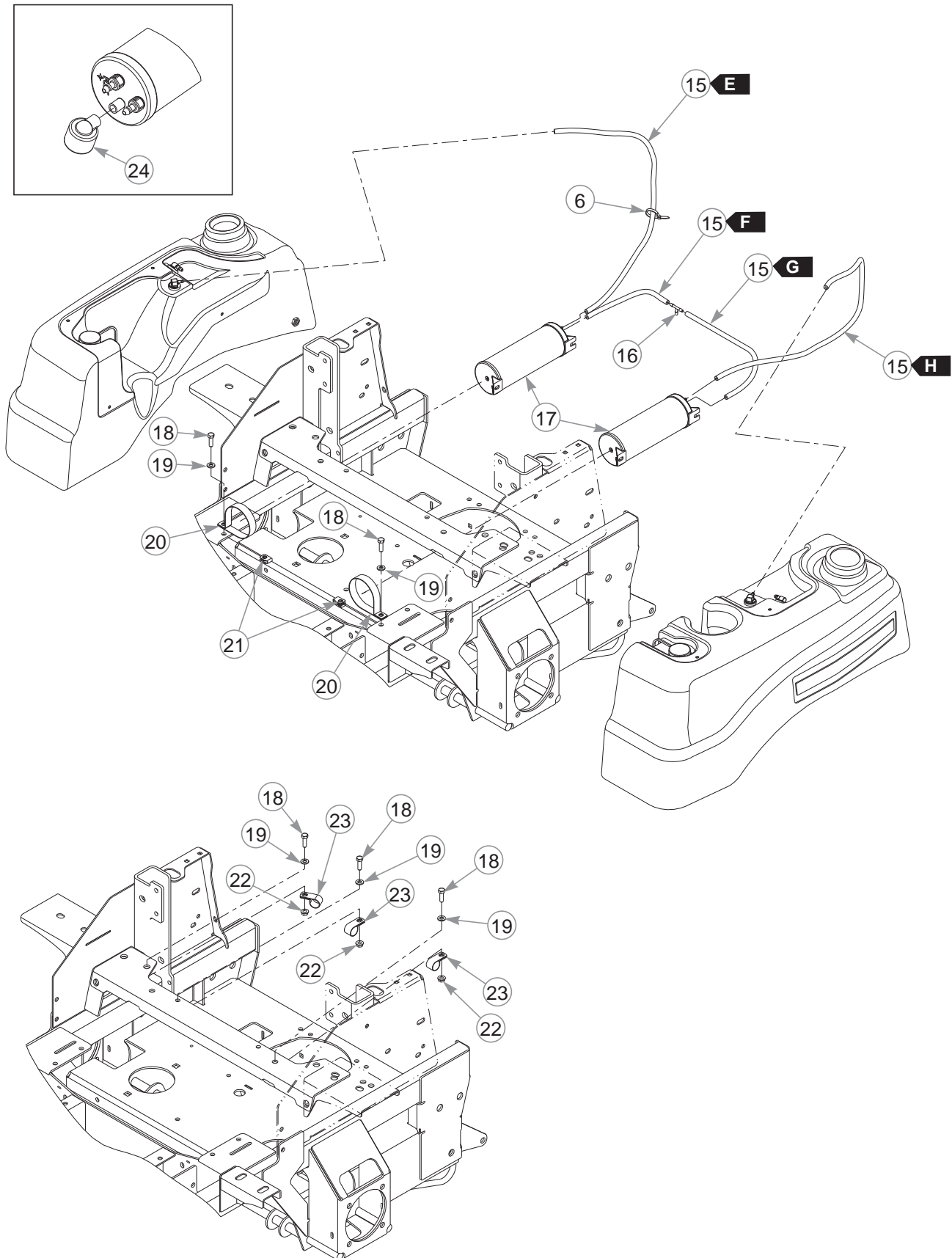

Vapor System, Kohler—With Carbon Canister

INDEX NO.	PART NO.	QTY.	DESCRIPTION
15	603326	83"	3/16" VAPOR LINE
16	604281	1	3/16" PLASTIC TEE
17	604314	2	CARBON CANISTER
18	036236	7	CS .312-18 X 1.00 HX G5
19	768523	7	FW .343 X .687 X .051/.080H
20	602980	4	3.0" CUSHIONED CLAMP
21	601069	4	CN .312-18 X .20 MAX THK
22	016832	3	NT .312-18 HX FLK
23	043570	3	LOOP CLAMP
24	603161	1	VACUUM BREAKER FILTER

NOTES:

VAPOR LINE LENGTHS		
E	30"	RIGHT TANK TO RIGHT CARBON CANISTER (VAPOR)
F	9"	RIGHT CARBON CANISTER TO TEE (VAPOR)
G	14"	LEFT CARBON CANISTER TO TEE (VAPOR)
H	30"	LEFT TANK TO LEFT CARBON CANISTER (VAPOR)

Fuel Tank Service Parts

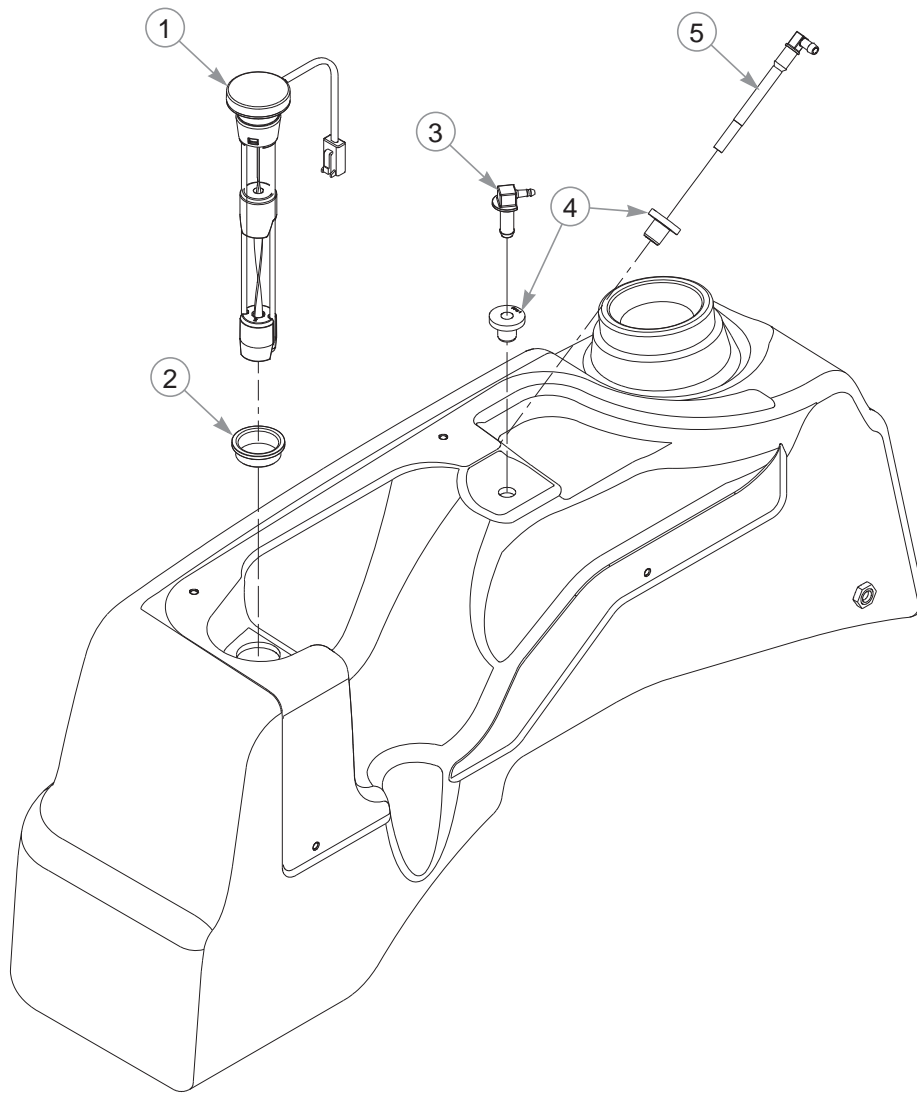

INDEX NO.	PART NO.	QTY.	DESCRIPTION
1	603888	1	FUEL SENDER
2	605648	1	GROMMET
3	604287	1	VENT FITTING
4	604200	2	GROMMET
5	605158	1	SUCTION HOSE ASSEMBLY

NOTES:

Section 6

Battery	6-2
Instrument Panel, Kawasaki	6-4
Instrument Panel, Kohler	6-6

Battery

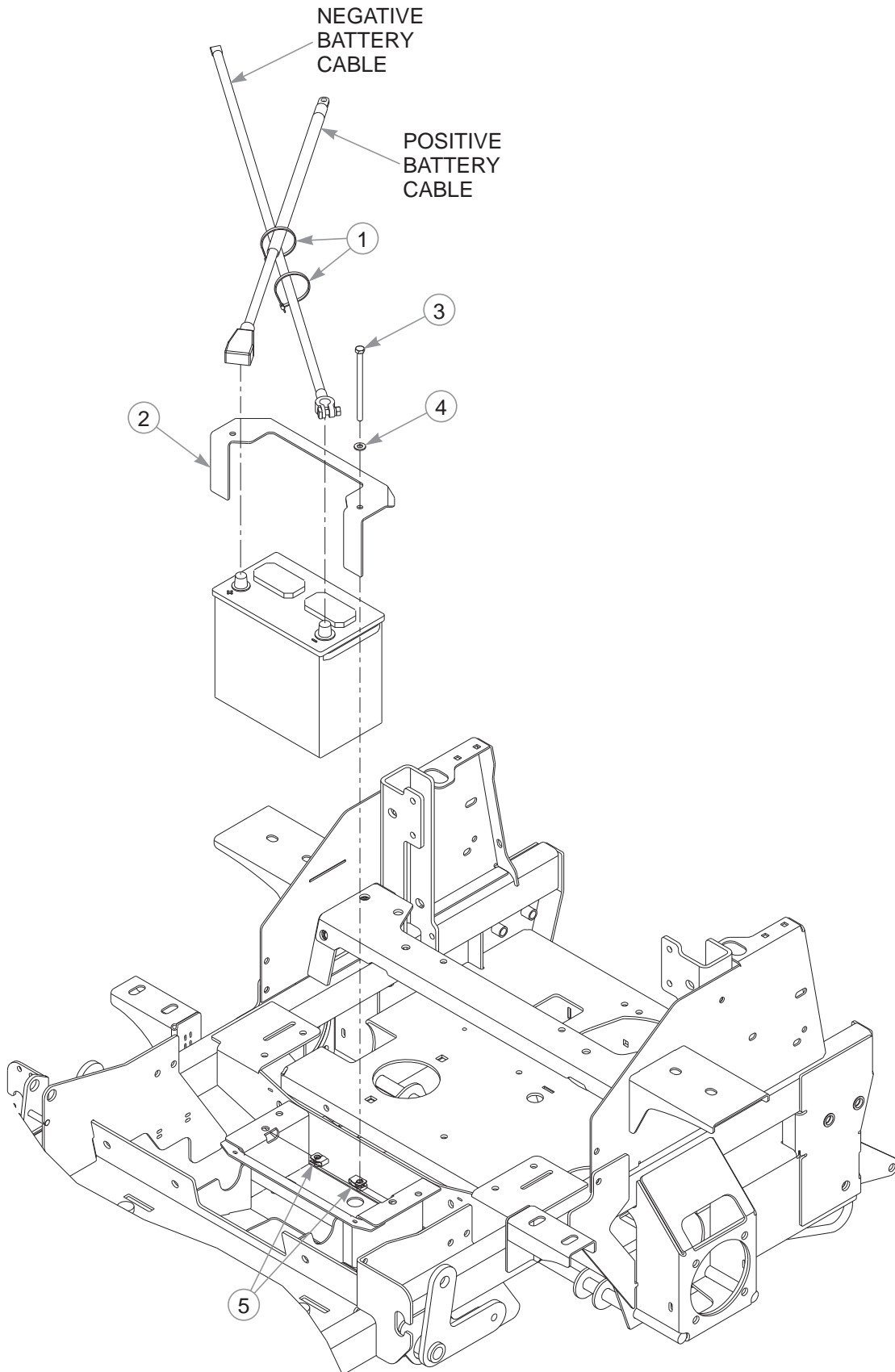

Battery

INDEX NO.	PART NO.	QTY.	DESCRIPTION
1	000331	3	WIRE TIE
2	113676	1	BATTERY STRAP
3	050823	2	CS .312-18 X 5.00 HX G5
4	768523	2	FW .343 X .687 X .051/.080H
5	601069	2	CN .312-18 X .20 MAX THK

NOTES:

Instrument Panel, Kawasaki

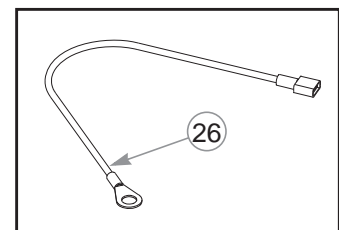
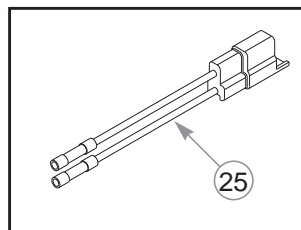
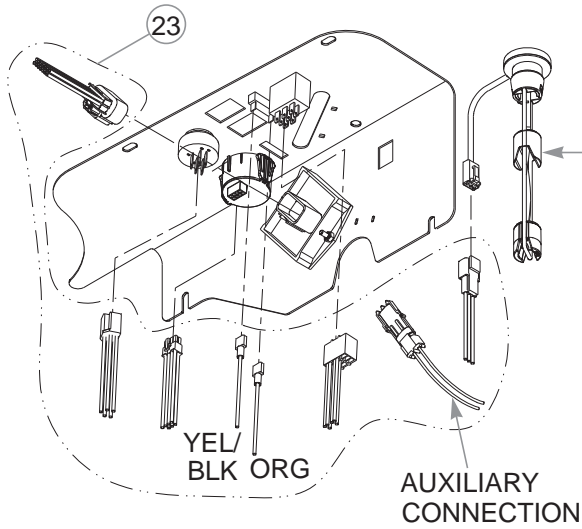
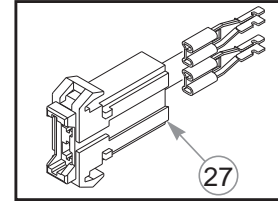
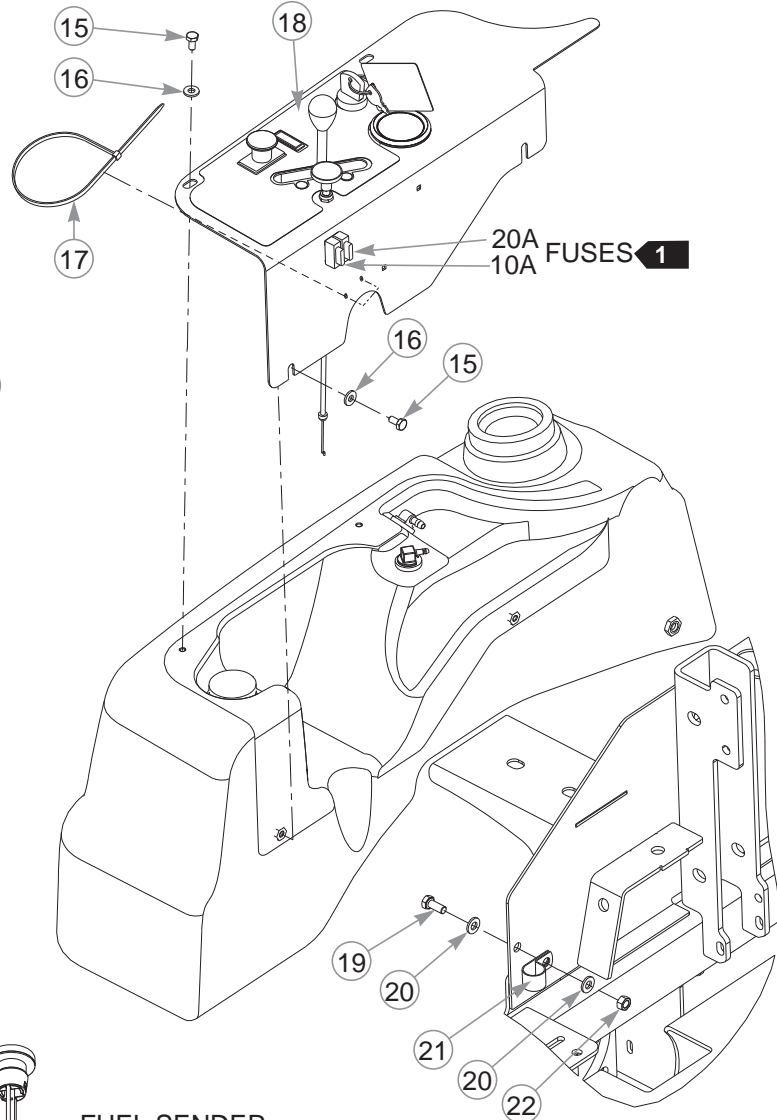
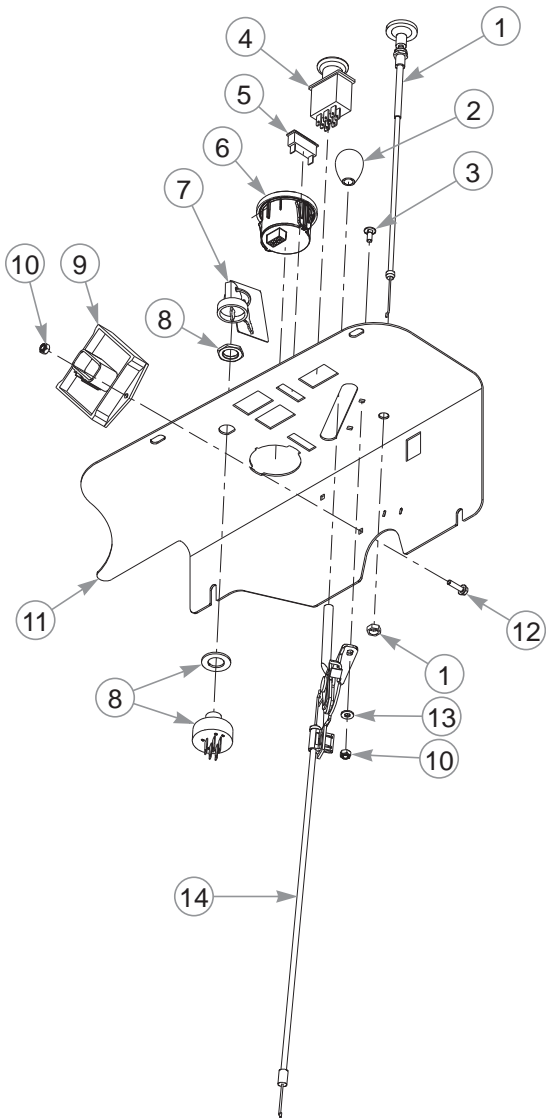

Instrument Panel, Kawasaki

INDEX NO.	PART NO.	QTY.	DESCRIPTION
1	601095	1	CHOKE CABLE
2	603523	1	KNOB
3	601098	2	CB 10-24 X .500 ZYNC
4	776476	1	PTO SWITCH
5	712257	1	RED INDICATOR LIGHT
6	606068	1	FUEL DISPLAY/HOUR METER
7	785808	1	KEY ASSEMBLY
8	045898	1	IGNITION SWITCH
9	604373	1	RELAY CONTROL MODULE
10	059832	4	NT #10-24 HX NL ZN
11	553453	1	INSTRUMENT PANEL (WITH DECAL)
12	063198	2	CS 10-24 X .75 HX FLK ZN
13	704932	2	FW .219 X .500 X .048
14	603847	1	THROTTLE CABLE 50" (FX850V)
	603409	1	THROTTLE CABLE 60" (FX1000V)
15	055947	4	CS .250-20 X .50 HX G5
16	768515	4	FW .281 X .625 X .066
17	000430	1	WIRE TIE
18	606075	1	INSTRUMENT PANEL DECAL
19	034280	1	CS .312-18 X .75 HX G5
20	768523	2	FW .343 X .687 X .051/.080H
21	043570	1	LOOP CLAMP
22	034272	1	NT .312-18 HX G5
23	604241	1	WIRE HARNESS
24	000331	8	WIRE TIE (NOT SHOWN)
25	114052	1	CLUTCH CONNECTOR REPAIR KIT
26	604430	1	WIRE HARNESS
27	601047	1	FUSE HOLDER

NOTES:

1. Part of the wire harness.

Instrument Panel, Kohler

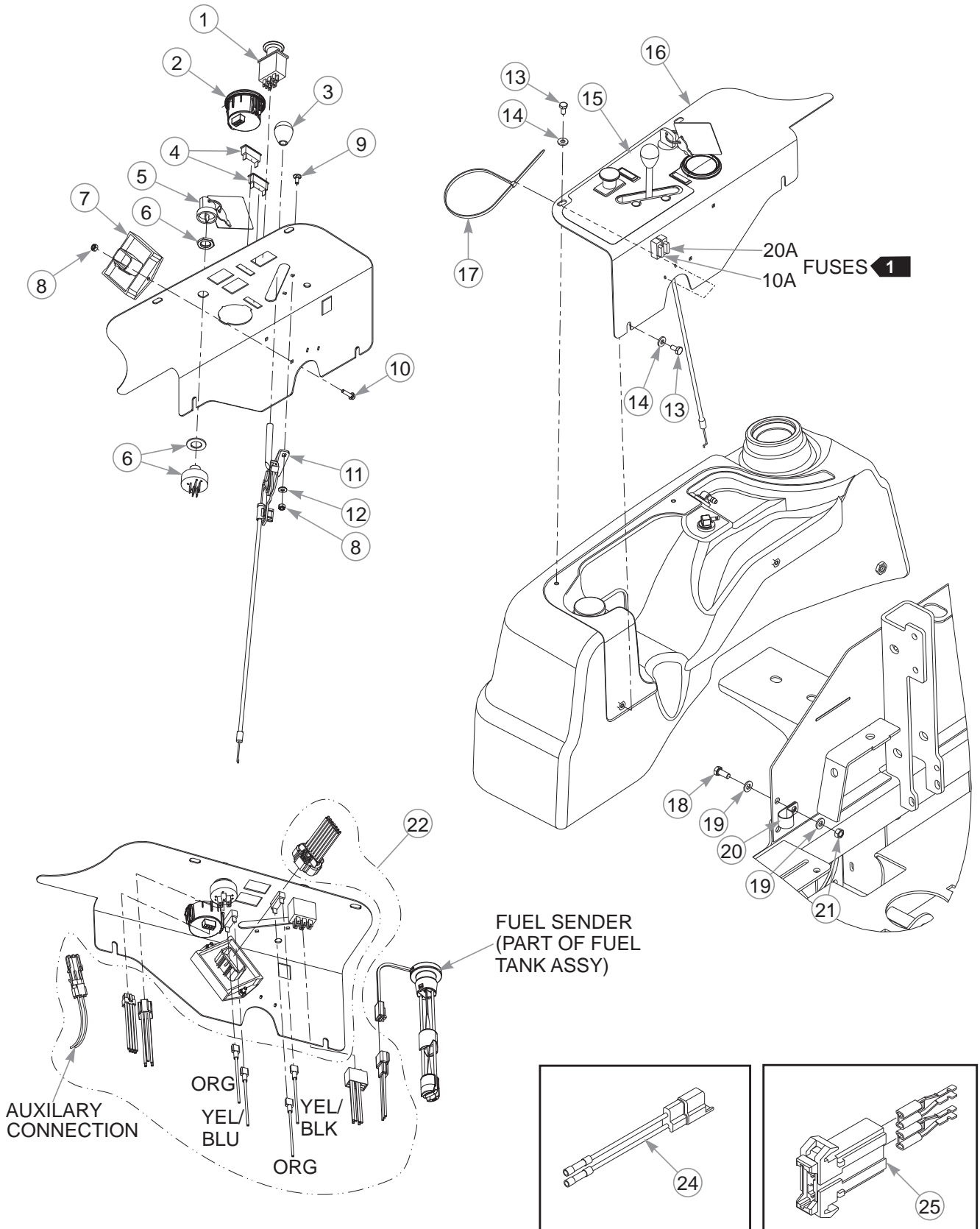

Instrument Panel, Kohler

INDEX NO.	PART NO.	QTY.	DESCRIPTION
1	776476	1	PTO SWITCH
2	606068	1	FUEL DISPLAY/HOUR METER
3	603523	1	KNOB
4	712257	2	RED INDICATOR LIGHT
5	785808	1	KEY ASSEMBLY
6	045898	1	IGNITION SWITCH
7	604373	1	RELAY CONTROL MODULE
8	059832	4	NT #10-24 HX NL ZN
9	601098	2	CB 10-24 X .500 ZYNC
10	063198	2	CS 10-24 X .75 HX FLK ZN
11	603847	1	THROTTLE CABLE 50"
12	704932	2	FW .219 X .500 X .048 ZNYC
13	055947	4	CS .250-20 X .50 HX G5
14	768515	4	FW .281 X .625 X .066
15	606156	1	INSTRUMENT PANEL DECAL
16	553454	1	INSTRUMENT PANEL (WITH DECAL)
17	000430	1	WIRE TIE
18	034280	1	CS .312-18 X .75 HX G5
19	768523	2	FW .343 X .687 X .051/.080H
20	043570	1	LOOP CLAMP
21	034272	1	NT .312-18 HX G5
22	606165	1	WIRE HARNESS
23	000331	8	WIRE TIE (NOT SHOWN)
24	114052	1	CLUTCH CONNECTOR REPAIR KIT
25	601047	1	FUSE HOLDER

NOTES:

1. Part of the wire harness.

Section 7

54" Service Deck	7-2
54" Deck Pulleys & Spindles	7-4
54" Deck	7-6
60" Side Discharge Service Deck	7-8
60" Side Discharge Deck Pulleys & Spindles	7-10
60" Side Discharge Deck	7-12
66" Service Deck	7-14
66" Deck Pulleys & Spindles	7-16
66" Deck	7-18
72" Side Discharge Service Deck	7-20
72" Side Discharge Deck Pulleys & Spindles	7-22
72" Side Discharge Deck	7-24
60" Rear Discharge Service Deck	7-26
60" Rear Discharge Deck Pulleys & Spindles	7-28
60" Rear Discharge Dust Shield	7-32
60" Rear Discharge Deck	7-34
72" Rear Discharge Service Deck	7-38
72" Rear Discharge Deck Pulleys & Spindles	7-40
72" Rear Discharge Dust Shield	7-44
72" Rear Discharge Deck	7-46
Deck Lift	7-50
Deck Mounting Hardware	7-52

54" Service Deck

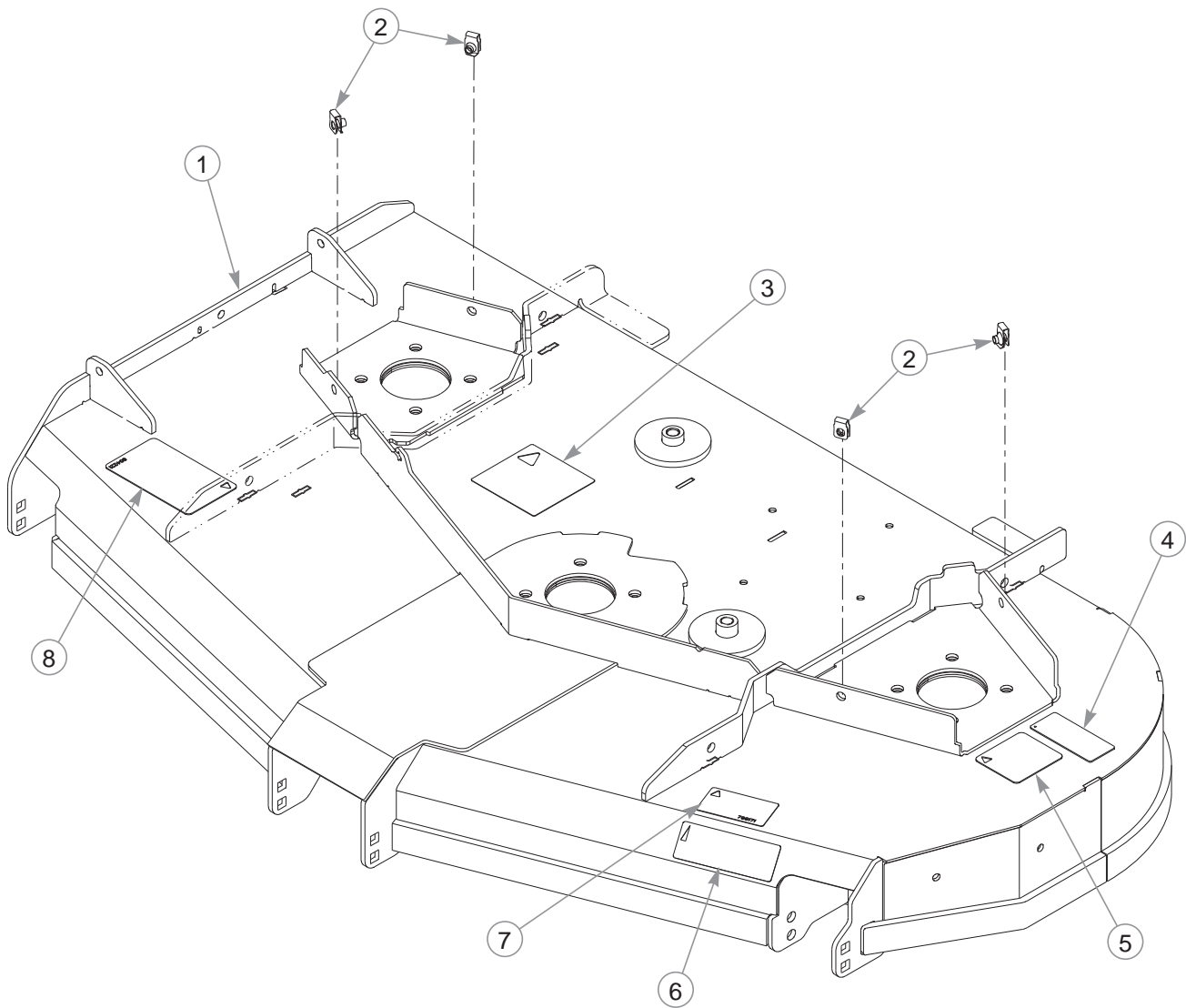

54" Service Deck

INDEX NO.	PART NO.	QTY.	DESCRIPTION
1	553085	1	54" DECK (WITH DECALS)
2	601069	4	CN .312-18 X .20 MAX THK
3	781419	1	BELT ROUTING DECAL
4	601892	1	THROWN OBJECTS DECAL
5	601837	1	DECK DANGERS DECAL
6	603092	1	VX4 TECHNOLOGY DECAL
7	799171	1	54" DECK ID DECAL
8	604221	1	DANGER/CHUTE DECAL

NOTES:

54" Deck Pulleys & Spindles

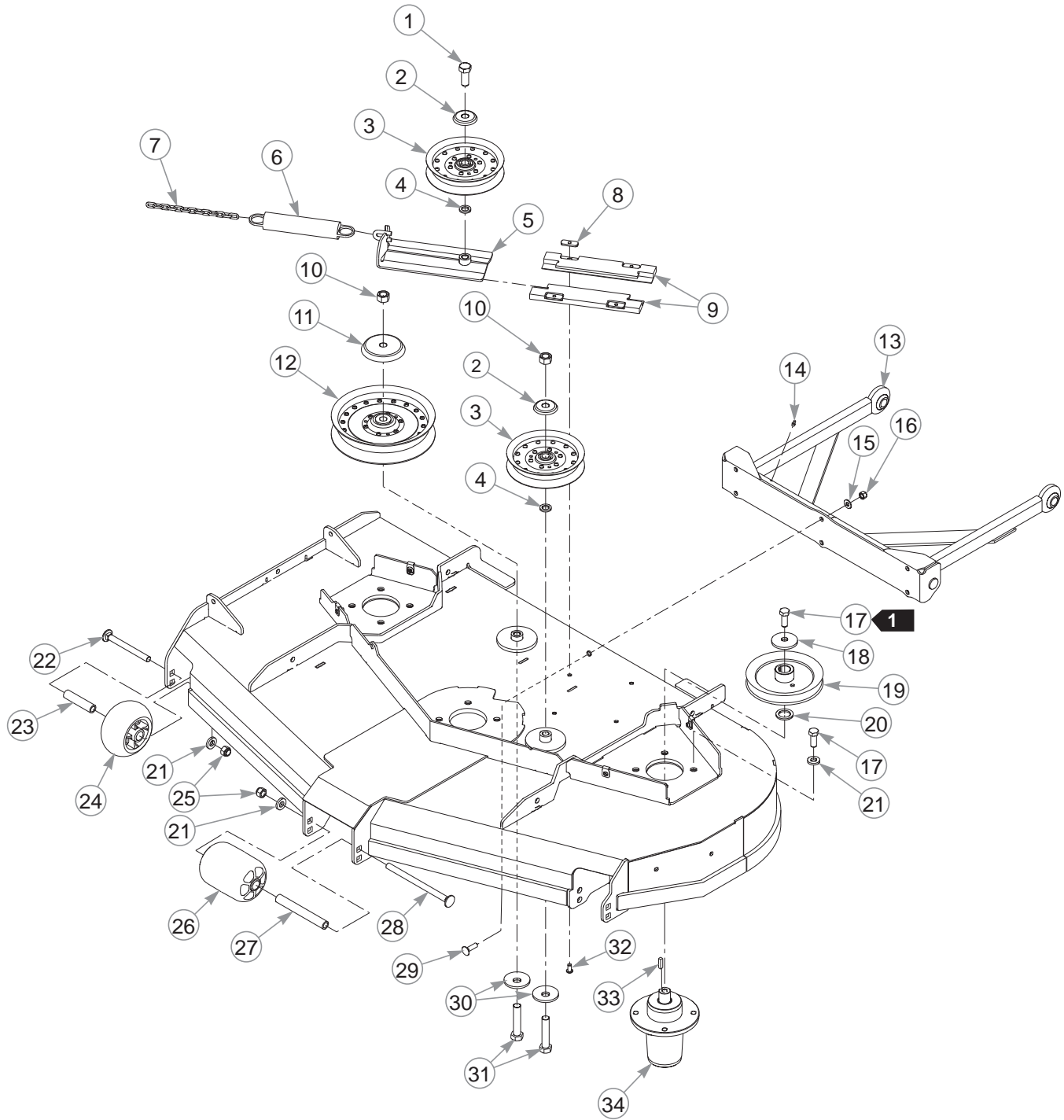

54" Deck Pulleys & Spindles

INDEX NO.	PART NO.	QTY.	DESCRIPTION
1	794446	1	CS .625-11 X 1.50 HX G5
2	602935	2	IDLER DUST SHIELD SM
3	602821	2	IDLER 6.0" RIVETED
4	028118	2	FW .625 X 1.00 X .134
5	350884	1	DECK IDLER SLIDE
6	781302	1	TENSION SPRING
7	259812	1	CHAIN, 13 LINK
8	603023	4	WN .312-18 ZN
9	602936	2	UHMW IDLER SLIDE
10	016972	2	NT .625-11 HX G5 ZNYC
11	602963	1	IDLER DUST SHIELD LG
12	602838	1	IDLER 8.0" RIVETED
13	113340	1	PUSHER
14	015495	2	GREASE FITTING STRAIGHT
15	767954	6	FW .379 X .813 X .063
16	086660	6	NT .375-16 HX G5 NL
17	705954	15	CS .500-13 X 1.25 HX G5
18	752386	3	CW .515 X 2.25 X .204 BLK
19	798975	3	PULLEY
20	045765	3	FW 1.030 X 1.50 X .134
21	767962	15	FW .531 X 1.063 X .175
22	603049	2	CB .500-13 X 5.00 ZNYC
23	602345	2	SPACER 3.22
24	602263	2	PLASTIC WHEEL
25	781567	3	NT .500-13 HX G8 ZY NL
26	602341	1	PLASTIC WHEEL
27	602344	1	SPACER 5.73
28	602338	1	CB .500-13 X 7.50 STD ZN
29	603113	6	CB .375-16 X 1.25 G5 ZN
30	782474	2	CW .631 X 2.25 X .187 PNT
31	783738	2	CS .625-11 X 3.00 FULL HX G5
32	603022	4	CS .312-18 X .625 BH ZN
33	212472	3	KEY 1/4 SQ X 1.00
34	604255	3	BLADE SPINDLE CW

NOTES:

1. Torque to 67–75 ft-lbs.

54" Deck

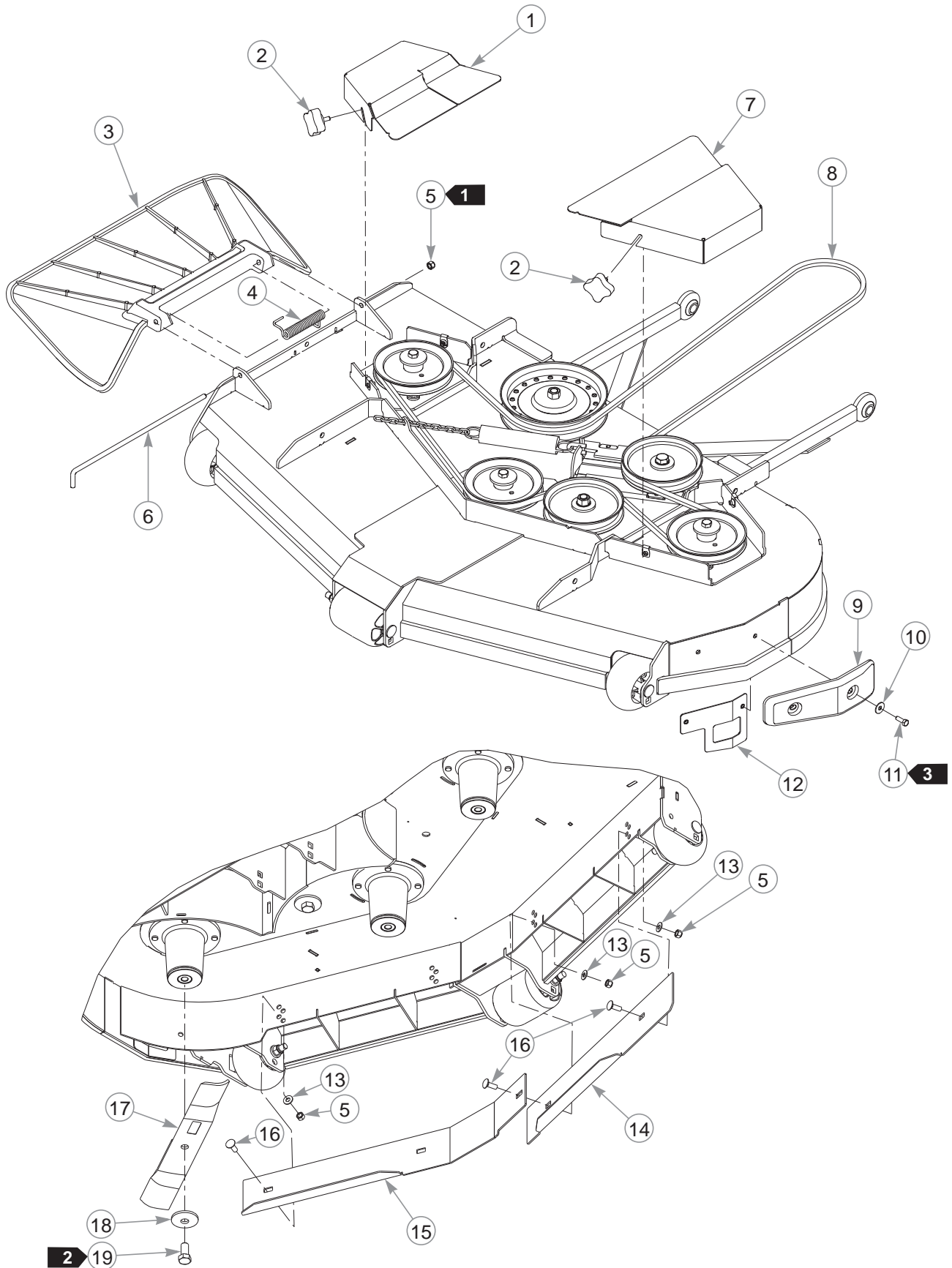

54" Deck

INDEX NO.	PART NO.	QTY.	DESCRIPTION
1	121895	1	PULLEY COVER RS
2	792002	4	KNOB 5/16-18 X 3/4"
3	602429	1	DISCHARGE CHUTE
4	602435	1	TORSION SPRING
5	086660	5	NT .375-16 HX G5 ZY NL
6	602432	1	CHUTE PIN
7	121894	1	PULLEY COVER LS
8	601715	1	BELT, B 162.0" EL
9	602817	1	RUBBER BUMPER
10	079210	2	FW .344 X 1.00 X .06 ZNYC
11	064014	2	CS .312-18 X .875 HX G5
12	113563	1	BACKING PLATE
13	767954	4	FW .379 X .813 X .063
14	113211	1	RS ADJ INNER WALL
15	113210	1	LS ADJ INNER WALL
16	025395	4	CB .375-16 X 1.00 G5 ZNY
17	797696	3	BLADE, F18.50"-H-F-CW
	601014	3	BLADE, F16.50"-L-F-CW
	601123	3	BLADE, 16.50"-L-F-CW
	796623	3	BLADE, 16.50"-MUL-F-CW
	796631	3	BLADE, 16.50"-GAT-F-CW
18	782474	3	CW .631 X 2.25 X .187 PNT
19	781872	3	CS .625-11 X 1.25 HX G5 Z

NOTES:

1. Do not torque; the discharge chute must pivot freely.
2. Torque to 118 ft-lbs.
3. Torque to 10 ft-lbs.

60" Side Discharge Service Deck

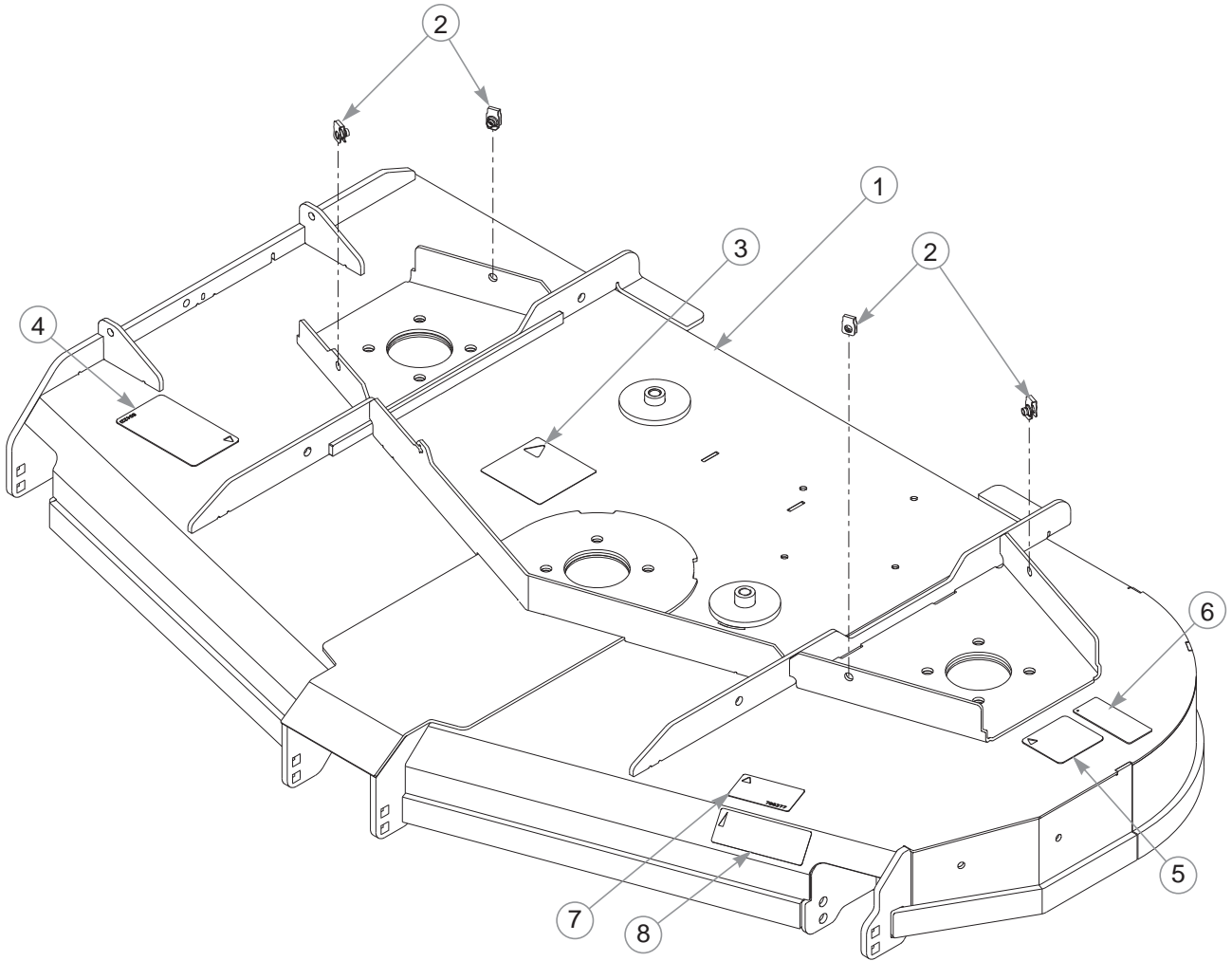

60" Side Discharge Service Deck

INDEX NO.	PART NO.	QTY.	DESCRIPTION
1	550739	1	60" VX4 DECK (WITH DECALS & HARDWARE)
2	601069	4	CN .312-18 X .20 MAX THK
3	781419	1	BELT ROUTING DECAL
4	604221	1	DANGER/CHUTE DECAL
5	601837	1	DECK DANGERS DECAL
6	601892	1	THROWN OBJECTS DECAL
7	786277	1	60" SD DECK ID DECAL
8	603092	1	VX4 TECHNOLOGY DECAL

NOTES:

60" Side Discharge Deck Pulleys & Spindles

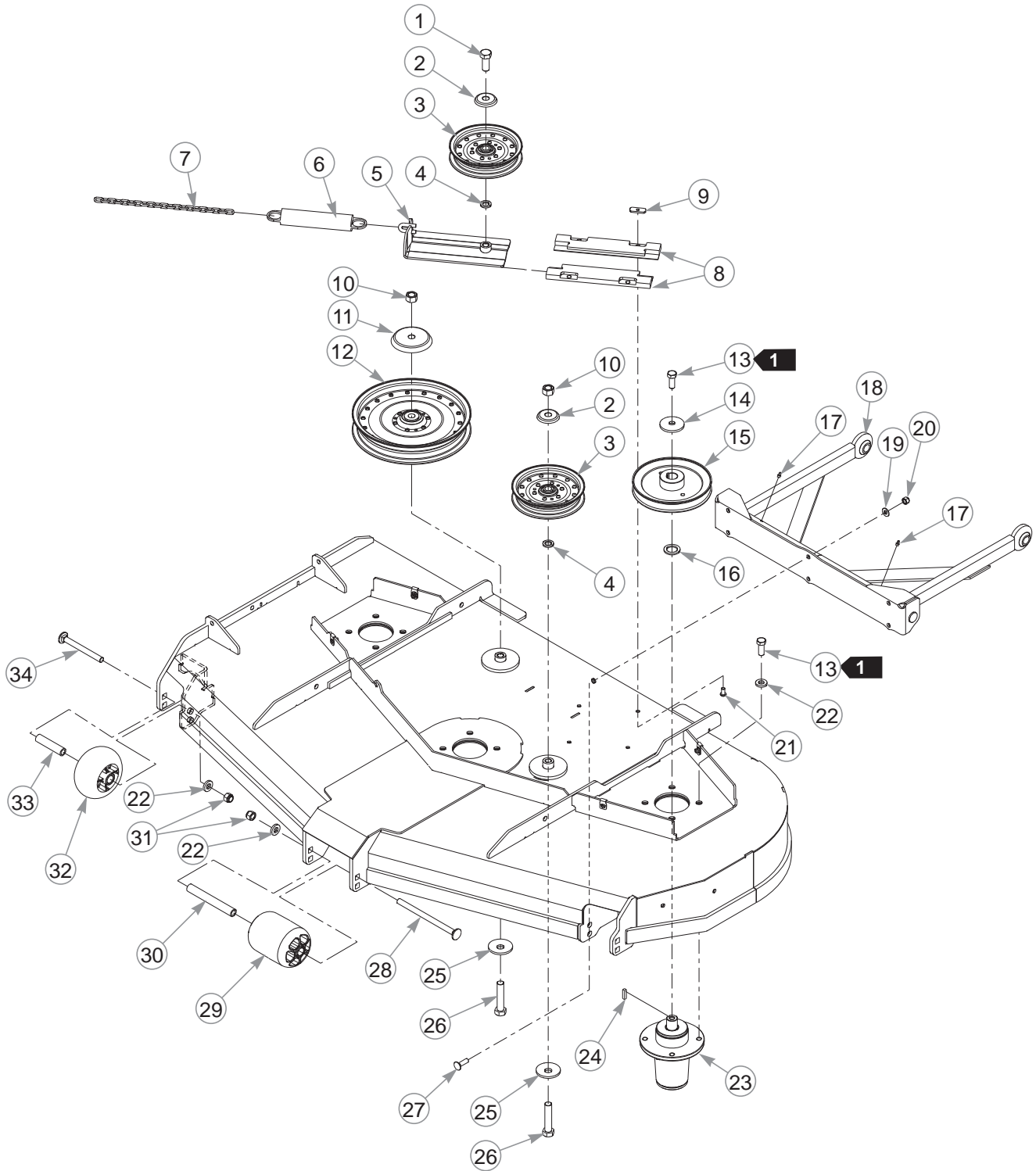

60" Side Discharge Deck Pulleys & Spindles

INDEX NO.	PART NO.	QTY.	DESCRIPTION
1	794446	1	CS .625-11 X 1.50 HX G5
2	602935	2	IDLER DUST SHIELD SM
3	602821	2	IDLER 6.0" RIVETED
4	028118	2	FW .625 X 1.00 X .134
5	350884	1	DECK IDLER SLIDE
6	781302	1	TENSION SPRING
7	373191	1	CHAIN, 21 LINK
8	602936	2	UHMW IDLER SLIDE
9	603023	4	WN .312-18 ZN
10	016972	2	NT .625-11 HX G5 ZNYC
11	602963	1	IDLER DUST SHIELD LG
12	602743	1	IDLER 10.0" RIVETED
13	705954	15	CS .500-13 X 1.25 HX G5
14	752386	3	CW .515 X 2.25 X .204 BLK
15	602745	3	PULLEY DRIVE 7.00 EFF
16	045765	3	FW 1.030 X 1.50 X .134
17	015495	2	GREASE FITTING STRAIGHT
18	113340	1	PUSHER
19	767954	6	FW .379 X .813 X .063
20	086660	6	NT .375-16 HX G5 ZY NL
21	603022	4	CS .312-18 X .625 BH ZN
22	767962	15	FW .531 X 1.063 X .175
23	604255	3	BLADE SPINDLE CW
24	212472	3	KEY 1/4 SQ X 1.00
25	782474	2	CW .631 X 2.25 X .187 PNT
26	783738	2	CS .625-11 X 3.00 FULL HX G5
27	603113	6	CB .375-16 X 1.25 G5 ZN
28	602338	1	CB .500-13 X 7.50 STD ZN
29	602341	1	PLASTIC WHEEL
30	602344	1	SPACER 5.73
31	781567	3	NT .500-13 HX G8 ZY NL
32	602263	2	PLASTIC WHEEL
33	602345	2	SPACER 3.22
34	603049	2	CB .500-13 X 5.00 ZNYC

NOTES:

1. Torque to 67–75 ft-lbs.

60" Side Discharge Deck

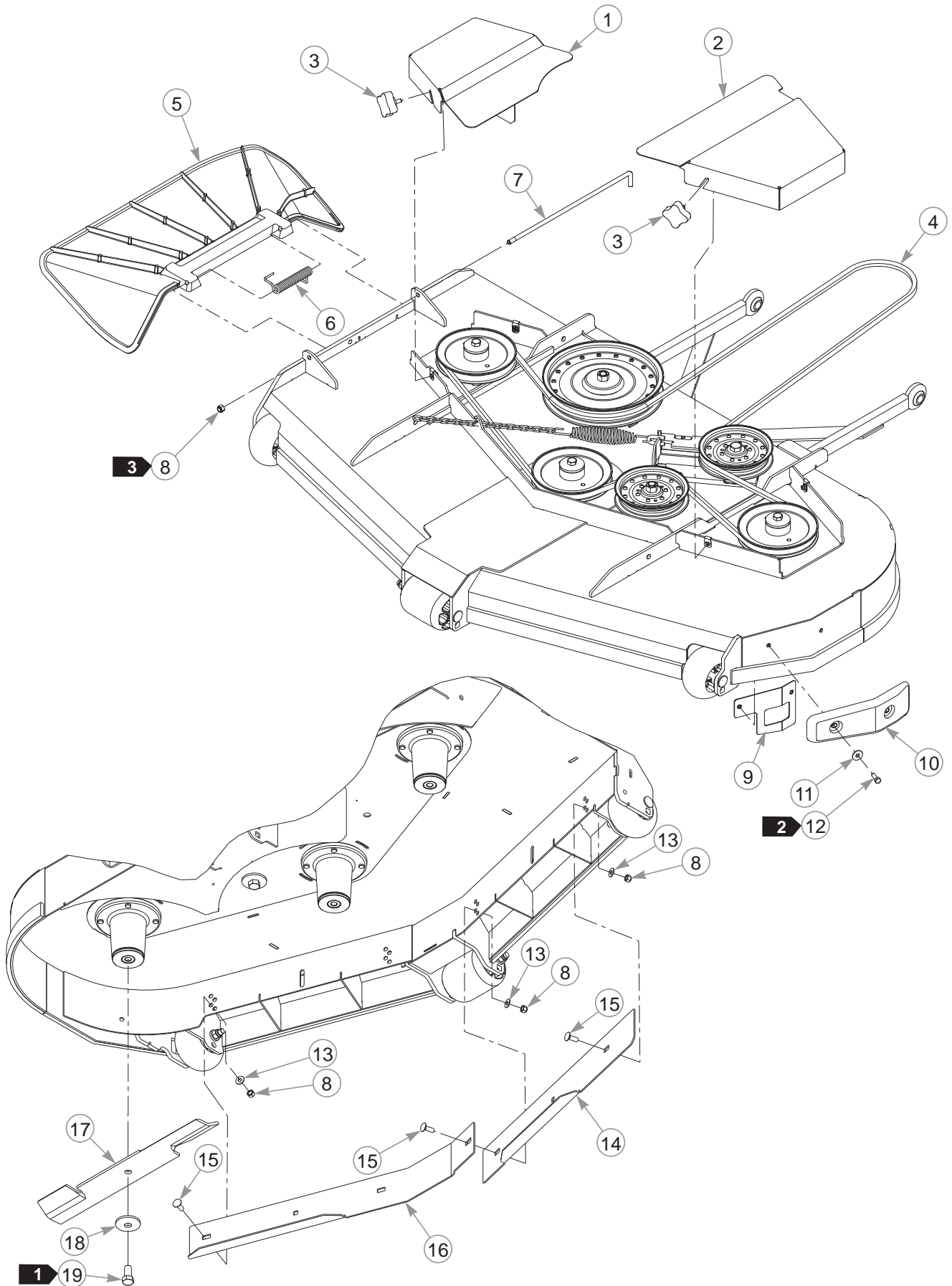

60" Side Discharge Deck

INDEX NO.	PART NO.	QTY.	DESCRIPTION
1	112933	1	RS PULLEY COVER
2	112934	1	LS PULLEY COVER
3	792002	4	KNOB 5/16-18 X 3/4"
4	604494	1	BELT, B-SEC 172" EL
5	602891	1	DISCHARGE CHUTE LG
6	602435	1	TORSION SPRING
7	602432	1	CHUTE PIN
8	086660	7	NT .375-16 HX G5 ZY NL
9	113563	1	BACKING PLATE
10	602817	1	RUBBER BUMPER
11	079210	2	FW .344 X 1.00 X .06 ZNYC
12	064014	2	CS .312-18 X .875 HX G5 ZN
13	767954	6	FW .379 X .813 X .063
14	113180	1	RS INNER WALL ADJ.
15	025395	6	CB .375-16 X 1.00 G5 ZNY
16	113179	1	LS INNER WALL ADJ.
17	602771	3	BLADE, F20.50" EHN-F-CW
	793794	3	BLADE, 20.50"-L-F-CW
	794214	3	BLADE, 20.50"-MUL-F-CW
	794230	3	BLADE, 20.50" -GAT-F-CW
	794685	3	BLADE, F20.50"-H-F-CW
18	782474	3	CW .631 X 2.25 X .187 PNT
19	781872	3	CS .625-11 X 1.25 HX G5 Z

NOTES:

1. Torque to 118 ft-lbs.
2. Torque to 10 ft-lbs.
3. Do not torque; the discharge chute must pivot freely.

66" Service Deck

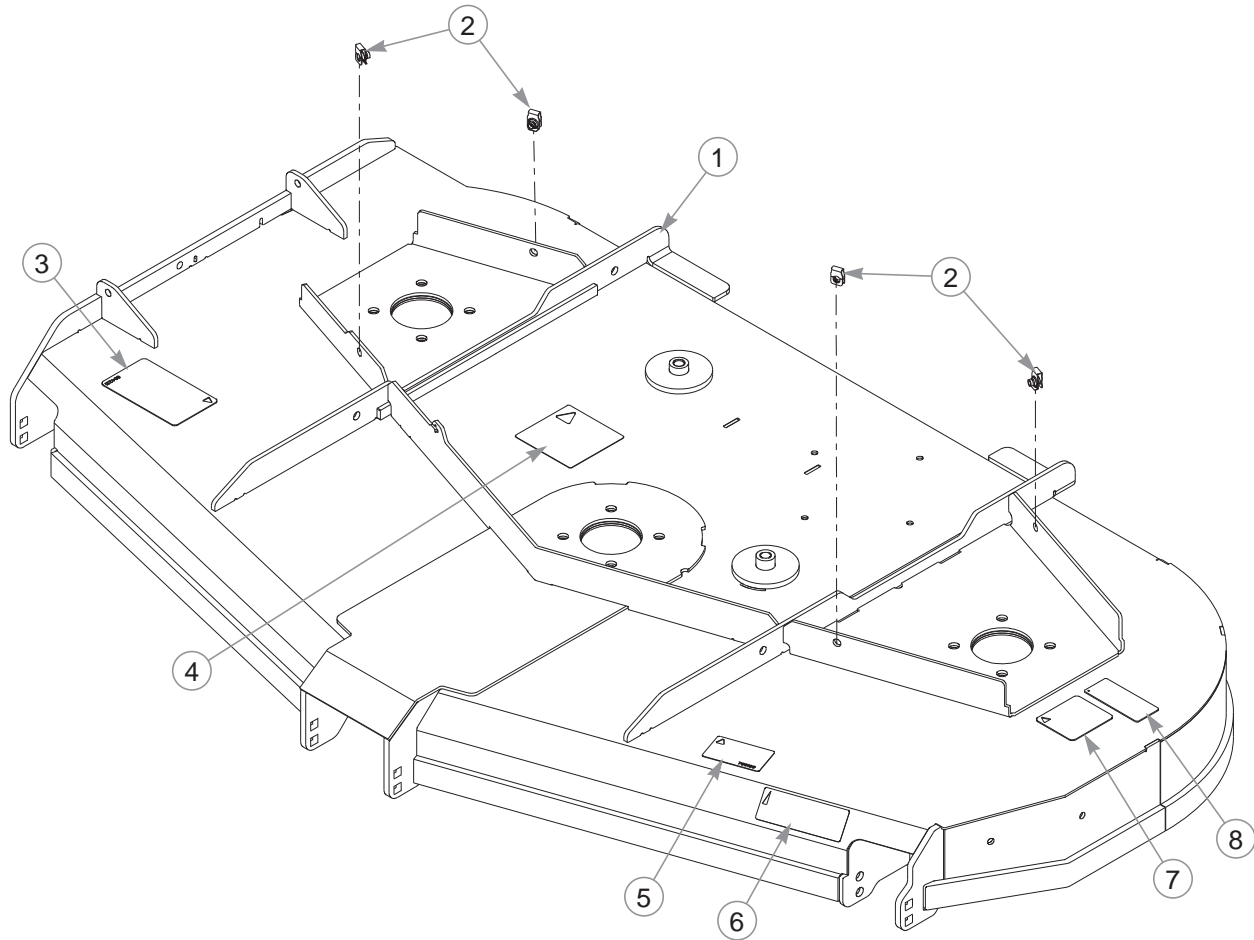

66" Service Deck

INDEX NO.	PART NO.	QTY.	DESCRIPTION
1	550750	1	66" VX4 DECK(WITH DECALS & HARDWARE)
2	601069	4	CN .312-18 X .20 MAX THK
3	604221	1	DANGER/CHUTE DECAL
4	781419	1	BELT ROUTING DECAL
5	799189	1	66" DECK ID DECAL
6	603092	1	VX4 TECHNOLOGY DECAL
7	601837	1	DECK DANGERS DECAL
8	601892	1	THROWN OBJECTS DECAL

NOTES:

66" Deck Pulleys & Spindles

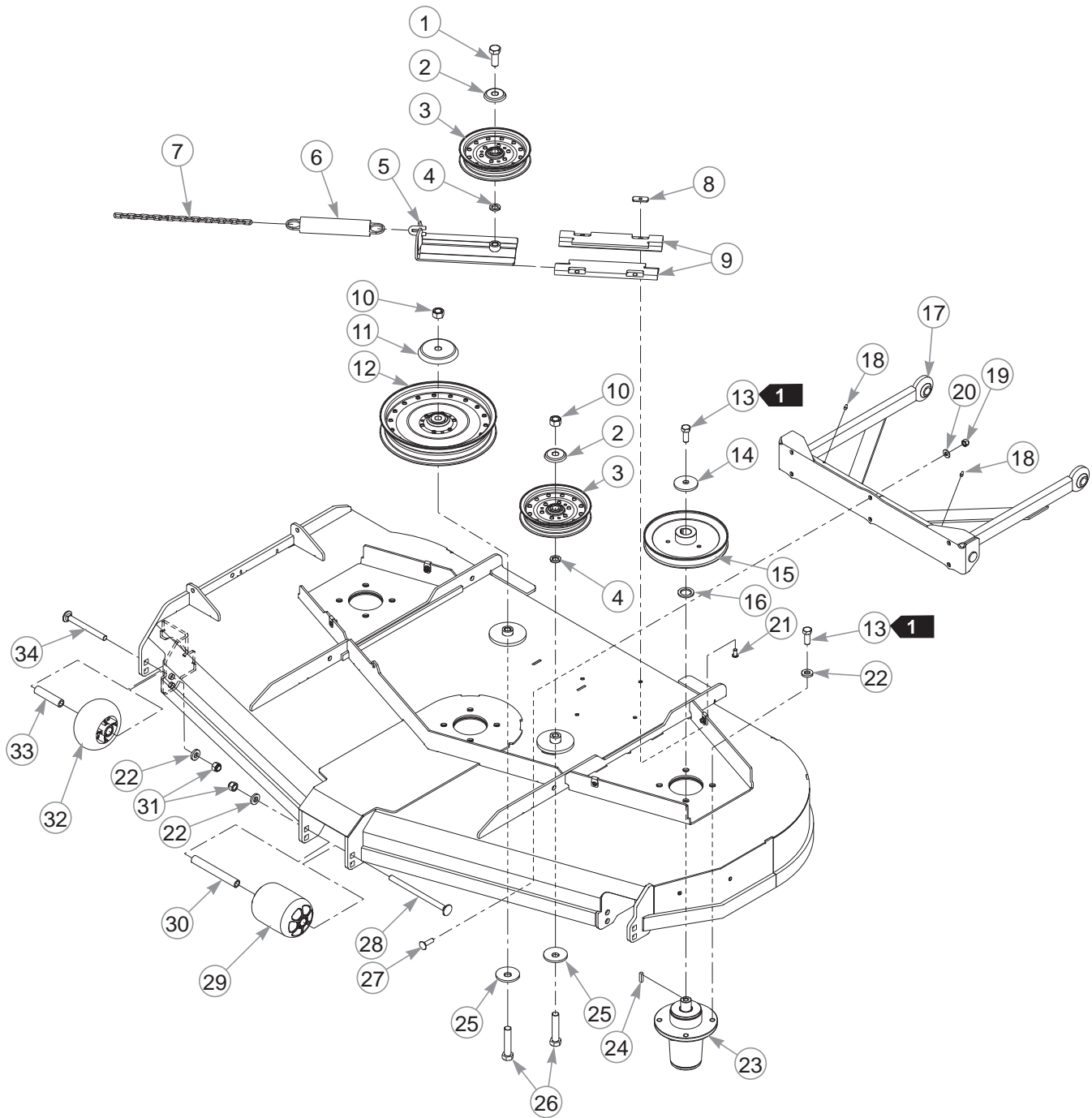

66" Deck Pulleys & Spindles

INDEX NO.	PART NO.	QTY.	DESCRIPTION
1	794446	1	CS .625-11 X 1.50 HX G5
2	602935	2	IDLER DUST SHIELD SM
3	602821	2	IDLER 6.0" RIVETED
4	028118	2	FW .625 X 1.00 X .134
5	350884	1	DECK IDLER SLIDE
6	781302	1	TENSION SPRING
7	373191	1	CHAIN, 21 LINK
8	603023	4	WN .312-18 ZN
9	602936	2	UHMW IDLER SLIDE
10	016972	2	NT .625-11 HX G5 ZNYC
11	602963	1	IDLER DUST SHIELD LG
12	602743	1	IDLER 10.0" RIVETED
13	705954	15	CS .500-13 X 1.25 HX G5
14	752386	3	CW .515 X 2.25 X .204 BLK
15	602859	3	DRIVE PULLEY 7.85 EFF
16	045765	3	FW 1.030 X 1.50 X .134
17	113340	1	PUSHER
18	015495	2	GREASE FITTING STRAIGHT
19	086660	6	NT .375-16 HX G5 ZY NL
20	767954	6	FW .379 X .813 X .063
21	603022	4	CS .312-18 X .625 BH ZN
22	767962	15	FW .531 X 1.063 X .175
23	604255	3	BLADE SPINDLE CW
24	212472	3	KEY 1/4 SQ X 1.00
25	782474	2	CW .631 X 2.25 X .187 PNT
26	783738	2	CS .625-11 X 3.00 FULL HX G5
27	603113	6	CB .375-16 X 1.25 G5 ZN
28	602338	1	CB .500-13 X 7.50 STD ZN
29	602341	1	PLASTIC WHEEL
30	602344	1	SPACER 5.73
31	781567	3	NT .500-13 HX G8 ZY NL
32	602263	2	PLASTIC WHEEL
33	602345	2	SPACER 3.22
34	603049	2	CB .500-13 X 5.00 ZNYC

NOTES:

1. Torque to 67–75 ft-lbs.

66" Deck

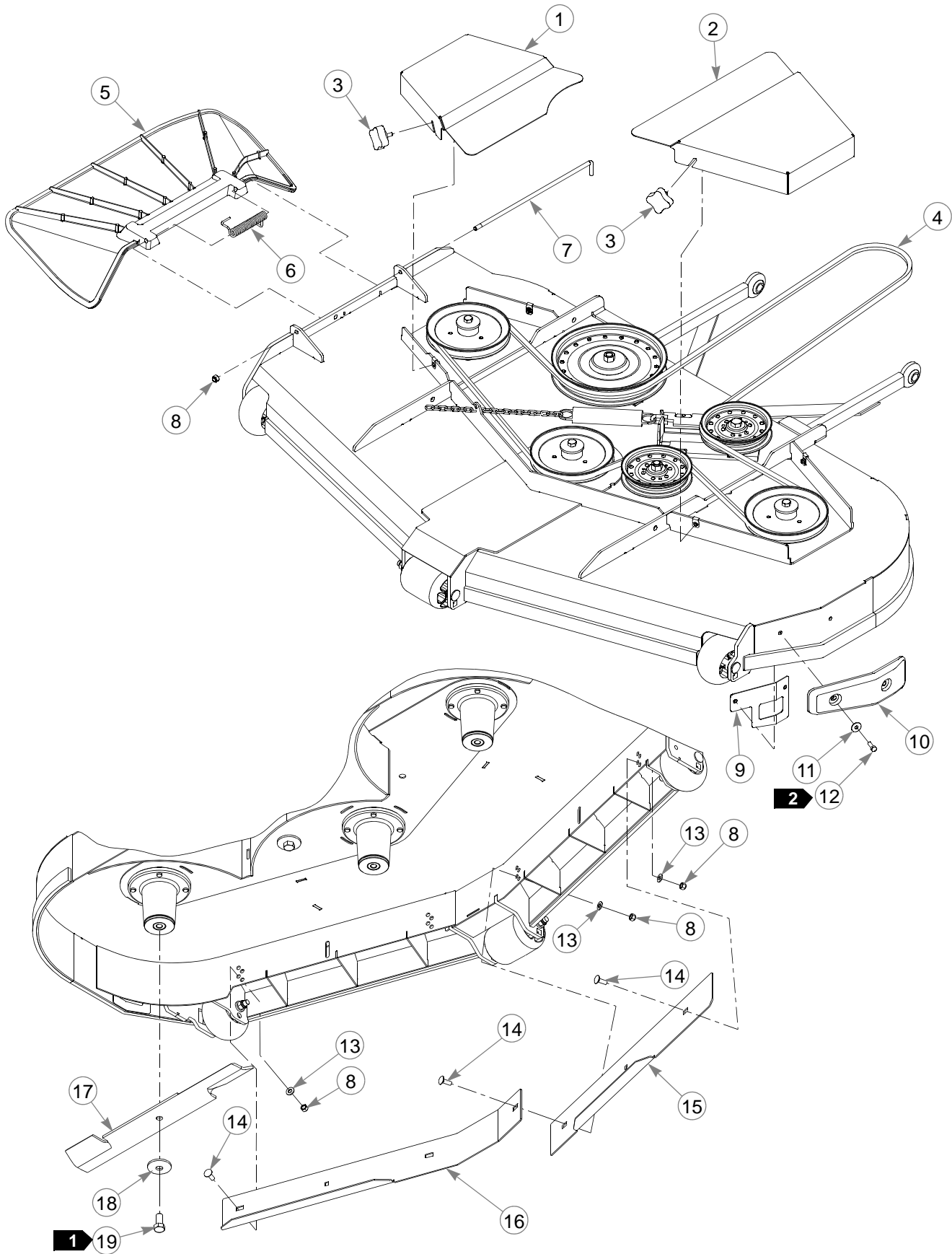

66" Deck

INDEX NO.	PART NO.	QTY.	DESCRIPTION
1	113335	1	RS PULLEY COVER
2	113336	1	LS PULLEY COVER
3	792002	4	KNOB 5/16-18 X 3/4"
4	602854	1	BELT, B-SEC
5	602891	1	DISCHARGE CHUTE LG
6	602435	1	TORSION SPRING
7	602432	1	CHUTE PIN
8	086660	7	NT .375-16 HX G5 ZY NL
9	113563	1	BACKING PLATE
10	602817	1	RUBBER BUMPER
11	079210	2	FW .344 X 1.00 X .06 ZNYC
12	064014	2	CS .312-18 X .875 HX G5 ZN
13	767954	6	FW .379 X .813 X .063
14	025395	6	CB .375-16 X 1.00 G5 ZNY
15	113333	1	RS INNER WALL ADJ.
16	113334	1	LS INNER WALL ADJ.
17	602864	3	BLADE, F22.50" EHN-F-CW
	798496	3	BLADE, F22.50" -H-F-CW
	798512	3	BLADE, 22.50" -GAT-F-CW
	798504	3	BLADE, 22.50" -MUL-F-CW
18	782474	3	CW .631 X 2.25 X .187 PNT
19	781872	3	CS .625-11 X 1.25 HX G5 Z

NOTES:

1. Torque to 118 ft-lbs.
2. Torque to 10 ft-lbs.

72" Side Discharge Service Deck

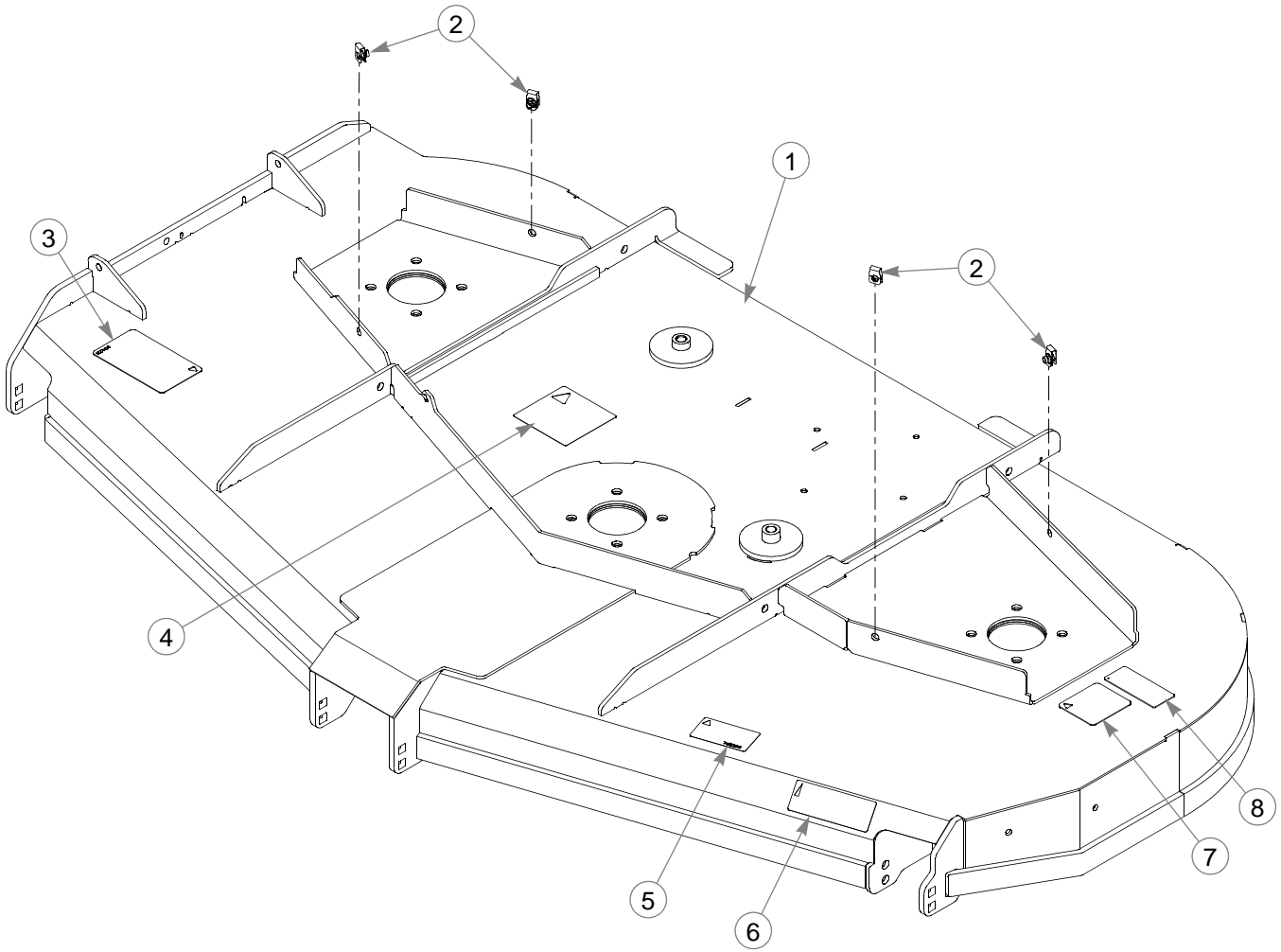

72" Side Discharge Service Deck

INDEX NO.	PART NO.	QTY.	DESCRIPTION
1	550751	1	72" VX4 DECK (WITH DECALS & HARDWARE)
2	601069	4	CN .312-18 X .20 MAX THK
3	604221	1	DANGER/CHUTE DECAL
4	781419	1	BELT ROUTING DECAL
5	786285	1	72" DECK ID DECAL
6	603092	1	VX4 TECHNOLOGY DECAL
7	601837	1	DECK DANGERS DECAL
8	601892	1	THROWN OBJECTS DECAL

NOTES:

72" Side Discharge Deck Pulleys & Spindles

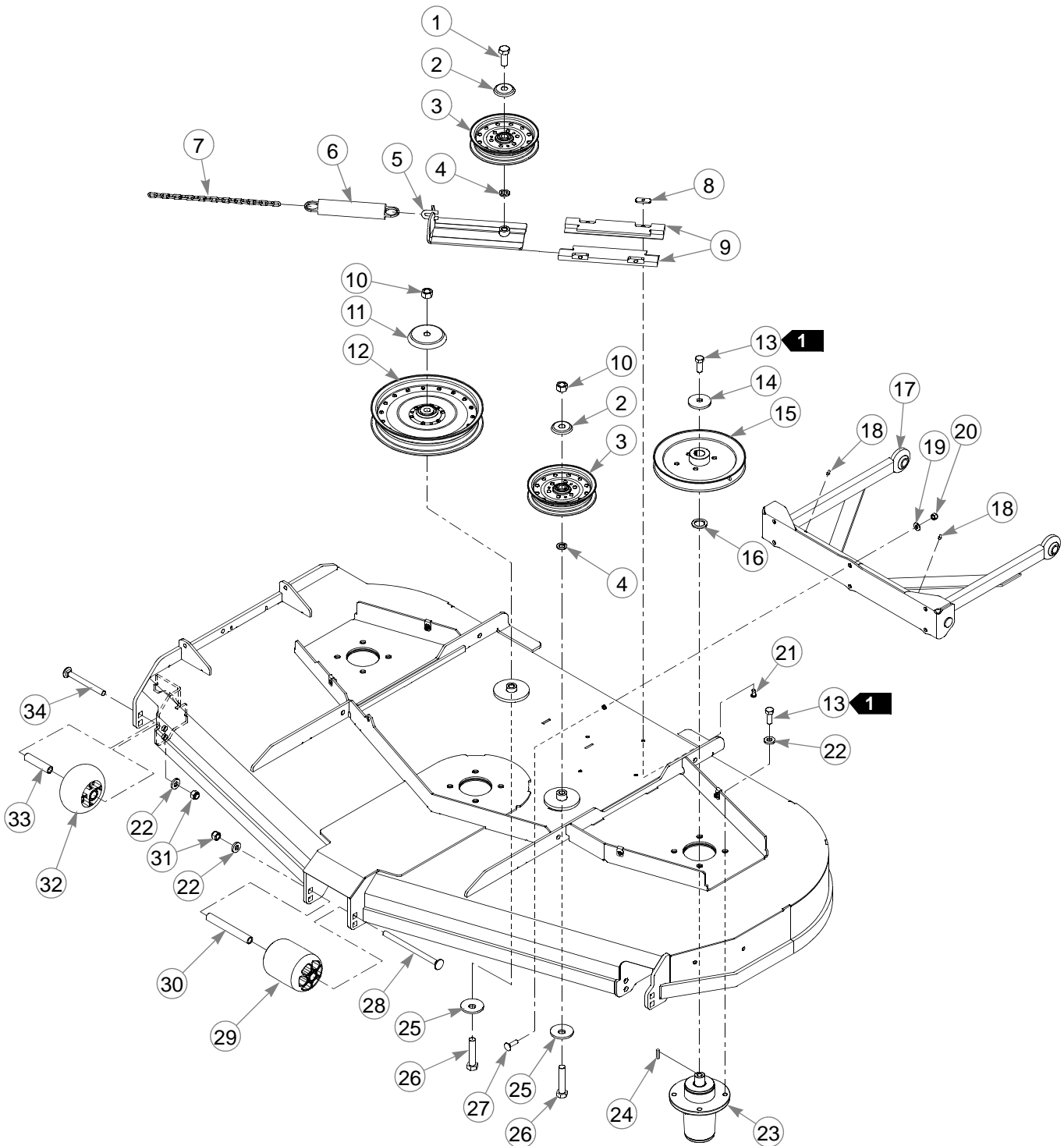

72" Side Discharge Deck Pulleys & Spindles

INDEX NO.	PART NO.	QTY.	DESCRIPTION
1	794446	1	CS .625-11 X 1.50 HX G5
2	602935	2	IDLER DUST SHIELD SM
3	602821	2	IDLER 6.0" RIVETED
4	028118	2	FW .625 X 1.00 X .134
5	350884	1	DECK IDLER SLIDE
6	781302	1	TENSION SPRING
7	373191	1	CHAIN, 21 LINK
8	603023	4	WN .312-18 ZN
9	602936	2	UHMW IDLER SLIDE
10	016972	2	NT .625-11 HX G5 ZNYC
11	602963	1	IDLER DUST SHIELD LG
12	602743	1	IDLER 10.0" RIVETED
13	705954	15	CS .500-13 X 1.25 HX G5
14	752386	3	CW .515 X 2.25 X .204 BLK
15	602746	3	DRIVE PULLEY 8.652 OP
16	045765	3	FW 1.030 X 1.50 X .134
17	113340	1	PUSHER
18	015495	2	GREASE FITTING STRAIGHT
19	767954	6	FW .379 X .813 X .063
20	086660	6	NT .375-16 HX G5 ZY NL
21	603022	4	CS .312-18 X .625 BH ZN
22	767962	15	FW .531 X 1.063 X .175
23	604255	3	BLADE SPINDLE CW
24	212472	3	KEY 1/4 SQ X 1.00
25	782474	2	CW .631 X 2.25 X .187 PNT
26	783738	2	CS .625-11 X 3.00 FULL HX G5
27	603113	6	CB .375-16 X 1.25 G5 ZN
28	602338	1	CB .500-13 X 7.50 STD ZN
29	602341	1	PLASTIC WHEEL
30	602344	1	SPACER 5.73
31	781567	3	NT .500-13 HX G8 ZY NL
32	602263	2	PLASTIC WHEEL
33	602345	2	SPACER 3.22
34	603049	2	CB .500-13 X 5.00 ZNYC

NOTES:

1. Torque to 67–75 ft-lbs.

72" Side Discharge Deck

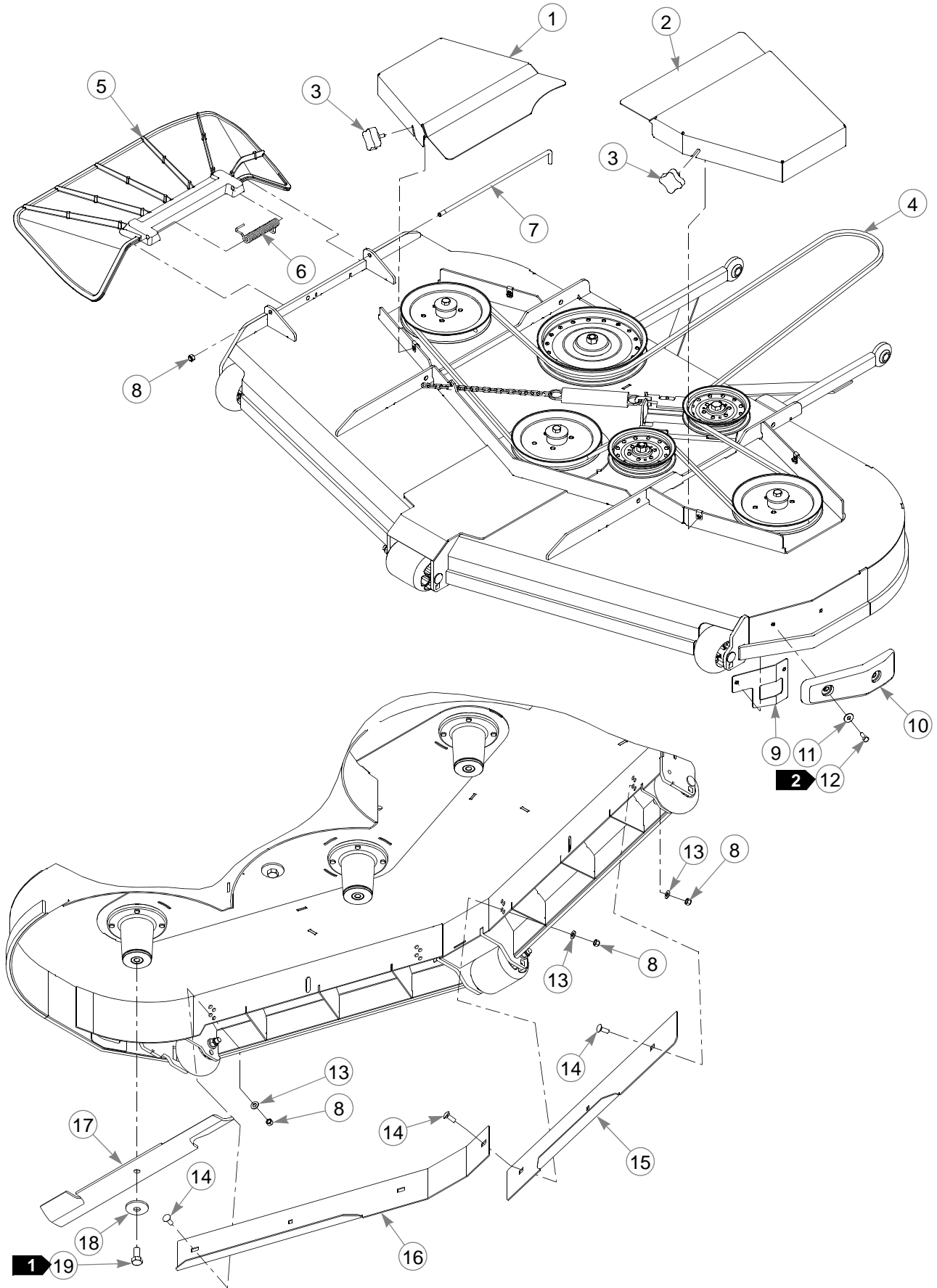

72" Side Discharge Deck

INDEX NO.	PART NO.	QTY.	DESCRIPTION
1	112935	1	RS PULLEY COVER
2	112936	1	LS PULLEY COVER
3	792002	4	KNOB 5/16-18 X 3/4"
4	784207	1	BELT, B 195" EL
5	602891	1	DISCHARGE CHUTE LG
6	602435	1	TORSION SPRING
7	602432	1	CHUTE PIN
8	086660	7	NT .375-16 HX G5 ZY NL
9	113563	1	BACKING PLATE
10	602817	1	RUBBER BUMPER
11	079210	2	FW .344 X 1.00 X .06 ZNYC
12	064014	2	CS .312-18 X .875 HX G5 ZN
13	767954	6	FW .379 X .813 X .063
14	025395	6	CB .375-16 X 1.00 G5 ZNY
15	112931	1	RS INNER WALL ADJ.
16	112932	1	LS INNER WALL ADJ.
17	602857	3	BLADE, F24.50" -EHN-F-CW
	798702	3	BLADE, F24.50" -H-F-CW
	798710	3	BLADE, 24.50" -MUL-F-CW
	798728	3	BLADE, 24.50" -GAT-F-CW
18	782474	3	CW .631 X 2.25 X .187 PNT
19	781872	3	CS .625-11 X 1.25 HX G5 Z

NOTES:

1. Torque to 118 ft-lbs.
2. Torque to 10 ft-lbs.

60" Rear Discharge Service Deck

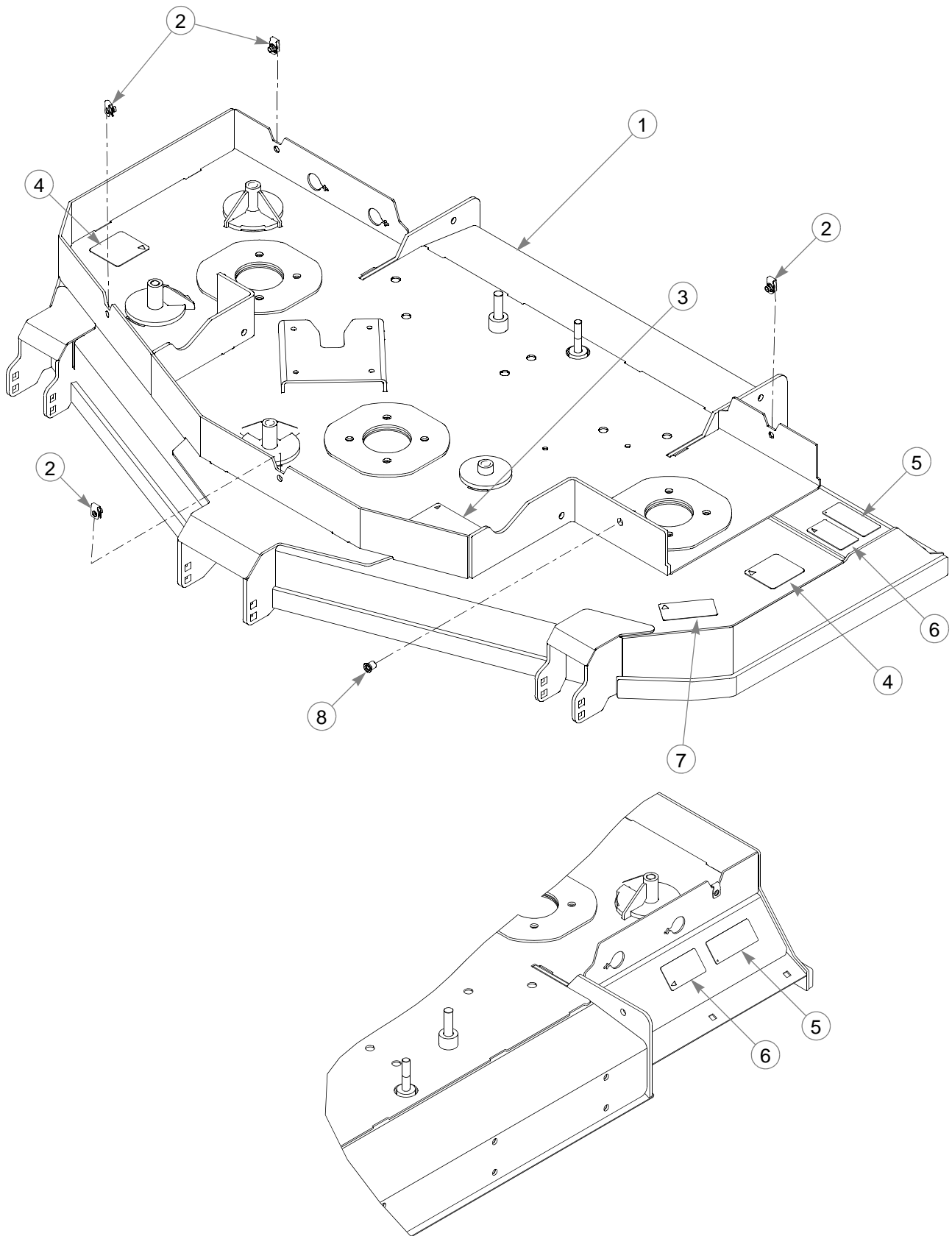

60" Rear Discharge Service Deck

INDEX NO.	PART NO.	QTY.	DESCRIPTION
1	550935	1	60" RD DECK (WITH DECALS & HARDWARE)
2	601069	4	CN .312-18 X .20 MAX THK
3	603349	1	2 BELT ROUTING DECAL
4	601837	2	DECK DANGERS DECAL
5	601892	2	THROWN OBJECTS DECAL
6	603391	2	RUBBER FLAP DECAL
7	786277	1	60" DECK ID DECAL
8	792887	1	5/16-18 THREAD HEX RIVET NUT

NOTES:

60" Rear Discharge Deck Pulleys & Spindles

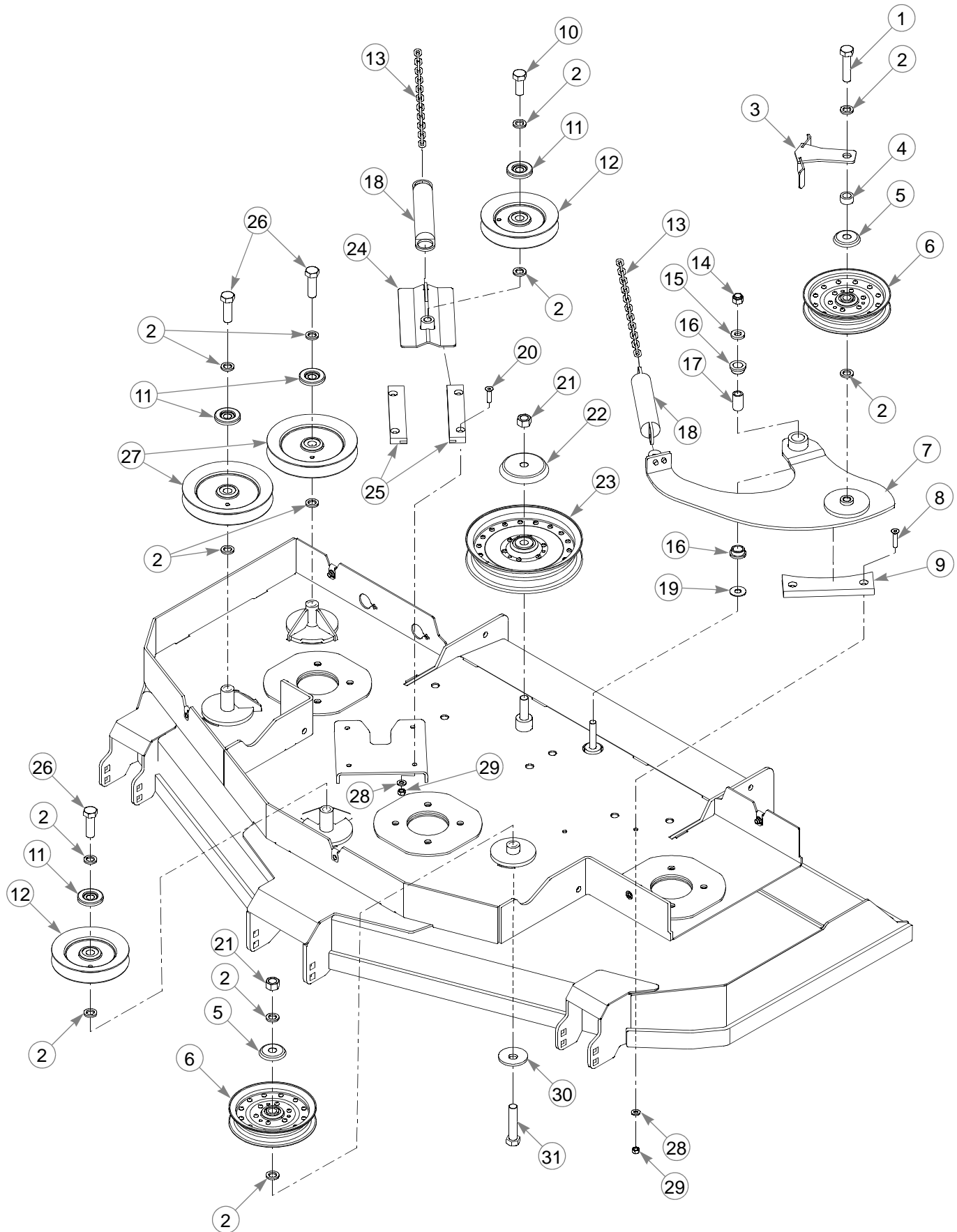

60" Rear Discharge Deck Pulleys & Spindles

INDEX NO.	PART NO.	QTY.	DESCRIPTION
1	025015	1	CS .625-11 X 2.50 HX G5
2	028118	12	FW .625 X 1.00 X .134
3	113088	1	BELT GUIDE
4	603256	1	DECK IDLER SPACER 1/2" LG
5	602935	2	IDLER DUST SHIELD SM
6	602821	2	IDLER 6.0" RIVETED
7	114133	1	RD DECK IDLER ARM
8	797910	2	CS .312-18 X 1.50 FLT SH ZY
9	601779	1	IDLER GUIDE
10	794446	1	CS .625-11 X 1.50 HX G5
11	603057	4	DUST SHIELD WITH OFFSET
12	602672	2	PULLEY V-IDLER HBB 5.0"
13	373191	2	CHAIN, 21 LINK
14	781567	1	NT .500-13 HX G8 ZY NL
15	767962	13	FW .531 X 1.063 X .175
16	770867	2	PLASTIC BUSHING .750 X 1
17	109549	1	IDLER PIVOT BUSHING
18	781302	2	TENSION SPRING
19	704759	1	FW .500 X 1.25 X .075 ZNY
20	784199	4	CS .312-18 X 1.25 FLT SH
21	016972	2	NT .625-11 HX G5 ZNYC
22	602963	1	IDLER DUST SHIELD LG
23	602838	1	IDLER 8.0" RIVETED
24	114105	1	IDLER SLIDE
25	601619	2	IDLER SLIDE UHMW
26	016642	3	CS .625-11 X 2.00 HX G5 Z
27	796714	2	6" HB IDLER PULLEY
28	768523	6	FW .343 X .687 X .051/.080H
29	058776	6	NT .312-18 HX G5 ZY NL
30	782474	1	CW .631 X 2.25 X .187 PNT
31	783738	1	CS .625-11 X 3.00 FULL HX G5

NOTES:

60" Rear Discharge Deck Pulleys & Spindles

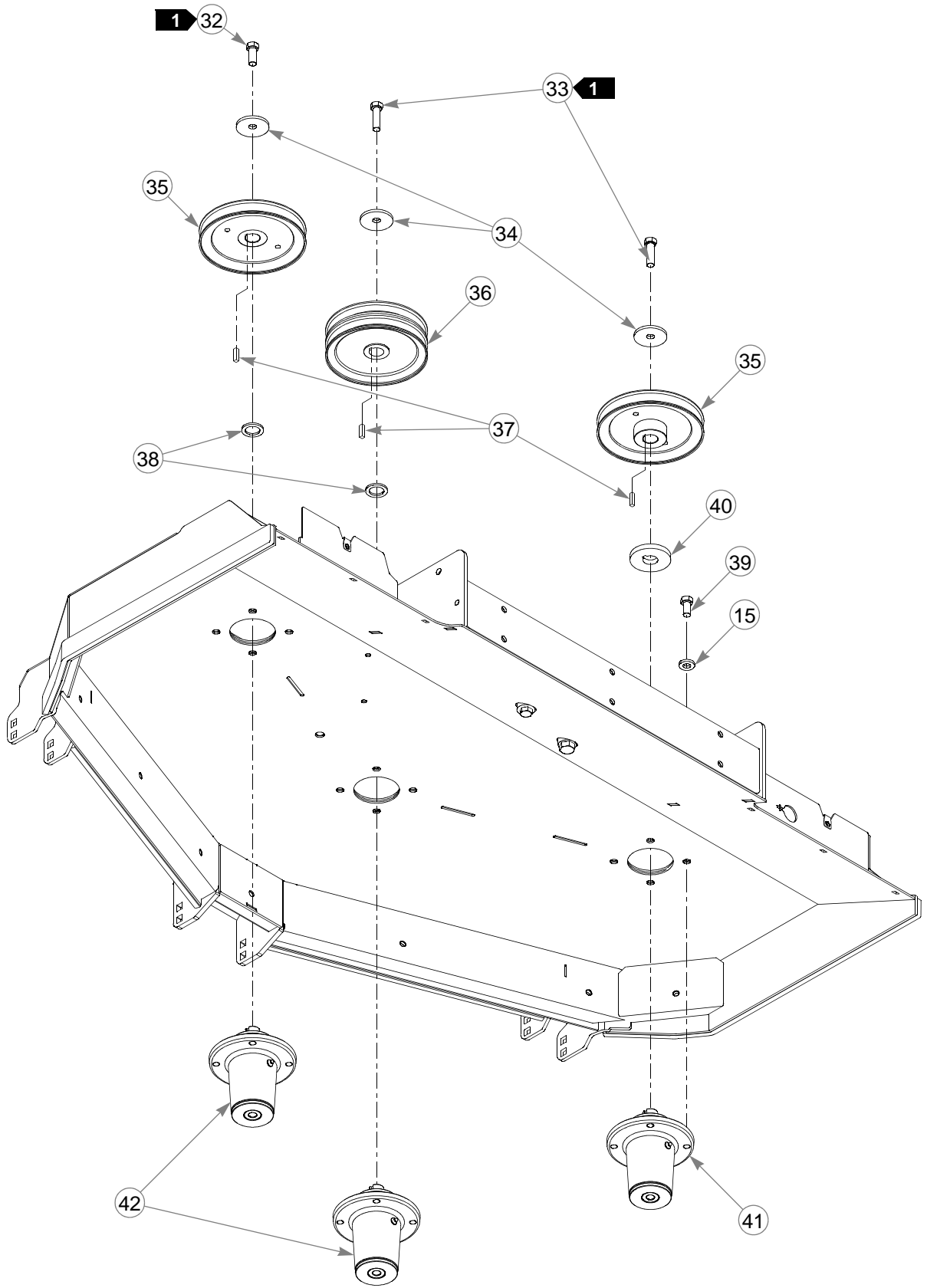

60" Rear Discharge Deck Pulleys & Spindles

INDEX NO.	PART NO.	QTY.	DESCRIPTION
32	705954	1	CS .500-13 X 1.25 HX G5
33	017616	2	CS .500-13 X 1.75 HX G5
34	752386	3	CW .515 X 2.25 X .204 BLK
35	602745	2	PULLEY DRIVE 7.00 EFF
36	770388	1	PULLEY
37	212472	3	KEY 1/4 SQ X 1.00
38	045765	2	FW 1.030 X 1.50 X .134
39	016527	12	CS .500-13 X 1.00 HX G5 ZN
40	114108	1	SPACER
41	604256	1	BLADE SPINDLE CCW
42	604255	2	BLADE SPINDLE CW

NOTES:

1. Torque to 65–75 ft-lbs.

60" Rear Discharge Dust Shield

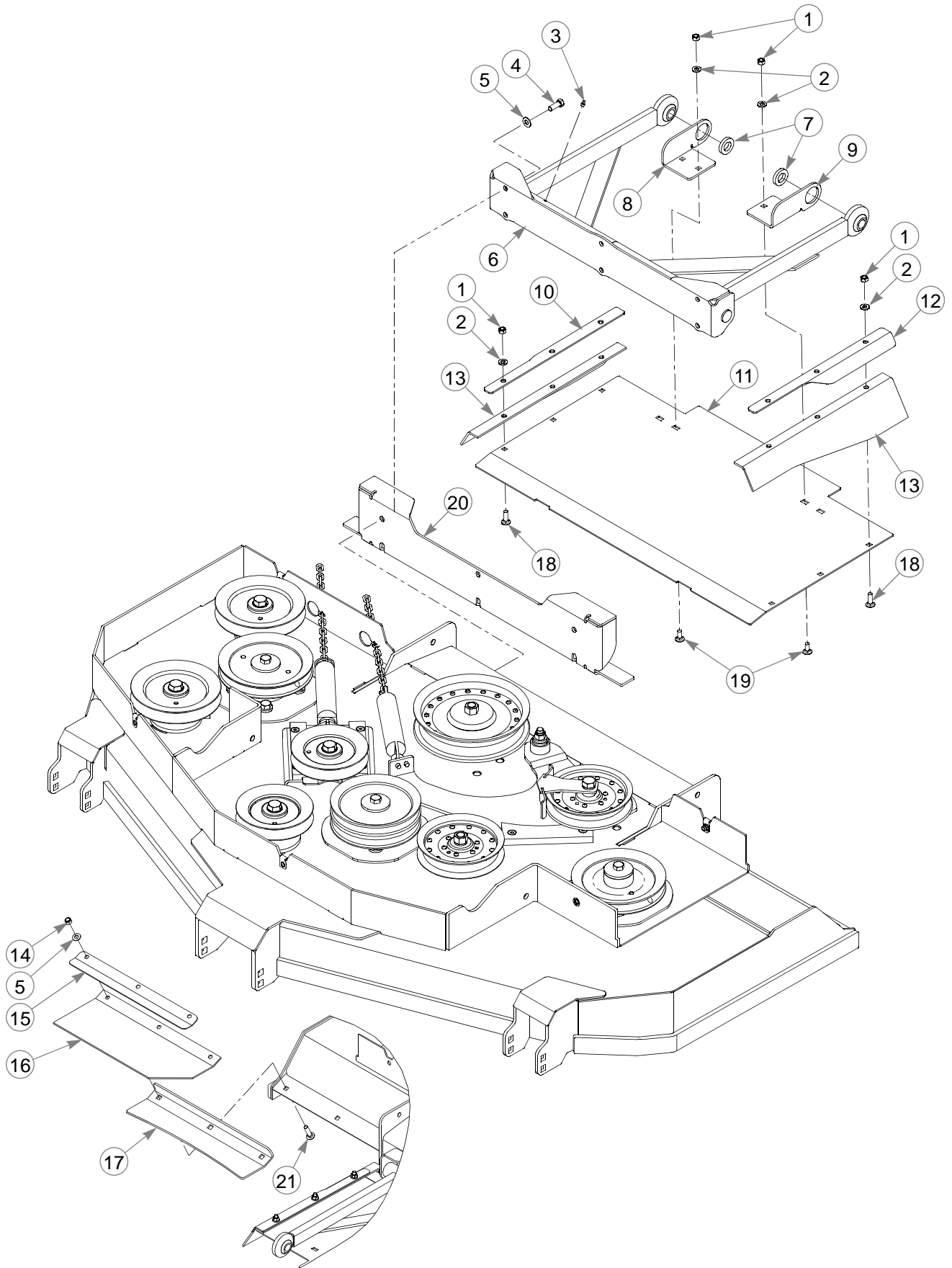

60" Rear Discharge Dust Shield

INDEX NO.	PART NO.	QTY.	DESCRIPTION
1	058776	10	NT .312-18 HX G5 ZY
2	768523	10	FW .343 X .687 X .051/.080H
3	015495	2	GREASE FITTING STRAIGHT
4	036244	6	CS .375-16 X 1.00 HX G5
5	767954	12	FW .379 X .813 X .063
6	113340	1	PUSHER
7	778399	2	FW .781 X 1.375 X .250 ZNY
8	109482	1	RS CHUTE BRACKET
9	109483	1	LS CHUTE BRACKET
10	109487	1	RS CLAMP ANGLE
11	114440	1	DUST SHIELD
12	109486	1	LS CLAMP ANGLE
13	601483	2	RUBBER SIDE FLAP
14	086660	6	NT .375-16 HX G5 ZY NL
15	106716	2	DISCHARGE CHUTE ANGLE
16	600254	2	RD REAR FLAP
17	351676	2	DECK STIFFENER ANGLE
18	037887	6	CB .312-18 X 1.00 FULL ZN
19	016253	4	CB .312-18 X .75 FUL ZN
20	114522	1	REAR DECK STOP
21	710194	6	CB .375-16 X 1.50 STD G5

NOTES:

60" Rear Discharge Deck

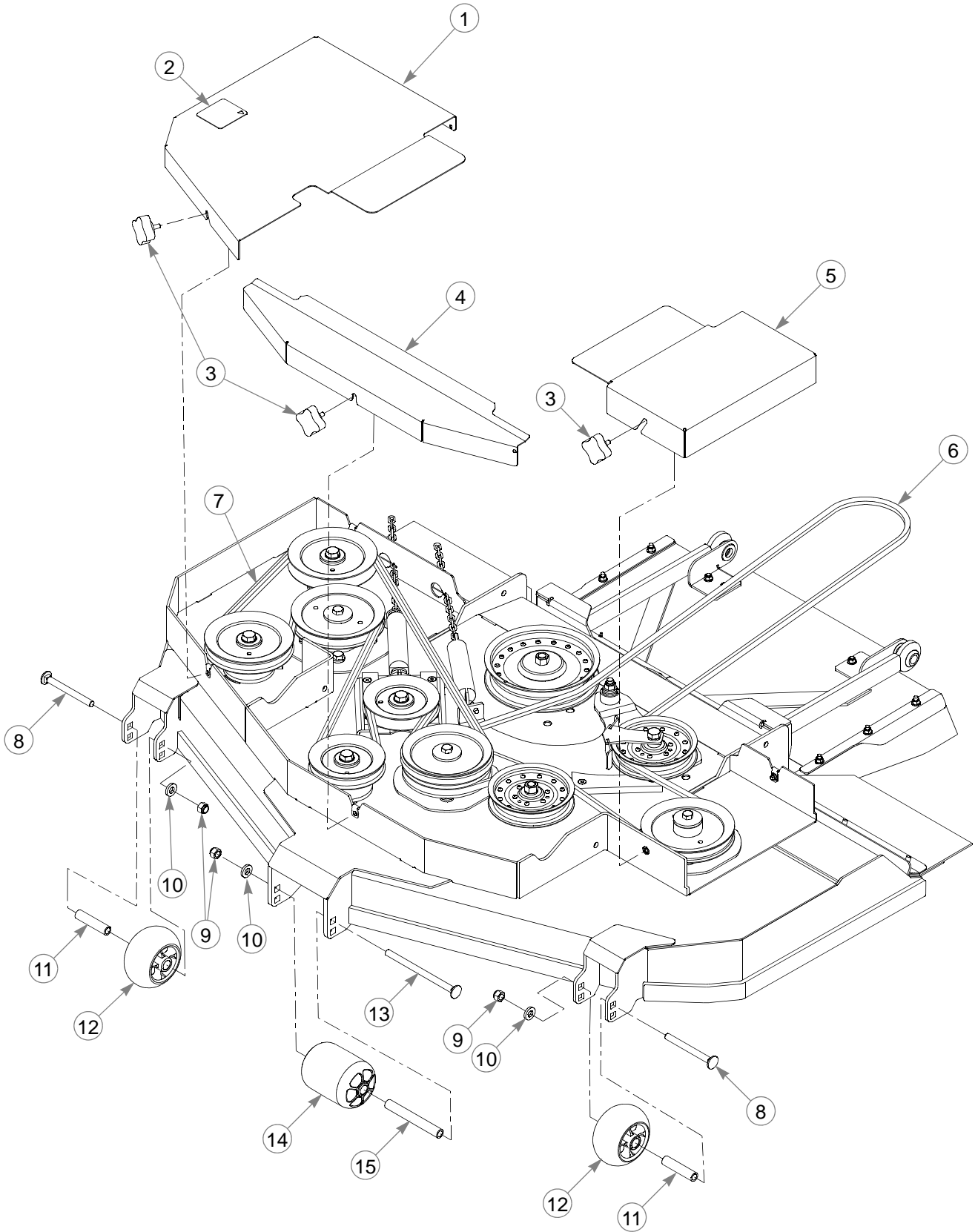

60" Rear Discharge Deck

INDEX NO.	PART NO.	QTY.	DESCRIPTION
1	550939	1	RS PULLEY COVER (WITH DECALS)
2	601837	1	DECK DANGERS DECAL
3	792002	5	KNOB 5/16-18 X 3/4"
4	550938	1	CENTER PULLEY COVER
5	114210	1	LS PULLEY COVER
6	777185	1	BELT, B 145.5" EL
7	027284	1	BELT, B 138" EL
8	603049	2	CB .500-13 X 5.00 ZNYC
9	781567	3	NT .500-13 HX G8 ZY NL
10	767962	3	FW .531 X 1.063 X .175
11	602345	2	SPACER 3.22
12	602263	2	PLASTIC WHEEL
13	602338	1	CB .500-13 X 7.50 STD ZN
14	602341	1	PLASTIC WHEEL
15	602344	1	SPACER 5.73

NOTES:

60" Rear Discharge Deck

INDEX NO.	PART NO.	QTY.	DESCRIPTION
16	055822	6	CS .375-16 X .75 HX G5
17	767954	6	FW .379 X .813 X .063
18	114205	1	LS ADJUSTABLE BAFFLE
19	114204	1	RS ADJUSTABLE BAFFLE
20	795633	1	BLADE, F20.50"-L-F-CCW
	601928	1	BLADE, 20.50" GAT-F-CCW
21	782474	3	CW .631 X 2.25 X .187 PNT
22	604383	1	CS .625-11 X 1.25 HX G5 LH THREAD
23	600901	2	BLADE, F20.50"-L-F-CW
	794230	2	BLADE, 20.50" GAT-F-CW
24	781872	2	CS .625-11 X 1.25 HX G5 Z

NOTES:

1. Torque to 118 ft-lbs.

72" Rear Discharge Service Deck

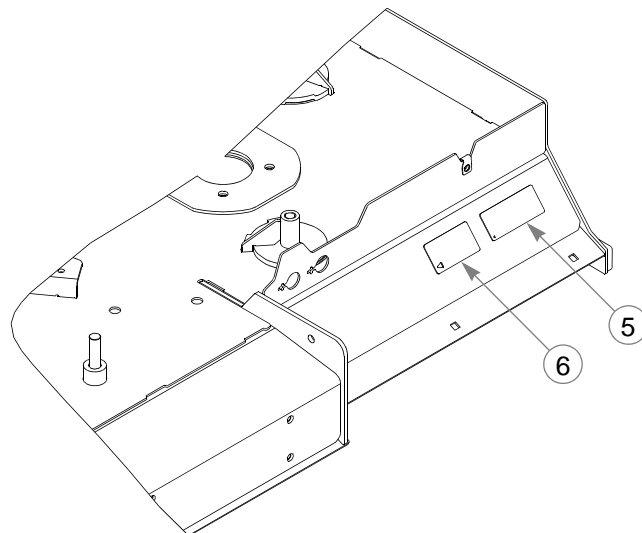
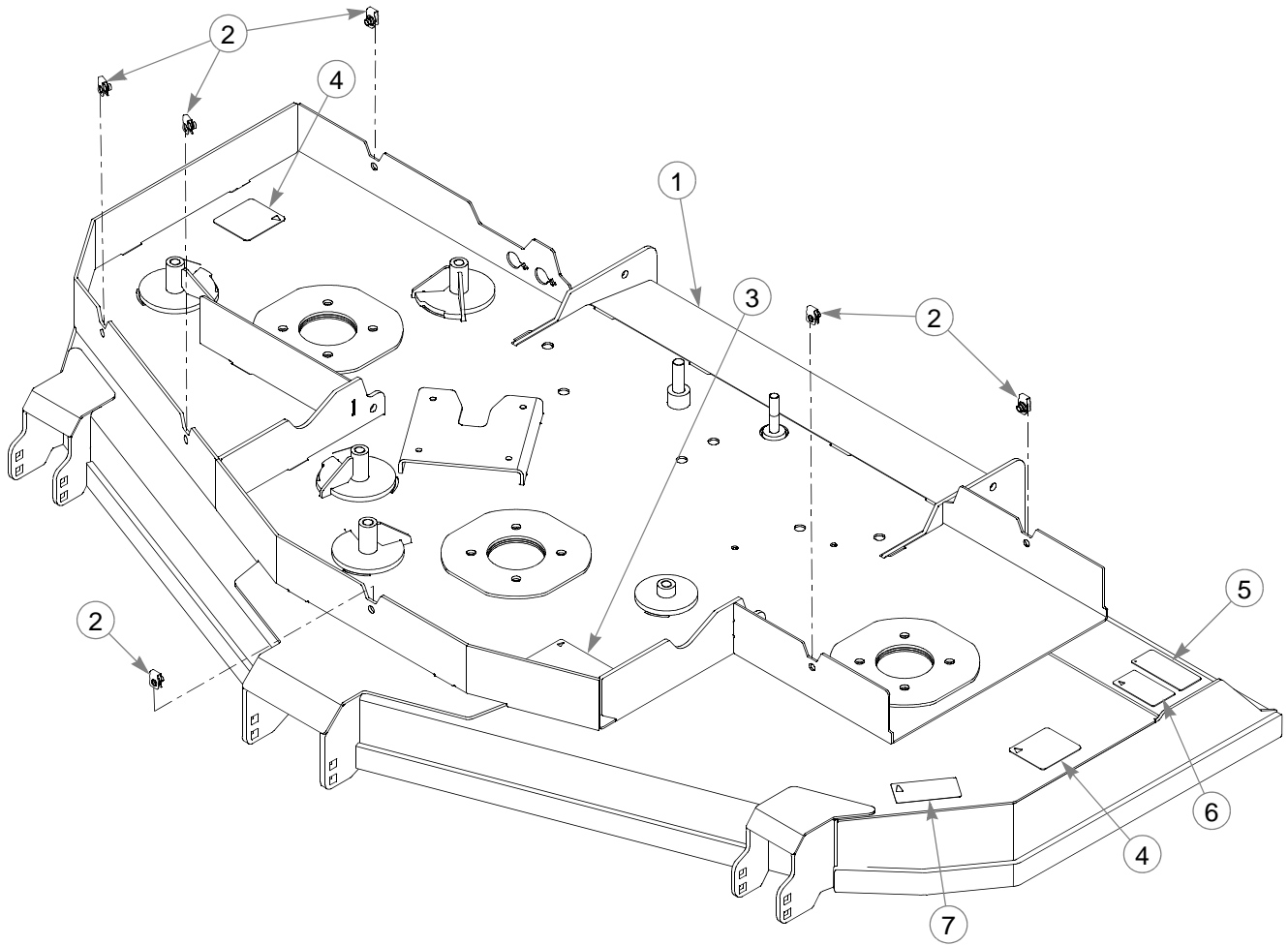

72" Rear Discharge Service Deck

INDEX NO.	PART NO.	QTY.	DESCRIPTION
1	551049	1	72" RD DECK (WITH DECALS & HARDWARE)
2	601069	6	CN .312-18 X .20 MAX THK
3	603349	1	2 BELT ROUTING DECAL
4	601837	2	DECK DANGERS DECAL
5	601892	2	THROWN OBJECTS DECAL
6	603391	2	RUBBER FLAP DECAL
7	786285	1	72" DECK ID DECAL

NOTES:

72" Rear Discharge Deck Pulleys & Spindles

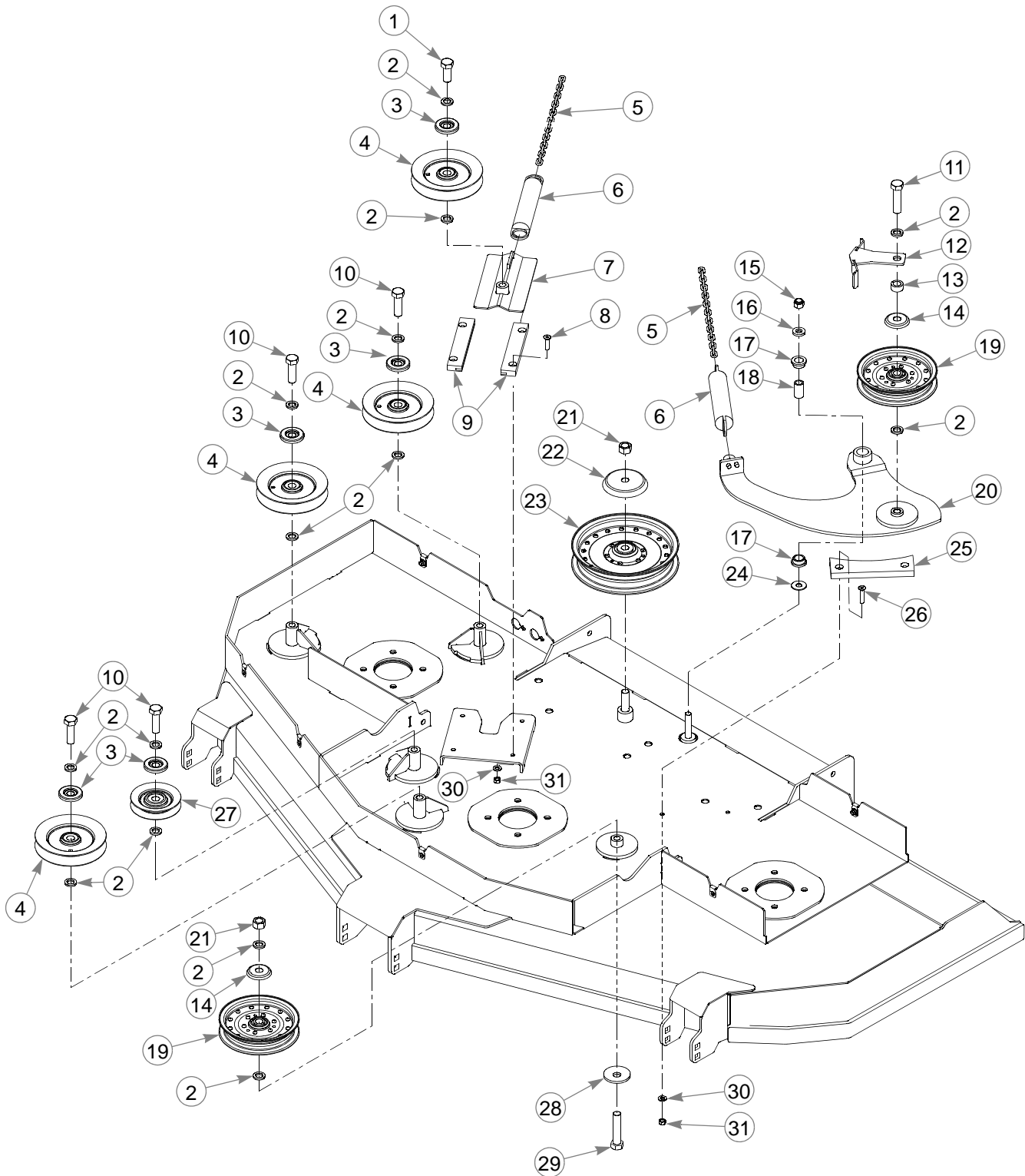

72" Rear Discharge Deck Pulleys & Spindles

INDEX NO.	PART NO.	QTY.	DESCRIPTION
1	794446	1	CS .625-11 X 1.50 HX G5
2	028118	14	FW .625 X 1.00 X .134
3	603057	5	DUST SHIELD WITH OFFSET
4	602672	4	PULLEY V-IDLER HBB 5.0"
5	373191	2	CHAIN, 21 LINK
6	781302	2	TENSION SPRING
7	114105	1	IDLER SLIDE
8	784199	4	CS .312-18 X 1.25 FLT SH
9	601619	2	IDLER SLIDE UHMW
10	016642	4	CS .625-11 X 2.00 HX G5 Z
11	025015	1	CS .625-11 X 2.50 HX G5
12	113088	1	BELT GUIDE
13	603256	1	DECK IDLER SPACER 1/2" LG
14	602935	2	IDLER DUST SHIELD SM
15	781567	1	NT .500-13 HX G8 ZY NL
16	767962	13	FW .531 X 1.063 X .175
17	770867	2	BUSHING
18	109549	1	BUSHING
19	602821	2	IDLER 6.0" RIVETED
20	114133	1	RD DECK IDLER ARM
21	016972	2	NT .625-11 HX G5 ZNYC
22	602963	1	IDLER DUST SHIELD LG
23	602838	1	IDLER 8.0" RIVETED
24	704759	1	FW .500 X 1.25 X .075 ZNY
25	601779	1	IDLER GUIDE
26	797910	2	CS .312-18 X 1.50 FLT SH ZY
27	788364	1	IDLER PULLEY NHI 4.288"
28	782474	1	CW .631 X 2.25 X .187 PNT
29	783738	1	CS .625-11 X 3.00 FULL HX G5
30	768523	6	FW .343 X .687 X .051/.080H
31	058776	6	NT .312-18 HX G5 ZY NL

NOTES:

72" Rear Discharge Deck Pulleys & Spindles

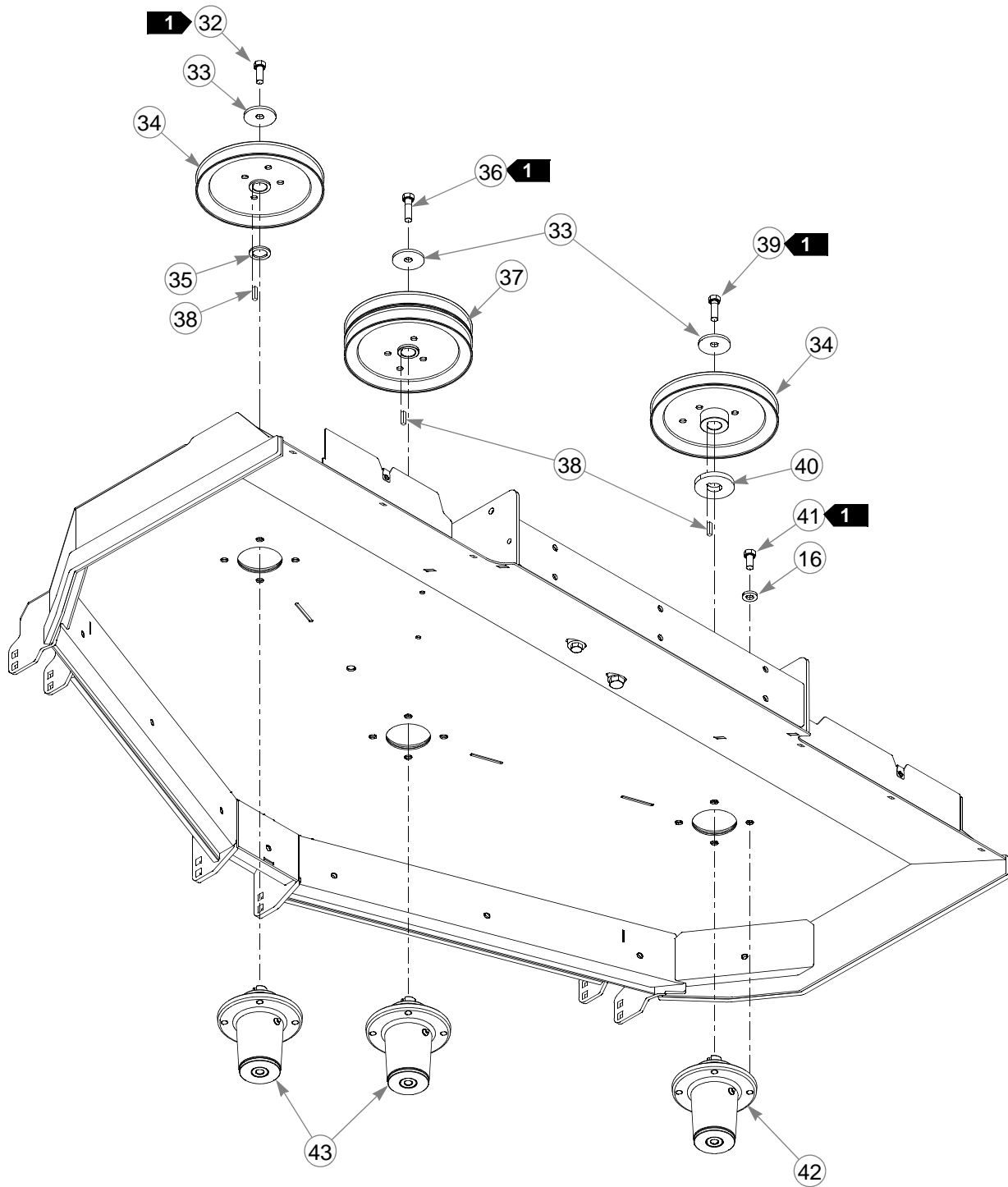

72" Rear Discharge Deck Pulleys & Spindles

INDEX NO.	PART NO.	QTY.	DESCRIPTION
32	705954	1	CS .500-13 X 1.25 HX G5
33	752386	3	CW .515 X 2.25 X .204 BLK
34	602746	2	DRIVE PULLEY 8.652 OP
35	045765	1	FW 1.030 X 1.50 X .134
36	017616	1	CS .500-13 X 1.75 HX G5
37	603226	1	DOUBLE PULLEY 8.41"
38	212472	3	KEY 1/4 SQ X 1.00
39	074252	1	CS .500-13 X 1.50 HX G5
40	114108	1	SPACER
41	016527	12	CS .500-13 X 1.00 HX G5 ZN
42	604256	1	BLADE SPINDLE CCW (S/N 12092683 & HIGHER)
	601819	1	BLADE SPINDLE CCW (S/N PRIOR TO 12092683)
43	604255	2	BLADE SPINDLE CW (S/N 12092683 & HIGHER)
	601630	2	BLADE SPINDLE CW (S/N PRIOR TO 12092683)

NOTES:

1. Torque to 65–75 ft-lbs.

72" Rear Discharge Dust Shield

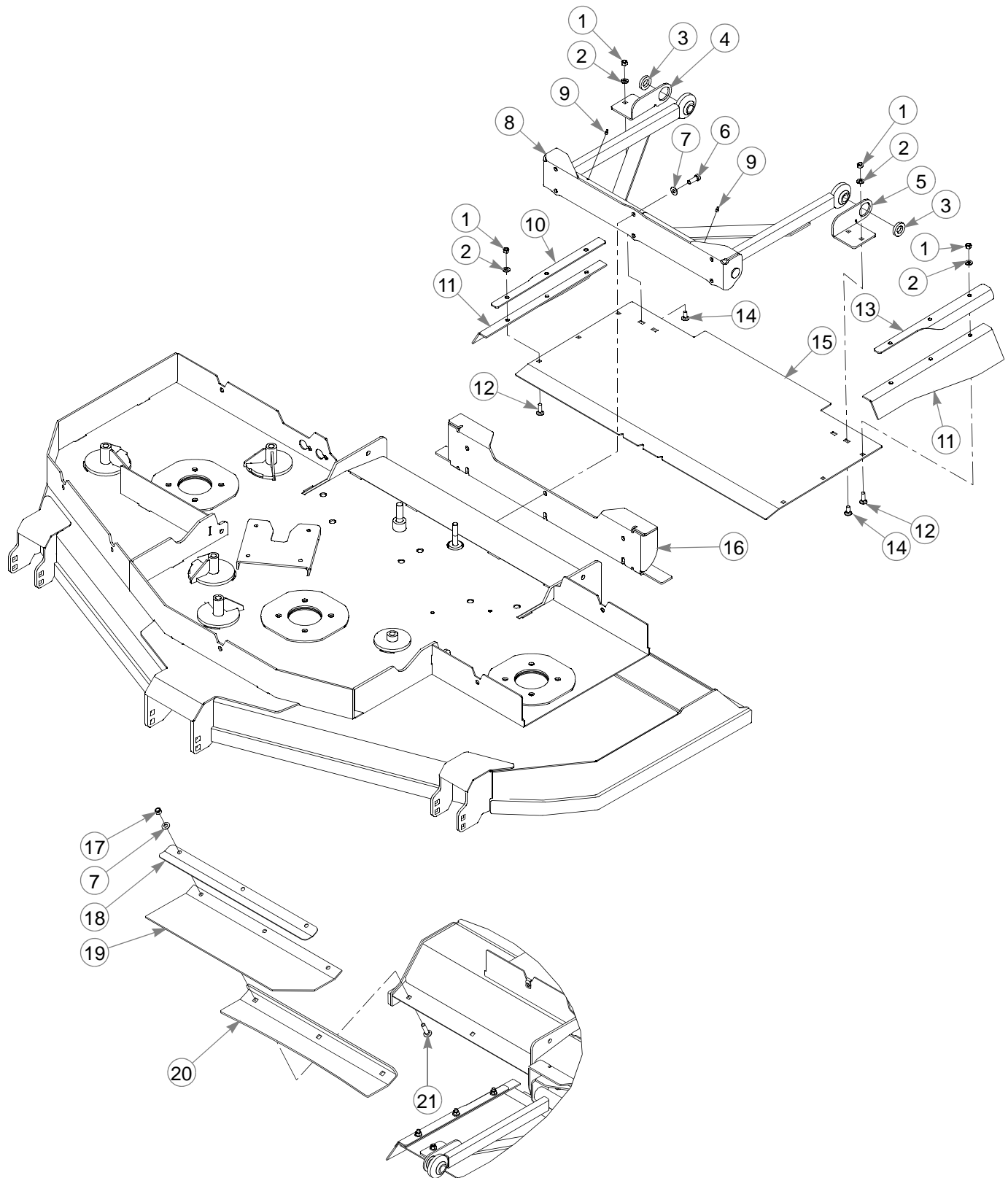

72" Rear Discharge Dust Shield

INDEX NO.	PART NO.	QTY.	DESCRIPTION
1	058776	10	NT .312-18 HX G5 ZY NL
2	768523	10	FW .343 X .687 X .051/.080H
3	778399	2	FW .781 X 1.375 X .250 ZNY
4	109483	1	LS CHUTE BRACKET
5	109482	1	RS CHUTE BRACKET
6	036244	6	CS .375-16 X 1.00 HX G5
7	767954	12	FW .379 X .813 X .063
8	113340	1	PUSHER
9	015495	2	GREASE FITTING STRAIGHT
10	109487	1	RS CLAMP ANGLE
11	601483	2	RUBBER SIDE FLAP
12	037887	6	CB .312-18 X 1.00 FULL ZN
13	109486	1	LS CLAMP ANGLE
14	016253	4	CB .312-18 X .75 FUL ZN
15	114653	1	DUST SHIELD
16	114522	1	REAR DECK STOP
17	086660	6	NT .375-16 HX G5 ZY NL
18	107712	2	DISCHARGE CHUTE ANGLE
19	600930	2	REAR FLAP
20	101360	2	DECK STIFFENER ANGLE
21	710194	6	CB .375-16 X 1.50 STD G5

NOTES:

72" Rear Discharge Deck

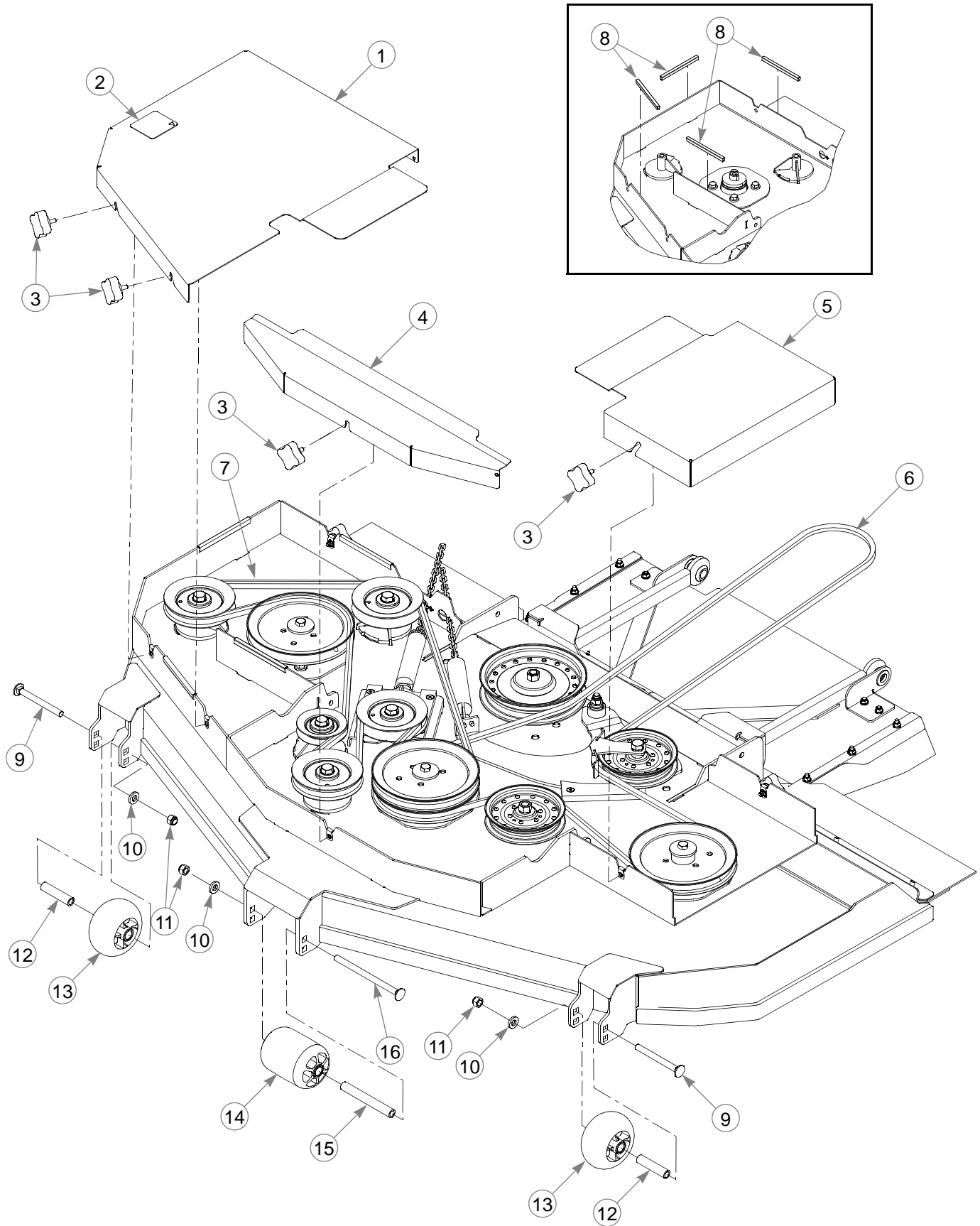

72" Rear Discharge Deck

INDEX NO.	PART NO.	QTY.	DESCRIPTION
1	551050	1	RS PULLEY COVER (WITH DECAL)
2	601837	1	DECK DANGERS DECAL
3	792002	6	KNOB 5/16-18 X 3/4"
4	114209	1	CENTER PULLEY COVER
5	114490	1	LS PULLEY COVER
6	797928	1	BELT, B 160.2" EL
7	603422	1	BELT, HBB SECTION 140.3
8	111339	4	FLEX TRIM
9	603049	2	CB .500-13 X 5.00 ZNYC
10	767962	3	FW .531 X 1.063 X .175
11	781567	3	NT .500-13 HX G8 ZY NL
12	602345	2	SPACER 3.22
13	602263	2	PLASTIC WHEEL
14	602341	1	PLASTIC WHEEL
15	602344	1	SPACER 5.73
16	602338	1	CB .500-13 X 7.50 STD ZN

NOTES:

72" Rear Discharge Deck

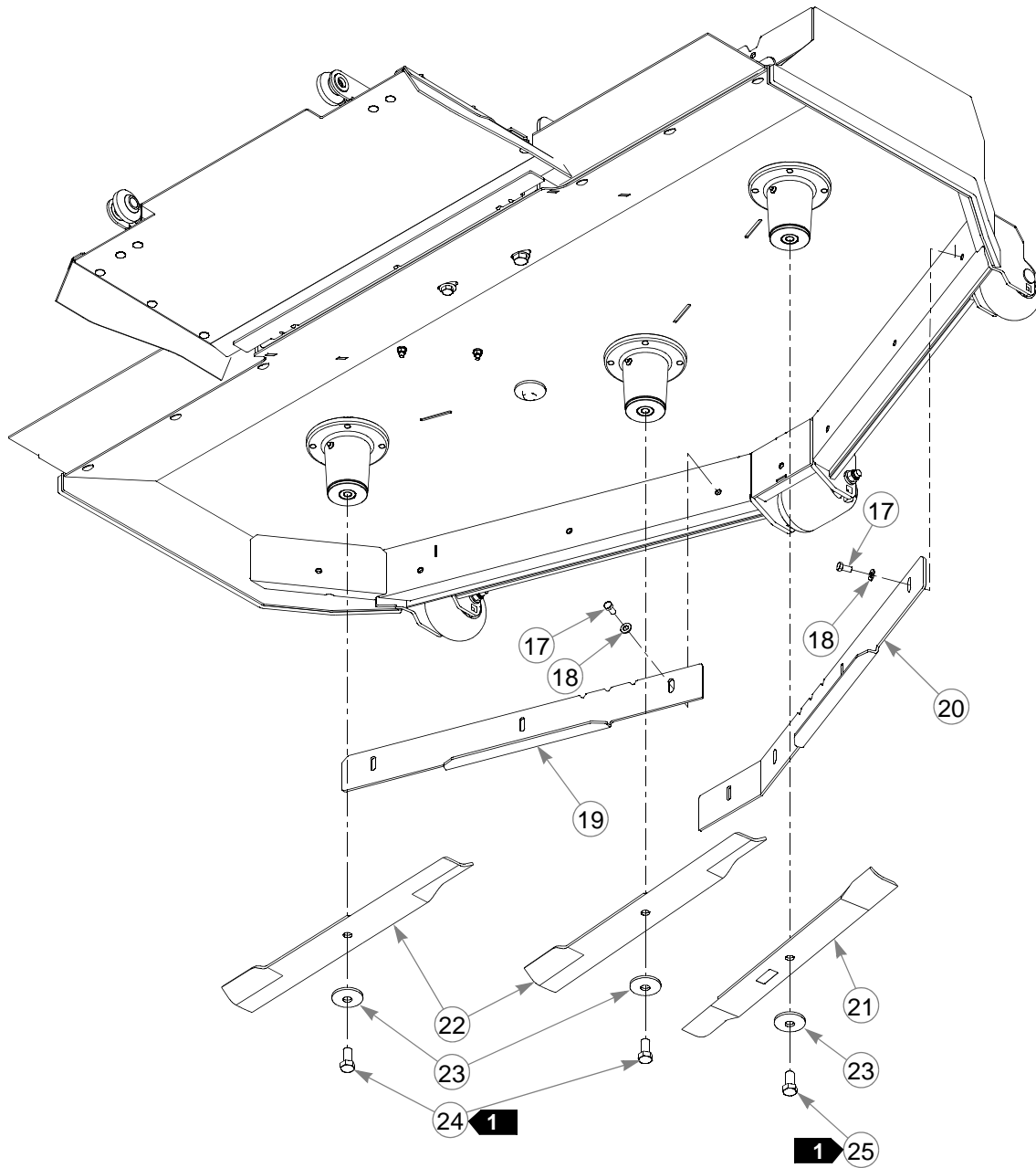

72" Rear Discharge Deck

INDEX NO.	PART NO.	QTY.	DESCRIPTION
17	055822	7	CS .375-16 X .75 HX G5
18	767954	7	FW .379 X .813 X .063
19	114492	1	LS ADJUSTABLE BAFFLE
20	114491	1	RS ADJUSTABLE BAFFLE
21	796508	1	BLADE, F23.86" -L-F-CCW
	601929	1	BLADE, 23.86" GAT-F-CCW
22	796839	2	BLADE, F23.86" -L-F-CW
	794867	2	BLADE, 23.86" -GAT-F-CW
23	782474	3	CW .631 X 2.25 X .187 PNT
24	781872	2	CS .625-11 X 1.25 HX G5 Z
25	604383	1	CS .625-11 X 1.25 HX G5 LH THREAD

NOTES:

1. Torque to 118 ft-lbs.

Deck Lift

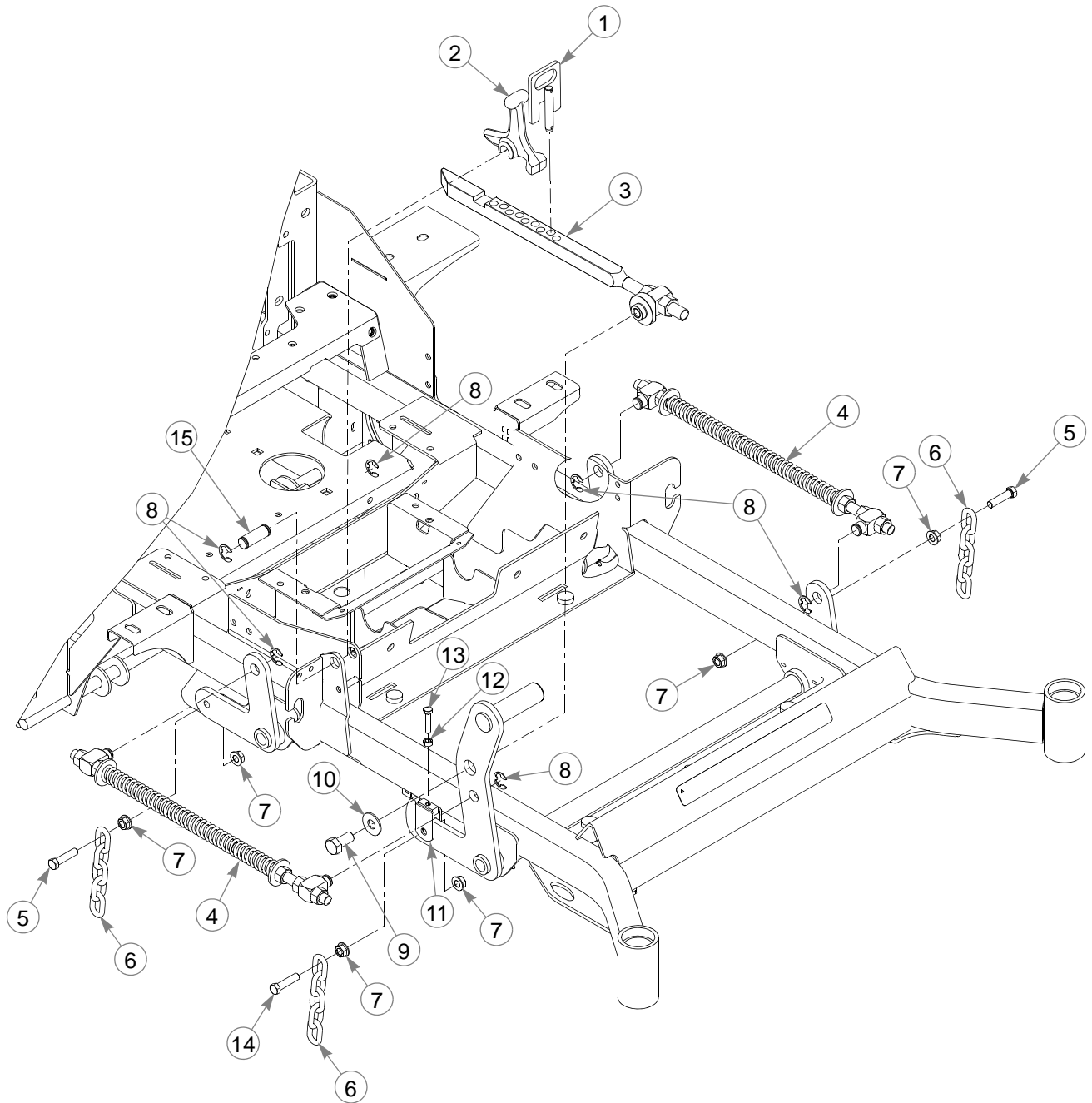

Deck Lift

INDEX NO.	PART NO.	QTY.	DESCRIPTION
1	600437	1	DECK HEIGHT PIN
2	348318	1	STOP HANDLE
3	602898	1	DECK LIFT INDICATOR
4	603184	2	DECK LIFT SPRING
5	055749	7	CS .437-14 X 1.75 HX G5
6	348391	4	DECK LIFT CHAIN
7	704643	16	NT .437-14 HX FLG ZN
8	781294	6	E CLIP 1.00 X .625 X .05
9	781872	1	CS .625-11 X 1.25 HX G5 Z
10	704783	1	FW .625 X 1.50 X .105 ZN
11	348458	1	DECK LEVELER YOKE
12	034272	1	NT .312-18 HX G5
13	756270	1	CS .312-18 X 1.50 HX G5
14	781831	1	CS .437-14 X 1.75 HX G5
15	781229	1	CE .750 X 2.25 X 1.75 HEAD

NOTES:

Deck Mounting Hardware

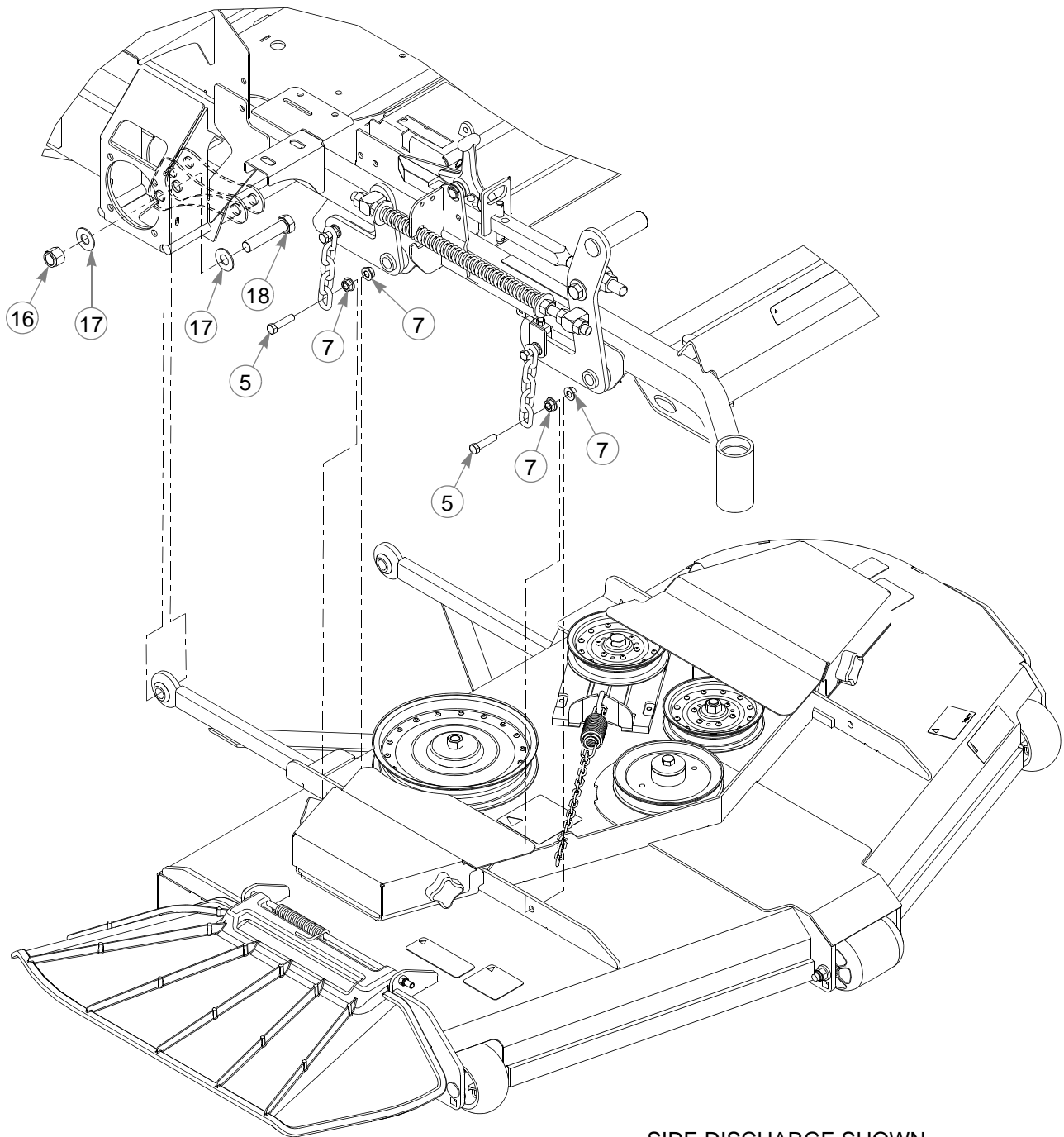

SIDE DISCHARGE SHOWN
REAR DISCHARGE SIMILAR

Deck Mounting Hardware

INDEX NO.	PART NO.	QTY.	DESCRIPTION
16	061101	2	NT .750-10 HX ZY NL
17	025296	4	FW .760 X 1.625 X .08 ZNYC
18	789115	2	CS .750-10 X 3.50 HX G5
19	015495	4	GREASE FITTING, STRAIGHT (NOT SHOWN, REAR DISCHARGE MOWER)

NOTES:

Section 8

Seat, Suspension.	8-2
Seat Service Parts, Suspension	8-4
ROPS.	8-6

Seat, Suspension

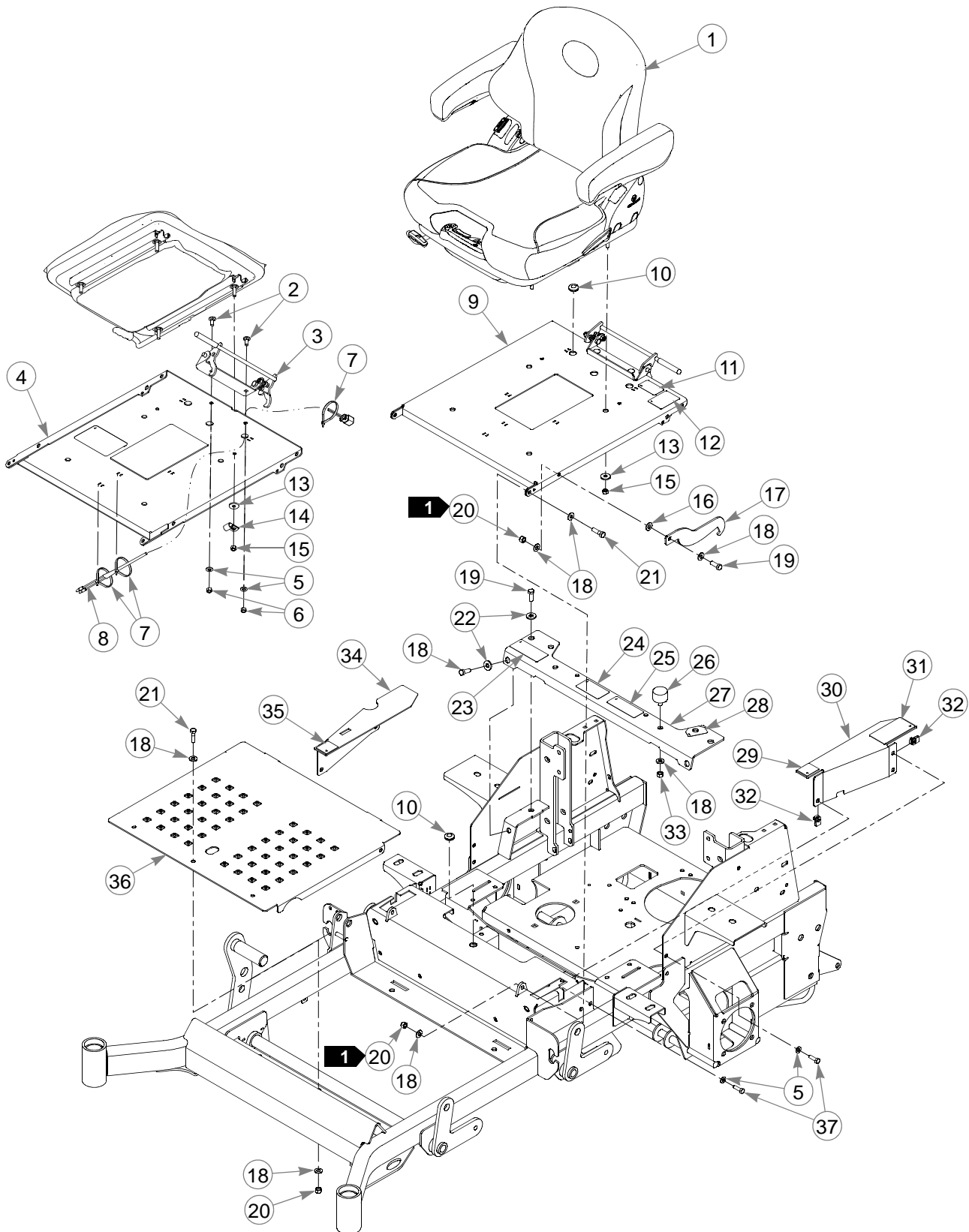

Seat, Suspension

INDEX NO.	PART NO.	QTY.	DESCRIPTION
1	605698	1	SEAT
2	016253	2	CB .312-18 X .75 FUL ZN
3	605907	1	LATCH ASSEMBLY
4	601815	1	BATTERY WARNINGS DECAL
5	768523	7	FW .343 X .687 X .051/.080H
6	034272	2	NT .312-18 HX G5
7	000331	3	WIRE TIE
8	604439	1	SEAT SWITCH PIGTAIL
9	550815	1	SEAT PAN (WITH DECALS & INSTALLATION KIT)
10	080358	2	GM .50 X 1.00 X .75 X .12
11	605688	1	LEVEL FUEL FILL DECAL
12	785188	1	ARMREST WARNING DECAL
13	712927	4	FW .344 X 1.00 X .12 HRD Z
14	000398	1	LOOP CLAMP
15	058776	4	NT .312-18 HX G5 ZY NL
16	724716	2	FIBER WASHER
17	350421	2	SEAT PAN STOP
18	767954	12	FW .379 X .813 X .063
19	036244	6	CS .375-16 X 1.00 HX G5
20	086660	5	NT .375-16 HX G5 NL
21	052860	3	CS .375-16 X 1.25 HX G5
22	712919	4	FW .406 X 1.00 X .12 HRD Z
23	601967	1	ENGINE COMPARTMENT DECAL
24	601968	1	HYDRAULIC PRESSURE DECAL
25	779280	1	HOT & HYD OIL DECAL
26	601650	2	VIBRATION MOUNT
27	550816	1	SEAT SUPPORT (WITH DECALS)
28	791848	1	FUEL INDICATOR DECAL
29	785139	1	LS STEERING DECAL
30	550823	1	LS FRAME COVER (WITH DECALS)
31	600899	1	PUMP BELT WARNING DECAL
32	601069	5	CN .312-18 X .20 MAX THK
33	054502	2	NT .375-16 HX G5
34	550824	1	RS FRAME COVER (WITH DECAL)
35	785220	1	RS STEERING DECAL
36	117323	1	FLOOR PAN
37	036236	5	CS .312-18 X 1.00 HX G5

NOTES:

1. Do not torque; the seat pan and seat pan stop must pivot freely.

Seat Service Parts, Suspension



INDEX NO.	PART NO.	QTY.	DESCRIPTION
1	605750	1	BACK CUSHION
2	604938	1	RS ARMREST
3	604937	1	LS ARMREST
4	604941	1	SEAT BELT
5	605752	1	SEAT CUSHION
6	119287	1	SLIDE KIT
7	604973	1	SEAT SWITCH (NOT SHOWN)

NOTES:

This page intentionally left blank.

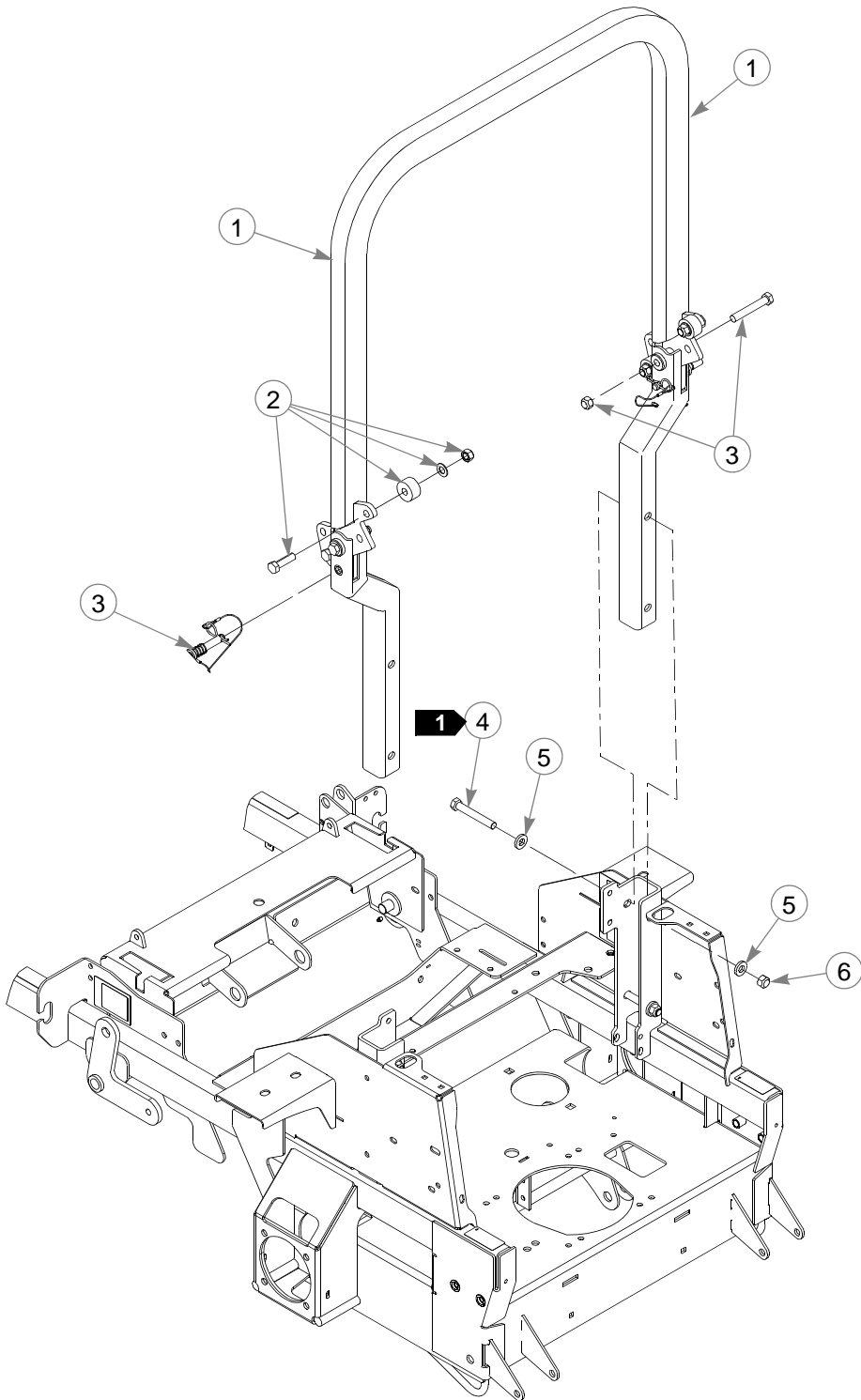

ROPS

INDEX NO.	PART NO.	QTY.	DESCRIPTION
1	605639	1	ROPS KIT
2	605731	2	POLY STOP KIT
3	605638	1	ROPS HARDWARE KIT
4	061812	4	CS .500-13 X 3.50 HX G5
5	767962	8	FW .531 X 1.063 X .175
6	023317	4	NT .500-13 UNT LK G8 ZN

NOTES:

1. Torque to 73 ft-lbs.

