



**MANITOU NORTH AMERICA, INC.**

6401 IMPERIAL DRIVE  
Waco, TX 76712-6803

**NOTE:** *Manitou Forklift Manuals are continually updated and subject to change without prior notice. If your Forklift Model or parts are not found in this manual, please contact your dealer or the Manitou North America Parts Department for the latest information and parts availability.*

**MSI30 D  
MH25-4 Turbo  
Series 2-E3**

S/N: 254496 & above

**PARTS MANUAL**

For Parts Orders contact your Manitou North America Dealer or call:  
**Manitou North America, Parts Dept.** 800-425-3727 or (254) 799-0232  
Parts Dept. Fax: (254) 867-6504 Website: [www.manitou-na.com](http://www.manitou-na.com)





BP 249 Z.I.  
44 158 ANCENIS CEDEX FRANCE  
TEL : 02 40 09 10 11

REF : CD 647000

MSI 20 T Série 2-E3 - MSI 20 T BUGGIE Série 2-E3  
MSI 25 T Série 2-E3 - MSI 25 T BUGGIE Série 2-E3  
MSI 30 T Série 2-E3 - MSI 30 T BUGGIE Série 2-E3  
MSI 35 T Série 2-E3 - MSI 35 T BUGGIE Série 2-E3

MH 20-4 Turbo BUGGIE Série 2-E3  
MH 25-4 Turbo BUGGIE Série 2-E3

A PARTIR DE LA MACHINE  
AB DER MASCHINE  
A PARTIR DE LA MAQUINA  
FROM MACHINE  
A PARTIR DA MACCHINA

↳ N° : 254 496

CATALOGUE PIECES  
ERSATZTEILKATALOG  
CATALOGO DE PIEZAS  
PARTS CATALOGUE  
CATALOGO RICAMBI

1ère DATE D'EDITION - 1st DATUM AUSGABE  
1ra FECHA EDICION - 1st DATE PUBLICATION  
1a DATA DI PUBBLICAZIONE

05 / 2008

INFORMATION CATALOGUE KATALOG AUSKUNFT INFORMACION CATALOGO CATALOGUE INFORMATION INFORMAZIONI CATALOGO	DATE D'EDITION DATUM AUSGABE FECHA EDICION DATE PUBLICATION DATA DI PUBBLICAZIONE	OBSERVATION BEMERKUNG OBSERVACION OBSERVATION OSSERVAZIONI
IC 543	00 / 2007	1ère EDITION - 1st AUSGABE 1ra EDICION - 1st PUBLICATION 1a EDIZIONE

# CATALOGUE PIÈCES INTERACTIF

I  
N  
D  
E  
X

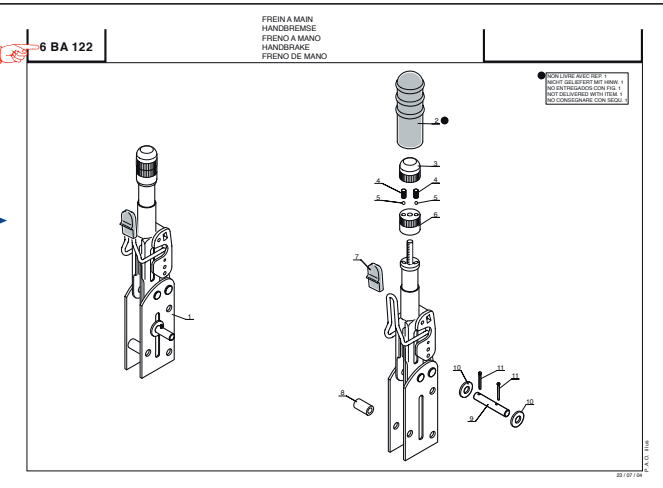
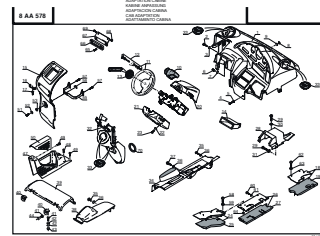
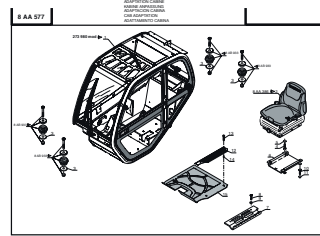
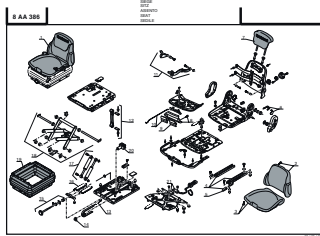
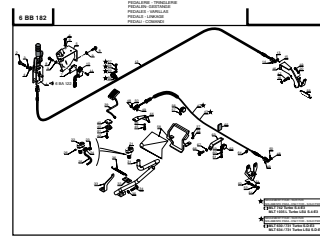
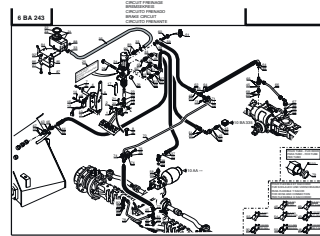
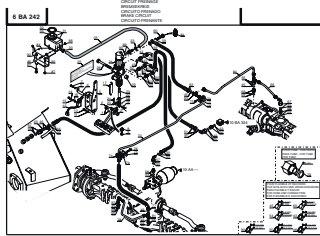
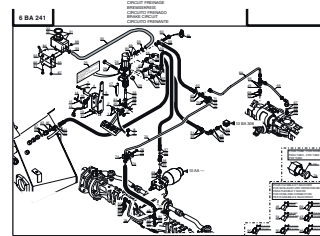
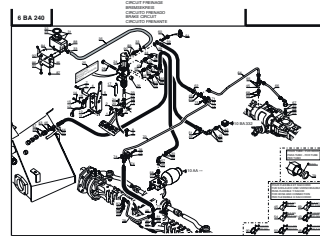
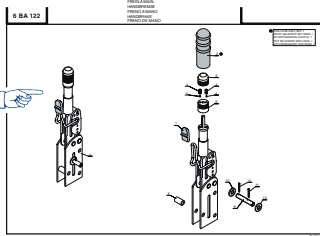

ALLER  
RETOUR

## IMPORTANT

### PARTS LISTS :

The text pages have a figure (for example : 1) printed in the top left corner, and a sign at the bottom (+).

- «1» means that this is the first page of text.
- «+» means that the parts list is not finished, and that there are more pages. The last page does not have the «+» sign.
- «X» in the Quantity columns means = according to need.

### PARTS ORDER :

When placing an order, always state :

- Spare part ref. number
- Complete description
- Quantity
- Type of machine
- Machine serial number.
- Component identification number  
(mast, jib, cab, engine, etc)

### CAUTION :

Certain parts, or part assemblies illustrated in this catalogue are only supplied as options, and not with the standard machine.

### SYMBOLS :

└─▶ : From (machine, engine, date, etc.)  
─▶ : Up to (machine, engine, date, etc.)

□□ : For (machine, engine, date, etc.)  
□□ : Except for (machine, engine, date, etc.)  
◀ : See drawing

●, ■, ▲, ★, ⊕, ⊙, ⊕ : Up to } machine N°,  
○, □, △, ☆, ⊗, ⊙, ⊕ : From } N° engine, cab,  
transmission, etc.

## IMPORTANTE

### NOMENCLATURA :

Le pagine di testo hanno in alto a sinistra, una cifra, esempio : 1 e in basso un segno +.

- L' «1» significa che si tratta della prima pagina di testo.
- Il «+» indica che la nomenclatura non è terminata e che esistono altre pagine a seguire, l'ultima pagina è senza il segno +.
- Il segno «X» nelle colonne Qtà = secondo il bisogno.

### ORDINE DI PEZZI :

Per passare i vostri ordini, precisare sempre :

- N° pezzo di ricambio
- Descrizione completa
- Quantità
- Tipo di macchina
- N° di serie della macchina
- N° d'identificazione componente  
(rampa, braccio, cabina, motore, ecc.)

### ATTENZIONE :

Alcuni pezzi o montaggio di pezzi illustrati in questo catalogo vengono spediti solamente come optional e non con la macchina standard.

### SIMBOLI :

└─▶ : A partire da (macchina, motore, data, ecc.)  
─▶ : Fino a ( macchina, motore, data, ecc.)

□□ : Per (macchina, motore, ecc.)  
□□ : Escluso per (macchina, motore, ecc.)  
◀ : Vedere tavola

●, ■, ▲, ★, ⊕, ⊙, ⊕ : Fino a } macchina N°,  
○, □, △, ☆, ⊗, ⊙, ⊕ : A partire da } N° motore, cabina,  
trasmissione, ecc.

**2 AA 188**

FILTRES ET COURROIES  
 FILTER UND KEILRIEMEN  
 FILTROS Y CORREAS  
 FILTERS AND BELTS  
 FILTROS E CINGHIA

MH 20-4 T BUGGIE S2-E3  
 MH 25-4 T BUGGIE S2-E3  
 MSI 20 / 25 / 30 / 35 T S2-E3  
 MSI 20 / 25 / 30 / 35 T BUGGIE S2-E3

1. FILTRE A CARBONE  
 CARBON FILTER  
 FILTRO DE CARBÓN  
 CARBON FILTER  
 FILTRO DE CARBÓN

2. FILTRE A PAPIER  
 PAPER FILTER  
 FILTRO DE PAPEL  
 PAPER FILTER  
 FILTRO DE PAPEL

3. FILTRE A PAPIER  
 PAPER FILTER  
 FILTRO DE PAPEL  
 PAPER FILTER  
 FILTRO DE PAPEL

4. FILTRE A PAPIER  
 PAPER FILTER  
 FILTRO DE PAPEL  
 PAPER FILTER  
 FILTRO DE PAPEL

5. FILTRE A PAPIER  
 PAPER FILTER  
 FILTRO DE PAPEL  
 PAPER FILTER  
 FILTRO DE PAPEL

6. COURROIE DE TRANSMISSION  
 TRANSMISSION BELT  
 CINGHIA DI TRASMISSIONE  
 TRANSMISSION BELT  
 CINGHIA DI TRASMISSIONE

7. COURROIE DE TRANSMISSION  
 TRANSMISSION BELT  
 CINGHIA DI TRASMISSIONE  
 TRANSMISSION BELT  
 CINGHIA DI TRASMISSIONE

8. COURROIE DE TRANSMISSION  
 TRANSMISSION BELT  
 CINGHIA DI TRASMISSIONE  
 TRANSMISSION BELT  
 CINGHIA DI TRASMISSIONE

pg. 19

**3 AA 293**

ROUES  
 RAD  
 RUEDAS  
 WHEELS  
 RUOTE

MSI 20 / 25 / 30 / 35 T S2-E3  
 MSI 20 / 25 / 30 / 35 T BUGGIE S2-E3

GOOD YEAR  
 275/70 R22.5 TRMS 14R1145 M

CONTINENTAL  
 700x12 14PR IC40

pg. 21

**3 AA 294**

ROUES  
 RAD  
 RUEDAS  
 WHEELS  
 RUOTE

MH 20-4 T BUGGIE S2-E3  
 MH 25-4 T BUGGIE S2-E3

MICHELIN  
 280/80 R22 XACL 133A8

CONTINENTAL  
 27.10.12 14PR IC30

pg. 25

**4 AA 747**

ADAPTATION MOTEUR-TRANSMISSION  
 MOTOR-GETRIEBE ANPASSUNG  
 ADAPTACION MOTOR-TRANSMISION  
 ENGINE-TRANSMISSION ADAPTATION  
 ADATTAMENTO MOTORE - TRASMISSIONE

MH 20-4 T BUGGIE S2-E3  
 MH 25-4 T BUGGIE S2-E3  
 MSI 20 / 25 / 30 / 35 T S2-E3  
 MSI 20 / 25 / 30 / 35 T BUGGIE S2-E3

pg. 29

**4 AA 748**

ADAPTATION MOTEUR-TRANSMISSION  
 MOTOR-GETRIEBE ANPASSUNG  
 ADAPTACION MOTOR-TRANSMISION  
 ENGINE-TRANSMISSION ADAPTATION  
 ADATTAMENTO MOTORE - TRASMISSIONE

MH 20-4 T BUGGIE S2-E3  
 MH 25-4 T BUGGIE S2-E3  
 MSI 20 / 25 / 30 / 35 T S2-E3  
 MSI 20 / 25 / 30 / 35 T BUGGIE S2-E3

pg. 33

**4 AA 749**

ADAPTATION MOTEUR-TRANSMISSION  
 MOTOR-GETRIEBE ANPASSUNG  
 ADAPTACION MOTOR-TRANSMISION  
 ENGINE-TRANSMISSION ADAPTATION  
 ADATTAMENTO MOTORE - TRASMISSIONE

MH 20-4 T BUGGIE S2-E3  
 MH 25-4 T BUGGIE S2-E3  
 MSI 20 / 25 / 30 / 35 T S2-E3  
 MSI 20 / 25 / 30 / 35 T BUGGIE S2-E3

pg. 37

**4 AA 750**

ADAPTATION MOTEUR-TRANSMISSION  
 MOTOR-GETRIEBE ANPASSUNG  
 ADAPTACION MOTOR-TRANSMISION  
 ENGINE-TRANSMISSION ADAPTATION  
 ADATTAMENTO MOTORE - TRASMISSIONE

MH 20-4 T BUGGIE S2-E3  
 MH 25-4 T BUGGIE S2-E3  
 MSI 20 / 25 / 30 / 35 T S2-E3  
 MSI 20 / 25 / 30 / 35 T BUGGIE S2-E3

pg. 41

**4 AB 182**

CIRCUIT TRANSMISSION HYDROSTATIQUE  
 HYDROSTATIK GETRIEBESCHWELB  
 CIRCUITO TRANSMISION HIDROSTATICO  
 HYDROSTATIC TRANSMISSION CIRCUIT  
 CIRCUITO TRASMISSIONE IDROSTATICO

MSI 20 / 25 / 30 / 35 T S2-E3  
 MSI 20 / 25 / 30 / 35 T BUGGIE S2-E3

pg. 45

**4 AB 183**

CIRCUIT TRANSMISSION HYDROSTATIQUE  
 HYDROSTATIK GETRIEBESCHWELB  
 CIRCUITO TRANSMISION HIDROSTATICO  
 HYDROSTATIC TRANSMISSION CIRCUIT  
 CIRCUITO TRASMISSIONE IDROSTATICO

MSI 20 / 25 / 30 / 35 T S2-E3  
 MSI 20 / 25 / 30 / 35 T BUGGIE S2-E3

pg. 53



**4 AB 184**

CIRCUIT TRANSMISSION HYDROSTATIQUE  
HYDROSTATIK GETRIEBKREIS  
CIRCUITO TRANSMISSIONE IDROSTATICO  
CIRCUITO TRANSMISSIONE IDROSTATICO

MH 20-4 T BUGGIE S2-E3  
MH 25-4 T BUGGIE S2-E3

POUR FLEXIBLE ET RACCORDS  
FÜR SCHLAUCHE UND VERBINDER  
PARA FLEXIBLE Y RACOR  
FOR HOSE AND CONNECTION  
VEN FLESSIBILE E RACCORDI

**pg. 59**

**4 AB 185**

CIRCUIT TRANSMISSION HYDROSTATIQUE  
HYDROSTATIK GETRIEBKREIS  
CIRCUITO TRANSMISSIONE IDROSTATICO  
CIRCUITO TRANSMISSIONE IDROSTATICO

MH 20-4 T BUGGIE S2-E3  
MH 25-4 T BUGGIE S2-E3

POUR FLEXIBLE ET RACCORDS  
FÜR SCHLAUCHE UND VERBINDER  
PARA FLEXIBLE Y RACOR  
FOR HOSE AND CONNECTION  
VEN FLESSIBILE E RACCORDI

**pg. 67**

**4 AB 186**

CIRCUIT TRANSMISSION HYDROSTATIQUE  
HYDROSTATIK GETRIEBKREIS  
CIRCUITO TRANSMISSIONE IDROSTATICO  
CIRCUITO TRANSMISSIONE IDROSTATICO

MH 20-4 T BUGGIE S2-E3  
MH 25-4 T BUGGIE S2-E3

POUR FLEXIBLE ET RACCORDS  
FÜR SCHLAUCHE UND VERBINDER  
PARA FLEXIBLE Y RACOR  
FOR HOSE AND CONNECTION  
VEN FLESSIBILE E RACCORDI

POUR TUBE POUR TUBES  
FÜR RÖHRE FÜR RÖHREN  
PARA TUBO PARA TUBOS

**pg. 75**

**4 AC 266**

CIRCUIT COMBUSTIBLE  
BRENNSYSTEMKREIS  
CIRCUITO COMBUSTIBILE  
FUEL CIRCUIT  
SISTEMA NAFTA

MH 20-4 T BUGGIE S2-E3  
MH 25-4 T BUGGIE S2-E3  
MSI 20 / 25 / 30 / 35 T BUGGIE S2-E3

**pg. 81**

**6 AA 421**

CHASSIS - CONTREPOIDS  
GESTELL - GEGENGEWICHT  
BASTIDOR - CONTRAPESO  
FRAME - COUNTERWEIGHT  
TELAIO - CONTRAPPESO

MH 20-4 T BUGGIE S2-E3  
MH 25-4 T BUGGIE S2-E3  
MSI 20 / 25 / 30 / 35 T BUGGIE S2-E3

**pg. 89**

**6 BB 188**

PEDALERIE - TRINGLERIE  
PEDALES - TRINGLERIE  
PEDALES - VARILLAS  
PEDALS - LINKAGE  
PEDALI - COMANDI

MH 20-4 T BUGGIE S2-E3  
MH 25-4 T BUGGIE S2-E3  
MSI 20 / 25 / 30 / 35 T BUGGIE S2-E3

**pg. 93**

**7 AA 47**

ESSIEU ARRIERE  
HINTERACHSE  
EJE TRASERO  
REAR AXLE  
PONTE POSTERIORE

MH 20-4 T BUGGIE S2-E3  
MH 25-4 T BUGGIE S2-E3

**pg. 101**

**7 AA 74**

ESSIEU ARRIERE  
HINTERACHSE  
EJE TRASERO  
REAR AXLE  
PONTE POSTERIORE

MSI 20 / 25 / 30 / 35 T S2-E3  
MSI 20 / 25 / 30 / 35 T BUGGIE S2-E3

**pg. 105**

**8 AA 390**

SIEGE (Skai)  
SITZ (synthetisch abtft)  
ASIENTO (Tapajo sinttico)  
SEAT (Synthetisch wovnen)  
SEDLICE (Skv)

MH 20-4 T BUGGIE S2-E3  
MH 25-4 T BUGGIE S2-E3  
MSI 20 / 25 / 30 / 35 T S2-E3  
MSI 20 / 25 / 30 / 35 T BUGGIE S2-E3

**pg. 111**



<b>8 AA 604</b>	ADAPTATION SIEGE SITZ ANPASSUNG ADAPTACION ASIENTO SEAT ADAPTATION ADATTAMENTO SEDEILE	MH 20-4 T BUGGIE S2-E3 MH 25-4 T BUGGIE S2-E3 MSI 20 / 25 / 30 / 35 T S2-E3 MSI 20 / 25 / 30 / 35 T BUGGIE S2-E3	
<b>pg.115</b>			

<b>8 AA 605</b>	ADAPTATION CABINE KABINE ANPASSUNG ADAPTACION CABINA CAB ADAPTATION ADATTAMENTO CABINA	MH 20-4 T BUGGIE S2-E3 MH 25-4 T BUGGIE S2-E3 MSI 20 / 25 / 30 / 35 T S2-E3 MSI 20 / 25 / 30 / 35 T BUGGIE S2-E3	
<b>pg.117</b>			

<b>8 AA 606</b>	ADAPTATION CABINE KABINE ANPASSUNG ADAPTACION CABINA CAB ADAPTATION ADATTAMENTO CABINA	MH 20-4 T BUGGIE S2-E3 MH 25-4 T BUGGIE S2-E3 MSI 20 / 25 / 30 / 35 T S2-E3 MSI 20 / 25 / 30 / 35 T BUGGIE S2-E3	
<b>pg.123</b>			

<b>8 AA 607</b>	GARDE-BOUE KÜHLESPRITZBLECH GUARDADARRIOS SPLASH APRON PARRANCO	MH 20-4 T BUGGIE S2-E3 MH 25-4 T BUGGIE S2-E3	
<b>pg.129</b>			

<b>8 AB 906</b>	PROTEGE CONDUCTEUR (Détails) FÜHRER SCHUTZVORRICHTUNG (Einzelteile) PROTECTOR CONDUCTOR (Details) DRIVER'S OVERHEAD GUARD (Details) PROTEZIONE CONDUCENTE (Dettaglio)	MSI 20 / 25 / 30 / 35 T S2-E3	
<b>pg.133</b>			

<b>8 AB 907</b>	PROTEGE CONDUCTEUR (Détails) FÜHRER SCHUTZVORRICHTUNG (Einzelteile) PROTECTOR CONDUCTOR (Details) DRIVER'S OVERHEAD GUARD (Details) PROTEZIONE CONDUCENTE (Dettaglio)	MSI 20 / 25 / 30 / 35 T S2-E3	
<b>pg.137</b>			

<b>8 AB 908</b>	PROTEGE CONDUCTEUR (Détails) FÜHRER SCHUTZVORRICHTUNG (Einzelteile) PROTECTOR CONDUCTOR (Details) DRIVER'S OVERHEAD GUARD (Details) PROTEZIONE CONDUCENTE (Dettaglio)	MSI 20 / 25 / 30 / 35 T S2-E3	
<b>pg.143</b>			

<b>8 AB 909</b>	PROTEGE CONDUCTEUR (Détails) FÜHRER SCHUTZVORRICHTUNG (Einzelteile) PROTECTOR CONDUCTOR (Details) DRIVER'S OVERHEAD GUARD (Details) PROTEZIONE CONDUCENTE (Dettaglio)	MSI 20 / 25 / 30 / 35 T S2-E3	
<b>pg.147</b>			

<b>8 AB 910</b>	PROTEGE CONDUCTEUR (Détails) FÜHRER SCHUTZVORRICHTUNG (Einzelteile) PROTECTOR CONDUCTOR (Details) DRIVER'S OVERHEAD GUARD (Details) PROTEZIONE CONDUCENTE (Dettaglio)	MH 20-4 T BUGGIE S2-E3 MH 25-4 T BUGGIE S2-E3 MSI 20 / 25 / 30 / 35 T S2-E3 MSI 20 / 25 / 30 / 35 T BUGGIE S2-E3	
<b>pg.151</b>			





<b>8 AB 911</b>	POR TIPO DE PROTECTOR CONDUCTEUR FÜR FÜHRER SCHUTZVORRICHTUNG (Einzelteile) PARA TIPO DE PROTECTOR CONDUCTOR CON PARTES DE SOBRECARGA GUARD TYPE C1384 911	PROTEGE CONDUCTEUR (Détails) FÜHRER SCHUTZVORRICHTUNG (Einzelteile) PROTECTOR CONDUCTOR (Details) DRIVER'S OVERHEAD GUARD (Details) PROTEZIONE CONDUCENTE (Dettaglio)	MH 20-4 T BUGGIE S2-E3 MH 25-4 T BUGGIE S2-E3 MSI 20 / 25 / 30 / 35 T BUGGIE S2-E3
-----------------	--	---	--

**pg.155**

<b>8 AB 912</b>	POR TIPO DE PROTECTOR CONDUCTEUR FÜR FÜHRER SCHUTZVORRICHTUNG (Einzelteile) PARA TIPO DE PROTECTOR CONDUCTOR CON PARTES DE SOBRECARGA GUARD TYPE C1384 911	PROTEGE CONDUCTEUR (Détails) FÜHRER SCHUTZVORRICHTUNG (Einzelteile) PROTECTOR CONDUCTOR (Details) DRIVER'S OVERHEAD GUARD (Details) PROTEZIONE CONDUCENTE (Dettaglio)	MH 20-4 T BUGGIE S2-E3 MH 25-4 T BUGGIE S2-E3 MSI 20 / 25 / 30 / 35 T BUGGIE S2-E3
-----------------	--	---	--

**pg.161**

<b>8 AB 913</b>	POR TIPO DE PROTECTOR CONDUCTEUR FÜR FÜHRER SCHUTZVORRICHTUNG (Einzelteile) PARA TIPO DE PROTECTOR CONDUCTOR CON PARTES DE SOBRECARGA GUARD TYPE C1384 911	PROTEGE CONDUCTEUR (Détails) FÜHRER SCHUTZVORRICHTUNG (Einzelteile) PROTECTOR CONDUCTOR (Details) DRIVER'S OVERHEAD GUARD (Details) PROTEZIONE CONDUCENTE (Dettaglio)	MH 20-4 T BUGGIE S2-E3 MH 25-4 T BUGGIE S2-E3 MSI 20 / 25 / 30 / 35 T BUGGIE S2-E3
-----------------	--	---	--

**pg.165**

<b>9 AB 103</b>	INSONORISATION SCHALLDÄMMUNG INSORRIZACION SOUND-PROOFING INSONORIZZAZIONE	MH 20-4 T BUGGIE S2-E3 MH 25-4 T BUGGIE S2-E3 MSI 20 / 25 / 30 / 35 T S2-E3 MSI 20 / 25 / 30 / 35 T BUGGIE S2-E3
-----------------	--	---

**pg.169**

<b>10 AA 741</b>	HYDRAULIQUE (Circuit principal) HYDRAULIK (Hauptkreis) HIDRAULICO (Circuito principal) IDRAULICO (Principal circuit) IDRAULICO (Circuito principale)	MH 20-4 T BUGGIE S2-E3 MH 25-4 T BUGGIE S2-E3 MSI 20 / 25 / 30 / 35 T S2-E3 MSI 20 / 25 / 30 / 35 T BUGGIE S2-E3
------------------	--	---

**pg.173**

<b>10 AA 742</b>	HYDRAULIQUE (Circuit principal) HYDRAULIK (Hauptkreis) HIDRAULICO (Circuito principal) IDRAULICO (Principal circuit) IDRAULICO (Circuito principale)	MSI 30 / 35 T S2-E3 MSI 20 / 25 / 30 / 35 T BUGGIE S2-E3
------------------	--	---

**pg.181**

<b>10 AB 63</b>	HYDRAULIQUE (Circuit inclination - Elevation) HYDRAULIK (Neigung - Aufenden Kreis) HIDRAULICO (Circuito inclinación - Elevación) HYDRAULIC (Tilting - Lifting circuit) IDRAULICO (Circuito inclinazione - Sollevamento)	MH 20-4 T BUGGIE S2-E3 MH 25-4 T BUGGIE S2-E3 MSI 20 / 25 / 30 / 35 T S2-E3 MSI 20 / 25 / 30 / 35 T BUGGIE S2-E3
-----------------	---	---

**pg.189**

<b>10 AB 64</b>	HYDRAULIQUE (Circuit inclination - Elevation) HYDRAULIK (Neigung - Aufenden Kreis) HIDRAULICO (Circuito inclinación - Elevación) HYDRAULIC (Tilting - Lifting circuit) IDRAULICO (Circuito inclinazione - Sollevamento)	MH 20-4 T BUGGIE S2-E3 MH 25-4 T BUGGIE S2-E3 MSI 20 / 25 / 30 / 35 T S2-E3 MSI 20 / 25 / 30 / 35 T BUGGIE S2-E3
-----------------	---	---

**pg.195**

<b>10 AJ 12</b>	HYDRAULIQUE (Circuit levage cabine) HYDRAULIK (Kabine aufenden Kreis) HIDRAULICO (Circuito levantamiento cabina) HYDRAULIC (Cab lifting circuit) IDRAULICO (Circuito sollevamento cabina)	MH 20-4 T BUGGIE S2-E3 MH 25-4 T BUGGIE S2-E3 MSI 20 / 25 / 30 / 35 T S2-E3 MSI 20 / 25 / 30 / 35 T BUGGIE S2-E3
-----------------	---	---

**pg.201**



**10 BA 342**

HYDRAULIQUE (Circuit direction)  
HYDRAULIK (Lenkungsstrom) / HYDRAULICO (Circuito direzione)  
HYDRAULIC (Steering circuit)  
IDRAULICO (Circuito sterzo)

MH 20-4 T BUGGIE S2-E3  
MH 25-4 T BUGGIE S2-E3  
MSI 20 / 25 / 30 / 35 T S2-E3  
MSI 20 / 25 / 30 / 35 T BUGGIE S2-E3

pg.207

**10 CD 32**

HYDRAULIQUE (Vérin d'inclinaison) (Inclinaison 10°/12°)  
HYDRAULIK (Neigungszylinder) (Neigung 10°/12°)  
HYDRAULICO (Cilindro di inclinazione) (Inclinazione 10°/12°)  
HYDRAULIC (Tilting cylinder) (Tilting 10°/12°)  
IDRAULICO (Cilindro di inclinazione) (Inclinazione 10°/12°)

MH 20-4 T BUGGIE S2-E3  
MH 25-4 T BUGGIE S2-E3  
MSI 20 / 25 / 30 / 35 T S2-E3  
MSI 20 / 25 / 30 / 35 T BUGGIE S2-E3

pg.213

**10 CD 33**

HYDRAULIQUE (Vérin d'inclinaison) (Inclinaison 6°/8°)  
HYDRAULIK (Neigungszylinder) (Neigung 6°/8°)  
HYDRAULICO (Cilindro di inclinazione) (Inclinazione 6°/8°)  
HYDRAULIC (Tilting cylinder) (Tilting 6°/8°)  
IDRAULICO (Cilindro di inclinazione) (Inclinazione 6°/8°)

MH 20-4 T BUGGIE S2-E3  
MH 25-4 T BUGGIE S2-E3  
MSI 20 / 25 / 30 / 35 T S2-E3  
MSI 20 / 25 / 30 / 35 T BUGGIE S2-E3

pg.217

**10 CE 32**

HYDRAULIQUE (Vérin de direction)  
HYDRAULIK (Lenkungszyylinder)  
HYDRAULICO (Cilindro di direzione)  
HYDRAULIC (Steering cylinder)  
IDRAULICO (Cilindro di sterzo)

MH 20-4 T BUGGIE S2-E3  
MH 25-4 T BUGGIE S2-E3

pg.221

**10 CE 33**

HYDRAULIQUE (Vérin de direction)  
HYDRAULIK (Lenkungszyylinder)  
HYDRAULICO (Cilindro di direzione)  
HYDRAULIC (Steering cylinder)  
IDRAULICO (Cilindro di sterzo)

MSI 20 / 25 / 30 / 35 T S2-E3  
MSI 20 / 25 / 30 / 35 T S2-E3

pg.225

**10 DA 92**

DISTRIBUTEUR  
KOMMANDOSTEUERVENTIL  
DISTRIBUTOR  
VALVE BANK  
DISTRIBUTORE

MH 20-4 T BUGGIE S2-E3  
MH 25-4 T BUGGIE S2-E3  
MSI 20 / 25 / 30 / 35 T S2-E3  
MSI 20 / 25 / 30 / 35 T BUGGIE S2-E3

pg.229

**10 EA 224**

HYDRAULIQUE (Détails)  
HYDRAULIK (Einzelteile)  
HYDRAULICO (Dettagli)  
HYDRAULIC (Details)  
IDRAULICO (Particolari)

MH 20-4 T BUGGIE S2-E3  
MH 25-4 T BUGGIE S2-E3  
MSI 20 / 25 / 30 / 35 T S2-E3  
MSI 20 / 25 / 30 / 35 T BUGGIE S2-E3

pg.233

**11 AA 1283**

CIRCUIT ELECTRIQUE  
STROMKREIS  
CIRCUITO ELETTRICO  
ELECTRIC CIRCUIT  
IMPIANTO ELETTRICO

MSI 20 / 25 / 30 / 35 T S2-E3  
MSI 20 / 25 / 30 / 35 T S2-E3

pg.237

**11 AA 1284**

CIRCUIT ELECTRIQUE  
STROMKREIS  
CIRCUITO ELETTRICO  
ELECTRIC CIRCUIT  
IMPIANTO ELETTRICO

MSI 20 / 25 / 30 / 35 T S2-E3  
MSI 20 / 25 / 30 / 35 T S2-E3

pg.243



**11 AA 1285**

CIRCUIT ELECTRIQUE  
STROMKREIS  
CIRCUITO ELECTRICO  
ELECTRIC CIRCUIT  
IMPIANTO ELETTRICO

MH 20-4 T BUGGIE S2-E3  
MH 25-4 T BUGGIE S2-E3

pg.247

**11 AA 1286**

CIRCUIT ELECTRIQUE  
STROMKREIS  
CIRCUITO ELECTRICO  
ELECTRIC CIRCUIT  
IMPIANTO ELETTRICO

MH 20-4 T BUGGIE S2-E3  
MH 25-4 T BUGGIE S2-E3

pg.255

**11 CB 885**

ELECTRICITE (Details)  
ELEKTROFAT (Einzelheiten)  
ELECTRICIDAD (Detalles)  
ELECTRICITY (Details)  
ELETTRICO (Dettaglio)

MH 20-4 T BUGGIE S2-E3  
MH 25-4 T BUGGIE S2-E3  
MSI 20 / 25 / 30 / 35 T S2-E3  
MSI 20 / 25 / 30 / 35 T BUGGIE S2-E3

pg.259

**11 CC 218**

ELECTRICITE (Poste de conduite)  
ELEKTROFAT (Fahrerstand)  
ELECTRICIDAD (Puesto del conductor)  
ELECTRICITY (Cab structure)  
ELETTRICO (Posto di pilotaggio)

MH 20-4 T BUGGIE S2-E3  
MH 25-4 T BUGGIE S2-E3  
MSI 20 / 25 / 30 / 35 T S2-E3  
MSI 20 / 25 / 30 / 35 T BUGGIE S2-E3

pg.265

**11 CD 156**

ELECTRICITE (Moteur - Transmission)  
ELEKTROFAT (Motor - Getriebe)  
ELECTRICIDAD (Motor - Transmision)  
ELECTRICITY (Engine - Transmission)  
ELETTRICO (Motore - Transmissions)

MH 20-4 T BUGGIE S2-E3  
MH 25-4 T BUGGIE S2-E3  
MSI 20 / 25 / 30 / 35 T S2-E3  
MSI 20 / 25 / 30 / 35 T BUGGIE S2-E3

pg.273

**12 AA 524**

ADHESIFS  
KLEBSTOFF  
ADHESIVO  
ADHESIVE  
ADESIVO

MH 20-4 T BUGGIE S2-E3  
MH 25-4 T BUGGIE S2-E3  
MSI 20 / 25 / 30 / 35 T S2-E3  
MSI 20 / 25 / 30 / 35 T BUGGIE S2-E3

MANITOU

MSI20T  
MSI25T  
MSI30T  
MSI35T  
MH20-4T  
MH25-4T

MANITOU  
BUGGIE

pg.275



## MOTEUR - MOTOR

## MOTOR - ENGINE

## MOTORE

TYPE - TYPEN

TIPO - TYPE

TIPO

V2403-M-T-3EB-MNT-1

REFENCE - NUMMER

NUMERO - NUMBER

RIFERIMENTO

270 884

pg.279

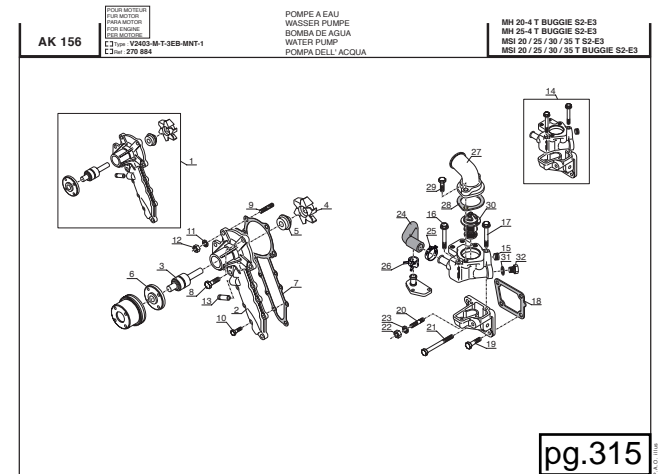
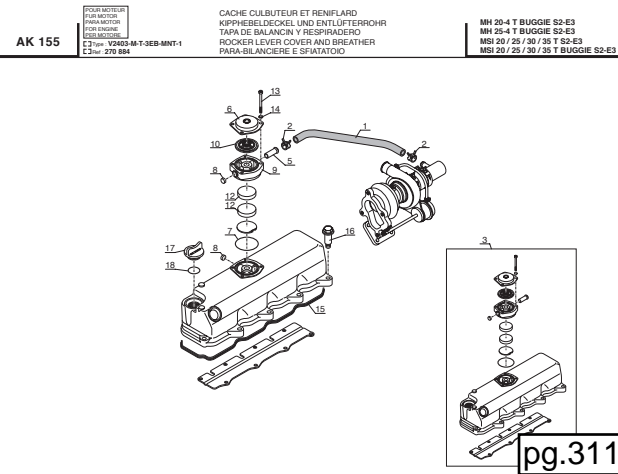
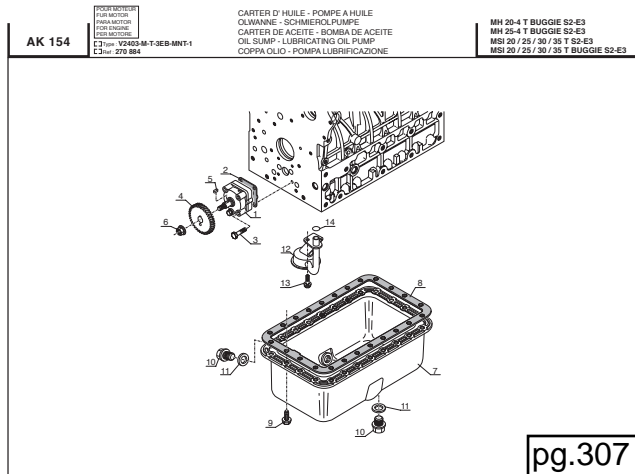
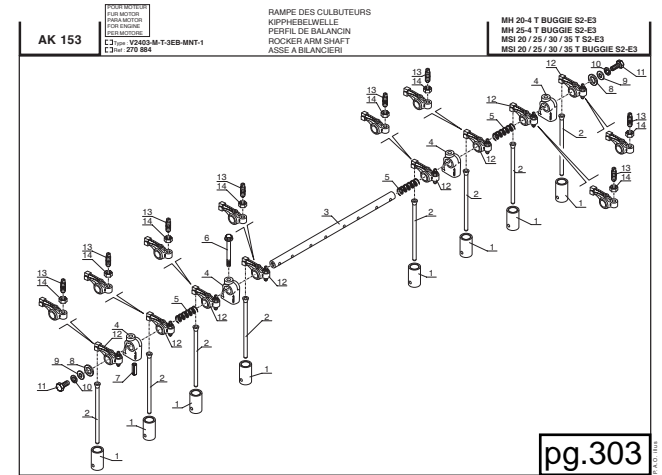
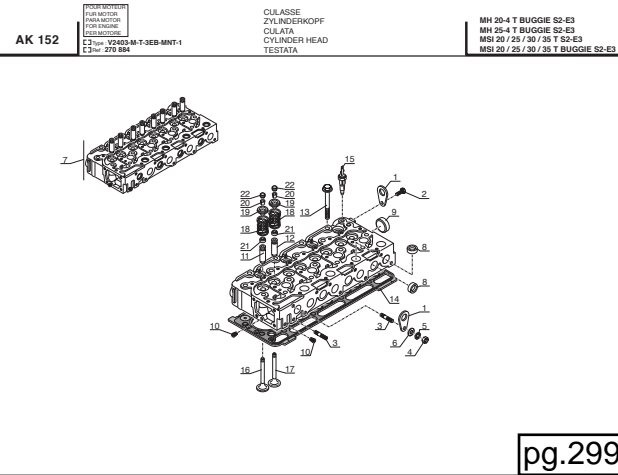
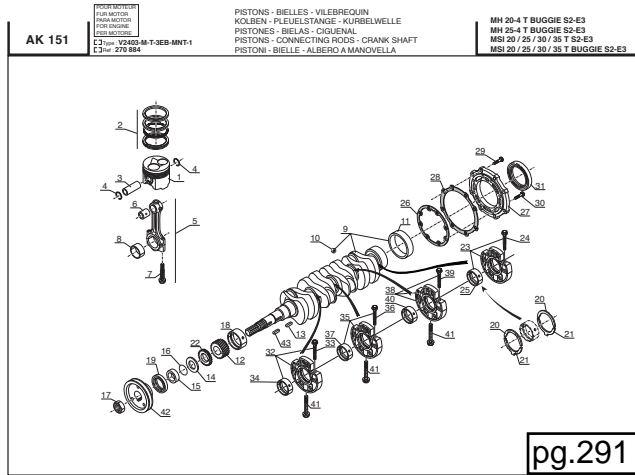
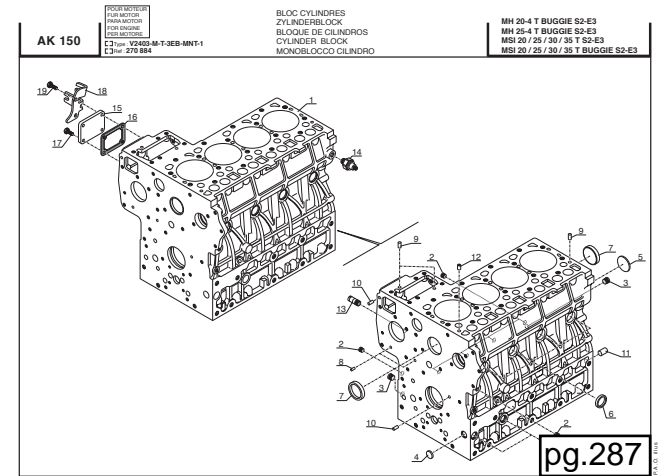
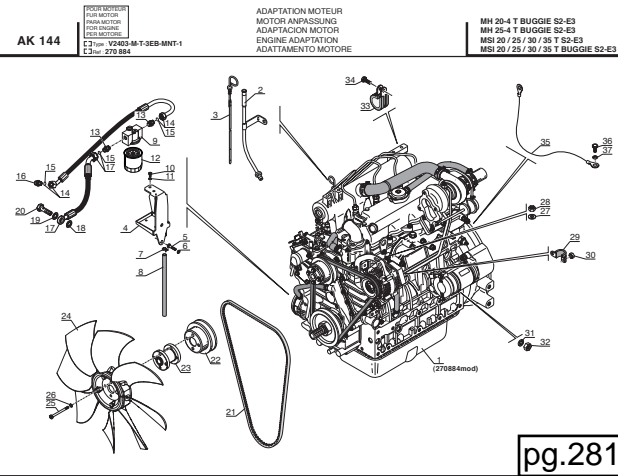

<b>AK 157</b>	FOR MOTOR FOR MOTOR FOR ENGINE FOR MOTOR	DISTRIBUTION ET ARBRE A CAMES STEUERGETRIEBE UND Nockenwelle DISTRIBUCION Y ARBOL DE LEVAS TIMING GEAR AND CAMSHAFT INGRANAGGI E ALBERO DELLA DISTRIBUZIONE	MH 20-4 T BUGGIE S2-E3 MH 25-4 T BUGGIE S2-E3 MSI 20 / 25 / 30 / 35 T S2-E3 MSI 20 / 25 / 30 / 35 T BUGGIE S2-E3
	<b>pg.319</b>		
	<small>04 / 04 / 03</small>		

<b>AK 158</b>	FOR MOTOR FOR MOTOR FOR ENGINE FOR MOTOR	REFROIDISSEUR D' HUILE ÖLKÜHLER ENFRÍADOR DE ACEITE OIL COOLER REFRIGERATORE INTEGRALE	MH 20-4 T BUGGIE S2-E3 MH 25-4 T BUGGIE S2-E3 MSI 20 / 25 / 30 / 35 T S2-E3 MSI 20 / 25 / 30 / 35 T BUGGIE S2-E3
	<b>pg.325</b>		
	<small>03 / 04 / 03</small>		

<b>AK 159</b>	FOR MOTOR FOR MOTOR FOR ENGINE FOR MOTOR	VOLANT-MOTEUR - DEMARREUR SCHWINGRAD - ANLASER VOLANTE-MOTOR - MOTOR DE ARANQUE FLYWHEEL - STARTER MOTOR VOLANO MOTORE - MOTORINO AVVIAMENTO	MH 20-4 T BUGGIE S2-E3 MH 25-4 T BUGGIE S2-E3 MSI 20 / 25 / 30 / 35 T S2-E3 MSI 20 / 25 / 30 / 35 T BUGGIE S2-E3
	<b>pg.329</b>		
	<small>03 / 04 / 03</small>		

<b>AK 160</b>	FOR MOTOR FOR MOTOR FOR ENGINE FOR MOTOR	ALTERNATEUR WECHSELSTROMGENERATOR ALTERNADOR ALTERNATOR ALTERNATORE	MH 20-4 T BUGGIE S2-E3 MH 25-4 T BUGGIE S2-E3 MSI 20 / 25 / 30 / 35 T S2-E3 MSI 20 / 25 / 30 / 35 T BUGGIE S2-E3
	<b>pg.333</b>		
	<small>03 / 04 / 03</small>		

<b>AK 161</b>	FOR MOTOR FOR MOTOR FOR ENGINE FOR MOTOR	ALTERNATEUR WECHSELSTROMGENERATOR ALTERNADOR ALTERNATOR ALTERNATORE	MH 20-4 T BUGGIE S2-E3 MH 25-4 T BUGGIE S2-E3 MSI 20 / 25 / 30 / 35 T S2-E3 MSI 20 / 25 / 30 / 35 T BUGGIE S2-E3
	<b>pg.337</b>		
	<small>03 / 04 / 03</small>		

<b>AK 162</b>	FOR MOTOR FOR MOTOR FOR ENGINE FOR MOTOR	COLLECTEUR D' ADMISION ANSAUGKÖRPER COLLECTOR DE ADMISION INTAKE MANIFOLD COLLETTORE ADMISSIONE	MH 20-4 T BUGGIE S2-E3 MH 25-4 T BUGGIE S2-E3 MSI 20 / 25 / 30 / 35 T S2-E3 MSI 20 / 25 / 30 / 35 T BUGGIE S2-E3
	<b>pg.339</b>		
	<small>03 / 04 / 03</small>		

<b>AK 163</b>	FOR MOTOR FOR MOTOR FOR ENGINE FOR MOTOR	COLLECTEUR D' ECHAPPEMENT AUSPUFFSAMMLER COLLECTOR DE ESCAPE EXHAUST MANIFOLD COLLETTORE DI SCARICO	MH 20-4 T BUGGIE S2-E3 MH 25-4 T BUGGIE S2-E3 MSI 20 / 25 / 30 / 35 T S2-E3 MSI 20 / 25 / 30 / 35 T BUGGIE S2-E3
	<b>pg.341</b>		
	<small>04 / 04 / 03</small>		

<b>AK 164</b>	FOR MOTOR FOR MOTOR FOR ENGINE FOR MOTOR	TURBO-COMPRESSEUR (Details) TURBOCOMPRESSOR (Einzeldetails) TURBOCOMPRESOR (Detalles) TURBOCHARGER (Details) TURBOCOMPRESSORE (Dettaglio)	MH 20-4 T BUGGIE S2-E3 MH 25-4 T BUGGIE S2-E3 MSI 20 / 25 / 30 / 35 T S2-E3 MSI 20 / 25 / 30 / 35 T BUGGIE S2-E3
	<b>pg.343</b>		
	<small>04 / 04 / 03</small>		

<b>AK 165</b>	FOR MOTOR FOR MOTOR FOR ENGINE FOR MOTOR	CIRCUIT COMBUSTIBLE BRENNSTOFFKREIS CIRCUITO COMBUSTIBILE FUEL CIRCUIT CIRCUITO COMBUSTIBILE	MH 20-4 T BUGGIE S2-E3 MH 25-4 T BUGGIE S2-E3 MSI 20 / 25 / 30 / 35 T S2-E3 MSI 20 / 25 / 30 / 35 T BUGGIE S2-E3
	<b>pg.347</b>		
	<small>04 / 04 / 03</small>		



AK 166

PROCEDEDI  
MANUTENZIONE  
E RIFORNIZIONE  
DEI COMPONENTI  
C37 per V2403-M-T-3EB-MNT-1  
C37 per 270 984

CIRCUIT COMBUSTIBLE  
BRENNSTOFFKREIS  
CIRCUITO COMBUSTIBILE  
FUEL CIRCUIT  
CIRCUITO COMBUSTIBILE

MH 20-4 T BUGGIE S2-E3  
MH 25-4 T BUGGIE S2-E3  
MSI 20 / 25 / 30 / 35 T S2-E3  
MSI 20 / 25 / 30 / 35 T BUGGIE S2-E3

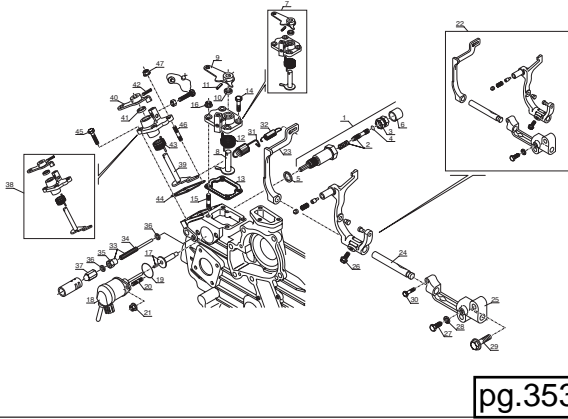

pg.353

01 04 110



**REDUCTEUR DE PRESSION  
DRUCKMINDERVENTIL  
REDUCTOR DE PRESION  
PRESSURE REDUCING VALVE  
REDUTTORE DI PRESSIONE**

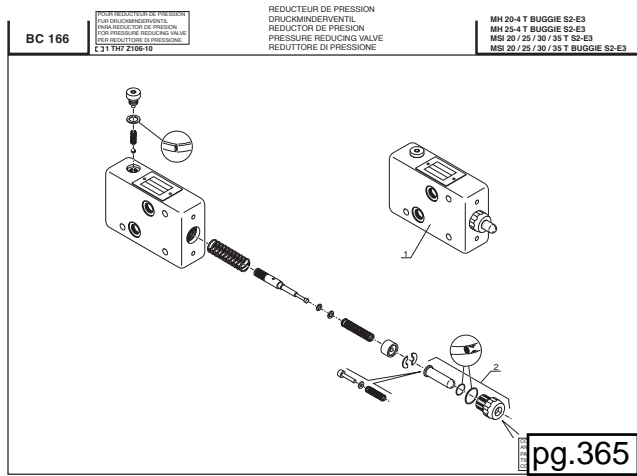
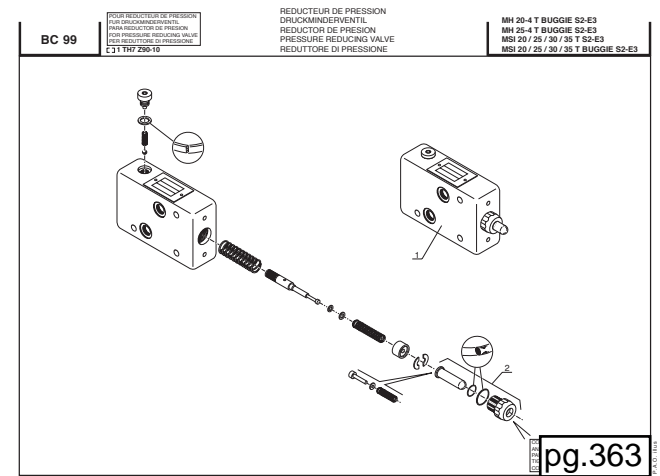
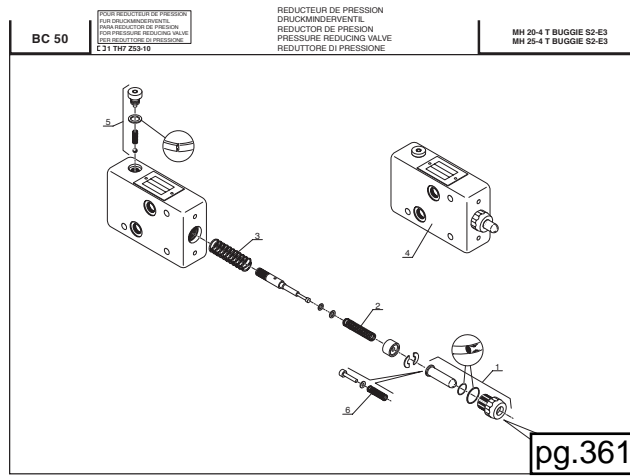

**POMPE A CYLINDREE VARIABLE  
VERSTELLPUMPE  
BOMBA DE CILINDRADA VARIABLE  
VARIABLE DISPLACEMENT PUMP  
POMPA CILINDRATA VARIABILE**

TYPE - TYPEN | A4VG71DA1 D7/32R  
TIPO - TYPE  
TIPO

REFERENCE - NUMBER |  
NUMERO - NUMBER | 270 375  
RIFERIMENTO

pg.367

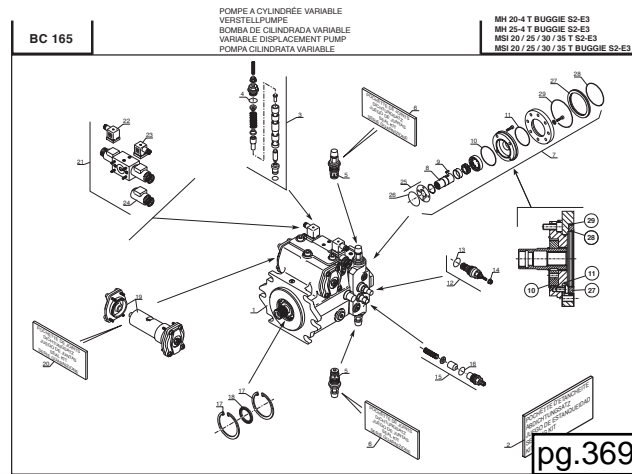

**MOTEUR A CYLINDREE FIXE  
MOTOR MIT FESTEM HUBRAUM  
MOTOR DE CILINDRADA FIJA  
MOTOR WITH FIXED CAPACITY  
MOTORE A CILINDRATA FISSA**

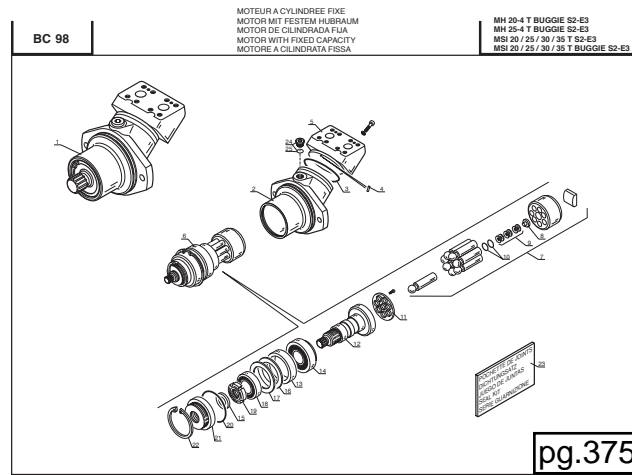

**MOTEUR DE ROUE  
RAD MOTOR  
MOTOR DE RUEDA  
WHEEL MOTOR  
MOTORINO DI RUOTE**

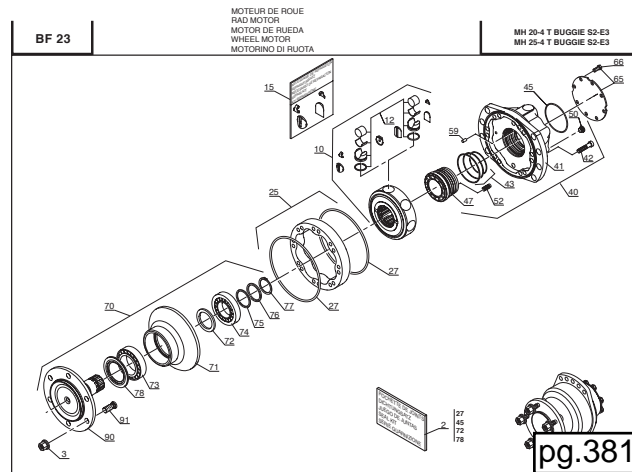



**REDUCTEUR DE ROUE**  
**RAD REDUKTION**  
**REDUCTOR DE RUEDA**  
**WHEEL REDUCING**  
**REDUTTORE DELLE RUOTE**

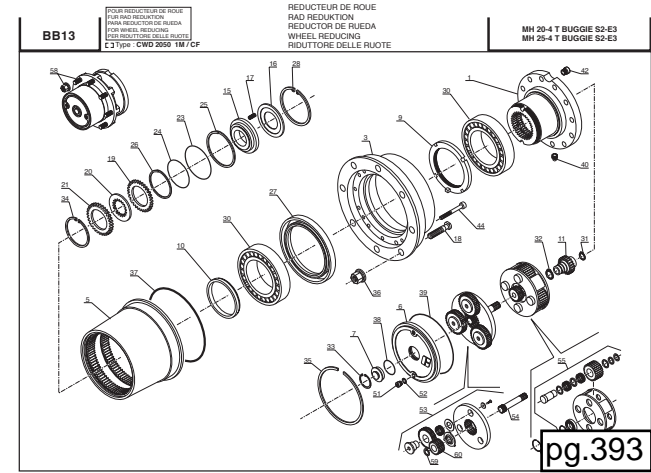
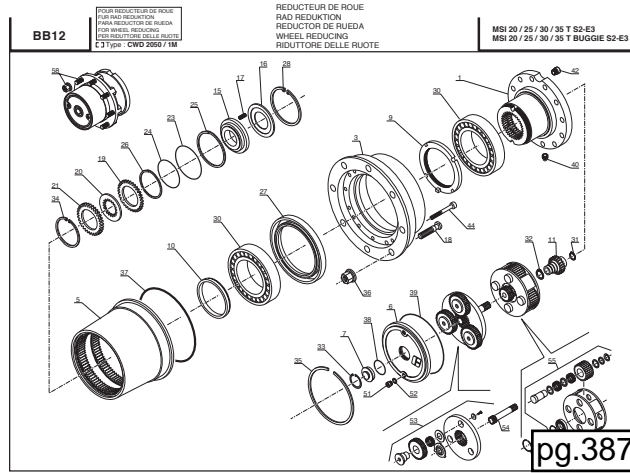

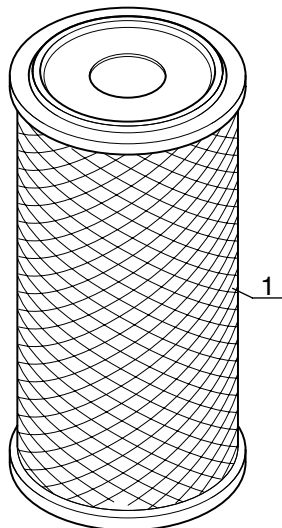

CARTOUCHE FILTRE A AIR  
 LUFTFILTEREINSATZ  
 CARTUCHO FILTRO DE AIRE  
 AIR FILTER CARTRIDGE  
 CARTUCCIA FILTRO ARIA

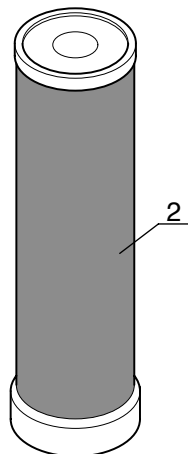

CARTOUCHE SECURITE FILTRE A AIR  
 SICHERHEIT LUFTFILTEREINSATZ  
 CARTUCHO SEGURIDAD FILTRO DE AIRE  
 SECURITY AIR FILTER CARTRIDGE  
 CARTUCCIA DI SICUREZZA FILTRO ARIA

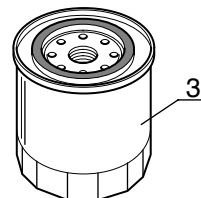

FILTRE A HUILE MOTEUR  
 OL FILTER MOTOR  
 FILTRO ACEITE MOTOR  
 OIL FILTER ENGINE  
 FILTRO OLIO MOTORE

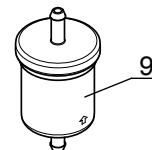

PREFILTRE A COMBUSTIBLE  
 BRENNSTOFVORFILTER  
 PREFILTRO A COMBUSTIBLE  
 FUEL PRE-FILTER  
 PREFILTRO COMBUSTIBILE

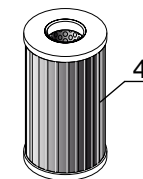

FILTRE A COMBUSTIBLE  
 BRENNSTOFFILTER  
 FILTRO A COMBUSTIBLE  
 FUEL FILTER  
 FILTRO COMBUSTIBILE

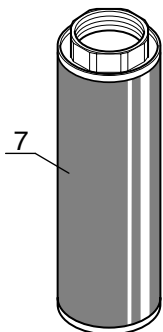

CREPINE DU CIRCUIT PRINCIPAL  
 SEIHER HAUPTKREIS  
 FILTRO DE PASO DE CIRCUITO PRINCIPAL  
 PRINCIPAL CIRCUIT STRAINER  
 PIGNA DE SERBATOIO OLIO

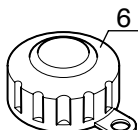

BOUCHON FILTRE DE REMPLISSAGE  
 EINFULLFILTERVERSCHLUSS  
 TAPON FILTRO DE LLENADO  
 FILLING PLUG FILTER  
 TAPPO FILTRO DI RIEMPIMENTO

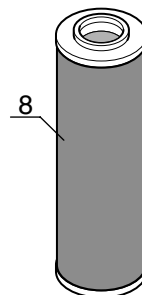

CARTOUCHE FILTRE A HUILE RETOUR HYDRAULIQUE  
 PATRONE HYDRAULIK RUCKGANG OLFILTER  
 CARTUCHO FILTRO ACEITE RETORNO HIDRAULICO  
 CARTRIDGE HYDRAULIC RETURN OIL FILTER  
 CARTUCCIA FILTRO OLIO RITORNO IDRAULICO

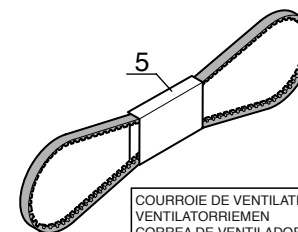

COURROIE DE VENTILATEUR  
 VENTILATORRIEMEN  
 CORREA DE VENTILADOR  
 FAN BELT  
 CINGHIA DI VENTILATORE

Catalogue : 647000

Qté-Menge-Cant-Qty-Q.ta

2 AA

188

M

1

FILTRES ET COURROIES  
 FILTERS UND KEILRIEMENS  
 FILTROS Y CORREAS  
 FILTERS AND BELTS  
 FILTRO E CINGHIA

1- MH20-4T BUG. S2-E3 11-  
 2- MH25-4T BUG. S2-E3 12-  
 3- MSI 20T S2-E3 13-  
 4- MSI 20T BUG. S2-E3 14-  
 5- MSI 25T S2-E3 15-  
 6- MSI 25T BUG. S2-E3 16-  
 7- MSI 30T S2-E3 17-  
 8- MSI 30T BUG. S2-E3 18-  
 9- MSI 35T S2-E3 19-  
 10- MSI 35T BUG. S2-E3 20-

Rep Hinw Fig Item Rif	Numéro Teil-Nr Numero Part-Nr Part-Nr	Désignation Bezeichnung Descripcion Description Descrizione	1	2	3	4	5	6	7	8	9	10	11	12	13	14	15	16	17	18	19	20
1	227959	Cartouche filtre à air - Luftfiltereinsatz Cartucho filtro de aire - Air filter cartridge Cartuccia filtro aria -	1	1	1	1	1	1	1	1	1	1										
2	227960	Cartouche sécurité filtre à air Sicherheit luftfiltereinsatz Cartucho seguridad filtro de aire Security air filter cartridge Cartuccia di sicurezza filtro aria	1	1	1	1	1	1	1	1	1	1										
3	272192	Filtre à huile moteur - Ol filter motor Filtro aceite motor - Oil filter engine Filtro olio motore -	1	1	1	1	1	1	1	1	1	1										
4	748087	Filtre à combustible - Brennstofffilter Filtro de combustible - Fuel filter Filtro gasolio -	1	1	1	1	1	1	1	1	1	1										
5	747994	Courroie - Riemen Correa - Belt Cinghia -	1	1	1	1	1	1	1	1	1	1										
6	62415	Bouchon filtre de remplissage - Einfullfilterverschluss Tapón filtro de llenado - Filling plug filter Tappo filtro di riempimento -	1	1	1	1	1	1	1	1	1	1										
7	77402	Crépine du circuit principal - Seiher hauptkreis Filtro de paso de circuito principal Principal circuit strainer Pigna circuito principale -	1	1	1	1	1	1	1	1	1	1										
8	602096	Cartouche filtre à huile retour hydraulique Patrone hydraulik ruckgang olfilter Cartucho filtro aceite retorno hidraulico Cartridge hydraulic return oil filter Cartuccia filtro olio ritorno idraulico	1	1	1	1	1	1	1	1	1	1										
9	272194	Préfiltre - Vorfilter Prefiltro - Pre-filter Prefiltro -	1	1	1	1	1	1	1	1	1	1										

3 AA 293

ROUES  
RAD  
RUEDAS  
WHEELS  
RUOTE

MSI 20 / 25 / 30 / 35 T S2-E3  
MSI 20 / 25 / 30 / 35 T BUGGIE S2-E3

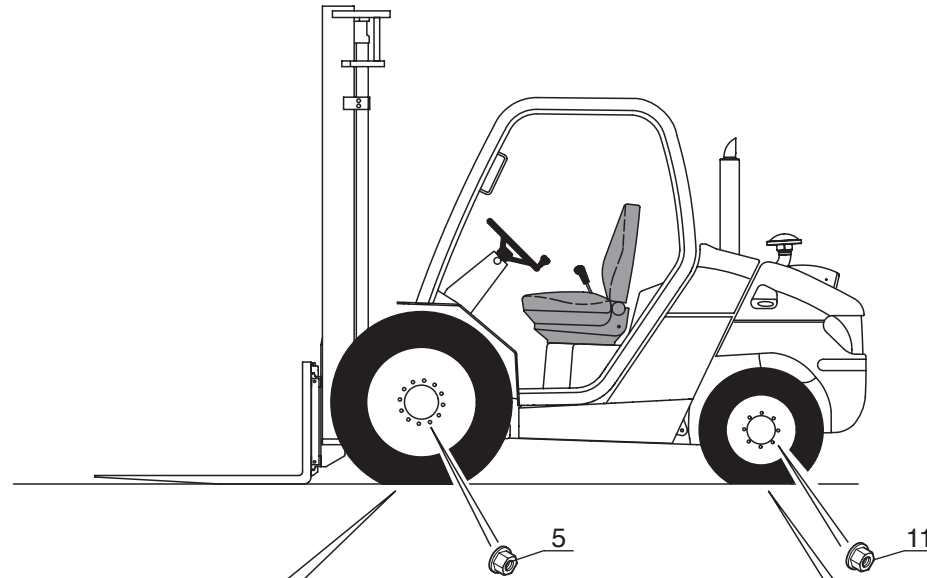

**GOOD YEAR**  
275/70 R22,5 RHS 148/145 M

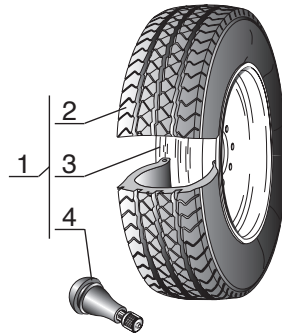

**CONTINENTAL**  
700x12 14PR IC40

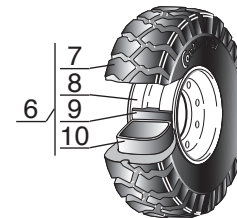

Catalogue : 647000

Qté-Menge-Cant-Qty-Q.ta

3 AA

294

M

1

ROUES  
RAD  
RUEDAS  
WHEELS  
RUOTA

1- MH20-4T BUG. S2-E3 11-  
2- MH25-4T BUG. S2-E3 12-  
3- MSI 20T S2-E3 13-  
4- MSI 20T BUG. S2-E3 14-  
5- MSI 25T S2-E3 15-  
6- MSI 25T BUG. S2-E3 16-  
7- MSI 30T S2-E3 17-  
8- MSI 30T BUG. S2-E3 18-  
9- MSI 35T S2-E3 19-  
10- MSI 35T BUG. S2-E3 20-

Rep Hinw Fig Item Rif	Numéro Teil-Nr Numero Part-Nr Part-Nr	Désignation Bezeichnung Descripcion Description Descrizione																				
			1	2	3	4	5	6	7	8	9	10	11	12	13	14	15	16	17	18	19	20
1	264861	Roue complète - Komplettrad Rueda completa - Complete wheel Ruota completo -	2	2																		
2	259992	Enveloppe 280/80R20 XMCL 133A8 MICHELIN Reifen Neumático - Tyre Pneumatico -	1	1																		
3	247437	Roue, nue 9 x20 8T N60 D23/275 Rad, allein Rueda, sola - Wheel, stripped Ruota, nudo -	1	1																		
4	60665	Valve - Ventil Válvula - Valve Valvola -	1	1																		
5	552751	Ecrou de roue - Radmutter Tuerca de rueda - Wheel nut Dado ruote -	16	16																		
6	247438	Roue complète - Komplettrad Rueda completa - Complete wheel Ruota completo -	2	2																		
7	194550	Enveloppe 27.10.12. 14PR IC 30 CONTINENTAL Reifen Neumático - Tyre Pneumatico -	1	1																		
8	247439	Roue, nue 8,00G12 5T P32 D15/140 Rad, allein Rueda, sola - Wheel, stripped Ruota, nudo -	1	1																		
9	185072	Flap - Klappe Protector - Flap Protezione -	1	1																		
10	194551	Chambre à air - Reifenschlauch Cámara de aire - Tube tyre Camera d'aria -	1	1																		

+

Catalogue : 647000

2

ROUES  
RAD  
RUEDAS  
WHEELS  
RUOTA

Qté-Menge-Cant-Qty-Q.ta

3 AA

294

M

1-	MH20-4T	BUG. S2-E3	11-
2-	MH25-4T	BUG. S2-E3	12-
3-	MSI 20T	S2-E3	13-
4-	MSI 20T	BUG. S2-E3	14-
5-	MSI 25T	S2-E3	15-
6-	MSI 25T	BUG. S2-E3	16-
7-	MSI 30T	S2-E3	17-
8-	MSI 30T	BUG. S2-E3	18-
9-	MSI 35T	S2-E3	19-
10-	MSI 35T	BUG. S2-E3	20-

Rep Hinw Fig Item Rif	Numéro Teil-Nr Numero Part-Nr Part-Nr	Désignation Bezeichnung Descripcion Description Descrizione
11	603708	Jeu d'écrou de roue - Rad mutter satz Juego de tuerca de rueda - Wheel nut kit Kit dado ruote -

1	2	3	4	5	6	7	8	9	10	11	12	13	14	15	16	17	18	19	20
2	2																		



3 AA 294

ROUES  
RAD  
RUEDAS  
WHEELS  
RUOTE

MH 20-4 T BUGGIE S2-E3  
MH 25-4 T BUGGIE S2-E3

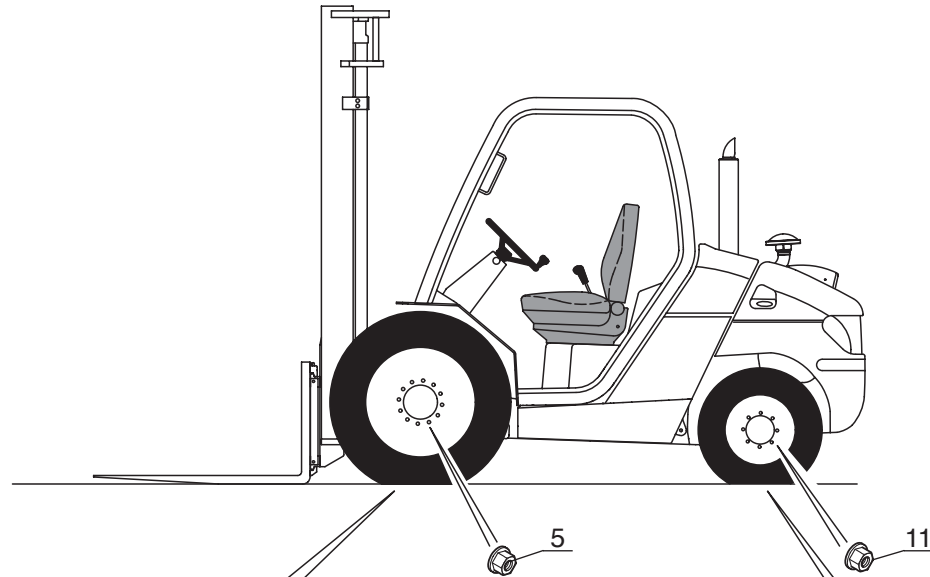

**MICHELIN**  
280/80 R20 XMCL 133A8

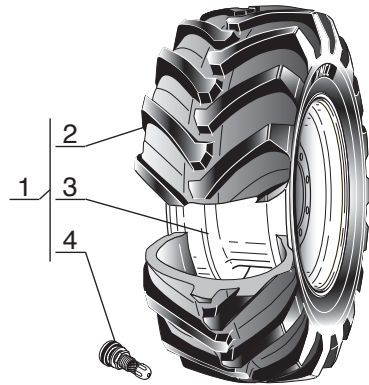

**CONTINENTAL**  
27.10.12 14PR IC30

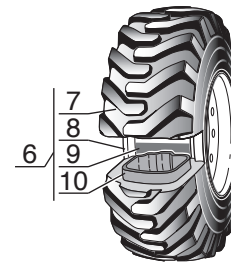



Catalogue : 647000

Qté-Menge-Cant-Qty-Q.ta

3 AA

294

M

1

ROUES  
RAD  
RUEDAS  
WHEELS  
RUOTA

1-	MH20-4T	BUG. S2-E3	11-
2-	MH25-4T	BUG. S2-E3	12-
3-	MSI 20T	S2-E3	13-
4-	MSI 20T	BUG. S2-E3	14-
5-	MSI 25T	S2-E3	15-
6-	MSI 25T	BUG. S2-E3	16-
7-	MSI 30T	S2-E3	17-
8-	MSI 30T	BUG. S2-E3	18-
9-	MSI 35T	S2-E3	19-
10-	MSI 35T	BUG. S2-E3	20-

Rep Hinw Fig Item Rif	Numéro Teil-Nr Numero Part-Nr Part-Nr	Désignation Bezeichnung Descripcion Description Descrizione	1	2	3	4	5	6	7	8	9	10	11	12	13	14	15	16	17	18	19	20
1	264861	Roue complète - Komplettrad Rueda completa - Complete wheel Ruota completo -	2	2																		
2	259992	Enveloppe 280/80R20 XMCL 133A8 MICHELIN Reifen Neumático - Tyre Pneumatico -	1	1																		
3	247437	Roue, nue 9 x20 8T N60 D23/275 Rad, allein Rueda, sola - Wheel, stripped Ruota, nudo -	1	1																		
4	60665	Valve - Ventil Válvula - Valve Valvola -	1	1																		
5	552751	Ecrou de roue - Radmutter Tuerca de rueda - Wheel nut Dado ruote -	16	16																		
6	247438	Roue complète - Komplettrad Rueda completa - Complete wheel Ruota completo -	2	2																		
7	194550	Enveloppe 27.10.12. 14PR IC 30 CONTINENTAL Reifen Neumático - Tyre Pneumatico -	1	1																		
8	247439	Roue, nue 8,00G12 5T P32 D15/140 Rad, allein Rueda, sola - Wheel, stripped Ruota, nudo -	1	1																		
9	185072	Flap - Klappe Protector - Flap Protezione -	1	1																		
10	194551	Chambre à air - Reifenschlauch Cámara de aire - Tube tyre Camera d'aria -	1	1																		

+

Catalogue : 647000

2

ROUES  
RAD  
RUEDAS  
WHEELS  
RUOTA

Qté-Menge-Cant-Qty-Q.ta

3 AA

294

M

1-	MH20-4T	BUG. S2-E3	11-
2-	MH25-4T	BUG. S2-E3	12-
3-	MSI 20T	S2-E3	13-
4-	MSI 20T	BUG. S2-E3	14-
5-	MSI 25T	S2-E3	15-
6-	MSI 25T	BUG. S2-E3	16-
7-	MSI 30T	S2-E3	17-
8-	MSI 30T	BUG. S2-E3	18-
9-	MSI 35T	S2-E3	19-
10-	MSI 35T	BUG. S2-E3	20-

Rep Hinw Fig Item Rif	Numéro Teil-Nr Numero Part-Nr Part-Nr	Désignation Bezeichnung Descripcion Description Descrizione
11	603708	Jeu d'écrou de roue - Rad mutter satz Juego de tuerca de rueda - Wheel nut kit Kit dado ruote -

1	2	3	4	5	6	7	8	9	10	11	12	13	14	15	16	17	18	19	20
2	2																		



4 AA 747

ADAPTATION MOTEUR-TRANSMISSION  
MOTOR-GETRIEBE ANPASSUNG  
ADAPTACION MOTOR-TRANSMISION  
ENGINE-TRANSMISSION ADAPTATION  
ADATTAMENTO MOTORE - TRASMISSIONE

MH 20-4 T BUGGIE S2-E3  
MH 25-4 T BUGGIE S2-E3  
MSI 20 / 25 / 30 / 35 T S2-E3  
MSI 20 / 25 / 30 / 35 T BUGGIE S2-E3

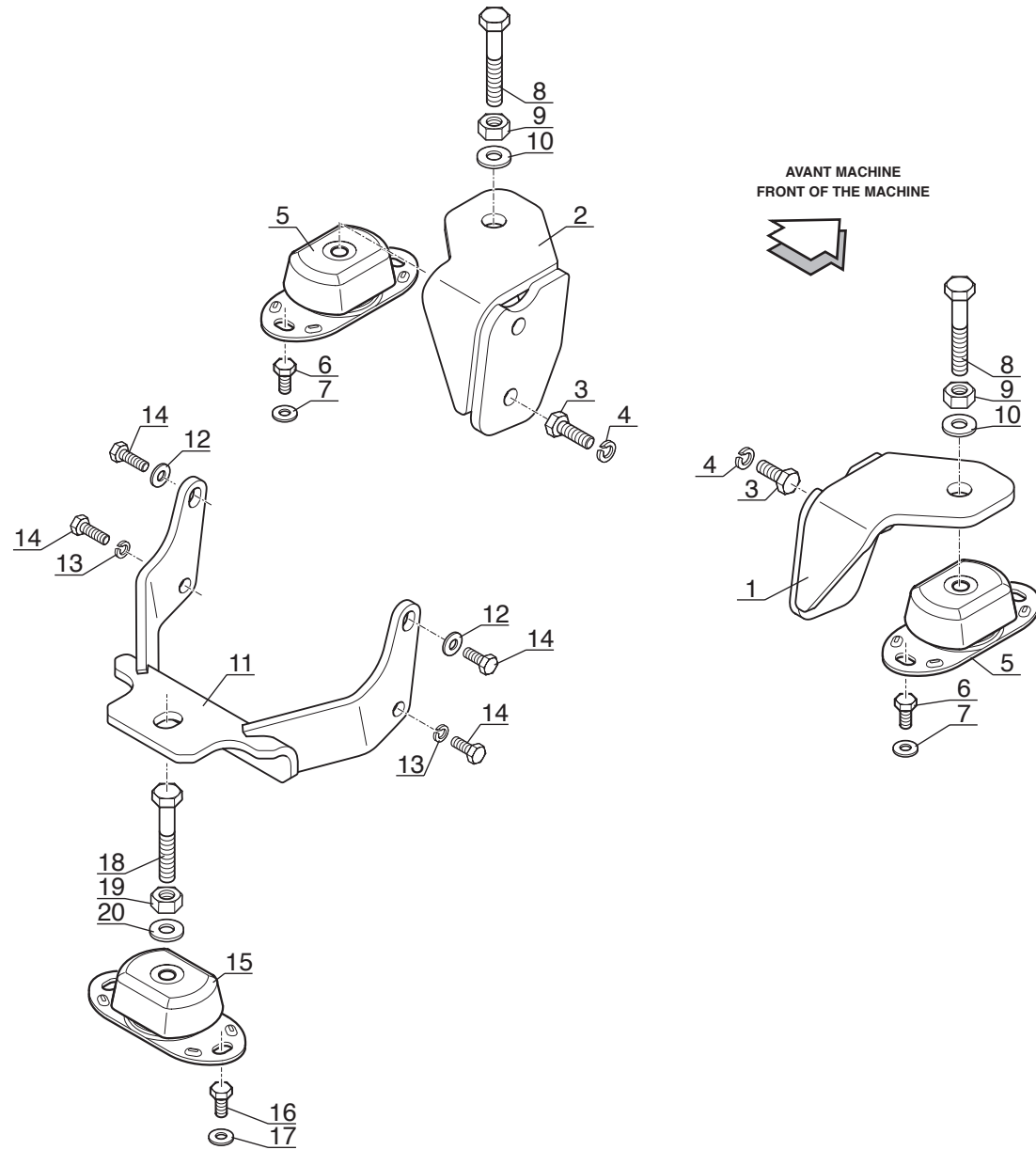

Catalogue : 647000

Qté-Menge-Cant-Qty-Q.ta

4 AA

747

M

1

ADAPTATION MOTEUR - TRANSMISSION  
 MOTOR - GETRIEBE ANPASSUNG  
 ADAPTACION MOTOR - TRANSMISION  
 ENGINE - TRANSMISSION ADAPTATION  
 ADATTAMENTO MOTORE - TRASMISSIONE

- 1- MH20-4T BUG. S2-E3 11-
- 2- MH25-4T BUG. S2-E3 12-
- 3- MSI 20T S2-E3 13-
- 4- MSI 20T BUG. S2-E3 14-
- 5- MSI 25T S2-E3 15-
- 6- MSI 25T BUG. S2-E3 16-
- 7- MSI 30T S2-E3 17-
- 8- MSI 30T BUG. S2-E3 18-
- 9- MSI 35T S2-E3 19-
- 10- MSI 35T BUG. S2-E3 20-

Rep Hinw Fig Item Rif	Numéro Teil-Nr Numero Part-Nr Part-Nr	Désignation Bezeichnung Descripcion Description Descrizione	Qté-Menge-Cant-Qty-Q.ta																			
			1	2	3	4	5	6	7	8	9	10	11	12	13	14	15	16	17	18	19	20
1	273452	Support moteur avant droit - Recht vorn motor träger Soporte motor delantero derecho R.H. front engine bracket Supporto motore anteriore destro	1	1	1	1	1	1	1	1	1	1										
2	273470	Support moteur avant gauche - Link vorn motor träger Soporte motor delantero izquierdo L.H. front engine bracket Supporto motore anteriore sinistro	1	1	1	1	1	1	1	1	1	1										
3	176716	Vis H,M14-150- 30-8.8-ZN8/C - Schraube Tornillo - Screw Vite -	4	4	4	4	4	4	4	4	4	4										
4	42256	Rondelle W14 ZN - Unterlegscheibe Arandela - Washer Rondella -	4	4	4	4	4	4	4	4	4	4										
5	247802	Silentbloc - Dampfer Amortiguador - Shock absorber Tasselo -	2	2	2	2	2	2	2	2	2	2										
6	44807	Vis H,M12- 25-8.8-ZN8/C - Schraube Tornillo - Screw Vite -	4	4	4	4	4	4	4	4	4	4										
7	77710	Rondelle HR12,5x 27x2,5ZN - Unterlegscheibe Arandela - Washer Rondella -	4	4	4	4	4	4	4	4	4	4										
8	58590	Vis H,M16- 60-8.8-ZN8/C - Schraube Tornillo - Screw Vite -	2	2	2	2	2	2	2	2	2	2										
9	42813	Ecrou H ,M16 zingué - Mutter Tuerca - Nut Dado -	2	2	2	2	2	2	2	2	2	2										
10	194287	Rondelle M 16 ZN 160HV - Unterlegscheibe Arandela - Washer Rondella -	2	2	2	2	2	2	2	2	2	2										
11	273479	Support moteur arrière - Hinter motor träger Soporte motor trasero - Rear engine bracket Supporto motore posteriore -	1	1	1	1	1	1	1	1	1	1										

+

Catalogue : 647000

2

ADAPTATION MOTEUR - TRANSMISSION  
 MOTOR - GETRIEBE ANPASSUNG  
 ADAPTACION MOTOR - TRANSMISION  
 ENGINE - TRANSMISSION ADAPTATION  
 ADATTAMENTO MOTORE - TRASMISSIONE

Qté-Menge-Cant-Qty-Q.ta

4 AA

747

M

1-	MH20-4T	BUG. S2-E3	11-
2-	MH25-4T	BUG. S2-E3	12-
3-	MSI 20T	S2-E3	13-
4-	MSI 20T	BUG. S2-E3	14-
5-	MSI 25T	S2-E3	15-
6-	MSI 25T	BUG. S2-E3	16-
7-	MSI 30T	S2-E3	17-
8-	MSI 30T	BUG. S2-E3	18-
9-	MSI 35T	S2-E3	19-
10-	MSI 35T	BUG. S2-E3	20-

Rep Hinw Fig Item Rif	Numéro Teil-Nr Numero Part-Nr Part-Nr	Désignation Bezeichnung Descripcion Description Descrizione																				
			1	2	3	4	5	6	7	8	9	10	11	12	13	14	15	16	17	18	19	20
12	77710	Rondelle HR12,5x 27x2,5ZN Arandela Rondella - Unterlegscheibe - Washer -	2	2	2	2	2	2	2	2	2	2										
13	42231	Rondelle W12 ZN Arandela Rondella - Unterlegscheibe - Washer -	2	2	2	2	2	2	2	2	2	2										
14	61958	Vis H,M12-125- 30-8.8-ZN8/C Tornillo Vite - Schraube - Screw -	4	4	4	4	4	4	4	4	4	4										
15	246414	Silentbloc Amortiguador Tasselo - Dampfer - Shock absorber -	1	1	1	1	1	1	1	1	1	1										
16	44807	Vis H,M12- 25-8.8-ZN8/C Tornillo Vite - Schraube - Screw -	2	2	2	2	2	2	2	2	2	2										
17	77710	Rondelle HR12,5x 27x2,5ZN Arandela Rondella - Unterlegscheibe - Washer -	2	2	2	2	2	2	2	2	2	2										
18	58590	Vis H,M16- 60-8.8-ZN8/C Tornillo Vite - Schraube - Screw -	1	1	1	1	1	1	1	1	1	1										
19	42813	Ecrou H ,M16 zingué Tuerca Dado - Mutter - Nut -	1	1	1	1	1	1	1	1	1	1										
20	194287	Rondelle M 16 ZN 160HV Arandela Rondella - Unterlegscheibe - Washer -	1	1	1	1	1	1	1	1	1	1										



4 AA 748

ADAPTATION MOTEUR-TRANSMISSION  
MOTOR-GETRIEBE ANPASSUNG  
ADAPTACION MOTOR-TRANSMISION  
ENGINE-TRANSMISSION ADAPTATION  
ADATTAMENTO MOTORE - TRASMISSIONE

MH 20-4 T BUGGIE S2-E3  
MH 25-4 T BUGGIE S2-E3  
MSI 20 / 25 / 30 / 35 T S2-E3  
MSI 20 / 25 / 30 / 35 T BUGGIE S2-E3

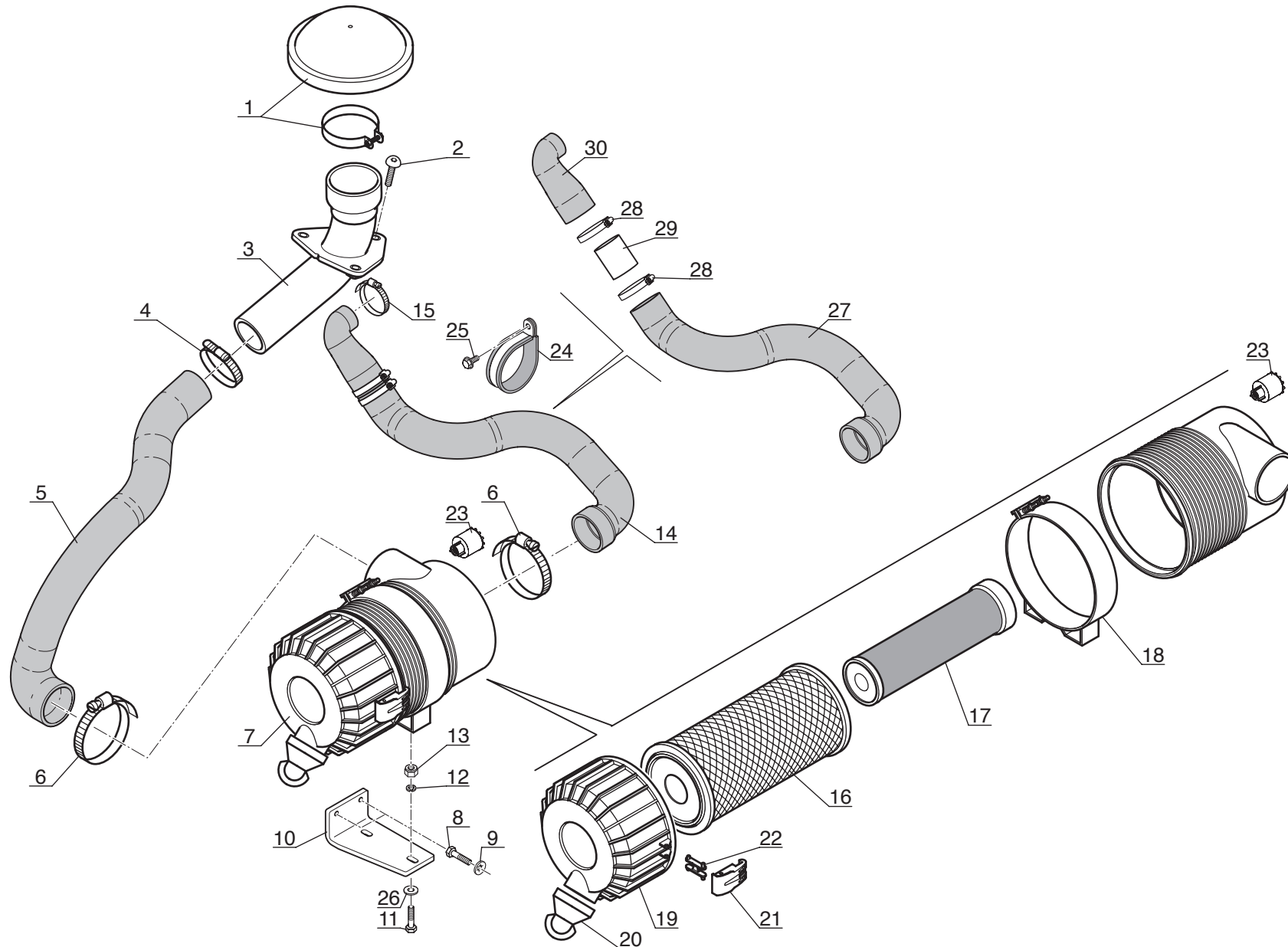



Catalogue : 647000

Qté-Menge-Cant-Qty-Q.ta

4 AA

748

M

1

ADAPTATION MOTEUR - TRANSMISSION  
 MOTOR - GETRIEBE ANPASSUNG  
 ADAPTACION MOTOR - TRANSMISION  
 ENGINE - TRANSMISSION ADAPTATION  
 ADATTAMENTO MOTORE - TRASMISSIONE

1-	MH20-4T	BUG. S2-E3	11-
2-	MH25-4T	BUG. S2-E3	12-
3-	MSI 20T	S2-E3	13-
4-	MSI 20T	BUG. S2-E3	14-
5-	MSI 25T	S2-E3	15-
6-	MSI 25T	BUG. S2-E3	16-
7-	MSI 30T	S2-E3	17-
8-	MSI 30T	BUG. S2-E3	18-
9-	MSI 35T	S2-E3	19-
10-	MSI 35T	BUG. S2-E3	20-

Rep Hinw Fig Item Rif	Numéro Teil-Nr Numero Part-Nr Part-Nr	Désignation Bezeichnung Descripcion Description Descrizione	Qté-Menge-Cant-Qty-Q.ta																			
			1	2	3	4	5	6	7	8	9	10	11	12	13	14	15	16	17	18	19	20
1	216484	Chapeau Tapadera Capello - Deckel - Cap -	1	1	1	1	1	1	1	1	1	1	1									
2	198433	Vis CBHc,M10- 20 zinguée Tornillo Vite - Schraube - Screw -	3	3	3	3	3	3	3	3	3	3										
3	247045	Tube Tubo Tubo - Rohr - Tube -	1	1	1	1	1	1	1	1	1	1										
4	195728	Collier Abrazadera Fascetta - Spannschelle - Clamp -	1	1	1	1	1	1	1	1	1	1										
5	247042	Durit Tubo flexible Manicotto - Schlauch - Hose -	1	1	1	1	1	1	1	1	1	1										
6	230501	Collier Abrazadera Fascetta - Spannschelle - Clamp -	2	2	2	2	2	2	2	2	2	2										
7	227958	Filtre à air complet Filtro de aire completo Filtro aria completo - Kompletter luftfilter - Complete air filter -	1	1	1	1	1	1	1	1	1	1										
8	42347	Vis H,M 8- 20-8.8-ZN8/C Tornillo Vite - Schraube - Screw -	2	2	2	2	2	2	2	2	2	2										
9	63351	Rondelle JZC 8 CAD.BICH Arandela Rondella - Unterlegscheibe - Washer -	2	2	2	2	2	2	2	2	2	2										
10	229646	Support Soporte Supporto - Träger - Bracket -	1	1	1	1	1	1	1	1	1	1										
11	57446	Vis H,M 8- 25-8.8-ZN8/C Tornillo Vite - Schraube - Screw -	2	2	2	2	2	2	2	2	2	2										

+

Catalogue : 647000

2

ADAPTATION MOTEUR - TRANSMISSION  
 MOTOR - GETRIEBE ANPASSUNG  
 ADAPTACION MOTOR - TRANSMISION  
 ENGINE - TRANSMISSION ADAPTATION  
 ADATTAMENTO MOTORE - TRASMISSIONE

Qté-Menge-Cant-Qty-Q.ta

4 AA

748

M

1-	MH20-4T	BUG. S2-E3	11-
2-	MH25-4T	BUG. S2-E3	12-
3-	MSI 20T	S2-E3	13-
4-	MSI 20T	BUG. S2-E3	14-
5-	MSI 25T	S2-E3	15-
6-	MSI 25T	BUG. S2-E3	16-
7-	MSI 30T	S2-E3	17-
8-	MSI 30T	BUG. S2-E3	18-
9-	MSI 35T	S2-E3	19-
10-	MSI 35T	BUG. S2-E3	20-

Rep Hinw Fig Item Rif	Numéro Teil-Nr Numero Part-Nr Part-Nr	Désignation Bezeichnung Descripcion Description Descrizione	1	2	3	4	5	6	7	8	9	10	11	12	13	14	15	16	17	18	19	20
12	42325	Rondelle W 8 ZN Arandela Rondella - Unterlegscheibe - Washer -	2	2	2	2	2	2	2	2	2	2	2									
13	54242	Ecrou H,FR M 8 C 8 ZN..C Tuerca Dado - Mutter - Nut -	2	2	2	2	2	2	2	2	2	2	2									
14	273990	Durit Tubo flexible Manicotto - Schlauch - Hose -	1	1	1	1	1	1	1	1	1	1	1									
15	204170	Collier Abrazadera Fascetta - Spannschelle - Clamp -	1	1	1	1	1	1	1	1	1	1	1									
16	227959	Cartouche filtre à air Cartucho filtro de aire Cartuccia filtro aria - Luftfiltereinsatz - Air filter cartridge -	1	1	1	1	1	1	1	1	1	1	1									
17	227960	Cartouche sécurité filtre à air Sicherheit luftfiltereinsatz Cartucho seguridad filtro de aire Security air filter cartridge Cartuccia di sicurezza filtro aria	1	1	1	1	1	1	1	1	1	1	1									
18	227961	Collier Abrazadera Fascetta - Spannschelle - Clamp -	1	1	1	1	1	1	1	1	1	1	1									
19	565521	Couvercle Tapadera Coperchio - Deckel - Cover -	1	1	1	1	1	1	1	1	1	1	1									
20	19187	Valve Válvula Valvola - Ventil - Valve -	1	1	1	1	1	1	1	1	1	1	1									
21	563488	Verrou Cerrojo Catenaccio - Riegel - Locker -	2	2	2	2	2	2	2	2	2	2	2									
22	563489	Biellette Biela Biella - Stange - Rod -	2	2	2	2	2	2	2	2	2	2	2									

+

Catalogue : 647000

3

ADAPTATION MOTEUR - TRANSMISSION  
 MOTOR - GETRIEBE ANPASSUNG  
 ADAPTACION MOTOR - TRANSMISION  
 ENGINE - TRANSMISSION ADAPTATION  
 ADATTAMENTO MOTORE - TRASMISSIONE

Qté-Menge-Cant-Qty-Q.ta

4 AA

748

M

1-	MH20-4T	BUG. S2-E3	11-
2-	MH25-4T	BUG. S2-E3	12-
3-	MSI 20T	S2-E3	13-
4-	MSI 20T	BUG. S2-E3	14-
5-	MSI 25T	S2-E3	15-
6-	MSI 25T	BUG. S2-E3	16-
7-	MSI 30T	S2-E3	17-
8-	MSI 30T	BUG. S2-E3	18-
9-	MSI 35T	S2-E3	19-
10-	MSI 35T	BUG. S2-E3	20-

Rep Hinw Fig Item Rif	Numéro Teil-Nr Numero Part-Nr Part-Nr	Désignation Bezeichnung Descripcion Description Descrizione	1	2	3	4	5	6	7	8	9	10	11	12	13	14	15	16	17	18	19	20
23	224776	Indicateur colmatage filtre à air Luftfilter ablagerung schalter Contactor colmatado filtro de aire Air filter clogging switch Indicatore filtro aria -	1	1	1	1	1	1	1	1	1	1										
24	406598	Collier - Spannschelle Abrazadera - Clamp Fascetta -	1	1	1	1	1	1	1	1	1	1										
25	259601	Vis H EMB M 8-20 8.8 DIN6921 - Schraube Tornillo - Screw Vite -	1	1	1	1	1	1	1	1	1	1										
26	61674	Rondelle M 8 ZN - Unterlegscheibe Arandela - Washer Rondella -	2	2	2	2	2	2	2	2	2	2										
27	273991	Durit - Schlauch Tubo flexible - Hose Manicotto -	1	1	1	1	1	1	1	1	1	1										
28	230816	Collier - Spannschelle Abrazadera - Clamp Fascetta -	2	2	2	2	2	2	2	2	2	2										
29	168409	Tube - Rohr Tubo - Tube Tubo -	1	1	1	1	1	1	1	1	1	1										
30	273992	Durit - Schlauch Tubo flexible - Hose Manicotto -	1	1	1	1	1	1	1	1	1	1										

4 AA 749

ADAPTATION MOTEUR-TRANSMISSION  
MOTOR-GETRIEBE ANPASSUNG  
ADAPTACION MOTOR-TRANSMISION  
ENGINE-TRANSMISSION ADAPTATION  
ADATTAMENTO MOTORE - TRASMISSIONE

MH 20-4 T BUGGIE S2-E3  
MH 25-4 T BUGGIE S2-E3  
MSI 20 / 25 / 30 / 35 T S2-E3  
MSI 20 / 25 / 30 / 35 T BUGGIE S2-E3

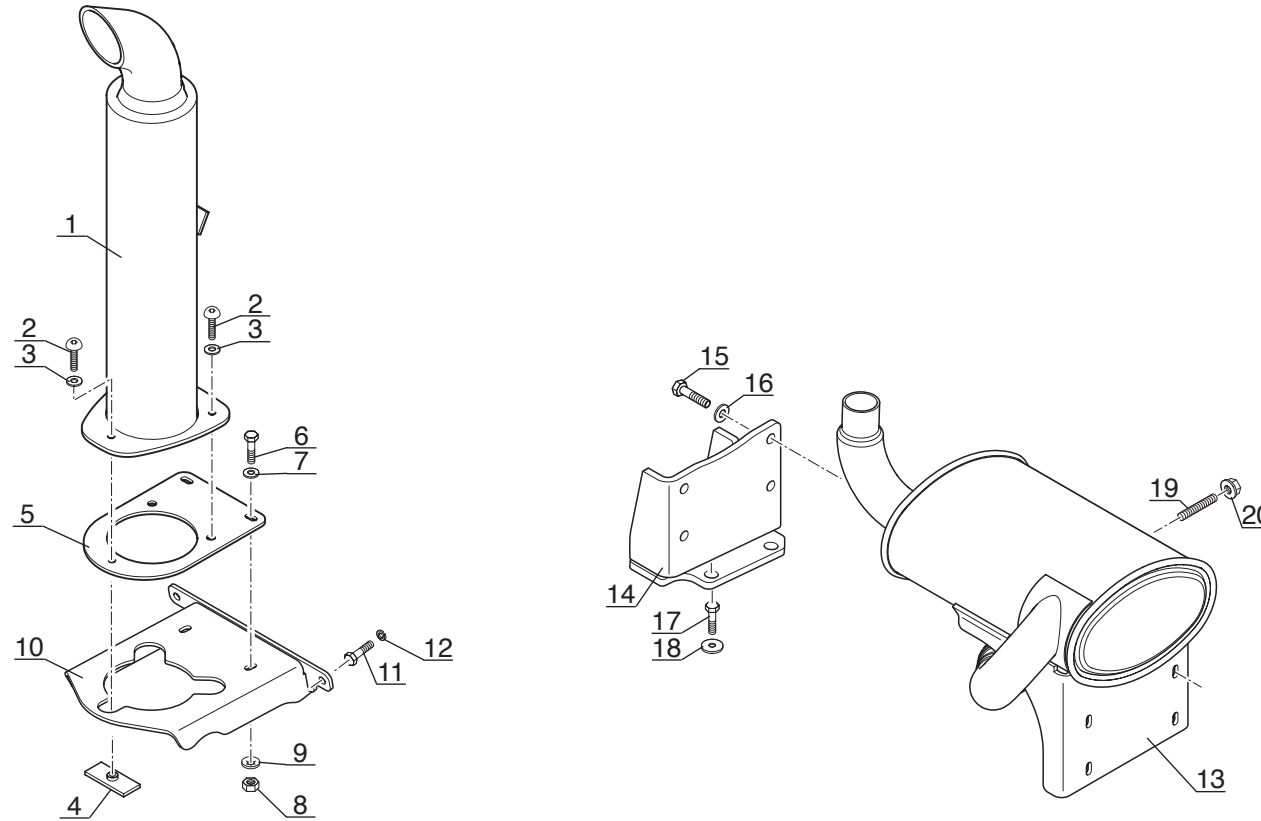

Catalogue : 647000

Qté-Menge-Cant-Qty-Q.ta

4 AA

749

M

1

ADAPTATION MOTEUR - TRANSMISSION  
 MOTOR - GETRIEBE ANPASSUNG  
 ADAPTACION MOTOR - TRANSMISION  
 ENGINE - TRANSMISSION ADAPTATION  
 ADATTAMENTO MOTORE - TRASMISSIONE

1-	MH20-4T	BUG. S2-E3	11-
2-	MH25-4T	BUG. S2-E3	12-
3-	MSI 20T	S2-E3	13-
4-	MSI 20T	BUG. S2-E3	14-
5-	MSI 25T	S2-E3	15-
6-	MSI 25T	BUG. S2-E3	16-
7-	MSI 30T	S2-E3	17-
8-	MSI 30T	BUG. S2-E3	18-
9-	MSI 35T	S2-E3	19-
10-	MSI 35T	BUG. S2-E3	20-

Rep Hinw Fig Item Rif	Numéro Teil-Nr Numero Part-Nr Part-Nr	Désignation Bezeichnung Descripcion Description Descrizione	Qté-Menge-Cant-Qty-Q.ta																			
			1	2	3	4	5	6	7	8	9	10	11	12	13	14	15	16	17	18	19	20
1	247808	Tuyau d'échappement Tubo de escape Tubo marmitta - Abgasrohr - Exhaust pipe -	1	1	1	1	1	1	1	1	1	1	1									
2	202418	Vis CBHc,M 8- 25-ZN NOIRE Tornillo Vite - Schraube - Screw -	3	3	3	3	3	3	3	3	3	3										
3	229564	Rondelle M 8 zinguée noire Arandela Rondella - Unterlagscheibe - Washer -	3	3	3	3	3	3	3	3	3											
4	230567	Plaque de protection Placa de protección Piastra di protezione - Schützplatte - Protection plate -	1	1	1	1	1	1	1	1	1	1										
5	248339	Plaque de fixation Placa de fijación Piastra di fissaggio - Befestigung Platte - Fastening plate -	1	1	1	1	1	1	1	1	1	1										
6	57446	Vis H,M 8- 25-8.8-ZN8/C Tornillo Vite - Schraube - Screw -	2	2	2	2	2	2	2	2	2	2										
7	229564	Rondelle M 8 zinguée noire Arandela Rondella - Unterlagscheibe - Washer -	2	2	2	2	2	2	2	2	2	2										
8	58528	Ecrou H ,M 8 ZN Tuerca Dado - Mutter - Nut -	2	2	2	2	2	2	2	2	2	2										
9	63351	Rondelle JZC 8 CAD.BICH Arandela Rondella - Unterlegscheibe - Washer -	2	2	2	2	2	2	2	2	2	2										
10	270908	Support Soporte Supporto - Halter - Bracket -	1	1	1	1	1	1	1	1	1	1										
11	63544	Vis H,M10- 30-8.8-ZN8/C Tornillo Vite - Schraube - Screw -	2	2	2	2	2	2	2	2	2	2										

+

Catalogue : 647000

2

ADAPTATION MOTEUR - TRANSMISSION  
 MOTOR - GETRIEBE ANPASSUNG  
 ADAPTACION MOTOR - TRANSMISION  
 ENGINE - TRANSMISSION ADAPTATION  
 ADATTAMENTO MOTORE - TRASMISSIONE

Qté-Menge-Cant-Qty-Q.ta

4 AA

749

M

1-	MH20-4T	BUG. S2-E3	11-
2-	MH25-4T	BUG. S2-E3	12-
3-	MSI 20T	S2-E3	13-
4-	MSI 20T	BUG. S2-E3	14-
5-	MSI 25T	S2-E3	15-
6-	MSI 25T	BUG. S2-E3	16-
7-	MSI 30T	S2-E3	17-
8-	MSI 30T	BUG. S2-E3	18-
9-	MSI 35T	S2-E3	19-
10-	MSI 35T	BUG. S2-E3	20-

Rep Hinw Fig Item Rif	Numéro Teil-Nr Numero Part-Nr Part-Nr	Désignation Bezeichnung Descripcion Description Descrizione	1	2	3	4	5	6	7	8	9	10	11	12	13	14	15	16	17	18	19	20	
12	42232	Rondelle W10 ZN Arandela Rondella - Unterlegscheibe - Washer -	2	2	2	2	2	2	2	2	2	2											
13	273684	Silencieux Silenciador Silenziator - Schalldämpfer - Muffler -	1	1	1	1	1	1	1	1	1	1											
14	277570	Support Soporte Supporto - Halter - Bracket -	1	1	1	1	1	1	1	1	1	1											
15	210001	Vis H,M10- 35-10.9-ZN8/C Tornillo Vite - Schraube - Screw -	4	4	4	4	4	4	4	4	4	4											
16	252205	Rondelle Arandela Rondella - Unterlegscheibe - Washer -	4	4	4	4	4	4	4	4	4	4											
17	210001	Vis H,M10- 35-10.9-ZN8/C Tornillo Vite - Schraube - Screw -	4	4	4	4	4	4	4	4	4	4											
18	252205	Rondelle Arandela Rondella - Unterlegscheibe - Washer -	4	4	4	4	4	4	4	4	4	4											
19	33617	Goujon Espárrago Prigioniero - Stiftschraube - Stud-bolt -	4	4	4	4	4	4	4	4	4	4											
20	254177	Ecrou H EMB M 8 C 8 ZN8/C Tuerca Dado - Mutter - Nut -	4	4	4	4	4	4	4	4	4	4											



4 AA 750

ADAPTATION MOTEUR-TRANSMISSION  
MOTOR-GETRIEBE ANPASSUNG  
ADAPTACION MOTOR-TRANSMISION  
ENGINE-TRANSMISSION ADAPTATION  
ADATTAMENTO MOTORE - TRASMISSIONE

MH 20-4 T BUGGIE S2-E3  
MH 25-4 T BUGGIE S2-E3  
MSI 20 / 25 / 30 / 35 T S2-E3  
MSI 20 / 25 / 30 / 35 T BUGGIE S2-E3

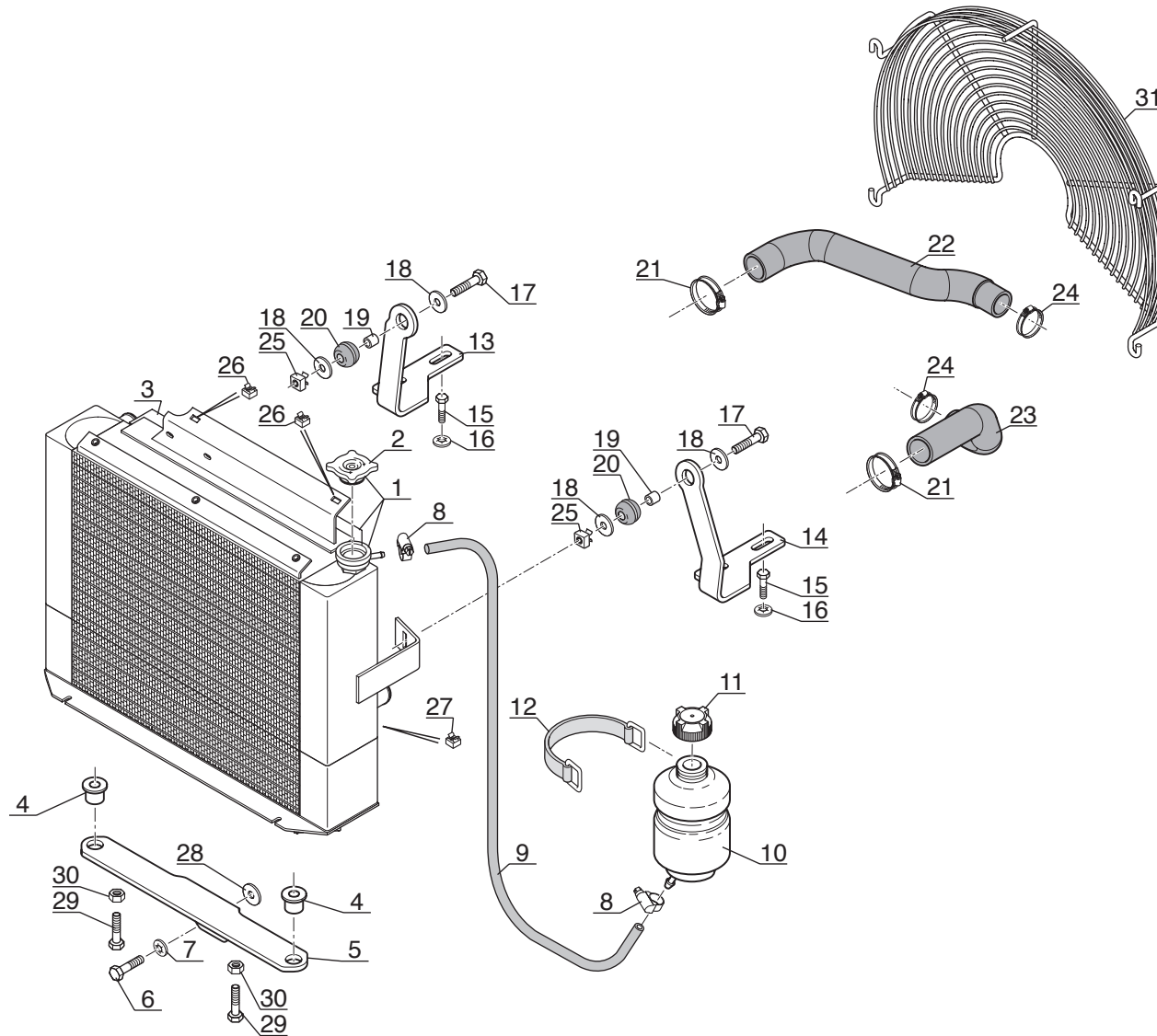



Catalogue : 647000

1	ADAPTATION MOTEUR - TRANSMISSION MOTOR - GETRIEBE ANPASSUNG ADAPTACION MOTOR - TRANSMISION ENGINE - TRANSMISSION ADAPTATION ADATTAMENTO MOTORE - TRASMISSIONE			Qté-Menge-Cant-Qty-Q.ta							4 AA		750		M								
	Rep Hinw Fig Item Rif	Numéro Teil-Nr Numero Part-Nr Part-Nr	Désignation Bezeichnung Descripcion Description Descrizione	1	2	3	4	5	6	7	8	9	10	11	12	13	14	15	16	17	18	19	20
1	274197	Radiateur Radiador Radiatore	- Kühler - Radiator -	1	1	1	1	1	1	1	1	1	1										
2	703009	Bouchon de remplissage Tapón de llenado Tappo di riempimento	- Einfüllverschluss - Filling plug -	1	1	1	1	1	1	1	1	1	1										
3	748146	Buse de radiateur Conducto de radiador Ugello radiatore	- Luftleitblech - Radiator nozzle -	1	1	1	1	1	1	1	1	1	1										
4	167187	Bague Anillo Anello	- Büchse - Bushing -	2	2	2	2	2	2	2	2	2	2										
5	247138	Support radiateur Soporte radiador Supporto radiatore	- Kühler träger - Radiator bracket -	1	1	1	1	1	1	1	1	1	1										
6	63544	Vis H,M10- 30-8.8-ZN8/C Tornillo Vite	- Schraube - Screw -	1	1	1	1	1	1	1	1	1	1										
7	183026	Rondelle JZC10 10,2x26 x1,4CAD.BICH Unterlegscheibe Arandela Rondella	- Washer -	1	1	1	1	1	1	1	1	1	1										
8	479218	Collier Abrazadera Fascetta	- Spannschelle - Clamp -	2	2	2	2	2	2	2	2	2	2										
9	194344	Durit Tubo flexible Manicotto	- Schlauch - Hose -	1	1	1	1	1	1	1	1	1	1										
10	182415	Vase d'expansion Vaso de expansion Vaso dall'espansione	- Ausdehnung vase - Expansion chamber -	1	1	1	1	1	1	1	1	1	1										
11	228805	Bouchon Tapón Tappo	- Stopfen - Plug -	1	1	1	1	1	1	1	1	1	1										

2

## Catalogue : 647000

ADAPTATION MOTEUR - TRANSMISSION  
 MOTOR - GETRIEBE ANPASSUNG  
 ADAPTACION MOTOR - TRANSMISION  
 ENGINE - TRANSMISSION ADAPTATION  
 ADATTAMENTO MOTORE - TRASMISSIONE

Qté-Menge-Cant-Qty-Q.ta

4 AA

750

M

Rep Hinw Fig Item Rif	Numéro Teil-Nr Numero Part-Nr Part-Nr	Désignation Bezeichnung Descripcion Description Descrizione																				
			1	2	3	4	5	6	7	8	9	10	11	12	13	14	15	16	17	18	19	20
			1- MH20-4T BUG. S2-E3	11-																		
			2- MH25-4T BUG. S2-E3	12-																		
			3- MSI 20T S2-E3	13-																		
			4- MSI 20T BUG. S2-E3	14-																		
			5- MSI 25T S2-E3	15-																		
			6- MSI 25T BUG. S2-E3	16-																		
			7- MSI 30T S2-E3	17-																		
			8- MSI 30T BUG. S2-E3	18-																		
			9- MSI 35T S2-E3	19-																		
			10- MSI 35T BUG. S2-E3	20-																		
12	198167	Sangle Cincha Cinghia	- Tragband - Webbing -		1	1	1	1	1	1	1	1	1									
13	274147	Support radiateur gauche Soporte radiador izquierdo Supporto radiatore sinistro	- Link kühler träger - L.H. radiator bracket -		1	1	1	1	1	1	1	1	1									
14	274149	Support radiateur droit Soporte radiador derecho Supporto radiatore destro	- Recht kühler träger - R.H. radiator bracket -		1	1	1	1	1	1	1	1	1									
15	42347	Vis H,M 8- 20-8.8-ZN8/C Tornillo Vite	- Schraube - Screw -		4	4	4	4	4	4	4	4	4									
16	63351	Rondelle JZC 8 CAD.BICH Arandela Rondella	- Unterlegscheibe - Washer -		4	4	4	4	4	4	4	4	4									
17	61323	Vis H,M 8- 35-8.8-ZN8/C Tornillo Vite	- Schraube - Screw -		2	2	2	2	2	2	2	2	2									
18	44025	Rondelle SP 8,5x 30 x 3 ZN Arandela Rondella	- Unterlegscheibe - Washer -		4	4	4	4	4	4	4	4	4									
19	479809	Tube Tubo Tubo	- Rohr - Tube -		2	2	2	2	2	2	2	2	2									
20	202118	Passe-fil Arandela de gaucho Passo-filo	- Gummischeibe - Cable grommet -		2	2	2	2	2	2	2	2	2									
21	232025	Collier Abrazadera Fascetta	- Spannschelle - Clamp -		2	2	2	2	2	2	2	2	2									
22	274150	Durit supérieure Tubo flexible superior Manicotto superiore	- Ober Schlauch - Upper hose -		1	1	1	1	1	1	1	1	1									

+

Catalogue : 647000

3

ADAPTATION MOTEUR - TRANSMISSION  
 MOTOR - GETRIEBE ANPASSUNG  
 ADAPTACION MOTOR - TRANSMISION  
 ENGINE - TRANSMISSION ADAPTATION  
 ADATTAMENTO MOTORE - TRASMISSIONE

Qté-Menge-Cant-Qty-Q.ta

4 AA

750

M

1-	MH20-4T	BUG. S2-E3	11-
2-	MH25-4T	BUG. S2-E3	12-
3-	MSI 20T	S2-E3	13-
4-	MSI 20T	BUG. S2-E3	14-
5-	MSI 25T	S2-E3	15-
6-	MSI 25T	BUG. S2-E3	16-
7-	MSI 30T	S2-E3	17-
8-	MSI 30T	BUG. S2-E3	18-
9-	MSI 35T	S2-E3	19-
10-	MSI 35T	BUG. S2-E3	20-

Rep Hinw Fig Item Rif	Numéro Teil-Nr Numero Part-Nr Part-Nr	Désignation Bezeichnung Descripcion Description Descrizione	1	2	3	4	5	6	7	8	9	10	11	12	13	14	15	16	17	18	19	20
23	274986	Durit inférieure Tubo flexible inferior Manicotto inferiore - Unter Schlauch - Lower hose -	1	1	1	1	1	1	1	1	1	1										
24	218468	Collier Abrazadera Fascetta - Spannschelle - Clamp -	2	2	2	2	2	2	2	2	2	2										
25	87535	Ecrou EQC M 8 Tuerca Dado - Mutter - Nut -	2	2	2	2	2	2	2	2	2	2										
26	202559	Ecrou EQC M 6 E zingué Tuerca Dado - Mutter - Nut -	2	2	2	2	2	2	2	2	2	2										
27	178125	Ecrou EQC M 6 C Tuerca Dado - Mutter - Nut -	4	4	4	4	4	4	4	4	4	4										
28	61675	Rondelle L 10 ZN Arandela Rondella - Unterlegscheibe - Washer -	X	X	X	X	X	X	X	X	X	X										
29	63544	Vis H,M10- 30-8.8-ZN8/C Tornillo Vite - Schraube - Screw -	2	2	2	2	2	2	2	2	2	2										
30	56354	Ecrou H ,M10 zingué Tuerca Dado - Mutter - Nut -	2	2	2	2	2	2	2	2	2	2										
31	274304	Grille Rejilla Griglia - Gitter - Grid -	1	1	1	1	1	1	1	1	1	1										

# 4 AB 182

## CIRCUIT TRANSMISSION HYDROSTATIQUE HYDROSTATIK GETRIEBKREIS CIRCUITO TRANSMISION HIDROSTATICO HYDROSTATIC TRANSMISSION CIRCUIT CIRCUITO TRASMISONE IDROSTATICO

MSI 20 / 25 / 30 / 35 T S2-E3  
MSI 20 / 25 / 30 / 35 T BUGGIE S2-E3

POUR FLEXIBLE ET RACCORD  
FÜR SCHLAUCH UND VERSCHRAUBUNG  
PARA FLEXIBLE Y RACOR  
FOR HOSE AND CONNECTION  
PER FLESSIBILE E RACCORDO

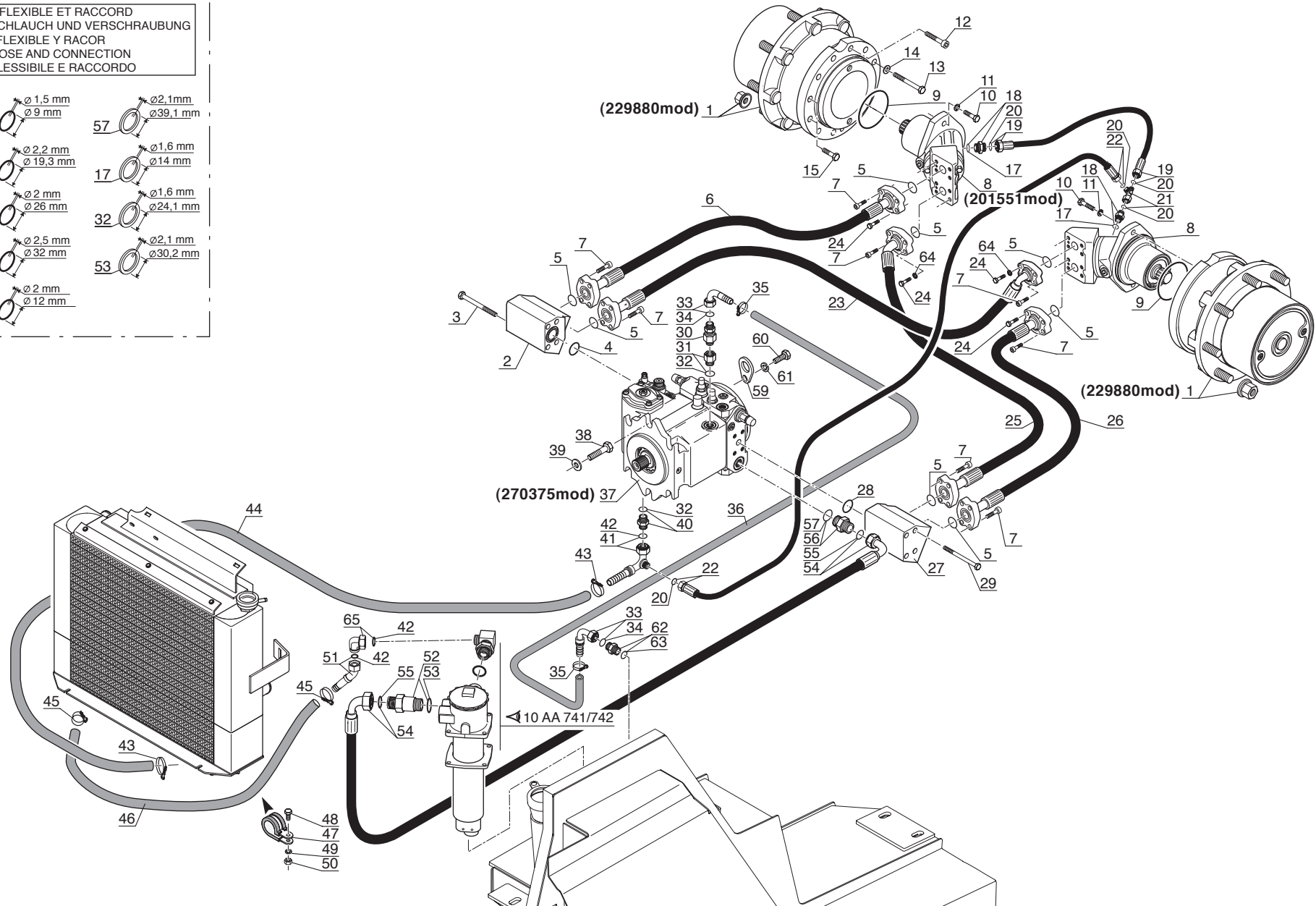
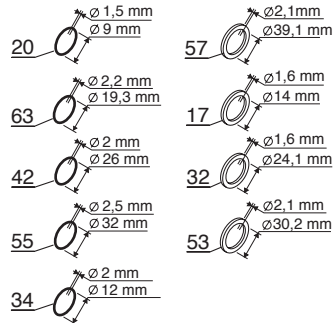

Catalogue : 647000

Qté-Menge-Cant-Qty-Q.ta

4 AB

182

M

1

CIRCUIT TRANSMISSION HYDROSTATIQUE  
 HYDROSTATIK GETRIEBKREIS  
 CIRCUITO TRANSMISION HIDROSTATICO  
 HYDROSTATIC TRANSMISSION CIRCUIT  
 CIRCUITO TRASMISSIONE IDROSTATICA

1- MH20-4T BUG. S2-E3 11-  
 2- MH25-4T BUG. S2-E3 12-  
 3- MSI 20T S2-E3 13-  
 4- MSI 20T BUG. S2-E3 14-  
 5- MSI 25T S2-E3 15-  
 6- MSI 25T BUG. S2-E3 16-  
 7- MSI 30T S2-E3 17-  
 8- MSI 30T BUG. S2-E3 18-  
 9- MSI 35T S2-E3 19-  
 10- MSI 35T BUG. S2-E3 20-

Rep Hinw Fig Item Rif	Numéro Teil-Nr Numero Part-Nr Part-Nr	Désignation Bezeichnung Descripcion Description Descrizione	1	2	3	4	5	6	7	8	9	10	11	12	13	14	15	16	17	18	19	20
1	229880	Réducteur de roue - Rad reduktion Reductor de rueda - Wheel reducing Riduttore di ruota -			2	2	2	2	2	2	2	2										
2	247805	Bloc d'alimentation gauche - Link Zuschiebungblock Bloque de alimentación izquierdo L.H. feed block Blocco alimentazione sinistro -			1	1	1	1	1	1	1	1										
3	247710	Vis H,M12-140-10.9-ZN8/C - Schraube Tornillo - Screw Vite -			4	4	4	4	4	4	4	4										
4	27188	Joint torique - "0" ring Junta tórica - "0" ring Anello OR -			1	1	1	1	1	1	1	1										
5	85822	Joint torique - "0" ring Junta tórica - "0" ring Anello OR -			8	8	8	8	8	8	8	8										
6	248190	Flexible (Lg 810) - Schlauch Flexible - Hose Flessibile -			1	1	1	1	1	1	1	1										
7	202250	Vis CHc,M10- 35 zinguée - Schraube Tornillo - Screw Vite -			24	24	24	24	24	24	24	24										
8	201551	Moteur hydrostatique complet - Kompletter hydrostatik motor Motor hidrostático completo - Complete hydrostatic motor Motore idrostatico completo -			2	2	2	2	2	2	2	2										
9	203510	Joint torique - "0" ring Junta tórica - "0" ring Anello OR -			2	2	2	2	2	2	2	2										
10	29475	Vis H,M12- 45-8.8-ZN8/C - Schraube Tornillo - Screw Vite -			4	4	4	4	4	4	4	4										
11	42231	Rondelle W12 ZN - Unterlegscheibe Arandela - Washer Rondella -			4	4	4	4	4	4	4	4										

+

Catalogue : 647000

2

CIRCUIT TRANSMISSION HYDROSTATIQUE  
 HYDROSTATIK GETRIEBKREIS  
 CIRCUITO TRANSMISION HIDROSTATICO  
 HYDROSTATIC TRANSMISSION CIRCUIT  
 CIRCUITO TRASMISSIONE IDROSTATICA

Qté-Menge-Cant-Qty-Q.ta

4 AB

182

M

1-	MH20-4T	BUG. S2-E3	11-
2-	MH25-4T	BUG. S2-E3	12-
3-	MSI 20T	S2-E3	13-
4-	MSI 20T	BUG. S2-E3	14-
5-	MSI 25T	S2-E3	15-
6-	MSI 25T	BUG. S2-E3	16-
7-	MSI 30T	S2-E3	17-
8-	MSI 30T	BUG. S2-E3	18-
9-	MSI 35T	S2-E3	19-
10-	MSI 35T	BUG. S2-E3	20-

Rep Hinw Fig Item Rif	Numéro Teil-Nr Numero Part-Nr Part-Nr	Désignation Bezeichnung Description Descrizione	Qté-Menge-Cant-Qty-Q.ta																			
			1	2	3	4	5	6	7	8	9	10	11	12	13	14	15	16	17	18	19	20
12	210002	Vis CHc,M16- 90 zinguée Tornillo Vis - Schraube - Screw -			2	2	2	2	2	2	2	2										
13	167409	Vis H,M16-110-10.9-ZN8/C Tornillo Vite - Schraube - Screw -			18	18	18	18	18	18	18	18										
14	77711	Rondelle HR17 x 30x3 ZN Arandela Rondella - Unterlegscheibe - Washer -			18	18	18	18	18	18	18	18										
15	217186	Vis H,M16- 35-10.9-ZN8/C Tornillo Vite - Schraube - Screw -			4	4	4	4	4	4	4	4										
17	190016	Joint d'étanchéité Junta de estanqueidad Guarnizióne - Dichtungsring - Seal -			X	X	X	X	X	X	X	X										
18	248395	Raccord Union Racor Raccordo - Verschraubung - Connection -			2	2	2	2	2	2	2	2										
19	248397	Flexible (Lg 650) Flexible Flessibile - Schlauch - Hose -			1	1	1	1	1	1	1	1										
20	190874	Joint torique Junta tórica Anello OR - "O" ring - "O" ring -			X	X	X	X	X	X	X	X										
21	204343	Raccord Té Adapteur Racor Raccordo - Verschraubung - Connection -			1	1	1	1	1	1	1	1										
22	169037	Flexible (Lg 1350) Flexible Flessibile - Schlauch - Hose -			1	1	1	1	1	1	1	1										
23	247716	Flexible (Lg 940) Flexible Flessibile - Schlauch - Hose -			1	1	1	1	1	1	1	1										

+

Catalogue : 647000

3

CIRCUIT TRANSMISSION HYDROSTATIQUE  
 HYDROSTATIK GETRIEBKREIS  
 CIRCUITO TRANSMISION HIDROSTATICO  
 HYDROSTATIC TRANSMISSION CIRCUIT  
 CIRCUITO TRASMISSIONE IDROSTATICA

Qté-Menge-Cant-Qty-Q.ta

4 AB

182

M

1-	MH20-4T	BUG. S2-E3	11-
2-	MH25-4T	BUG. S2-E3	12-
3-	MSI 20T	S2-E3	13-
4-	MSI 20T	BUG. S2-E3	14-
5-	MSI 25T	S2-E3	15-
6-	MSI 25T	BUG. S2-E3	16-
7-	MSI 30T	S2-E3	17-
8-	MSI 30T	BUG. S2-E3	18-
9-	MSI 35T	S2-E3	19-
10-	MSI 35T	BUG. S2-E3	20-

Rep Hinw Fig Item Rif	Numéro Teil-Nr Numero Part-Nr Part-Nr	Désignation Bezeichnung Descripcion Description Descrizione	Qté-Menge-Cant-Qty-Q.ta																			
			1	2	3	4	5	6	7	8	9	10	11	12	13	14	15	16	17	18	19	20
24	210001	Vis H,M10- 35-10.9-ZN8/C Tornillo Vite	- Schraube - Screw -			8	8	8	8	8	8	8	8									
25	247716	Flexible (Lg 940) Flexible Flessibile	- Schlauch - Hose -			1	1	1	1	1	1	1	1									
26	248190	Flexible (Lg 810) Flexible Flessibile	- Schlauch - Hose -			1	1	1	1	1	1	1	1									
27	247804	Bloc d'alimentation droit Bloque de alimentación derecho- Blocco alimentazione destro	- Recht Zuschiebungblock - R.H. feed block -			1	1	1	1	1	1	1	1									
28	27188	Joint torique Junta tórica Anello OR	- "0" ring - "0" ring -			1	1	1	1	1	1	1	1									
29	247710	Vis H,M12-140-10.9-ZN8/C Tornillo Vite	- Schraube - Screw -			4	4	4	4	4	4	4	4									
30	275245	Clapet anti-retour Válvula antiretorno Valvola anti-ritorno	- Gegendruckventil - Back pressure valve -			1	1	1	1	1	1	1	1									
31	226172	Raccord Racor Raccordo	- Verschraubung - Connection -			1	1	1	1	1	1	1	1									
32	190878	Joint d'étanchéité Junta de estanqueidad Guarnizióne	- Dichtungsring - Seal -			X	X	X	X	X	X	X	X									
33	203240	Raccord Coudé 90° Cranté 16 Racor Raccordo	- Verschraubung - Connection -			2	2	2	2	2	2	2	2									
34	189956	Joint torique Junta tórica Anello OR	- "0" ring - "0" ring -			X	X	X	X	X	X	X	X									

+

Catalogue : 647000

4

CIRCUIT TRANSMISSION HYDROSTATIQUE  
 HYDROSTATIK GETRIEBKREIS  
 CIRCUITO TRANSMISION HIDROSTATICO  
 HYDROSTATIC TRANSMISSION CIRCUIT  
 CIRCUITO TRASMISSIONE IDROSTATICA

Qté-Menge-Cant-Qty-Q.ta

4 AB

182

M

1-	MH20-4T	BUG. S2-E3	11-
2-	MH25-4T	BUG. S2-E3	12-
3-	MSI 20T	S2-E3	13-
4-	MSI 20T	BUG. S2-E3	14-
5-	MSI 25T	S2-E3	15-
6-	MSI 25T	BUG. S2-E3	16-
7-	MSI 30T	S2-E3	17-
8-	MSI 30T	BUG. S2-E3	18-
9-	MSI 35T	S2-E3	19-
10-	MSI 35T	BUG. S2-E3	20-

Rep Hinw Fig Item Rif	Numéro Teil-Nr Numero Part-Nr Part-Nr	Désignation Bezeichnung Description Descrizione	1	2	3	4	5	6	7	8	9	10	11	12	13	14	15	16	17	18	19	20
35	203512	Collier Abrazadera Fascetta - Spannschelle - Clamp -			2	2	2	2	2	2	2	2										
36	230150	Durit (Lg 310) Tubo flexible Manicotto - Schlauch - Hose -			1	1	1	1	1	1	1	1										
37	270375	Pompe hydrostatique Bomba hidrostática Pompa idrostatica - Hydrostatik pumpe - Hydrostatic pump -			1	1	1	1	1	1	1	1										
38	31689	Vis H,M16- 40-10.9-ZN8/C Tornillo Vis - Schraube - Screw -			2	2	2	2	2	2	2	2										
39	77711	Rondelle HR17 x 30x3 ZN Arandela Rondella - Unterlegscheibe - Washer -			2	2	2	2	2	2	2	2										
40	226174	Raccord Racor Raccordo - Verschraubung - Connection -			1	1	1	1	1	1	1	1										
41	248406	Raccord Coudé Cranté Racor Raccordo - Verschraubung - Connection -			1	1	1	1	1	1	1	1										
42	190019	Joint torique Junta tórica Anello OR - "0" ring - "0" ring -			X	X	X	X	X	X	X	X										
43	71940	Collier Abrazadera Fascetta - Spannschelle - Clamp -			2	2	2	2	2	2	2	2										
44	245402	Durit Tubo flexible Manicotto - Schlauch - Hose -			1	1	1	1	1	1	1	1										
45	71940	Collier Abrazadera Fascetta - Spannschelle - Clamp -			2	2	2	2	2	2	2	2										

+



Catalogue : 647000

5	CIRCUIT TRANSMISSION HYDROSTATIQUE HYDROSTATIK GETRIEBKREIS CIRCUITO TRANSMISION HIDROSTATICO HYDROSTATIC TRANSMISSION CIRCUIT CIRCUITO TRASMISSIONE IDROSTATICA			Qté-Menge-Cant-Qty-Q.ta										4 AB		182		M					
	Rep Hinw Fig Item Rif	Numéro Teil-Nr Numero Part-Nr Part-Nr	Désignation Bezeichnung Descripcion Description Descrizione	1	2	3	4	5	6	7	8	9	10	11	12	13	14		15	16	17	18	19
				1- MH20-4T BUG. S2-E3																			
				2- MH25-4T BUG. S2-E3																			
				3- MSI 20T S2-E3																			
				4- MSI 20T BUG. S2-E3																			
				5- MSI 25T S2-E3																			
				6- MSI 25T BUG. S2-E3																			
				7- MSI 30T S2-E3																			
				8- MSI 30T BUG. S2-E3																			
				9- MSI 35T S2-E3																			
				10- MSI 35T BUG. S2-E3																			
46	247722	Durit Tubo flexible Manicotto	- Schlauch - Hose -			1	1	1	1	1	1	1	1										
47	88245	Collier Abrazadera Fascetta	- Spannschelle - Clamp -			1	1	1	1	1	1	1	1										
48	58525	Vis H,M 6- 25-8.8-ZN5/C Tornillo Vite	- Schraube - Screw -			1	1	1	1	1	1	1	1										
49	42316	Rondelle W 6 ZN Arandela Rondella	- Unterlegscheibe - Washer -			1	1	1	1	1	1	1	1										
50	25714	Ecrou H ,M 6 ZN Tuerca Dado	- Mutter - Nut -			1	1	1	1	1	1	1	1										
51	217150	Raccord Coudé 45° Cranté 25 Racor Raccordo	- Verschraubung - Connection -			1	1	1	1	1	1	1	1										
52	247721	Raccord Union Prolongateur Racor Raccordo	- Verschraubung - Connection -			1	1	1	1	1	1	1	1										
53	190875	Joint d'étanchéité Junta de estanqueidad Guarnizióne	- Dichtungsring - Seal -			X	X	X	X	X	X	X	X										
54	248192	Flexible (Lg 940) Flexible Flessibile	- Schlauch - Hose -			1	1	1	1	1	1	1	1										
55	194813	Joint torique Junta tórica Anello OR	- "O" ring - "O" ring -			X	X	X	X	X	X	X	X										
56	202294	Raccord Union Racor Raccordo	- Verschraubung - Connection -			1	1	1	1	1	1	1	1										

Catalogue : 647000

6

CIRCUIT TRANSMISSION HYDROSTATIQUE  
 HYDROSTATIK GETRIEBKREIS  
 CIRCUITO TRANSMISION HIDROSTATICO  
 HYDROSTATIC TRANSMISSION CIRCUIT  
 CIRCUITO TRASMISSIONE IDROSTATICA

Qté-Menge-Cant-Qty-Q.ta

4 AB

182

M

1-	MH20-4T	BUG. S2-E3	11-
2-	MH25-4T	BUG. S2-E3	12-
3-	MSI 20T	S2-E3	13-
4-	MSI 20T	BUG. S2-E3	14-
5-	MSI 25T	S2-E3	15-
6-	MSI 25T	BUG. S2-E3	16-
7-	MSI 30T	S2-E3	17-
8-	MSI 30T	BUG. S2-E3	18-
9-	MSI 35T	S2-E3	19-
10-	MSI 35T	BUG. S2-E3	20-

Rep Hinw Fig Item Rif	Numéro Teil-Nr Numero Part-Nr Part-Nr	Désignation Bezeichnung Description Descrizione	1	2	3	4	5	6	7	8	9	10	11	12	13	14	15	16	17	18	19	20
57	190879	Joint d'étanchéité Junta de estanqueidad Guarnizione - Dichtungsring - Seal -			X	X	X	X	X	X	X	X										
59	248704	Patte Brida Piastra - Auge - Lug -			1	1	1	1	1	1	1	1										
60	63547	Vis H,M12- 30-8.8-ZN8/C Tornillo Vite - Schraube - Screw -			1	1	1	1	1	1	1	1										
61	42231	Rondelle W12 ZN Arandela Rondella - Unterlegscheibe - Washer -			1	1	1	1	1	1	1	1										
62	189852	Raccord Union Racor Raccordo - Verschraubung - Connection -			1	1	1	1	1	1	1	1										
63	169373	Joint torique Junta tórica Anello OR - "0" ring - "0" ring -			X	X	X	X	X	X	X	X										
64	42232	Rondelle W10 ZN Arandela Rondella - Unterlegscheibe - Washer -			4	4	4	4	4	4	4	4										
65	218258	Raccord Coudé Racor Raccordo - Verschraubung - Connection -			1	1	1	1	1	1	1	1										



# 4 AB 183

## CIRCUIT TRANSMISSION HYDROSTATIQUE HYDROSTATIK GETRIEBKREIS CIRCUITO TRANSMISION HIDROSTATICO HYDROSTATIC TRANSMISSION CIRCUIT CIRCUITO TRASMISIONE IDROSTATICO

MSI 20 / 25 / 30 / 35 T S2-E3  
MSI 20 / 25 / 30 / 35 T BUGGIE S2-E3

POUR FLEXIBLE ET RACCORD  
FÜR SCHLAUCH UND VERSCHRAUBUNG  
PARA FLEXIBLE Y RACOR  
FOR HOSE AND CONNECTION  
PER FLESSIBILE E RACCORDO

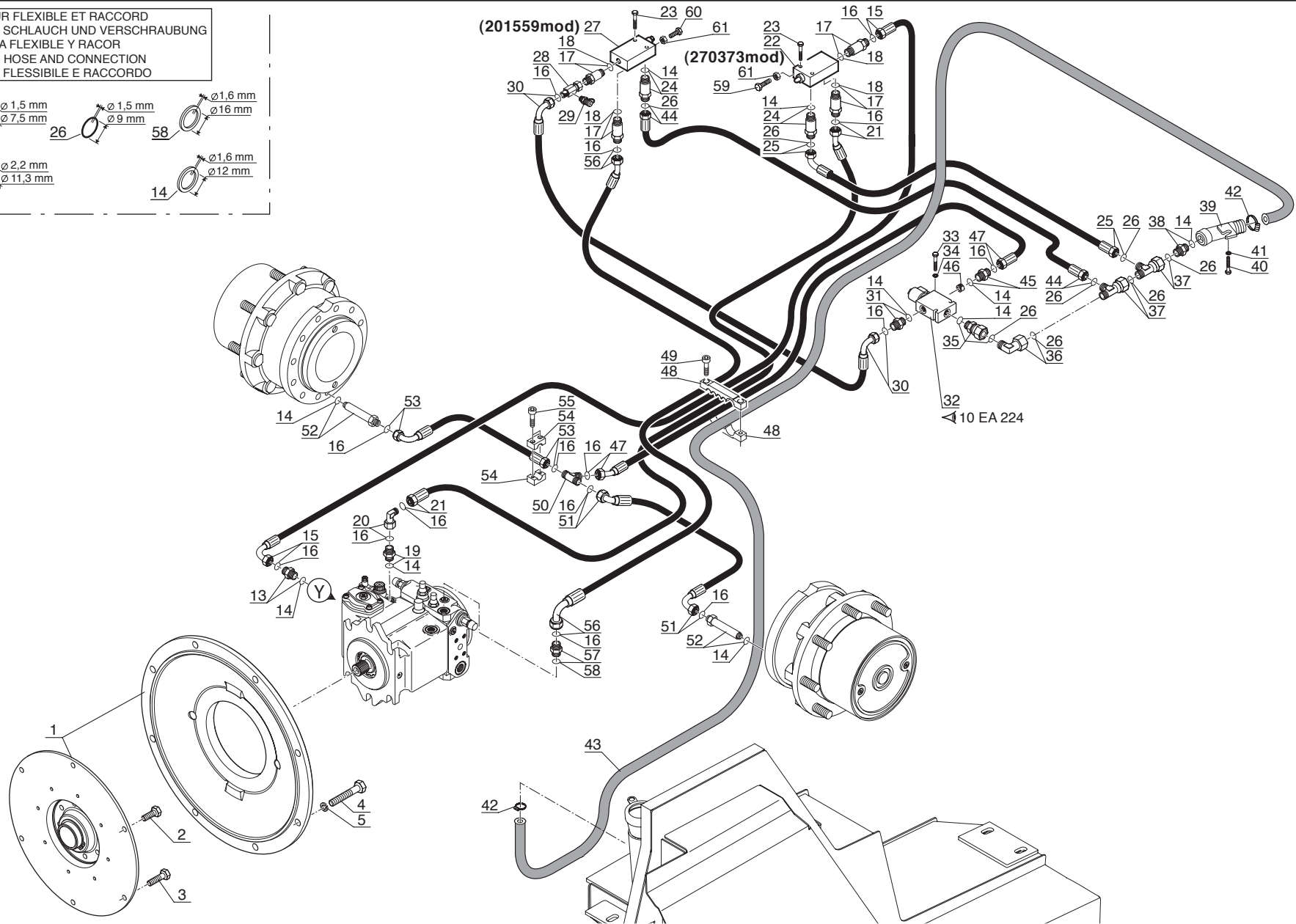
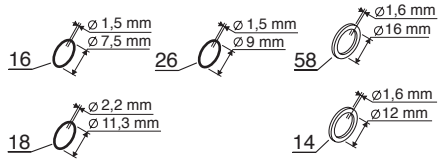

Catalogue : 647000

Qté-Menge-Cant-Qty-Q.ta

4 AB

183

M

1

CIRCUIT TRANSMISSION HYDROSTATIQUE  
 HYDROSTATIK GETRIEBKREIS  
 CIRCUITO TRANSMISION HIDROSTATICO  
 HYDROSTATIC TRANSMISSION CIRCUIT  
 CIRCUITO TRASMISSIONE IDROSTATICA

1-	MH20-4T	BUG. S2-E3	11-
2-	MH25-4T	BUG. S2-E3	12-
3-	MSI 20T	S2-E3	13-
4-	MSI 20T	BUG. S2-E3	14-
5-	MSI 25T	S2-E3	15-
6-	MSI 25T	BUG. S2-E3	16-
7-	MSI 30T	S2-E3	17-
8-	MSI 30T	BUG. S2-E3	18-
9-	MSI 35T	S2-E3	19-
10-	MSI 35T	BUG. S2-E3	20-

Rep Hinw Fig Item Rif	Numéro Teil-Nr Numero Part-Nr Part-Nr	Désignation Bezeichnung Descripcion Description Descrizione	Qté-Menge-Cant-Qty-Q.ta																			
			1	2	3	4	5	6	7	8	9	10	11	12	13	14	15	16	17	18	19	20
1	268793	Accouplement complet Acoplamiento completo Accoppiamento completo	- Kompletter anschluss flansch - Complete coupling piece -			1	1	1	1	1	1	1	1									
2	270164	Vis H,M 8- 12-10.9-ZN8/C Tornillo Vite	- Schraube - Screw -			4	4	4	4	4	4	4	4									
3	270162	Vis H,M 8- 16/16-10.9-ZN8/C Tornillo Vite	- Schraube - Screw -			2	2	2	2	2	2	2	2									
4	5804	Vis H,M10- 25-8.8-ZN8/C Tornillo Vite	- Schraube - Screw -			8	8	8	8	8	8	8	8									
5	42232	Rondelle W10 ZN Arandela Rondella	- Unterlegscheibe - Washer -			8	8	8	8	8	8	8	8									
13	264340	Raccord Union Racor Raccordo	- Verschraubung - Connection -			1	1	1	1	1	1	1	1									
14	177636	Joint d'étanchéité Junta de estanqueidad Guarnizione di tenuta	- Dichtungsring - Seal -			X	X	X	X	X	X	X	X									
15	202304	Flexible Flexible Flessibile	- Schlauch - Hose -			1	1	1	1	1	1	1	1									
16	190020	Joint torique Junta tórica Anello OR	- "0" ring - "0" ring -			X	X	X	X	X	X	X	X									
17	202291	Raccord Union Prolongateur Racor Raccordo	- Verschraubung - Connection -			4	4	4	4	4	4	4	4									
18	177588	Joint torique Junta tórica Anello OR	- "0" ring - "0" ring -			X	X	X	X	X	X	X	X									

+

Catalogue : 647000

2

CIRCUIT TRANSMISSION HYDROSTATIQUE  
 HYDROSTATIK GETRIEBKREIS  
 CIRCUITO TRANSMISION HIDROSTATICO  
 HYDROSTATIC TRANSMISSION CIRCUIT  
 CIRCUITO TRASMISSIONE IDROSTATICA

Qté-Menge-Cant-Qty-Q.ta

4 AB

183

M

1-	MH20-4T	BUG. S2-E3	11-
2-	MH25-4T	BUG. S2-E3	12-
3-	MSI 20T	S2-E3	13-
4-	MSI 20T	BUG. S2-E3	14-
5-	MSI 25T	S2-E3	15-
6-	MSI 25T	BUG. S2-E3	16-
7-	MSI 30T	S2-E3	17-
8-	MSI 30T	BUG. S2-E3	18-
9-	MSI 35T	S2-E3	19-
10-	MSI 35T	BUG. S2-E3	20-

Rep Hinw Fig Item Rif	Número Teil-Nr Numero Part-Nr Part-Nr	Désignation Bezeichnung Description Descrizione	1	2	3	4	5	6	7	8	9	10	11	12	13	14	15	16	17	18	19	20
19	182810	Raccord Racor Raccordo - Verschraubung - Connection -			1	1	1	1	1	1	1	1										
20	497920	Raccord Coudé Adapteur Racor Raccordo - Verschraubung - Connection -			1	1	1	1	1	1	1	1										
21	248191	Flexible (Lg 1820) Flexible Flessibile - Schlauch - Hose -			1	1	1	1	1	1	1	1										
22	270373	Réducteur de pression complet Valvulá de inching completa Riduttore di pressione completo - Komplette inching ventil - Complete inching valve			1	1	1	1	1	1	1	1										
23	6224	Vis H,M 8- 40-8.8-ZN8/C Tornillo Vite - Schraube - Screw -			4	4	4	4	4	4	4	4										
24	202292	Raccord Union Prolongateur Racor Raccordo - Verschraubung - Connection -			2	2	2	2	2	2	2	2										
25	202306	Flexible Flexible Flessibile - Schlauch - Hose -			1	1	1	1	1	1	1	1										
26	190874	Joint torique Junta tórica Anello OR - "0" ring - "0" ring -			X	X	X	X	X	X	X	X										
27	201559	Réducteur de pression complet Valvulá de inching completa Riduttore di pressione completo - Komplette inching ventil - Complete inching valve			1	1	1	1	1	1	1	1										
28	58183	Raccord AD FE 10L/ MA 10L MODIFIE Verschraubung Racor Raccordo - Connection -			1	1	1	1	1	1	1	1										
29	58181	Prise de pression Toma de presión Presa pressione - Drückdöse - Pressure test -			1	1	1	1	1	1	1	1										

+

Catalogue : 647000

3

CIRCUIT TRANSMISSION HYDROSTATIQUE  
 HYDROSTATIK GETRIEBKREIS  
 CIRCUITO TRANSMISION HIDROSTATICO  
 HYDROSTATIC TRANSMISSION CIRCUIT  
 CIRCUITO TRASMISSIONE IDROSTATICA

Qté-Menge-Cant-Qty-Q.ta

4 AB

183

M

1-	MH20-4T	BUG. S2-E3	11-
2-	MH25-4T	BUG. S2-E3	12-
3-	MSI 20T	S2-E3	13-
4-	MSI 20T	BUG. S2-E3	14-
5-	MSI 25T	S2-E3	15-
6-	MSI 25T	BUG. S2-E3	16-
7-	MSI 30T	S2-E3	17-
8-	MSI 30T	BUG. S2-E3	18-
9-	MSI 35T	S2-E3	19-
10-	MSI 35T	BUG. S2-E3	20-

Rep Hinw Fig Item Rif	Numéro Teil-Nr Numero Part-Nr Part-Nr	Désignation Bezeichnung Descripcion Description Descrizione	Qté-Menge-Cant-Qty-Q.ta																			
			1	2	3	4	5	6	7	8	9	10	11	12	13	14	15	16	17	18	19	20
30	202309	Flexible Flexible Flessibile - Schlauch - Hose -			1	1	1	1	1	1	1	1	1									
31	202288	Raccord Union Racor Raccordo - Verschraubung - Connection -			1	1	1	1	1	1	1	1	1									
32	202243	Electrovalve complète Electroválvula completa Electrovalvola completa - Kompletter elektroventil - Complete electrovalve -			1	1	1	1	1	1	1	1	1									
33	58526	Vis H,M 6- 40-8.8-ZN5/C Tornillo Vite - Schraube - Screw -			2	2	2	2	2	2	2	2	2									
34	29469	Rondelle M 6 ZN Arandela Rondella - Unterlegscheibe - Washer -			2	2	2	2	2	2	2	2	2									
35	498298	Raccord AD FE 12L OR/ MA 1/4" BSP JE Verschraubung Racor Raccordo - Connection -			1	1	1	1	1	1	1	1	1									
36	215632	Raccord Coudé 90° Adapteur Racor Raccordo - Verschraubung - Connection -			1	1	1	1	1	1	1	1	1									
37	204343	Raccord Té Adapteur Racor Raccordo - Verschraubung - Connection -			2	2	2	2	2	2	2	2	2									
38	202293	Raccord Union Racor Raccordo - Verschraubung - Connection -			1	1	1	1	1	1	1	1	1									
39	217113	Tube Tubo Tubo - Rohr - Tube -			1	1	1	1	1	1	1	1	1									
40	25713	Vis H,M 6- 16-8.8-ZN5/C Tornillo Vite - Schraube - Screw -			1	1	1	1	1	1	1	1	1									

+





Catalogue : 647000

5

CIRCUIT TRANSMISSION HYDROSTATIQUE  
 HYDROSTATIK GETRIEBKREIS  
 CIRCUITO TRANSMISION HIDROSTATICO  
 HYDROSTATIC TRANSMISSION CIRCUIT  
 CIRCUITO TRASMISSIONE IDROSTATICA

Qté-Menge-Cant-Qty-Q.ta

4 AB

183

M

1-	MH20-4T	BUG. S2-E3	11-
2-	MH25-4T	BUG. S2-E3	12-
3-	MSI 20T	S2-E3	13-
4-	MSI 20T	BUG. S2-E3	14-
5-	MSI 25T	S2-E3	15-
6-	MSI 25T	BUG. S2-E3	16-
7-	MSI 30T	S2-E3	17-
8-	MSI 30T	BUG. S2-E3	18-
9-	MSI 35T	S2-E3	19-
10-	MSI 35T	BUG. S2-E3	20-

Rep Hinw Fig Item Rif	Numéro Teil-Nr Numero Part-Nr Part-Nr	Désignation Bezeichnung Descripcion Description Descrizione	Qté-Menge-Cant-Qty-Q.ta																			
			1	2	3	4	5	6	7	8	9	10	11	12	13	14	15	16	17	18	19	20
52	208566	Raccord Union Prolongateur Racor Raccordo - Verschraubung - Connection -			2	2	2	2	2	2	2	2	2									
53	202310	Flexible (Lg 550) Flexible Flessibile - Schlauch - Hose -			1	1	1	1	1	1	1	1	1									
54	172914	Demi-collier Media abrazadera Fascetta - Halb-klemme - Half-clamp -			2	2	2	2	2	2	2	2	2									
55	167155	Vis CHc,M 6- 25 zinguée Tornillo Vite - Schraube - Screw -			2	2	2	2	2	2	2	2	2									
56	218252	Flexible Flexible Flessibile - Schlauch - Hose -			1	1	1	1	1	1	1	1	1									
57	202289	Raccord Union Racor Raccordo - Verschraubung - Connection -			1	1	1	1	1	1	1	1	1									
58	177637	Joint d'étanchéité Junta de estanqueidad Guarnizione - Dichtungsring - Seal -			X	X	X	X	X	X	X	X	X									
59	168343	Vis H,M 6- 30-8.8-ZN5/C Tornillo Vite - Schraube - Screw -			1	1	1	1	1	1	1	1	1									
60	25713	Vis H,M 6- 16-8.8-ZN5/C Tornillo Vite - Schraube - Screw -			1	1	1	1	1	1	1	1	1									
61	29477	Ecrou Hm, M 6 zingué Tuerca Dado - Mutter - Nut -			2	2	2	2	2	2	2	2	2									

# 4 AB 184

## CIRCUIT TRANSMISSION HYDROSTATIQUE HYDROSTATIK GETRIEBKREIS CIRCUITO TRANSMISION HIDROSTATICO HYDROSTATIC TRANSMISSION CIRCUIT CIRCUITO TRASMISONE IDROSTATICO

MH 20-4 T BUGGIE S2-E3  
MH 25-4 T BUGGIE S2-E3

POUR FLEXIBLE ET RACCORD  
FÜR SCHLAUCH UND VERSCHRAUBUNG  
PARA FLEXIBLE Y RACOR  
FOR HOSE AND CONNECTION  
PER FLESSIBILE E RACCORDO

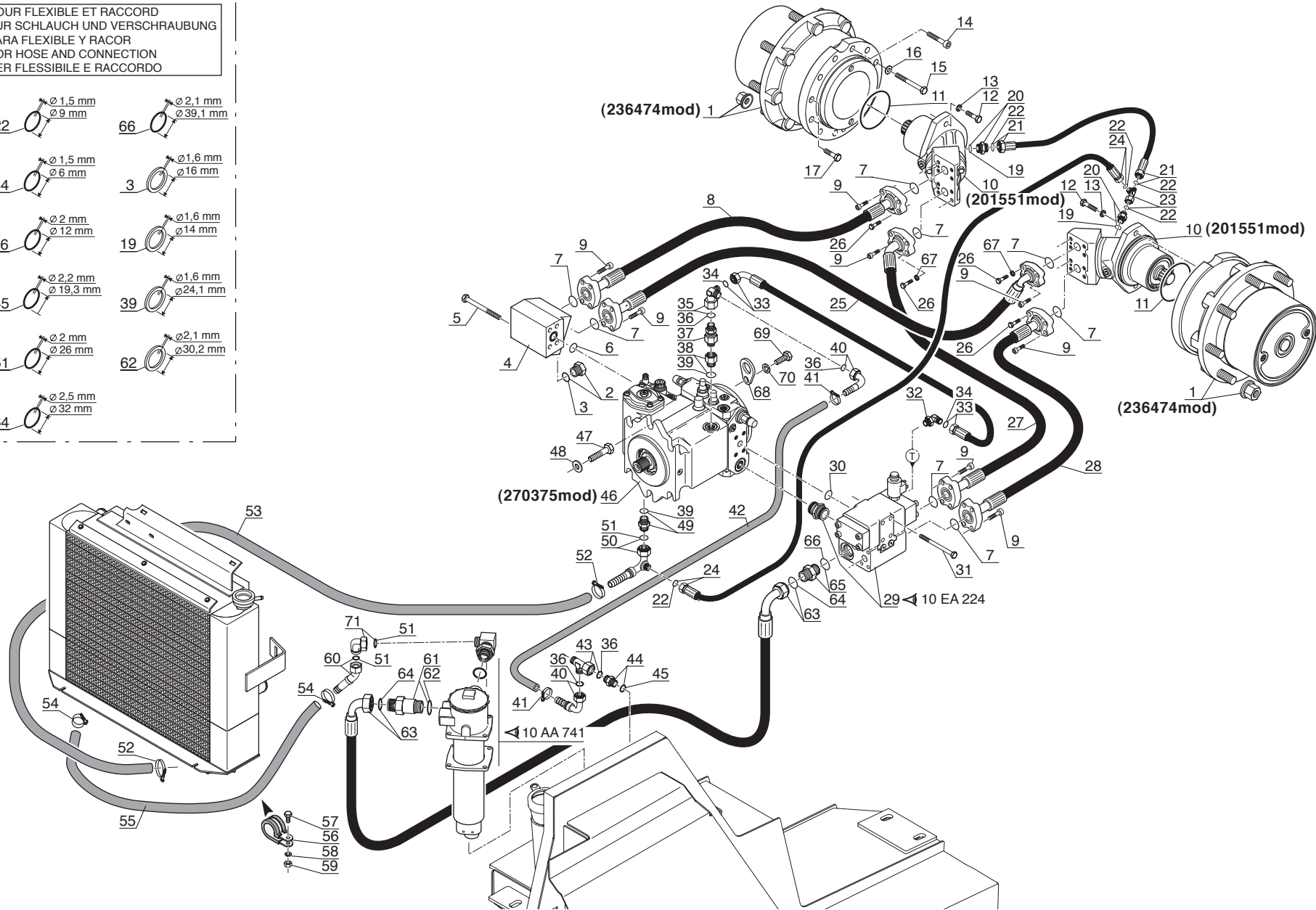
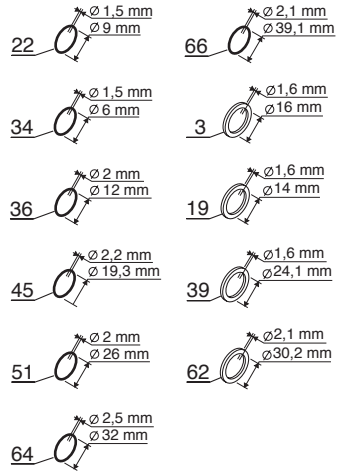

Catalogue : 647000

Qté-Menge-Cant-Qty-Q.ta

4 AB

184

M

1

CIRCUIT TRANSMISSION HYDROSTATIQUE  
 HYDROSTATIK GETRIEBKREIS  
 CIRCUITO TRANSMISION HIDROSTATICO  
 HYDROSTATIC TRANSMISSION CIRCUIT  
 CIRCUITO TRASMISSIONE IDROSTATICA

1- MH20-4T BUG. S2-E3 11-  
 2- MH25-4T BUG. S2-E3 12-  
 3- MSI 20T S2-E3 13-  
 4- MSI 20T BUG. S2-E3 14-  
 5- MSI 25T S2-E3 15-  
 6- MSI 25T BUG. S2-E3 16-  
 7- MSI 30T S2-E3 17-  
 8- MSI 30T BUG. S2-E3 18-  
 9- MSI 35T S2-E3 19-  
 10- MSI 35T BUG. S2-E3 20-

Rep Hinw Fig Item Rif	Numéro Teil-Nr Numero Part-Nr Part-Nr	Désignation Bezeichnung Descripcion Description Descrizione	1	2	3	4	5	6	7	8	9	10	11	12	13	14	15	16	17	18	19	20
1	236474	Réducteur de roue - Rad reduktion Reductor de rueda - Wheel reducing Riduttore di ruota -	2	2																		
2	217086	Raccord bouchon - Verschraubung Racor - Connection Raccordo -	1	1																		
3	177637	Joint d'étanchéité - Dichtungsring Junta de estanqueidad - Seal Guarnizione -	X	X																		
4	247703	Bloc d'alimentation gauche - Link Zuschiebungblock Bloque de alimentación izquierdo L.H. feed block Blocco alimentazione sinistro -	1	1																		
5	247710	Vis H,M12-140-10.9-ZN8/C - Schraube Tornillo - Screw Vite -	4	4																		
6	27188	Joint torique - "0" ring Junta tórica - "0" ring Anello OR -	1	1																		
7	85822	Joint torique - "0" ring Junta tórica - "0" ring Anello OR -	8	8																		
8	247717	Flexible (Lg 810) - Schlauch Flexible - Hose Flessibile -	1	1																		
9	202250	Vis CHc,M10- 35 zinguée - Schraube Tornillo - Screw Vite -	24	24																		
10	201551	Moteur hydrostatique complet - Kompletter hydrostatik motor Motor hidrostático completo - Complete hydrostatic motor Motore idrostatico completo -	2	2																		
11	203510	Joint torique - "0" ring Junta tórica - "0" ring Anello OR -	2	2																		

+



Catalogue : 647000

3	CIRCUIT TRANSMISSION HYDROSTATIQUE HYDROSTATIK GETRIEBKREIS CIRCUITO TRANSMISION HIDROSTATICO HYDROSTATIC TRANSMISSION CIRCUIT CIRCUITO TRASMISSIONE IDROSTATICA			Qté-Menge-Cant-Qty-Q.ta										4 AB		184		M					
	Rep Hinw Fig Item Rif	Numéro Teil-Nr Numero Part-Nr Part-Nr	Désignation Bezeichnung Descripcion Description Descrizione	1	2	3	4	5	6	7	8	9	10	11	12	13	14		15	16	17	18	19
24	169037	Flexible (Lg 1350) Flexible Flessibile	- Schlauch - Hose -	1	1																		
25	247716	Flexible (Lg 940) Flexible Flessibile	- Schlauch - Hose -	1	1																		
26	210001	Vis H,M10- 35-10.9-ZN8/C Tornillo Vite	- Schraube - Screw -	8	8																		
27	247715	Flexible (Lg 900) Flexible Flessibile	- Schlauch - Hose -	1	1																		
28	247717	Flexible (Lg 810) Flexible Flessibile	- Schlauch - Hose -	1	1																		
29	247704	Bloc d'alimentation droit Bloque de alimentación derecho- Blocco alimentazione destro	- Recht Zuschiebungblock - R.H. feed block -	1	1																		
30	27188	Joint torique Junta tórica Anello OR	- "0" ring - "0" ring -	1	1																		
31	247710	Vis H,M12-140-10.9-ZN8/C Tornillo Vite	- Schraube - Screw -	4	4																		
32	225521	Raccord Coudé Racor Raccordo	- Verschraubung - Connection -	1	1																		
33	216652	Flexible Flexible Flessibile	- Schlauch - Hose -	1	1																		
34	190013	Joint torique Junta tórica Anello OR	- "0" ring - "0" ring -	X	X																		

+

Catalogue : 647000

4

CIRCUIT TRANSMISSION HYDROSTATIQUE  
 HYDROSTATIK GETRIEBKREIS  
 CIRCUITO TRANSMISION HIDROSTATICO  
 HYDROSTATIC TRANSMISSION CIRCUIT  
 CIRCUITO TRASMISSIONE IDROSTATICA

Qté-Menge-Cant-Qty-Q.ta

4 AB

184

M

1-	MH20-4T	BUG. S2-E3	11-
2-	MH25-4T	BUG. S2-E3	12-
3-	MSI 20T	S2-E3	13-
4-	MSI 20T	BUG. S2-E3	14-
5-	MSI 25T	S2-E3	15-
6-	MSI 25T	BUG. S2-E3	16-
7-	MSI 30T	S2-E3	17-
8-	MSI 30T	BUG. S2-E3	18-
9-	MSI 35T	S2-E3	19-
10-	MSI 35T	BUG. S2-E3	20-

Rep Hinw Fig Item Rif	Numéro Teil-Nr Numero Part-Nr Part-Nr	Désignation Bezeichnung Descripcion Description Descrizione	1	2	3	4	5	6	7	8	9	10	11	12	13	14	15	16	17	18	19	20
35	238705	Raccord Coudé Adapteur Racor Raccordo - Verschraubung - Connection -	1	1																		
36	189956	Joint torique Junta tórica Anello OR - "0" ring - "0" ring -	X	X																		
37	275245	Clapet anti-retour Válvula antiretorno Valvola anti-ritorno - Gegendruckventil - Back pressure valve -	1	1																		
38	226172	Raccord Racor Raccordo - Verschraubung - Connection -	1	1																		
39	190878	Joint d'étanchéité Junta de estanqueidad Guarnizióne - Dichtungsring - Seal -	X	X																		
40	203240	Raccord Coudé 90° Cranté 16 Racor Raccordo - Verschraubung - Connection -	2	2																		
41	203512	Collier Abrazadera Fascetta - Spannschelle - Clamp -	2	2																		
42	179275	Durit Tubo flexible Manicotto - Schlauch - Hose -	1	1																		
43	228216	Raccord Té Racor Raccordo - Verschraubung - Connection -	1	1																		
44	189852	Raccord Union Racor Raccordo - Verschraubung - Connection -	1	1																		
45	169373	Joint torique Junta tórica Anello OR - "0" ring - "0" ring -	X	X																		

+

Catalogue : 647000

5

CIRCUIT TRANSMISSION HYDROSTATIQUE  
 HYDROSTATIK GETRIEBKREIS  
 CIRCUITO TRANSMISION HIDROSTATICO  
 HYDROSTATIC TRANSMISSION CIRCUIT  
 CIRCUITO TRASMISSIONE IDROSTATICA

Qté-Menge-Cant-Qty-Q.ta

4 AB

184

M

1-	MH20-4T	BUG. S2-E3	11-
2-	MH25-4T	BUG. S2-E3	12-
3-	MSI 20T	S2-E3	13-
4-	MSI 20T	BUG. S2-E3	14-
5-	MSI 25T	S2-E3	15-
6-	MSI 25T	BUG. S2-E3	16-
7-	MSI 30T	S2-E3	17-
8-	MSI 30T	BUG. S2-E3	18-
9-	MSI 35T	S2-E3	19-
10-	MSI 35T	BUG. S2-E3	20-

Rep Hinw Fig Item Rif	Numéro Teil-Nr Numero Part-Nr Part-Nr	Désignation Bezeichnung Descripcion Description Descrizione	1	2	3	4	5	6	7	8	9	10	11	12	13	14	15	16	17	18	19	20
46	270375	Pompe hydrostatique Bomba hidrostática Pompa idrostatica - Hydrostatik pumpe - Hydrostatic pump -	1	1																		
47	31689	Vis H,M16- 40-10.9-ZN8/C Tornillo Vis - Schraube - Screw -	2	2																		
48	77711	Rondelle HR17 x 30x3 ZN Arandela Rondella - Unterlegscheibe - Washer -	2	2																		
49	226174	Raccord Racor Raccordo - Verschraubung - Connection -	1	1																		
50	248406	Raccord Coudé Cranté Racor Raccordo - Verschraubung - Connection -	1	1																		
51	190019	Joint torique Junta tórica Anello OR - "0" ring - "0" ring -	X	X																		
52	71940	Collier Abrazadera Fascetta - Spannschelle - Clamp -	2	2																		
53	245402	Durit Tubo flexible Manicotto - Schlauch - Hose -	1	1																		
54	71940	Collier Abrazadera Fascetta - Spannschelle - Clamp -	2	2																		
55	247722	Durit Tubo flexible Manicotto - Schlauch - Hose -	1	1																		
56	88245	Collier Abrazadera Fascetta - Spannschelle - Clamp -	1	1																		

+

Catalogue : 647000

6	CIRCUIT TRANSMISSION HYDROSTATIQUE HYDROSTATIK GETRIEBKREIS CIRCUITO TRANSMISION HIDROSTATICO HYDROSTATIC TRANSMISSION CIRCUIT CIRCUITO TRASMISSIONE IDROSTATICA			Qté-Menge-Cant-Qty-Q.ta										4 AB		184		M					
	Rep Hinw Fig Item Rif	Numéro Teil-Nr Numero Part-Nr Part-Nr	Désignation Bezeichnung Descripcion Description Descrizione	1	2	3	4	5	6	7	8	9	10	11	12	13	14	15	16	17	18	19	20
57	58525	Vis H,M 6- 25-8.8-ZN5/C Tornillo Vite	- Schraube - Screw -	1	1																		
58	42316	Rondelle W 6 ZN Arandela Rondella	- Unterlegscheibe - Washer -	1	1																		
59	25714	Ecrou H ,M 6 ZN Tuerca Dado	- Mutter - Nut -	1	1																		
60	217150	Raccord Coudé 45° Cranté 25 Racor Raccordo	- Verschraubung - Connection -	1	1																		
61	247721	Raccord Union Prolongateur Racor Raccordo	- Verschraubung - Connection -	1	1																		
62	190875	Joint d'étanchéité Junta de estanqueidad Guarnizióne	- Dichtungsring - Seal -	X	X																		
63	247720	Flexible (Lg 960) Flexible Flessibile	- Schlauch - Hose -	1	1																		
64	194813	Joint torique Junta tórica Anello OR	- "O" ring - "O" ring -	X	X																		
65	202294	Raccord Union Racor Raccordo	- Verschraubung - Connection -	1	1																		
66	190879	Joint d'étanchéité Junta de estanqueidad Guarnizióne	- Dichtungsring - Seal -	X	X																		
67	42232	Rondelle W10 ZN Arandela Rondella	- Unterlegscheibe - Washer -	4	4																		

+



Catalogue : 647000

7

CIRCUIT TRANSMISSION HYDROSTATIQUE  
 HYDROSTATIK GETRIEBKREIS  
 CIRCUITO TRANSMISION HIDROSTATICO  
 HYDROSTATIC TRANSMISSION CIRCUIT  
 CIRCUITO TRASMISSIONE IDROSTATICA

Qté-Menge-Cant-Qty-Q.ta

4 AB

184

M

1-	MH20-4T	BUG. S2-E3	11-
2-	MH25-4T	BUG. S2-E3	12-
3-	MSI 20T	S2-E3	13-
4-	MSI 20T	BUG. S2-E3	14-
5-	MSI 25T	S2-E3	15-
6-	MSI 25T	BUG. S2-E3	16-
7-	MSI 30T	S2-E3	17-
8-	MSI 30T	BUG. S2-E3	18-
9-	MSI 35T	S2-E3	19-
10-	MSI 35T	BUG. S2-E3	20-

Rep Hinw Fig Item Rif	Numéro Teil-Nr Numero Part-Nr Part-Nr	Désignation Bezeichnung Descripcion Description Descrizione
68	248704	Patte - Auge Brida - Lug Piastra -
69	63547	Vis H,M12- 30-8.8-ZN8/C - Schraube Tornillo - Screw Vite -
70	42231	Rondelle W12 ZN - Unterlegscheibe Arandela - Washer Rondella -
71	218258	Raccord Coudé - Verschraubung Racor - Connection Raccordo -

1	2	3	4	5	6	7	8	9	10	11	12	13	14	15	16	17	18	19	20
1	1																		
1	1																		
1	1																		
1	1																		

# 4 AB 185

## CIRCUIT TRANSMISSION HYDROSTATIQUE HYDROSTATIK GETRIEBKREIS CIRCUITO TRANSMISION HIDROSTATICO HYDROSTATIC TRANSMISSION CIRCUIT CIRCUITO TRASMISONE IDROSTATICO

MH 20-4 T BUGGIE S2-E3  
 MH 25-4 T BUGGIE S2-E3

POUR FLEXIBLE ET RACCORD  
 FÜR SCHLAUCH UND VERSCHRAUBUNG  
 PARA FLEXIBLE Y RACOR  
 FOR HOSE AND CONNECTION  
 PER FLESSIBILE E RACCORDO

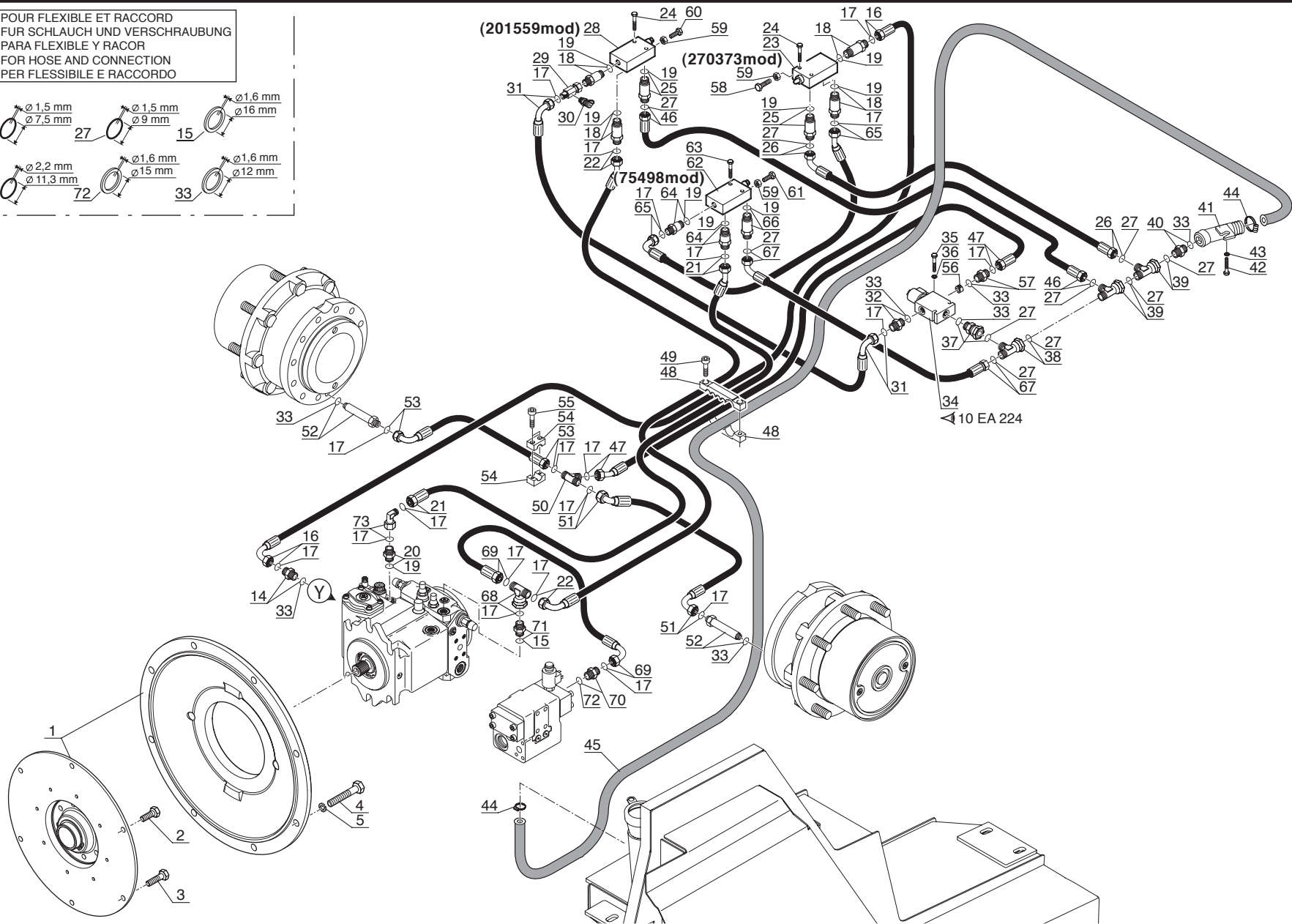
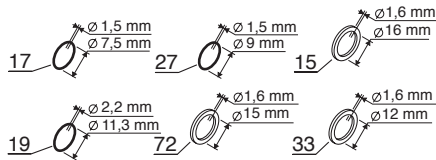

Catalogue : 647000

Qté-Menge-Cant-Qty-Q.ta

4 AB

185

M

1

CIRCUIT TRANSMISSION HYDROSTATIQUE  
 HYDROSTATIK GETRIEBKREIS  
 CIRCUITO TRANSMISION HIDROSTATICO  
 HYDROSTATIC TRANSMISSION CIRCUIT  
 CIRCUITO TRASMISSIONE IDROSTATICA

1- MH20-4T BUG. S2-E3 11-  
 2- MH25-4T BUG. S2-E3 12-  
 3- MSI 20T S2-E3 13-  
 4- MSI 20T BUG. S2-E3 14-  
 5- MSI 25T S2-E3 15-  
 6- MSI 25T BUG. S2-E3 16-  
 7- MSI 30T S2-E3 17-  
 8- MSI 30T BUG. S2-E3 18-  
 9- MSI 35T S2-E3 19-  
 10- MSI 35T BUG. S2-E3 20-

Rep Hinw Fig Item Rif	Número Teil-Nr Numero Part-Nr Part-Nr	Désignation Bezeichnung Descripcion Description Descrizione	1	2	3	4	5	6	7	8	9	10	11	12	13	14	15	16	17	18	19	20
1	268793	Accouplement complet Acoplamiento completo Accoppiamento completo - Kompletter anschluss flansch - Complete coupling piece -	1	1																		
2	270164	Vis H,M 8- 12-10.9-ZN8/C Tornillo Vite - Schraube - Screw -	4	4																		
3	270162	Vis H,M 8- 16/16-10.9-ZN8/C Tornillo Vite - Schraube - Screw -	2	2																		
4	5804	Vis H,M10- 25-8.8-ZN8/C Tornillo Vite - Schraube - Screw -	8	8																		
5	42232	Rondelle W10 ZN Arandela Rondella - Unterlegscheibe - Washer -	8	8																		
14	264340	Raccord Union Racor Raccordo - Verschraubung - Connection -	1	1																		
15	177637	Joint d'étanchéité Junta de estanqueidad Guarnizione - Dichtungsring - Seal -	X	X																		
16	202304	Flexible Flexible Flessibile - Schlauch - Hose -	1	1																		
17	190020	Joint torique Junta tórica Anello OR - "0" ring - "0" ring -	X	X																		
18	202291	Raccord Union Prolongateur Racor Raccordo - Verschraubung - Connection -	4	4																		
19	177588	Joint torique Junta tórica Anello OR - "0" ring - "0" ring -	X	X																		

+

Catalogue : 647000

2

CIRCUIT TRANSMISSION HYDROSTATIQUE  
 HYDROSTATIK GETRIEBKREIS  
 CIRCUITO TRANSMISION HIDROSTATICO  
 HYDROSTATIC TRANSMISSION CIRCUIT  
 CIRCUITO TRASMISSIONE IDROSTATICA

Qté-Menge-Cant-Qty-Q.ta

4 AB

185

M

1-	MH20-4T	BUG. S2-E3	11-
2-	MH25-4T	BUG. S2-E3	12-
3-	MSI 20T	S2-E3	13-
4-	MSI 20T	BUG. S2-E3	14-
5-	MSI 25T	S2-E3	15-
6-	MSI 25T	BUG. S2-E3	16-
7-	MSI 30T	S2-E3	17-
8-	MSI 30T	BUG. S2-E3	18-
9-	MSI 35T	S2-E3	19-
10-	MSI 35T	BUG. S2-E3	20-

Rep Hinw Fig Item Rif	Numéro Teil-Nr Numero Part-Nr Part-Nr	Désignation Bezeichnung Descripcion Description Descrizione	1	2	3	4	5	6	7	8	9	10	11	12	13	14	15	16	17	18	19	20
20	182810	Raccord Racor Raccordo - Verschraubung - Connection -	1	1																		
21	247718	Flexible (Lg 2050) Flexible Flessibile - Schlauch - Hose -	1	1																		
22	218252	Flexible Flexible Flessibile - Schlauch - Hose -	1	1																		
23	270373	Réducteur de pression complet Valvulá de inching completa Riduttore di pressione completo - Komplette inching ventil - Complete inching valve -	1	1																		
24	6224	Vis H,M 8- 40-8.8-ZN8/C Tornillo Vite - Schraube - Screw -	4	4																		
25	202292	Raccord Union Prolongateur Racor Raccordo - Verschraubung - Connection -	2	2																		
26	202306	Flexible Flexible Flessibile - Schlauch - Hose -	1	1																		
27	190874	Joint torique Junta tórica Anello OR - "0" ring - "0" ring -	X	X																		
28	201559	Réducteur de pression complet Valvulá de inching completa Riduttore di pressione completo - Komplette inching ventil - Complete inching valve -	1	1																		
29	58183	Raccord AD FE 10L/ MA 10L MODIFIE Verschraubung Racor Raccordo - Connection -	1	1																		
30	58181	Prise de pression Toma de presión Presa pressione - Drückdöse - Pressure test -	1	1																		

+

Catalogue : 647000

3	CIRCUIT TRANSMISSION HYDROSTATIQUE HYDROSTATIK GETRIEBKREIS CIRCUITO TRANSMISION HIDROSTATICO HYDROSTATIC TRANSMISSION CIRCUIT CIRCUITO TRASMISSIONE IDROSTATICA			Qté-Menge-Cant-Qty-Q.ta										4 AB		185		M					
	Rep Hinw Fig Item Rif	Numéro Teil-Nr Numero Part-Nr Part-Nr	Désignation Bezeichnung Description Descrizione	1	2	3	4	5	6	7	8	9	10	11	12	13	14	15	16	17	18	19	20
				1-	MH20-4T	BUG.	S2-E3	11-															
				2-	MH25-4T	BUG.	S2-E3	12-															
				3-	MSI 20T	S2-E3		13-															
				4-	MSI 20T	BUG.	S2-E3	14-															
				5-	MSI 25T	S2-E3		15-															
				6-	MSI 25T	BUG.	S2-E3	16-															
				7-	MSI 30T	S2-E3		17-															
				8-	MSI 30T	BUG.	S2-E3	18-															
				9-	MSI 35T	S2-E3		19-															
				10-	MSI 35T	BUG.	S2-E3	20-															
31	202309	Flexible Flexible Flessibile	- Schlauch - Hose -	1	1																		
32	202288	Raccord Union Racor Raccordo	- Verschraubung - Connection -	1	1																		
33	177636	Joint d'étanchéité Junta de estanqueidad Guarnizione di tenuta	- Dichtungsring - Seal -	X	X																		
34	202243	Electrovalve complète Electroválvula completa Electrovalvola completa	- Kompletter elektroventil - Complete electrovalve -	1	1																		
35	58526	Vis H,M 6- 40-8.8-ZN5/C Tornillo Vite	- Schraube - Screw -	2	2																		
36	29469	Rondelle M 6 ZN Arandela Rondella	- Unterlegscheibe - Washer -	2	2																		
37	498298	Raccord AD FE 12L OR/ MA 1/4" BSP JE Verschraubung Racor Raccordo	- Connection -	1	1																		
38	204343	Raccord Té Adapteur Racor Raccordo	- Verschraubung - Connection -	1	1																		
39	204343	Raccord Té Adapteur Racor Raccordo	- Verschraubung - Connection -	2	2																		
40	202293	Raccord Union Racor Raccordo	- Verschraubung - Connection -	1	1																		
41	217113	Tube Tubo Tubo	- Rohr - Tube -	1	1																		

Catalogue : 647000

4

CIRCUIT TRANSMISSION HYDROSTATIQUE  
 HYDROSTATIK GETRIEBKREIS  
 CIRCUITO TRANSMISION HIDROSTATICO  
 HYDROSTATIC TRANSMISSION CIRCUIT  
 CIRCUITO TRASMISSIONE IDROSTATICA

Qté-Menge-Cant-Qty-Q.ta

4 AB

185

M

1-	MH20-4T	BUG. S2-E3	11-
2-	MH25-4T	BUG. S2-E3	12-
3-	MSI 20T	S2-E3	13-
4-	MSI 20T	BUG. S2-E3	14-
5-	MSI 25T	S2-E3	15-
6-	MSI 25T	BUG. S2-E3	16-
7-	MSI 30T	S2-E3	17-
8-	MSI 30T	BUG. S2-E3	18-
9-	MSI 35T	S2-E3	19-
10-	MSI 35T	BUG. S2-E3	20-

Rep Hinw Fig Item Rif	Numéro Teil-Nr Numero Part-Nr Part-Nr	Désignation Bezeichnung Descripcion Description Descrizione	1	2	3	4	5	6	7	8	9	10	11	12	13	14	15	16	17	18	19	20	
42	25713	Vis H,M 6- 16-8.8-ZN5/C Tornillo Vite	- Schraube - Screw -	1	1																		
43	459749	Rondelle L 6 ZN Arandela Rondella	- Unterlegscheibe - Washer -	1	1																		
44	33593	Collier Abrazadera Fascetta	- Spannschelle - Clamp -	2	2																		
45	71577	Durit Tubo flexible Manicotto	- Schlauch - Hose -	1	1																		
46	217104	Flexible Flexible Flessibile	- Schlauch - Hose -	1	1																		
47	202303	Flexible Flexible Flessibile	- Schlauch - Hose -	1	1																		
48	209578	Bride de fixation Brida de fijación Flangia di fissaggio	- Befestigung Klammer - Fastening flange -	2	2																		
49	26957	Vis CHc,M 8- 35 zinguée Tornillo Vite	- Schraube - Screw -	2	2																		
50	202290	Raccord Té Racor Raccordo	- Verschraubung - Connection -	1	1																		
51	208567	Flexible Flexible Flessibile	- Schlauch - Hose -	1	1																		
52	208566	Raccord Union Prolongateur Racor Raccordo	- Verschraubung - Connection -	2	2																		

+

Catalogue : 647000

5	CIRCUIT TRANSMISSION HYDROSTATIQUE HYDROSTATIK GETRIEBKREIS CIRCUITO TRANSMISION HIDROSTATICO HYDROSTATIC TRANSMISSION CIRCUIT CIRCUITO TRASMISSIONE IDROSTATICA			Qté-Menge-Cant-Qty-Q.ta										4 AB		185		M					
	Rep Hinw Fig Item Rif	Número Teil-Nr Numero Part-Nr Part-Nr	Désignation Bezeichnung Descripcion Description Descrizione	1	2	3	4	5	6	7	8	9	10	11	12	13	14		15	16	17	18	19
53	202310	Flexible (Lg 550) Flexible Flessibile	- Schlauch - Hose -	1	1																		
54	172914	Demi-collier Media abrazadera Fascetta	- Halb-klemme - Half-clamp -	2	2																		
55	167155	Vis CHc,M 6- 25 zinguée Tornillo Vite	- Schraube - Screw -	2	2																		
56	217968	Filtre Filtro Filtro	- Filter - Filter -	1	1																		
57	217969	Raccord Union Racor Raccordo	- Verschraubung - Connection -	1	1																		
58	168343	Vis H,M 6- 30-8.8-ZN5/C Tornillo Vite	- Schraube - Screw -	1	1																		
59	29477	Ecrou Hm, M 6 zingué Tuerca Dado	- Mutter - Nut -	3	3																		
60	25713	Vis H,M 6- 16-8.8-ZN5/C Tornillo Vite	- Schraube - Screw -	1	1																		
61	58525	Vis H,M 6- 25-8.8-ZN5/C Tornillo Vite	- Schraube - Screw -	1	1																		
62	75498	Réducteur de pression complet Valvulá de inching completa Riduttore di pressione completo	- Komplette inching ventil - Complete inching valve -	1	1																		
63	6224	Vis H,M 8- 40-8.8-ZN8/C Tornillo Vite	- Schraube - Screw -	2	2																		

+

Catalogue : 647000

				Qté-Menge-Cant-Qty-Q.ta										4 AB		185		M															
6				CIRCUIT TRANSMISSION HYDROSTATIQUE HYDROSTATIK GETRIEBKREIS CIRCUITO TRANSMISION HIDROSTATICO HYDROSTATIC TRANSMISSION CIRCUIT CIRCUITO TRASMISSIONE IDROSTATICA										1- MH20-4T BUG. S2-E3 11-		2- MH25-4T BUG. S2-E3 12-		3- MSI 20T S2-E3 13-		4- MSI 20T BUG. S2-E3 14-		5- MSI 25T S2-E3 15-		6- MSI 25T BUG. S2-E3 16-		7- MSI 30T S2-E3 17-		8- MSI 30T BUG. S2-E3 18-		9- MSI 35T S2-E3 19-		10- MSI 35T BUG. S2-E3 20-	
Rep Hinw Fig Item Rif	Numéro Teil-Nr Numero Part-Nr Part-Nr	Désignation Bezeichnung Descripcion Description Descrizione		1	2	3	4	5	6	7	8	9	10	11	12	13	14	15	16	17	18	19	20										
64	202291	Raccord Union Prolongateur Racor Raccordo	- Verschraubung - Connection -	2	2																												
65	217108	Flexible Flexible Flessibile	- Schlauch - Hose -	1	1																												
66	217677	Raccord Union Prolongateur Racor Raccordo	- Verschraubung - Connection -	1	1																												
67	217678	Flexible Flexible Flessibile	- Schlauch - Hose -	1	1																												
68	236484	Raccord Racor Raccordo	- Verschraubung - Connection -	1	1																												
69	203246	Flexible Flexible Flessibile	- Schlauch - Hose -	1	1																												
70	241634	Raccord Racor Raccordo	- Verschraubung - Connection -	1	1																												
71	202289	Raccord Union Racor Raccordo	- Verschraubung - Connection -	1	1																												
72	190877	Joint d'étanchéité Junta de estanqueidad Guarnizione di tenuta	- Dichtungsring - Seal -	X	X																												
73	497920	Raccord Coudé Adapteur Racor Raccordo	- Verschraubung - Connection -	1	1																												





**4 AB 186**

CIRCUIT TRANSMISSION HYDROSTATIQUE  
 HYDROSTATIK GETRIEBKREIS  
 CIRCUITO TRANSMISION HIDROSTATICO  
 HYDROSTATIC TRANSMISSION CIRCUIT  
 CIRCUITO TRASMISONE IDROSTATICO

**MH 20-4 T BUGGIE S2-E3  
 MH 25-4 T BUGGIE S2-E3**

POUR FLEXIBLE ET RACCORD  
 FÜR SCHLAUCH UND VERSCHRAUBUNG  
 PARA FLEXIBLE Y RACOR  
 FOR HOSE AND CONNECTION  
 PER FLESSIBILE E RACCORDO

POUR TUBE - FÜR ROHR  
 PARA TUBO - FOR TUBE  
 PER TUBO

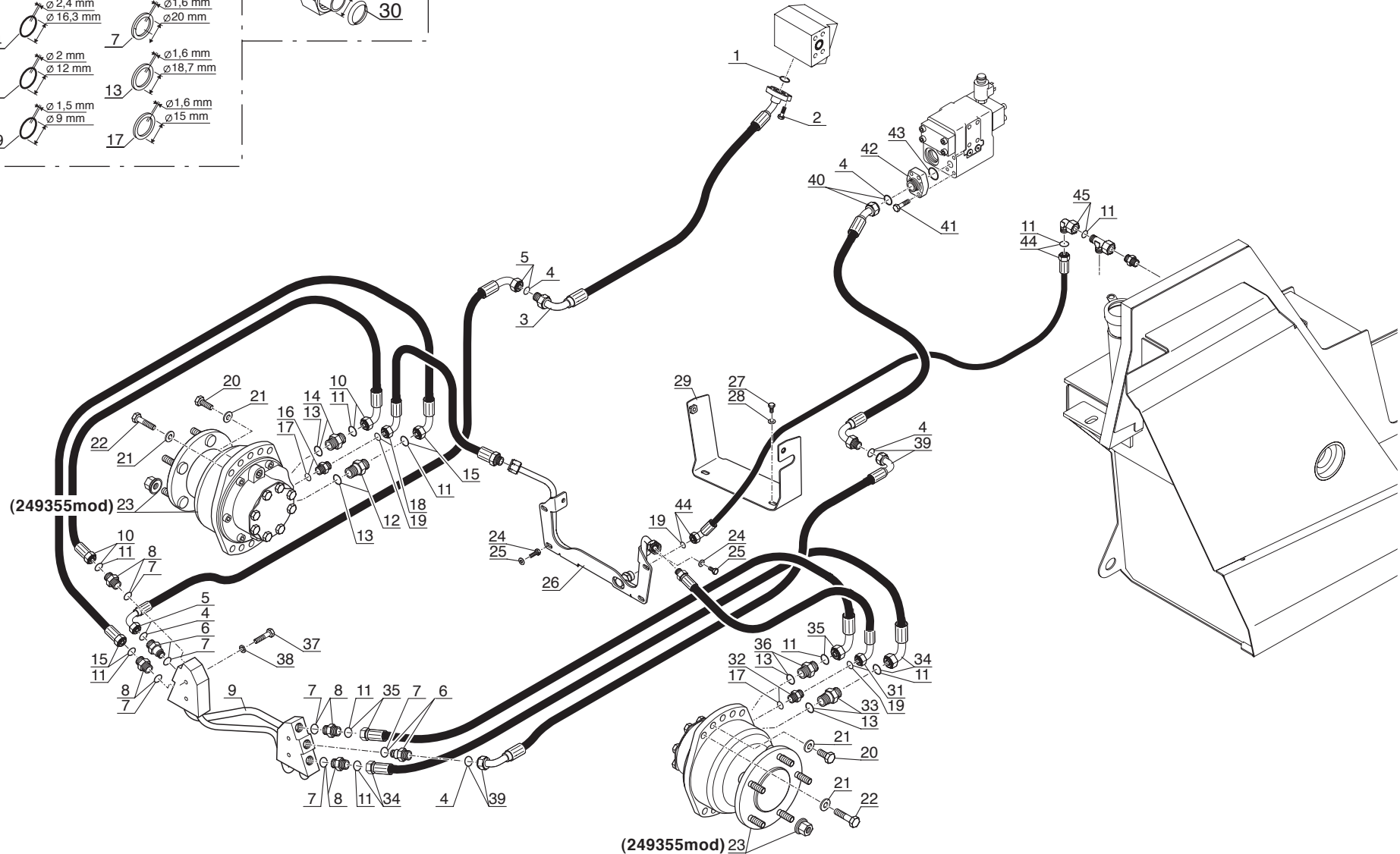
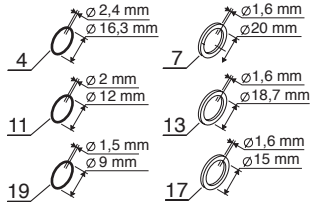

Catalogue : 647000

1				Qté-Menge-Cant-Qty-Q.ta										4 AB		186		M					
CIRCUIT TRANSMISSION HYDROSTATIQUE HYDROSTATIK GETRIEBKREIS CIRCUITO TRANSMISION HIDROSTATICO HYDROSTATIC TRANSMISSION CIRCUIT CIRCUITO TRASMISSIONE IDROSTATICA																							
Rep Hinw Fig Item Rif	Numéro Teil-Nr Numero Part-Nr Part-Nr	Désignation Bezeichnung Descripcion Description Descrizione		1	2	3	4	5	6	7	8	9	10	11	12	13	14	15	16	17	18	19	20
1	85822	Joint torique Junta tórica Anello OR	- "0" ring - "0" ring -	1	1																		
2	210001	Vis H,M10- 35-10.9-ZN8/C Tornillo Vite	- Schraube - Screw -	4	4																		
3	247797	Flexible (Lg 805) Flexible Flessibile	- Schlauch - Hose -	1	1																		
4	86788	Joint torique Junta tórica Anello OR	- "0" ring - "0" ring -	X	X																		
5	250789	Flexible Flexible Flessibile	- Schlauch - Hose -	1	1																		
6	250790	Raccord Union Racor Raccordo	- Verschraubung - Connection -	2	2																		
7	177638	Joint d'étanchéité Junta de estanqueidad Guarnizione	- Dichtungsring - Seal -	X	X																		
8	485396	Raccord Union Racor Raccordo	- Verschraubung - Connection -	4	4																		
9	240709	Bloc d'alimentation Bloque de alimentación Blocco alimentazione	- Zuschieblock - Feed block -	1	1																		
10	257747	Flexible Flexible Flessibile	- Schlauch - Hose -	1	1																		
11	189956	Joint torique Junta tórica Anello OR	- "0" ring - "0" ring -	X	X																		

+

Catalogue : 647000

2

CIRCUIT TRANSMISSION HYDROSTATIQUE  
 HYDROSTATIK GETRIEBKREIS  
 CIRCUITO TRANSMISION HIDROSTATICO  
 HYDROSTATIC TRANSMISSION CIRCUIT  
 CIRCUITO TRASMISSIONE IDROSTATICA

Qté-Menge-Cant-Qty-Q.ta

4 AB

186

M

1-	MH20-4T	BUG. S2-E3	11-
2-	MH25-4T	BUG. S2-E3	12-
3-	MSI 20T	S2-E3	13-
4-	MSI 20T	BUG. S2-E3	14-
5-	MSI 25T	S2-E3	15-
6-	MSI 25T	BUG. S2-E3	16-
7-	MSI 30T	S2-E3	17-
8-	MSI 30T	BUG. S2-E3	18-
9-	MSI 35T	S2-E3	19-
10-	MSI 35T	BUG. S2-E3	20-

Rep Hinw Fig Item Rif	Numéro Teil-Nr Numero Part-Nr Part-Nr	Désignation Bezeichnung Descripcion Description Descrizione	1	2	3	4	5	6	7	8	9	10	11	12	13	14	15	16	17	18	19	20	
12	236949	Raccord Union Prolongateur Racor Raccordo - Verschraubung - Connection -	1	1																			
13	184787	Joint d'étanchéité Junta de estanqueidad Guarnizióne di tenuta - Dichtungsring - Seal -	X	X																			
14	480158	Raccord Union Racor Raccordo - Verschraubung - Connection -	1	1																			
15	257747	Flexible Flexible Flessibile - Schlauch - Hose -	1	1																			
16	192386	Raccord Union Racor Raccordo - Verschraubung - Connection -	1	1																			
17	190877	Joint d'étanchéité Junta de estanqueidad Guarnizióne di tenuta - Dichtungsring - Seal -	X	X																			
18	201118	Flexible Flexible Flessibile - Schlauch - Hose -	1	1																			
19	190874	Joint torique Junta tórica Anello OR - "O" ring - "O" ring -	X	X																			
20	236487	Vis Tornillo Vite - Schraube - Screw -	8	8																			
21	209812	Rondelle HR15 Arandela Rondella - Unterlegscheibe - Washer -	16	16																			
22	487197	Vis H,M14- 40-10.9-ZN8/C Tornillo Vite - Schraube - Screw -	8	8																			

+

Catalogue : 647000

3	CIRCUIT TRANSMISSION HYDROSTATIQUE HYDROSTATIK GETRIEBKREIS CIRCUITO TRANSMISION HIDROSTATICO HYDROSTATIC TRANSMISSION CIRCUIT CIRCUITO TRASMISSIONE IDROSTATICA			Qté-Menge-Cant-Qty-Q.ta										4 AB		186		M					
	Rep Hinw Fig Item Rif	Numéro Teil-Nr Numero Part-Nr Part-Nr	Désignation Bezeichnung Descripcion Description Descrizione	1	2	3	4	5	6	7	8	9	10	11	12	13	14		15	16	17	18	19
23	249355	Moteur de roue Motor de rueda Motorino di ruota	- Rad motor - Wheels motor -	2	2																		
24	54951	Vis H,M 8- 16-8.8-ZN8/C Tornillo Vite	- Schraube - Screw -	6	6																		
25	61674	Rondelle M 8 ZN Arandela Rondella	- Unterlegscheibe - Washer -	6	6																		
26	236488	Tube Tubo Tubo	- Rohr - Tube -	1	1																		
27	54951	Vis H,M 8- 16-8.8-ZN8/C Tornillo Vite	- Schraube - Screw -	2	2																		
28	61674	Rondelle M 8 ZN Arandela Rondella	- Unterlegscheibe - Washer -	2	2																		
29	236970	Support Soporte Supporto	- Träger - Bracket -	1	1																		
30	169437	Joint d'étanchéité Junta de estanqueidad Guarnizióne	- Dichtungsring - Seal -	X	X																		
31	201118	Flexible Flexible Flessibile	- Schlauch - Hose -	1	1																		
32	192386	Raccord Union Racor Raccordo	- Verschraubung - Connection -	1	1																		
33	236949	Raccord Union Prolongateur Racor Raccordo	- Verschraubung - Connection -	1	1																		

+

Catalogue : 647000

Qté-Menge-Cant-Qty-Q.ta

4 AB

186

M

4

CIRCUIT TRANSMISSION HYDROSTATIQUE  
 HYDROSTATIK GETRIEBKREIS  
 CIRCUITO TRANSMISION HIDROSTATICO  
 HYDROSTATIC TRANSMISSION CIRCUIT  
 CIRCUITO TRASMISSIONE IDROSTATICA

1- MH20-4T BUG. S2-E3 11-  
 2- MH25-4T BUG. S2-E3 12-  
 3- MSI 20T S2-E3 13-  
 4- MSI 20T BUG. S2-E3 14-  
 5- MSI 25T S2-E3 15-  
 6- MSI 25T BUG. S2-E3 16-  
 7- MSI 30T S2-E3 17-  
 8- MSI 30T BUG. S2-E3 18-  
 9- MSI 35T S2-E3 19-  
 10- MSI 35T BUG. S2-E3 20-

Rep Hinw Fig Item Rif	Numéro Teil-Nr Numero Part-Nr Part-Nr	Désignation Bezeichnung Descripcion Description Descrizione	1	2	3	4	5	6	7	8	9	10	11	12	13	14	15	16	17	18	19	20
34	257747	Flexible Flexible Flessibile - Schlauch - Hose -	1	1																		
35	257747	Flexible Flexible Flessibile - Schlauch - Hose -	1	1																		
36	480158	Raccord Union Racor Raccordo - Verschraubung - Connection -	1	1																		
37	57446	Vis H,M 8- 25-8.8-ZN8/C Tornillo Vite - Schraube - Screw -	4	4																		
38	42325	Rondelle W 8 ZN Arandela Rondella - Unterlegscheibe - Washer -	4	4																		
39	250788	Flexible Flexible Flessibile - Schlauch - Hose -	1	1																		
40	247798	Flexible (Lg 700) Flexible Flessibile - Schlauch - Hose -	1	1																		
41	210001	Vis H,M10- 35-10.9-ZN8/C Tornillo Vite - Schraube - Screw -	4	4																		
42	236479	Bride Flangia Flangia - Brida - Flange -	1	1																		
43	85822	Joint torique Junta tórica Anello OR - "O" ring - "O" ring -	1	1																		
44	250787	Flexible Flexible Flessibile - Schlauch - Hose -	1	1																		

+

Catalogue : 647000

5

CIRCUIT TRANSMISSION HYDROSTATIQUE  
 HYDROSTATIK GETRIEBKREIS  
 CIRCUITO TRANSMISION HIDROSTATICO  
 HYDROSTATIC TRANSMISSION CIRCUIT  
 CIRCUITO TRASMISSIONE IDROSTATICA

Qté-Menge-Cant-Qty-Q.ta

4 AB

186

M

- 1- MH20-4T BUG. S2-E3 11-
- 2- MH25-4T BUG. S2-E3 12-
- 3- MSI 20T S2-E3 13-
- 4- MSI 20T BUG. S2-E3 14-
- 5- MSI 25T S2-E3 15-
- 6- MSI 25T BUG. S2-E3 16-
- 7- MSI 30T S2-E3 17-
- 8- MSI 30T BUG. S2-E3 18-
- 9- MSI 35T S2-E3 19-
- 10- MSI 35T BUG. S2-E3 20-

Rep Hinw Fig Item Rif	Numéro Teil-Nr Numero Part-Nr Part-Nr	Désignation Bezeichnung Descripcion Description Descrizione
45	202286	Raccord Coudé 90° Adapteur - Verschraubung Racor - Connection Raccordo -

1	2	3	4	5	6	7	8	9	10	11	12	13	14	15	16	17	18	19	20
1	1																		

4 AC 266

CIRCUIT COMBUSTIBLE  
BRENNSTOFFKREIS  
CIRCUITO COMBUSTIBLE  
FUEL CIRCUIT  
SISTEMA NAFTA

MH 20-4 T BUGGIE S2-E3  
MH 25-4 T BUGGIE S2-E3  
MSI 20 / 25 / 30 / 35 T S2-E3  
MSI 20 / 25 / 30 / 35 T BUGGIE S2-E3

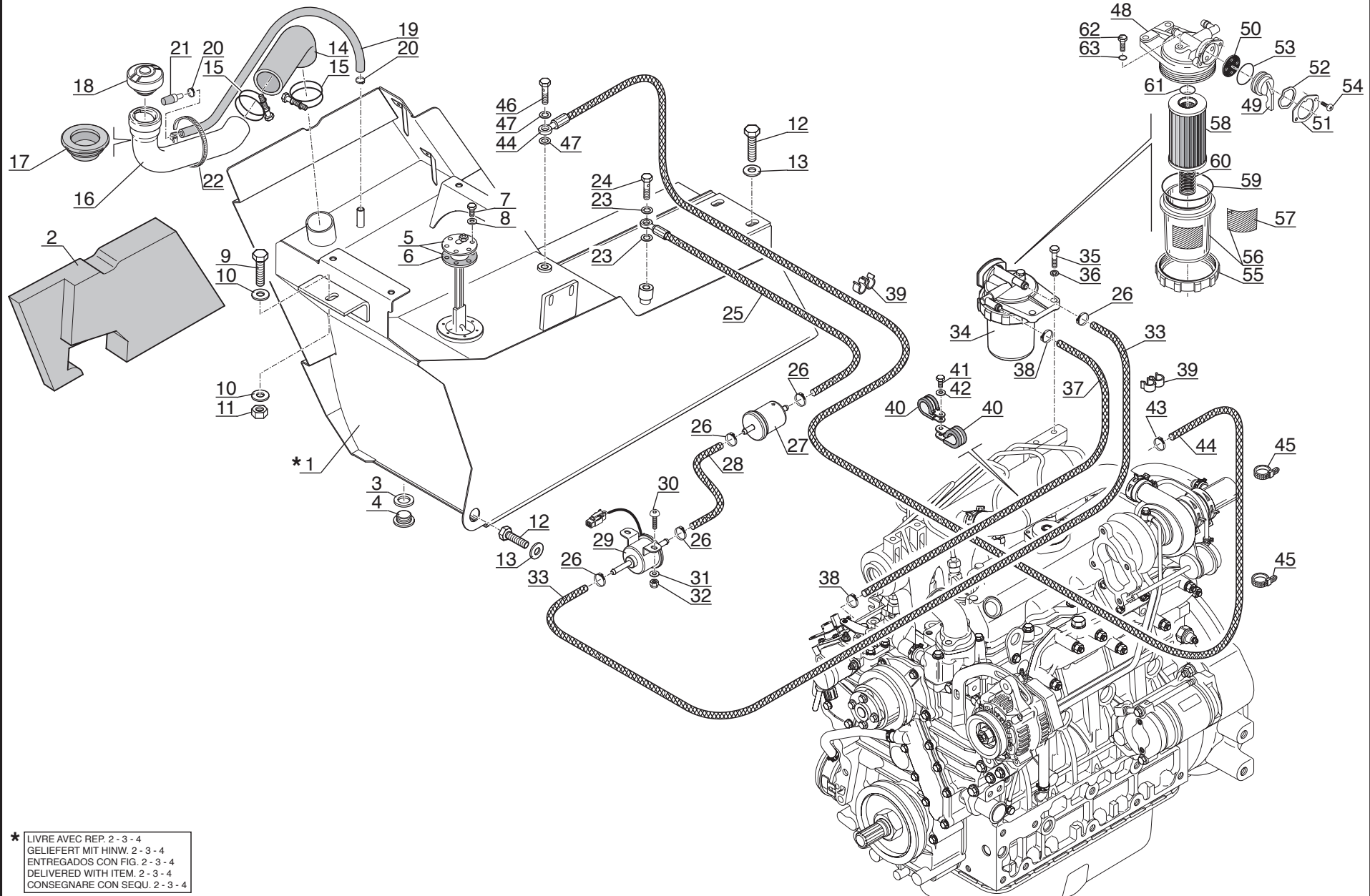

\* LIVRE AVEC REP. 2 - 3 - 4  
GELIEFERT MIT HINW. 2 - 3 - 4  
ENTREGADOS CON FIG. 2 - 3 - 4  
DELIVERED WITH ITEM. 2 - 3 - 4  
CONSEGNARE CON SEQU. 2 - 3 - 4



Catalogue : 647000

1	CIRCUIT COMBUSTIBLE BRENNSTOFFKREIS CIRCUITO COMBUSTIBILE FUEL CIRCUIT CIRCUITO COMBUSTIBILE			Qté-Menge-Cant-Qty-Q.ta										4 AC		266		M					
	Rep Hinw Fig Item Rif	Numéro Teil-Nr Numero Part-Nr Part-Nr	Désignation Bezeichnung Descripcion Description Descrizione	1	2	3	4	5	6	7	8	9	10	11	12	13	14		15	16	17	18	19
1	265221	Réservoir à combustible Tanque de combustible Serbatoio combustibile	- Brennstoffbehälter - Fuel tank -	1	1	1	1	1	1	1	1	1	1										
2	249124	Insonorisant Insonorizador Ammortizzatore	- Schalldämpfungmoos - Sound proofing foam -	1	1	1	1	1	1	1	1	1	1										
3	189536	Joint d'étanchéité Junta de estanqueidad Guarnizióne	- Dichtungsring - Seal -	1	1	1	1	1	1	1	1	1	1										
4	189535	Bouchon Tapón Tappo	- Stopfen - Plug -	1	1	1	1	1	1	1	1	1	1										
5	216357	Jauge à carburant Galga de cargurante Livello carburante	- Kraftstoffmesser - Fuel gauge -	1	1	1	1	1	1	1	1	1	1										
6	187485	Joint plat Junta plana Guarnizióne	- Dichtung - Gasket -	1	1	1	1	1	1	1	1	1	1										
7	167981	Vis H,M 4- 10-8.8-ZN5/C Tornillo Vite	- Schraube - Screw -	6	6	6	6	6	6	6	6	6	6										
8	187294	Joint cuivre Junta cobre Guarnizióne rame	- Kupferdichtung - Copper seal -	6	6	6	6	6	6	6	6	6	6										
9	63547	Vis H,M12- 30-8.8-ZN8/C Tornillo Vite	- Schraube - Screw -	1	1	1	1	1	1	1	1	1	1										
10	44026	Rondelle SP 13 x 45 x 4 ZN Arandela Rondella	- Unterlegscheibe - Washer -	2	2	2	2	2	2	2	2	2	2										
11	58548	Ecrou H ,M12 C 8 ZN..C Tuerca Dado	- Mutter - Nut -	1	1	1	1	1	1	1	1	1	1										

Catalogue : 647000

2

CIRCUIT COMBUSTIBLE  
 BRENNSTOFFKREIS  
 CIRCUITO COMBUSTIBILE  
 FUEL CIRCUIT  
 CIRCUITO COMBUSTIBILE

Qté-Menge-Cant-Qty-Q.ta

4 AC

266

M

- 1- MH20-4T BUG. S2-E3 11-
- 2- MH25-4T BUG. S2-E3 12-
- 3- MSI 20T S2-E3 13-
- 4- MSI 20T BUG. S2-E3 14-
- 5- MSI 25T S2-E3 15-
- 6- MSI 25T BUG. S2-E3 16-
- 7- MSI 30T S2-E3 17-
- 8- MSI 30T BUG. S2-E3 18-
- 9- MSI 35T S2-E3 19-
- 10- MSI 35T BUG. S2-E3 20-

Rep Hinw Fig Item Rif	Numéro Teil-Nr Numero Part-Nr Part-Nr	Désignation Bezeichnung Descripcion Description Descrizione																				
			1	2	3	4	5	6	7	8	9	10	11	12	13	14	15	16	17	18	19	20
12	63547	Vis H,M12- 30-8.8-ZN8/C Tornillo Vite	- Schraube - Screw -	3	3	3	3	3	3	3	3	3	3									
13	44026	Rondelle SP 13 x 45 x 4 ZN Arandela Rondella	- Unterlegscheibe - Washer -	3	3	3	3	3	3	3	3	3	3									
14	222329	Durit Tubo flexible Manicotto	- Schlauch - Hose -	1	1	1	1	1	1	1	1	1	1									
15	9043	Collier Abrazadera Fascetta	- Spannschelle - Clamp -	2	2	2	2	2	2	2	2	2	2									
16	222331	Tube de remplissage Tubo de llenado Tubo di riempimento	- Rohr - Tube -	1	1	1	1	1	1	1	1	1	1									
17	215153	Collerette Collarín Gorgiera	- Bördelflansch - Colector de admision -	1	1	1	1	1	1	1	1	1	1									
18	225200	Bouchon de remplissage Tapón de llenado Tappo di riempimento	- Einfüllverschluss - Filling plug -	1	1	1	1	1	1	1	1	1	1									
19	178382	Durit Tubo flexible Manicotto	- Schlauch - Hose -	1	1	1	1	1	1	1	1	1	1									
20	31468	Collier Abrazadera Fascetta	- Spannschelle - Clamp -	2	2	2	2	2	2	2	2	2	2									
21	222381	Reniflard Respiradero Sfiato	- Entlüftung - Air breather -	1	1	1	1	1	1	1	1	1	1									
22	21980	Collier Abrazadera Fascetta	- Spannschelle - Clamp -	1	1	1	1	1	1	1	1	1	1									

+

Catalogue : 647000

3	CIRCUIT COMBUSTIBLE BRENNSTOFFKREIS CIRCUITO COMBUSTIBILE FUEL CIRCUIT CIRCUITO COMBUSTIBILE			Qté-Menge-Cant-Qty-Q.ta										4 AC		266		M					
	Rep Hinw Fig Item Rif	Numéro Teil-Nr Numero Part-Nr Part-Nr	Désignation Bezeichnung Descripcion Description Descrizione	1	2	3	4	5	6	7	8	9	10	11	12	13	14		15	16	17	18	19
23	3411	Joint cuivre Junta cobre Guarnizione rame	- Kupferdichtung - Copper seal -	2	2	2	2	2	2	2	2	2	2										
24	129397	Vis creuse Tornillo hueco Vite cava	- Hohl schraube - Hollow screw -	1	1	1	1	1	1	1	1	1	1										
25	207096	Flexible (Lg 300) Flexible Flessibile	- Schlauch - Hose -	1	1	1	1	1	1	1	1	1	1										
26	272321	Collier Abrazadera Fascetta	- Spannschelle - Clamp -	5	5	5	5	5	5	5	5	5	5										
27	272194	Préfiltre Prefiltro Prefiltro	- Vorfilter - Pre-filter -	1	1	1	1	1	1	1	1	1	1										
28	274105	Flexible (Lg 300) Flexible Flessibile	- Schlauch - Hose -	1	1	1	1	1	1	1	1	1	1										
29	272195	Pompe d'alimentation Bomba de alimentación Pompa alimentazione	- Brennstoffpumpe - Fuel pump -	1	1	1	1	1	1	1	1	1	1										
30	261495	Vis CBHc,M 6- 12-10.9-ZN5/C FR- Tornillo Vite	- Schraube - Screw -	2	2	2	2	2	2	2	2	2	2										
31	29469	Rondelle M 6 ZN Arandela Rondella	- Unterlegscheibe - Washer -	2	2	2	2	2	2	2	2	2	2										
32	162229	Ecrou H,FR M 6 C 8 ZN..C Tuerca Dado	- Mutter - Nut -	2	2	2	2	2	2	2	2	2	2										
33	274106	Flexible (Lg 650) Flexible Flessibile	- Schlauch - Hose -	1	1	1	1	1	1	1	1	1	1										

+

Catalogue : 647000

4	CIRCUIT COMBUSTIBLE BRENNSTOFFKREIS CIRCUITO COMBUSTIBILE FUEL CIRCUIT CIRCUITO COMBUSTIBILE			Qté-Menge-Cant-Qty-Q.ta										4 AC		266		M					
	Rep Hinw Fig Item Rif	Numéro Teil-Nr Numero Part-Nr Part-Nr	Désignation Bezeichnung Descripcion Description Descrizione	1	2	3	4	5	6	7	8	9	10	11	12	13	14		15	16	17	18	19
34	272193	Filtre à combustible Filtro de combustible Filtro gasolio	- Brennstofffilter - Fuel filter -	1	1	1	1	1	1	1	1	1	1										
35	57446	Vis H,M 8- 25-8.8-ZN8/C Tornillo Vite	- Schraube - Screw -	2	2	2	2	2	2	2	2	2	2										
36	42325	Rondelle W 8 ZN Arandela Rondella	- Unterlegscheibe - Washer -	2	2	2	2	2	2	2	2	2	2										
37	274107	Flexible (Lg 760) Flexible Flessibile	- Schlauch - Hose -	1	1	1	1	1	1	1	1	1	1										
38	272321	Collier Abrazadera Fascetta	- Spannschelle - Clamp -	2	2	2	2	2	2	2	2	2	2										
39	242592	Collier Abrazadera Fascetta	- Spannschelle - Clamp -	3	3	3	3	3	3	3	3	3	3										
40	86504	Collier Abrazadera Fascetta	- Spannschelle - Clamp -	2	2	2	2	2	2	2	2	2	2										
41	4240	Vis H,M 5- 16-8.8-ZN5/C Tornillo Vite	- Schraube - Screw -	1	1	1	1	1	1	1	1	1	1										
42	28959	Rondelle M 5 ZN Arandela Rondella	- Unterlegscheibe - Washer -	1	1	1	1	1	1	1	1	1	1										
43	253534	Collier Abrazadera Fascetta	- Spannschelle - Clamp -	1	1	1	1	1	1	1	1	1	1										
44	274123	Flexible (Lg 1170) Flexible Flessibile	- Schlauch - Hose -	1	1	1	1	1	1	1	1	1	1										

+

Catalogue : 647000

5	CIRCUIT COMBUSTIBLE BRENNSTOFFKREIS CIRCUITO COMBUSTIBILE FUEL CIRCUIT CIRCUITO COMBUSTIBILE			Qté-Menge-Cant-Qty-Q.ta										4 AC		266		M					
	Rep Hinw Fig Item Rif	Número Teil-Nr Numero Part-Nr Part-Nr	Désignation Bezeichnung Descripcion Description Descrizione	1	2	3	4	5	6	7	8	9	10	11	12	13	14		15	16	17	18	19
				1- MH20-4T BUG. S2-E3	11-																		
				2- MH25-4T BUG. S2-E3	12-																		
				3- MSI 20T S2-E3	13-																		
				4- MSI 20T BUG. S2-E3	14-																		
				5- MSI 25T S2-E3	15-																		
				6- MSI 25T BUG. S2-E3	16-																		
				7- MSI 30T S2-E3	17-																		
				8- MSI 30T BUG. S2-E3	18-																		
				9- MSI 35T S2-E3	19-																		
				10- MSI 35T BUG. S2-E3	20-																		
45	164856	Collier Abrazadera Fascetta	- Spannschelle - Clamp -	2	2	2	2	2	2	2	2	2	2										
46	129397	Vis creuse Tornillo hueco Vite cava	- Hohl schraube - Hollow screw -	1	1	1	1	1	1	1	1	1	1										
47	3411	Joint cuivre Junta cobre Guarnizióne rame	- Kupferdichtung - Copper seal -	2	2	2	2	2	2	2	2	2	2										
48	748089	Tête de filtre Cabeza de filtro Testa filtro	- Filter kopf - Filter head -	1	1	1	1	1	1	1	1	1	1										
49	748090	Robinet Grifo Rubinetto	- Hahn - Tap -	1	1	1	1	1	1	1	1	1	1										
50	748091	Joint Junta Guarnizióne	- Dichtung - Seal -	1	1	1	1	1	1	1	1	1	1										
51	748092	Plaque de fixation Placa de fijación Piastra di fissaggio	- Befestigung Platte - Fastening plate -	1	1	1	1	1	1	1	1	1	1										
52	748093	Plaque Placa Piastra	- Platte - Plate -	1	1	1	1	1	1	1	1	1	1										
53	748094	Joint torique Junta tórica Anello OR	- "O" ring - "O" ring -	1	1	1	1	1	1	1	1	1	1										
54	748095	Vis Tornillo Vite	- Schraube - Screw -	2	2	2	2	2	2	2	2	2	2										
55	748096	Ecrou Tuerca Dado	- Mutter - Nut -	1	1	1	1	1	1	1	1	1	1										

Catalogue : 647000

6

CIRCUIT COMBUSTIBLE  
BRENNSTOFFKREIS  
CIRCUITO COMBUSTIBILE  
FUEL CIRCUIT  
CIRCUITO COMBUSTIBILE

Qté-Menge-Cant-Qty-Q.ta

4 AC

266

M

1- MH20-4T BUG. S2-E3 11-  
2- MH25-4T BUG. S2-E3 12-  
3- MSI 20T S2-E3 13-  
4- MSI 20T BUG. S2-E3 14-  
5- MSI 25T S2-E3 15-  
6- MSI 25T BUG. S2-E3 16-  
7- MSI 30T S2-E3 17-  
8- MSI 30T BUG. S2-E3 18-  
9- MSI 35T S2-E3 19-  
10- MSI 35T BUG. S2-E3 20-

Rep Hinw Fig Item Rif	Numéro Teil-Nr Numero Part-Nr Part-Nr	Désignation Bezeichnung Descripcion Description Descrizione	Qté-Menge-Cant-Qty-Q.ta																			
			1	2	3	4	5	6	7	8	9	10	11	12	13	14	15	16	17	18	19	20
56	748097	Cuve Tina Vasca - Bottich - Tank -	1	1	1	1	1	1	1	1	1	1	1									
57	600090	Adhésif Adhesivo Adesivo - Klebstoff - Adhesive -	1	1	1	1	1	1	1	1	1	1	1									
58	748087	Filtre à combustible Filtro de combustible Filtro gasolio - Brennstofffilter - Fuel filter -	1	1	1	1	1	1	1	1	1	1	1									
59	748099	Joint torique Junta tórica Anello OR - "0" ring - "0" ring -	1	1	1	1	1	1	1	1	1	1	1									
60	748100	Ressort Muelle Molla - Feder - Spring -	1	1	1	1	1	1	1	1	1	1	1									
61	748101	Joint torique Junta tórica Anello OR - "0" ring - "0" ring -	1	1	1	1	1	1	1	1	1	1	1									
62	748102	Vis Tornillo Vite - Schraube - Screw -	1	1	1	1	1	1	1	1	1	1	1									
63	823948	Joint torique Junta tórica Anello OR - "0" ring - "0" ring -	1	1	1	1	1	1	1	1	1	1	1									



6 AA 421

CHASSIS - CONTREPOIDS  
 GESTELL - GEGENGEWICHT  
 BASTIDOR - CONTRAPESO  
 FRAME - COUNTERWEIGHT  
 TELAIO - CONTRAPPESO

MH 20-4 T BUGGIE S2-E3  
 MH 25-4 T BUGGIE S2-E3  
 MSI 20 / 25 / 30 / 35 T S2-E3  
 MSI 20 / 25 / 30 / 35 T BUGGIE S2-E3

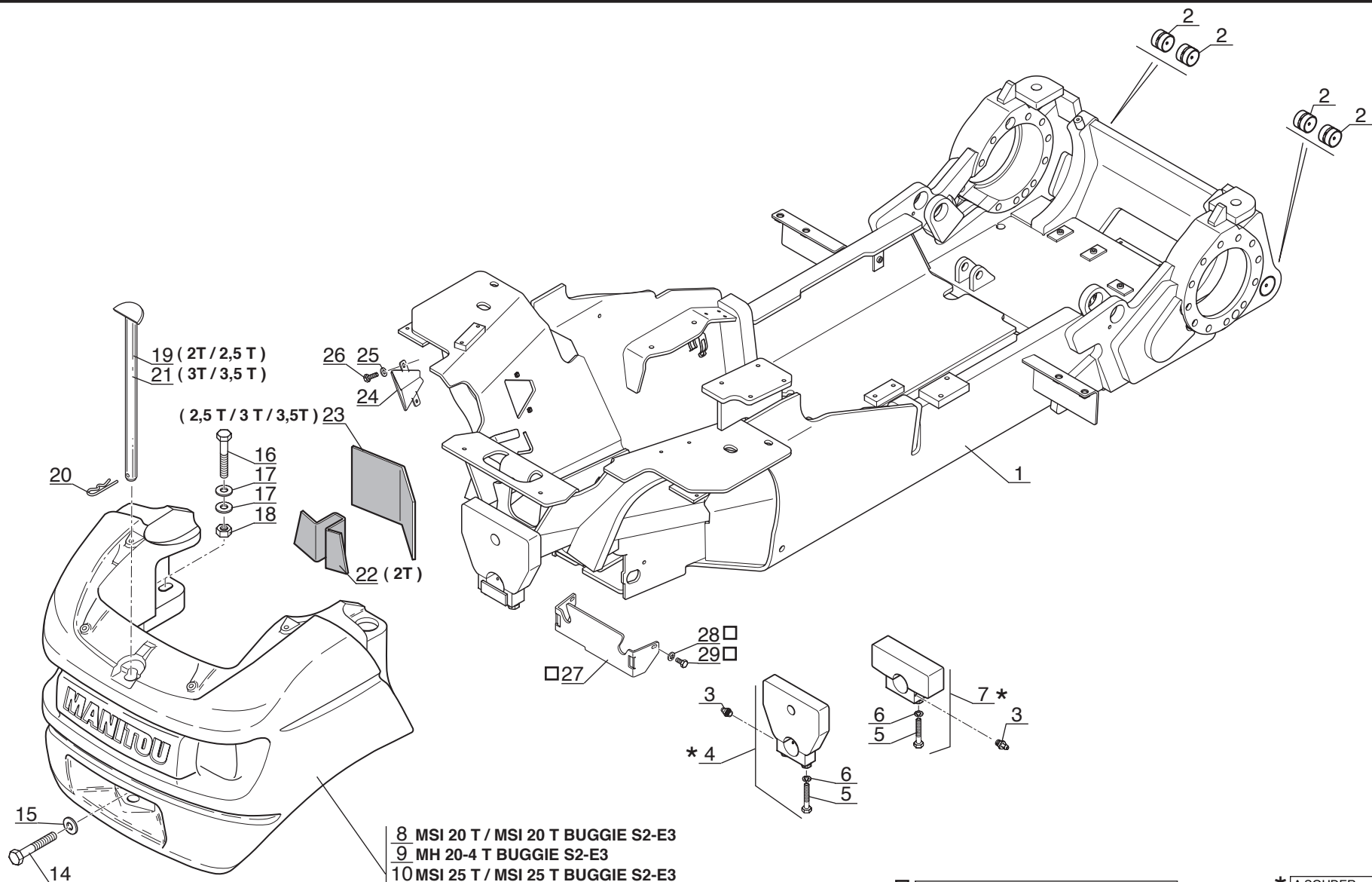

- 8 MSI 20 T / MSI 20 T BUGGIE S2-E3
- 9 MH 20-4 T BUGGIE S2-E3
- 10 MSI 25 T / MSI 25 T BUGGIE S2-E3
- 11 MH 25-4 T BUGGIE S2-E3
- 12 MSI 30 T / MSI 30 T BUGGIE S2-E3
- 13 MSI 35 T / MSI 35 T BUGGIE S2-E3

SEULEMENT POUR - NUR FÜR  
 SOLAMENTE PARA - ONLY FOR - SOLO PER  
 MSI 20 / 25 / 30 / 35 T S2-E3  
 MSI 20 / 25 / 30 / 35 T BUGGIE S2-E3

\* A SOUDER  
 ZU SCHWEISSEN  
 A SOLDAR  
 TO WELD  
 A SALDARE



Catalogue : 647000

Qté-Menge-Cant-Qty-Q.ta

6 AA

421

M

1

CHASSIS - CONTREPOIDS  
 GESTELL - GEGENGEWICHT  
 BASTIDOR - CONTRAPESO  
 FRAME - COUNTERWEIGHT  
 TELAIO - CONTRAPPESO

1- MH20-4T BUG. S2-E3 11-  
 2- MH25-4T BUG. S2-E3 12-  
 3- MSI 20T S2-E3 13-  
 4- MSI 20T BUG. S2-E3 14-  
 5- MSI 25T S2-E3 15-  
 6- MSI 25T BUG. S2-E3 16-  
 7- MSI 30T S2-E3 17-  
 8- MSI 30T BUG. S2-E3 18-  
 9- MSI 35T S2-E3 19-  
 10- MSI 35T BUG. S2-E3 20-

Rep Hinw Fig Item Rif	Numéro Teil-Nr Numero Part-Nr Part-Nr	Désignation Bezeichnung Description Descrizione	1	2	3	4	5	6	7	8	9	10	11	12	13	14	15	16	17	18	19	20
1	268858	Châssis - Gestell Bastidor - Frame Telaio -	1	1	1	1	1	1	1	1	1	1										
2	77408	Bague - Büchse Anillo - Bushing Anello -	4	4	4	4	4	4	4	4	4	4										
3	269	Graisseur - Schmiernippel Engrasador - Greaser Ingrassatore -	2	2	2	2	2	2	2	2	2	2										
4	212708	Palier arrière - Hinter lager Cojinete trasero - Rear bearing Cuscinetti posteriore -	1	1	1	1	1	1	1	1	1	1										
5	163729	Vis H,M16-150- 70-8.8-ZN8/C - Schraube Tornillo - Screw Vite -	4	4	4	4	4	4	4	4	4	4										
6	42322	Rondelle W16 ZN - Unterlegscheibe Arandela - Washer Rondella -	4	4	4	4	4	4	4	4	4	4										
7	268863	Palier avant - Vorn lager Cojinete delantero - Front bearing Cuscinetti anteriore -	1	1	1	1	1	1	1	1	1	1										
8	275319	Contrepoids - Gegengewicht Contrapeso - Counterweight Contrappeso -			1	1																
9	275324	Contrepoids - Gegengewicht Contrapeso - Counterweight Contrappeso -	1																			
10	275320	Contrepoids - Gegengewicht Contrapeso - Counterweight Contrappeso -					1	1														
11	275325	Contrepoids - Gegengewicht Contrapeso - Counterweight Contrappeso -		1																		

+

Catalogue : 647000

2

CHASSIS - CONTREPOIDS  
 GESTELL - GEGENGEWICHT  
 BASTIDOR - CONTRAPESO  
 FRAME - COUNTERWEIGHT  
 TELAIO - CONTRAPPESO

Qté-Menge-Cant-Qty-Q.ta

6 AA

421

M

1-	MH20-4T	BUG. S2-E3	11-
2-	MH25-4T	BUG. S2-E3	12-
3-	MSI 20T	S2-E3	13-
4-	MSI 20T	BUG. S2-E3	14-
5-	MSI 25T	S2-E3	15-
6-	MSI 25T	BUG. S2-E3	16-
7-	MSI 30T	S2-E3	17-
8-	MSI 30T	BUG. S2-E3	18-
9-	MSI 35T	S2-E3	19-
10-	MSI 35T	BUG. S2-E3	20-

Rep Hinw Fig Item Rif	Numéro Teil-Nr Numero Part-Nr Part-Nr	Désignation Bezeichnung Description Descrizione	1	2	3	4	5	6	7	8	9	10	11	12	13	14	15	16	17	18	19	20
12	275327	Contrepoids - Gegengewicht Contrapeso - Counterweight Contrappeso -							1	1												
13	275323	Contrepoids - Gegengewicht Contrapeso - Counterweight Contrappeso -									1	1										
14	172912	Vis H,M30-130-8.8-ZN12/C - Schraube Tornillo - Screw Vite -	1	1	1	1	1	1	1	1	1	1										
15	187218	Rondelle SP 31 x 60 x 8 - Unterlegscheibe Arandela - Washer Rondella -	1	1	1	1	1	1	1	1	1	1										
16	73200	Vis H,M20-160-8.8-ZN8/C - Schraube Tornillo - Screw Vite -	2	2	2	2	2	2	2	2	2	2										
17	204999	Rondelle SP 21 x 50 x10 ZN - Unterlegscheibe Arandela - Washer Rondella -	4	4	4	4	4	4	4	4	4	4										
18	185054	Ecrou H,FR M20 zingué - Mutter Tuerca - Nut Dado -	2	2	2	2	2	2	2	2	2	2										
19	239307	Broche de remorquage - Schleppspindel Brocha de remolque - Towing spindle Broccia di traino -	1	1	1	1	1	1														
20	169076	Goupille "Béta" de 5 - Stift Pasador - Pin Spina -	1	1	1	1	1	1	1	1	1	1										
21	239445	Broche de remorquage - Schleppspindel Brocha de remolque - Towing spindle Broccia di traino -							1	1	1	1										
22	251496	Insonorisant - Schalldämpfungmoos Insonorizador - Sound proofing foam Ammortizzatore -	1		1	1																

+

Catalogue : 647000

3

CHASSIS - CONTREPOIDS  
 GESTELL - GEGENGEWICHT  
 BASTIDOR - CONTRAPESO  
 FRAME - COUNTERWEIGHT  
 TELAIO - CONTRAPPESO

Qté-Menge-Cant-Qty-Q.ta

6 AA

421

M

1-	MH20-4T	BUG. S2-E3	11-
2-	MH25-4T	BUG. S2-E3	12-
3-	MSI 20T	S2-E3	13-
4-	MSI 20T	BUG. S2-E3	14-
5-	MSI 25T	S2-E3	15-
6-	MSI 25T	BUG. S2-E3	16-
7-	MSI 30T	S2-E3	17-
8-	MSI 30T	BUG. S2-E3	18-
9-	MSI 35T	S2-E3	19-
10-	MSI 35T	BUG. S2-E3	20-

Rep Hinw Fig Item Rif	Numéro Teil-Nr Numero Part-Nr Part-Nr	Désignation Bezeichnung Description Descrizione	1	2	3	4	5	6	7	8	9	10	11	12	13	14	15	16	17	18	19	20
23	251497	Insonorisant Insonorizador Ammortizzatore - Schalldämpfungmoos - Sound proofing foam -		1			1	1	1	1	1											
24	275815	Plaque de fermeture Placa de cierre Piastra di chiusura - Schlussplatte - Fastening plate -	1	1	1	1	1	1	1	1	1											
25	29469	Rondelle M 6 ZN Arandela Rondella - Unterlegscheibe - Washer -	2	2	2	2	2	2	2	2	2											
26	46668	Vis H,M 6- 20-8.8-ZN5/C Tornillo Vite - Schraube - Screw -	2	2	2	2	2	2	2	2	2											
27	239962	Plaque de fermeture Placa de cierre Piastra di chiusura - Schlussplatte - Fastening plate -			1	1	1	1	1	1	1											
28	174132	Rondelle JZC 6 CAD.BICH Arandela Rondella - Unterlegscheibe - Washer -			2	2	2	2	2	2	2											
29	46668	Vis H,M 6- 20-8.8-ZN5/C Tornillo Vite - Schraube - Screw -			2	2	2	2	2	2	2											

6 BB 188

PEDALERIE - TRINGLERIE  
PEDALEN- GESTANGE  
PEDALES - VARILLAS  
PEDALS - LINKAGE  
PEDALI - COMANDI

MH 20-4 T BUGGIE S2-E3  
MH 25-4 T BUGGIE S2-E3  
MSI 20 / 25 / 30 / 35 T S2-E3  
MSI 20 / 25 / 30 / 35 T BUGGIE S2-E3

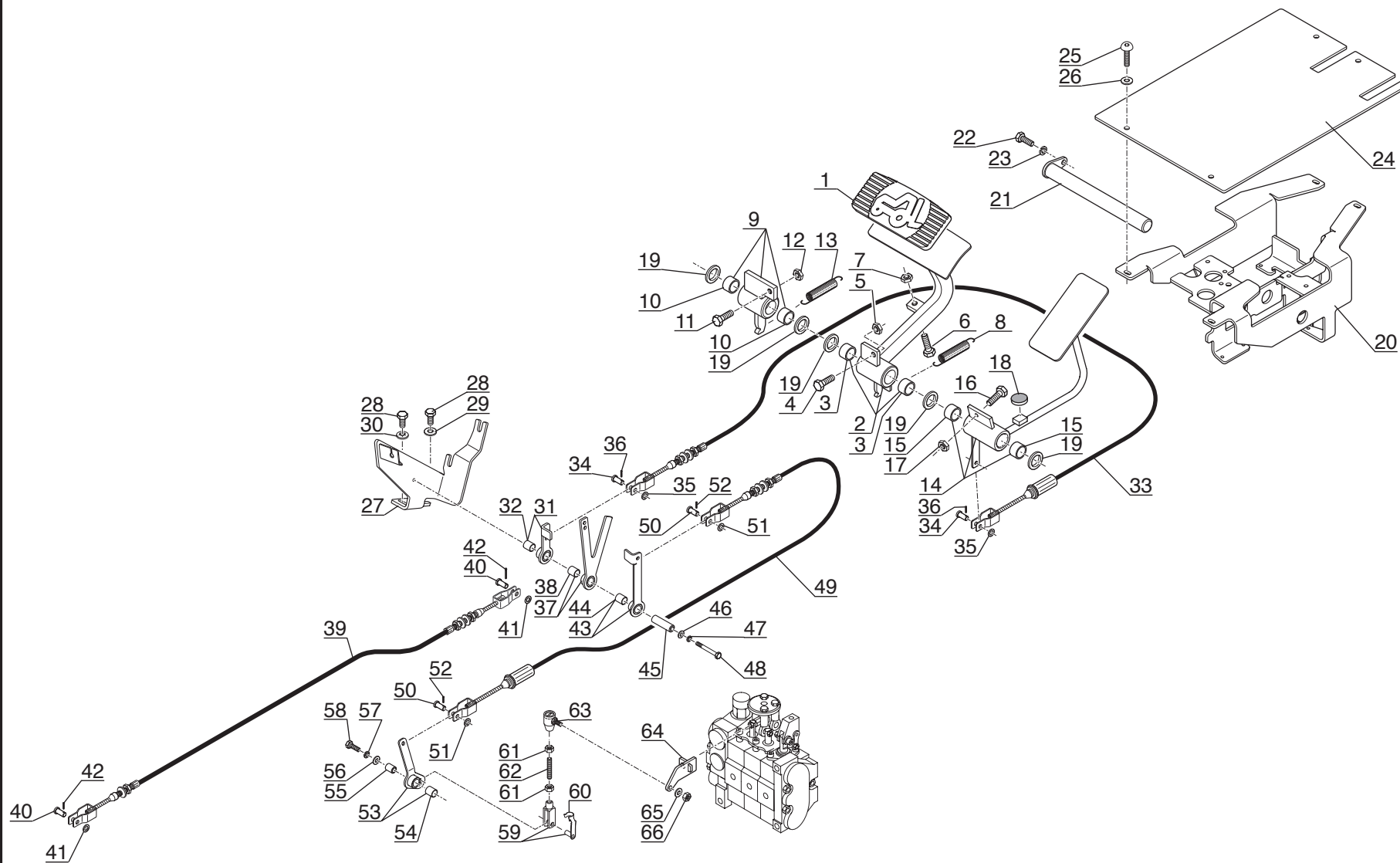

Catalogue : 647000

1	PEDALERIE - TRINGLERIE PEDALEN - GESTANGE PEDALES - VARILLAS PEDALS - LINKAGE PEDALI - COMANDI			Qté-Menge-Cant-Qty-Q.ta							6 BB		188		M								
	Rep Hinw Fig Item Rif	Numéro Teil-Nr Numero Part-Nr Part-Nr	Désignation Bezeichnung Descripcion Description Descrizione	1	2	3	4	5	6	7	8	9	10	11		12	13	14	15	16	17	18	19
1	240821	Couvre pédale Cubre pedal Gomma pedale	- Deck pedal - Cover pedal -	1	1	1	1	1	1	1	1	1	1										
2	217674	Pédale de frein Pedal de freno Pedale pompa freno	- Bremsepedal - Brake pedal -	1	1	1	1	1	1	1	1	1	1										
3	172569	Bague Anillo Anello	- Büchse - Bushing -	2	2	2	2	2	2	2	2	2	2										
4	57446	Vis H,M 8- 25-8.8-ZN8/C Tornillo Vite	- Schraube - Screw -	1	1	1	1	1	1	1	1	1	1										
5	3212	Ecrou Hm, M 8 C05 ZN.C Tuerca Dado	- Mutter - Nut -	1	1	1	1	1	1	1	1	1	1										
6	61323	Vis H,M 8- 35-8.8-ZN8/C Tornillo Vite	- Schraube - Screw -	1	1	1	1	1	1	1	1	1	1										
7	3212	Ecrou Hm, M 8 C05 ZN.C Tuerca Dado	- Mutter - Nut -	1	1	1	1	1	1	1	1	1	1										
8	5398	Ressort Muelle Molla	- Feder - Spring -	1	1	1	1	1	1	1	1	1	1										
9	217675	Moyeu de renvoi Cubo de cambio Mozzo di rinvio	- Vorgele nabe - Counter hub -	1	1	1	1	1	1	1	1	1	1										
10	172569	Bague Anillo Anello	- Büchse - Bushing -	2	2	2	2	2	2	2	2	2	2										
11	63754	Vis H,M 8- 30-8.8-ZN8/C Tornillo Vite	- Schraube - Screw -	1	1	1	1	1	1	1	1	1	1										

+

Catalogue : 647000

2

PEDALERIE - TRINGLERIE  
 PEDALEN - GESTANGE  
 PEDALES - VARILLAS  
 PEDALS - LINKAGE  
 PEDALI - COMANDI

Qté-Menge-Cant-Qty-Q.ta

6 BB

188

M

1-	MH20-4T	BUG. S2-E3	11-
2-	MH25-4T	BUG. S2-E3	12-
3-	MSI 20T	S2-E3	13-
4-	MSI 20T	BUG. S2-E3	14-
5-	MSI 25T	S2-E3	15-
6-	MSI 25T	BUG. S2-E3	16-
7-	MSI 30T	S2-E3	17-
8-	MSI 30T	BUG. S2-E3	18-
9-	MSI 35T	S2-E3	19-
10-	MSI 35T	BUG. S2-E3	20-

Rep Hinw Fig Item Rif	Numéro Teil-Nr Numero Part-Nr Part-Nr	Désignation Bezeichnung Descripcion Description Descrizione	1	2	3	4	5	6	7	8	9	10	11	12	13	14	15	16	17	18	19	20
12	3212	Ecrou Hm, M 8 C05 ZN.C Tuerca Dado - Mutter - Nut -	1	1	1	1	1	1	1	1	1	1										
13	5398	Ressort Muelle Molla - Feder - Spring -	1	1	1	1	1	1	1	1	1	1										
14	270888	Pédale d'accélérateur Pedal de acelerador Pedale acceleratore - Gaspedal - Accelerator pedal -	1	1	1	1	1	1	1	1	1	1										
15	172569	Bague Anillo Anello - Büchse - Bushing -	2	2	2	2	2	2	2	2	2	2										
16	57446	Vis H,M 8- 25-8.8-ZN8/C Tornillo Vite - Schraube - Screw -	1	1	1	1	1	1	1	1	1	1										
17	3212	Ecrou Hm, M 8 C05 ZN.C Tuerca Dado - Mutter - Nut -	1	1	1	1	1	1	1	1	1	1										
18	184130	Butée Tope Battuta - Anschlag - Stop -	1	1	1	1	1	1	1	1	1	1										
19	432161011071	Rondelle SP 28,5x 50 x 0,5 Arandela Rondella - Unterlegscheibe - Washer -	X	X	X	X	X	X	X	X	X	X										
19	432171011071	Rondelle SP 28,5x 50 x 1 Arandela Rondella - Unterlegscheibe - Washer -	X	X	X	X	X	X	X	X	X	X										
20	215994	Support pédalerie Soporte pedales Supporto pedali - Pedalenträger - Pedals bracket -	1	1	1	1	1	1	1	1	1	1										
21	216022	Axe d'articulation Eje de articulación Perno di articolazione - Gelenkachse - Articulating pin -	1	1	1	1	1	1	1	1	1	1										

+

Catalogue : 647000

3

PEDALERIE - TRINGLERIE  
 PEDALEN - GESTANGE  
 PEDALES - VARILLAS  
 PEDALS - LINKAGE  
 PEDALI - COMANDI

Qté-Menge-Cant-Qty-Q.ta

6 BB

188

M

1-	MH20-4T	BUG. S2-E3	11-
2-	MH25-4T	BUG. S2-E3	12-
3-	MSI 20T	S2-E3	13-
4-	MSI 20T	BUG. S2-E3	14-
5-	MSI 25T	S2-E3	15-
6-	MSI 25T	BUG. S2-E3	16-
7-	MSI 30T	S2-E3	17-
8-	MSI 30T	BUG. S2-E3	18-
9-	MSI 35T	S2-E3	19-
10-	MSI 35T	BUG. S2-E3	20-

Rep Hinw Fig Item Rif	Numéro Teil-Nr Numero Part-Nr Part-Nr	Désignation Bezeichnung Description Descrizione	1	2	3	4	5	6	7	8	9	10	11	12	13	14	15	16	17	18	19	20
22	50896	Vis H,M 6- 10-8.8-ZN5/C Tornillo Vite - Schraube - Screw -	1	1	1	1	1	1	1	1	1	1										
23	42316	Rondelle W 6 ZN Arandela Rondella - Unterlegscheibe - Washer -	1	1	1	1	1	1	1	1	1	1										
24	216020	Plaque de fermeture Placa de cierre Piastra di chiusura - Schlussplatte - Fastening plate -	1	1	1	1	1	1	1	1	1	1										
25	190732	Vis CBHc,M 6- 25-ZN Tornillo Vite - Schraube - Screw -	4	4	4	4	4	4	4	4	4	4										
26	189857	Rondelle M 6 ZN PASS.NOIRE Arandela Rondella - Unterlegscheibe - Washer -	4	4	4	4	4	4	4	4	4	4										
27	274520	Support Soporte Supporto - Halter - Bracket -	1	1	1	1	1	1	1	1	1	1										
28	54951	Vis H,M 8- 16-8.8-ZN8/C Tornillo Vite - Schraube - Screw -	2	2	2	2	2	2	2	2	2	2										
29	29468	Rondelle L 8 ZN12C/FE Arandela Rondella - Unterlegscheibe - Washer -	1	1	1	1	1	1	1	1	1	1										
30	63351	Rondelle JZC 8 CAD.BICH Arandela Rondella - Unterlegscheibe - Washer -	1	1	1	1	1	1	1	1	1	1										
31	210755	Renvoi Cambio Rinvio - Vorgelege - Counter -	1	1	1	1	1	1	1	1	1	1										
32	210776	Bague Anillo Anello - Büchse - Bushing -	1	1	1	1	1	1	1	1	1	1										

+

Catalogue : 647000

4

PEDALERIE - TRINGLERIE  
 PEDALEN - GESTANGE  
 PEDALES - VARILLAS  
 PEDALS - LINKAGE  
 PEDALI - COMANDI

Qté-Menge-Cant-Qty-Q.ta

6 BB

188

M

1-	MH20-4T	BUG. S2-E3	11-
2-	MH25-4T	BUG. S2-E3	12-
3-	MSI 20T	S2-E3	13-
4-	MSI 20T	BUG. S2-E3	14-
5-	MSI 25T	S2-E3	15-
6-	MSI 25T	BUG. S2-E3	16-
7-	MSI 30T	S2-E3	17-
8-	MSI 30T	BUG. S2-E3	18-
9-	MSI 35T	S2-E3	19-
10-	MSI 35T	BUG. S2-E3	20-

Rep Hinw Fig Item Rif	Numéro Teil-Nr Numero Part-Nr Part-Nr	Désignation Bezeichnung Descripcion Description Descrizione	1	2	3	4	5	6	7	8	9	10	11	12	13	14	15	16	17	18	19	20
33	270353	Câble d'accélérateur Cable de acelerador Cavo acceleratore - Gaskabel - Accelerator cable -	1	1	1	1	1	1	1	1	1	1										
34	561251	Axe Eje Perno - Bolzen - Pin -	2	2	2	2	2	2	2	2	2	2										
35	29469	Rondelle M 6 ZN Arandela Rondella - Unterlegscheibe - Washer -	2	2	2	2	2	2	2	2	2	2										
36	35000	Goupille V 2 x 20 zinguée Pasador Spina - Stift - Pin -	2	2	2	2	2	2	2	2	2	2										
37	270519	Renvoi Cambio Rinvio - Vorgelege - Counter -	1	1	1	1	1	1	1	1	1	1										
38	210776	Bague Anillo Anello - Büchse - Bushing -	1	1	1	1	1	1	1	1	1	1										
39	270354	Câble d'accélérateur Cable de acelerador Cavo acceleratore - Gaskabel - Accelerator cable -	1	1	1	1	1	1	1	1	1	1										
40	561251	Axe Eje Perno - Bolzen - Pin -	2	2	2	2	2	2	2	2	2	2										
41	29469	Rondelle M 6 ZN Arandela Rondella - Unterlegscheibe - Washer -	2	2	2	2	2	2	2	2	2	2										
42	1082	Goupille V 2 x 25 ZN12C Pasador Spina - Stift - Pin -	2	2	2	2	2	2	2	2	2	2										
43	270523	Renvoi Cambio Rinvio - Vorgelege - Counter -	1	1	1	1	1	1	1	1	1	1										

+



Catalogue : 647000

5

PEDALERIE - TRINGLERIE  
 PEDALEN - GESTANGE  
 PEDALES - VARILLAS  
 PEDALS - LINKAGE  
 PEDALI - COMANDI

Qté-Menge-Cant-Qty-Q.ta

6 BB

188

M

1-	MH20-4T	BUG. S2-E3	11-
2-	MH25-4T	BUG. S2-E3	12-
3-	MSI 20T	S2-E3	13-
4-	MSI 20T	BUG. S2-E3	14-
5-	MSI 25T	S2-E3	15-
6-	MSI 25T	BUG. S2-E3	16-
7-	MSI 30T	S2-E3	17-
8-	MSI 30T	BUG. S2-E3	18-
9-	MSI 35T	S2-E3	19-
10-	MSI 35T	BUG. S2-E3	20-

Rep Hinw Fig Item Rif	Numéro Teil-Nr Numero Part-Nr Part-Nr	Désignation Bezeichnung Descripcion Description Descrizione	1	2	3	4	5	6	7	8	9	10	11	12	13	14	15	16	17	18	19	20
44	210776	Bague Anillo Anello - BÜchse - Bushing -	1	1	1	1	1	1	1	1	1	1										
45	210781	Axe d'articulation Eje de articulación Perno di articolazione - Gelenkachse - Articulating pin -	1	1	1	1	1	1	1	1	1	1										
46	459749	Rondelle L 6 ZN Arandela Rondella - Unterlegscheibe - Washer -	1	1	1	1	1	1	1	1	1	1										
47	42316	Rondelle W 6 ZN Arandela Rondella - Unterlegscheibe - Washer -	1	1	1	1	1	1	1	1	1	1										
48	60950	Vis H,M 6- 60-8.8-ZN5/C Tornillo Vite - Schraube - Screw -	1	1	1	1	1	1	1	1	1	1										
49	270441	Câble Cable Cavo - Kabel - Cable -	1	1	1	1	1	1	1	1	1	1										
50	561251	Axe Eje Perno - Bolzen - Pin -	2	2	2	2	2	2	2	2	2	2										
51	29469	Rondelle M 6 ZN Arandela Rondella - Unterlegscheibe - Washer -	2	2	2	2	2	2	2	2	2	2										
52	35000	Goupille V 2 x 20 zinguée Pasador Spina - Stift - Pin -	2	2	2	2	2	2	2	2	2	2										
53	216065	Renvoi Cambio Rinvio - Vorgelege - Counter -	1	1	1	1	1	1	1	1	1	1										
54	210776	Bague Anillo Anello - BÜchse - Bushing -	1	1	1	1	1	1	1	1	1	1										

+

Catalogue : 647000

6

PEDALERIE - TRINGLERIE  
 PEDALEN - GESTANGE  
 PEDALES - VARILLAS  
 PEDALS - LINKAGE  
 PEDALI - COMANDI

Qté-Menge-Cant-Qty-Q.ta

6 BB

188

M

1-	MH20-4T	BUG. S2-E3	11-
2-	MH25-4T	BUG. S2-E3	12-
3-	MSI 20T	S2-E3	13-
4-	MSI 20T	BUG. S2-E3	14-
5-	MSI 25T	S2-E3	15-
6-	MSI 25T	BUG. S2-E3	16-
7-	MSI 30T	S2-E3	17-
8-	MSI 30T	BUG. S2-E3	18-
9-	MSI 35T	S2-E3	19-
10-	MSI 35T	BUG. S2-E3	20-

Rep Hinw Fig Item Rif	Numéro Teil-Nr Numero Part-Nr Part-Nr	Désignation Bezeichnung Descripcion Description Descrizione	1	2	3	4	5	6	7	8	9	10	11	12	13	14	15	16	17	18	19	20
55	241671	Bague Anillo Anello - BÜchse - Bushing -	1	1	1	1	1	1	1	1	1	1										
56	29468	Rondelle L 8 ZN12C/FE Arandela Rondella - Unterlegscheibe - Washer -	1	1	1	1	1	1	1	1	1	1										
57	42325	Rondelle W 8 ZN Arandela Rondella - Unterlegscheibe - Washer -	1	1	1	1	1	1	1	1	1	1										
58	57446	Vis H,M 8- 25-8.8-ZN8/C Tornillo Vite - Schraube - Screw -	1	1	1	1	1	1	1	1	1	1										
59	169994	Chape complète Abrazadera completa Forchetta completa - Kompletter gabelgelenk - Complete fork joint -	1	1	1	1	1	1	1	1	1	1										
60	174835	Axe Eje Perno - Bolzen - Pin -	1	1	1	1	1	1	1	1	1	1										
61	25714	Ecrou H ,M 6 ZN Tuerca Dado - Mutter - Nut -	2	2	2	2	2	2	2	2	2	2										
62	234197	Vis AHc,M 6- 50-33H-ZN8/NOIR Tornillo Vite - Schraube - Screw -	1	1	1	1	1	1	1	1	1	1										
63	127165	Rotule Rótula Rotula - Kugelgelenk - Knee-joint -	1	1	1	1	1	1	1	1	1	1										
64	216068	Levier d'accélérateur Palanca de acelerador Leva acceleratore - Gashebel - Accelerator lever -	1	1	1	1	1	1	1	1	1	1										
65	29469	Rondelle M 6 ZN Arandela Rondella - Unterlegscheibe - Washer -	1	1	1	1	1	1	1	1	1	1										

+

Catalogue : 647000

7

PEDALERIE - TRINGLERIE  
 PEDALEN - GESTANGE  
 PEDALES - VARILLAS  
 PEDALS - LINKAGE  
 PEDALI - COMANDI

Qté-Menge-Cant-Qty-Q.ta

6 BB

188

M

1-	MH20-4T	BUG. S2-E3	11-
2-	MH25-4T	BUG. S2-E3	12-
3-	MSI 20T	S2-E3	13-
4-	MSI 20T	BUG. S2-E3	14-
5-	MSI 25T	S2-E3	15-
6-	MSI 25T	BUG. S2-E3	16-
7-	MSI 30T	S2-E3	17-
8-	MSI 30T	BUG. S2-E3	18-
9-	MSI 35T	S2-E3	19-
10-	MSI 35T	BUG. S2-E3	20-

Rep Hinw Fig Item Rif	Numéro Teil-Nr Numero Part-Nr Part-Nr	Désignation Bezeichnung Descripcion Description Descrizione
66	25714	Ecrou H ,M 6 ZN Tuerca Dado - Mutter - Nut -

1	2	3	4	5	6	7	8	9	10	11	12	13	14	15	16	17	18	19	20
1	1	1	1	1	1	1	1	1	1										

7 AA 47

ESSIEU ARRIERE  
HINTERACHSE  
EJE TRASERO  
REAR AXLE  
PONTE POSTERIORE

MH 20-4 T BUGGIE S2-E3  
MH 25-4 T BUGGIE S2-E3

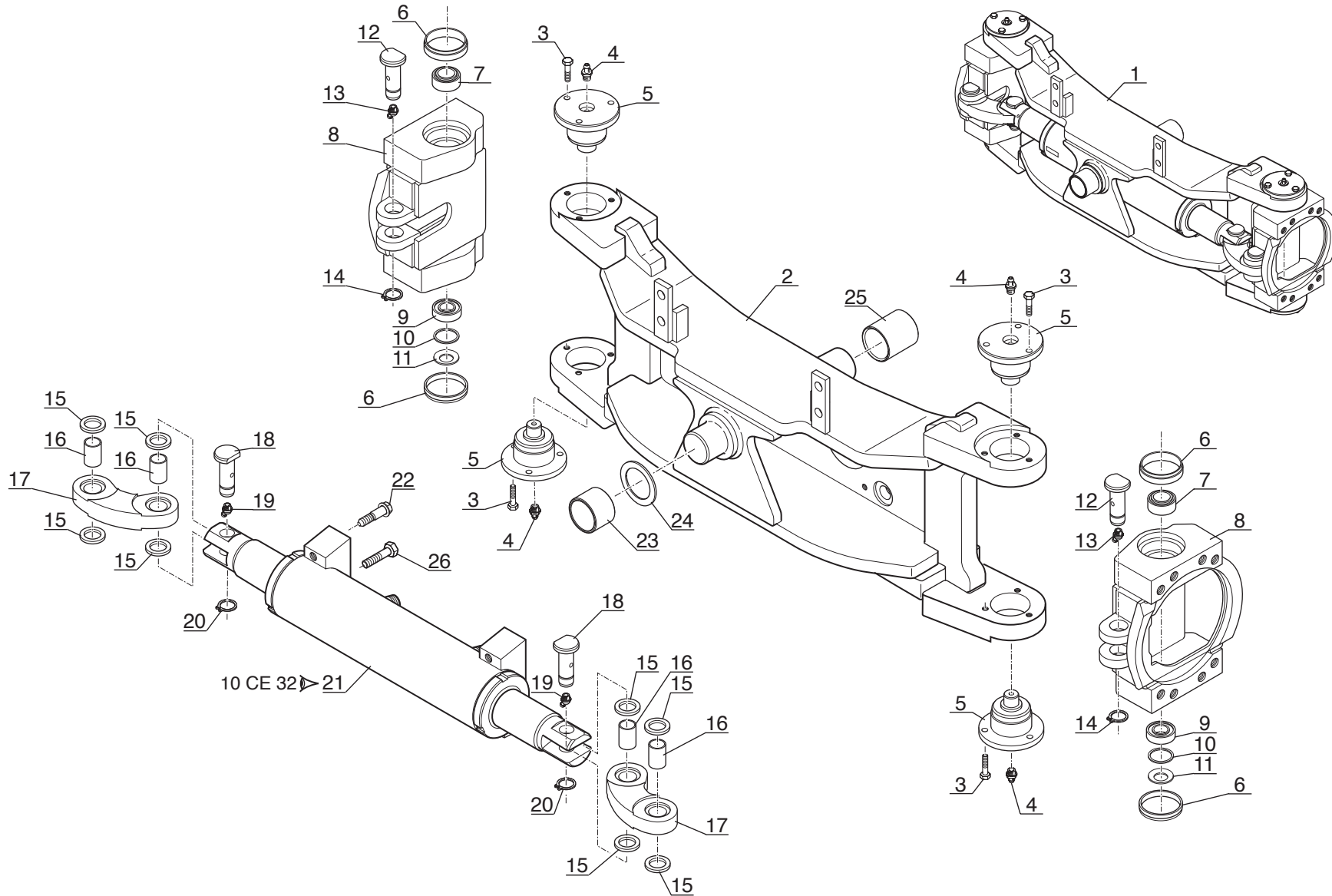

Catalogue : 647000

Qté-Menge-Cant-Qty-Q.ta | 7 AA 47 | M

1	ESSIEU ARRIERE HINTERACHSE EJE TRASERO REAR AXLE PONTE POSTERIORE			1- MH20-4T BUG. S2-E3 11- 2- MH25-4T BUG. S2-E3 12- 3- MSI 20T S2-E3 13- 4- MSI 20T BUG. S2-E3 14- 5- MSI 25T S2-E3 15- 6- MSI 25T BUG. S2-E3 16- 7- MSI 30T S2-E3 17- 8- MSI 30T BUG. S2-E3 18- 9- MSI 35T S2-E3 19- 10- MSI 35T BUG. S2-E3 20-																			
	Rep Hinw Fig Item Rif	Numéro Teil-Nr Numero Part-Nr Part-Nr	Désignation Bezeichnung Descripcion Description Descrizione	1	2	3	4	5	6	7	8	9	10	11	12	13	14	15	16	17	18	19	20
1	249992	Essieu arrière complet Eje trasero completo Assale posteriore completo	- Kompletter Hinterachse - Complete rear axle -	1	1																		
2	249942	Essieu arrière Eje trasero Assale posteriore	- Hinterachse - Rear axle -	1	1																		
3	210001	Vis H,M10- 35-10.9-ZN8/C Tornillo Vite	- Schraube - Screw -	12	12																		
4	5135	Graisser droit (M 10 x 150) Engrasador recto Ingrassatore destro	- Gerade schmiernippel - Straight greaser -	4	4																		
5	239509	Axe de pivot Eje Perno	- Achse - Axle -	4	4																		
6	239270	Joint d'étanchéité Junta de estanqueidad Guarnizione di tenuta	- Dichtungsring - Seal -	4	4																		
7	220498	Roulement Rodamiento Cuscinetto	- Lager - Bearing -	2	2																		
8	239512	Pivot Pivote Perno	- Zapfen - Pin -	2	2																		
9	239519	Roulement Rodamiento Cuscinetto	- Lager - Bearing -	2	2																		
10	239520	Rondelle Arandela Rondella	- Unterlegscheibe - Washer -	2	2																		
11	239518	Rondelle Arandela Rondella	- Unterlegscheibe - Washer -	2	2																		

+

Catalogue : 647000

2

ESSIEU ARRIERE  
HINTERACHSE  
EJE TRASERO  
REAR AXLE  
PONTE POSTERIORE

Qté-Menge-Cant-Qty-Q.ta

7 AA

47

M

1-	MH20-4T	BUG. S2-E3	11-
2-	MH25-4T	BUG. S2-E3	12-
3-	MSI 20T	S2-E3	13-
4-	MSI 20T	BUG. S2-E3	14-
5-	MSI 25T	S2-E3	15-
6-	MSI 25T	BUG. S2-E3	16-
7-	MSI 30T	S2-E3	17-
8-	MSI 30T	BUG. S2-E3	18-
9-	MSI 35T	S2-E3	19-
10-	MSI 35T	BUG. S2-E3	20-

Rep Hinw Fig Item Rif	Numéro Teil-Nr Numero Part-Nr Part-Nr	Désignation Bezeichnung Descripcion Description Descrizione	1	2	3	4	5	6	7	8	9	10	11	12	13	14	15	16	17	18	19	20	
12	239511	Axe Eje Perno - Bolzen - Pin -	2	2																			
13	22254	Graisseur ( 6 x 100C) 45° Engrasador Ingrassatore - Schmiernippel - Greaser -	2	2																			
14	51276	Circlips Aro retén Anello elastico - Sicherungsring - Circlip -	2	2																			
15	239272	Joint d'étanchéité Junta de estanqueidad Guarnizione di tenuta - Dichtungsring - Seal -	8	8																			
16	239271	Bague Anillo Anello - Büchse - Bushing -	4	4																			
17	239510	Biellette Biela Biella - Stange - Rod -	2	2																			
18	239511	Axe Eje Perno - Bolzen - Pin -	2	2																			
19	22254	Graisseur ( 6 x 100C) 45° Engrasador Ingrassatore - Schmiernippel - Greaser -	2	2																			
20	51276	Circlips Aro retén Anello elastico - Sicherungsring - Circlip -	2	2																			
21	236431	Vérin direction D:60mm C:2x65mm Lenkungszylinder Cilindro de dirección Cilindro di sterzo - Steering cylinder -	1	1																			
22	240457	Vis Tornillo Vite - Schraube - Screw -	2	2																			

+

Catalogue : 647000

3

ESSIEU ARRIERE  
HINTERACHSE  
EJE TRASERO  
REAR AXLE  
PONTE POSTERIORE

Qté-Menge-Cant-Qty-Q.ta

7 AA

47

M

1-	MH20-4T	BUG. S2-E3	11-
2-	MH25-4T	BUG. S2-E3	12-
3-	MSI 20T	S2-E3	13-
4-	MSI 20T	BUG. S2-E3	14-
5-	MSI 25T	S2-E3	15-
6-	MSI 25T	BUG. S2-E3	16-
7-	MSI 30T	S2-E3	17-
8-	MSI 30T	BUG. S2-E3	18-
9-	MSI 35T	S2-E3	19-
10-	MSI 35T	BUG. S2-E3	20-

Rep Hinw Fig Item Rif	Numéro Teil-Nr Numero Part-Nr Part-Nr	Désignation Bezeichnung Descripcion Description Descrizione																				
			1	2	3	4	5	6	7	8	9	10	11	12	13	14	15	16	17	18	19	20
23	51313F203071	Bague Anillo Anello - BÜchse - Bushing -	1	1																		
24	209552	Cale d'épaisseur 3 mm Cala de espesor Spessore - Ausgleichscheibe - Shim -	X	X																		
24	209553	Cale d'épaisseur 3,5 mm Cala de espesor Spessore - Ausgleichscheibe - Shim -	X	X																		
24	209554	Cale d'épaisseur 4 mm Cala de espesor Spessore - Ausgleichscheibe - Shim -	X	X																		
24	209555	Cale d'épaisseur 4,5 mm Cala de espesor Spessore - Ausgleichscheibe - Shim -	X	X																		
24	209556	Cale d'épaisseur 5 mm Cala de espesor Spessore - Ausgleichscheibe - Shim -	X	X																		
24	209557	Cale d'épaisseur 5,5 mm Cala de espesor Spessore - Ausgleichscheibe - Shim -	X	X																		
25	51314F203071	Bague Anillo Anello - BÜchse - Bushing -	1	1																		
26	239521	Vis H,M16-150- 35-10.9-ZN8/C Tornillo Vite - Schraube - Screw -	2	2																		

7 AA 74

ESSIEU ARRIERE  
HINTERACHSE  
EJE TRASERO  
REAR AXLE  
PONTE POSTERIORE

MSI 20 / 25 / 30 / 35 T S2-E3  
MSI 20 / 25 / 30 / 35 T BUGGIE S2-E3

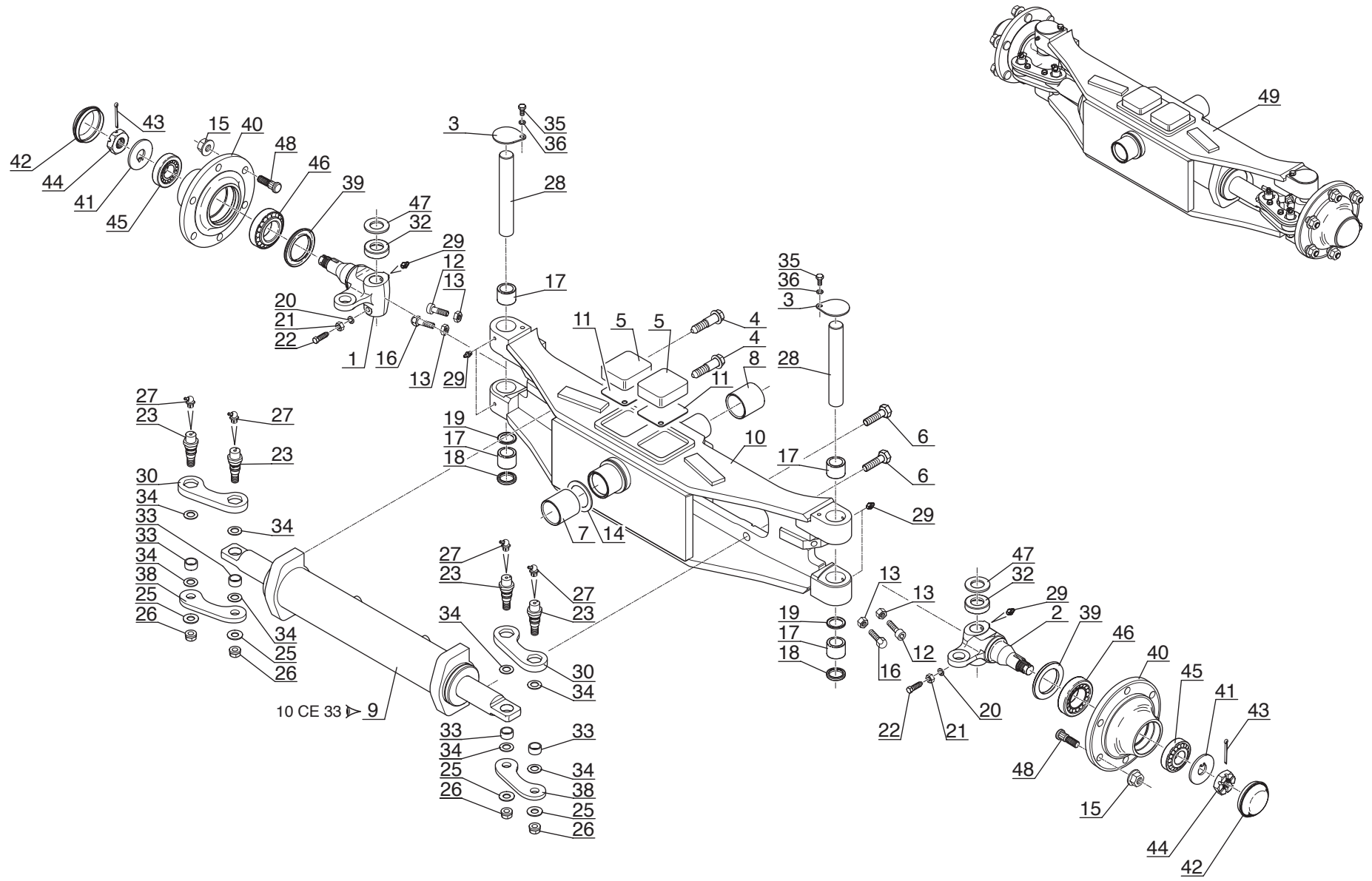



Catalogue : 647000

Qté-Menge-Cant-Qty-Q.ta 7 AA 74 M

1

ESSIEU ARRIERE  
HINTERACHSE  
EJE TRASERO  
REAR AXLE  
PONTE POSTERIORE

1-	MH20-4T BUG. S2-E3	11-
2-	MH25-4T BUG. S2-E3	12-
3-	MSI 20T S2-E3	13-
4-	MSI 20T BUG. S2-E3	14-
5-	MSI 25T S2-E3	15-
6-	MSI 25T BUG. S2-E3	16-
7-	MSI 30T S2-E3	17-
8-	MSI 30T BUG. S2-E3	18-
9-	MSI 35T S2-E3	19-
10-	MSI 35T BUG. S2-E3	20-

Rep Hinw Fig Item Rif	Numéro Teil-Nr Numero Part-Nr Part-Nr	Désignation Bezeichnung Descripcion Description Descrizione	1	2	3	4	5	6	7	8	9	10	11	12	13	14	15	16	17	18	19	20
1	43261F210071	Fusée de direction gauche - Link achsschenkel Mangueta de dirección izquierda L.H. stub axle Fuso di direzione sinistra -			1	1	1	1	1	1	1	1										
2	43251F210071	Fusée de direction droite - Recht achsschenkel Mangueta de dirección derecha - R.H. stub axle Fuso di direzione destra -			1	1	1	1	1	1	1	1										
3	230908	Chapeau - Deckel Tapadera - Cap Capello -			2	2	2	2	2	2	2	2										
4	240457	Vis - Schraube Tornillo - Screw Vite -			2	2	2	2	2	2	2	2										
5	207863	Amortisseur - Dämpfer Amortiguador - Damper Ammortizzatore -			2	2	2	2	2	2	2	2										
6	207865	Vis H,M16-150- 45-10.9-ZN8/C - Schraube Tornillo - Screw Vite -			2	2	2	2	2	2	2	2										
7	51313F203071	Bague - Büchse Anillo - Bushing Anello -			1	1	1	1	1	1	1	1										
8	51314F203071	Bague - Büchse Anillo - Bushing Anello -			1	1	1	1	1	1	1	1										
9	237786	Vérin direction D:45mm C:2x70mm Lenkungszylinder Cilindro de dirección - Steering cylinder Cilindro di sterzo -			1	1	1	1	1	1	1	1										
10	241210	Essieu arrière - Hinterachse Eje trasero - Rear axle Assale posteriore -			1	1	1	1	1	1	1	1										
11	234486	Plaque - Platte Placa - Plate Piastra -			2	2	2	2	2	2	2	2										

+

Catalogue : 647000

2

ESSIEU ARRIERE  
HINTERACHSE  
EJE TRASERO  
REAR AXLE  
PONTE POSTERIORE

Qté-Menge-Cant-Qty-Q.ta

7 AA

74

M

1-	MH20-4T BUG. S2-E3	11-
2-	MH25-4T BUG. S2-E3	12-
3-	MSI 20T S2-E3	13-
4-	MSI 20T BUG. S2-E3	14-
5-	MSI 25T S2-E3	15-
6-	MSI 25T BUG. S2-E3	16-
7-	MSI 30T S2-E3	17-
8-	MSI 30T BUG. S2-E3	18-
9-	MSI 35T S2-E3	19-
10-	MSI 35T BUG. S2-E3	20-

Rep Hinw Fig Item Rif	Numéro Teil-Nr Numero Part-Nr Part-Nr	Désignation Bezeichnung Descripcion Description Descrizione	Qté-Menge-Cant-Qty-Q.ta																			
			1	2	3	4	5	6	7	8	9	10	11	12	13	14	15	16	17	18	19	20
12	61109	Vis CHc,M12- 35-8.8-ZN8/C Tornillo Vite	- Schraube - Screw -			2	2	2	2	2	2	2	2	2								
13	58548	Ecrou H ,M12 C 8 ZN..C Tuerca Dado	- Mutter - Nut -			4	4	4	4	4	4	4	4	4								
14	209552	Cale d'épaisseur 3 mm Cala de espesor Spessore	- Ausgleichscheibe - Shim -			X	X	X	X	X	X	X	X	X								
14	209553	Cale d'épaisseur 3,5 mm Cala de espesor Spessore	- Ausgleichscheibe - Shim -			X	X	X	X	X	X	X	X	X								
14	209554	Cale d'épaisseur 4 mm Cala de espesor Spessore	- Ausgleichscheibe - Shim -			X	X	X	X	X	X	X	X	X								
14	209555	Cale d'épaisseur 4,5 mm Cala de espesor Spessore	- Ausgleichscheibe - Shim -			X	X	X	X	X	X	X	X	X								
14	209556	Cale d'épaisseur 5 mm Cala de espesor Spessore	- Ausgleichscheibe - Shim -			X	X	X	X	X	X	X	X	X								
14	209557	Cale d'épaisseur 5,5 mm Cala de espesor Spessore	- Ausgleichscheibe - Shim -			X	X	X	X	X	X	X	X	X								
15	243006	Ecrou de roue arrière Tuerca de rueda trasera Dado ruote posteriore	- Hinter radmutter - Rear wheel nut -			12	12	12	12	12	12	12	12	12								
16	234958	Vis spéciale bombée Tornillo Vite	- Schraube - Screw -			2	2	2	2	2	2	2	2	2								
17	432282332071	Roulement à aiguilles Rodamiento de agujas Cuscinetto	- Rollenlager - Roller bearing -			4	4	4	4	4	4	4	4	4								

+

Catalogue : 647000

3

ESSIEU ARRIERE  
HINTERACHSE  
EJE TRASERO  
REAR AXLE  
PONTE POSTERIORE

Qté-Menge-Cant-Qty-Q.ta

7 AA

74

M

1-	MH20-4T	BUG. S2-E3	11-
2-	MH25-4T	BUG. S2-E3	12-
3-	MSI 20T	S2-E3	13-
4-	MSI 20T	BUG. S2-E3	14-
5-	MSI 25T	S2-E3	15-
6-	MSI 25T	BUG. S2-E3	16-
7-	MSI 30T	S2-E3	17-
8-	MSI 30T	BUG. S2-E3	18-
9-	MSI 35T	S2-E3	19-
10-	MSI 35T	BUG. S2-E3	20-

Rep Hinw Fig Item Rif	Numéro Teil-Nr Numero Part-Nr Part-Nr	Désignation Bezeichnung Descripcion Description Descrizione	Qté-Menge-Cant-Qty-Q.ta																			
			1	2	3	4	5	6	7	8	9	10	11	12	13	14	15	16	17	18	19	20
18	432332332071	Joint Junta Guarnizióne - Dichtung - Seal -			2	2	2	2	2	2	2	2	2									
19	432422332071	Joint Junta Guarnizióne - Dichtung - Seal -			2	2	2	2	2	2	2	2	2									
20	42232	Rondelle W10 ZN Arandela Rondella - Unterlegscheibe - Washer -			2	2	2	2	2	2	2	2	2									
21	164633	Ecrou H ,M10 Pas 125 zingué Tuerca Dado - Mutter - Nut -			2	2	2	2	2	2	2	2	2									
22	901091001571	Vis Tornillo Vite - Schraube - Screw -			2	2	2	2	2	2	2	2	2									
23	437312344271	Axe de biellette Eje de biela Perno di biella - Stange bolzen - Rod axle -			4	4	4	4	4	4	4	4	4									
25	9461211400	Rondelle Arandela Rondella - Unterlegscheibe - Washer -			4	4	4	4	4	4	4	4	4									
26	901791400271	Ecrou Tuerca Dado - Mutter - Nut -			4	4	4	4	4	4	4	4	4									
27	22254	Graisseur ( 6 x 100C) 45° Engrasador Ingrassatore - Schmiernippel - Greaser -			4	4	4	4	4	4	4	4	4									
28	43232F210171	Axe Eje Perno - Bolzen - Pin -			2	2	2	2	2	2	2	2	2									
29	269	Graisseur Engrasador Ingrassatore - Schmiernippel - Greaser -			6	6	6	6	6	6	6	6	6									

+

Catalogue : 647000

4

ESSIEU ARRIERE  
HINTERACHSE  
EJE TRASERO  
REAR AXLE  
PONTE POSTERIORE

Qté-Menge-Cant-Qty-Q.ta

7 AA

74

M

1- MH20-4T BUG. S2-E3 11-  
2- MH25-4T BUG. S2-E3 12-  
3- MSI 20T S2-E3 13-  
4- MSI 20T BUG. S2-E3 14-  
5- MSI 25T S2-E3 15-  
6- MSI 25T BUG. S2-E3 16-  
7- MSI 30T S2-E3 17-  
8- MSI 30T BUG. S2-E3 18-  
9- MSI 35T S2-E3 19-  
10- MSI 35T BUG. S2-E3 20-

Rep Hinw Fig Item Rif	Numéro Teil-Nr Numero Part-Nr Part-Nr	Désignation Bezeichnung Descripcion Description Descrizione	Qté-Menge-Cant-Qty-Q.ta																			
			1	2	3	4	5	6	7	8	9	10	11	12	13	14	15	16	17	18	19	20
30	437513327071	Biellette Biela Biella - Stange - Rod -			2	2	2	2	2	2	2	2										
32	432291331071	Butée à billes Tope Battuta - Anschlag - Stop -			2	2	2	2	2	2	2	2										
33	437352344071	Bague Anillo Anello - Büchse - Bushing -			4	4	4	4	4	4	4	4										
34	437552344071	Rondelle Arandela Rondella - Unterlegscheibe - Washer -			8	8	8	8	8	8	8	8										
35	54951	Vis H,M 8- 16-8.8-ZN8/C Tornillo Vite - Schraube - Screw -			2	2	2	2	2	2	2	2										
36	208524	Rondelle Z 8 ZN Arandela Rondella - Unterlegscheibe - Washer -			2	2	2	2	2	2	2	2										
38	437522344271	Biellette Biela Biella - Stange - Rod -			2	2	2	2	2	2	2	2										
39	438212200071	Joint Junta Guarnizióne - Dichtung - Seal -			2	2	2	2	2	2	2	2										
40	255879	Moyeu de roue Cubo de rueda Mozzo ruota - Radnabe - Wheel hub -			2	2	2	2	2	2	2	2										
41	431552054071	Rondelle Arandela Rondella - Unterlegscheibe - Washer -			2	2	2	2	2	2	2	2										
42	438152054071	Chapeau de moyeu Tapadera de cubo Capello di mozzo - Radnabenkappe - Wheel hub cap -			2	2	2	2	2	2	2	2										

+

Catalogue : 647000

5

ESSIEU ARRIERE  
HINTERACHSE  
EJE TRASERO  
REAR AXLE  
PONTE POSTERIORE

Qté-Menge-Cant-Qty-Q.ta

7 AA

74

M

1-	MH20-4T	BUG. S2-E3	11-
2-	MH25-4T	BUG. S2-E3	12-
3-	MSI 20T	S2-E3	13-
4-	MSI 20T	BUG. S2-E3	14-
5-	MSI 25T	S2-E3	15-
6-	MSI 25T	BUG. S2-E3	16-
7-	MSI 30T	S2-E3	17-
8-	MSI 30T	BUG. S2-E3	18-
9-	MSI 35T	S2-E3	19-
10-	MSI 35T	BUG. S2-E3	20-

Rep Hinw Fig Item Rif	Numéro Teil-Nr Numero Part-Nr Part-Nr	Désignation Bezeichnung Descripcion Description Descrizione	1	2	3	4	5	6	7	8	9	10	11	12	13	14	15	16	17	18	19	20
43	5302	Goupille V 5 x 50 zinguée - Stift Pasador - Pin Spina -			2	2	2	2	2	2	2	2										
44	206355	Ecrou - Mutter Tuerca - Nut Dado -			2	2	2	2	2	2	2	2										
45	43222F203071	Roulement - Läger Rodamiento - Bearing Cuscinetto -			2	2	2	2	2	2	2	2										
46	43221F203071	Roulement - Läger Rodamiento - Bearing Cuscinetto -			2	2	2	2	2	2	2	2										
47	43221F210071	Rondelle (3 mm) - Unterlegscheibe Arandela - Washer Rondella -			X	X	X	X	X	X	X	X										
47	43222F210071	Rondelle (3,5 mm) - Unterlegscheibe Arandela - Washer Rondella -			X	X	X	X	X	X	X	X										
47	43223F210071	Rondelle (4 mm) - Unterlegscheibe Arandela - Washer Rondella -			X	X	X	X	X	X	X	X										
47	43224F210071	Rondelle (4,5 mm) - Unterlegscheibe Arandela - Washer Rondella -			X	X	X	X	X	X	X	X										
48	255880	Goujon - Stiftschraube Espárrago - Stud-bolt Prigioniero -			12	12	12	12	12	12	12	12										
49	230909	Essieu complet - Kompletter achse Eje completo - Complete axle Assale completo -			1	1	1	1	1	1	1	1										

8 AA 390

SIEGE (Skail)  
SITZ (Synthetisch stoff)  
ASIENTO (Tejido sintético)  
SEAT (Synthetics woven)  
SEDILE (Sky)

MH 20-4 T BUGGIE S2-E3  
MH 25-4 T BUGGIE S2-E3  
MSI 20 / 25 / 30 / 35 T S2-E3  
MSI 20 / 25 / 30 / 35 T BUGGIE S2-E3

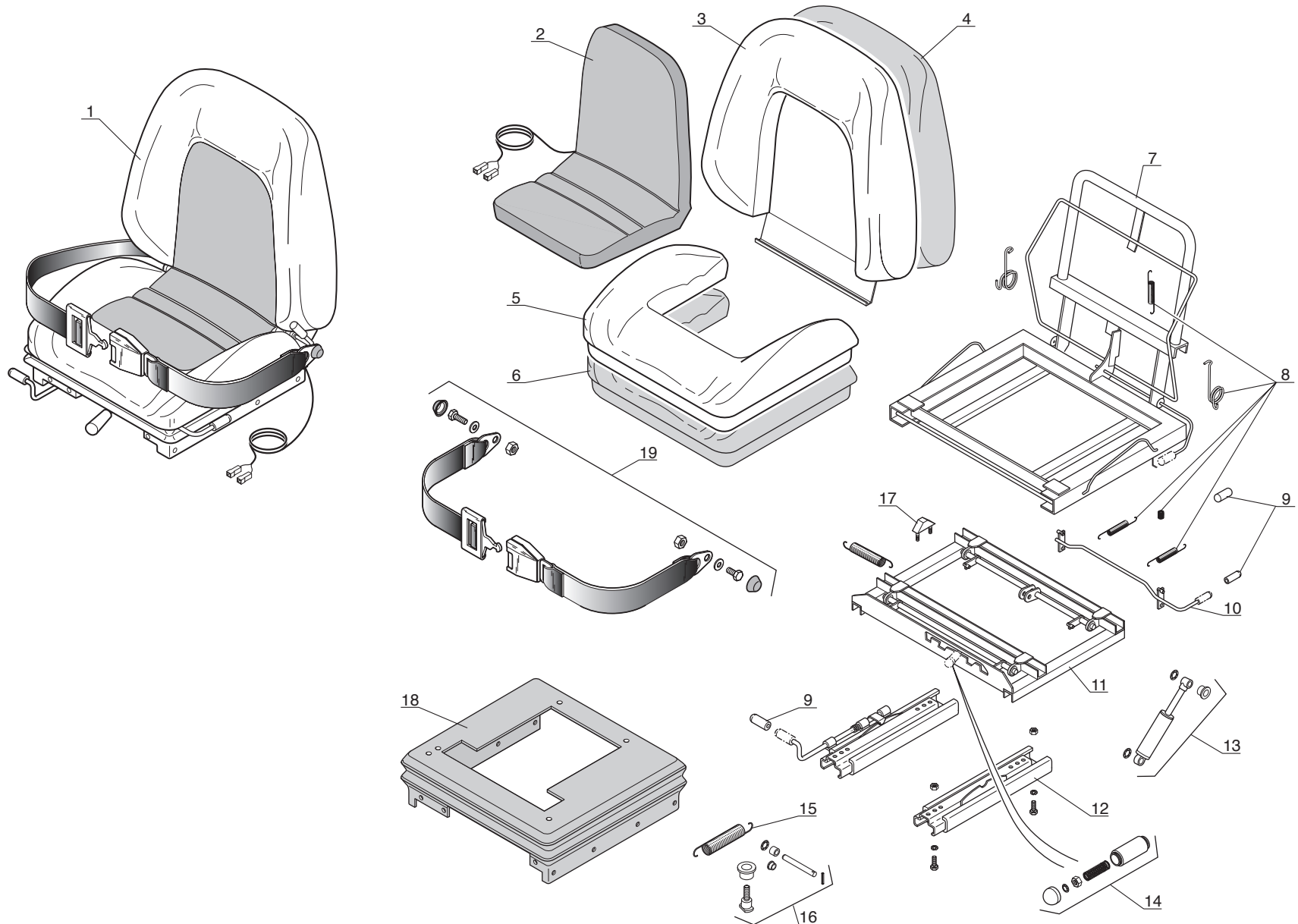

Catalogue : 647000

1

SIEGE (Skai)  
SITZ (Synthetisch stoff)  
ASIENTO (Tejido sintetico)  
SEAT (Synthetics woven)  
SEDILE (In sky)

Qté-Menge-Cant-Qty-Q.ta

8 AA

390

M

1-	MH20-4T	BUG. S2-E3	11-
2-	MH25-4T	BUG. S2-E3	12-
3-	MSI 20T	S2-E3	13-
4-	MSI 20T	BUG. S2-E3	14-
5-	MSI 25T	S2-E3	15-
6-	MSI 25T	BUG. S2-E3	16-
7-	MSI 30T	S2-E3	17-
8-	MSI 30T	BUG. S2-E3	18-
9-	MSI 35T	S2-E3	19-
10-	MSI 35T	BUG. S2-E3	20-

Rep Hinw Fig Item Rif	Numéro Teil-Nr Numero Part-Nr Part-Nr	Désignation Bezeichnung Descripcion Description Descrizione	1	2	3	4	5	6	7	8	9	10	11	12	13	14	15	16	17	18	19	20
1	253003	Siège complet Asiento completo Sedile completo - Kompletter sitz - Complete seat -	1	1	1	1	1	1	1	1	1	1										
2	706118	Coussin complet (avec capteur) Asiento completo Cuscino completo - Kompletter sitz - Seat cushion assembly -	1	1	1	1	1	1	1	1	1	1										
3	561282	Couvre dossier Cubre dorso Copri schienale - Deck rückenlehne - Cover backrest -	1	1	1	1	1	1	1	1	1	1										
4	561283	Mousse Espuma Musco - Schaum - Foam -	1	1	1	1	1	1	1	1	1	1										
5	561284	Couvre siège Cubre asiento Copri sedile - Decke sitz - Cover seat -	1	1	1	1	1	1	1	1	1	1										
6	561285	Mousse Espuma Müsco - Schaum - Foam -	1	1	1	1	1	1	1	1	1	1										
7	561277	Ossature Esqueletto Struttura - Rahmenwerk - Frame work -	1	1	1	1	1	1	1	1	1	1										
8	561289	Kit ressort Kit muelle Kit molla - Kit feder - Spring kit -	1	1	1	1	1	1	1	1	1	1										
9	561293	Kit leviers Kit palanca Kit levi - Kit hebel - Lever kit -	1	1	1	1	1	1	1	1	1	1										
10	561279	Levier (Inclinaison) Palanca (Inclinación) Leva (Inclinazione) - Hebel (Neigung) - Lever (Tilting) -	1	1	1	1	1	1	1	1	1	1										
11	561278	Kit suspension Juego suspension Kit suspensioe - Aufhängung satz - Suspensior kit -	1	1	1	1	1	1	1	1	1	1										

+

Catalogue : 647000

2

SIEGE (Skai)  
 SITZ (Synthetisch stoff)  
 ASIENITO (Tejido sintetico)  
 SEAT (Synthetics woven)  
 SEDILE (In sky)

Qté-Menge-Cant-Qty-Q.ta

8 AA

390

M

1-	MH20-4T	BUG. S2-E3	11-
2-	MH25-4T	BUG. S2-E3	12-
3-	MSI 20T	S2-E3	13-
4-	MSI 20T	BUG. S2-E3	14-
5-	MSI 25T	S2-E3	15-
6-	MSI 25T	BUG. S2-E3	16-
7-	MSI 30T	S2-E3	17-
8-	MSI 30T	BUG. S2-E3	18-
9-	MSI 35T	S2-E3	19-
10-	MSI 35T	BUG. S2-E3	20-

Rep Hinw Fig Item Rif	Numéro Teil-Nr Numero Part-Nr Part-Nr	Désignation Bezeichnung Descripcion Description Descrizione																				
			1	2	3	4	5	6	7	8	9	10	11	12	13	14	15	16	17	18	19	20
12	561281	Kit glissière Juego de deslizadera Kit slitta - Gleitschiene satz - Fore and alt adjustment kit -	1	1	1	1	1	1	1	1	1	1										
13	561287	Kit amortisseur Juego amortiguador Kit ammortizzatore - Stossdämpfer - Damper assembly kit -	1	1	1	1	1	1	1	1	1	1										
14	561288	Kit réglage suspension Kit reglaje suspensión Kit regolazione suspensioe - Kit aufhängung verstell bar - Suspension adjuster kit -	1	1	1	1	1	1	1	1	1	1										
15	561292	Ressort Muelle Molla - Feder - Spring -	1	1	1	1	1	1	1	1	1	1										
16	561291	Kit axe Kit eje Kit perno - Kit achse - Pin kit -	1	1	1	1	1	1	1	1	1	1										
17	561290	Butée Tope Battuta - Anschlag - Stop -	1	1	1	1	1	1	1	1	1	1										
18	561280	Soufflet Fuelle Soffietto - Blasebalg - Bellows -	1	1	1	1	1	1	1	1	1	1										
19	563824	Ceinture de sécurité Cinturon de seguridad Cintura di sigurezza - Sitz Gurt - Seat belt -	1	1	1	1	1	1	1	1	1	1										





8 AA 604

ADAPTATION SIEGE  
SITZ ANPASSUNG  
ADAPTACION ASIENTO  
SEAT ADAPTATION  
ADATTAMENTO SEDILE

MH 20-4 T BUGGIE S2-E3  
MH 25-4 T BUGGIE S2-E3  
MSI 20 / 25 / 30 / 35 T S2-E3  
MSI 20 / 25 / 30 / 35 T BUGGIE S2-E3

MSI 20 / 25 / 30 / 35 T S2-E3

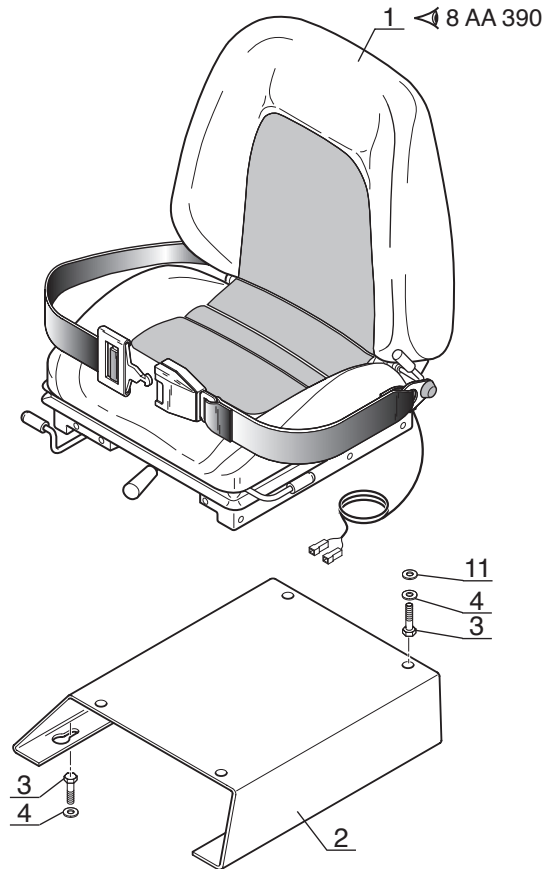

MSI 20 / 25 / 30 / 35 T BUGGIE S2-E3  
MH 20-4T BUGGIE / MH 25-4T BUGGIE S2-E3

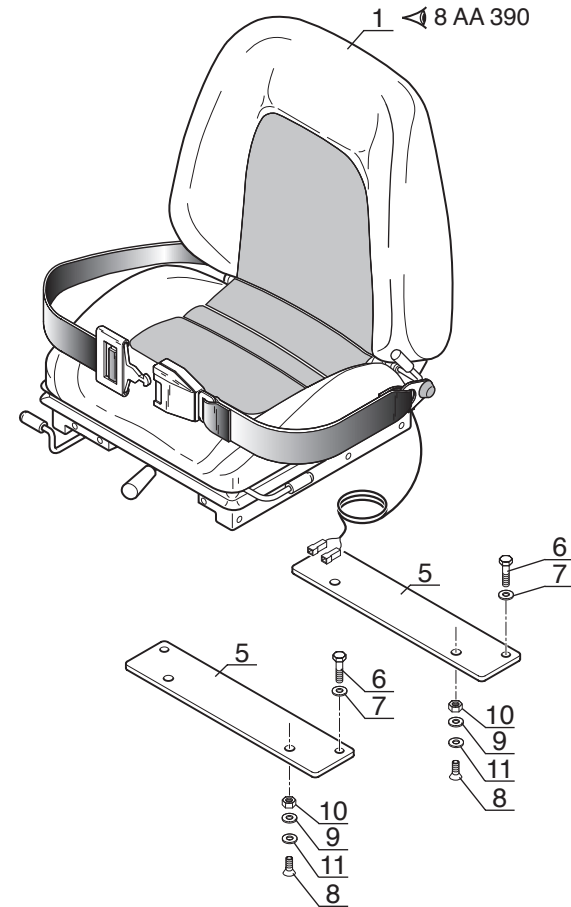

Catalogue : 647000

1	ADAPTATION SIEGE SITZ ANPASSUNG ADAPTACION ASIEN TO SEAT ADAPTATION ADATTAMENTO SEDILE			Qté-Menge-Cant-Qty-Q.ta										8 AA		604		M					
	Rep Hinw Fig Item Rif	Numéro Teil-Nr Numero Part-Nr Part-Nr	Désignation Bezeichnung Descripcion Description Descrizione	1	2	3	4	5	6	7	8	9	10	11	12	13	14		15	16	17	18	19
1	253003	Siège complet Asiento completo Sedile completo	- Kompletter sitz - Complete seat -	1	1	1	1	1	1	1	1	1	1										
2	216478	Support siège Soporte asiento Supporto sedile	- Sitz träger - Seat bracket -			1		1		1		1											
3	42347	Vis H,M 8- 20-8.8-ZN8/C Tornillo Vite	- Schraube - Screw -			8		8		8		8											
4	208524	Rondelle Z 8 ZN Arandela Rondella	- Unterlegscheibe - Washer -			8		8		8		8											
5	216475	Support Soporte Supporto	- Träger - Bracket -	2	2		2		2		2		2										
6	42347	Vis H,M 8- 20-8.8-ZN8/C Tornillo Vite	- Schraube - Screw -	4	4		4		4		4		4										
7	208524	Rondelle Z 8 ZN Arandela Rondella	- Unterlegscheibe - Washer -	4	4		4		4		4		4										
8	42412	Vis FHc,M 8- 20-10.9-ZN8/C Tornillo Vite	- Schraube - Screw -	4	4		4		4		4		4										
9	61674	Rondelle M 8 ZN Arandela Rondella	- Unterlegscheibe - Washer -	4	4		4		4		4		4										
10	58528	Ecrou H ,M 8 ZN Tuerca Dado	- Mutter - Nut -	4	4		4		4		4		4										
11	42366	Rondelle SP 10,5x 30 x 3 ZN Arandela Rondella	- Unterlegscheibe - Washer -	4	4	4	4	4	4	4	4	4	4	4									

# 8 AA 605

ADAPTATION CABINE  
 KABINE ANPASSUNG  
 ADAPTACION CABINA  
 CAB ADAPTATION  
 ADATTAMENTO CABINA

MH 20-4 T BUGGIE S2-E3  
 MH 25-4 T BUGGIE S2-E3  
 MSI 20 / 25 / 30 / 35 T S2-E3  
 MSI 20 / 25 / 30 / 35 T BUGGIE S2-E3

● SEULEMENT POUR - NUR FÜR  
 SOLAMENTE PARA - ONLY FOR - SOLO PER

MSI 20 / 25 / 30 / 35 T S2-E3

○ SEULEMENT POUR - NUR FÜR  
 SOLAMENTE PARA - ONLY FOR - SOLO PER

MSI 20 / 25 / 30 / 35 T BUGGIE S2-E3  
 MH 20-4 / 25-4 T BUGGIE S2-E3

□ SEULEMENT POUR - NUR FÜR  
 SOLAMENTE PARA - ONLY FOR - SOLO PER

MSI 20 / 25 / 30 / 35 T S2-E3  
 MSI 20 / 25 / 30 / 35 T BUGGIE S2-E3

■ SEULEMENT POUR - NUR FÜR  
 SOLAMENTE PARA - ONLY FOR - SOLO PER

MH 20-4 / 25-4 T BUGGIE S2-E3

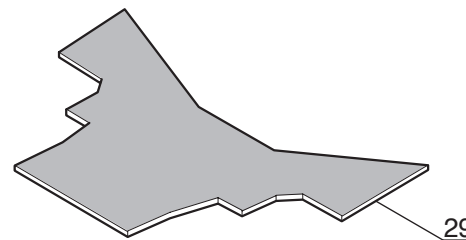
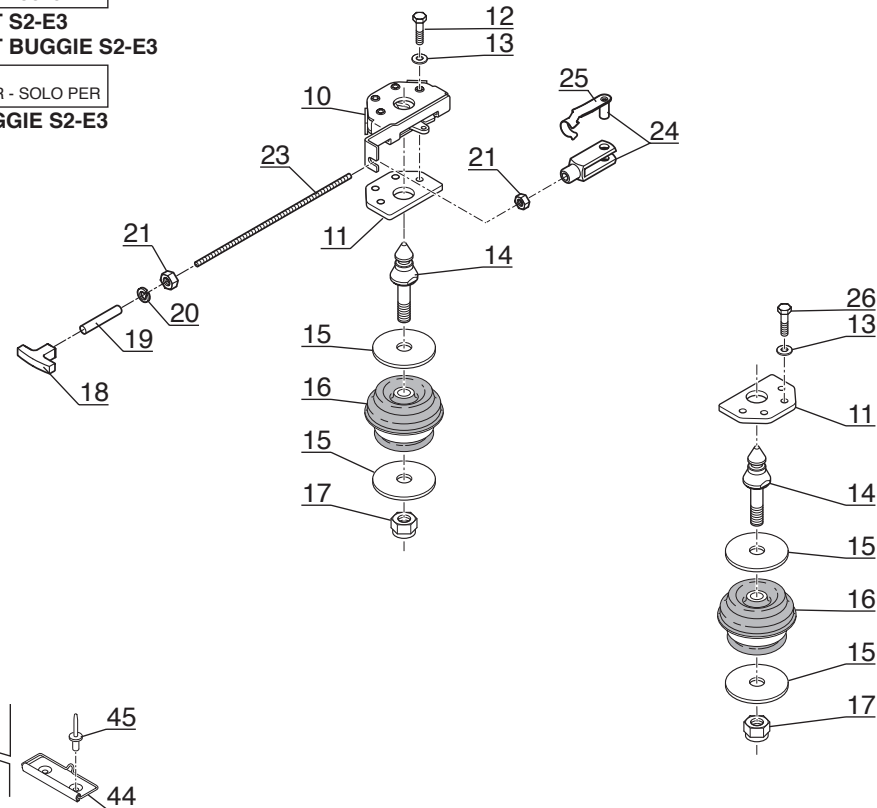
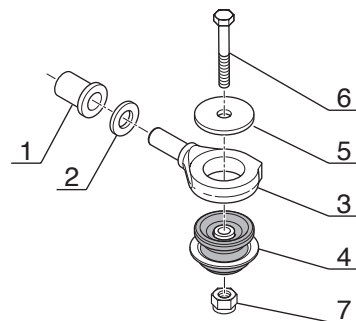
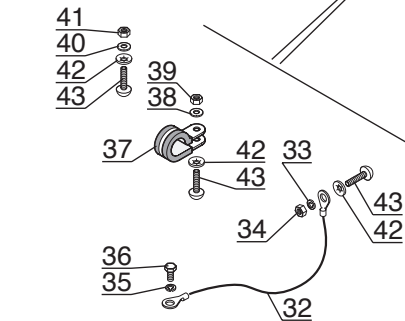
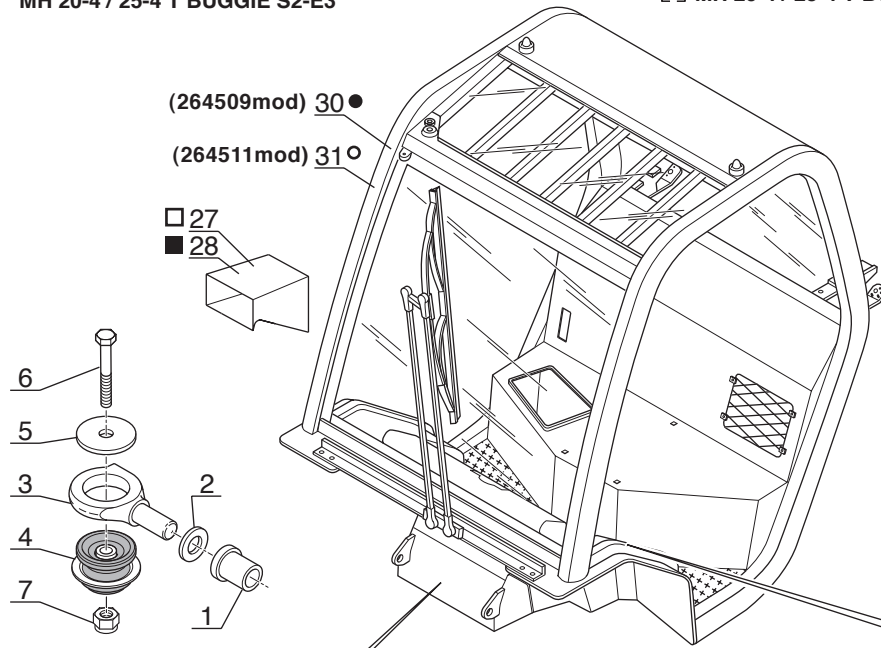

Catalogue : 647000

Qté-Menge-Cant-Qty-Q.ta | 8 AA 605 M

1  
ADAPTATION PROTECTEUR  
SCHUTZ ANPASSUNG  
ADAPTACION PROTECTOR  
PROTECTOR ADAPTATION  
ADATTAMENTO PROTEZIONE

1-	MH20-4T	BUG. S2-E3	11-
2-	MH25-4T	BUG. S2-E3	12-
3-	MSI 20T	S2-E3	13-
4-	MSI 20T	BUG. S2-E3	14-
5-	MSI 25T	S2-E3	15-
6-	MSI 25T	BUG. S2-E3	16-
7-	MSI 30T	S2-E3	17-
8-	MSI 30T	BUG. S2-E3	18-
9-	MSI 35T	S2-E3	19-
10-	MSI 35T	BUG. S2-E3	20-

Rep Hinw Fig Item Rif	Numéro Teil-Nr Numero Part-Nr Part-Nr	Désignation Bezeichnung Descripcion Description Descrizione
-----------------------------------	---	---

1	2	3	4	5	6	7	8	9	10	11	12	13	14	15	16	17	18	19	20
---	---	---	---	---	---	---	---	---	----	----	----	----	----	----	----	----	----	----	----

1	210005	Bague Anillo Anello - Büchse - Bushing -
2	202947	Rondelle Z30 ZN Arandela Rondella - Unterlegscheibe - Washer -
3	207783	Palier Cojinete Cuscinetti - Lager - Bearing -
4	209113	Silentbloc Amortiguador Tasselo - Dampfer - Shock absorber -
5	210006	Rondelle HR21 x 90x5 ZN Arandela Rondella - Unterlegscheibe - Washer -
6	58630	Vis H,M20-100-8.8-ZN8/C Tornillo Vite - Schraube - Screw -
7	185054	Ecrou H,FR M20 zingué Tuerca Dado - Mutter - Nut -
10	216422	Verrou droit Cerrojo derecho Catenaccio destro - Recht riegel - R.H. locker -
11	216337	Plaque entretoise Placa separador Piastra distanziale - Strebesplatte - Strut plate -
12	31003	Vis H,M10- 60-8.8-ZN8/C Tornillo Vite - Schraube - Screw -
13	29437	Rondelle M 10 ZN Arandela Rondella - Unterlegscheibe - Washer -

2	2	2	2	2	2	2	2	2	2										
2	2	2	2	2	2	2	2	2	2										
2	2	2	2	2	2	2	2	2	2										
2	2	2	2	2	2	2	2	2	2										
2	2	2	2	2	2	2	2	2	2										
2	2	2	2	2	2	2	2	2	2										
2	2	2	2	2	2	2	2	2	2										
1	1	1	1	1	1	1	1	1	1										
2	2	2	2	2	2	2	2	2	2										
4	4	4	4	4	4	4	4	4	4										
6	6	6	6	6	6	6	6	6	6										



Catalogue : 647000

2

ADAPTATION PROTECTEUR  
 SCHUTZ ANPASSUNG  
 ADAPTACION PROTECTOR  
 PROTECTOR ADAPTATION  
 ADATTAMENTO PROTEZIONE

Qté-Menge-Cant-Qty-Q.ta

8 AA

605

M

1-	MH20-4T	BUG. S2-E3	11-
2-	MH25-4T	BUG. S2-E3	12-
3-	MSI 20T	S2-E3	13-
4-	MSI 20T	BUG. S2-E3	14-
5-	MSI 25T	S2-E3	15-
6-	MSI 25T	BUG. S2-E3	16-
7-	MSI 30T	S2-E3	17-
8-	MSI 30T	BUG. S2-E3	18-
9-	MSI 35T	S2-E3	19-
10-	MSI 35T	BUG. S2-E3	20-

Rep Hinw Fig Item Rif	Numéro Teil-Nr Numero Part-Nr Part-Nr	Désignation Bezeichnung Descripcion Description Descrizione	1	2	3	4	5	6	7	8	9	10	11	12	13	14	15	16	17	18	19	20
14	216316	Axe Eje Perno - Bolzen - Pin -	2	2	2	2	2	2	2	2	2	2										
15	210006	Rondelle HR21 x 90x5 ZN Arandela Rondella - Unterlegscheibe - Washer -	4	4	4	4	4	4	4	4	4	4										
16	209113	Silentbloc Amortiguador Tasselo - Dampfer - Shock absorber -	2	2	2	2	2	2	2	2	2	2										
17	185054	Ecrou H,FR M20 zingué Tuerca Dado - Mutter - Nut -	2	2	2	2	2	2	2	2	2	2										
18	251791	Poignée Agarrador Maniglia - Handgriff - Handle -	1	1	1	1	1	1	1	1	1	1										
19	222362	Tube (Lg 35) Tubo Tubo - Rohr - Tube -	1	1	1	1	1	1	1	1	1	1										
20	42316	Rondelle W 6 ZN Arandela Rondella - Unterlegscheibe - Washer -	1	1	1	1	1	1	1	1	1	1										
21	25714	Ecrou H ,M 6 ZN Tuerca Dado - Mutter - Nut -	2	2	2	2	2	2	2	2	2	2										
23	252857	Tige filetée Varilla fileteada Stelo filettato - Gewindestange - Screwed spindle -	1	1	1	1	1	1	1	1	1	1										
24	169994	Chape complète Abrazadera completa Forchetta completa - Kompletter gabelgelenk - Complete fork joint -	1	1	1	1	1	1	1	1	1	1										
25	174835	Axe Eje Perno - Bolzen - Pin -	1	1	1	1	1	1	1	1	1	1										

+

Catalogue : 647000

3	ADAPTATION PROTECTEUR SCHUTZ ANPASSUNG ADAPTACION PROTECTOR PROTECTOR ADAPTATION ADATTAMENTO PROTEZIONE			Qté-Menge-Cant-Qty-Q.ta							8 AA		605					M					
	Rep Hinw Fig Item Rif	Numéro Teil-Nr Numero Part-Nr Part-Nr	Désignation Bezeichnung Descripcion Description Descrizione	1	2	3	4	5	6	7	8	9	10	11	12	13	14		15	16	17	18	19
				1- MH20-4T BUG. S2-E3	11-																		
				2- MH25-4T BUG. S2-E3	12-																		
				3- MSI 20T S2-E3	13-																		
				4- MSI 20T BUG. S2-E3	14-																		
				5- MSI 25T S2-E3	15-																		
				6- MSI 25T BUG. S2-E3	16-																		
				7- MSI 30T S2-E3	17-																		
				8- MSI 30T BUG. S2-E3	18-																		
				9- MSI 35T S2-E3	19-																		
				10- MSI 35T BUG. S2-E3	20-																		
26	5804	Vis H,M10- 25-8.8-ZN8/C Tornillo Vite	- Schraube - Screw -	2	2	2	2	2	2	2	2	2	2										
27	264520	Console Consola Consolle	- Konsole - Console -			1	1	1	1	1	1	1	1										
28	264734	Console Consola Consolle	- Konsole - Console -	1	1																		
29	215544	Tapis de sol Colchoneta dura Pedana	- Teppich - Carpet -	1	1	1	1	1	1	1	1	1	1										
30	264509	Protège-conducteur Protector conductor Protezione conducente	- Führer schutzvorrichtung - Driver's overhead guard -			1	1	1	1	1	1	1											
31	264511	Protège-conducteur Protector conductor Protezione conducente	- Führer schutzvorrichtung - Driver's overhead guard -	1	1	1	1	1	1	1	1	1											
32	245605	Câble masse Cable de tierra Cavo di massa	- Massekabel - Earth cable -	1	1	1	1	1	1	1	1	1	1										
33	42325	Rondelle W 8 ZN Arandela Rondella	- Unterlegscheibe - Washer -	1	1	1	1	1	1	1	1	1	1										
34	58528	Ecrou H ,M 8 ZN Tuerca Dado	- Mutter - Nut -	1	1	1	1	1	1	1	1	1	1										
35	42325	Rondelle W 8 ZN Arandela Rondella	- Unterlegscheibe - Washer -	1	1	1	1	1	1	1	1	1	1										
36	54951	Vis H,M 8- 16-8.8-ZN8/C Tornillo Vite	- Schraube - Screw -	1	1	1	1	1	1	1	1	1	1										

+

Catalogue : 647000

4

ADAPTATION PROTECTEUR  
SCHUTZ ANPASSUNG  
ADAPTACION PROTECTOR  
PROTECTOR ADAPTATION  
ADATTAMENTO PROTEZIONE

Qté-Menge-Cant-Qty-Q.ta

8 AA

605

M

1- MH20-4T BUG. S2-E3 11-  
2- MH25-4T BUG. S2-E3 12-  
3- MSI 20T S2-E3 13-  
4- MSI 20T BUG. S2-E3 14-  
5- MSI 25T S2-E3 15-  
6- MSI 25T BUG. S2-E3 16-  
7- MSI 30T S2-E3 17-  
8- MSI 30T BUG. S2-E3 18-  
9- MSI 35T S2-E3 19-  
10- MSI 35T BUG. S2-E3 20-

Rep Hinw Fig Item Rif	Numéro Teil-Nr Numero Part-Nr Part-Nr	Désignation Bezeichnung Description Descrizione	1	2	3	4	5	6	7	8	9	10	11	12	13	14	15	16	17	18	19	20
37	176926	Collier Abrazadera Fascetta - Spannschelle - Clamp -	1	1	1	1	1	1	1	1	1	1	1									
38	61674	Rondelle M 8 ZN Arandela Rondella - Unterlegscheibe - Washer -	1	1	1	1	1	1	1	1	1	1	1									
39	58528	Ecrou H ,M 8 ZN Tuerca Dado - Mutter - Nut -	1	1	1	1	1	1	1	1	1	1	1									
40	61674	Rondelle M 8 ZN Arandela Rondella - Unterlegscheibe - Washer -	1	1	1	1	1	1	1	1	1	1	1									
41	58528	Ecrou H ,M 8 ZN Tuerca Dado - Mutter - Nut -	1	1	1	1	1	1	1	1	1	1	1									
42	197472	Rondelle Arandela Rondella - Unterlegscheibe - Washer -	3	3	3	3	3	3	3	3	3	3	3									
43	202418	Vis CBHc,M 8- 25-ZN NOIRE Tornillo Vite - Schraube - Screw -	3	3	3	3	3	3	3	3	3	3	3									
44	532082300071	Pince à papier Pinza de papel Pinza - Papierklemme - Paper clamp -	1	1	1	1	1	1	1	1	1	1	1									
45	160318	Rivet Remache Rivetto - Niete - Rivet -	2	2	2	2	2	2	2	2	2	2	2									





8 AA 606

ADAPTATION CABINE  
KABINE ANPASSUNG  
ADAPTACION CABINA  
CAB ADAPTATION  
ADATTAMENTO CABINA

MH 20-4 T BUGGIE S2-E3  
MH 25-4 T BUGGIE S2-E3  
MSI 20 / 25 / 30 / 35 T S2-E3  
MSI 20 / 25 / 30 / 35 T BUGGIE S2-E3

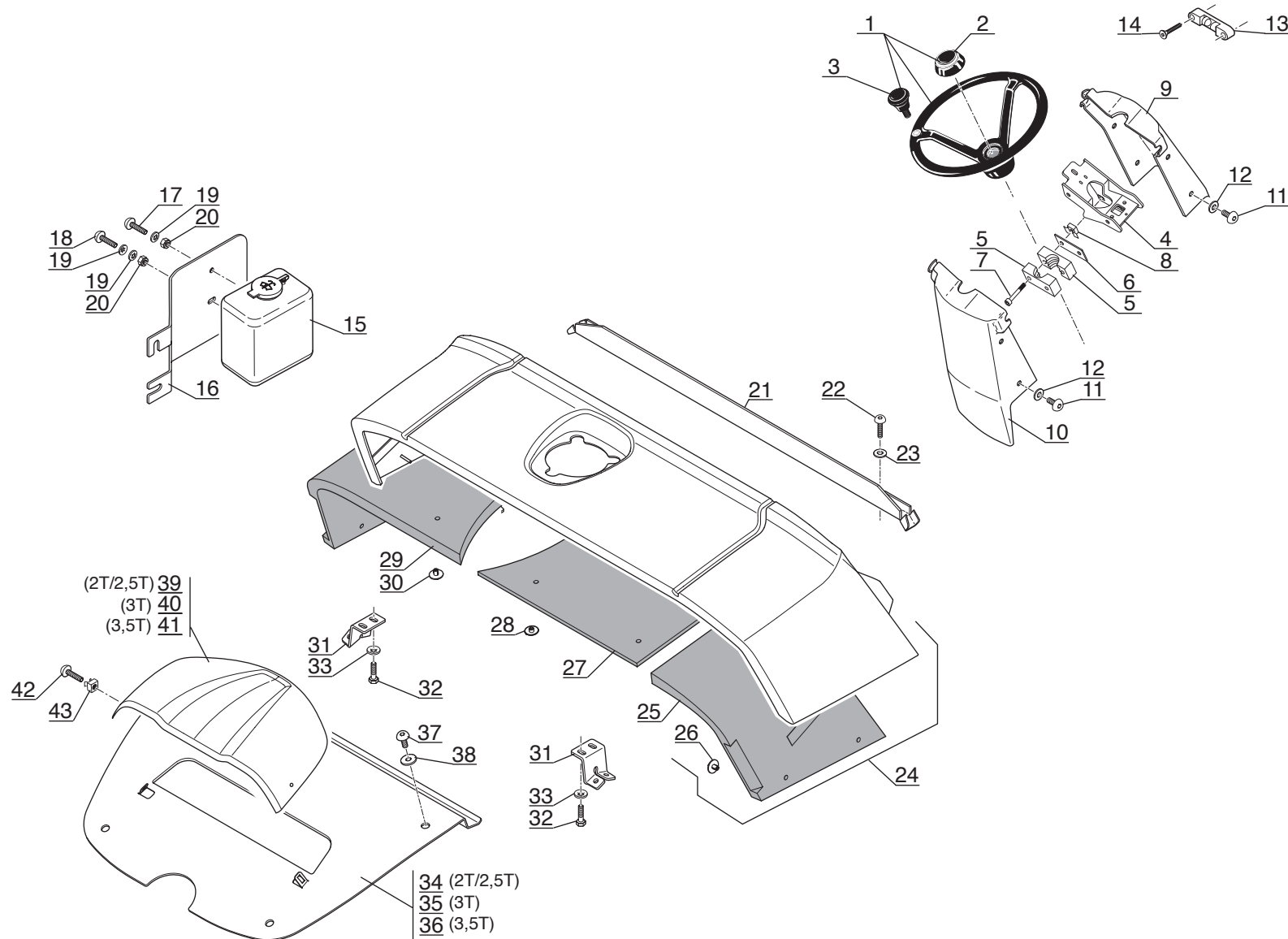

Catalogue : 647000

Qté-Menge-Cant-Qty-Q.ta

8 AA

606

M

1

ADAPTATION CABINE  
KABINE ANPASSUNG  
ADAPTACION CABINA  
CAB ADAPTATION  
ADATTAMENTO CABINA

1- MH20-4T BUG. S2-E3 11-  
2- MH25-4T BUG. S2-E3 12-  
3- MSI 20T S2-E3 13-  
4- MSI 20T BUG. S2-E3 14-  
5- MSI 25T S2-E3 15-  
6- MSI 25T BUG. S2-E3 16-  
7- MSI 30T S2-E3 17-  
8- MSI 30T BUG. S2-E3 18-  
9- MSI 35T S2-E3 19-  
10- MSI 35T BUG. S2-E3 20-

Rep Hinw Fig Item Rif	Numéro Teil-Nr Numero Part-Nr Part-Nr	Désignation Bezeichnung Descripcion Description Descrizione	1	2	3	4	5	6	7	8	9	10	11	12	13	14	15	16	17	18	19	20
1	252759	Volant de direction - Lenkrad Volante de direccion - Steering wheel Volante sterzo -	1	1	1	1	1	1	1	1	1	1										
2	705728	Chapeau de volant - Lenkradkappe Tapadera de volante - Steering wheel cap Capello sterzo -	1	1	1	1	1	1	1	1	1	1										
3	191358	Boule de volant - Lenkrad knopf Bola de volante - Steering wheel ball Bulbo sterzo -	1	1	1	1	1	1	1	1	1	1										
4	203115	Support commutateur d'éclairage Beleuchtungschalter träger Soporte conmutador de luces - Lighting switch bracket Supporto commutatore di illuminazione	1	1	1	1	1	1	1	1	1	1										
5	174321	Demi-collier Ø38 - Halb-klemme Media abrazadera - Half-clamp Fascetta -	2	2	2	2	2	2	2	2	2	2										
6	168870	Plaque de protection - Schützplatte Placa de protección - Protection plate Piastra di protezione -	X	X	X	X	X	X	X	X	X	X										
7	165919	Vis H,M 6- 80-8.8-ZN5/C - Schraube Tornillo - Screw Vite -	2	2	2	2	2	2	2	2	2	2										
8	204665	Ecrou EQC M 6 D zingué - Mutter Tuerca - Nut Dado -	2	2	2	2	2	2	2	2	2	2										
9	202953	Cache colonne de direction (Avant) Lenksäule deckplatte (Vorn) Funda columna de dirección (Delantero) Steering column cover plate (Front) Coperchio colonna sterzo (Anteriore)	1	1	1	1	1	1	1	1	1	1										
10	202954	Cache colonne de direction (Arrière) Lenksäule deckplatte (Hinte) Funda columna de dirección (Trasero) Steering column cover plate (Rear) Coperchio colonna sterzo (Posteriore)	1	1	1	1	1	1	1	1	1	1										

+

Catalogue : 647000

2

ADAPTATION CABINE  
KABINE ANPASSUNG  
ADAPTACION CABINA  
CAB ADAPTATION  
ADATTAMENTO CABINA

Qté-Menge-Cant-Qty-Q.ta

8 AA

606

M

1-	MH20-4T	BUG. S2-E3	11-
2-	MH25-4T	BUG. S2-E3	12-
3-	MSI 20T	S2-E3	13-
4-	MSI 20T	BUG. S2-E3	14-
5-	MSI 25T	S2-E3	15-
6-	MSI 25T	BUG. S2-E3	16-
7-	MSI 30T	S2-E3	17-
8-	MSI 30T	BUG. S2-E3	18-
9-	MSI 35T	S2-E3	19-
10-	MSI 35T	BUG. S2-E3	20-

Rep Hinw Fig Item Rif	Numéro Teil-Nr Numero Part-Nr Part-Nr	Désignation Bezeichnung Descripcion Description Descrizione	1	2	3	4	5	6	7	8	9	10	11	12	13	14	15	16	17	18	19	20	
11	196951	Vis CBHc,M 6- 12-10.9-ZN5/NOIR- Schraube Tornillo - Screw Vite -	8	8	8	8	8	8	8	8	8	8											
12	189857	Rondelle M 6 ZN PASS.NOIRE - Unterlegscheibe Arandela - Washer Rondella -	8	8	8	8	8	8	8	8	8	8											
13	448834	Niveau à bulle d'air - Libelle Nivel de aire - Tubular spirit level Livello a bolla d'aria -	1	1	1	1	1	1	1	1	1	1											
14	191113	Vis FHc,M 4- 25-10.9-ZN5/C - Schraube Tornillo - Screw Vite -	2	2	2	2	2	2	2	2	2	2											
15	551450	Réservoir lave-glace - Scheibenwaser behälter Depósito lavaparabrissas - Windshield-washer tank Serbatoio di lavavetro -	1	1	1	1	1	1	1	1	1	1											
16	274320	Support - Halter Soporte - Bracket Supporto -	1	1	1	1	1	1	1	1	1	1											
17	196951	Vis CBHc,M 6- 12-10.9-ZN5/NOIR- Schraube Tornillo - Screw Vite -	1	1	1	1	1	1	1	1	1	1											
18	189172	Vis CBHc,M 6- 16-10.9-ZN5/NOIR- Schraube Tornillo - Screw Vite -	1	1	1	1	1	1	1	1	1	1											
19	174132	Rondelle JZC 6 CAD.BICH - Unterlegscheibe Arandela - Washer Rondella -	3	3	3	3	3	3	3	3	3	3											
20	162229	Ecrou H,FR M 6 C 8 ZN..C - Mutter Tuerca - Nut Dado -	2	2	2	2	2	2	2	2	2	2											
21	216503	Gouttière - Dachrinne Vierteaguas - Drain trough Grondaia -	1	1	1	1	1	1	1	1	1	1											

+

Catalogue : 647000

3	ADAPTATION CABINE KABINE ANPASSUNG ADAPTACION CABINA CAB ADAPTATION ADATTAMENTO CABINA			Qté-Menge-Cant-Qty-Q.ta							8 AA		606		M								
	Rep Hinw Fig Item Rif	Numéro Teil-Nr Numero Part-Nr Part-Nr	Désignation Bezeichnung Descripcion Description Descrizione	1	2	3	4	5	6	7	8	9	10	11	12	13	14	15	16	17	18	19	20
				1- MH20-4T BUG. S2-E3	11-																		
				2- MH25-4T BUG. S2-E3	12-																		
				3- MSI 20T S2-E3	13-																		
				4- MSI 20T BUG. S2-E3	14-																		
				5- MSI 25T S2-E3	15-																		
				6- MSI 25T BUG. S2-E3	16-																		
				7- MSI 30T S2-E3	17-																		
				8- MSI 30T BUG. S2-E3	18-																		
				9- MSI 35T S2-E3	19-																		
				10- MSI 35T BUG. S2-E3	20-																		
22	202144	Vis CBHc,M 8- 20-10.9-ZN8/NOIR- Tornillo Vite	Schraube - Screw -	2	2	2	2	2	2	2	2	2	2										
23	29468	Rondelle L 8 ZN12C/FE Arandela Rondella	- Unterlegscheibe - Washer -	2	2	2	2	2	2	2	2	2	2										
24	274834	Capot Capot Cofano	- Haube - Bonnet -	1	1	1	1	1	1	1	1	1	1										
25	274738	Insonorisant droit Insonorizador derecho Ammortizzatore destro	- Recht schalldämpfungmoos - R.H. sound proofing foam -	1	1	1	1	1	1	1	1	1	1										
26	241391	Clip Clip Fermaglio	- Klammer - Clip -	4	4	4	4	4	4	4	4	4	4										
27	274748	Insonorisant central Insonorizador central Ammortizzatore centrale	- Zentral Schalldämpfungmoos - Central sound proofing foam -	1	1	1	1	1	1	1	1	1	1										
28	243258	Clip Clip Fermaglio	- Klammer - Clip -	4	4	4	4	4	4	4	4	4	4										
29	274742	Insonorisant gauche Insonorizador izquierdo Ammortizzatore sinistro	- Link schalldämpfungmoos - L.H. sound proofing foam -	1	1	1	1	1	1	1	1	1	1										
30	241391	Clip Clip Fermaglio	- Klammer - Clip -	4	4	4	4	4	4	4	4	4	4										
31	248584	Support Soporte Supporto	- Träger - Bracket -	2	2	2	2	2	2	2	2	2	2										
32	42347	Vis H,M 8- 20-8.8-ZN8/C Tornillo Vite	- Schraube - Screw -	4	4	4	4	4	4	4	4	4	4										

+

Catalogue : 647000

4

ADAPTATION CABINE  
KABINE ANPASSUNG  
ADAPTACION CABINA  
CAB ADAPTATION  
ADATTAMENTO CABINA

Qté-Menge-Cant-Qty-Q.ta

8 AA

606

M

1-	MH20-4T	BUG. S2-E3	11-
2-	MH25-4T	BUG. S2-E3	12-
3-	MSI 20T	S2-E3	13-
4-	MSI 20T	BUG. S2-E3	14-
5-	MSI 25T	S2-E3	15-
6-	MSI 25T	BUG. S2-E3	16-
7-	MSI 30T	S2-E3	17-
8-	MSI 30T	BUG. S2-E3	18-
9-	MSI 35T	S2-E3	19-
10-	MSI 35T	BUG. S2-E3	20-

Rep Hinw Fig Item Rif	Numéro Teil-Nr Numero Part-Nr Part-Nr	Désignation Bezeichnung Descripcion Description Descrizione	Qté-Menge-Cant-Qty-Q.ta																			
			1	2	3	4	5	6	7	8	9	10	11	12	13	14	15	16	17	18	19	20
33	63351	Rondelle JZC 8 CAD.BICH Arandela Rondella	- Unterlegscheibe - Washer -	4	4	4	4	4	4	4	4	4	4	4								
34	273519	Calandre Calandra Calandra	- Verkleidung - Cowl -	1	1	1	1	1	1													
35	273486	Calandre Calandra Calandra	- Verkleidung - Cowl -							1	1											
36	271227	Calandre Calandra Calandra	- Verkleidung - Cowl -									1	1									
37	198433	Vis CBHc,M10- 20 zinguée Tornillo Vite	- Schraube - Screw -	4	4	4	4	4	4	4	4	4	4	4								
38	217556	Rondelle SP 10,5x 30 x 3 ZN Arandela Rondella	- Unterlegscheibe - Washer -	4	4	4	4	4	4	4	4	4	4	4								
39	272245	Défecteur Deflector Defflettore	- Ableitbech - Vent window -	1	1	1	1	1	1													
40	272247	Défecteur Deflector Defflettore	- Ableitbech - Vent window -							1	1											
41	272246	Défecteur Deflector Defflettore	- Ableitbech - Vent window -										1	1								
42	196951	Vis CBHc,M 6- 12-10.9-ZN5/NOIR- Tornillo Vite	- Schraube - Screw -	3	3	3	3	3	3	3	3	3	3	3								
43	178125	Ecrou EQC M 6 C Tuerca Dado	- Mutter - Nut -	3	3	3	3	3	3	3	3	3	3	3								



8 AA 607

GARDE-BOUE  
KÜHLERSPRITZBLECH  
GUARDADARROS  
SPASH APRON  
PARAFANGO

MH 20-4 T BUGGIE S2-E3  
MH 25-4 T BUGGIE S2-E3

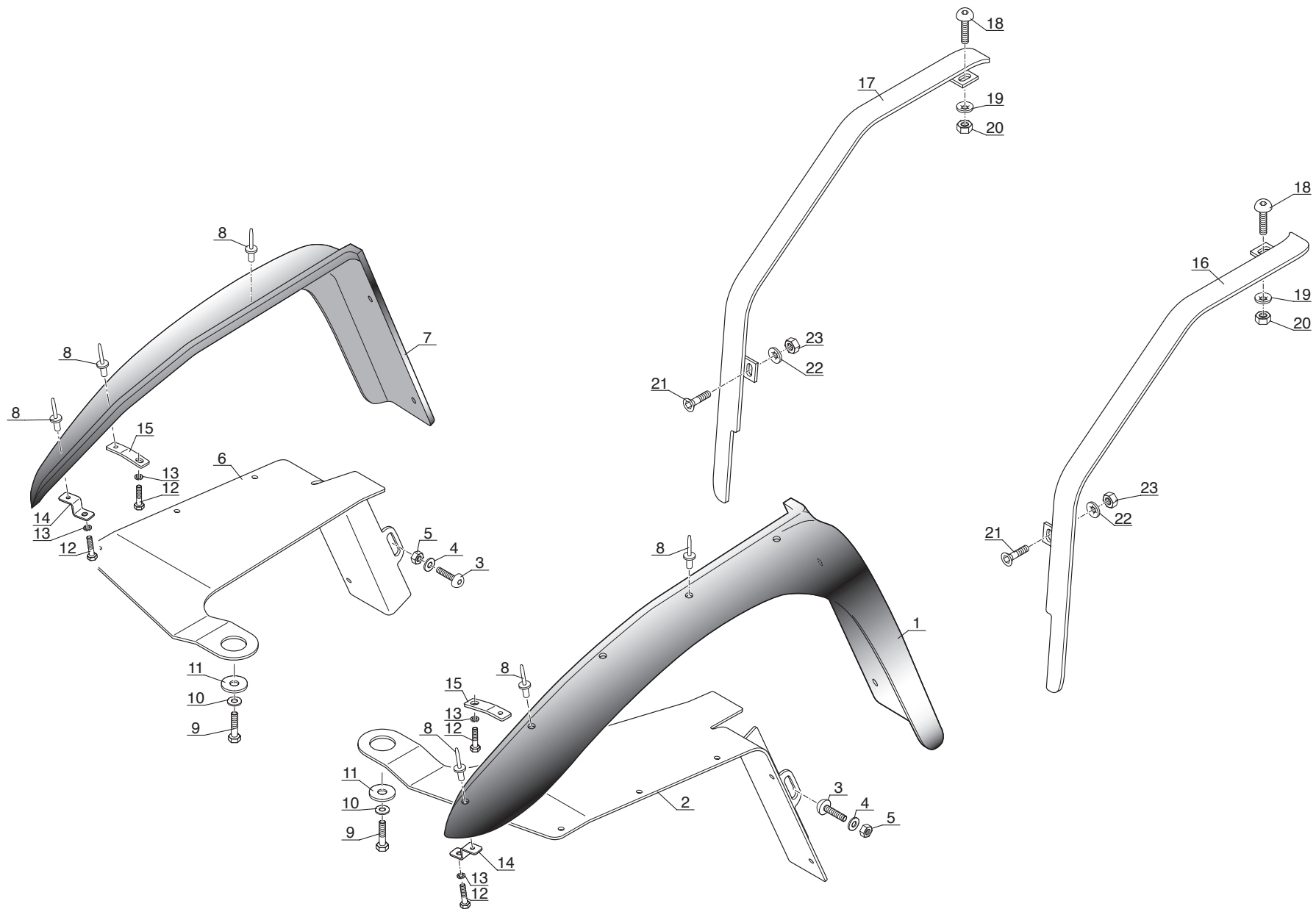



Catalogue : 647000

1	GARDE-BOUE KUHLESPRITZBLECH GUARDABARROS SPLASH APRON PARAFANGO			Qté-Menge-Cant-Qty-Q.ta										8 AA		607		M					
	Rep Hinw Fig Item Rif	Numéro Teil-Nr Numero Part-Nr Part-Nr	Désignation Bezeichnung Descripcion Description Descrizione	1	2	3	4	5	6	7	8	9	10	11	12	13	14		15	16	17	18	19
1	217700	Bavette arrière droit Parrabarros trasero derecho Protezione posteriore destro	- Recht hintersmutzfänger - R.H. rear flap -	1	1																		
2	218503	Support arrière droit Soporte trasero derecho Supporto posteriore destro	- Recht hinter träger - R.H. rear bracket -	1	1																		
3	189172	Vis CBHc,M 6- 16-10.9-ZN5/NOIR- Tornillo Vite	- Schraube - Screw -	2	2																		
4	29469	Rondelle M 6 ZN Arandela Rondella	- Unterlegscheibe - Washer -	2	2																		
5	25714	Ecrou H ,M 6 ZN Tuerca Dado	- Mutter - Nut -	2	2																		
6	218504	Support arrière gauche Soporte trasero izquierdo Supporto posteriore sinistro	- Link hinter träger - L.H. rear bracket -	1	1																		
7	217701	Bavette arrière gauche Parrabarros trasero izquierdo Protezione posteriore sinistro-	- Link hintersmutzfänger - L.H. rear flap -	1	1																		
8	77808	Rivet Ø 4,8 x 18 Remache Rivetto	- Niete - Rivet -	14	14																		
9	54951	Vis H,M 8- 16-8.8-ZN8/C Tornillo Vite	- Schraube - Screw -	2	2																		
10	61674	Rondelle M 8 ZN Arandela Rondella	- Unterlegscheibe - Washer -	2	2																		
11	36010	Rondelle SP 10,5x 45 x 4 ZN Arandela Rondella	- Unterlegscheibe - Washer -	2	2																		

+

Catalogue : 647000

2

GARDE-BOUE  
 KUHLESPRITZBLECH  
 GUARDABARROS  
 SPLASH APRON  
 PARAFANGO

Qté-Menge-Cant-Qty-Q.ta

8 AA

607

M

1-	MH20-4T	BUG. S2-E3	11-
2-	MH25-4T	BUG. S2-E3	12-
3-	MSI 20T	S2-E3	13-
4-	MSI 20T	BUG. S2-E3	14-
5-	MSI 25T	S2-E3	15-
6-	MSI 25T	BUG. S2-E3	16-
7-	MSI 30T	S2-E3	17-
8-	MSI 30T	BUG. S2-E3	18-
9-	MSI 35T	S2-E3	19-
10-	MSI 35T	BUG. S2-E3	20-

Rep Hinw Fig Item Rif	Numéro Teil-Nr Numero Part-Nr Part-Nr	Désignation Bezeichnung Description Descrizione	1	2	3	4	5	6	7	8	9	10	11	12	13	14	15	16	17	18	19	20
12	25713	Vis H,M 6- 16-8.8-ZN5/C Tornillo Vite	-	Schraube - Screw -	4	4																
13	42316	Rondelle W 6 ZN Arandela Rondella	-	Unterlegscheibe - Washer -	4	4																
14	250679	Support Soporte Supporto	-	Träger - Bracket -	2	2																
15	254773	Support Soporte Supporto	-	Träger - Bracket -	2	2																
16	239524	Garde-Boue avant droit Guardabarros delantero derecho- Parafango anteriore destro	-	Recht vorn kühlerepritzblech R.H. front splash apron -	1	1																
17	239522	Garde-Boue avant gauche Guardabarros delantero izquierdo L.H. front splash apron Parafango anteriore sinistro	-	Link vorn kühlerepritzblech -	1	1																
18	201022	Vis CBHc,M10- 30 zinguée Tornillo Vite	-	Schraube - Screw -	2	2																
19	183026	Rondelle JZC10 10,2x26 x1,4CAD.BICH Unterlegscheibe Arandela Rondella	-	Washer -	2	2																
20	56354	Ecrou H ,M10 zingué Tuerca Dado	-	Mutter - Nut -	2	2																
21	168431	Vis FHc,M10- 30-10.9-ZN8/C Tornillo Vite	-	Schraube - Screw -	2	2																
22	183026	Rondelle JZC10 10,2x26 x1,4CAD.BICH Unterlegscheibe Arandela Rondella	-	Washer -	2	2																

+

Catalogue : 647000

3

GARDE-BOUE  
 KUHLESPRITZBLECH  
 GUARDABARROS  
 SPLASH APRON  
 PARAFANGO

Qté-Menge-Cant-Qty-Q.ta

8 AA

607

M

1-	MH20-4T	BUG. S2-E3	11-
2-	MH25-4T	BUG. S2-E3	12-
3-	MSI 20T	S2-E3	13-
4-	MSI 20T	BUG. S2-E3	14-
5-	MSI 25T	S2-E3	15-
6-	MSI 25T	BUG. S2-E3	16-
7-	MSI 30T	S2-E3	17-
8-	MSI 30T	BUG. S2-E3	18-
9-	MSI 35T	S2-E3	19-
10-	MSI 35T	BUG. S2-E3	20-

Rep Hinw Fig Item Rif	Numéro Teil-Nr Numero Part-Nr Part-Nr	Désignation Bezeichnung Descripcion Description Descrizione
23	56354	Ecrou H ,M10 zingué Tuerca Dado - Mutter - Nut -

1	2	3	4	5	6	7	8	9	10	11	12	13	14	15	16	17	18	19	20
2	2																		

8 AB 906

POUR TYPE DE PROTEGE CONDUCTEUR  
FÜR FÜHRER SCHUTZVORRICHTUNG TYPEN  
PARA TIPO DE PROTECTOR CONDUCTOR  
FOR DRIVER' S OVERHEAD GUARD TYPE  
PER TIPO DI COPRICONDUITTORE

□ 264 509

PROTEGE CONDUCTEUR (Détails)  
FÜHRER SCHUTZVORRICHTUNG (Einzelteile)  
PROTECTOR CONDUCTOR (Details)  
DRIVER' S OVERHEAD GUARD (Details)  
PROTEZIONE CONDUCENTE (Dettaglio)

MSI 20 / 25 / 30 / 35 T S2-E3

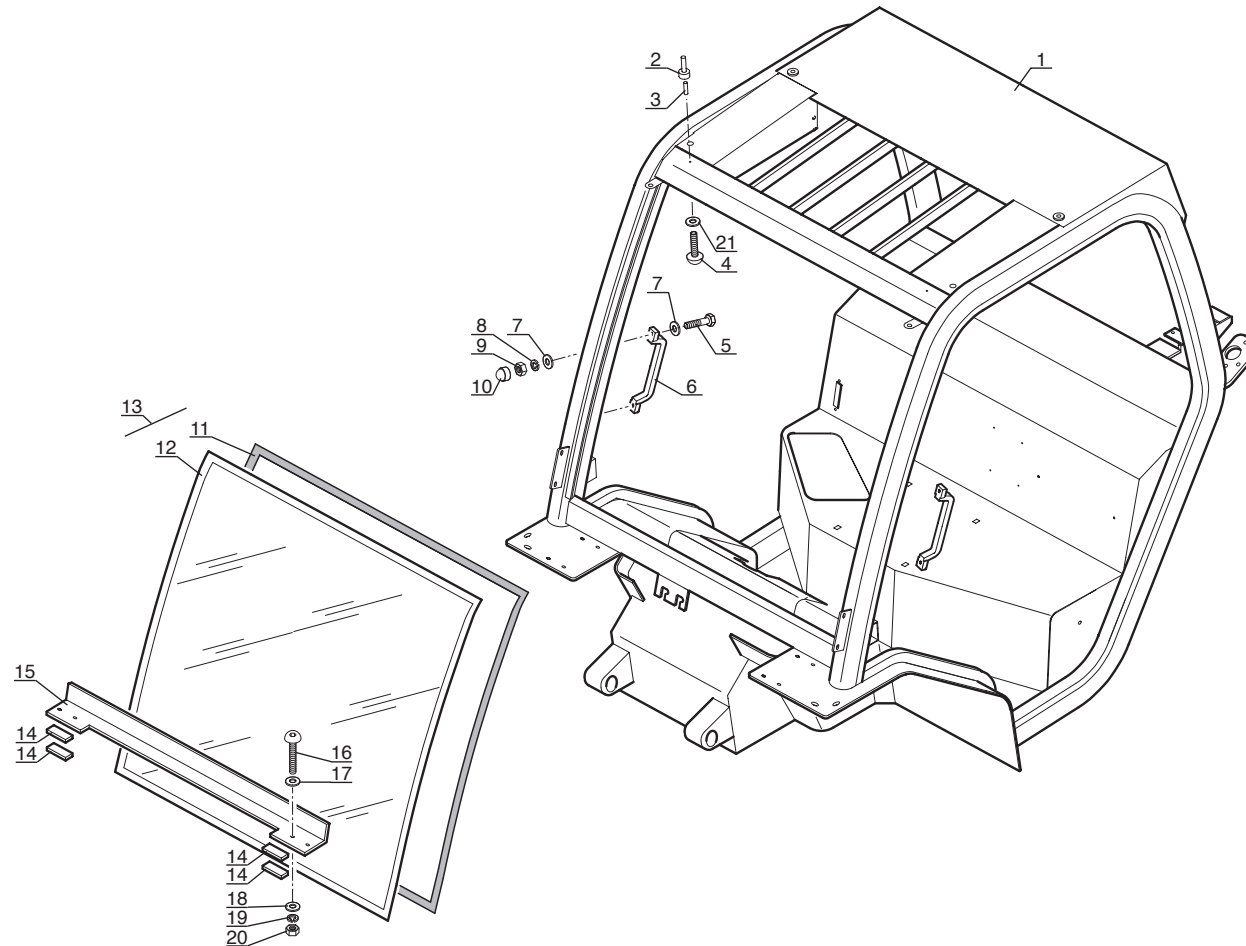

Catalogue : 264509MOD

Qté-Menge-Cant-Qty-Q.ta

8 AB

906

M

1

PROTEGE CONDUCTEUR (Détails)  
 FÄHRER SCHUTZVORRICHTUNG (Einzelteile)  
 PROTECTOR CONDUCTOR (Detalles)  
 DRIVER'S OVERHEAD GUARD (Details)  
 PROTEZIONE CONDUCENTE (Dettaglio)

1-	264509MOD	11-
2-		12-
3-		13-
4-		14-
5-		15-
6-		16-
7-		17-
8-		18-
9-		19-
10-		20-

Rep Hinw Fig Item Rif	Numéro Teil-Nr Numero Part-Nr Part-Nr	Désignation Bezeichnung Descripcion Description Descrizione	Qté-Menge-Cant-Qty-Q.ta																			
			1	2	3	4	5	6	7	8	9	10	11	12	13	14	15	16	17	18	19	20
1	747172	Ossature de protège conducteur Führer schutzvorrichtung rahmenwerk Esqueleto de protector conductor Driver's overhead guard framework Struttura protezione conducente	1																			
2	603305	Butée - Anschlag Tope - Stop Battuta -	2																			
3	603845	Bouchon - Stopfen Tapón - Plug Tappo -	2																			
4	183396	Vis CBHc,M 6- 16-ZN NOIR - Schraube Tornillo - Screw Vite -	2																			
5	46668	Vis H,M 6- 20-8.8-ZN5/C - Schraube Tornillo - Screw Vite -	4																			
6	195535	Poignée - Handgriff Agarrador - Handle Maniglia -	2																			
7	29469	Rondelle M 6 ZN - Unterlegscheibe Arandela - Washer Rondella -	8																			
8	42316	Rondelle W 6 ZN - Unterlegscheibe Arandela - Washer Rondella -	4																			
9	25714	Ecrou H ,M 6 ZN - Mutter Tuerca - Nut Dado -	4																			
10	55404	Capuchon - Kappe Capuchón - Cap Cappuccio -	4																			
11	702995	Joint profilé - Dichtungsstreifen Junta perfilada - Weatherstrip Guarnizione -	1																			

+

Catalogue : 264509MOD

2

PROTEGE CONDUCTEUR (Détails)  
 FÄHRER SCHUTZVORRICHTUNG (Einzelteile)  
 PROTECTOR CONDUCTOR (Detalles)  
 DRIVER'S OVERHEAD GUARD (Details)  
 PROTEZIONE CONDUCENTE (Dettaglio)

Qté-Menge-Cant-Qty-Q.ta

8 AB

906

M

1-	264509MOD	11-
2-		12-
3-		13-
4-		14-
5-		15-
6-		16-
7-		17-
8-		18-
9-		19-
10-		20-

Rep Hinw Fig Item Rif	Numéro Teil-Nr Numero Part-Nr Part-Nr	Désignation Bezeichnung Descripcion Description Descrizione	Qté-Menge-Cant-Qty-Q.ta																			
			1	2	3	4	5	6	7	8	9	10	11	12	13	14	15	16	17	18	19	20
12	203896	Pare brise, nu Parabrisas, solo Vetro, nudo - Windschutzscheibe, allein - Windscreen, stripped -	1																			
13	205164	Pare brise + Joint profilé Windschutzscheibe + Dichtungsstreifen Parabrisas + Junta perfilada - Windscreen + Weatherstrip Vetro + Guarnizióne -	1																			
14	178626	Cale Cala Spessore - Keil - Wedge -	4																			
15	205165	Patte de fixation Brida de fijación Flangia di fissaggio - Befestigung auge - Fastening lug -	1																			
16	202418	Vis CBHC,M 8- 25-ZN NOIRE Tornillo Vite - Schraube - Screw -	4																			
17	194661	Rondelle Arandela Rondella - Unterlegscheibe - Washer -	4																			
18	61674	Rondelle M 8 ZN Arandela Rondella - Unterlegscheibe - Washer -	4																			
19	42325	Rondelle W 8 ZN Arandela Rondella - Unterlegscheibe - Washer -	4																			
20	58528	Ecrou H ,M 8 ZN Tuerca Dado - Mutter - Nut -	4																			
21	194673	Rondelle plastique Arandela plástica Rondella plastica - Plastischeibe - Plastic washer -	2																			
		* MSI 20 T S1-E2 MSI 25 T S1-E2 MSI 30 T S1-E2																				

+

**Catalogue : 264509MOD**

**3**

PROTEGE CONDUCTEUR (Détails)  
 FÄHRER SCHUTZVORRICHTUNG (Einzelteile)  
 PROTECTOR CONDUCTOR (Detalles)  
 DRIVER'S OVERHEAD GUARD (Details)  
 PROTEZIONE CONDUCENTE (Dettaglio)

Qté-Menge-Cant-Qty-Q.ta

**8 AB**

**906**

**M**

1-	264509MOD	11-
2-		12-
3-		13-
4-		14-
5-		15-
6-		16-
7-		17-
8-		18-
9-		19-
10-		20-

Rep Hinw Fig Item Rif	Numéro Teil-Nr Numero Part-Nr Part-Nr	Désignation Bezeichnung Descripcion Description Descrizione
-----------------------------------	---	---

1	2	3	4	5	6	7	8	9	10	11	12	13	14	15	16	17	18	19	20
---	---	---	---	---	---	---	---	---	----	----	----	----	----	----	----	----	----	----	----

		A PARTIR DE LA MACHINE N° 242133 AB DER MASCHINE N° 242133 A PARTIR DE LA MAQUINA N° 242133 FROM MACHINE N° 242133 A PARTIR DA MACCHINA N° 242133
--	--	---

8 AB 907

POUR TYPE DE PROTEGE CONDUCTEUR  
FÜR FÜHRER SCHUTZVORRICHTUNG TYPEN  
PARA TIPO DE PROTECTOR CONDUCTOR  
FOR DRIVER' S OVERHEAD GUARD TYPE  
PER TIPO DI COPRICONDUITTORE

□ 264 509

PROTEGE CONDUCTEUR (Détails)  
FÜHRER SCHUTZVORRICHTUNG (Einzelteile)  
PROTECTOR CONDUCTOR (Detailles)  
DRIVER' S OVERHEAD GUARD (Details)  
PROTEZIONE CONDUCENTE (Dettaglio)

MSI 20 / 25 / 30 / 35 T S2-E3

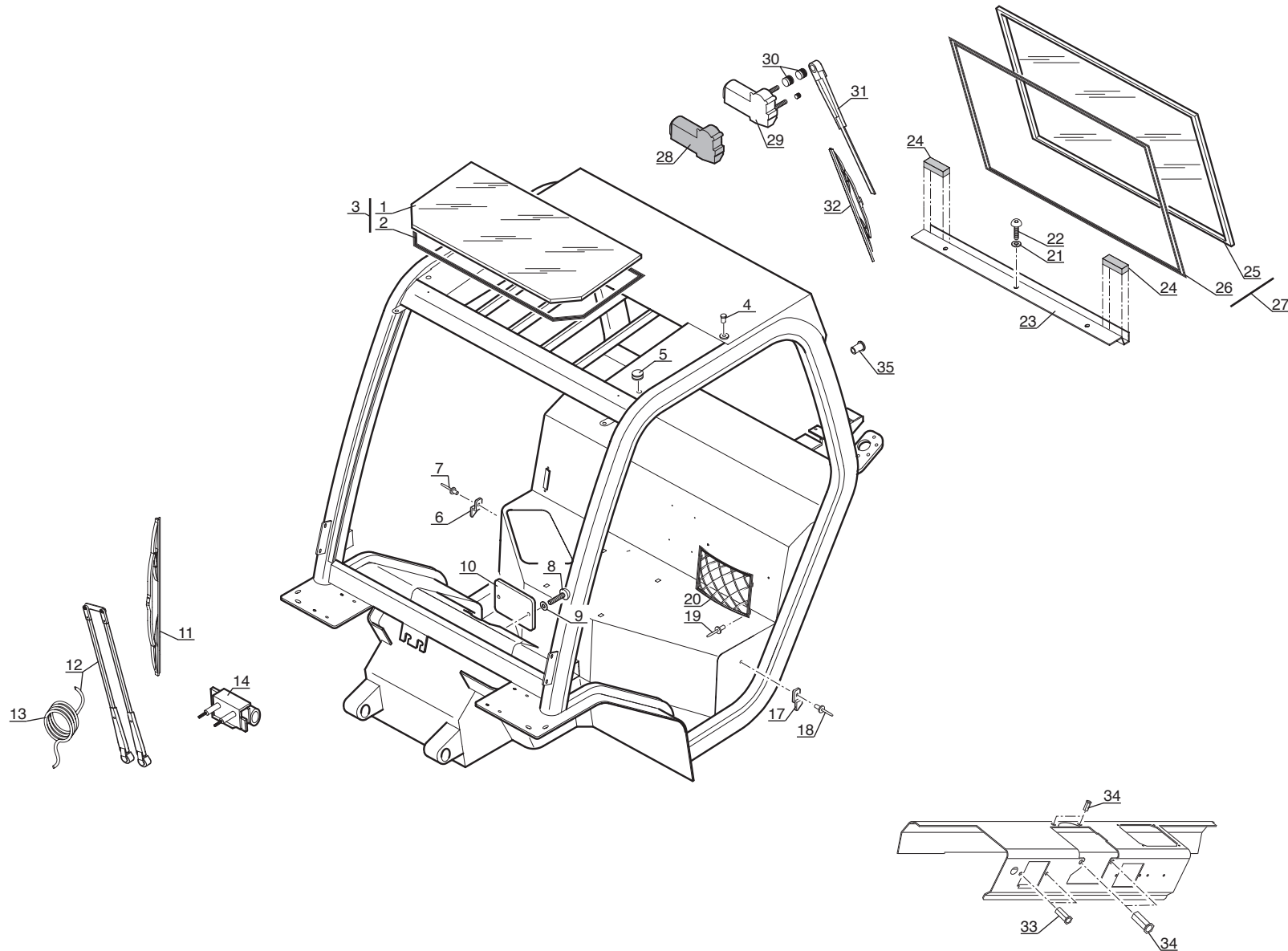



Catalogue : 264509MOD

Qté-Menge-Cant-Qty-Q.ta

8 AB

907

M

1

PROTEGE CONDUCTEUR (Détails)  
 FÄHRER SCHUTZVORRICHTUNG (Einzelteile)  
 PROTECTOR CONDUCTOR (Detalles)  
 DRIVER'S OVERHEAD GUARD (Details)  
 PROTEZIONE CONDUCENTE (Dettaglio)

1-	264509MOD	11-
2-		12-
3-		13-
4-		14-
5-		15-
6-		16-
7-		17-
8-		18-
9-		19-
10-		20-

Rep Hinw Fig Item Rif	Numéro Teil-Nr Numero Part-Nr Part-Nr	Désignation Bezeichnung Descripcion Description Descrizione																				
			1	2	3	4	5	6	7	8	9	10	11	12	13	14	15	16	17	18	19	20
1	206271	Hublot de toit - Dachschild Portillo de techo - Roof viewing port Vetro tettuccio -	1																			
2	182038	Joint mastic - Dichtung Dachscheibe Junta mastique - Seal mastic Giunto mastice -	1																			
3	552426	Hublot de toit + Joint profilé- Dachschild + Dichtung Portillo de techo + Junta perfilada Roof viewing port + Weatherstrip Vetro tettuccio + guarnizione -	1																			
4	562202	Bouchon - Stopfen Tapón - Plug Tappo -	2																			
5	200996	Passe-fil - Gummischeibe Arandela de gaucho - Cable grommet Passo-filo -	7																			
6	561844	Plaque de fixation droite - Recht Befestigung Platte Placa de fijación derecha - R.H. fastening plate Piastra di fissaggio destro -	1																			
7	54568	Rivet - Niete Remache - Rivet Rivetto -	1																			
8	183396	Vis CBHC,M 6- 16-ZN NOIR - Schraube Tornillo - Screw Vite -	2																			
9	194673	Rondelle plastique - Plastischeibe Arandela plástica - Plastic washer Rondella plastica -	2																			
10	561113	Plaque de fermeture - Schlussplatte Placa de cierre - Fastening plate Piastra di chiusura -	1																			
11	198290	Balai d'essuie-glace - Wischerblatt Rasqueta de limpiaparabrisas - Windshield wiper blade Spazzola tergeticristallo -	1																			

+

Catalogue : 264509MOD

2

PROTEGE CONDUCTEUR (Détails)  
 FÄHRER SCHUTZVORRICHTUNG (Einzelteile)  
 PROTECTOR CONDUCTOR (Detalles)  
 DRIVER'S OVERHEAD GUARD (Details)  
 PROTEZIONE CONDUCENTE (Dettaglio)

Qté-Menge-Cant-Qty-Q.ta

8 AB

907

M

1-	264509MOD	11-
2-		12-
3-		13-
4-		14-
5-		15-
6-		16-
7-		17-
8-		18-
9-		19-
10-		20-

Rep Hinw Fig Item Rif	Numéro Teil-Nr Numero Part-Nr Part-Nr	Désignation Bezeichnung Descripcion Description Descrizione	Qté-Menge-Cant-Qty-Q.ta																			
			1	2	3	4	5	6	7	8	9	10	11	12	13	14	15	16	17	18	19	20
12	603606	Porte balai Portaescobilla Supporto spazzola	- Bürstehalter - Blade holder -	1																		
13	205170	Tuyau Tubo Tubo	- Schlauch - Hose -	1																		
14	552672	Moteur d'essuie-glace Motor de limpiaparabrisas Motorino tergeticristallo	- Scheibenwischer motor - Windshield-wiper motor -	1																		
17	561845	Plaque de fixation gauche Placa de fijación izquierda Piastra di fissaggio sinistro	- Link Befestigung Platte - L.H. fastening plate -	1																		
18	54568	Rivet Remache Rivetto	- Niete - Rivet -	1																		
19	54568	Rivet Remache Rivetto	- Niete - Rivet -	4																		
20	561110	Filet Redecilla Filétto	- Netz für dokument - Net -	1																		
21	174132	Rondelle JZC 6 CAD.BICH Arandela Rondella	- Unterlegscheibe - Washer -	3																		
22	183396	Vis CBHC,M 6- 16-ZN NOIR Tornillo Vite	- Schraube - Screw -	3																		
23	205167	Traverse inférieure Traviesa inferior Traversa ponte	- Unter querträger - Lower crossmember -	1																		
24	178626	Cale Cala Spessore	- Keil - Wedge -	2																		

+

Catalogue : 264509MOD

3

PROTEGE CONDUCTEUR (Détails)  
 FÄHRER SCHUTZVORRICHTUNG (Einzelteile)  
 PROTECTOR CONDUCTOR (Detalles)  
 DRIVER'S OVERHEAD GUARD (Details)  
 PROTEZIONE CONDUCENTE (Dettaglio)

Qté-Menge-Cant-Qty-Q.ta

8 AB

907

M

1-	264509MOD	11-
2-		12-
3-		13-
4-		14-
5-		15-
6-		16-
7-		17-
8-		18-
9-		19-
10-		20-

Rep Hinw Fig Item Rif	Numéro Teil-Nr Numero Part-Nr Part-Nr	Désignation Bezeichnung Descripcion Description Descrizione	Qté-Menge-Cant-Qty-Q.ta																			
			1	2	3	4	5	6	7	8	9	10	11	12	13	14	15	16	17	18	19	20
25	203902	Glace arrière, nue Cristal trasero, solo Vetro posteriore, nudo	- Hinter fensterglas, allein - Rear window glass, stripped -	1																		
26	702968	Joint profilé Junta perfilada Guarnizióne	- Dichtungsstreifen - Weatherstrip -	1																		
27	205188	Glace arrière + joint profilé Hinter fensterglas + Dichtungsstreifen Cristal trasero + junta perfilada Rear window glass + weatherstrip Vetro posteriore + guarnizióne-		1																		
28	551568	Cache moteur Funda motor Coperchio motore	- Motor deckplatte - Motor cover -	1																		
29	552760	Moteur d'essuie-glace Motor de limpiaparabrisas Motorino tergicristallo	- Scheibenwischer motor - Windshield-wiper motor -	1																		
30	194579	Bague Anillo Anello	- Büchse - Bushing -	2																		
31	184578	Porte balai Portaescobilla Supporto spazzola	- Bürstehalter - Blade holder -	1																		
32	54557	Balai Escoba Spazzola	- Bürste - Brush -	1																		
33	563829	Insert de 6 Pion Inserto	- Stuck - Insert -	2																		
34	563864	Insert de 8 Pion Inserto	- Stuck - Insert -	4																		
35	702998	Insert Pion Inserto	- Stuck - Insert -	3																		

+

4

**Catalogue : 264509MOD**

PROTEGE CONDUCTEUR (Détails)  
 FÄHRER SCHUTZVORRICHTUNG (Einzelteile)  
 PROTECTOR CONDUCTOR (Detalles)  
 DRIVER'S OVERHEAD GUARD (Details)  
 PROTEZIONE CONDUCENTE (Dettaglio)

Qté-Menge-Cant-Qty-Q.ta

8 AB

907

M

1-	264509MOD	11-
2-		12-
3-		13-
4-		14-
5-		15-
6-		16-
7-		17-
8-		18-
9-		19-
10-		20-

Rep Hinw Fig Item Rif	Numéro Teil-Nr Numero Part-Nr Part-Nr	Désignation Bezeichnung Descripcion Description Descrizione
-----------------------------------	---	---

1	2	3	4	5	6	7	8	9	10	11	12	13	14	15	16	17	18	19	20
---	---	---	---	---	---	---	---	---	----	----	----	----	----	----	----	----	----	----	----

		* MSI 20 T S1-E2 MSI 25 T S1-E2 MSI 30 T S1-E2  A PARTIR DE LA MACHINE N° 242133 AB DER MASCHINE N° 242133 A PARTIR DE LA MAQUINA N° 242133 FROM MACHINE N° 242133 A PARTIR DA MACCHINA N° 242133
--	--	---



8 AB 908

POUR TYPE DE PROTEGE CONDUCTEUR  
FÜR FÜHRER SCHUTZVORRICHTUNG TYPEN  
PARA TIPO DE PROTECTOR CONDUCTOR  
FOR DRIVER' S OVERHEAD GUARD TYPE  
PER TIPO DI COPRICONDUITTORE

□ □ 264 509

PROTEGE CONDUCTEUR (Détails)  
FÜHRER SCHUTZVORRICHTUNG (Einzelteile)  
PROTECTOR CONDUCTOR (Detalles)  
DRIVER' S OVERHEAD GUARD (Details)  
PROTEZIONE CONDUCENTE (Dettaglio)

MSI 20 / 25 / 30 / 35 T S2-E3

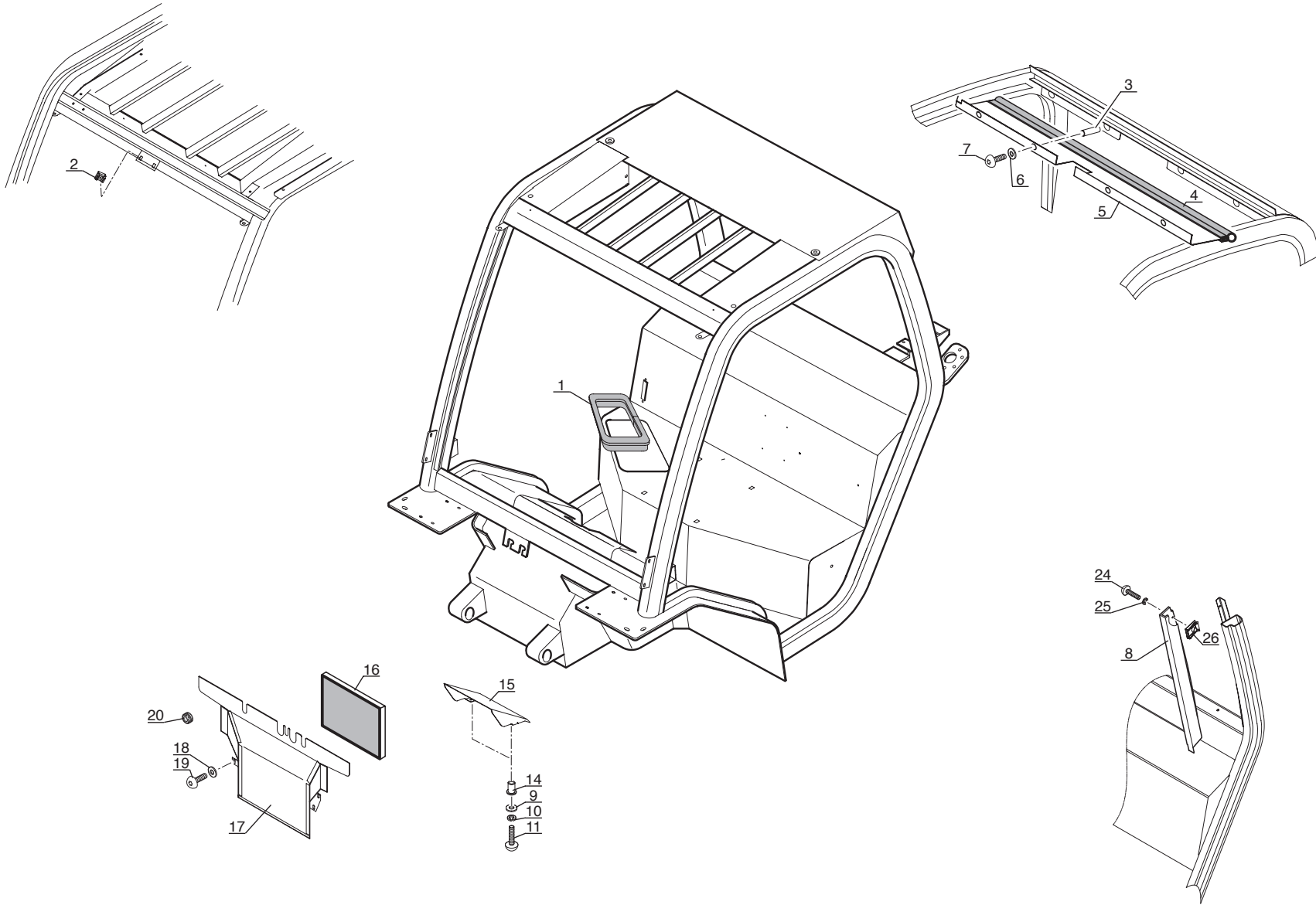

**Catalogue : 264509MOD**

Qté-Menge-Cant-Qty-Q.ta

**8 AB**

**908**

**M**

1

PROTEGE CONDUCTEUR (Détails)  
 FÄHRER SCHUTZVORRICHTUNG (Einzelteile)  
 PROTECTOR CONDUCTOR (Detalles)  
 DRIVER'S OVERHEAD GUARD (Details)  
 PROTEZIONE CONDUCENTE (Dettaglio)

1- 264509MOD 11-  
 2- 12-  
 3- 13-  
 4- 14-  
 5- 15-  
 6- 16-  
 7- 17-  
 8- 18-  
 9- 19-  
 10- 20-

Rep Hinw Fig Item Rif	Numéro Teil-Nr Numero Part-Nr Part-Nr	Désignation Bezeichnung Descripcion Description Descrizione	Qté-Menge-Cant-Qty-Q.ta																			
			1	2	3	4	5	6	7	8	9	10	11	12	13	14	15	16	17	18	19	20
1	603612	Joint profilé Junta perfilada Guarnizióne	- Dichtungsstreifen - Weatherstrip -	1																		
2	603300	Insert Pion Inserto	- Stuck - Insert -	2																		
3	563829	Insert de 6 Pion Inserto	- Stuck - Insert -	4																		
4	72468	Joint d'étanchéité Junta de estanqueidad Guarnizióne	- Dichtungsring - Seal -	1																		
5	747173	Habillage de toit Guarnición de techo Rivestimento tetto	- Dach futter - Roof fittings -	1																		
6	194673	Rondelle plastique Arandela plástica Rondella plastica	- Plastischeibe - Plastic washer -	4																		
7	183396	Vis CBHc,M 6- 16-ZN NOIR Tornillo Vite	- Schraube - Screw -	4																		
8	561142	Habillage arrière gauche Guarnición trasera izquierda Rivestimento posteriore sinistro	- Link hinter futter - L.H. rear fittings -	1																		
9	29469	Rondelle M 6 ZN Arandela Rondella	- Unterlegscheibe - Washer -	2																		
10	42316	Rondelle W 6 ZN Arandela Rondella	- Unterlegscheibe - Washer -	2																		
11	190807	Vis CBHc,M 6- 30-10.9-ZN5/NOIR Tornillo Vite	- Schraube - Screw -	2																		

+

Catalogue : 264509MOD

2

PROTEGE CONDUCTEUR (Détails)  
 FÄHRER SCHUTZVORRICHTUNG (Einzelteile)  
 PROTECTOR CONDUCTOR (Detalles)  
 DRIVER'S OVERHEAD GUARD (Details)  
 PROTEZIONE CONDUCENTE (Dettaglio)

Qté-Menge-Cant-Qty-Q.ta

8 AB

908

M

1-	264509MOD	11-
2-		12-
3-		13-
4-		14-
5-		15-
6-		16-
7-		17-
8-		18-
9-		19-
10-		20-

Rep Hinw Fig Item Rif	Numéro Teil-Nr Numero Part-Nr Part-Nr	Désignation Bezeichnung Descripcion Description Descrizione	Qté-Menge-Cant-Qty-Q.ta																			
			1	2	3	4	5	6	7	8	9	10	11	12	13	14	15	16	17	18	19	20
14	563858	Insert Pion Inserto - Stuck - Insert -	2																			
15	205035	Plaque de fermeture avant Placa de cierre delantera Piastra di chiusura anteriore - Vorn schlussplatte - Front fastening plate -	1																			
16	747174	Garniture Guarnición Guarnizione - Packung - Packing -	1																			
17	747175	Plaque de fermeture avant Placa de cierre delantera Piastra di chiusura anteriore - Vorn schlussplatte - Front fastening plate -	1																			
18	174132	Rondelle JZC 6 CAD.BICH Arandela Rondella - Unterlegscheibe - Washer -	3																			
19	183396	Vis CBHc,M 6- 16-ZN NOIR Tornillo Vite - Schraube - Screw -	3																			
20	193158	Passe-fil Arandela de gaucho Passo-filo - Gummischeibe - Cable grommet -	1																			
24	184036	Vis CBHc,M 5- 16-10.9-ZN5/NOIR Tornillo Vite - Schraube - Screw -	1																			
25	564594	Rondelle Arandela Rondella - Unterlegscheibe - Washer -	1																			
26	551582	Ecrou Tuerca Dado - Mutter - Nut -	1																			
		* MSI 20 T S1-E2 MSI 25 T S1-E2 MSI 30 T S1-E2  A PARTIR DE LA MACHINE N° 242133																				

+



**Catalogue : 264509MOD**

**3**

PROTEGE CONDUCTEUR (Détails)  
 FÄHRER SCHUTZVORRICHTUNG (Einzelteile)  
 PROTECTOR CONDUCTOR (Detalles)  
 DRIVER'S OVERHEAD GUARD (Details)  
 PROTEZIONE CONDUCENTE (Dettaglio)

Qté-Menge-Cant-Qty-Q.ta

**8 AB**

**908**

**M**

1-	264509MOD	11-
2-		12-
3-		13-
4-		14-
5-		15-
6-		16-
7-		17-
8-		18-
9-		19-
10-		20-

Rep Hinw Fig Item Rif	Numéro Teil-Nr Numero Part-Nr Part-Nr	Désignation Bezeichnung Descripcion Description Descrizione
-----------------------------------	---	---

1	2	3	4	5	6	7	8	9	10	11	12	13	14	15	16	17	18	19	20
---	---	---	---	---	---	---	---	---	----	----	----	----	----	----	----	----	----	----	----

		AB DER MASCHINE N° 242133 A PARTIR DE LA MAQUINA N° 242133 FROM MACHINE N° 242133 A PARTIR DA MACCHINA N° 242133
--	--	---

8 AB 909

POUR TYPE DE PROTEGE CONDUCTEUR  
FÜR FÜHRER SCHUTZVORRICHTUNG TYPEN  
PARA TIPO DE PROTECTOR CONDUCTOR  
FOR DRIVER' S OVERHEAD GUARD TYPE  
PER TIPO DI COPRICONDUITTORE

□ 264 509

PROTEGE CONDUCTEUR (Détails)  
FÜHRER SCHUTZVORRICHTUNG (Einzelteile)  
PROTECTOR CONDUCTOR (Detailles)  
DRIVER' S OVERHEAD GUARD (Detalles)  
PROTEZIONE CONDUCENTE (Dettaglio)

MSI 20 / 25 / 30 / 35 T S2-E3

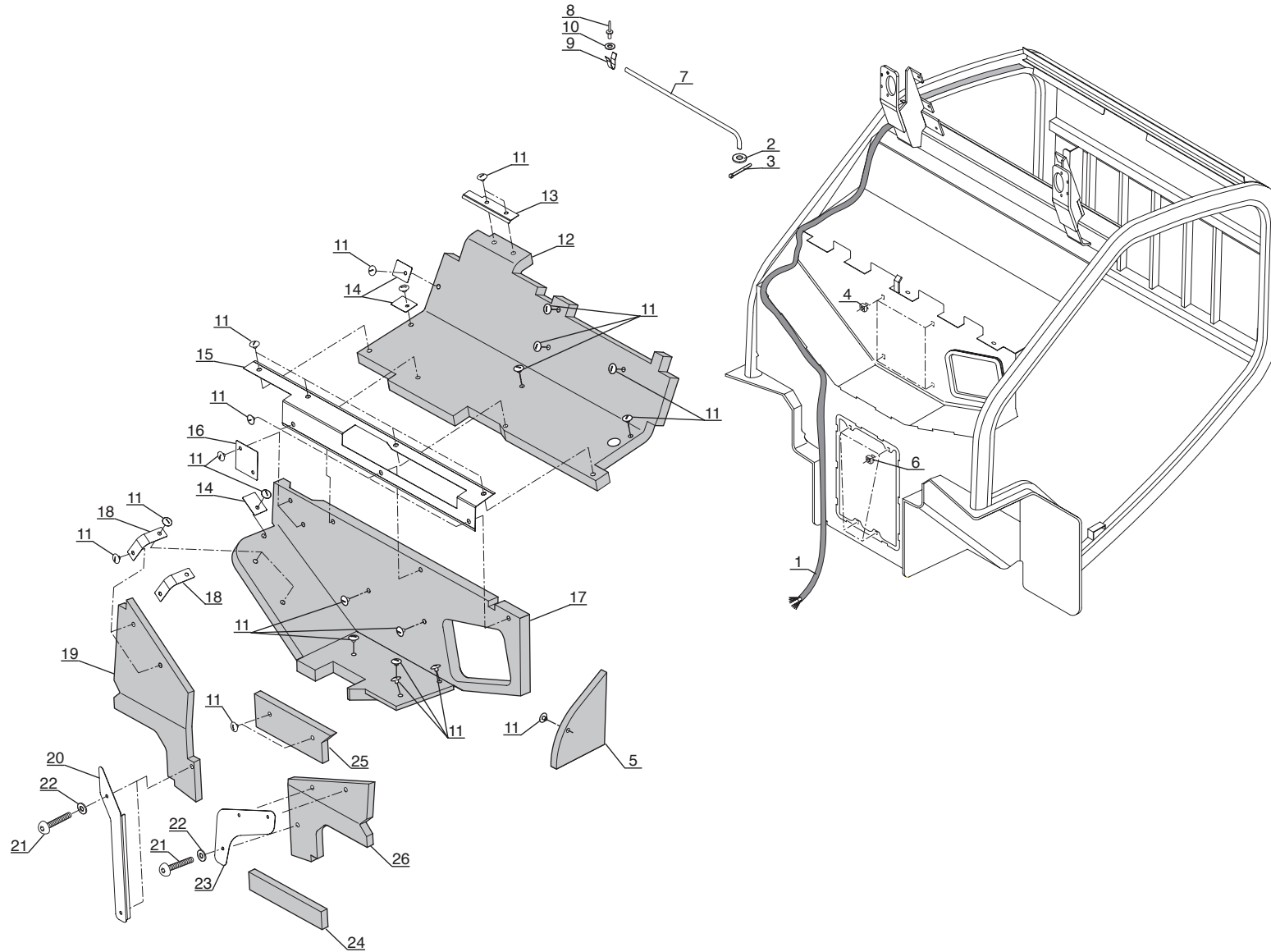

Catalogue : 264509MOD

Qté-Menge-Cant-Qty-Q.ta

8 AB

909

M

1

PROTEGE-CONDUCTEUR (Détails)  
 FÄHRER SCHUTZVORRICHTUNG (Einzelteile)  
 PROTECTOR CONDUCTOR (Detalles)  
 DRIVER'S OVERHEAD GUARD (Details)  
 PROTEZIONE CONDUCENTE (Dettaglio)

1- 264509MOD 11-  
 2- 12-  
 3- 13-  
 4- 14-  
 5- 15-  
 6- 16-  
 7- 17-  
 8- 18-  
 9- 19-  
 10- 20-

Rep Hinw Fig Item Rif	Numéro Teil-Nr Numero Part-Nr Part-Nr	Désignation Bezeichnung Descripcion Description Descrizione	Qté-Menge-Cant-Qty-Q.ta																			
			1	2	3	4	5	6	7	8	9	10	11	12	13	14	15	16	17	18	19	20
1	561117	Faisceau principal Haz principal Fascio principale	- Haupt Kabelbaum - Main wiring harness -	1																		
2	561140	Rondelle Arandela Rondella	- Unterlegscheibe - Washer -	1																		
3	561139	Goupille Pasador Spina	- Stift - Pin -	1																		
4	205052	Ecrou Tuerca Dado	- Mutter - Nut -	4																		
5	747176	Insonorisant Insonorizador Ammortizzatore	- Schalldämpfungmoos - Sound proofing foam -	1																		
6	205057	Ecrou Tuerca Dado	- Mutter - Nut -	4																		
7	561137	Béquille de maintien Apoyo Cavalletto di sostegno	- Tragstange - Shore -	1																		
8	54568	Rivet Remache Rivetto	- Niete - Rivet -	1																		
9	561138	Clip Clip Fermaglio	- Klammer - Clip -	1																		
10	28988	Rondelle M 4 ZN Arandela Rondella	- Unterlegscheibe - Washer -	1																		
11	603846	Clip Clip Fermaglio	- Klammer - Clip -	32																		

+



**Catalogue : 264509MOD**

3

PROTEGE-CONDUCTEUR (Détails)  
 FÄHRER SCHUTZVORRICHTUNG (Einzelteile)  
 PROTECTOR CONDUCTOR (Detalles)  
 DRIVER'S OVERHEAD GUARD (Details)  
 PROTEZIONE CONDUCENTE (Dettaglio)

Qté-Menge-Cant-Qty-Q.ta

8 AB

909

M

1-	264509MOD	11-
2-		12-
3-		13-
4-		14-
5-		15-
6-		16-
7-		17-
8-		18-
9-		19-
10-		20-

Rep Hinw Fig Item Rif	Numéro Teil-Nr Numero Part-Nr Part-Nr	Désignation Bezeichnung Descripcion Description Descrizione	Qté-Menge-Cant-Qty-Q.ta																			
			1	2	3	4	5	6	7	8	9	10	11	12	13	14	15	16	17	18	19	20
23	564607	Support Soporte Supporto - Träger - Bracket -	1																			
24	561124	Insonorisant Insonorizador Ammortizzatore - Schalldämpfungmoos - Sound proofing foam -	1																			
25	747185	Insonorisant Insonorizador Ammortizzatore - Schalldämpfungmoos - Sound proofing foam -	1																			
26	747186	Insonorisant droit Insonorizador derecho Ammortizzatore destro - Recht shalldämpfungmoos - R.H. sound proofing foam -  * MSI 20 T S1-E2 MSI 25 T S1-E2 MSI 30 T S1-E2  A PARTIR DE LA MACHINE N° 242133 AB DER MASCHINE N° 242133 A PARTIR DE LA MAQUINA N° 242133 FROM MACHINE N° 242133 A PARTIR DA MACCHINA N° 242133	1																			

8 AB 910

POUR TYPE DE PROTEGE CONDUCTEUR  
FÜR FÜHRER SCHUTZVORRICHTUNG TYPEN  
PARA TIPO DE PROTECTOR CONDUCTOR  
FOR DRIVER' S OVERHEAD GUARD TYPE  
PER TIPO DI COPRICONDUITTORE

□ 264 511

PROTEGE CONDUCTEUR (Détails)  
FÜHRER SCHUTZVORRICHTUNG (Einzelteile)  
PROTECTOR CONDUCTOR (Details)  
DRIVER' S OVERHEAD GUARD (Details)  
PROTEZIONE CONDUCENTE (Dettaglio)

MH 20-4 T BUGGIE S2-E3  
MH 25-4 T BUGGIE S2-E3  
MSI 20 / 25 / 30 / 35 T BUGGIE S2-E3

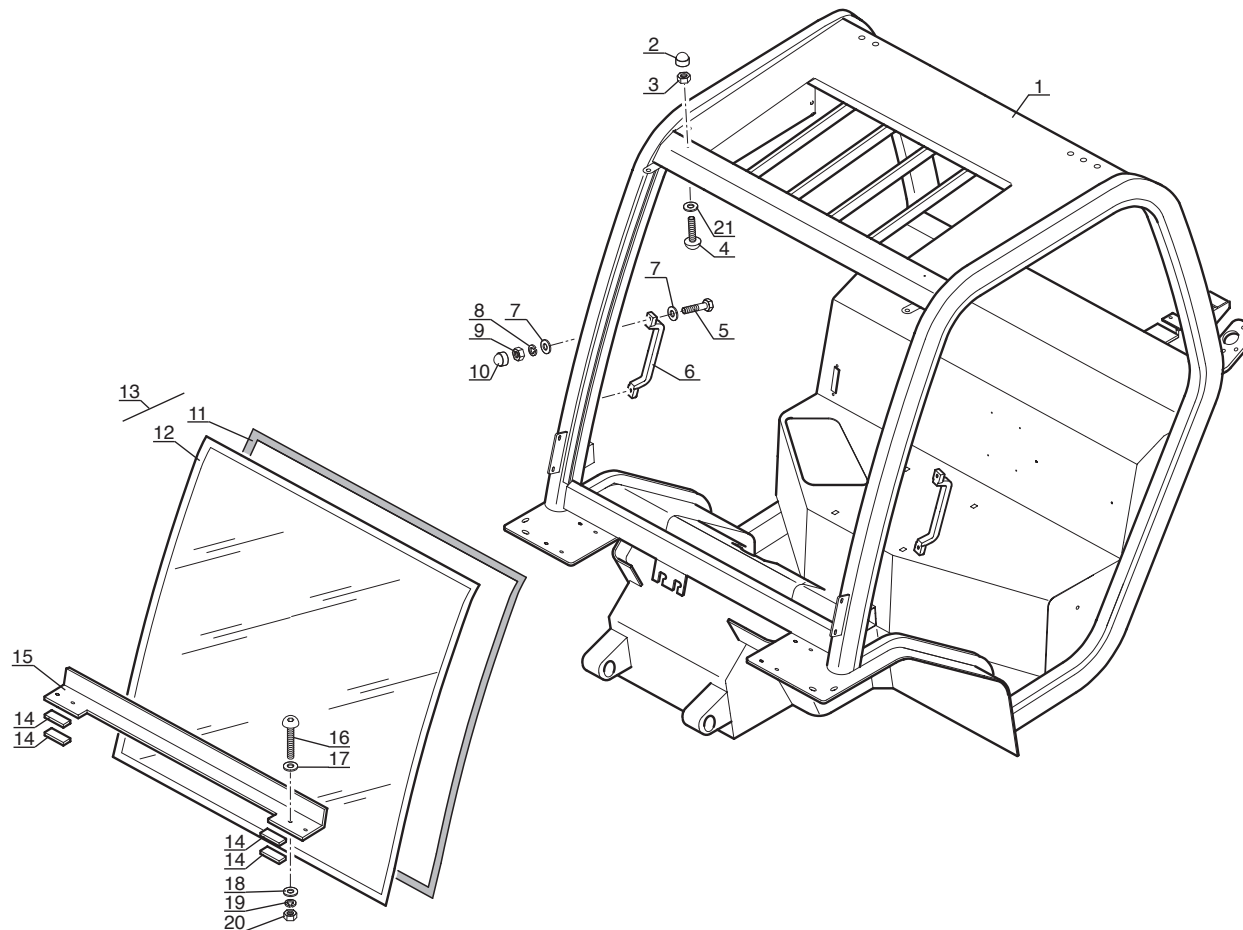

**Catalogue : 264511MOD**

Qté-Menge-Cant-Qty-Q.ta

**8 AB**

**910**

**M**

1

PROTEGE CONDUCTEUR (Détails)  
 FÄHRER SCHUTZVORRICHTUNG (Einzelteile)  
 PROTECTOR CONDUCTOR (Detalles)  
 DRIVER'S OVERHEAD GUARD (Details)  
 PROTEZIONE CONDUCENTE (Dettaglio)

1- 264511MOD 11-  
 2- 12-  
 3- 13-  
 4- 14-  
 5- 15-  
 6- 16-  
 7- 17-  
 8- 18-  
 9- 19-  
 10- 20-

Rep Hinw Fig Item Rif	Numéro Teil-Nr Numero Part-Nr Part-Nr	Désignation Bezeichnung Descripcion Description Descrizione	Qté-Menge-Cant-Qty-Q.ta																			
			1	2	3	4	5	6	7	8	9	10	11	12	13	14	15	16	17	18	19	20
1	747283	Ossature de protège conducteur Führer schutzvorrichtung rahmenwerk Esqueleto de protector conductor Driver's overhead guard framework Struttura protezione conducente	1																			
2	55404	Capuchon - Kappe Capuchón - Cap Cappuccio -	2																			
3	25714	Ecrou H ,M 6 ZN - Mutter Tuerca - Nut Dado -	2																			
4	183396	Vis CBHc,M 6- 16-ZN NOIR - Schraube Tornillo - Screw Vite -	2																			
5	46668	Vis H,M 6- 20-8.8-ZN5/C - Schraube Tornillo - Screw Vite -	4																			
6	195535	Poignée - Handgriff Agarrador - Handle Maniglia -	2																			
7	29469	Rondelle M 6 ZN - Unterlegscheibe Arandela - Washer Rondella -	8																			
8	42316	Rondelle W 6 ZN - Unterlegscheibe Arandela - Washer Rondella -	4																			
9	25714	Ecrou H ,M 6 ZN - Mutter Tuerca - Nut Dado -	4																			
10	55404	Capuchon - Kappe Capuchón - Cap Cappuccio -	4																			
11	702995	Joint profilé - Dichtungsstreifen Junta perfilada - Weatherstrip Guarnizione -	1																			

+

Catalogue : 264511MOD

2

PROTEGE CONDUCTEUR (Détails)  
 FÄHRER SCHUTZVORRICHTUNG (Einzelteile)  
 PROTECTOR CONDUCTOR (Detalles)  
 DRIVER'S OVERHEAD GUARD (Details)  
 PROTEZIONE CONDUCENTE (Dettaglio)

Qté-Menge-Cant-Qty-Q.ta

8 AB

910

M

1-	264511MOD	11-
2-		12-
3-		13-
4-		14-
5-		15-
6-		16-
7-		17-
8-		18-
9-		19-
10-		20-

Rep Hinw Fig Item Rif	Numéro Teil-Nr Numero Part-Nr Part-Nr	Désignation Bezeichnung Descripcion Description Descrizione	Qté-Menge-Cant-Qty-Q.ta																			
			1	2	3	4	5	6	7	8	9	10	11	12	13	14	15	16	17	18	19	20
12	550869	Pare brise, nu Parabrisas, solo Vetro, nudo - Windschutzscheibe, allein - Windscreen, stripped -	1																			
13	550868	Pare brise + Joint profilé Windschutzscheibe + Dichtungsstreifen Parabrisas + Junta perfilada - Windscreen + Weatherstrip Vetro + Guarnizióne -	1																			
14	178626	Cale Cala Spessore - Keil - Wedge -	4																			
15	205165	Patte de fixation Brida de fijación Flangia di fissaggio - Befestigung auge - Fastening lug -	1																			
16	202418	Vis CBHC,M 8- 25-ZN NOIRE Tornillo Vite - Schraube - Screw -	4																			
17	194661	Rondelle Arandela Rondella - Unterlegscheibe - Washer -	4																			
18	61674	Rondelle M 8 ZN Arandela Rondella - Unterlegscheibe - Washer -	4																			
19	42325	Rondelle W 8 ZN Arandela Rondella - Unterlegscheibe - Washer -	4																			
20	58528	Ecrou H ,M 8 ZN Tuerca Dado - Mutter - Nut -	4																			
21	194673	Rondelle plastique Arandela plástica Rondella plastica - Plastischeibe - Plastic washer -	2																			
		* MSI 20 T BUGGIE S1-E2 MSI 25 T BUGGIE S1-E2 MSI 30 T BUGGIE S1-E2																				

+



**Catalogue : 264511MOD**

**3**

PROTEGE CONDUCTEUR (Détails)  
 FÄHRER SCHUTZVORRICHTUNG (Einzelteile)  
 PROTECTOR CONDUCTOR (Detalles)  
 DRIVER'S OVERHEAD GUARD (Details)  
 PROTEZIONE CONDUCENTE (Dettaglio)

Qté-Menge-Cant-Qty-Q.ta

**8 AB**

**910**

**M**

1-	264511MOD	11-
2-		12-
3-		13-
4-		14-
5-		15-
6-		16-
7-		17-
8-		18-
9-		19-
10-		20-

Rep Hinw Fig Item Rif	Numéro Teil-Nr Numero Part-Nr Part-Nr	Désignation Bezeichnung Descripcion Description Descrizione
-----------------------------------	---	---

1	2	3	4	5	6	7	8	9	10	11	12	13	14	15	16	17	18	19	20
---	---	---	---	---	---	---	---	---	----	----	----	----	----	----	----	----	----	----	----

		A PARTIR DE LA MACHINE N° 242133 AB DER MASCHINE N° 242133 A PARTIR DE LA MAQUINA N° 242133 FROM MACHINE N° 242133 A PARTIR DA MACCHINA N° 242133
--	--	---

8 AB 911

POUR TYPE DE PROTEGE CONDUCTEUR  
FÜR FÜHRER SCHUTZVORRICHTUNG TYPEN  
PARA TIPO DE PROTECTOR CONDUCTOR  
FOR DRIVER' S OVERHEAD GUARD TYPE  
PER TIPO DI COPRICONDUITTORE

□ 264 511

PROTEGE CONDUCTEUR (Détails)  
FÜHRER SCHUTZVORRICHTUNG (Einzelteile)  
PROTECTOR CONDUCTOR (Detailles)  
DRIVER' S OVERHEAD GUARD (Details)  
PROTEZIONE CONDUCENTE (Dettaglio)

MH 20-4 T BUGGIE S2-E3  
MH 25-4 T BUGGIE S2-E3  
MSI 20 / 25 / 30 / 35 T BUGGIE S2-E3

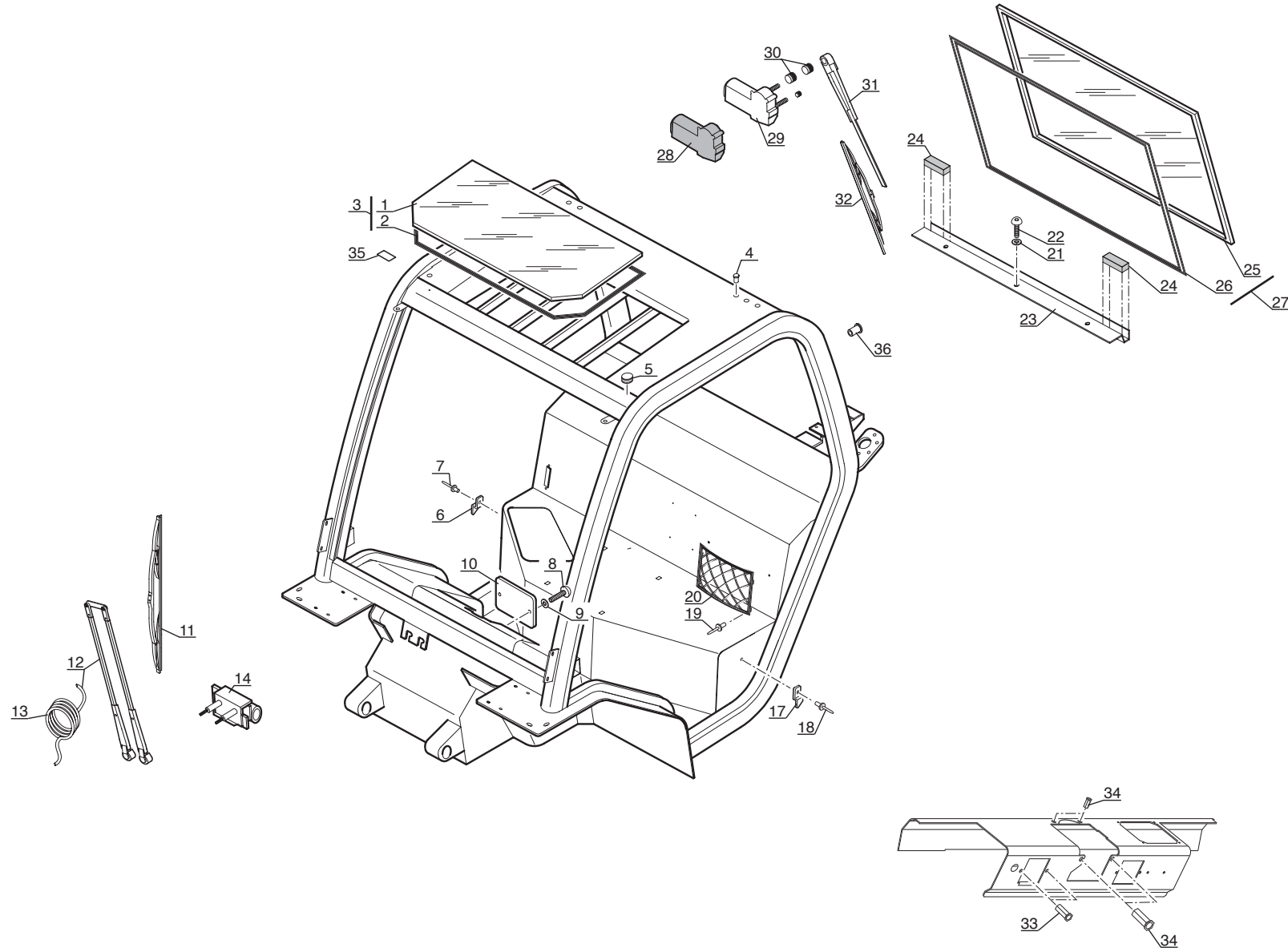

Catalogue : 264511MOD

Qté-Menge-Cant-Qty-Q.ta | 8 AB 911 M

1	PROTEGE CONDUCTEUR (Détails) FÄHRER SCHUTZVORRICHTUNG (Einzelteile) PROTECTOR CONDUCTOR (Detalles) DRIVER'S OVERHEAD GUARD (Details) PROTEZIONE CONDUCENTE (Dettaglio)			1- 264511MOD 11- 2- 12- 3- 13- 4- 14- 5- 15- 6- 16- 7- 17- 8- 18- 9- 19- 10- 20-																			
	Rep Hinw Fig Item Rif	Numéro Teil-Nr Numero Part-Nr Part-Nr	Désignation Bezeichnung Descripcion Description Descrizione	1	2	3	4	5	6	7	8	9	10	11	12	13	14	15	16	17	18	19	20
1	206271	Hublot de toit Portillo de techo Vetro tettuccio	- Dachschild - Roof viewing port -	1																			
2	182038	Joint mastic Junta mastique Giunto mastice	- Dichtung Dachscheibe - Seal mastic -	1																			
3	552426	Hublot de toit + Joint profilé- Portillo de techo + Junta perfilada Roof viewing port + Weatherstrip Vetro tettuccio + guarnizione -	- Dachschild.+ Dichtung -	1																			
4	562202	Bouchon Tapón Tappo	- Stopfen - Plug -	4																			
5	561236	Bouchon Tapón Tappo	- Stopfen - Plug -	7																			
6	561844	Plaque de fixation droite Placa de fijación derecha Piastra di fissaggio destro	- Recht Befestigung Platte - R.H. fastening plate -	1																			
7	54568	Rivet Remache Rivetto	- Niete - Rivet -	1																			
8	183396	Vis CBHC,M 6- 16-ZN NOIR Tornillo Vite	- Schraube - Screw -	2																			
9	194673	Rondelle plastique Arandela plástica Rondella plastica	- Plastischeibe - Plastic washer -	2																			
10	561113	Plaque de fermeture Placa de cierre Piastra di chiusura	- Schlussplatte - Fastening plate -	1																			
11	551874	Balai d'essuie-glace Rasqueta de limpiaparabrisas Spazzola tergeticristallo	- Scheibenwischer bürste - Windshield wiper blade -	1																			

+

Catalogue : 264511MOD

2

PROTEGE CONDUCTEUR (Détails)  
 FÄHRER SCHUTZVORRICHTUNG (Einzelteile)  
 PROTECTOR CONDUCTOR (Detalles)  
 DRIVER'S OVERHEAD GUARD (Details)  
 PROTEZIONE CONDUCENTE (Dettaglio)

Qté-Menge-Cant-Qty-Q.ta

8 AB

911

M

1-	264511MOD	11-
2-		12-
3-		13-
4-		14-
5-		15-
6-		16-
7-		17-
8-		18-
9-		19-
10-		20-

Rep Hinw Fig Item Rif	Numéro Teil-Nr Numero Part-Nr Part-Nr	Désignation Bezeichnung Descripcion Description Descrizione	Qté-Menge-Cant-Qty-Q.ta																			
			1	2	3	4	5	6	7	8	9	10	11	12	13	14	15	16	17	18	19	20
12	193156	Porte balai Portaescobilla Porta spazzola	- Bürstehalter - Blade holder -	1																		
13	205170	Tuyau Tubo Tubo	- Schlauch - Hose -	1																		
14	552672	Moteur d'essuie-glace Motor de limpiaparabrisas Motorino tergeticristallo	- Scheibenwischer motor - Windshield-wiper motor -	1																		
17	561845	Plaque de fixation gauche Placa de fijación izquierda Piastra di fissaggio sinistro	- Link Befestigung Platte - L.H. fastening plate -	1																		
18	54568	Rivet Remache Rivetto	- Niete - Rivet -	1																		
19	54568	Rivet Remache Rivetto	- Niete - Rivet -	4																		
20	561110	Filet Redecilla Filétto	- Netz für dokument - Net -	1																		
21	174132	Rondelle JZC 6 CAD.BICH Arandela Rondella	- Unterlegscheibe - Washer -	3																		
22	183396	Vis CBHC,M 6- 16-ZN NOIR Tornillo Vite	- Schraube - Screw -	3																		
23	205167	Traverse inférieure Traviesa inferior Traversa ponte	- Unter querträger - Lower crossmember -	1																		
24	178626	Cale Cala Spessore	- Keil - Wedge -	2																		

+



**Catalogue : 264511MOD**

4

PROTEGE CONDUCTEUR (Détails)  
 FÄHRER SCHUTZVORRICHTUNG (Einzelteile)  
 PROTECTOR CONDUCTOR (Detalles)  
 DRIVER'S OVERHEAD GUARD (Details)  
 PROTEZIONE CONDUCENTE (Dettaglio)

Qté-Menge-Cant-Qty-Q.ta

8 AB

911

M

1-	264511MOD	11-
2-		12-
3-		13-
4-		14-
5-		15-
6-		16-
7-		17-
8-		18-
9-		19-
10-		20-

Rep Hinw Fig Item Rif	Numéro Teil-Nr Numero Part-Nr Part-Nr	Désignation Bezeichnung Descripcion Description Descrizione
-----------------------------------	---	---

1	2	3	4	5	6	7	8	9	10	11	12	13	14	15	16	17	18	19	20
---	---	---	---	---	---	---	---	---	----	----	----	----	----	----	----	----	----	----	----

36	702998	Insert - Stuck Pion - Insert Inserto -  * MSI 20 T BUGGIE S1-E2 MSI 25 T BUGGIE S1-E2 MSI 30 T BUGGIE S1-E2  A PARTIR DE LA MACHINE N° 242133 AB DER MASCHINE N° 242133 A PARTIR DE LA MAQUINA N° 242133 FROM MACHINE N° 242133 A PARTIR DA MACCHINA N° 242133
----	--------	--

3																				
---	--	--	--	--	--	--	--	--	--	--	--	--	--	--	--	--	--	--	--	--



8 AB 912

POUR TYPE DE PROTEGE CONDUCTEUR  
FÜR FÜHRER SCHUTZVORRICHTUNG TYPEN  
PARA TIPO DE PROTECTOR CONDUCTOR  
FOR DRIVER' S OVERHEAD GUARD TYPE  
PER TIPO DI COPRICONDUITTORE

□ 264 511

PROTEGE CONDUCTEUR (Détails)  
FÜHRER SCHUTZVORRICHTUNG (Einzelteile)  
PROTECTOR CONDUCTOR (Detalles)  
DRIVER' S OVERHEAD GUARD (Details)  
PROTEZIONE CONDUCENTE (Dettaglio)

MH 20-4 T BUGGIE S2-E3  
MH 25-4 T BUGGIE S2-E3  
MSI 20 / 25 / 30 / 35 T BUGGIE S2-E3

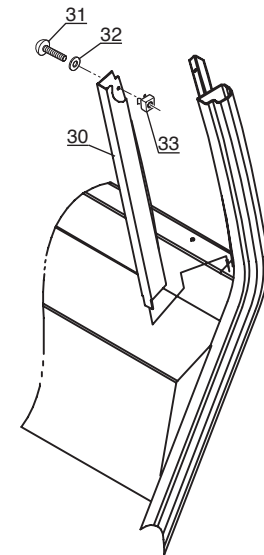
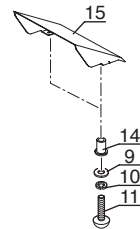
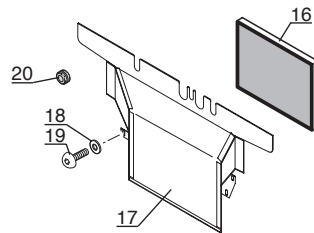
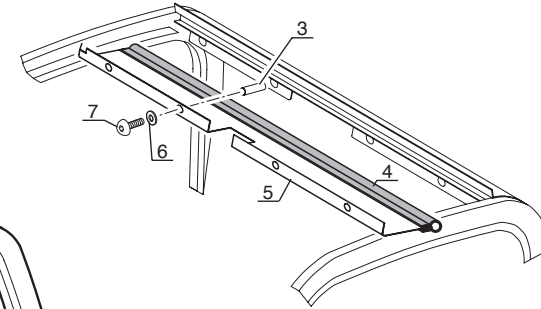
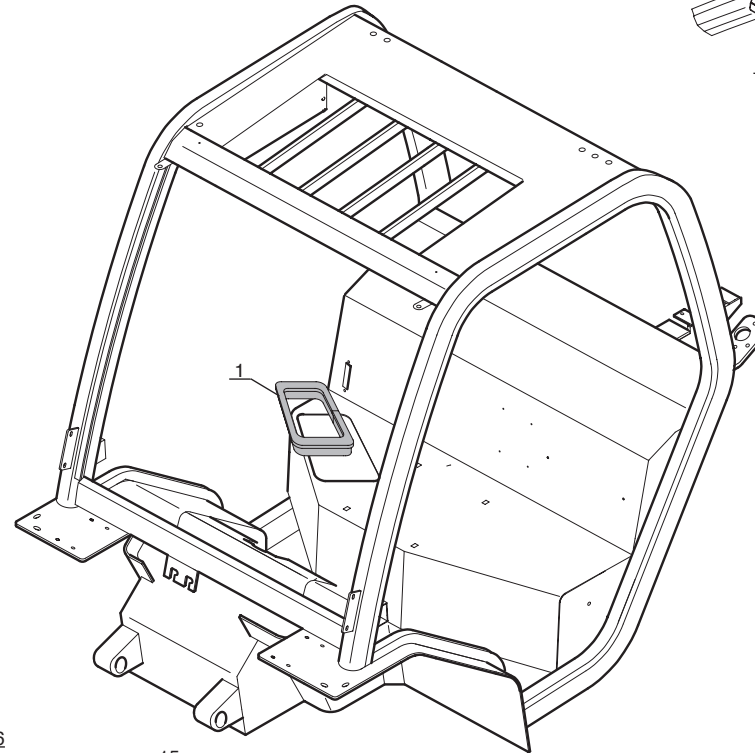
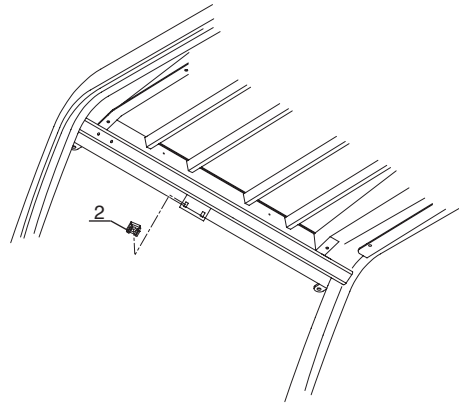



Catalogue : 264511MOD

Qté-Menge-Cant-Qty-Q.ta | 8 AB 912 | M

1

PROTEGE CONDUCTEUR (Détails)  
 FÄHRER SCHUTZVORRICHTUNG (Einzelteile)  
 PROTECTOR CONDUCTOR (Detalles)  
 DRIVER'S OVERHEAD GUARD (Details)  
 PROTEZIONE CONDUCENTE (Dettaglio)

1-	264511MOD	11-
2-		12-
3-		13-
4-		14-
5-		15-
6-		16-
7-		17-
8-		18-
9-		19-
10-		20-

Rep Hinw Fig Item Rif	Numéro Teil-Nr Numero Part-Nr Part-Nr	Désignation Bezeichnung Descripcion Description Descrizione	Qté-Menge-Cant-Qty-Q.ta																			
			1	2	3	4	5	6	7	8	9	10	11	12	13	14	15	16	17	18	19	20
1	603612	Joint profilé Junta perfilada Guarnizione	- Dichtungsstreifen - Weatherstrip -	1																		
2	603300	Insert Pion Inserto	- Stuck - Insert -	2																		
3	563829	Insert de 6 Pion Inserto	- Stuck - Insert -	4																		
4	72468	Joint d'étanchéité Junta de estanqueidad Guarnizione	- Dichtungsring - Seal -	1																		
5	747297	Plaque de fermeture arrière Placa de cierre trasera Piastra di chiusura posteriore-	- Hinter schlussplatte - Rear fastening plate	1																		
6	194673	Rondelle plastique Arandela plástica Rondella plastica	- Plastischeibe - Plastic washer -	4																		
7	183396	Vis CBHc,M 6- 16-ZN NOIR Tornillo Vite	- Schraube - Screw -	4																		
9	29469	Rondelle M 6 ZN Arandela Rondella	- Unterlegscheibe - Washer -	2																		
10	42316	Rondelle W 6 ZN Arandela Rondella	- Unterlegscheibe - Washer -	2																		
11	190807	Vis CBHc,M 6- 30-10.9-ZN5/NOIR- Tornillo Vite	- Schraube - Screw -	2																		
14	563858	Insert Pion Inserto	- Stuck - Insert -	2																		

+



**Catalogue : 264511MOD**

**3**

PROTEGE CONDUCTEUR (Détails)  
 FÄHRER SCHUTZVORRICHTUNG (Einzelteile)  
 PROTECTOR CONDUCTOR (Detalles)  
 DRIVER'S OVERHEAD GUARD (Details)  
 PROTEZIONE CONDUCENTE (Dettaglio)

Qté-Menge-Cant-Qty-Q.ta

**8 AB**

**912**

**M**

1-	264511MOD	11-
2-		12-
3-		13-
4-		14-
5-		15-
6-		16-
7-		17-
8-		18-
9-		19-
10-		20-

Rep Hinw Fig Item Rif	Numéro Teil-Nr Numero Part-Nr Part-Nr	Désignation Bezeichnung Descripcion Description Descrizione
-----------------------------------	---	---

1	2	3	4	5	6	7	8	9	10	11	12	13	14	15	16	17	18	19	20
---	---	---	---	---	---	---	---	---	----	----	----	----	----	----	----	----	----	----	----

		AB DER MASCHINE N° 242133 A PARTIR DE LA MAQUINA N° 242133 FROM MACHINE N° 242133 A PARTIR DA MACCHINA N° 242133
--	--	---

8 AB 913

POUR TYPE DE PROTEGE CONDUCTEUR  
FÜR FÜHRER SCHUTZVORRICHTUNG TYPEN  
PARA TIPO DE PROTECTOR CONDUCTOR  
FOR DRIVER' S OVERHEAD GUARD TYPE  
PER TIPO DI COPRICONDUITTORE

□ 264 511

PROTEGE CONDUCTEUR (Détails)  
FÜHRER SCHUTZVORRICHTUNG (Einzelteile)  
PROTECTOR CONDUCTOR (Detailles)  
DRIVER' S OVERHEAD GUARD (Details)  
PROTEZIONE CONDUCENTE (Dettaglio)

MH 20-4 T BUGGIE S2-E3  
MH 25-4 T BUGGIE S2-E3  
MSI 20 / 25 / 30 / 35 T BUGGIE S2-E3

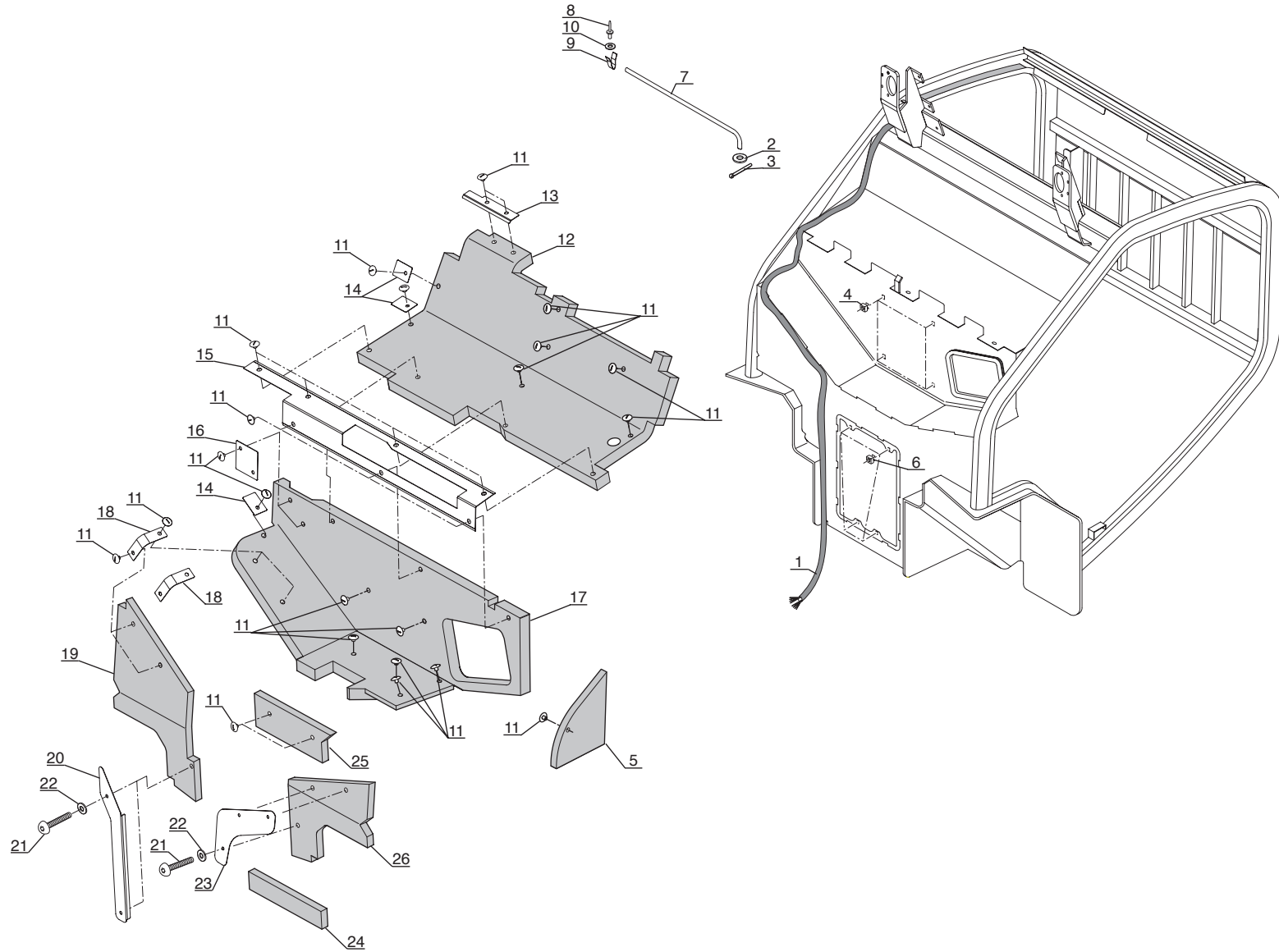

Catalogue : 264511MOD

Qté-Menge-Cant-Qty-Q.ta

8 AB

913

M

1

PROTEGE-CONDUCTEUR (Détails)  
 FÄHRER SCHUTZVORRICHTUNG (Einzelteile)  
 PROTECTOR CONDUCTOR (Detalles)  
 DRIVER'S OVERHEAD GUARD (Details)  
 PROTEZIONE CONDUCENTE (Dettaglio)

1- 264511MOD 11-  
 2- 12-  
 3- 13-  
 4- 14-  
 5- 15-  
 6- 16-  
 7- 17-  
 8- 18-  
 9- 19-  
 10- 20-

Rep Hinw Fig Item Rif	Numéro Teil-Nr Numero Part-Nr Part-Nr	Désignation Bezeichnung Descripcion Description Descrizione	1	2	3	4	5	6	7	8	9	10	11	12	13	14	15	16	17	18	19	20
1	561117	Faisceau principal Haz principal Fascio principale - Haupt Kabelbaum - Main wiring harness -	1																			
2	561140	Rondelle Arandela Rondella - Unterlegscheibe - Washer -	1																			
3	561139	Goupille Pasador Spina - Stift - Pin -	1																			
4	205052	Ecrou Tuerca Dado - Mutter - Nut -	4																			
5	747176	Insonorisant Insonorizador Ammortizzatore - Schalldämpfungmoos - Sound proofing foam -	1																			
6	205057	Ecrou Tuerca Dado - Mutter - Nut -	4																			
7	561137	Béquille de maintien Apoyo Cavalletto di sostegno - Tragstange - Shore -	1																			
8	54568	Rivet Remache Rivetto - Niete - Rivet -	1																			
9	561138	Clip Clip Fermaglio - Klammer - Clip -	1																			
10	28988	Rondelle M 4 ZN Arandela Rondella - Unterlegscheibe - Washer -	1																			
11	603846	Clip Clip Fermaglio - Klammer - Clip -	32																			

+

**Catalogue : 264511MOD**

**Qté-Menge-Cant-Qty-Q.ta**

**8 AB**

**913**

**M**

**2**

PROTEGE-CONDUCTEUR (Détails)  
 FÄHRER SCHUTZVORRICHTUNG (Einzelteile)  
 PROTECTOR CONDUCTOR (Detalles)  
 DRIVER'S OVERHEAD GUARD (Details)  
 PROTEZIONE CONDUCENTE (Dettaglio)

1-	264511MOD	11-
2-		12-
3-		13-
4-		14-
5-		15-
6-		16-
7-		17-
8-		18-
9-		19-
10-		20-

Rep Hinw Fig Item Rif	Numéro Teil-Nr Numero Part-Nr Part-Nr	Désignation Bezeichnung Descripcion Description Descrizione	Qté-Menge-Cant-Qty-Q.ta																			
			1	2	3	4	5	6	7	8	9	10	11	12	13	14	15	16	17	18	19	20
12	747177	Insonorisant Insonorizador Ammortizzatore	-	-	-	-	-	-	-	-	-	-	-	-	-	-	-	-	-	-	-	-
13	747178	Support insonorisant Soporte insonorizador Supporto ammortizzatore	-	-	-	-	-	-	-	-	-	-	-	-	-	-	-	-	-	-	-	-
14	747179	Support insonorisant Soporte insonorizador Supporto ammortizzatore	-	-	-	-	-	-	-	-	-	-	-	-	-	-	-	-	-	-	-	-
15	747180	Support insonorisant Soporte insonorizador Supporto ammortizzatore	-	-	-	-	-	-	-	-	-	-	-	-	-	-	-	-	-	-	-	-
16	747181	Support insonorisant Soporte insonorizador Supporto ammortizzatore	-	-	-	-	-	-	-	-	-	-	-	-	-	-	-	-	-	-	-	-
17	747182	Insonorisant inférieur Insonorizador trasera Ammortizzatore inferiore	-	-	-	-	-	-	-	-	-	-	-	-	-	-	-	-	-	-	-	-
18	747183	Support insonorisant Soporte insonorizador Supporto ammortizzatore	-	-	-	-	-	-	-	-	-	-	-	-	-	-	-	-	-	-	-	-
19	747184	Insonorisant gauche Insonorizador izquierdo Ammortizzatore sinistro	-	-	-	-	-	-	-	-	-	-	-	-	-	-	-	-	-	-	-	-
20	561120	Support Soporte Supporto	-	-	-	-	-	-	-	-	-	-	-	-	-	-	-	-	-	-	-	-
21	552787	Vis Tornillo Vite	-	-	-	-	-	-	-	-	-	-	-	-	-	-	-	-	-	-	-	-
22	197472	Rondelle Arandela Rondella	-	-	-	-	-	-	-	-	-	-	-	-	-	-	-	-	-	-	-	-

+

**Catalogue : 264511MOD**

3

PROTEGE-CONDUCTEUR (Détails)  
 FÄHRER SCHUTZVORRICHTUNG (Einzelteile)  
 PROTECTOR CONDUCTOR (Detalles)  
 DRIVER'S OVERHEAD GUARD (Details)  
 PROTEZIONE CONDUCENTE (Dettaglio)

Qté-Menge-Cant-Qty-Q.ta

8 AB

913

M

Rep Hinw Fig Item Rif	Numéro Teil-Nr Numero Part-Nr Part-Nr	Désignation Bezeichnung Descripcion Description Descrizione	Qté-Menge-Cant-Qty-Q.ta																			
			1	2	3	4	5	6	7	8	9	10	11	12	13	14	15	16	17	18	19	20
			1-	264511MOD	11-																	
			2-		12-																	
			3-		13-																	
			4-		14-																	
			5-		15-																	
			6-		16-																	
			7-		17-																	
			8-		18-																	
			9-		19-																	
			10-		20-																	
23	564607	Support Soporte Supporto	- Träger - Bracket -	1																		
24	561124	Insonorisant Insonorizador Ammortizzatore	- Schalldämpfungmoos - Sound proofing foam -	1																		
25	747185	Insonorisant Insonorizador Ammortizzatore	- Schalldämpfungmoos - Sound proofing foam -	1																		
26	747186	Insonorisant droit Insonorizador derecho Ammortizzatore destro  * MSI 20 T BUGGIE S1-E2 MSI 25 T BUGGIE S1-E2 MSI 30 T BUGGIE S1-E2  A PARTIR DE LA MACHINE N° 242133 AB DER MASCHINE N° 242133 A PARTIR DE LA MAQUINA N° 242133 FROM MACHINE N° 242133 A PARTIR DA MACCHINA N° 242133	- Recht shalldämpfungmoos - R.H. sound proofing foam -	1																		

9 AB 103

INSONORISATION  
SCHALLDAMMUNG  
INSONORIZACION  
SOUND-PROOFING  
INSONORIZAZIONE

MH 20-4 T BUGGIE S2-E3  
MH 25-4 T BUGGIE S2-E3  
MSI 20 / 25 / 30 / 35 T S2-E3  
MSI 20 / 25 / 30 / 35 T BUGGIE S2-E3

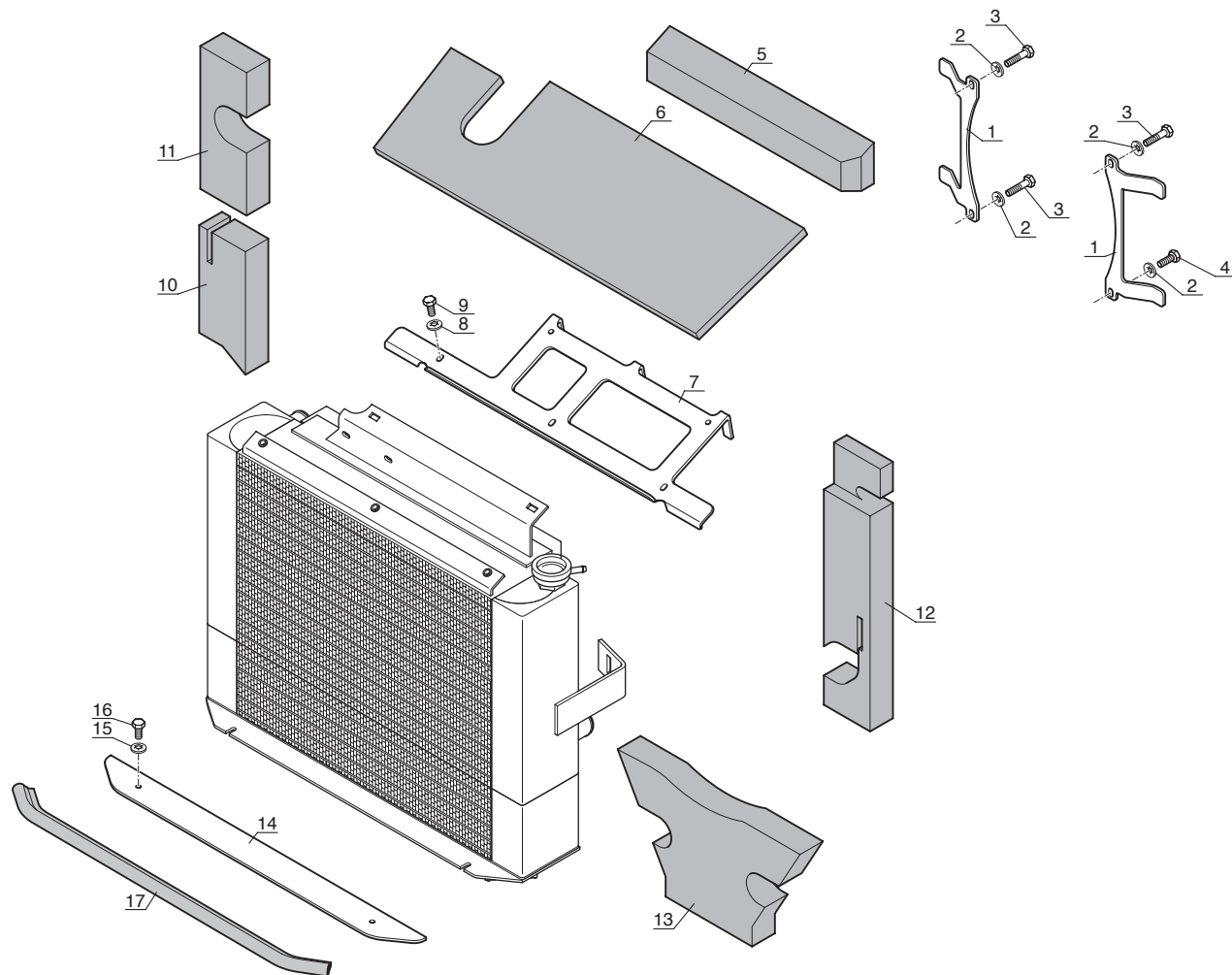



Catalogue : 647000

Qté-Menge-Cant-Qty-Q.ta

9 AB

103

M

1	INSONORISATION SCHALLDÄMMUNG INSONORIZACION SOUND-PROOFING INSONORIZZAZIONE																						
	Rep Hinw Fig Item Rif	Numéro Teil-Nr Numero Part-Nr Part-Nr	Désignation Bezeichnung Descripcion Description Descrizione	1	2	3	4	5	6	7	8	9	10	11	12	13	14	15	16	17	18	19	20
1	270547	Support insonorisant Soporte insonorizador Supporto ammortizzatore	- Schalldämpfungmoos träger - Sound proofing foam bracket -	2	2	2	2	2	2	2	2	2	2										
2	174132	Rondelle JZC 6 CAD.BICH Arandela Rondella	- Unterlegscheibe - Washer -	4	4	4	4	4	4	4	4	4	4										
3	58525	Vis H,M 6- 25-8.8-ZN5/C Tornillo Vite	- Schraube - Screw -	3	3	3	3	3	3	3	3	3	3										
4	46668	Vis H,M 6- 20-8.8-ZN5/C Tornillo Vite	- Schraube - Screw -	1	1	1	1	1	1	1	1	1	1										
5	270537	Insonorisant supérieur Insonorizador superior Ammortizzatore superiore	- Ober Schalldämpfungmoos - Upper sound proofing foam -	1	1	1	1	1	1	1	1	1	1										
6	270536	Insonorisant supérieur Insonorizador superior Ammortizzatore superiore	- Ober Schalldämpfungmoos - Upper sound proofing foam -	1	1	1	1	1	1	1	1	1	1										
7	270546	Support insonorisant Soporte insonorizador Supporto ammortizzatore	- Schalldämpfungmoos träger - Sound proofing foam bracket -	1	1	1	1	1	1	1	1	1	1										
8	174132	Rondelle JZC 6 CAD.BICH Arandela Rondella	- Unterlegscheibe - Washer -	5	5	5	5	5	5	5	5	5	5										
9	46668	Vis H,M 6- 20-8.8-ZN5/C Tornillo Vite	- Schraube - Screw -	5	5	5	5	5	5	5	5	5	5										
10	270540	Insonorisant inférieur Insonorizador trasera Ammortizzatore inferiore	- Hinter Schalldämpfungmoos - Lower sound proofing foam -	1	1	1	1	1	1	1	1	1	1										
11	270538	Insonorisant supérieur Insonorizador superior Ammortizzatore superiore	- Ober Schalldämpfungmoos - Upper sound proofing foam -	1	1	1	1	1	1	1	1	1	1										

+

Catalogue : 647000

2

INSONORISATION  
SCHALLDÄMMUNG  
INSONORIZACION  
SOUND-PROOFING  
INSONORIZZAZIONE

Qté-Menge-Cant-Qty-Q.ta

9 AB

103

M

1- MH20-4T BUG. S2-E3 11-  
2- MH25-4T BUG. S2-E3 12-  
3- MSI 20T S2-E3 13-  
4- MSI 20T BUG. S2-E3 14-  
5- MSI 25T S2-E3 15-  
6- MSI 25T BUG. S2-E3 16-  
7- MSI 30T S2-E3 17-  
8- MSI 30T BUG. S2-E3 18-  
9- MSI 35T S2-E3 19-  
10- MSI 35T BUG. S2-E3 20-

Rep Hinw Fig Item Rif	Numéro Teil-Nr Numero Part-Nr Part-Nr	Désignation Bezeichnung Descripcion Description Descrizione																				
			1	2	3	4	5	6	7	8	9	10	11	12	13	14	15	16	17	18	19	20
12	270541	Insonorisant droit Insonorizador derecho Ammortizzatore destro - Recht shalldämpfungmoos - R.H. sound proofing foam -	1	1	1	1	1	1	1	1	1	1										
13	270542	Insonorisant inférieur Insonorizador trasera Ammortizzatore inferiore - Hinter Schalldämpfungmoos - Lower sound proofing foam -	1	1	1	1	1	1	1	1	1	1										
14	270545	Support insonorisant Soporte insonorizador Supporto ammortizzatore - Schalldämpfungmoos träger - Sound proofing foam bracket -	1	1	1	1	1	1	1	1	1	1										
15	174132	Rondelle JZC 6 CAD.BICH Arandela Rondella - Unterlegscheibe - Washer -	2	2	2	2	2	2	2	2	2	2										
16	236381	Vis H,M 6- 14-8.8-ZN/5C Tornillo Vite - Schraube - Screw -	2	2	2	2	2	2	2	2	2	2										
17	274732	Joint profilé Junta perfilada Guarnizióne - Dichtungsstreifen - Weatherstrip -	1	1	1	1	1	1	1	1	1	1										



10 AA 741

HYDRAULIQUE (Circuit principal)  
 HYDRAULIK (Hauptkreis)  
 HIDRAULICO (Circuito principal)  
 HYDRAULIC (Principal circuit)  
 IDRAULICO (Circuito principale)

MH 20-4 T BUGGIE S2-E3  
 MH 25-4 T BUGGIE S2-E3  
 MSI 20 / 25 T S2-E3  
 MSI 20 / 25 T BUGGIE S2-E3

POUR FLEXIBLE ET RACCORD  
 FÜR SCHLAUCH UND VERSCHRAUBUNG  
 PARA FLEXIBLE Y RACOR  
 FOR HOSE AND CONNECTION  
 PER FLESSIBILE E RACCORDO

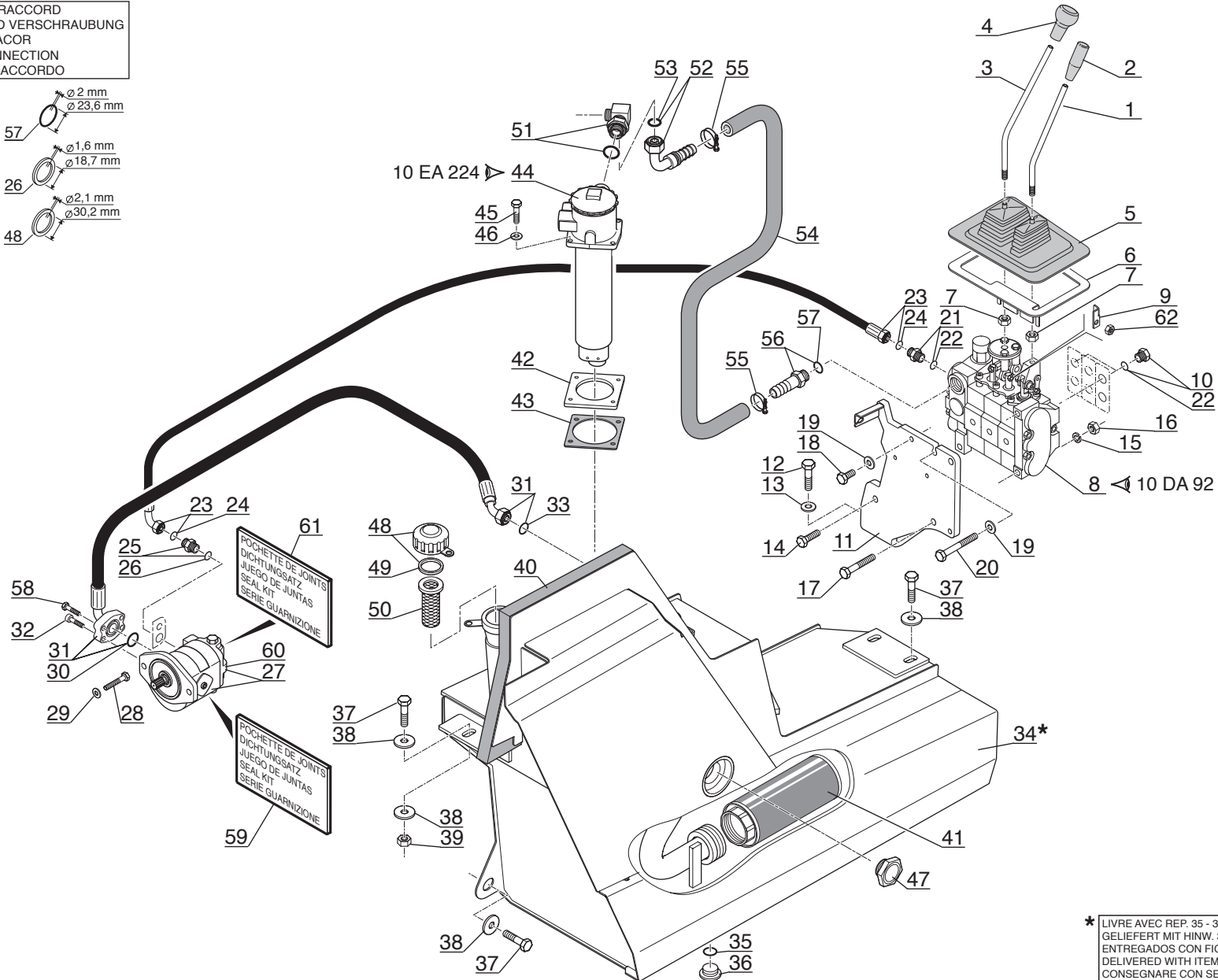
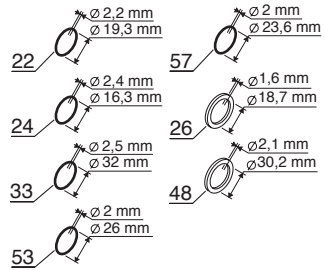

\* LIVRE AVEC REP. 35 - 36 - 40 - 48 - 49 - 50  
 GELIEFERT MIT HINW. 35 - 36 - 40 - 48 - 49 - 50  
 ENTREGADOS CON FIG. 35 - 36 - 40 - 48 - 49 - 50  
 DELIVERED WITH ITEM. 35 - 36 - 40 - 48 - 49 - 50  
 CONSEGNARE CON SEQU. 35 - 36 - 40 - 48 - 49 - 50

Catalogue : 647000

1	HYDRAULIQUE (Circuit principal) HYDRAULIK (Hauptkreis) HIDRAULICO (Circuito principal) HYDRAULIC (Principal circuit) IDRAULICO (Circuito principale)			Qté-Menge-Cant-Qty-Q.ta						10 AA		741		M									
	Rep Hinw Fig Item Rif	Numéro Teil-Nr Numero Part-Nr Part-Nr	Désignation Bezeichnung Descripcion Description Descrizione	1	2	3	4	5	6	7	8	9	10	11	12	13	14	15	16	17	18	19	20
1	208546	Levier Palanca Leva	- Hebel - Lever -	1	1	1	1	1	1														
2	202226	Poignée Agarrador Maniglia	- Handgriff - Handle -	1	1	1	1	1	1														
3	210698	Levier Palanca Leva	- Hebel - Lever -	1	1	1	1	1	1														
4	209640	Boule Bola Bulbo	- Knopf - Ball -	1	1	1	1	1	1														
5	215533	Soufflet Fuelle Soffietto	- Blasebalg - Bellows -	1	1	1	1	1	1														
6	215882	Support Soporte Supporto	- Träger - Bracket -	1	1	1	1	1	1														
7	58548	Ecrou H ,M12 C 8 ZN..C Tuerca Dado	- Mutter - Nut -	2	2	2	2	2	2														
8	219440	Distributeur complet Kompletter kommandosteuerventil Distribuidor completo Distributore completo	- Complete valve bank -	1	1	1	1	1	1														
9	206044	Butée Tope Battuta	- Anschlag - Stop -	1	1	1	1	1	1														
10	175743	Bouchon Tapón Tappo	- Stopfen - Plug -	3	3	3	3	3	3														
11	241136	Support distributeur Soporte distribuidor Supporto distributore	- Kommandosteuerventil träger - Valve bank bracket -	1	1	1	1	1	1														

Catalogue : 647000

2

HYDRAULIQUE (Circuit principal)  
 HYDRAULIK (Hauptkreis)  
 HIDRAULICO (Circuito principal)  
 HYDRAULIC (Principal circuit)  
 IDRAULICO (Circuito principale)

Qté-Menge-Cant-Qty-Q.ta

10 AA

741

M

1-	MH20-4T	BUG. S2-E3	11-
2-	MH25-4T	BUG. S2-E3	12-
3-	MSI 20T	S2-E3	13-
4-	MSI 20T	BUG. S2-E3	14-
5-	MSI 25T	S2-E3	15-
6-	MSI 25T	BUG. S2-E3	16-
7-	MSI 30T	S2-E3	17-
8-	MSI 30T	BUG. S2-E3	18-
9-	MSI 35T	S2-E3	19-
10-	MSI 35T	BUG. S2-E3	20-

Rep Hinw Fig Item Rif	Numéro Teil-Nr Numero Part-Nr Part-Nr	Désignation Bezeichnung Descripcion Description Descrizione	1	2	3	4	5	6	7	8	9	10	11	12	13	14	15	16	17	18	19	20	
12	63547	Vis H,M12- 30-8.8-ZN8/C Tornillo Vite - Schraube - Screw -	2	2	2	2	2	2															
13	61676	Rondelle M 12 ZN Arandela Rondella - Unterlegscheibe - Washer -	2	2	2	2	2	2															
14	58536	Vis H,M10- 45-8.8-ZN8/C Tornillo Vite - Schraube - Screw -	1	1	1	1	1	1															
15	42232	Rondelle W10 ZN Arandela Rondella - Unterlegscheibe - Washer -	3	3	3	3	3	3															
16	56354	Ecrou H ,M10 zingué Tuerca Dado - Mutter - Nut -	3	3	3	3	3	3															
17	58538	Vis H,M10- 70-8.8-ZN8/C Tornillo Vite - Schraube - Screw -	1	1	1	1	1	1															
18	60360	Vis H,M10- 16-8.8-ZN8/C Tornillo Vite - Schraube - Screw -	1	1	1	1	1	1															
19	29437	Rondelle M 10 ZN Arandela Rondella - Unterlegscheibe - Washer -	2	2	2	2	2	2															
20	40760	Vis H,M10- 80-8.8-ZN8/C Tornillo Vis - Schraube - Screw -	1	1	1	1	1	1															
21	167923	Raccord Union Racor Raccordo - Verschraubung - Connection -	1	1	1	1	1	1															
22	169373	Joint torique Junta tórica Anello OR - "0" ring - "0" ring -	X	X	X	X	X	X															

+

Catalogue : 647000

3	HYDRAULIQUE (Circuit principal) HYDRAULIK (Hauptkreis) HIDRAULICO (Circuito principal) HYDRAULIC (Principal circuit) IDRAULICO (Circuito principale)			Qté-Menge-Cant-Qty-Q.ta						10 AA		741		M									
	Rep Hinw Fig Item Rif	Numéro Teil-Nr Numero Part-Nr Part-Nr	Désignation Bezeichnung Descripcion Description Descrizione	1	2	3	4	5	6	7	8	9	10	11	12	13	14	15	16	17	18	19	20
23	203676	Flexible (Lg 600) Flexible Flessibile	- Schlauch - Hose -	1	1	1	1	1	1														
24	86788	Joint torique Junta tórica Anello OR	- "0" ring - "0" ring -	X	X	X	X	X	X														
25	200480	Raccord Union Racor Raccordo	- Verschraubung - Connection -	1	1	1	1	1	1														
26	184787	Joint d'étanchéité Junta de estanqueidad Guarnizione di tenuta	- Dichtungsring - Seal -	X	X	X	X	X	X														
27	247580	Pompe complète Bomba completa Pompa completa	- Kompletter Pumpe - Complete Pump -	1	1	1	1	1	1														
28	58546	Vis H,M12- 35-8.8-ZN8/C Tornillo Vite	- Schraube - Screw -	2	2	2	2	2	2														
29	61676	Rondelle M 12 ZN Arandela Rondella	- Unterlegscheibe - Washer -	2	2	2	2	2	2														
30	170583	Joint torique Junta tórica Anello OR	- "0" ring - "0" ring -	1	1	1	1	1	1														
31	247667	Flexible (Lg 910) Flexible Flessibile	- Schlauch - Hose -	1	1	1	1	1	1														
32	51510	Vis CHc,M10- 25 zinguée Tornillo Vite	- Schraube - Screw -	3	3	3	3	3	3														
33	194813	Joint torique Junta tórica Anello OR	- "0" ring - "0" ring -	1	1	1	1	1	1														

Catalogue : 647000

Qté-Menge-Cant-Qty-Q.ta

10 AA

741

M

4

HYDRAULIQUE (Circuit principal)  
 HYDRAULIK (Hauptkreis)  
 HIDRAULICO (Circuito principal)  
 HYDRAULIC (Principal circuit)  
 IDRAULICO (Circuito principale)

1- MH20-4T BUG. S2-E3 11-  
 2- MH25-4T BUG. S2-E3 12-  
 3- MSI 20T S2-E3 13-  
 4- MSI 20T BUG. S2-E3 14-  
 5- MSI 25T S2-E3 15-  
 6- MSI 25T BUG. S2-E3 16-  
 7- MSI 30T S2-E3 17-  
 8- MSI 30T BUG. S2-E3 18-  
 9- MSI 35T S2-E3 19-  
 10- MSI 35T BUG. S2-E3 20-

Rep Hinw Fig Item Rif	Numéro Teil-Nr Numero Part-Nr Part-Nr	Désignation Bezeichnung Descripcion Description Descrizione	1	2	3	4	5	6	7	8	9	10	11	12	13	14	15	16	17	18	19	20
34	265222	Bac à huile - Olbehälter Tanque de aceite - Oil tank Serbatoio olio -	1	1	1	1	1	1														
35	189536	Joint d'étanchéité - Dichtungsring Junta de estanqueidad - Seal Guarnizióne -	1	1	1	1	1	1														
36	189535	Bouchon - Stopfen Tapón - Plug Tappo -	1	1	1	1	1	1														
37	63547	Vis H,M12- 30-8.8-ZN8/C - Schraube Tornillo - Screw Vite -	4	4	4	4	4	4														
38	44026	Rondelle SP 13 x 45 x 4 ZN - Unterlegscheibe Arandela - Washer Rondella -	5	5	5	5	5	5														
39	58548	Ecrou H ,M12 C 8 ZN..C - Mutter Tuerca - Nut Dado -	1	1	1	1	1	1														
40	264518	Insonorisant - Schalldämpfungmoos Insonorizador - Sound proofing foam Ammortizzatore -	1	1	1	1	1	1														
41	77402	Crépine du circuit principal - Seiher hauptkreis Filtro de paso de circuito principal Principal circuit strainer Pigna circuito principale -	1	1	1	1	1	1														
42	247208	Support filtre - Filter träger Soporte filtro - Filter bracket Supporto filtro -	1	1	1	1	1	1														
43	247588	Joint d'étanchéité - Dichtungsring Junta de estanqueidad - Seal Guarnizióne di tenuta -	1	1	1	1	1	1														
44	246904	Filtre à huile retour hydraulique complet Kompletter hydraulik ruckgang ölfilter Filtro de aceite retorno hidraulico completo Complete hydraulic return oil filter Filtro die idraulico completo -	1	1	1	1	1	1														

+



Catalogue : 647000

5	HYDRAULIQUE (Circuit principal) HYDRAULIK (Hauptkreis) HIDRAULICO (Circuito principal) HYDRAULIC (Principal circuit) IDRAULICO (Circuito principale)			Qté-Menge-Cant-Qty-Q.ta										10 AA	741	M							
	Rep Hinw Fig Item Rif	Numéro Teil-Nr Numero Part-Nr Part-Nr	Désignation Bezeichnung Description Descrizione	1	2	3	4	5	6	7	8	9	10	11	12	13	14	15	16	17	18	19	20
45	58530	Vis H,M 8- 45-8.8-ZN8/C Tornillo Vite	- Schraube - Screw -	4	4	4	4	4	4														
46	61674	Rondelle M 8 ZN Arandela Rondella	- Unterlegscheibe - Washer -	4	4	4	4	4	4														
47	488236	Jauge Galga Livello	- Eichmass - Gauge -	1	1	1	1	1	1														
48	62415	Bouchon filtre de remplissage Tapón filtro de llenado Tappo filtro di riempimento	- Einfullfilterverschluss - Filling plug filter -	1	1	1	1	1	1														
49	1071	Joint d'étanchéité Junta de estanqueidad Guarnizióne	- Dichtungsring - Seal -	1	1	1	1	1	1														
50	62845	Filtre Filtro Filtro	- Filter - Filter -	1	1	1	1	1	1														
51	247581	Raccord Racor Raccordo	- Verschraubung - Connection -	1	1	1	1	1	1														
52	215921	Raccord Coudé Cranté Racor Raccordo	- Verschraubung - Connection -	1	1	1	1	1	1														
53	190019	Joint torique Junta tórica Anello OR	- "O" ring - "O" ring -	X	X	X	X	X	X														
54	252073	Durit (Lg 200) Tubo flexible Manicotto	- Schlauch - Hose -	1	1	1	1	1	1														
55	71940	Collier Abrazadera Fascetta	- Spannschelle - Clamp -	2	2	2	2	2	2														

Catalogue : 647000

6

HYDRAULIQUE (Circuit principal)  
 HYDRAULIK (Hauptkreis)  
 HIDRAULICO (Circuito principal)  
 HYDRAULIC (Principal circuit)  
 IDRAULICO (Circuito principale)

Qté-Menge-Cant-Qty-Q.ta

10 AA

741

M

1-	MH20-4T	BUG. S2-E3	11-
2-	MH25-4T	BUG. S2-E3	12-
3-	MSI 20T	S2-E3	13-
4-	MSI 20T	BUG. S2-E3	14-
5-	MSI 25T	S2-E3	15-
6-	MSI 25T	BUG. S2-E3	16-
7-	MSI 30T	S2-E3	17-
8-	MSI 30T	BUG. S2-E3	18-
9-	MSI 35T	S2-E3	19-
10-	MSI 35T	BUG. S2-E3	20-

Rep Hinw Fig Item Rif	Numéro Teil-Nr Numero Part-Nr Part-Nr	Désignation Bezeichnung Description Descrizione	1	2	3	4	5	6	7	8	9	10	11	12	13	14	15	16	17	18	19	20
56	232790	Raccord Union Cranté Racor Raccordo - Verschraubung - Connection -	1	1	1	1	1	1														
57	169372	Joint torique Junta torica Anello OR - "O" ring - "O" ring -	X	X	X	X	X	X														
58	5804	Vis H,M10- 25-8.8-ZN8/C Tornillo Vite - Schraube - Screw -	1	1	1	1	1	1														
59	703042	Pochette de joints Juego de juntas Kit guarnizióni - Dichtungssatz - Seal kit -	1	1	1	1	1	1														
60	563486	Valve Válvula Valvola - Ventil - Valve -	1	1	1	1	1	1														
61	604583	Pochette de joints (Valve) Juego de juntas (Válvula) Kit guarnizióne (Valvola) - Dichtungssatz (Ventil) - Seal kit (Valve) -	1	1	1	1	1	1														
62	25714	Ecrou H ,M 6 ZN Tuerca Dado - Mutter - Nut -	1	1	1	1	1	1														



10 AA 742

HYDRAULIQUE (Circuit principal)  
 HYDRAULIK (Hauptkreis)  
 HIDRAULICO (Circuito principal)  
 HYDRAULIC (Principal circuit)  
 IDRAULICO (Circuito principale)

MSI 30 / 35 T S2-E3  
 MSI 30 / 35 T BUGGIE S2-E3

POUR FLEXIBLE ET RACCORD  
 FÜR SCHLAUCH UND VERSCHRAUBUNG  
 PARA FLEXIBLE Y RACOR  
 FOR HOSE AND CONNECTION  
 PER FLESSIBILE E RACCORDO

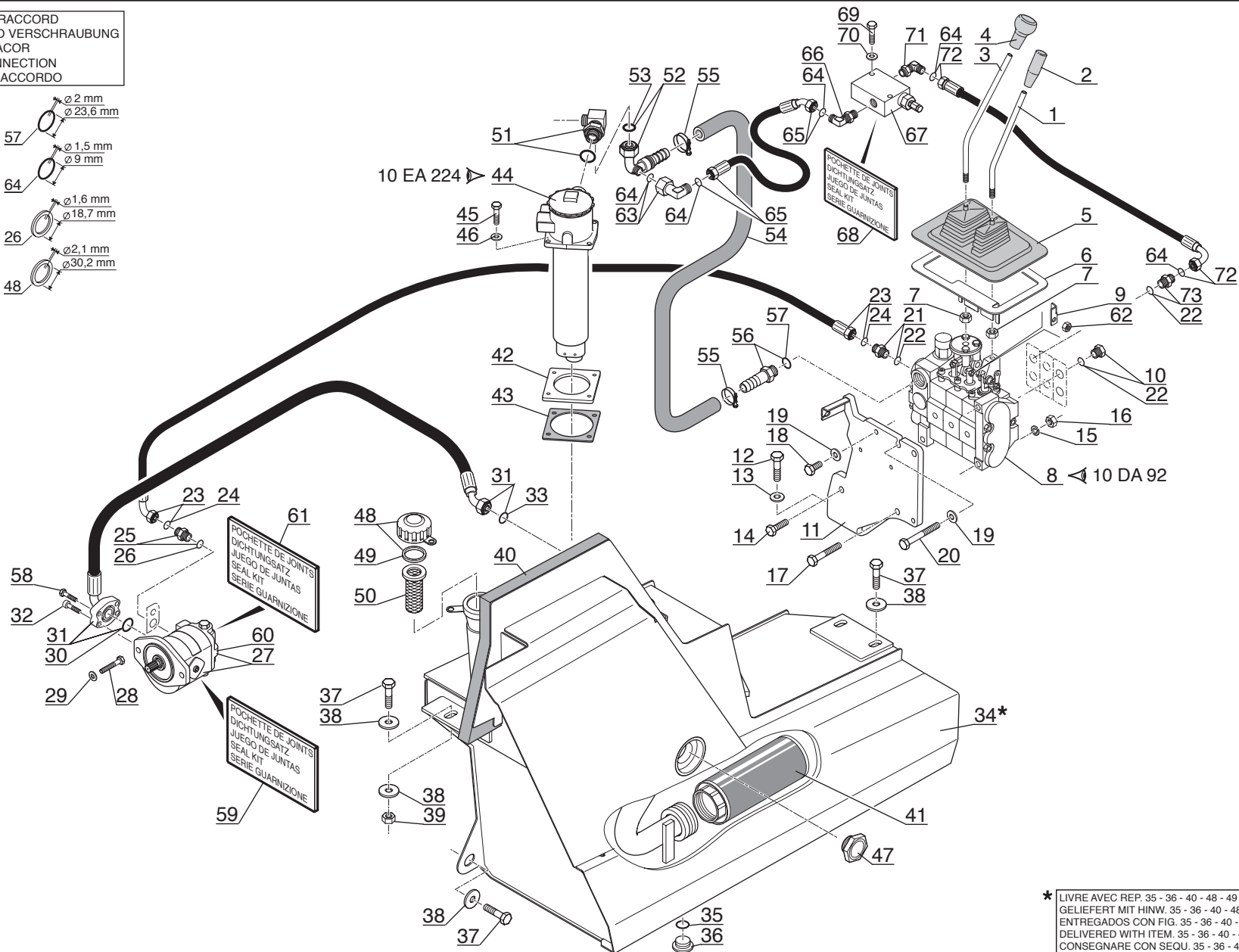
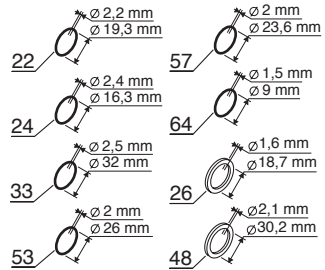

\* LIVRE AVEC REP. 35 - 36 - 40 - 48 - 49 - 50  
 GELIEFERT MIT HINW. 35 - 36 - 40 - 48 - 49 - 50  
 ENTREGADOS CON FIG. 35 - 36 - 40 - 48 - 49 - 50  
 DELIVERED WITH ITEM. 35 - 36 - 40 - 48 - 49 - 50  
 CONSEGNARE CON SEQU. 35 - 36 - 40 - 48 - 49 - 50

Catalogue : 647000

1	HYDRAULIQUE (Circuit principal) HYDRAULIK (Hauptkreis) HIDRAULICO (Circuito principal) HYDRAULIC (Principal circuit) IDRAULICO (Circuito principale)			Qté-Menge-Cant-Qty-Q.ta										10 AA	742	M							
	Rep Hinw Fig Item Rif	Numéro Teil-Nr Numero Part-Nr Part-Nr	Désignation Bezeichnung Descripcion Description Descrizione	1	2	3	4	5	6	7	8	9	10	11	12	13	14	15	16	17	18	19	20
1	208546	Levier Palanca Leva	- Hebel - Lever -							1	1	1	1										
2	202226	Poignée Agarrador Maniglia	- Handgriff - Handle -							1	1	1	1										
3	210698	Levier Palanca Leva	- Hebel - Lever -							1	1	1	1										
4	209640	Boule Bola Bulbo	- Knopf - Ball -							1	1	1	1										
5	215533	Soufflet Fuelle Soffietto	- Blasebalg - Bellows -							1	1	1	1										
6	215882	Support Soporte Supporto	- Träger - Bracket -							1	1	1	1										
7	58548	Ecrou H ,M12 C 8 ZN..C Tuerca Dado	- Mutter - Nut -							2	2	2	2										
8	219440	Distributeur complet Kompletter kommandosteuerventil Distribuidor completo Distributore completo	- Complete valve bank -							1	1	1	1										
9	206044	Butée Tope Battuta	- Anschlag - Stop -							1	1	1	1										
10	175743	Bouchon Tapón Tappo	- Stopfen - Plug -							2	2	2	2										
11	241136	Support distributeur Soporte distribuidor Supporto distributore	- Kommandosteuerventil träger - Valve bank bracket -							1	1	1	1										

Catalogue : 647000

2

HYDRAULIQUE (Circuit principal)  
 HYDRAULIK (Hauptkreis)  
 HIDRAULICO (Circuito principal)  
 HYDRAULIC (Principal circuit)  
 IDRAULICO (Circuito principale)

Qté-Menge-Cant-Qty-Q.ta

10 AA

742

M

1-	MH20-4T	BUG. S2-E3	11-
2-	MH25-4T	BUG. S2-E3	12-
3-	MSI 20T	S2-E3	13-
4-	MSI 20T	BUG. S2-E3	14-
5-	MSI 25T	S2-E3	15-
6-	MSI 25T	BUG. S2-E3	16-
7-	MSI 30T	S2-E3	17-
8-	MSI 30T	BUG. S2-E3	18-
9-	MSI 35T	S2-E3	19-
10-	MSI 35T	BUG. S2-E3	20-

Rep Hinw Fig Item Rif	Numéro Teil-Nr Numero Part-Nr Part-Nr	Désignation Bezeichnung Description Descrizione	1	2	3	4	5	6	7	8	9	10	11	12	13	14	15	16	17	18	19	20	
12	63547	Vis H,M12- 30-8.8-ZN8/C Tornillo Vite - Schraube - Screw -							2	2	2	2											
13	61676	Rondelle M 12 ZN Arandela Rondella - Unterlegscheibe - Washer -							2	2	2	2											
14	58536	Vis H,M10- 45-8.8-ZN8/C Tornillo Vite - Schraube - Screw -							1	1	1	1											
15	42232	Rondelle W10 ZN Arandela Rondella - Unterlegscheibe - Washer -							3	3	3	3											
16	56354	Ecrou H ,M10 zingué Tuerca Dado - Mutter - Nut -							3	3	3	3											
17	58538	Vis H,M10- 70-8.8-ZN8/C Tornillo Vite - Schraube - Screw -							1	1	1	1											
18	60360	Vis H,M10- 16-8.8-ZN8/C Tornillo Vite - Schraube - Screw -							1	1	1	1											
19	29437	Rondelle M 10 ZN Arandela Rondella - Unterlegscheibe - Washer -							2	2	2	2											
20	40760	Vis H,M10- 80-8.8-ZN8/C Tornillo Vis - Schraube - Screw -							1	1	1	1											
21	167923	Raccord Union Racor Raccordo - Verschraubung - Connection -							1	1	1	1											
22	169373	Joint torique Junta tórica Anello OR - "O" ring - "O" ring -							X	X	X	X											

+

Catalogue : 647000

3	HYDRAULIQUE (Circuit principal) HYDRAULIK (Hauptkreis) HIDRAULICO (Circuito principal) HYDRAULIC (Principal circuit) IDRAULICO (Circuito principale)			Qté-Menge-Cant-Qty-Q.ta										10 AA		742		M					
	Rep Hinw Fig Item Rif	Numéro Teil-Nr Numero Part-Nr Part-Nr	Désignation Bezeichnung Description Descrizione	1	2	3	4	5	6	7	8	9	10	11	12	13	14	15	16	17	18	19	20
23	203676	Flexible (Lg 600) Flexible Flessibile	- Schlauch - Hose -							1	1	1	1										
24	86788	Joint torique Junta tórica Anello OR	- "0" ring - "0" ring -							X	X	X	X										
25	200480	Raccord Union Racor Raccordo	- Verschraubung - Connection -							1	1	1	1										
26	184787	Joint d'étanchéité Junta de estanqueidad Guarnizione di tenuta	- Dichtungsring - Seal -							X	X	X	X										
27	247580	Pompe complète Bomba completa Pompa completa	- Kompletter Pumpe - Complete Pump -							1	1	1	1										
28	58546	Vis H,M12- 35-8.8-ZN8/C Tornillo Vite	- Schraube - Screw -							2	2	2	2										
29	61676	Rondelle M 12 ZN Arandela Rondella	- Unterlegscheibe - Washer -							2	2	2	2										
30	170583	Joint torique Junta tórica Anello OR	- "0" ring - "0" ring -							1	1	1	1										
31	247667	Flexible (Lg 910) Flexible Flessibile	- Schlauch - Hose -							1	1	1	1										
32	51510	Vis CHc,M10- 25 zinguée Tornillo Vite	- Schraube - Screw -							3	3	3	3										
33	194813	Joint torique Junta tórica Anello OR	- "0" ring - "0" ring -							1	1	1	1										

Catalogue : 647000

4	HYDRAULIQUE (Circuit principal) HYDRAULIK (Hauptkreis) HIDRAULICO (Circuito principal) HYDRAULIC (Principal circuit) IDRAULICO (Circuito principale)			Qté-Menge-Cant-Qty-Q.ta										10 AA		742		M					
	Rep Hinw Fig Item Rif	Numéro Teil-Nr Numero Part-Nr Part-Nr	Désignation Bezeichnung Descripcion Description Descrizione	1	2	3	4	5	6	7	8	9	10	11	12	13	14	15	16	17	18	19	20
34	265222	Bac à huile Tanque de aceite Serbatoio olio	- Ölbehälter - Oil tank -							1	1	1	1										
35	189536	Joint d'étanchéité Junta de estanqueidad Guarnizióne	- Dichtungsring - Seal -							1	1	1	1										
36	189535	Bouchon Tapón Tappo	- Stopfen - Plug -							1	1	1	1										
37	63547	Vis H,M12- 30-8.8-ZN8/C Tornillo Vite	- Schraube - Screw -							4	4	4	4										
38	44026	Rondelle SP 13 x 45 x 4 ZN Arandela Rondella	- Unterlegscheibe - Washer -							5	5	5	5										
39	58548	Ecrou H ,M12 C 8 ZN..C Tuerca Dado	- Mutter - Nut -							1	1	1	1										
40	264518	Insonorisant Insonorizador Ammortizzatore	- Schalldämpfungmoos - Sound proofing foam -							1	1	1	1										
41	77402	Crépine du circuit principal Filtro de paso de circuito principal Principal circuit strainer Pigna circuito principale	- Seiher hauptkreis - -							1	1	1	1										
42	247208	Support filtre Soporte filtro Supporto filtro	- Filter träger - Filter bracket -							1	1	1	1										
43	247588	Joint d'étanchéité Junta de estanqueidad Guarnizióne di tenuta	- Dichtungsring - Seal -							1	1	1	1										
44	246904	Filtre à huile retour hydraulique complet Kompletter hydraulik ruckgang ölfilter Filtro de aceite retorno hidraulico completo Complete hydraulic return oil filter Filtro die idraulico completo	- - - -							1	1	1	1										



Catalogue : 647000

5	HYDRAULIQUE (Circuit principal) HYDRAULIK (Hauptkreis) HIDRAULICO (Circuito principal) HYDRAULIC (Principal circuit) IDRAULICO (Circuito principale)			Qté-Menge-Cant-Qty-Q.ta										10 AA	742	M							
	Rep Hinw Fig Item Rif	Numéro Teil-Nr Numero Part-Nr Part-Nr	Désignation Bezeichnung Description Descrizione	1	2	3	4	5	6	7	8	9	10	11	12	13	14	15	16	17	18	19	20
45	58530	Vis H,M 8- 45-8.8-ZN8/C Tornillo Vite	- Schraube - Screw -							4	4	4	4										
46	61674	Rondelle M 8 ZN Arandela Rondella	- Unterlegscheibe - Washer -							4	4	4	4										
47	488236	Jauge Galga Livello	- Eichmass - Gauge -							1	1	1	1										
48	62415	Bouchon filtre de remplissage Tapón filtro de llenado Tappo filtro di riempimento	- Einfullfilterverschluss - Filling plug filter -							1	1	1	1										
49	1071	Joint d'étanchéité Junta de estanqueidad Guarnizióne	- Dichtungsring - Seal -							1	1	1	1										
50	62845	Filtre Filtro Filtro	- Filter - Filter -							1	1	1	1										
51	247581	Raccord Racor Raccordo	- Verschraubung - Connection -							1	1	1	1										
52	248406	Raccord Coudé Cranté Racor Raccordo	- Verschraubung - Connection -							1	1	1	1										
53	190019	Joint torique Junta tórica Anello OR	- "O" ring - "O" ring -							X	X	X	X										
54	252073	Durit (Lg 200) Tubo flexible Manicotto	- Schlauch - Hose -							1	1	1	1										
55	71940	Collier Abrazadera Fascetta	- Spannschelle - Clamp -							2	2	2	2										

Catalogue : 647000

6

HYDRAULIQUE (Circuit principal)  
 HYDRAULIK (Hauptkreis)  
 HIDRAULICO (Circuito principal)  
 HYDRAULIC (Principal circuit)  
 IDRAULICO (Circuito principale)

Qté-Menge-Cant-Qty-Q.ta

10 AA

742

M

1-	MH20-4T	BUG. S2-E3	11-
2-	MH25-4T	BUG. S2-E3	12-
3-	MSI 20T	S2-E3	13-
4-	MSI 20T	BUG. S2-E3	14-
5-	MSI 25T	S2-E3	15-
6-	MSI 25T	BUG. S2-E3	16-
7-	MSI 30T	S2-E3	17-
8-	MSI 30T	BUG. S2-E3	18-
9-	MSI 35T	S2-E3	19-
10-	MSI 35T	BUG. S2-E3	20-

Rep Hinw Fig Item Rif	Numéro Teil-Nr Numero Part-Nr Part-Nr	Désignation Bezeichnung Descripcion Description Descrizione	1	2	3	4	5	6	7	8	9	10	11	12	13	14	15	16	17	18	19	20
56	232790	Raccord Union Cranté Racor Raccordo							1	1	1	1										
57	169372	Joint torique Junta torica Anello OR							X	X	X	X										
58	5804	Vis H,M10- 25-8.8-ZN8/C Tornillo Vite							1	1	1	1										
59	703042	Pochette de joints Juego de juntas Kit guarnizióni							1	1	1	1										
60	563486	Valve Válvula Valvola							1	1	1	1										
61	604583	Pochette de joints (Valve) Juego de juntas (Válvula) Kit guarnizióne (Valvola)							1	1	1	1										
62	25714	Ecrou H ,M 6 ZN Tuerca Dado							1	1	1	1										
63	215632	Raccord Coudé 90° Adapteur Racor Raccordo							1	1	1	1										
64	190874	Joint torique Junta tórica Anello OR							X	X	X	X										
65	250108	Flexible (Lg 620) Flexible Flessibile							1	1	1	1										
66	250105	Raccord Coudé Racor Raccordo							1	1	1	1										

+

Catalogue : 647000

7

HYDRAULIQUE (Circuit principal)  
 HYDRAULIK (Hauptkreis)  
 HIDRAULICO (Circuito principal)  
 HYDRAULIC (Principal circuit)  
 IDRAULICO (Circuito principale)

Qté-Menge-Cant-Qty-Q.ta

10 AA

742

M

1-	MH20-4T	BUG. S2-E3	11-
2-	MH25-4T	BUG. S2-E3	12-
3-	MSI 20T	S2-E3	13-
4-	MSI 20T	BUG. S2-E3	14-
5-	MSI 25T	S2-E3	15-
6-	MSI 25T	BUG. S2-E3	16-
7-	MSI 30T	S2-E3	17-
8-	MSI 30T	BUG. S2-E3	18-
9-	MSI 35T	S2-E3	19-
10-	MSI 35T	BUG. S2-E3	20-

Rep Hinw Fig Item Rif	Numéro Teil-Nr Numero Part-Nr Part-Nr	Désignation Bezeichnung Descripcion Description Descrizione	1	2	3	4	5	6	7	8	9	10	11	12	13	14	15	16	17	18	19	20	
67	214079	Valve Válvula Valvola - Ventil - Valve -							1	1	1	1											
68	561630	Pochette de joints Juego de juntas Kit guarnizióni - Dichtungssatz - Seal kit -							X	X	X	X											
69	58531	Vis H,M 8- 50-8.8-ZN8/C Tornillo Vite - Schraube - Screw -							2	2	2	2											
70	61674	Rondelle M 8 ZN Arandela Rondella - Unterlegscheibe - Washer -							2	2	2	2											
71	250104	Raccord Coudé Racor Raccordo - Verschraubung - Connection -							1	1	1	1											
72	250107	Flexible (Lg 300) Flexible Flessibile - Schlauch - Hose -							1	1	1	1											
73	173038	Raccord Union Racor Raccordo - Verschraubung - Connection -							1	1	1	1											

# 10 AB 63

HYDRAULIQUE (Circuit inclinaison - Elévation)  
 HYDRAULIK (Neigung - Aufwinden kreis)  
 HIDRAULICO (Circuito inclinación - Elevación)  
 HYDRAULIC (Tilting -Lifting circuit)  
 IDRAULICO (Circuito inclinazione - Sollevamento)

MH 20-4 T BUGGIE S2-E3  
 MH 25-4 T BUGGIE S2-E3  
 MSI 20 / 25 / 30 / 35 T S2-E3  
 MSI 20 / 25 / 30 / 35 T BUGGIE S2-E3

POUR FLEXIBLE ET RACCORD  
 FÜR SCHLAUCH UND VERSCHRAUBUNG  
 PARA FLEXIBLE Y RACOR  
 FOR HOSE AND CONNECTION  
 PER FLESSIBILE E RACCORDO

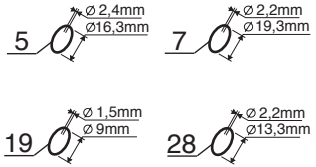

POUR MACHINE AVEC MAT INFÉRIEUR A 6 M  
 FÜR MASCHINE MIT MAST MIEDRIGER ALS 6 M  
 PARA MAQUINA CON MASTIL INFERIOR A 6 M  
 FOR MACHINE WITH MAST LOWER THAN 6 M  
 PER MACCHINA CON RAMPA INFERIORE A 6 M

SUIVANT MONTAGE  
 NACH MONTAGE  
 SEGUN MONTAJE  
 AS MOUNTING  
 SECONDO MONTAGGIO

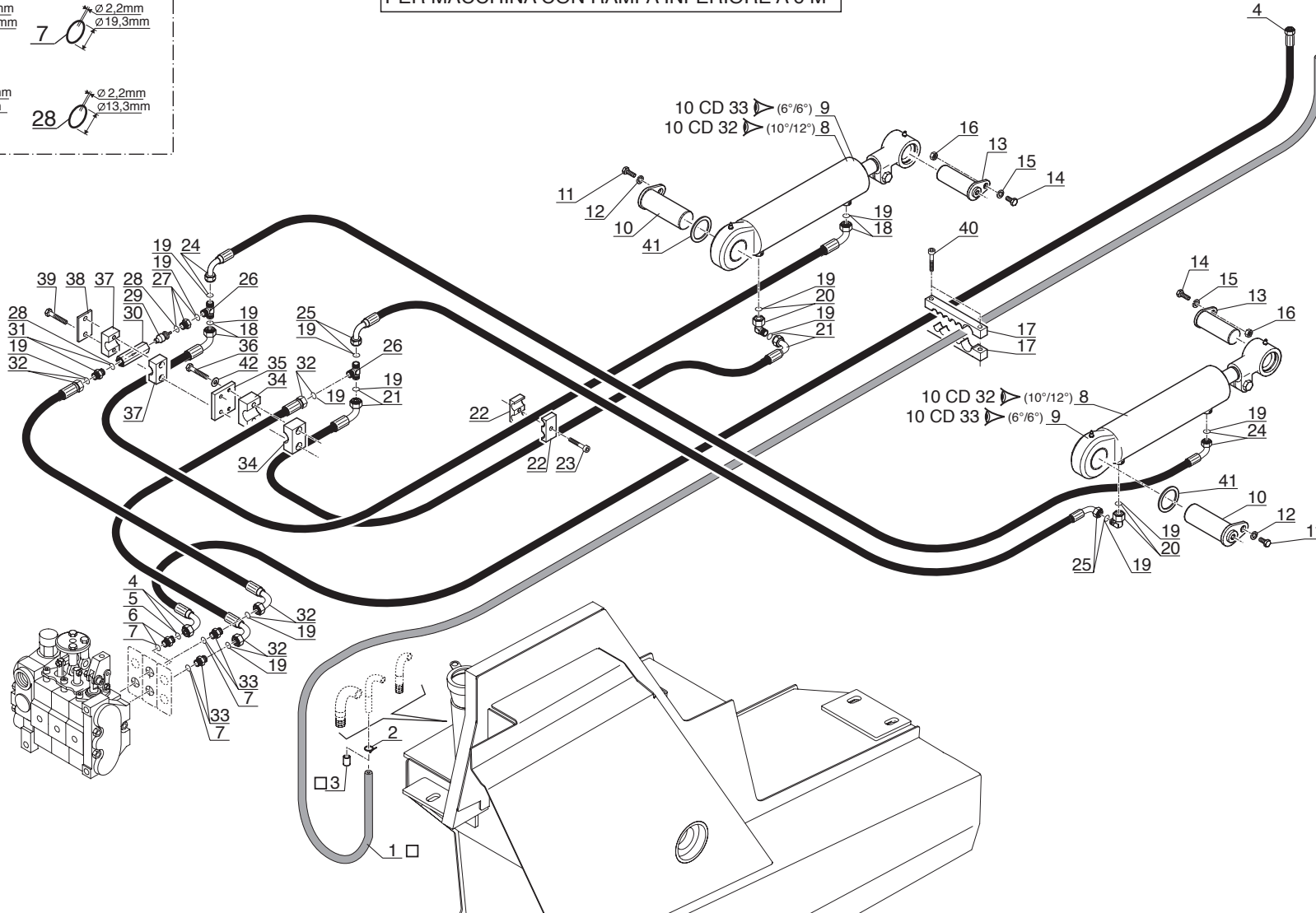

Catalogue : 647000

1	HYDRAULIQUE (Circuit Inclinaison - Elévation) HYDRAULIK (Neigung - Aufwinden kreis) HIDRAULICO (Circuito Inclinação - Elevación) HYDRAULIC (Tilting - Lifting circuit) IDRAULICO (Circuito Inclinazione - Sollevamento)			Qté-Menge-Cant-Qty-Q.ta										10 AB		63		M					
	Rep Hinw Fig Item Rif	Número Teil-Nr Numero Part-Nr Part-Nr	Désignation Bezeichnung Descripcion Description Descrizione	1	2	3	4	5	6	7	8	9	10	11	12	13	14	15	16	17	18	19	20
1	218652	Durit (Lg 2150) Tubo flexible Manicotto	- Schlauch - Hose -	1	1	1	1	1	1	1	1	1	1										
2	211071	Collier Abrazadera Fascetta	- Spannschelle - Clamp -	1	1	1	1	1	1	1	1	1	1										
3	211106	Capuchon Capuchón Cappuccio	- Kappe - Cap -	1	1	1	1	1	1	1	1	1	1										
4	216056	Flexible Flexible Flessibile	- Schlauch - Hose -	1	1	1	1	1	1	1	1	1	1										
5	86788	Joint torique Junta tórica Anello OR	- "0" ring - "0" ring -	X	X	X	X	X	X	X	X	X	X										
6	167923	Raccord Union Racor Raccordo	- Verschraubung - Connection -	1	1	1	1	1	1	1	1	1	1										
7	169373	Joint torique Junta tórica Anello OR	- "0" ring - "0" ring -	X	X	X	X	X	X	X	X	X	X										
8	208574	Vérin inclinai. D:30mm C:161mm Cilindro de inclinación Cilindro di inclinazione	- Neigungszylinder - Tilting cylinder -	2	2	2	2	2	2	2	2	2	2										
9	208575	Vérin inclinai. D:30mm C: 87mm Cilindro de inclinación Cilindro di inclinazione	- Neigungszylinder - Tilting cylinder -	2	2	2	2	2	2	2	2	2	2										
10	215675	Axe d'articulation Eje de articulaci6n Perno di articolazione	- Gelenkachse - Articulating pin -	2	2	2	2	2	2	2	2	2	2										
11	252164	Vis H,M10- 20-8.8-ZN8/C SPEC Tornillo Vite	- Schraube - Screw -	2	2	2	2	2	2	2	2	2	2										

Catalogue : 647000

2

HYDRAULIQUE (Circuit Inclinaison - Elévation)  
 HYDRAULIK (Neigung - Aufwinden kreis)  
 HIDRAULICO (Circuito Inclinación - Elevación)  
 HYDRAULIC (Tilting - Lifting circuit)  
 IDRAULICO (Circuito Inclinazone - Sollevamento)

Qté-Menge-Cant-Qty-Q.ta

10 AB

63

M

1-	MH20-4T	BUG. S2-E3	11-
2-	MH25-4T	BUG. S2-E3	12-
3-	MSI 20T	S2-E3	13-
4-	MSI 20T	BUG. S2-E3	14-
5-	MSI 25T	S2-E3	15-
6-	MSI 25T	BUG. S2-E3	16-
7-	MSI 30T	S2-E3	17-
8-	MSI 30T	BUG. S2-E3	18-
9-	MSI 35T	S2-E3	19-
10-	MSI 35T	BUG. S2-E3	20-

Rep Hinw Fig Item Rif	Numéro Teil-Nr Numero Part-Nr Part-Nr	Désignation Bezeichnung Descripcion Description Descrizione	1	2	3	4	5	6	7	8	9	10	11	12	13	14	15	16	17	18	19	20
12	42232	Rondelle W10 ZN Arandela Rondella - Unterlegscheibe - Washer -	2	2	2	2	2	2	2	2	2	2										
13	216150	Axe d'articulation Eje de articulación Perno di articolazione - Gelenkachse - Articulating pin -	2	2	2	2	2	2	2	2	2	2										
14	58535	Vis H,M10- 40-8.8-ZN8/C Tornillo Vite - Schraube - Screw -	2	2	2	2	2	2	2	2	2	2										
15	42232	Rondelle W10 ZN Arandela Rondella - Unterlegscheibe - Washer -	2	2	2	2	2	2	2	2	2	2										
16	56354	Ecrou H ,M10 zingué Tuerca Dado - Mutter - Nut -	2	2	2	2	2	2	2	2	2	2										
17	211286	Bride Flangia Flangia - Brida - Flange -	2	2	2	2	2	2	2	2	2	2										
18	202154	Flexible Flexible Flessibile - Schlauch - Hose -	1	1	1	1	1	1	1	1	1	1										
19	190874	Joint torique Junta tórica Anello OR - "0" ring - "0" ring -	X	X	X	X	X	X	X	X	X	X										
20	197233	Raccord Coudé 90° Adapteur Racor Raccordo - Verschraubung - Connection -	2	2	2	2	2	2	2	2	2	2										
21	208577	Flexible Flexible Flessibile - Schlauch - Hose -	1	1	1	1	1	1	1	1	1	1										
22	168758	Demi-collier Media abrazadera Fascetta - Halb-klemme - Half-clamp -	2	2	2	2	2	2	2	2	2	2										

+

Catalogue : 647000

3

HYDRAULIQUE (Circuit Inclinaison - Elévation)  
 HYDRAULIK (Neigung - Aufwinden kreis)  
 HIDRAULICO (Circuito Inclinação - Elevación)  
 HYDRAULIC (Tilting - Lifting circuit)  
 IDRAULICO (Circuito Inclinazione - Sollevamento)

Qté-Menge-Cant-Qty-Q.ta

10 AB

63

M

1-	MH20-4T	BUG. S2-E3	11-
2-	MH25-4T	BUG. S2-E3	12-
3-	MSI 20T	S2-E3	13-
4-	MSI 20T	BUG. S2-E3	14-
5-	MSI 25T	S2-E3	15-
6-	MSI 25T	BUG. S2-E3	16-
7-	MSI 30T	S2-E3	17-
8-	MSI 30T	BUG. S2-E3	18-
9-	MSI 35T	S2-E3	19-
10-	MSI 35T	BUG. S2-E3	20-

Rep Hinw Fig Item Rif	Numéro Teil-Nr Numero Part-Nr Part-Nr	Désignation Bezeichnung Descripcion Description Descrizione	1	2	3	4	5	6	7	8	9	10	11	12	13	14	15	16	17	18	19	20	
23	18805	Vis CHc,M 8- 25 zinguée Tornillo Vite - Schraube - Screw -	1	1	1	1	1	1	1	1	1	1											
24	247677	Flexible (Lg 395) Flexible Flessibile - Schlauch - Hose -	1	1	1	1	1	1	1	1	1	1											
25	278928	Flexible (Lg 320) Flexible Flessibile - Schlauch - Hose -	1	1	1	1	1	1	1	1	1	1											
26	168735	Raccord Té Adapteur Racor Raccordo - Verschraubung - Connection -	2	2	2	2	2	2	2	2	2	2											
27	169091	Raccord Adapteur Racor Raccordo - Verschraubung - Connection -	1	1	1	1	1	1	1	1	1	1											
28	169436	Joint torique Junta tórica Anello OR - "0" ring - "0" ring -	X	X	X	X	X	X	X	X	X	X											
29	164075	Ralentisseur de débit Válvula de restricción Regolatore di flusso - Druckregler - Flow restrictor -	1	1	1	1	1	1	1	1	1	1											
30	174231	Corps de ralentisseur Cuerpo de válvula de restricción Flow restrictor body Corpo di regolatore - Druckregler körper -	1	1	1	1	1	1	1	1	1	1											
31	167927	Raccord Union Racor Raccordo - Verschraubung - Connection -	1	1	1	1	1	1	1	1	1	1											
32	203409	Flexible (Lg 500) Flexible Flessibile - Schlauch - Hose -	2	2	2	2	2	2	2	2	2	2											
33	173038	Raccord Union Racor Raccordo - Verschraubung - Connection -	2	2	2	2	2	2	2	2	2	2											

+

Catalogue : 647000

4	HYDRAULIQUE (Circuit Inclinaison - Elévation) HYDRAULIK (Neigung - Aufwinden kreis) HIDRAULICO (Circuito Inclinación - Elevación) HYDRAULIC (Tilting - Lifting circuit) IDRAULICO (Circuito Inclinazone - Sollevamento)			Qté-Menge-Cant-Qty-Q.ta										10 AB		63		M					
	Rep Hinw Fig Item Rif	Numéro Teil-Nr Numero Part-Nr Part-Nr	Désignation Bezeichnung Descripcion Description Descrizione	1	2	3	4	5	6	7	8	9	10	11	12	13	14		15	16	17	18	19
34	172914	Demi-collier Media abrazadera Fascetta	- Halb-klemme - Half-clamp -	2	2	2	2	2	2	2	2	2	2										
35	242042	Support Soporte Supporto	- Träger - Bracket -	1	1	1	1	1	1	1	1	1	1										
36	29481	Vis H,M 6- 45-8.8-ZN5/C Tornillo Vite	- Schraube - Screw -	2	2	2	2	2	2	2	2	2	2										
37	168856	Demi-collier Media abrazadera Fascetta	- Halb-klemme - Half-clamp -	2	2	2	2	2	2	2	2	2	2										
38	168858	Plaque de protection Placa de protección Piastra di protezione	- Schützplatte - Protection plate -	1	1	1	1	1	1	1	1	1	1										
39	31007	Vis H,M 6- 50-8.8-ZN5/C Tornillo Vite	- Schraube - Screw -	2	2	2	2	2	2	2	2	2	2										
40	57757	Vis CHc,M 8- 45 zinguee Tornillo Vite	- Schraube - Screw -	2	2	2	2	2	2	2	2	2	2										
41	181490	Rondelle SP 46 x 68 x 1,5ZN Arandela Rondella	- Unterlegscheibe - Washer -	X	X	X	X	X	X	X	X	X	X										
41	181491	Rondelle SP 46 x 68 x 2,5ZN Arandela Rondella	- Unterlegscheibe - Washer -	X	X	X	X	X	X	X	X	X	X										
42	29469	Rondelle M 6 ZN Arandela Rondella	- Unterlegscheibe - Washer -	2	2	2	2	2	2	2	2	2	2										





# 10 AB 64

HYDRAULIQUE (Circuit inclinaison - Elévation)  
 HYDRAULIK (Neigung - Aufwinden kreis)  
 HIDRAULICO (Circuito inclinación - Elevación)  
 HYDRAULIC (Tilting -Lifting circuit)  
 IDRAULICO (Circuito inclinazione - Sollevamento)

MH 20-4 T BUGGIE S2-E3  
 MH 25-4 T BUGGIE S2-E3  
 MSI 20 / 25 / 30 / 35 T S2-E3  
 MSI 20 / 25 / 30 / 35 T BUGGIE S2-E3

POUR FLEXIBLE ET RACCORD  
 FÜR SCHLAUCH UND VERSCHRAUBUNG  
 PARA FLEXIBLE Y RACOR  
 FOR HOSE AND CONNECTION  
 PER FLESSIBILE E RACCORDO

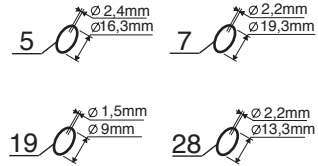

POUR MACHINE AVEC MAT EGAL OU SUPERIEUR A 6 M  
 FÜR MASCHINE MIT MAST GLEICH ODER HÖHER ALS 6 M  
 PARA MAQUINA CON MASTIL IGUAL O SUPERIOR A 6 M  
 FOR MACHINE WITH MAST EQUAL OR UPPER THAN 6 M  
 PER MACCHINA CON RAMPA UGUALE O SUPERIORE A 6 M

SUIVANT MONTAGE  
 NACH MONTAGE  
 SEGUN MONTAJE  
 AS MOUNTING  
 SECONDO MONTAGGIO

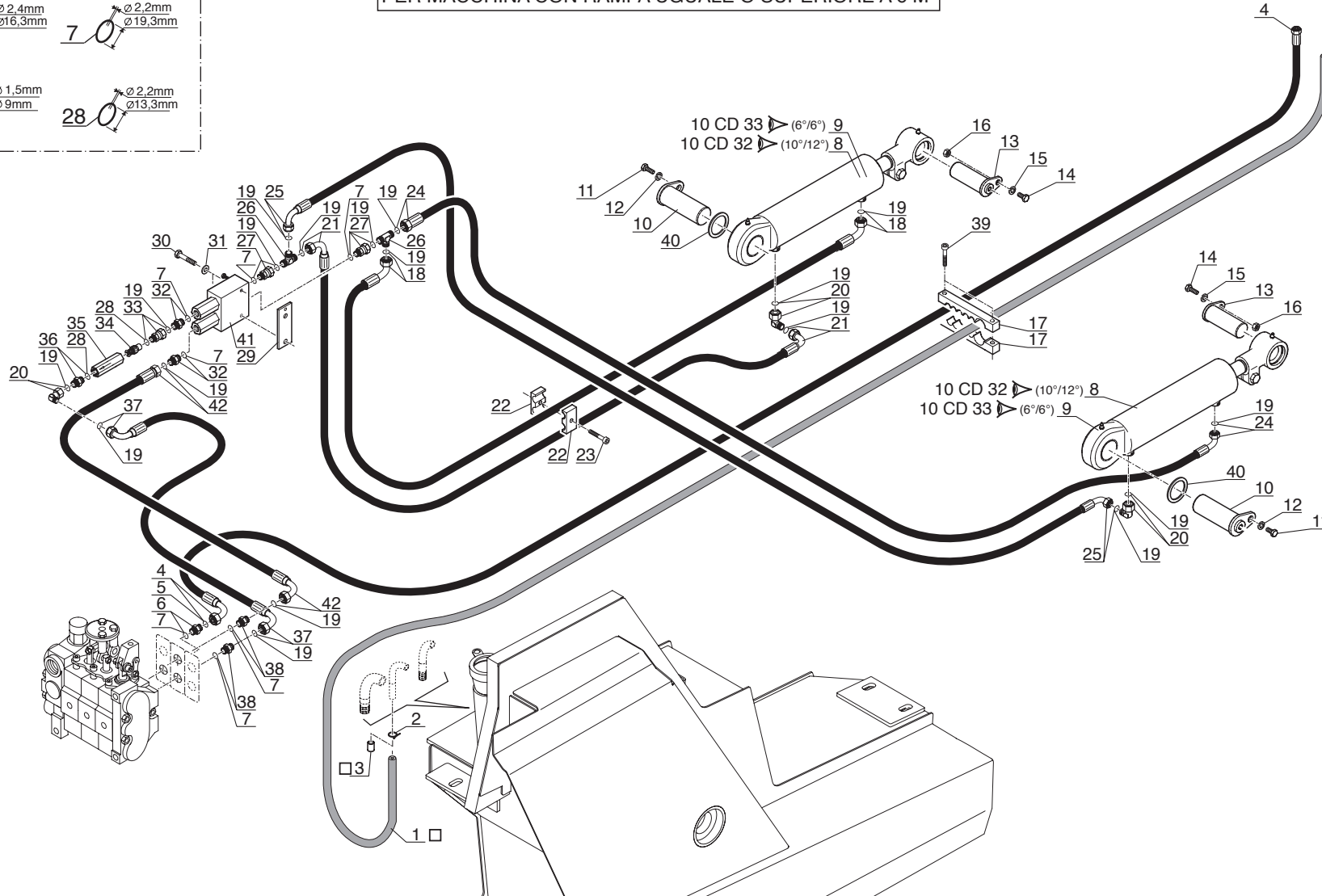

Catalogue : 647000

1	HYDRAULIQUE (Circuit Inclinaison - Elévation) HYDRAULIK (Neigung - Aufwinden kreis) HIDRAULICO (Circuito Inclinación - Elevación) HYDRAULIC (Tilting - Lifting circuit) IDRAULICO (Circuito Inclinazione - Sollevamento)			Qté-Menge-Cant-Qty-Q.ta										10 AB					64					M
	Rep Hinw Fig Item Rif	Número Teil-Nr Numero Part-Nr Part-Nr	Désignation Bezeichnung Descripcion Description Descrizione	1	2	3	4	5	6	7	8	9	10	11	12	13	14	15	16	17	18	19	20	
1	218652	Durit (Lg 2150) Tubo flexible Manicotto	- Schlauch - Hose -	1	1	1	1	1	1	1	1	1	1											
2	211071	Collier Abrazadera Fascetta	- Spannschelle - Clamp -	1	1	1	1	1	1	1	1	1	1											
3	211106	Capuchon Capuchón Cappuccio	- Kappe - Cap -	1	1	1	1	1	1	1	1	1	1											
4	216056	Flexible Flexible Flessibile	- Schlauch - Hose -	1	1	1	1	1	1	1	1	1	1											
5	86788	Joint torique Junta tórica Anello OR	- "0" ring - "0" ring -	X	X	X	X	X	X	X	X	X	X											
6	167923	Raccord Union Racor Raccordo	- Verschraubung - Connection -	1	1	1	1	1	1	1	1	1	1											
7	169373	Joint torique Junta tórica Anello OR	- "0" ring - "0" ring -	X	X	X	X	X	X	X	X	X	X											
8	208574	Vérin inclinai. D:30mm C:161mm Cilindro de inclinación Cilindro di inclinazione	- Neigungszylinder - Tilting cylinder -	2	2	2	2	2	2	2	2	2	2											
9	208575	Vérin inclinai. D:30mm C: 87mm Cilindro de inclinación Cilindro di inclinazione	- Neigungszylinder - Tilting cylinder -	2	2	2	2	2	2	2	2	2	2											
10	215675	Axe d'articulation Eje de articulaci6n Perno di articolazione	- Gelenkachse - Articulating pin -	2	2	2	2	2	2	2	2	2	2											
11	252164	Vis H,M10- 20-8.8-ZN8/C SPEC Tornillo Vite	- Schraube - Screw -	2	2	2	2	2	2	2	2	2	2											

+

Catalogue : 647000

2

HYDRAULIQUE (Circuit Inclinaison - Elévation)  
 HYDRAULIK (Neigung - Aufwinden kreis)  
 HIDRAULICO (Circuito Inclinaición - Elevación)  
 HYDRAULIC (Tilting - Lifting circuit)  
 IDRAULICO (Circuito Inclinaçione - Sollevamento)

Qté-Menge-Cant-Qty-Q.ta

10 AB

64

M

1-	MH20-4T	BUG. S2-E3	11-
2-	MH25-4T	BUG. S2-E3	12-
3-	MSI 20T	S2-E3	13-
4-	MSI 20T	BUG. S2-E3	14-
5-	MSI 25T	S2-E3	15-
6-	MSI 25T	BUG. S2-E3	16-
7-	MSI 30T	S2-E3	17-
8-	MSI 30T	BUG. S2-E3	18-
9-	MSI 35T	S2-E3	19-
10-	MSI 35T	BUG. S2-E3	20-

Rep Hinw Fig Item Rif	Numéro Teil-Nr Numero Part-Nr Part-Nr	Désignation Bezeichnung Descripcion Description Descrizione	Qté-Menge-Cant-Qty-Q.ta																			
			1	2	3	4	5	6	7	8	9	10	11	12	13	14	15	16	17	18	19	20
12	42232	Rondelle W10 ZN Arandela Rondella	-	Unterlegscheibe - Washer -	2	2	2	2	2	2	2	2	2	2								
13	216150	Axe d'articulation Eje de articulaci3n Perno di articolazione	-	Gelenkachse - Articulating pin -	2	2	2	2	2	2	2	2	2	2								
14	58535	Vis H,M10- 40-8.8-ZN8/C Tornillo Vite	-	Schraube - Screw -	2	2	2	2	2	2	2	2	2	2								
15	42232	Rondelle W10 ZN Arandela Rondella	-	Unterlegscheibe - Washer -	2	2	2	2	2	2	2	2	2	2								
16	56354	Ecrou H ,M10 zingué Tuerca Dado	-	Mutter - Nut -	2	2	2	2	2	2	2	2	2	2								
17	211286	Bride Flangia Flangia	-	Brida - Flange -	2	2	2	2	2	2	2	2	2	2								
18	202154	Flexible Flexible Flessibile	-	Schlauch - Hose -	1	1	1	1	1	1	1	1	1	1								
19	190874	Joint torique Junta t3rica Anello OR	-	"0" ring - "0" ring -	X	X	X	X	X	X	X	X	X	X								
20	197233	Raccord Coudé 90° Adapteur Racor Raccordo	-	Verschraubung - Connection -	3	3	3	3	3	3	3	3	3	3								
21	221737	Flexible (Lg 1600) Flexible Flessibile	-	Schlauch - Hose -	1	1	1	1	1	1	1	1	1	1								
22	168758	Demi-collier Media abrazadera Fascetta	-	Halb-klemme - Half-clamp -	2	2	2	2	2	2	2	2	2	2								

+

Catalogue : 647000

3	HYDRAULIQUE (Circuit Inclinaison - Elévation) HYDRAULIK (Neigung - Aufwinden kreis) HIDRAULICO (Circuito Inclinação - Elevación) HYDRAULIC (Tilting - Lifting circuit) IDRAULICO (Circuito Inclinazione - Sollevamento)			Qté-Menge-Cant-Qty-Q.ta										10 AB					64					M
	Rep Hinw Fig Item Rif	Numéro Teil-Nr Numero Part-Nr Part-Nr	Désignation Bezeichnung Descripcion Description Descrizione	1	2	3	4	5	6	7	8	9	10	11	12	13	14	15	16	17	18	19	20	
23	18805	Vis CHc,M 8- 25 zinguée Tornillo Vite	- Schraube - Screw -	1	1	1	1	1	1	1	1	1	1											
24	213031	Flexible (Lg 550) Flexible Flessibile	- Schlauch - Hose -	1	1	1	1	1	1	1	1	1	1											
25	278928	Flexible (Lg 320) Flexible Flessibile	- Schlauch - Hose -	1	1	1	1	1	1	1	1	1	1											
26	168735	Raccord Té Adapteur Racor Raccordo	- Verschraubung - Connection -	2	2	2	2	2	2	2	2	2	2											
27	167932	Raccord Adapteur Racor Raccordo	- Verschraubung - Connection -	2	2	2	2	2	2	2	2	2	2											
28	169436	Joint torique Junta tórica Anello OR	- "0" ring - "0" ring -	X	X	X	X	X	X	X	X	X	X											
29	207161	Support Soporte Supporto	- Träger - Bracket -	1	1	1	1	1	1	1	1	1	1											
30	31007	Vis H,M 6- 50-8.8-ZN5/C Tornillo Vite	- Schraube - Screw -	2	2	2	2	2	2	2	2	2	2											
31	29469	Rondelle M 6 ZN Arandela Rondella	- Unterlegscheibe - Washer -	2	2	2	2	2	2	2	2	2	2											
32	173038	Raccord Union Racor Raccordo	- Verschraubung - Connection -	2	2	2	2	2	2	2	2	2	2											
33	169091	Raccord Adapteur Racor Raccordo	- Verschraubung - Connection -	1	1	1	1	1	1	1	1	1	1											

+

Catalogue : 647000

4	HYDRAULIQUE (Circuit Inclinaison - Elévation) HYDRAULIK (Neigung - Aufwinden kreis) HIDRAULICO (Circuito Inclinação - Elevación) HYDRAULIC (Tilting - Lifting circuit) IDRAULICO (Circuito Inclinazione - Sollevamento)			Qté-Menge-Cant-Qty-Q.ta										10 AB		64		M					
	Rep Hinw Fig Item Rif	Numéro Teil-Nr Numero Part-Nr Part-Nr	Désignation Bezeichnung Descripcion Description Descrizione	1	2	3	4	5	6	7	8	9	10	11	12	13	14	15	16	17	18	19	20
34	164075	Ralentisseur de débit Válvula de restricción Regolatore di flusso	- Druckregler - Flow restrictor -	1	1	1	1	1	1	1	1	1	1										
35	174231	Corps de ralentisseur Cuerpo de válvula de restricción Flow restrictor body Corpo di regolatore	- Druckregler körper -	1	1	1	1	1	1	1	1	1	1										
36	167927	Raccord Union Racor Raccordo	- Verschraubung - Connection -	1	1	1	1	1	1	1	1	1	1										
37	208578	Flexible Flexible Flessibile	- Schlauch - Hose -	1	1	1	1	1	1	1	1	1	1										
38	173038	Raccord Union Racor Raccordo	- Verschraubung - Connection -	2	2	2	2	2	2	2	2	2	2										
39	57757	Vis CHc,M 8- 45 zinguee Tornillo Vite	- Schraube - Screw -	2	2	2	2	2	2	2	2	2	2										
40	181490	Rondelle SP 46 x 68 x 1,5ZN Arandela Rondella	- Unterlegscheibe - Washer -	X	X	X	X	X	X	X	X	X	X										
40	181491	Rondelle SP 46 x 68 x 2,5ZN Arandela Rondella	- Unterlegscheibe - Washer -	X	X	X	X	X	X	X	X	X	X										
41	169311	Valve d'équilibrage Válvula de equilibrado Valvola di equilibratura	- Abgleichen ventil - Balancing valve -	1	1	1	1	1	1	1	1	1	1										
42	203409	Flexible (Lg 500) Flexible Flessibile	- Schlauch - Hose -	1	1	1	1	1	1	1	1	1	1										



10 AJ 12

HYDRAULIQUE (Circuit levage cabine)  
HYDRAULIK (Kabine aufwinden kreis)  
HIDRAULICO (Circuito levantamiento cabina)  
HYDRAULIC (Cab lifting circuit)  
IDRAULICO (Circuito sollevamento cabina)

MH 20-4 T BUGGIE S2-E3  
MH 25-4 T BUGGIE S2-E3  
MSI 20 / 25 / 30 / 35 T S2-E3  
MSI 20 / 25 / 30 / 35 T BUGGIE S2-E3

POUR FLEXIBLE ET RACCORD  
FÜR SCHLAUCH UND VERSCHRAUBUNG  
PARA FLEXIBLE Y RACOR  
FOR HOSE AND CONNECTION  
PER FLESSIBILE E RACCORDO

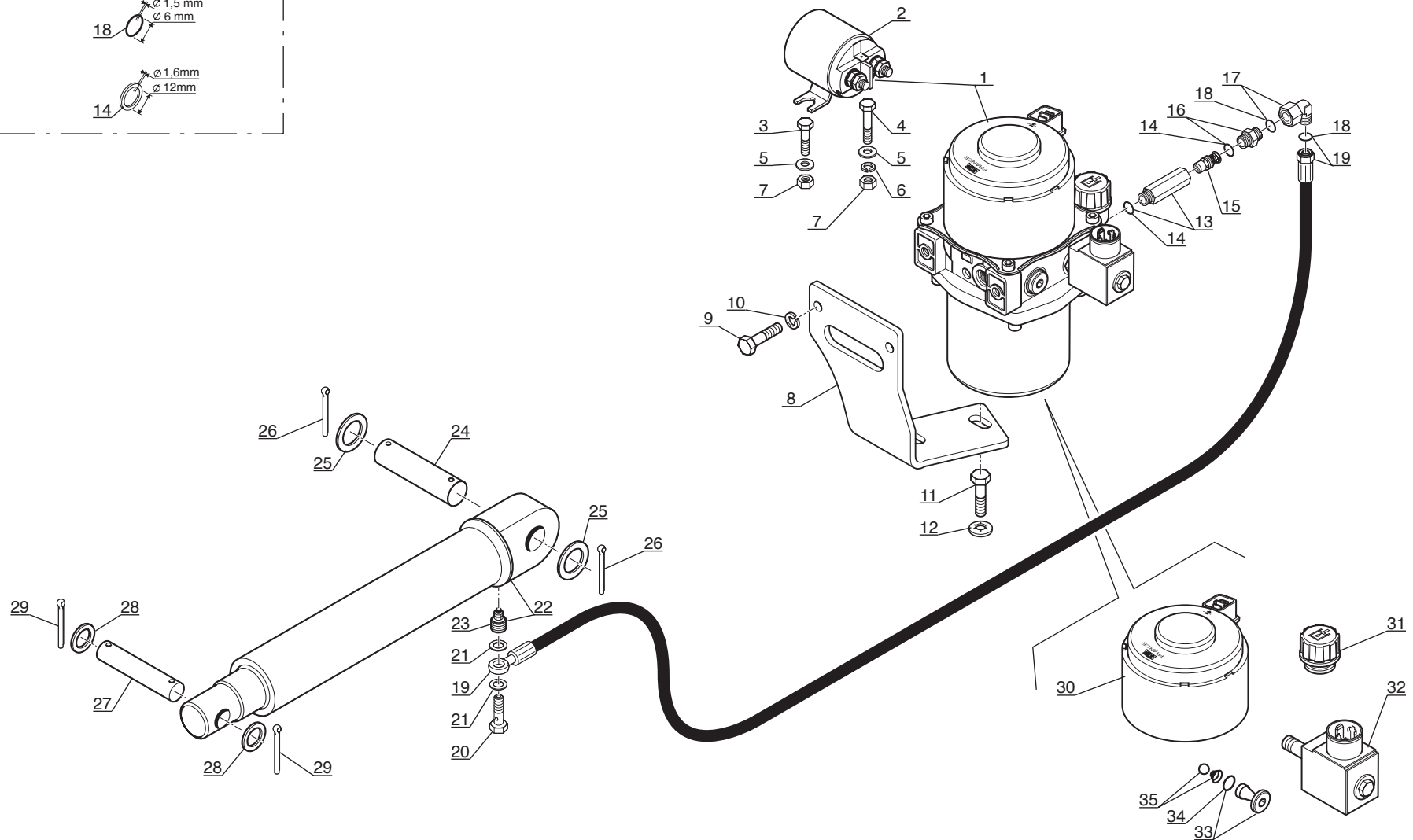
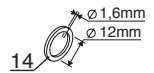
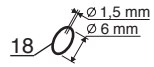



Catalogue : 647000

1	HYDRAULIQUE (Circuit levage cabine) HYDRAULIK (Kabine aufwinden kreis) HIDRAULICO (Circuito levantamiento cabina) HYDRAULIC (Cab lifting circuit) IDRAULICO (Circuito sollevamento cabina)			Qté-Menge-Cant-Qty-Q.ta										10 AJ					12					M
	Rep Hinw Fig Item Rif	Numéro Teil-Nr Numero Part-Nr Part-Nr	Désignation Bezeichnung Descripcion Description Descrizione	1	2	3	4	5	6	7	8	9	10	11	12	13	14	15	16	17	18	19	20	
1	245718	Pompe relevage cabine Bomba levantamiento cabina Pompa sollevamento cabina	- Aufwinder kreis pumpe - Cab lifting pump -	1	1	1	1	1	1	1	1	1	1	1										
2	211012	Relais levage cabine Relé levantamiento cabina Centralina rele sollevamento cabina	- Relais Cab lifting - Cab lifting relay -	1	1	1	1	1	1	1	1	1	1											
3	42347	Vis H,M 8- 20-8.8-ZN8/C Tornillo Vite	- Schraube - Screw -	1	1	1	1	1	1	1	1	1	1											
4	57446	Vis H,M 8- 25-8.8-ZN8/C Tornillo Vite	- Schraube - Screw -	1	1	1	1	1	1	1	1	1	1											
5	61674	Rondelle M 8 ZN Arandela Rondella	- Unterlegscheibe - Washer -	2	2	2	2	2	2	2	2	2	2											
6	42325	Rondelle W 8 ZN Arandela Rondella	- Unterlegscheibe - Washer -	1	1	1	1	1	1	1	1	1	1											
7	58528	Ecrou H ,M 8 ZN Tuerca Dado	- Mutter - Nut -	2	2	2	2	2	2	2	2	2	2											
8	247568	Support Soporte Supporto	- Träger - Bracket -	1	1	1	1	1	1	1	1	1	1											
9	42347	Vis H,M 8- 20-8.8-ZN8/C Tornillo Vite	- Schraube - Screw -	2	2	2	2	2	2	2	2	2	2											
10	42325	Rondelle W 8 ZN Arandela Rondella	- Unterlegscheibe - Washer -	2	2	2	2	2	2	2	2	2	2											
11	63727	Vis Tornillo Vite	- Schraube - Screw -	2	2	2	2	2	2	2	2	2	2											

Catalogue : 647000

2	HYDRAULIQUE (Circuit levage cabine) HYDRAULIK (Kabine aufwinden kreis) HIDRAULICO (Circuito levantamiento cabina) HYDRAULIC (Cab lifting circuit) IDRAULICO (Circuito sollevamento cabina)			Qté-Menge-Cant-Qty-Q.ta							10 AJ					12					M		
	Rep Hinw Fig Item Rif	Numéro Teil-Nr Numero Part-Nr Part-Nr	Désignation Bezeichnung Descripcion Description Descrizione	1	2	3	4	5	6	7	8	9	10	11	12	13	14	15	16	17		18	19
				1- MH20-4T BUG. S2-E3	11-																		
				2- MH25-4T BUG. S2-E3	12-																		
				3- MSI 20T S2-E3	13-																		
				4- MSI 20T BUG. S2-E3	14-																		
				5- MSI 25T S2-E3	15-																		
				6- MSI 25T BUG. S2-E3	16-																		
				7- MSI 30T S2-E3	17-																		
				8- MSI 30T BUG. S2-E3	18-																		
				9- MSI 35T S2-E3	19-																		
				10- MSI 35T BUG. S2-E3	20-																		
12	183026	Rondelle JZC10 10,2x26 x1,4CAD.BICH Unterlegscheibe Arandela - Washer Rondella -	2	2	2	2	2	2	2	2	2	2	2										
13	198090	Raccord Union - Verschraubung Racor - Connection Raccordo -	1	1	1	1	1	1	1	1	1	1	1										
14	177636	Joint d'étanchéité - Dichtungsring Junta de estanqueidad - Seal Guarnizióne di tenuta -	X	X	X	X	X	X	X	X	X	X	X										
15	197745	Ralentisseur de débit - Druckregler Válvula de restricción - Flow restrictor Regolatore di flusso -	1	1	1	1	1	1	1	1	1	1	1										
16	191197	Raccord Union - Verschraubung Racor - Connection Raccordo -	1	1	1	1	1	1	1	1	1	1	1										
17	497922	Raccord Coudé 90° Adapteur - Verschraubung Racor - Connection Raccordo -	1	1	1	1	1	1	1	1	1	1	1										
18	190013	Joint torique - "O" ring Junta tórica - "O" ring Anello OR -	X	X	X	X	X	X	X	X	X	X	X										
19	259980	Flexible (Lg 320) - Schlauch Flexible - Hose Flessibile -	1	1	1	1	1	1	1	1	1	1	1										
20	498411	Vis creuse - Hohl schraube Tornillo hueco - Hollow screw Vite cava -	1	1	1	1	1	1	1	1	1	1	1										
21	207794	Joint cuivre - Kupferdichtung Junta cobre - Copper seal Guarnizióne rame -	2	2	2	2	2	2	2	2	2	2	2										
22	214013	Vérin levage D:35mm C: 192mm - Aufwinden zylinder Cilindro de levantamiento - Lifting cylinder Cilindro di sollevamento -	1	1	1	1	1	1	1	1	1	1	1										

+

Catalogue : 647000

3	HYDRAULIQUE (Circuit levage cabine) HYDRAULIK (Kabine aufwinden kreis) HIDRAULICO (Circuito levantamiento cabina) HYDRAULIC (Cab lifting circuit) IDRAULICO (Circuito sollevamento cabina)			Qté-Menge-Cant-Qty-Q.ta							10 AJ					12					M		
	Rep Hinw Fig Item Rif	Numéro Teil-Nr Numero Part-Nr Part-Nr	Désignation Bezeichnung Descripcion Description Descrizione	1	2	3	4	5	6	7	8	9	10	11	12	13	14	15	16	17		18	19
23	561097	Clapet Válvula Valvola	- Klappe - Valve -	1	1	1	1	1	1	1	1	1	1										
24	216080	Axe Eje Perno	- Bolzen - Pin -	1	1	1	1	1	1	1	1	1	1										
25	196460	Rondelle Z20 ZN 160HV Arandela Rondella	- Unterlegscheibe - Washer -	2	2	2	2	2	2	2	2	2	2										
26	56355	Goupille V 4 x 35 zinguée Pasador Spina	- Stift - Pin -	2	2	2	2	2	2	2	2	2	2										
27	216079	Axe Eje Perno	- Bolzen - Pin -	1	1	1	1	1	1	1	1	1	1										
28	195015	Rondelle Z16 ZN Arandela Rondella	- Unterlegscheibe - Washer -	2	2	2	2	2	2	2	2	2	2										
29	56355	Goupille V 4 x 35 zinguée Pasador Spina	- Stift - Pin -	2	2	2	2	2	2	2	2	2	2										
30	702231	Moteur électrique Motor electrico Motori elettrici	- Elektromotoren - Electric motor -	1	1	1	1	1	1	1	1	1	1										
31	476842	Bouchon de remplissage Tapón de llenado Tappo di riempimento	- Einfüllverschluss - Filling plug -	1	1	1	1	1	1	1	1	1	1										
32	476843	Solénoïde Solenoid Solenoid	- Solenoid - Solenoid -	1	1	1	1	1	1	1	1	1	1										
33	703350	Bouchon Tapón Tappo	- Stopfen - Plug -	1	1	1	1	1	1	1	1	1	1										

+

**Catalogue : 647000**

4	HYDRAULIQUE (Circuit levage cabine) HYDRAULIK (Kabine aufwinden kreis) HIDRAULICO (Circuito levantamiento cabina) HYDRAULIC (Cab lifting circuit) IDRAULICO (Circuito sollevamento cabina)			Qté-Menge-Cant-Qty-Q.ta										10 AJ	12	M							
	Rep Hinw Fig Item Rif	Numéro Teil-Nr Numero Part-Nr Part-Nr	Désignation Bezeichnung Descripcion Description Descrizione	1	2	3	4	5	6	7	8	9	10	11	12	13	14	15	16	17	18	19	20
34	476846	Joint torique Junta tórica Anello OR	- "0" ring - "0" ring -	1	1	1	1	1	1	1	1	1	1										
35	476844	Clapet anti-retour Válvula antiretorno Valvola anti-ritorno	- Gegendruckventil - Back pressure valve -	1	1	1	1	1	1	1	1	1	1										



# 10 BA 342

HYDRAULIQUE (Circuit direction)  
 HYDRAULIK (Lenkungskreis)  
 HIDRAULICO (Circuito direccion)  
 HYDRAULIC (Steering circuit)  
 IDRAULICO (Circuito sterzo)

MH 20-4 T BUGGIE S2-E3  
 MH 25-4 T BUGGIE S2-E3  
 MSI 20 / 25 / 30 / 35 T S2-E3  
 MSI 20 / 25 / 30 / 35 T BUGGIE S2-E3

POUR FLEXIBLE ET RACCORD  
 FÜR SCHLAUCH UND VERSCHRAUBUNG  
 PARA FLEXIBLE Y RACOR  
 FOR HOSE AND CONNECTION  
 PER FLESSIBILE E RACCORDO

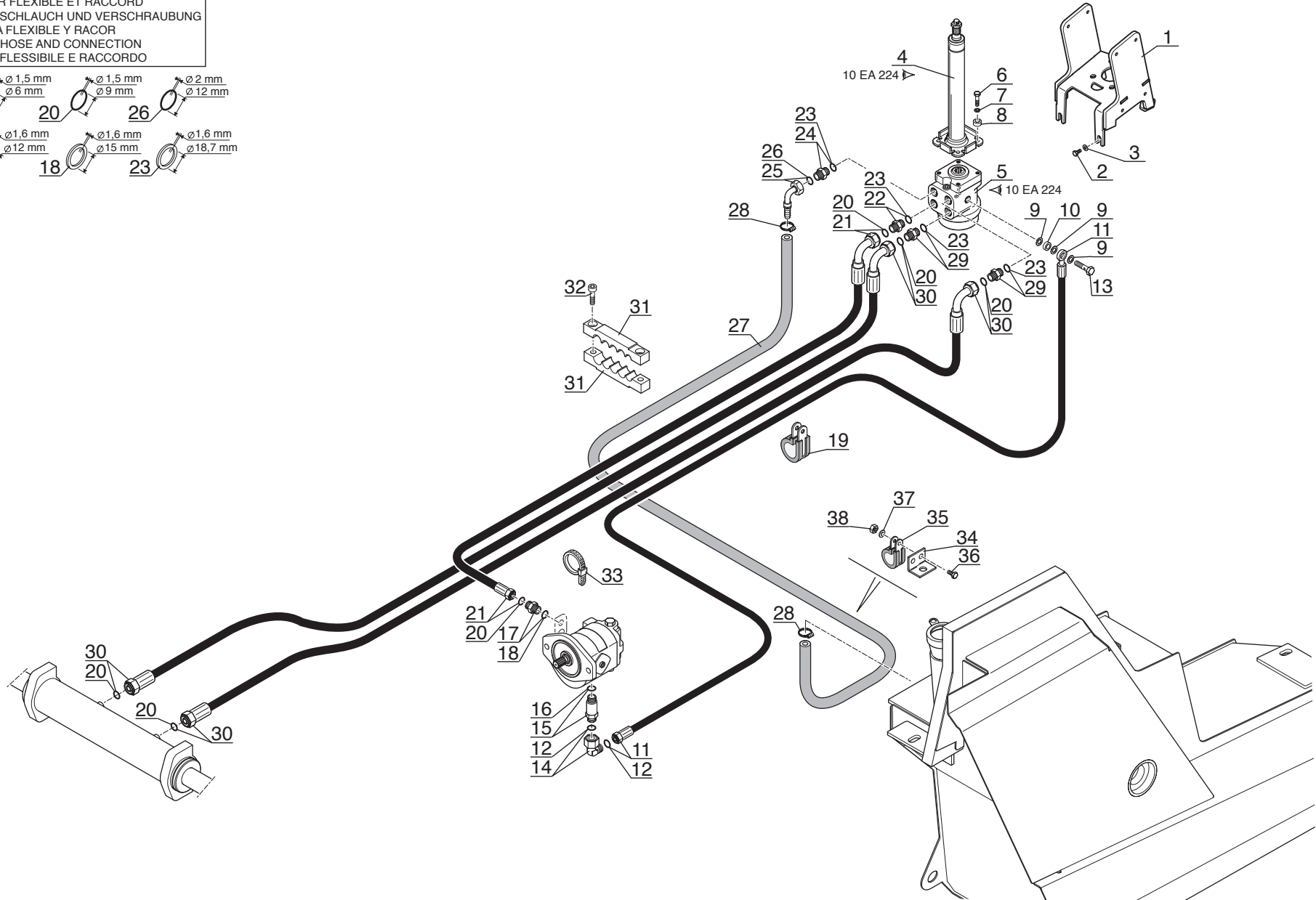
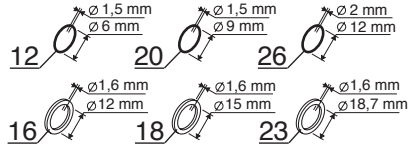

Catalogue : 647000

1	HYDRAULIQUE (Circuit direction) HYDRAULIK (Lenkungkreis) HIDRAULICO (Circuito direcci3n) HYDRAULIC (Steering circuit) IDRAULICO (Circuito sterzo)			Qt3-Menge-Cant-Qty-Q.ta							10 BA		342		M								
	Rep Hinw Fig Item Rif	Num3ro Teil-Nr Numero Part-Nr Part-Nr	D3signation Bezeichnung Description Descrizione	1	2	3	4	5	6	7	8	9	10	11	12	13	14	15	16	17	18	19	20
1	216000	Support colonne de direction Soporte columna de direcci3n Supporto colonna sterzo	- Lenksa3le tr3ger - Steering column bracket -	1	1	1	1	1	1	1	1	1	1										
2	42347	Vis H,M 8- 20-8.8-ZN8/C Tornillo Vite	- Schraube - Screw -	4	4	4	4	4	4	4	4	4	4										
3	29468	Rondelle L 8 ZN12C/FE Arandela Rondella	- Unterlegscheibe - Washer -	4	4	4	4	4	4	4	4	4	4										
4	30327	Colonne de direction Columna de direcci3n Colonna sterzo	- Lenksa3le - Steering column -	1	1	1	1	1	1	1	1	1	1										
5	208583	Corps de pompe de direction Cuerpo de bomba de direcci3n Corpo di pompa di sterzo	- Lenkung pumpe k3rper - Steering pump body -	1	1	1	1	1	1	1	1	1	1										
6	63545	Vis H,M10- 35-8.8-ZN8/C Tornillo Vite	- Schraube - Screw -	4	4	4	4	4	4	4	4	4	4										
7	42232	Rondelle W10 ZN Arandela Rondella	- Unterlegscheibe - Washer -	4	4	4	4	4	4	4	4	4	4										
8	217413	Bague Anillo Anello	- B3chse - Bushing -	4	4	4	4	4	4	4	4	4	4										
9	479275	Joint cuivre Junta cobre Guarnizi3ne rame	- Kupferdichtung - Copper seal -	3	3	3	3	3	3	3	3	3	3										
10	207785	Entretoise Separador Distanziale	- Querstrebe - Spacer -	1	1	1	1	1	1	1	1	1	1										
11	259981	Flexible (Lg 1730) Flexible Flessibile	- Schlauch - Hose -	1	1	1	1	1	1	1	1	1	1										

Catalogue : 647000

2

HYDRAULIQUE (Circuit direction)  
 HYDRAULIK (Lenkungkreis)  
 HIDRAULICO (Circuito dirección)  
 HYDRAULIC (Steering circuit)  
 IDRAULICO (Circuito sterzo)

Qté-Menge-Cant-Qty-Q.ta

10 BA

342

M

1-	MH20-4T	BUG. S2-E3	11-
2-	MH25-4T	BUG. S2-E3	12-
3-	MSI 20T	S2-E3	13-
4-	MSI 20T	BUG. S2-E3	14-
5-	MSI 25T	S2-E3	15-
6-	MSI 25T	BUG. S2-E3	16-
7-	MSI 30T	S2-E3	17-
8-	MSI 30T	BUG. S2-E3	18-
9-	MSI 35T	S2-E3	19-
10-	MSI 35T	BUG. S2-E3	20-

Rep Hinw Fig Item Rif	Número Teil-Nr Numero Part-Nr Part-Nr	Désignation Bezeichnung Description Descrizione	1	2	3	4	5	6	7	8	9	10	11	12	13	14	15	16	17	18	19	20	
12	190013	Joint torique Junta tórica Anello OR - "0" ring - "0" ring -	X	X	X	X	X	X	X	X	X	X											
13	207784	Vis creuse Tornillo hueco Vite cava -	1	1	1	1	1	1	1	1	1	1											
14	497922	Raccord Coudé 90° Adapteur Racor Raccordo -	1	1	1	1	1	1	1	1	1	1											
15	213402	Raccord Union Prolongateur Racor Raccordo -	1	1	1	1	1	1	1	1	1	1											
16	177636	Joint d'étanchéité Junta de estanqueidad Guarnizione di tenuta -	X	X	X	X	X	X	X	X	X	X											
17	192386	Raccord Union Racor Raccordo -	1	1	1	1	1	1	1	1	1	1											
18	190877	Joint d'étanchéité Junta de estanqueidad Guarnizione di tenuta -	X	X	X	X	X	X	X	X	X	X											
19	176926	Collier Abrazadera Fascetta -	1	1	1	1	1	1	1	1	1	1											
20	190874	Joint torique Junta tórica Anello OR -	X	X	X	X	X	X	X	X	X	X											
21	211708	Flexible (Lg 1730) Flexible Flessibile -	1	1	1	1	1	1	1	1	1	1											
22	190887	Raccord Union Racor Raccordo -	1	1	1	1	1	1	1	1	1	1											

+



Catalogue : 647000

3

HYDRAULIQUE (Circuit direction)  
 HYDRAULIK (Lenkungkreis)  
 HIDRAULICO (Circuito direcci3n)  
 HYDRAULIC (Steering circuit)  
 IDRAULICO (Circuito sterzo)

Qt3-Menge-Cant-Qty-Q.ta

10 BA

342

M

1-	MH20-4T	BUG. S2-E3	11-
2-	MH25-4T	BUG. S2-E3	12-
3-	MSI 20T	S2-E3	13-
4-	MSI 20T	BUG. S2-E3	14-
5-	MSI 25T	S2-E3	15-
6-	MSI 25T	BUG. S2-E3	16-
7-	MSI 30T	S2-E3	17-
8-	MSI 30T	BUG. S2-E3	18-
9-	MSI 35T	S2-E3	19-
10-	MSI 35T	BUG. S2-E3	20-

Rep Hinw Fig Item Rif	Nu0ero Teil-Nr Numero Part-Nr Part-Nr	D3signation Bezeichnung Description Descrizione	1	2	3	4	5	6	7	8	9	10	11	12	13	14	15	16	17	18	19	20	
23	184787	Joint d'3tanch3it3 Junta de estanqueidad Guarnizi3ne di tenuta - Dichtungsring - Seal -	X	X	X	X	X	X	X	X	X	X											
24	482635	Raccord Union Racor Raccordo - Verschraubung - Connection -	1	1	1	1	1	1	1	1	1	1											
25	215937	Raccord Coud3 Crant3 Racor Raccordo - Verschraubung - Connection -	1	1	1	1	1	1	1	1	1	1											
26	189956	Joint torique Junta t3rica Anello OR - "0" ring - "0" ring -	X	X	X	X	X	X	X	X	X	X											
27	525769	Durit (Lg 2200) Tubo flexible Manicotto - Schlauch - Hose -	1	1	1	1	1	1	1	1	1	1											
28	31468	Collier Abrazadera Fascetta - Spannschelle - Clamp -	2	2	2	2	2	2	2	2	2	2											
29	190887	Raccord Union Racor Raccordo - Verschraubung - Connection -	2	2	2	2	2	2	2	2	2	2											
30	235757	Flexible (Lg 2650) Flexible Flessibile - Schlauch - Hose -	2	2	2	2	2	2	2	2	2	2											
31	208541	Bride de fixation Brida de fijaci3n Flangia di fissaggio - Befestigung Klammer - Fastening flange -	2	2	2	2	2	2	2	2	2	2											
32	60845	Vis CHc,M 8- 30-8.8-ZN8/C Tornillo Vite - Schraube - Screw -	2	2	2	2	2	2	2	2	2	2											
33	206182	Collier Abrazadera Fascetta - Spannschelle - Clamp -	1	1	1	1	1	1	1	1	1	1											

+

Catalogue : 647000

4

HYDRAULIQUE (Circuit direction)  
 HYDRAULIK (Lenkungkreis)  
 HIDRAULICO (Circuito direcci3n)  
 HYDRAULIC (Steering circuit)  
 IDRAULICO (Circuito sterzo)

Qt3-Menge-Cant-Qty-Q.ta

10 BA

342

M

1-	MH20-4T	BUG. S2-E3	11-
2-	MH25-4T	BUG. S2-E3	12-
3-	MSI 20T	S2-E3	13-
4-	MSI 20T	BUG. S2-E3	14-
5-	MSI 25T	S2-E3	15-
6-	MSI 25T	BUG. S2-E3	16-
7-	MSI 30T	S2-E3	17-
8-	MSI 30T	BUG. S2-E3	18-
9-	MSI 35T	S2-E3	19-
10-	MSI 35T	BUG. S2-E3	20-

Rep Hinw Fig Item Rif	Num3ro Teil-Nr Numero Part-Nr Part-Nr	D3signation Bezeichnung Descripcion Description Descrizione
34	188798	Patte de fixation Brida de fijaci3n Flangia di fissaggio - Befestigung auge - Fastening lug -
35	238984	Collier Abrazadera Fascetta - Spannschelle - Clamp -
36	25713	Vis H,M 6- 16-8.8-ZN5/C Tornillo Vite - Schraube - Screw -
37	29469	Rondelle M 6 ZN Arandela Rondella - Unterlegscheibe - Washer -
38	25714	Ecrou H ,M 6 ZN Tuerca Dado - Mutter - Nut -

1	2	3	4	5	6	7	8	9	10	11	12	13	14	15	16	17	18	19	20
1	1	1	1	1	1	1	1	1	1	1									
1	1	1	1	1	1	1	1	1	1	1									
1	1	1	1	1	1	1	1	1	1	1									
1	1	1	1	1	1	1	1	1	1	1									



10 CD 32

HYDRAULIQUE (Vérin d' inclinaison) (Inclinaison 10°/12°)  
 HYDRAULIK (Neigungszylinder) (Neigung 10°/12°)  
 HIDRAULICO (Cilindro de inclinación) (Inclinación 10°/12°)  
 HYDRAULIC (Tilting cylinder) (Tilting 10°/12°)  
 IDRAULICO (Cilindro di inclinazione) (Inclinazione 10°/12°)

MH 20-4 T BUGGIE S2-E3  
 MH 25-4 T BUGGIE S2-E3  
 MSI 20 / 25 / 30 / 35 T S2-E3  
 MSI 20 / 25 / 30 / 35 T BUGGIE S2-E3

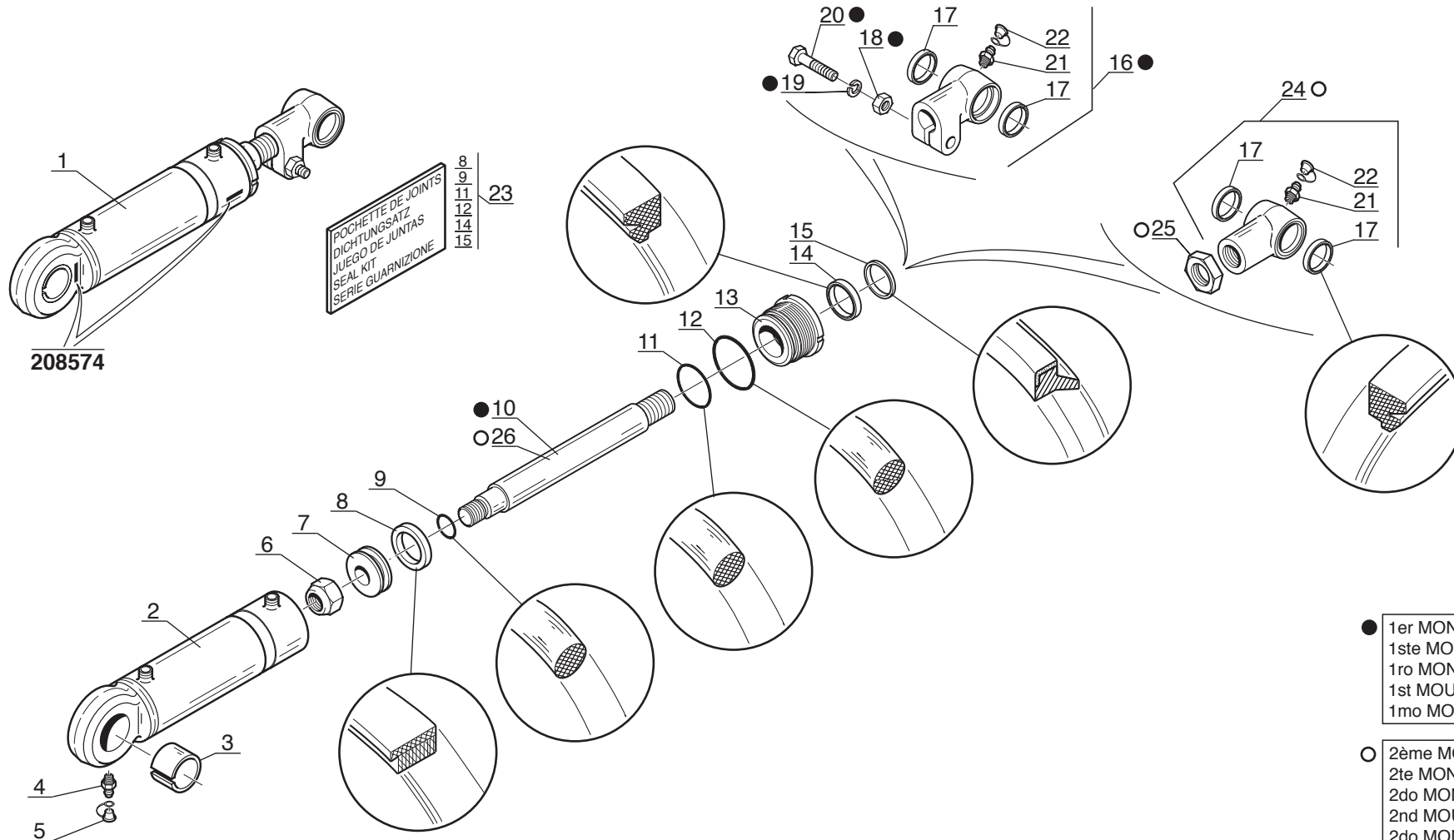
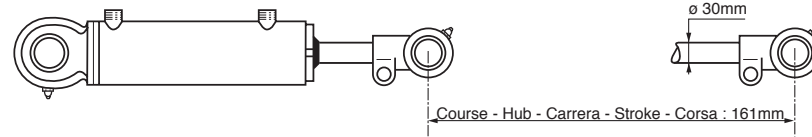

- 1er MONTAGE  
1ste MONTAGE  
1ro MONTAJE  
1st MOUNTING  
1mo MONTAGGIO
- 2ème MONTAGE  
2te MONTAGE  
2do MONTAJE  
2nd MOUNTING  
2do MONTAGGIO

P.A.O. illus

Catalogue : 647000

1			Qté-Menge-Cant-Qty-Q.ta																	10 CD	32	M															
HYDRAULIQUE (Vérin d'inclinaison) (Standard 10°/12°) HYDRAULIK (Neigungszylinder) (Standard 10°/12°) HIDRAULICO (Cilindro de inclinación) (Estándard 10°/12°) HYDRAULIC (Tilting cylinder) (Standard 10°/12°) IDRAULICO (Cilindro di inclinazione) (Standard 10°/12°)			1- MH20-4T BUG. S2-E3 11- 2- MH25-4T BUG. S2-E3 12- 3- MSI 20T S2-E3 13- 4- MSI 20T BUG. S2-E3 14- 5- MSI 25T S2-E3 15- 6- MSI 25T BUG. S2-E3 16- 7- MSI 30T S2-E3 17- 8- MSI 30T BUG. S2-E3 18- 9- MSI 35T S2-E3 19- 10- MSI 35T BUG. S2-E3 20-																																		
Rep Hinw Fig Item Rif	Número Teil-Nr Numero Part-Nr Part-Nr	Désignation Bezeichnung Descripcion Description Descrizione	1	2	3	4	5	6	7	8	9	10	11	12	13	14	15	16	17	18	19	20															
1	208574	Vérin inclinai. D:30mm C:161mm- Cilindro de inclinación - Cilindro di inclinazione -	Neigungszylinder - Tilting cylinder -	2	2	2	2	2	2	2	2	2	2																								
2	561266	Corps de vérin Cuerpo de cilindro Corpo di cilindro	- Zylinder körper - Cylinder body -	1	1	1	1	1	1	1	1	1	1																								
3	181246	Bague Anillo Anello	- Büchse - Bushing -	1	1	1	1	1	1	1	1	1	1																								
4	125963	Graisseur Engrasador Ingrassatore	- Schmiernippel - Greaser -	1	1	1	1	1	1	1	1	1	1																								
5	192777	Capuchon Capuchón Cappuccio	- Kappe - Cap -	1	1	1	1	1	1	1	1	1	1																								
6	174505	Ecrou Tuerca Dado	- Mutter - Nut -	1	1	1	1	1	1	1	1	1	1																								
7	548125	Piston de vérin Pistón de cilindro Pistone del cilindro	- Zylinderkolben - Cylinder piston -	1	1	1	1	1	1	1	1	1	1																								
8	548126	Joint d'étanchéité Junta de estanqueidad Guarnizione	- Dichtungsring - Seal -	1	1	1	1	1	1	1	1	1	1																								
9	5077	Joint torique Junta tórica Anello OR	- "0" ring - "0" ring -	1	1	1	1	1	1	1	1	1	1																								
10	561267	Tige de vérin Vástago de cilindro Stelo del cilindro	- Zylinder stange - Cylinder rod -	1	1	1	1	1	1	1	1	1	1																								
11	4040	Joint torique Junta tórica Anello OR	- "0" ring - "0" ring -	1	1	1	1	1	1	1	1	1	1																								

Catalogue : 647000

2	HYDRAULIQUE (Vérin d'inclinaison) (Standard 10°/12°) HYDRAULIK (Neigungszylinder) (Standard 10°/12°) HIDRAULICO (Cilindro de inclinación) (Estándard 10°/12°) HYDRAULIC (Tilting cylinder) (Standard 10°/12°) IDRAULICO (Cilindro di inclinazione) (Standard 10°/12°)			Qté-Menge-Cant-Qty-Q.ta							10 CD		32		M								
	Rep Hinw Fig Item Rif	Numéro Teil-Nr Numero Part-Nr Part-Nr	Désignation Bezeichnung Descripcion Description Descrizione	1	2	3	4	5	6	7	8	9	10	11	12	13	14	15	16	17	18	19	20
				1- MH20-4T BUG. S2-E3	11-																		
				2- MH25-4T BUG. S2-E3	12-																		
				3- MSI 20T S2-E3	13-																		
				4- MSI 20T BUG. S2-E3	14-																		
				5- MSI 25T S2-E3	15-																		
				6- MSI 25T BUG. S2-E3	16-																		
				7- MSI 30T S2-E3	17-																		
				8- MSI 30T BUG. S2-E3	18-																		
				9- MSI 35T S2-E3	19-																		
				10- MSI 35T BUG. S2-E3	20-																		
12	161783	Joint torique Junta tórica Anello OR	- "0" ring - "0" ring -	1	1	1	1	1	1	1	1	1	1										
13	548127	Bague de fermeture Anillo de cierre Anello di chiusura	- Schlussring - Fastening ring -	1	1	1	1	1	1	1	1	1	1										
14	201449	Joint d'étanchéité Junta de estanqueidad Guarnizione di tenuta	- Dichtungsring - Seal -	1	1	1	1	1	1	1	1	1	1										
15	161504	Joint d'étanchéité Junta de estanqueidad Guarnizione	- Dichtungsring - Seal -	1	1	1	1	1	1	1	1	1	1										
16	561268	Embout de vérin d'inclinaison Cabo de cilindro de inclinación Tilt ram end tube Ghiera di cilindro inclinazione	- Gabelkopf der neigezylinder	1	1	1	1	1	1	1	1	1	1										
17	561269	Joint d'étanchéité Junta de estanqueidad Guarnizione	- Dichtungsring - Seal -	2	2	2	2	2	2	2	2	2	2										
18	42324	Ecrou H ,M14 zingué Tuerca Dado	- Mutter - Nut -	1	1	1	1	1	1	1	1	1	1										
19	42256	Rondelle W14 ZN Arandela Rondella	- Unterlegscheibe - Washer -	1	1	1	1	1	1	1	1	1	1										
20	58558	Vis H,M14- 60-8.8-ZN8/C Tornillo Vite	- Schraube - Screw -	1	1	1	1	1	1	1	1	1	1										
21	269	Graisneur Engrasador Ingrassatore	- Schmiernippel - Greaser -	1	1	1	1	1	1	1	1	1	1										
22	192777	Capuchon Capuchón Cappuccio	- Kappe - Cap -	1	1	1	1	1	1	1	1	1	1										

+

Catalogue : 647000

3	HYDRAULIQUE (Vérin d'inclinaison) (Standard 10°/12°) HYDRAULIK (Neigungszylinder) (Standard 10°/12°) HIDRAULICO (Cilindro de inclinación) (Estándard 10°/12°) HYDRAULIC (Tilting cylinder) (Standard 10°/12°) IDRAULICO (Cilindro di inclinazione) (Standard 10°/12°)			Qté-Menge-Cant-Qty-Q.ta										10 CD		32		M					
	Rep Hinw Fig Item Rif	Numéro Teil-Nr Numero Part-Nr Part-Nr	Désignation Bezeichnung Descripcion Description Descrizione	1	2	3	4	5	6	7	8	9	10	11	12	13	14		15	16	17	18	19
23	453905	Pochette de joints Juego de juntas Kit guarnizióni	- Dichtungssatz - Seal kit -	1	1	1	1	1	1	1	1	1	1										
24	65551F203171	Embout de vérin d'inclinaison Cabo de cilindro de inclinación Tilt ram end tube Ghiera di cilindro inclinazione	- Gabelkopf der neigezylinder	1	1	1	1	1	1	1	1	1	1										
25	65552F203071	Ecrou Tuerca Dado	- Mutter - Nut -	1	1	1	1	1	1	1	1	1	1										
26	562338	Tige de vérin Vástago de cilindro Stelo del cilindro	- Zylinder stange - Cylinder rod -	1	1	1	1	1	1	1	1	1	1										

10 CD 33

HYDRAULIQUE (Vérin d' inclinaison) (Inclinaison 6°/6°)  
 HYDRAULIK (Neigungszylinder) (Neigung 6°/6°)  
 HIDRAULICO (Cilindro de inclinación) (Inclinación 6°/6°)  
 HYDRAULIC (Tilting cylinder) (Tilting 6°/6°)  
 IDRAULICO (Cilindro di inclinazione) (Inclinazione 6°/6°)

MH 20-4 T BUGGIE S2-E3  
 MH 25-4 T BUGGIE S2-E3  
 MSI 20 / 25 / 30 / 35 T S2-E3  
 MSI 20 / 25 / 30 / 35 T BUGGIE S2-E3

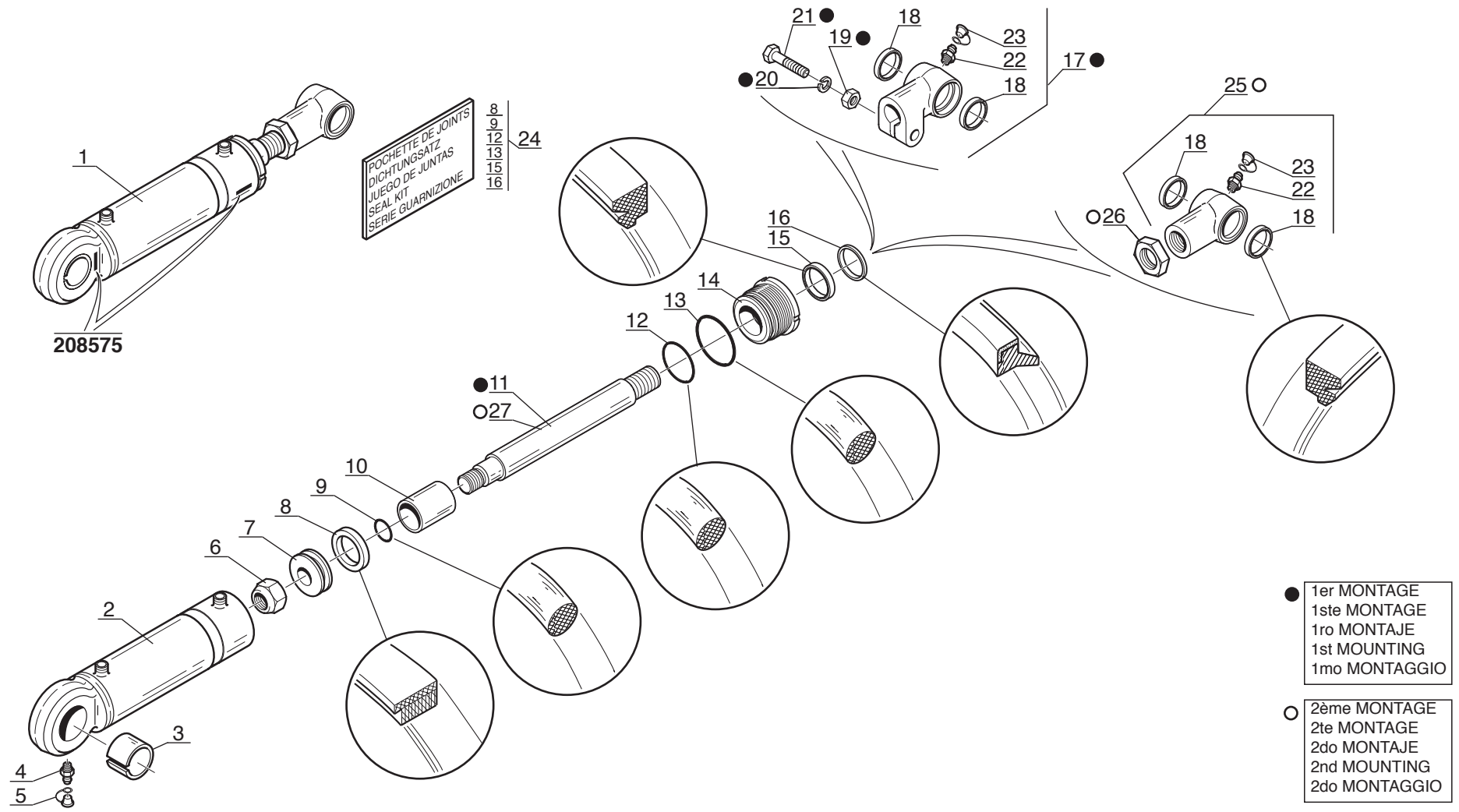
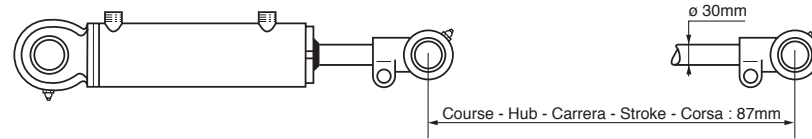



Catalogue : 647000

1				Qté-Menge-Cant-Qty-Q.ta										10 CD					33					M
HYDRAULIQUE (Vérin d'inclinaison) (Standard 6°/6°) HYDRAULIK (Neigungszylinder) (Standard 6°/6°) HIDRAULICO (Cilindro de inclinación) (Estándard 6°/6°) HYDRAULIC (Tilting cylinder) (Standard 6°/6°) IDRAULICO (Cilindro di inclinazione) (Standard 6°/6°)				1- MH20-4T BUG. S2-E3 11- 2- MH25-4T BUG. S2-E3 12- 3- MSI 20T S2-E3 13- 4- MSI 20T BUG. S2-E3 14- 5- MSI 25T S2-E3 15- 6- MSI 25T BUG. S2-E3 16- 7- MSI 30T S2-E3 17- 8- MSI 30T BUG. S2-E3 18- 9- MSI 35T S2-E3 19- 10- MSI 35T BUG. S2-E3 20-																				
Rep Hinw Fig Item Rif	Numéro Teil-Nr Numero Part-Nr Part-Nr	Désignation Bezeichnung Descripcion Descrizione		1	2	3	4	5	6	7	8	9	10	11	12	13	14	15	16	17	18	19	20	
1	208575	Vérin inclinai. D:30mm C: 87mm- Cilindro de inclinación Cilindro di inclinazione	Neigungszylinder - Tilting cylinder -																					
2	561266	Corps de vérin Cuerpo de cilindro Corpo di cilindro	- Zylinder körper - Cylinder body -																					
3	181246	Bague Anillo Anello	- Büchse - Bushing -																					
4	125963	Graisseur Engrasador Ingrassatore	- Schmiernippel - Greaser -																					
5	192777	Capuchon Capuchón Cappuccio	- Kappe - Cap -																					
6	174505	Ecrou Tuerca Dado	- Mutter - Nut -																					
7	548125	Piston de vérin Pistón de cilindro Pistone del cilindro	- Zylinderkolben - Cylinder piston -																					
8	548126	Joint d'étanchéité Junta de estanqueidad Guarnizione	- Dichtungsring - Seal -																					
9	5077	Joint torique Junta tórica Anello OR	- "O" ring - "O" ring -																					
10	561271	Entretoise Separador Distanziale	- Querstrebe - Spacer -																					
11	561270	Tige de vérin Vástago de cilindro Stelo del cilindro	- Zylinder stange - Cylinder rod -																					

Catalogue : 647000

2

HYDRAULIQUE (Vérin d'inclinaison) (Standard 6°/6°)  
 HYDRAULIK (Neigungszylinder) (Standard 6°/6°)  
 HIDRAULICO (Cilindro de inclinación) (Estándard 6°/6°)  
 HYDRAULIC (Tilting cylinder) (Standard 6°/6°)  
 IDRAULICO (Cilindro di inclinazione) (Standard 6°/6°)

Qté-Menge-Cant-Qty-Q.ta

10 CD

33

M

1- MH20-4T BUG. S2-E3 11-  
 2- MH25-4T BUG. S2-E3 12-  
 3- MSI 20T S2-E3 13-  
 4- MSI 20T BUG. S2-E3 14-  
 5- MSI 25T S2-E3 15-  
 6- MSI 25T BUG. S2-E3 16-  
 7- MSI 30T S2-E3 17-  
 8- MSI 30T BUG. S2-E3 18-  
 9- MSI 35T S2-E3 19-  
 10- MSI 35T BUG. S2-E3 20-

Rep Hinw Fig Item Rif	Número Teil-Nr Numero Part-Nr Part-Nr	Désignation Bezeichnung Descripcion Description Descrizione	1	2	3	4	5	6	7	8	9	10	11	12	13	14	15	16	17	18	19	20	
12	4040	Joint torique - "0" ring Junta tórica - "0" ring Anello OR -																					
13	161783	Joint torique - "0" ring Junta tórica - "0" ring Anello OR -																					
14	548127	Bague de fermeture - Schlussring Anillo de cierre - Fastening ring Anello di chiusura -																					
15	201449	Joint d'étanchéité - Dichtungsring Junta de estanqueidad - Seal Guarnizione di tenuta -																					
16	161504	Joint d'étanchéité - Dichtungsring Junta de estanqueidad - Seal Guarnizione -																					
17	561268	Embout de vérin d'inclinaison - Gabelkopf der neigezylinder Cabo de cilindro de inclinación Tilt ram end tube Ghiera di cilindro inclinazione																					
18	561269	Joint d'étanchéité - Dichtungsring Junta de estanqueidad - Seal Guarnizione -																					
19	42324	Ecrou H ,M14 zingué - Mutter Tuerca - Nut Dado -																					
20	42256	Rondelle W14 ZN - Unterlegscheibe Arandela - Washer Rondella -																					
21	58558	Vis H,M14- 60-8.8-ZN8/C - Schraube Tornillo - Screw Vite -																					
22	269	Graisseur - Schmiernippel Engrasador - Greaser Ingrassatore -																					

+

Catalogue : 647000

3	HYDRAULIQUE (Vérin d'inclinaison) (Standard 6°/6°) HYDRAULIK (Neigungszylinder) (Standard 6°/6°) HIDRAULICO (Cilindro de inclinación) (Estándard 6°/6°) HYDRAULIC (Tilting cylinder) (Standard 6°/6°) IDRAULICO (Cilindro di inclinazione) (Standard 6°/6°)			Qté-Menge-Cant-Qty-Q.ta										10 CD		33		M					
	Rep Hinw Fig Item Rif	Numéro Teil-Nr Numero Part-Nr Part-Nr	Désignation Bezeichnung Descripcion Description Descrizione	1	2	3	4	5	6	7	8	9	10	11	12	13	14		15	16	17	18	19
23	192777	Capuchon Capuchón Cappuccio	- Kappe - Cap -																				
24	453905	Pochette de joints Juego de juntas Kit guarnizióni	- Dichtungssatz - Seal kit -																				
25	65551F203171	Embout de vérin d'inclinaison Cabo de cilindro de inclinación Tilt ram end tube Ghiera di cilindro inclinazione	- Gabelkopf der neigezylinder																				
26	65552F203071	Ecrou Tuerca Dado	- Mutter - Nut -																				
27	562339	Tige de vérin Vástago de cilindro Stelo del cilindro	- Zylinder stange - Cylinder rod -																				

10 CE 32

HYDRAULIQUE (Vérin de direction)  
HYDRAULIK (Lenkungszylinder)  
HIDRAULICO (Cilindro de direccion)  
HYDRAULIC (Steering cylinder)  
IDRAULICO (Cilindro di sterzo)

MH 20-4 T BUGGIE S2-E3  
MH 25-4 T BUGGIE S2-E3

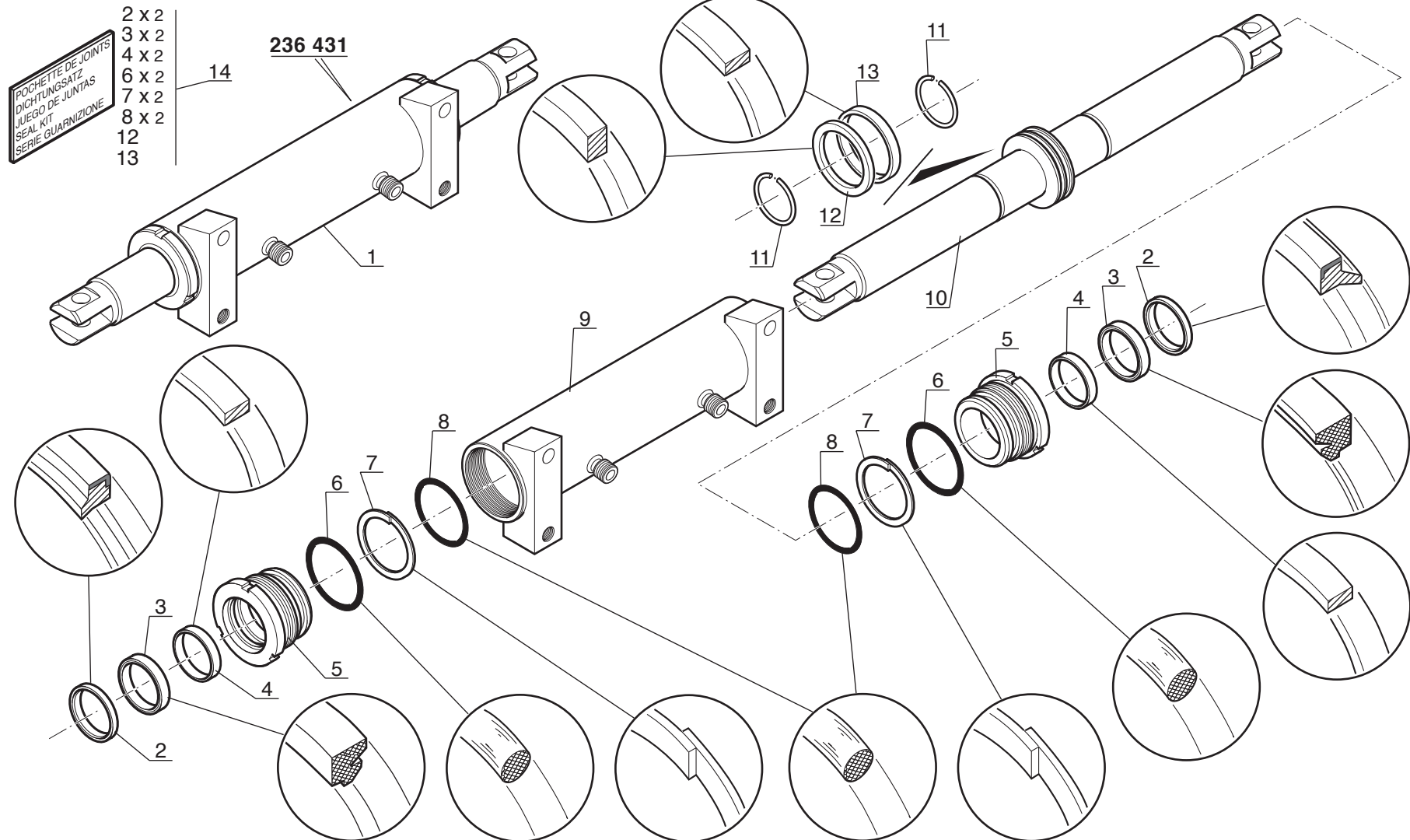
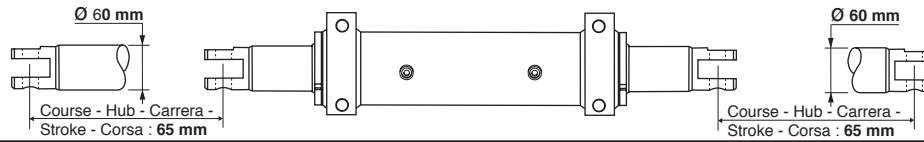

Catalogue : 647000

1			Qté-Menge-Cant-Qty-Q.ta																	10 CE	32	M
HYDRAULIQUE (Vérin de direction) HYDRAULIK (Lenkungszylinder) HIDRAULICO (Cilindro de dirección) HYDRAULIC (Steering cylinder) IDRAULICO (Cilindro di sterzo)			1- MH20-4T BUG. S2-E3 11- 2- MH25-4T BUG. S2-E3 12- 3- MSI 20T S2-E3 13- 4- MSI 20T BUG. S2-E3 14- 5- MSI 25T S2-E3 15- 6- MSI 25T BUG. S2-E3 16- 7- MSI 30T S2-E3 17- 8- MSI 30T BUG. S2-E3 18- 9- MSI 35T S2-E3 19- 10- MSI 35T BUG. S2-E3 20-																			
Rep Hinw Fig Item Rif	Numéro Teil-Nr Numero Part-Nr Part-Nr	Désignation Bezeichnung Descripcion Description Descrizione	1	2	3	4	5	6	7	8	9	10	11	12	13	14	15	16	17	18	19	20
1	236431	Vérin direction D:60mm C:2x65mm Lenkungszylinder Cilindro de dirección - Steering cylinder Cilindro di sterzo -	1	1																		
2	5308	Joint d'étanchéité - Dichtungsring Junta de estanqueidad - Seal Guarnizione -	2	2																		
3	552768	Joint d'étanchéité - Dichtungsring Junta de estanqueidad - Seal Guarnizione -	2	2																		
4	561593	Joint d'étanchéité - Dichtungsring Junta de estanqueidad - Seal Guarnizione -	2	2																		
5	603661	Bague de fermeture - Schlussring Anillo de cierre - Fastening ring Anello di chiusura -	2	2																		
6	187897	Joint torique - "O" ring Junta tórica - "O" ring Anello OR -	2	2																		
7	187898	Joint anti-extrusion - Abstützdichtung Junta antiextrusión - Anti-extrusion seal Guarnizione -	2	2																		
8	603662	Joint torique - "O" ring Junta tórica - "O" ring Anello OR -	2	2																		
9	706644	Corps de vérin - Zylinder körper Cuerpo de cilindro - Cylinder body Corpo di cilindro -	1	1																		
10	603664	Tige de vérin - Zylinder stange Vástago de cilindro - Cylinder rod Stelo del cilindro -	1	1																		
11	169672	Jonc d'arrêt - Sprengring Anillo de parada - Snap ring Giunto -	2	2																		

+

**Catalogue : 647000**

**2**

HYDRAULIQUE (Vérin de direction)  
 HYDRAULIK (Lenkungszylinder)  
 HIDRAULICO (Cilindro de dirección)  
 HYDRAULIC (Steering cylinder)  
 IDRAULICO (Cilindro di sterzo)

**Qté-Menge-Cant-Qty-Q.ta**

**10 CE**

**32**

**M**

1-	MH20-4T	BUG. S2-E3	11-
2-	MH25-4T	BUG. S2-E3	12-
3-	MSI 20T	S2-E3	13-
4-	MSI 20T	BUG. S2-E3	14-
5-	MSI 25T	S2-E3	15-
6-	MSI 25T	BUG. S2-E3	16-
7-	MSI 30T	S2-E3	17-
8-	MSI 30T	BUG. S2-E3	18-
9-	MSI 35T	S2-E3	19-
10-	MSI 35T	BUG. S2-E3	20-

Rep Hinw Fig Item Rif	Numéro Teil-Nr Numero Part-Nr Part-Nr	Désignation Bezeichnung Descripcion Description Descrizione
12	561624	Joint d'étanchéité Junta de estanqueidad Guarnizióne - Dichtungsring - Seal -
13	561625	Joint d'étanchéité Junta de estanqueidad Guarnizióne - Dichtungsring - Seal -
14	603665	Pochette de joints Juego de juntas Kit guarnizióni - Dichtungssatz - Seal kit -

1	2	3	4	5	6	7	8	9	10	11	12	13	14	15	16	17	18	19	20
1	1																		
1	1																		
1	1																		



10 CE 33

HYDRAULIQUE (Vérin de direction)  
HYDRAULIK (Lenkungszylinder)  
HIDRAULICO (Cilindro de direccion)  
HYDRAULIC (Steering cylinder)  
IDRAULICO (Cilindro di sterzo)

MSI 20 / 25 / 30 / 35 T S2-E3  
MSI 20 / 25 / 30 / 35 T BUGGIE S2-E3

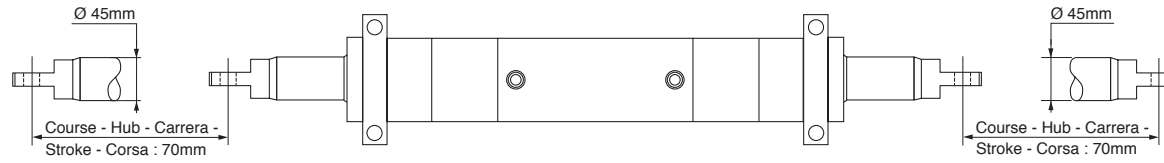

- POCHETTE DE JOINTS  
DICHTUNGSATZ  
JUEGO DE JUNTAS  
SEAL KIT  
SERIE GUARNIZIONE
- 2 x 2
  - 3 x 2
  - 5 x 2
  - 6 x 2
  - 10
  - 11
  - 14
- 12

237 786

● SUIVANT MONTAGE  
NACH MONTAGE  
SEGUN MONTAJE  
AS MOUNTING  
SECONDO MONTAGGIO

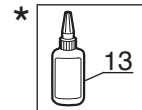
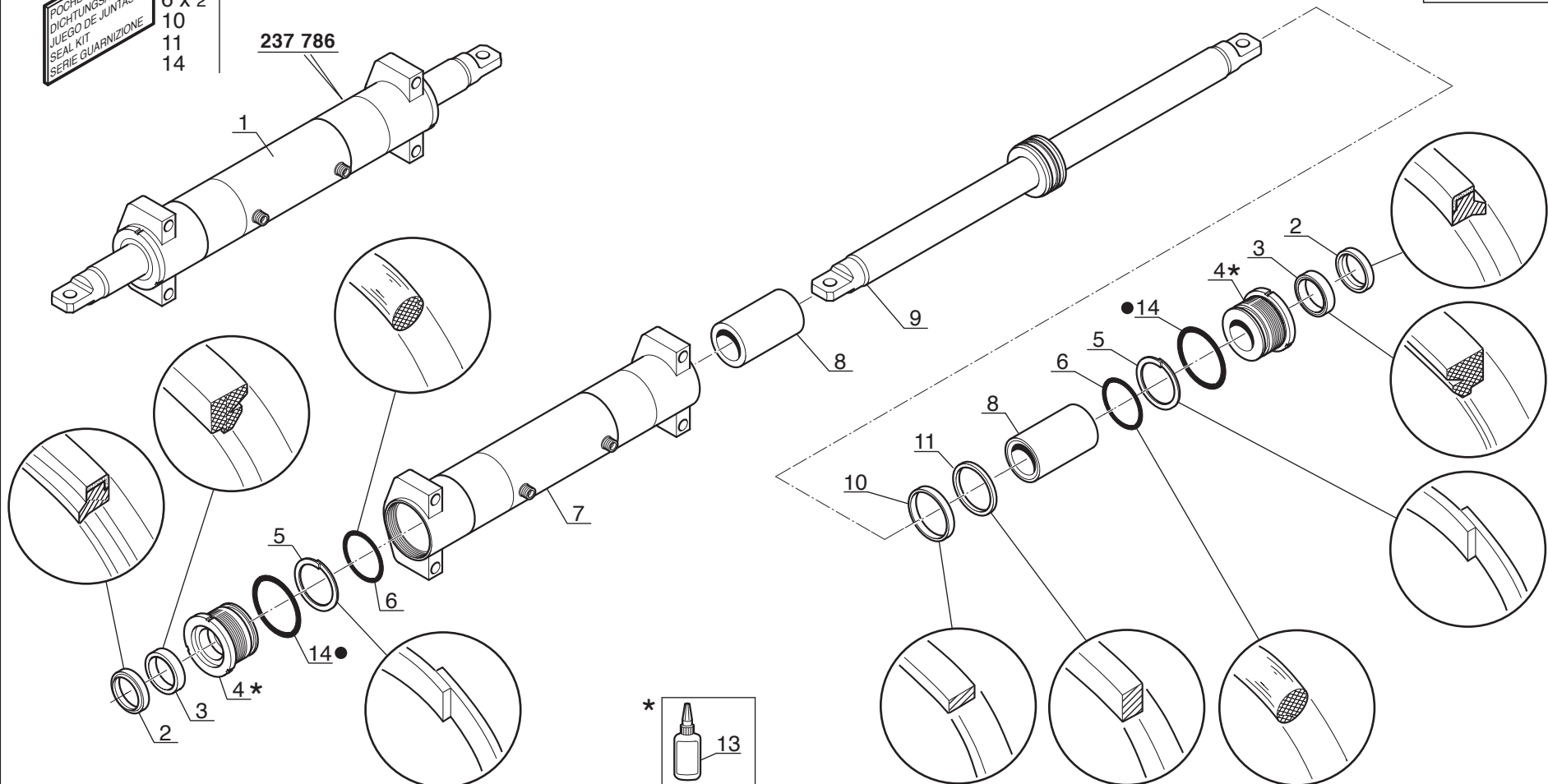



Catalogue : 647000

Qté-Menge-Cant-Qty-Q.ta | 10 CE 33 M

1  
 HYDRAULIQUE (Vérin de direction)  
 HYDRAULIK (Lenkungszylinder)  
 HIDRAULICO (Cilindro de dirección)  
 HYDRAULIC (Steering cylinder)  
 IDRAULICO (Cilindro di sterzo)

1-	MH20-4T	BUG. S2-E3	11-
2-	MH25-4T	BUG. S2-E3	12-
3-	MSI 20T	S2-E3	13-
4-	MSI 20T	BUG. S2-E3	14-
5-	MSI 25T	S2-E3	15-
6-	MSI 25T	BUG. S2-E3	16-
7-	MSI 30T	S2-E3	17-
8-	MSI 30T	BUG. S2-E3	18-
9-	MSI 35T	S2-E3	19-
10-	MSI 35T	BUG. S2-E3	20-

Rep Hinw Fig Item Rif	Numéro Teil-Nr Numero Part-Nr Part-Nr	Désignation Bezeichnung Description Descrizione
-----------------------------------	---	--

1	2	3	4	5	6	7	8	9	10	11	12	13	14	15	16	17	18	19	20
---	---	---	---	---	---	---	---	---	----	----	----	----	----	----	----	----	----	----	----

1	237786	Vérin direction D:45mm C:2x70mm Lenkungszylinder Cilindro de dirección Cilindro di sterzo	- Steering cylinder -
2	165228	Joint d'étanchéité Junta de estanqueidad Guarnizióne	- Dichtungsring - Seal -
3	182294	Joint d'étanchéité Junta de estanqueidad Guarnizióne	- Dichtungsring - Seal -
4	551957	Bague de fermeture Anillo de cierre Anello di chiusura	- Schlussring - Fastening ring -
5	561330	Joint anti-extrusion Junta antiextrusión Guarnizióne	- Abstützdichtung - Anti-extrusion seal -
6	561331	Joint torique Junta tórica Anello OR	- "O" ring - "O" ring -
7	603551	Corps de vérin Cuerpo de cilindro Corpo di cilindro	- Zylinder körper - Cylinder body -
8	561334	Entretoise Separador Distanziale	- Querstrebe - Spacer -
9	603552	Tige de vérin Vástago de cilindro Stelo del cilindro	- Zylinder stange - Cylinder rod -
10	603531	Joint d'étanchéité Junta de estanqueidad Guarnizióne di tenuta	- Dichtungsring - Seal -
11	551951	Joint d'étanchéité Junta de estanqueidad Guarnizióne	- Dichtungsring - Seal -

			1	1	1	1	1	1	1										
				2	2	2	2	2	2	2									
				2	2	2	2	2	2	2									
				2	2	2	2	2	2	2									
				2	2	2	2	2	2	2									
				2	2	2	2	2	2	2									
				1	1	1	1	1	1	1									
				2	2	2	2	2	2	2									
				1	1	1	1	1	1	1									
				1	1	1	1	1	1	1									
				1	1	1	1	1	1	1									

+

Catalogue : 647000

2

HYDRAULIQUE (Vérin de direction)  
 HYDRAULIK (Lenkungszylinder)  
 HIDRAULICO (Cilindro de dirección)  
 HYDRAULIC (Steering cylinder)  
 IDRAULICO (Cilindro di sterzo)

Qté-Menge-Cant-Qty-Q.ta

10 CE

33

M

- 1- MH20-4T BUG. S2-E3 11-
- 2- MH25-4T BUG. S2-E3 12-
- 3- MSI 20T S2-E3 13-
- 4- MSI 20T BUG. S2-E3 14-
- 5- MSI 25T S2-E3 15-
- 6- MSI 25T BUG. S2-E3 16-
- 7- MSI 30T S2-E3 17-
- 8- MSI 30T BUG. S2-E3 18-
- 9- MSI 35T S2-E3 19-
- 10- MSI 35T BUG. S2-E3 20-

Rep Hinw Fig Item Rif	Numéro Teil-Nr Numero Part-Nr Part-Nr	Désignation Bezeichnung Descripcion Description Descrizione																				
			1	2	3	4	5	6	7	8	9	10	11	12	13	14	15	16	17	18	19	20
12	561329	Pochette de joints - Dichtungsatz Juego de juntas - Seal kit Kit guarnizióni -			1	1	1	1	1	1	1	1										
13	62124	Flacon de produit frein filet - Flokon des gewindebremse Frasco de producto de freno fileteado Bottle of stop threaded product Bocceta di prodotti bloccaggio filetto			X	X	X	X	X	X	X	X										
14	705355	Joint torique - "0" ring Junta tórica - "0" ring Anello OR -			2	2	2	2	2	2	2	2										



10 DA 92

DISTRIBUTEUR  
KOMMANDOSTEUERVENTIL  
DISTRIBUIDOR  
VALVE BANK  
DISTRIBUTORE

MH 20-4 T BUGGIE S2-E3  
MH 25-4 T BUGGIE S2-E3  
MSI 20 / 25 / 30 / 35 T S2-E3  
MSI 20 / 25 / 30 / 35 T BUGGIE S2-E3

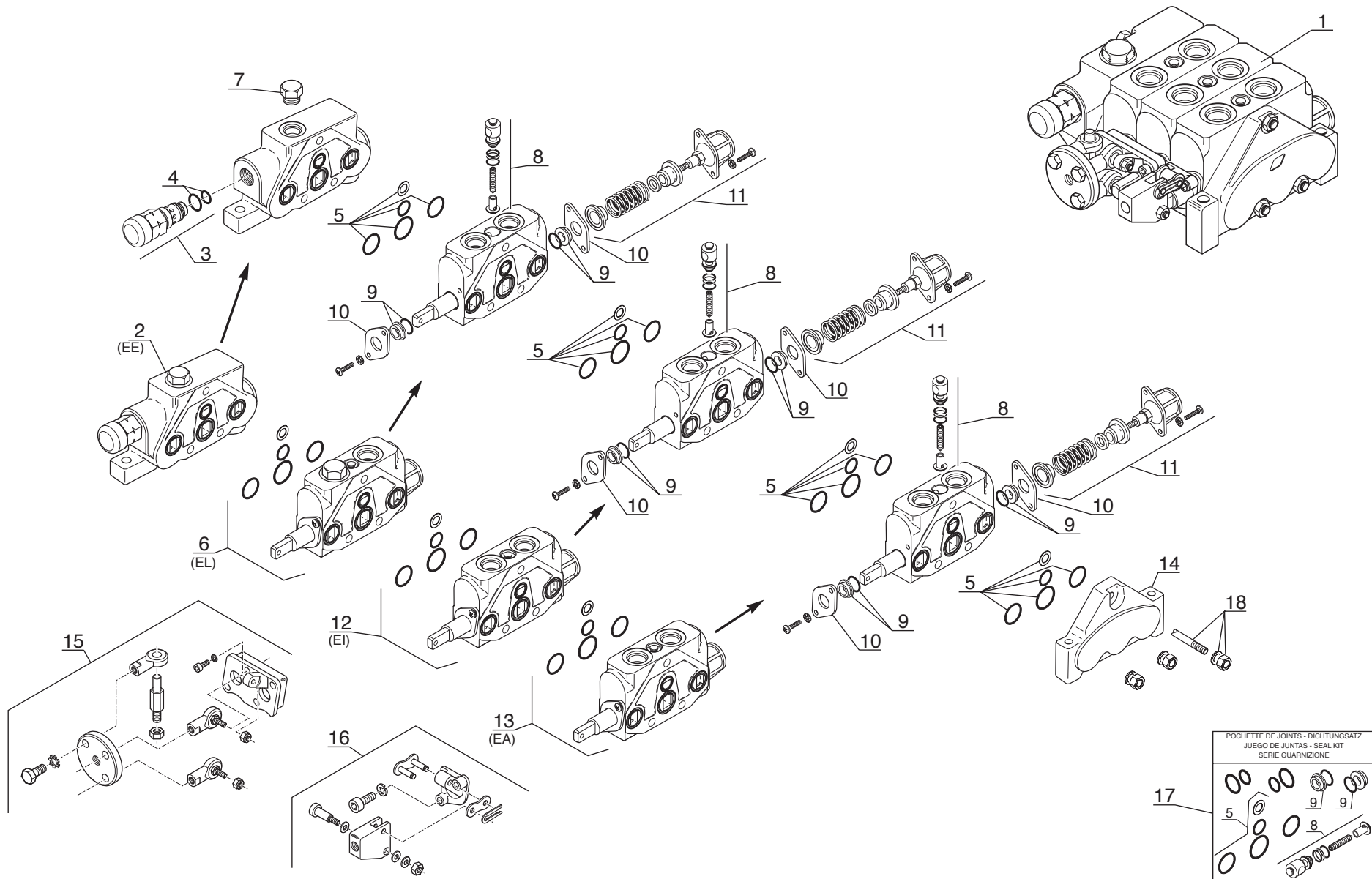

Catalogue : 647000

1	DISTRIBUTEUR KOMMANDOSTEUERVENTIL DISTRIBUIDOR VALVE BANK DISTRIBUTORE			Qté-Menge-Cant-Qty-Q.ta										10 DA		92		M					
	Rep Hinw Fig Item Rif	Numéro Teil-Nr Numero Part-Nr Part-Nr	Désignation Bezeichnung Descripcion Description Descrizione	1	2	3	4	5	6	7	8	9	10	11	12	13	14		15	16	17	18	19
1	219440	Distributeur complet Kompletter kommandosteuerventil Distribuidor completo - Complete valve bank Distributore completo -	1	1	1	1	1	1	1	1	1	1	1										
2	551239	Elément d'entrée - Eingangelement Elemento de entrada - Inlet member Elemento entrada -	1	1	1	1	1	1	1	1	1	1	1										
3	548112	Limiteur de pression - Druckbegrenzungventil Reguladores de presión - Relief valve Limitatore di pressione -	1	1	1	1	1	1	1	1	1	1	1										
4	476318	Joint torique - "0" ring Junta tórica - "0" ring Anello OR -	X	X	X	X	X	X	X	X	X	X	X										
5	476321	Joint d'étanchéité - Dichtungsring Junta de estanqueidad - Seal Guarnizione -	4	4	4	4	4	4	4	4	4	4	4										
6	561638	Elément simple effet (Levage) Einfachwirkendelement (Aufwinden) Elemento simple efecto (Levantamiento) Single-acting member (Lifting) Elemanto semplice effetto (Sollevamento)	1	1	1	1	1	1	1	1	1	1	1										
7	476319	Bouchon - Stopfen Tapón - Plug Tappo -	1	1	1	1	1	1	1	1	1	1	1										
8	476322	Clapet - Klappe Válvula - Valve Valvola -	3	3	3	3	3	3	3	3	3	3	3										
9	476324	Joint d'étanchéité - Dichtungsring Junta de estanqueidad - Seal Guarnizione -	6	6	6	6	6	6	6	6	6	6	6										
10	476325	Plaque - Platte Placa - Plate Piastra -	6	6	6	6	6	6	6	6	6	6	6										

Catalogue : 647000

2

DISTRIBUTEUR  
KOMMANDOSTEUERVENTIL  
DISTRIBUIDOR  
VALVE BANK  
DISTRIBUTORE

Qté-Menge-Cant-Qty-Q.ta

10 DA

92

M

1- MH20-4T BUG. S2-E3 11-  
2- MH25-4T BUG. S2-E3 12-  
3- MSI 20T S2-E3 13-  
4- MSI 20T BUG. S2-E3 14-  
5- MSI 25T S2-E3 15-  
6- MSI 25T BUG. S2-E3 16-  
7- MSI 30T S2-E3 17-  
8- MSI 30T BUG. S2-E3 18-  
9- MSI 35T S2-E3 19-  
10- MSI 35T BUG. S2-E3 20-

Rep Hinw Fig Item Rif	Numéro Teil-Nr Numero Part-Nr Part-Nr	Désignation Bezeichnung Descripcion Description Descrizione																				
			1	2	3	4	5	6	7	8	9	10	11	12	13	14	15	16	17	18	19	20
11	548894	Commande de rappel par ressort- Rückfederantrieb Mando de llamada para resorte - Spring return drive Gruppo comando per molla -	3	3	3	3	3	3	3	3	3	3										
12	476850	Elément double effet - Doppeltwirkendelement Elemento doble efecto - Double-acting member Elemento doble efecto -	1	1	1	1	1	1	1	1	1	1										
13	476850	Elément double effet - Doppeltwirkendelement Elemento doble efecto - Double-acting member Elemento doble efecto -	1	1	1	1	1	1	1	1	1	1										
14	549774	Elément de fermeture - Schlusselement Elemento de cierre - Fastening member Elemanto di chiusura -	1	1	1	1	1	1	1	1	1	1										
15	549185	Commande double - Doppelantrieb Mando doble - Double drive Comando doble -	1	1	1	1	1	1	1	1	1	1										
16	549672	Commande manuelle - Handantrieb Mando manual - Manual drive Comando manuale -	1	1	1	1	1	1	1	1	1	1										
17	192871	Pochette de joints - Dichtungsatz Juego de juntas - Seal kit Serie guarnizióne -	X	X	X	X	X	X	X	X	X	X										
18	549775	Tirant (3 éléments) - Stange (3 element) Tirante (3 elementos) - Tie rod (3 element) Tiranti (3 elemento) -	1	1	1	1	1	1	1	1	1	1										
EA = Elément accessoire EA = Zubehörelement EA = Elemento accesorio EA = Member attachment EA = Elemanto accessori  EE = Elément d'entrée EE = Eingangelement EE = Elemento de entrada EE = Inlet member EE = Elemanto entrata																						

+

**Catalogue : 647000**

**3**

DISTRIBUTEUR  
KOMMANDOSTEUERVENTIL  
DISTRIBUIDOR  
VALVE BANK  
DISTRIBUTORE

**Qté-Menge-Cant-Qty-Q.ta**

**10 DA**

**92**

**M**

1-	MH20-4T	BUG. S2-E3	11-
2-	MH25-4T	BUG. S2-E3	12-
3-	MSI 20T	S2-E3	13-
4-	MSI 20T	BUG. S2-E3	14-
5-	MSI 25T	S2-E3	15-
6-	MSI 25T	BUG. S2-E3	16-
7-	MSI 30T	S2-E3	17-
8-	MSI 30T	BUG. S2-E3	18-
9-	MSI 35T	S2-E3	19-
10-	MSI 35T	BUG. S2-E3	20-

**Rep  
Hinw  
Fig  
Item  
Rif**

**Numéro  
Teil-Nr  
Numero  
Part-Nr  
Part-Nr**

**Désignation  
Bezeichnung  
Descripcion  
Description  
Descrizione**

1 2 3 4 5 6 7 8 9 10 11 12 13 14 15 16 17 18 19 20

EI = Elément d'inclinaison  
EI = Neigungselement  
EI = Elemento inclinación  
EI = Tilting member  
EI = Elemanto inclinazione  
  
EL = Elément de levage  
EL = Aufwindenelement  
EL = Elemento levantamiento  
EL = Lifting member  
EL = Elemanto sollevamento

10 EA 224

HYDRAULIQUE (Détails)  
HYDRAULIK (Einzelteile)  
HIDRAULICO (Detalles)  
HYDRAULIC (Details)  
IDRAULICO (Particolari)

MH 20-4 T BUGGIE S2-E3  
MH 25-4 T BUGGIE S2-E3  
MSI 20 / 25 / 30 / 35 T S2-E3  
MSI 20 / 25 / 30 / 35 T BUGGIE S2-E3

MH 20-4 T BUGGIE S2-E3  
MH 25-4 T BUGGIE S2-E3

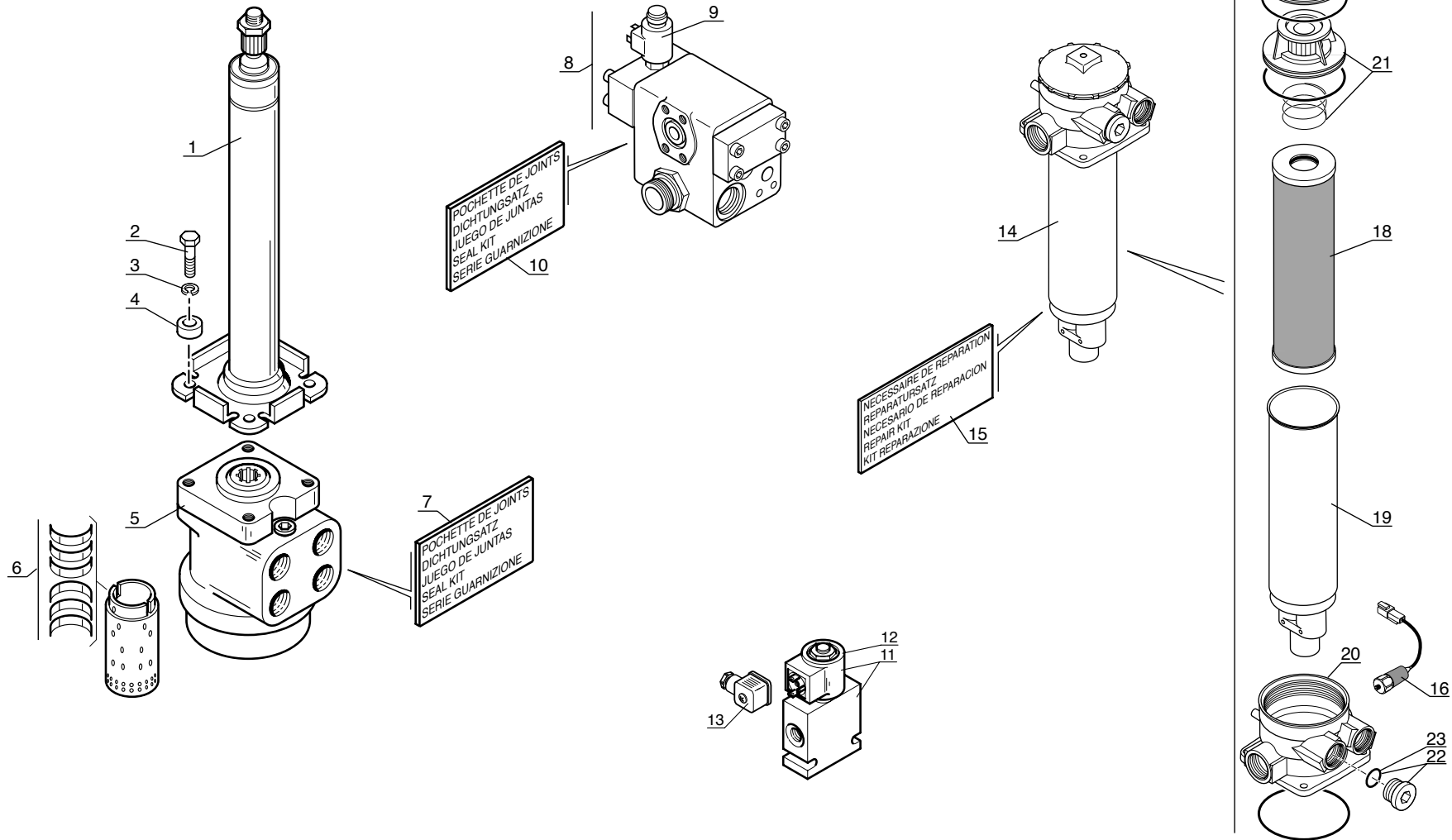



Catalogue : 647000

1	HYDRAULIQUE (Détails) HYDRAULIK (Einzelteile) HIDRAULICO (Detalles) HYDRAULIC (Details) IDRAULICO (Dettaglio)			Qté-Menge-Cant-Qty-Q.ta										10 EA	224	M							
	Rep Hinw Fig Item Rif	Numéro Teil-Nr Numero Part-Nr Part-Nr	Désignation Bezeichnung Description Descrizione	1	2	3	4	5	6	7	8	9	10	11	12	13	14	15	16	17	18	19	20
1	30327	Colonne de direction Columna de dirección Colonna sterzo	- Lenksäule - Steering column -	1	1	1	1	1	1	1	1	1	1										
2	63545	Vis H,M10- 35-8.8-ZN8/C Tornillo Vite	- Schraube - Screw -	4	4	4	4	4	4	4	4	4	4										
3	42232	Rondelle W10 ZN Arandela Rondella	- Unterlegscheibe - Washer -	4	4	4	4	4	4	4	4	4	4										
4	217413	Bague Anillo Anello	- Büchse - Bushing -	4	4	4	4	4	4	4	4	4	4										
5	208583	Corps de pompe de direction Cuerpo de bomba de dirección Corpo di pompa di sterzo	- Lenkung pumpe körper - Steering pump body -	1	1	1	1	1	1	1	1	1	1										
6	169586	Jeux de lamelles Juego de láminas Kit di lamella	- Lamelle satz - Lamella kit -	X	X	X	X	X	X	X	X	X	X										
7	25026	Pochette de joints Juego de juntas Serie guarnizione	- Dichtungssatz - Seal kit -	X	X	X	X	X	X	X	X	X	X										
8	247704	Bloc d'alimentation droit Bloque de alimentación derecho- Blocco alimentazione destro	- Recht Zuschiebungblock - R.H. feed block -	1	1																		
9	603828	Solénoïde Solenoid Solenoid	- Solenoid - Solenoid -	1	1																		
10	603829	Pochette de joints Juego de juntas Kit guarnizióni	- Dichtungssatz - Seal kit -	1	1																		
11	202243	Electrovalve complète Electroválvula completa Electrovalvola completa	- Kompletter elektroventil - Complete electrovalve -	1	1	1	1	1	1	1	1	1	1										

+

Catalogue : 647000

2

HYDRAULIQUE (Détails)  
 HYDRAULIK (Einzelteile)  
 HIDRAULICO (Detalles)  
 HYDRAULIC (Details)  
 IDRAULICO (Dettaglio)

Qté-Menge-Cant-Qty-Q.ta

10 EA

224

M

1-	MH20-4T	BUG. S2-E3	11-
2-	MH25-4T	BUG. S2-E3	12-
3-	MSI 20T	S2-E3	13-
4-	MSI 20T	BUG. S2-E3	14-
5-	MSI 25T	S2-E3	15-
6-	MSI 25T	BUG. S2-E3	16-
7-	MSI 30T	S2-E3	17-
8-	MSI 30T	BUG. S2-E3	18-
9-	MSI 35T	S2-E3	19-
10-	MSI 35T	BUG. S2-E3	20-

Rep Hinw Fig Item Rif	Numéro Teil-Nr Numero Part-Nr Part-Nr	Désignation Bezeichnung Description Description	1	2	3	4	5	6	7	8	9	10	11	12	13	14	15	16	17	18	19	20
12	548870	Solénoïde Solenoid Solenoid Solenoid	-	-	-	-	-	-	-	-	-	-	-	-	-	-	-	-	-	-	-	-
13	602305	Connecteur (noir) Conectador Connettore	-	-	-	-	-	-	-	-	-	-	-	-	-	-	-	-	-	-	-	-
14	246904	Filtre à huile retour hydraulique complet Kompletter hydraulik ruckgang Ölfilter Filtro de aceite retorno hidraulico completo Complete hydraulic return oil filter Filtro dio idraulico completo -	-	-	-	-	-	-	-	-	-	-	-	-	-	-	-	-	-	-	-	-
15	602098	Nécessaire de réparation Necesario de reparación Kit riparazione	-	-	-	-	-	-	-	-	-	-	-	-	-	-	-	-	-	-	-	-
16	602099	Contacteur colmatage filtre à huile retour hydraulique Hydraulik ruckgang slfilter ablagerung schalter Contactor colmatado filtro de aceite retorno hidraulico Hydraulic return oil filter clogging switch Contattore intasamento filtro dell'olio ritorno idraulico	-	-	-	-	-	-	-	-	-	-	-	-	-	-	-	-	-	-	-	-
17	602094	Couvercle Tapadera Coperchio	-	-	-	-	-	-	-	-	-	-	-	-	-	-	-	-	-	-	-	-
18	602096	Cartouche filtre à huile retour hydraulique Patrone hydraulik ruckgang olfilter Cartucho filtro aceite retorno hidraulico Cartridge hydraulic return oil filter Cartuccia filtro olio ritorno idraulico	-	-	-	-	-	-	-	-	-	-	-	-	-	-	-	-	-	-	-	-
19	703013	Jupe du filtre Faldón de filtro Manicotto	-	-	-	-	-	-	-	-	-	-	-	-	-	-	-	-	-	-	-	-
20	602095	Corps du filtre à huile retour hydraulique Hydraulik ruckgang slfilter körper Cuerpo de filtro de aceite retorno hidraulico Hydraulic return oil filter body Corpo filtro dio idraulico -	-	-	-	-	-	-	-	-	-	-	-	-	-	-	-	-	-	-	-	-

+

Catalogue : 647000

3

HYDRAULIQUE (Détails)  
 HYDRAULIK (Einzelteile)  
 HIDRAULICO (Detalles)  
 HYDRAULIC (Details)  
 IDRAULICO (Dettaglio)

Qté-Menge-Cant-Qty-Q.ta

10 EA

224

M

1-	MH20-4T	BUG. S2-E3	11-
2-	MH25-4T	BUG. S2-E3	12-
3-	MSI 20T	S2-E3	13-
4-	MSI 20T	BUG. S2-E3	14-
5-	MSI 25T	S2-E3	15-
6-	MSI 25T	BUG. S2-E3	16-
7-	MSI 30T	S2-E3	17-
8-	MSI 30T	BUG. S2-E3	18-
9-	MSI 35T	S2-E3	19-
10-	MSI 35T	BUG. S2-E3	20-

Rep Hinw Fig Item Rif	Numéro Teil-Nr Numero Part-Nr Part-Nr	Désignation Bezeichnung Descripcion Description Descrizione	1	2	3	4	5	6	7	8	9	10	11	12	13	14	15	16	17	18	19	20	
21	706496	Plaque entretoise Placa separador Piastra distanziale - Strebesplatte - Strut plate -	1	1	1	1	1	1	1	1	1	1											
22	217130	Bouchon Tapón Tappo - Stopfen - Plug -	1	1	1	1	1	1	1	1	1	1											
23	190875	Joint d'étanchéité Junta de estanqueidad Guarnizione - Dichtungsring - Seal -	1	1	1	1	1	1	1	1	1	1											



Catalogue : 647000

Qté-Menge-Cant-Qty-Q.ta 11 AA 1283

M

Rep Hinw Fig Item Rif	Numéro Teil-Nr Numero Part-Nr Part-Nr	Désignation Bezeichnung Description Descrizione	11 AA 1283																			
			1	2	3	4	5	6	7	8	9	10	11	12	13	14	15	16	17	18	19	20
1	552672	Moteur d'essuie-glace - Scheibenwischer motor Motor de limpiaparabrisas - Windshield-wiper motor Motorino tergiacristallo -			1	1	1	1	1	1	1	1										
2	20125	Avertisseur - Hüpe Bocina - Horn Signalatore acustico -			1	1	1	1	1	1	1	1										
3	211012	Relais levage cabine - Relais Cab lifting Relé levantamiento cabina - Cab lifting relay Centralina rele sollevamento cabina			1	1	1	1	1	1	1	1										
4	223594	Coupe-batterie - Unterbrecher Corte batería - Breaker circuit Interruttore batteria -			1	1	1	1	1	1	1	1										
5	247816	Câble - Kabel Cable - Cable Cavo -			1	1	1	1	1	1	1	1										
6	176737	Vibrateur sonore - Summer Vibrador sonoro - Buzzer Buzzer -			1	1	1	1	1	1	1	1										
7	231243	Relais - Relais Relé - Relay Centralina rele -			1	1	1	1	1	1	1	1										
8	245700	Relais - Relais Relé - Relay Centralina rele -			1	1	1	1	1	1	1	1										
9	225183	Relais - Relais Relé - Relay Centralina rele -			1	1	1	1	1	1	1	1										
10	229040	Diode - Diode Diodo - Diode Diodo -			1	1	1	1	1	1	1	1										
11	225183	Relais - Relais Relé - Relay Centralina rele -			1	1	1	1	1	1	1	1										

+

Catalogue : 647000

2

CIRCUIT ELECTRIQUE  
STROMKREIS  
CIRCUITO ELECTRICO  
ELECTRIC CIRCUIT  
IMPIANTO ELETRICO

Qté-Menge-Cant-Qty-Q.ta

11 AA

1283

M

1- MH20-4T BUG. S2-E3 11-  
2- MH25-4T BUG. S2-E3 12-  
3- MSI 20T S2-E3 13-  
4- MSI 20T BUG. S2-E3 14-  
5- MSI 25T S2-E3 15-  
6- MSI 25T BUG. S2-E3 16-  
7- MSI 30T S2-E3 17-  
8- MSI 30T BUG. S2-E3 18-  
9- MSI 35T S2-E3 19-  
10- MSI 35T BUG. S2-E3 20-

Rep Hinw Fig Item Rif	Numéro Teil-Nr Numero Part-Nr Part-Nr	Désignation Bezeichnung Descripcion Description Descrizione	Qté-Menge-Cant-Qty-Q.ta																			
			1	2	3	4	5	6	7	8	9	10	11	12	13	14	15	16	17	18	19	20
12	246918	Interrupteur - Schalter Interruptor - Switch Interruttore -			1	1	1	1	1	1	1	1										
13	224765	Interrupteur essuie-glace arrière + toit Hinten scheibenwischer schalter + dach Interruptor limpiaparabrisas trasera + techo Rear windshield-wiper switch + roof Interruttore tergicristallo posteriore + tetto			1	1	1	1	1	1	1	1										
14	224766	Interrupteur essuie-glace + Lave glace Scheibenwischer schalter + Scheibenwashanlage Interruptor limpiaparabrisas + Lavaparabrisas Windshield-wiper switch + Windscren washer Interruttore tergicristallo + Lavacristalli			1	1	1	1	1	1	1	1										
15	236325	Interrupteur frein de parcage - Festellbremse schalter Interruptor freno de estacionamiento Parking bracke switch Interruttore freno -			1	1	1	1	1	1	1	1										
16	184817	Contacteur à clé - Zündschalter Contactor a llave - Ignition switch Interruttore chiave -			1	1	1	1	1	1	1	1										
17	202884	Contacteur avertisseur - Hüpe schalter Contactor bocina - Horn switch Contattore segnalatore acustico			1	1	1	1	1	1	1	1										
18	202701	Faisceau - Kabelbaum Haz - Wiring harness Fascio -			1	1	1	1	1	1	1	1										
19	272195	Pompe d'alimentation - Brennstoffpumpe Bomba de alimentación - Fuel pump Pompa alimentazione -			1	1	1	1	1	1	1	1										
20	202243	Electrovalve complète - Kompletter elektroventil Electroválvula completa - Complete electrovalve Electrovalvola completa -			1	1	1	1	1	1	1	1										
21	602063	Distributeur - Kommandosteuerventil Distribuidor - Valve bank Distributore -			1	1	1	1	1	1	1	1										

+

Catalogue : 647000

3

CIRCUIT ELECTRIQUE  
STROMKREIS  
CIRCUITO ELECTRICO  
ELECTRIC CIRCUIT  
IMPIANTO ELETRICO

Qté-Menge-Cant-Qty-Q.ta

11 AA

1283

M

1- MH20-4T BUG. S2-E3 11-  
2- MH25-4T BUG. S2-E3 12-  
3- MSI 20T S2-E3 13-  
4- MSI 20T BUG. S2-E3 14-  
5- MSI 25T S2-E3 15-  
6- MSI 25T BUG. S2-E3 16-  
7- MSI 30T S2-E3 17-  
8- MSI 30T BUG. S2-E3 18-  
9- MSI 35T S2-E3 19-  
10- MSI 35T BUG. S2-E3 20-

Rep Hinw Fig Item Rif	Numéro Teil-Nr Numero Part-Nr Part-Nr	Désignation Bezeichnung Descripcion Description Descrizione	Qté-Menge-Cant-Qty-Q.ta																			
			1	2	3	4	5	6	7	8	9	10	11	12	13	14	15	16	17	18	19	20
22	274948	Faisceau - Kabelbaum Haz - Wiring harness Fascio -			1	1	1	1	1	1	1	1										
23	602099	Contacteur colmatage filtre à huile retour hydraulique Hydraulik ruckgang sfilter ablagerung schalter Contactor colmatado filtro de aceite retorno hidraulico Hydraulic return oil filter clogging switch Contattore intasamento filtro dell'olio ritorno idraulico			1	1	1	1	1	1	1	1										
24	748014	Démarrreur - Anlasser Arrancador - Starter motor Motorino avviamento -			1	1	1	1	1	1	1	1										
25	565345	Mano-contact pression huile moteur Ol motor druckschalter Mano contacto presión de aceite motor Engine oil pressure switch Interruttore pressione olio motore			1	1	1	1	1	1	1	1										
26	247817	Câble - Kabel Cable - Cable Cavo -			1	1	1	1	1	1	1	1										
27	247068	Batterie - Batterie Batería - Battery Batteria -			1	1	1	1	1	1	1	1										
28	250281	Câble - Kabel Cable - Cable Cavo -			1	1	1	1	1	1	1	1										
29	243482	Relais - Relais Relé - Relay Centralina rele -			1	1	1	1	1	1	1	1										
30	245292	Corps boîte à fusibles - Lichtsicherungsbüchse körper Cuerpo caja de fusibles - Fuses box body Corpo scatola valvole -			1	1	1	1	1	1	1	1										
31	224776	Indicateur colmatage filtre à air Luftfilter ablagerung schalter Contactor colmatado filtro de aire Air filter clogging switch Indicatore filtro aria -			1	1	1	1	1	1	1	1										

+

Catalogue : 647000

4

CIRCUIT ELECTRIQUE  
STROMKREIS  
CIRCUITO ELECTRICO  
ELECTRIC CIRCUIT  
IMPIANTO ELETRICO

Qté-Menge-Cant-Qty-Q.ta

11 AA

1283

M

1- MH20-4T BUG. S2-E3 11-  
2- MH25-4T BUG. S2-E3 12-  
3- MSI 20T S2-E3 13-  
4- MSI 20T BUG. S2-E3 14-  
5- MSI 25T S2-E3 15-  
6- MSI 25T BUG. S2-E3 16-  
7- MSI 30T S2-E3 17-  
8- MSI 30T BUG. S2-E3 18-  
9- MSI 35T S2-E3 19-  
10- MSI 35T BUG. S2-E3 20-

Rep Hinw Fig Item Rif	Numéro Teil-Nr Numero Part-Nr Part-Nr	Désignation Bezeichnung Descripcion Description Descrizione	Qté-Menge-Cant-Qty-Q.ta																			
			1	2	3	4	5	6	7	8	9	10	11	12	13	14	15	16	17	18	19	20
32	216357	Jauge à carburant Galga de cargurante Livello carburante	- Kraftstoffmesser - Fuel gauge -			1	1	1	1	1	1	1	1									
33	217332	Faisceau Haz Fascio	- Kabelbaum - Wiring harness -			1	1	1	1	1	1	1	1									
34	706324	Sonde de température d'eau Sonda de temperatura de agua Sonda di temperatura acqua	- Wasser temperatur transmitt - Water temperature sensor -			1	1	1	1	1	1	1	1									
35	245718	Pompe relevage cabine Bomba levantamiento cabina Pompa sollevamento cabina	- Aufwinder kreis pumpe - Cab lifting pump -			1	1	1	1	1	1	1	1									
36	823616	Bougie de préchauffage Bujía de precalentamiento Termostarter	- Glühkerze - Heating plug -			4	4	4	4	4	4	4	4									
37	823584	Solénoïde Solenoid Solenoid Solenoid	- Solenoid - Solenoid -			1	1	1	1	1	1	1	1									
38	551450	Réservoir lave-glace Depósito lavaparabrissas Serbatoio di lavavetro	- Scheibenwisher behälter - Windshield-washer tank -			1	1	1	1	1	1	1	1									
39	252679	Tableau : Horamètre et voyants Enbrett : Stundenzähler und Leuchtzeichenbrett Tablero : Horametro y indicador Panel : Hour recorder and warning light Cruscotto : Tachimetro e segnale				1	1	1	1	1	1	1	1									
40	270452	Faisceau principal Haz principal Fascio principale	- Haupt Kabelbaum - Main wiring harness -			1	1	1	1	1	1	1	1									
41	747985	Alternateur Alternador Alternatore	- Wechselstromgenerator - Alternator -			1	1	1	1	1	1	1	1									
42	220408	Shunt Shunt Shunt	- Nebenschluss - Shunt -			1	1	1	1	1	1	1	1									

+





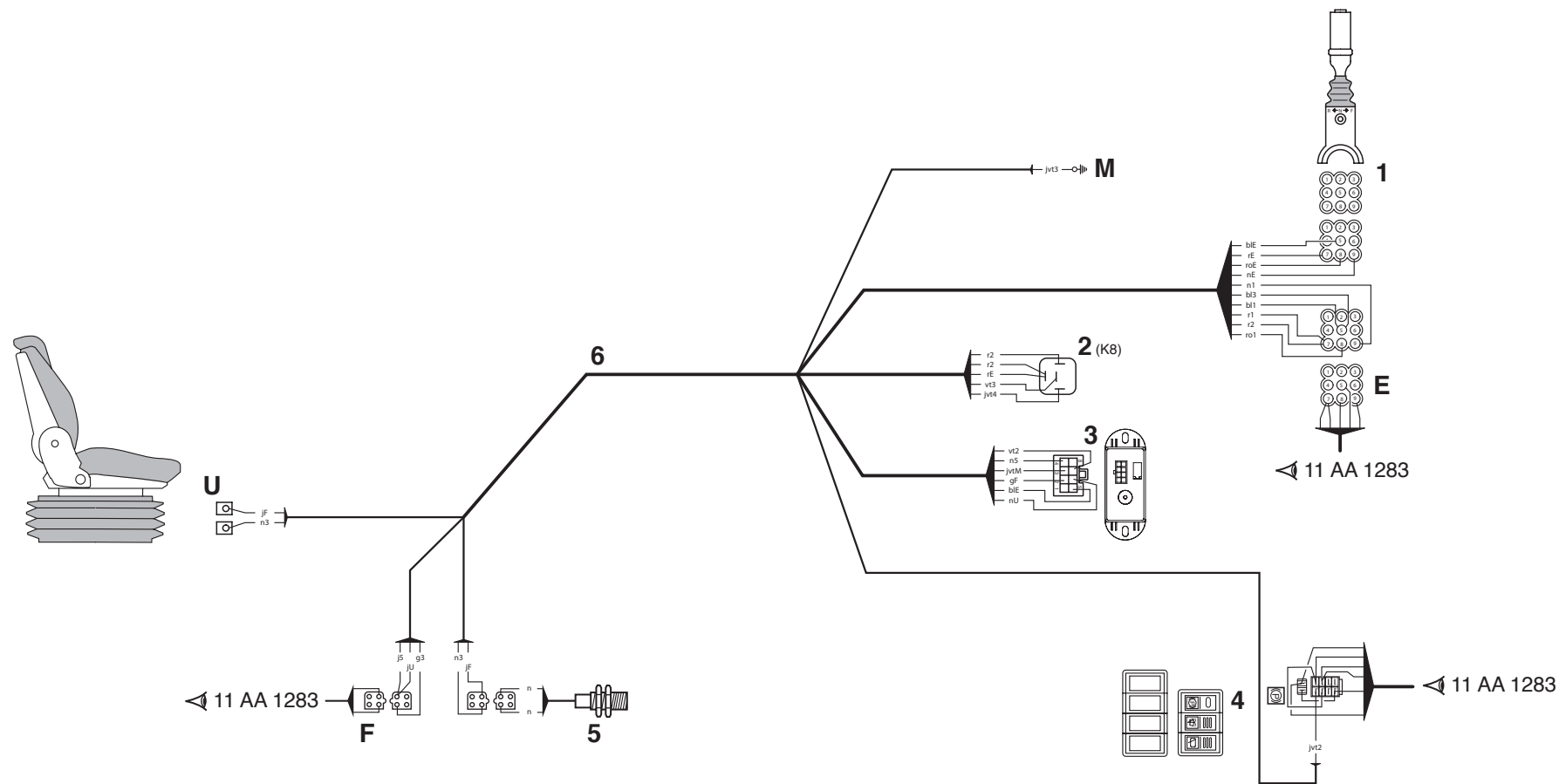

Catalogue : 647000

1	CIRCUIT ELECTRIQUE STROMKREIS CIRCUITO ELECTRICO ELECTRIC CIRCUIT IMPIANTO ELETRICO			Qté-Menge-Cant-Qty-Q.ta										11 AA		1284		M						
	Rep Hinw Fig Item Rif	Numéro Teil-Nr Numero Part-Nr Part-Nr	Désignation Bezeichnung Descripcion Description Descrizione	1	2	3	4	5	6	7	8	9	10	11	12	13	14	15	16	17	18	19	20	
1	234956	Inverseur de marche Inversor de marcha Invertitore di marcia	- Umsteuergetriebe - Reversing gears -			1	1	1	1	1	1	1	1											
2	225183	Relais Relé Centralina rele	- Relais - Relay -			1	1	1	1	1	1	1	1											
3	252261	Module coupure transmission Módulo corte transmisión Modulo di arresto trasmissione-	- Getriebe trenn modul - Transmission cut-off modulus -			1	1	1	1	1	1	1	1											
4	236325	Interrupteur frein de parcage Interruptor freno de estacionamiento Parking bracke switch Interruttore freno	- Feststellbremse schalter - - -			1	1	1	1	1	1	1	1											
5	236963	Détecteur de proximité Detector Segnalatore	- Detektor - Detector -			1	1	1	1	1	1	1	1											
6	252737	Faisceau Haz Fascio  Couleurs :	- Kabelbaum - Wiring harness -  bc Blanc - Weiss - Blanco - White - Bianco bl Bleu - Blau - Azul - Blue - Azzuro bl/bc Bleu/Blanc - Blau/Weiss - Azul/Blanco Blue/White - Azzuro/Bianco bl/n Bleu/Noir - Blau/Schwarz - Azul/Negro Blue/Black - Azzuro/Nero bl/s Bleu/Saumon - Blau/Salm - Azul/Asalmonado Blue/Salmon - Azzuro/Salmone g Gris - Grau - Gris - Grey - Grigi g/n Gris/Noir - Grau/Schwarz - Gris/Negro Grey/Black - Grigi/Nero j Jaune - Geld - Amarillo - Yellow - Giallo jvt Jaune vert - Geld grün - Amarillo verde Yellow green - Giallo verde m Marron - Braun - Bruño - Brown - Marrone m/n Marron/Noir - Braun/Schwarz - Bruño/Negro Brown/Black - Marrone/Nero			1	1	1	1	1	1	1	1	1										

2

Catalogue : 647000

CIRCUIT ELECTRIQUE  
STROMKREIS  
CIRCUITO ELECTRICO  
ELECTRIC CIRCUIT  
IMPIANTO ELETRICO

Qté-Menge-Cant-Qty-Q.ta

11 AA

1284

M

1- MH20-4T BUG. S2-E3 11-  
2- MH25-4T BUG. S2-E3 12-  
3- MSI 20T S2-E3 13-  
4- MSI 20T BUG. S2-E3 14-  
5- MSI 25T S2-E3 15-  
6- MSI 25T BUG. S2-E3 16-  
7- MSI 30T S2-E3 17-  
8- MSI 30T BUG. S2-E3 18-  
9- MSI 35T S2-E3 19-  
10- MSI 35T BUG. S2-E3 20-

Rep Hinw Fig Item Rif	Numéro Teil-Nr Numero Part-Nr Part-Nr	Désignation Bezeichnung Descripcion Description Descrizione	1	2	3	4	5	6	7	8	9	10	11	12	13	14	15	16	17	18	19	20	
		n Noir - Schwarz - Negro - Black - Nero n/bc Noir/Blanc - Schwarz/Weiss - Negro/Blanco Black/White - Nero/Bianco n/s Noir/Saumon - Schwarz/Salm - Negro/Asalmonado Black/Salmon - Nero/Salmone  o Orange - Goldgeld - Naranja - Orange - Arancione r Rouge - Rot - Rojo - Red - Rosso r/n Rouge/Noir - Rot/Schwarz - Rojo/Negro Red/Black - Rosso/Nero ro Rose - Rosenrot - Rosa - Pink - Rosa vi Violet - Violett - Violeta - Purple - Viola vt Vert - Grün - Verde - Green - Verde vt/n Vert/Noir - Grün/Schwarz - Verde/Negro Green/Black - Verde/Nero																					



# 11 AA 1285

## CIRCUIT ELECTRIQUE STROMKREIS CIRCUITO ELECTRICO ELECTRIC CIRCUIT IMPIANTO ELETRICO

### MH 20-4 T BUGGIE S2-E3 MH 25-4 T BUGGIE S2-E3

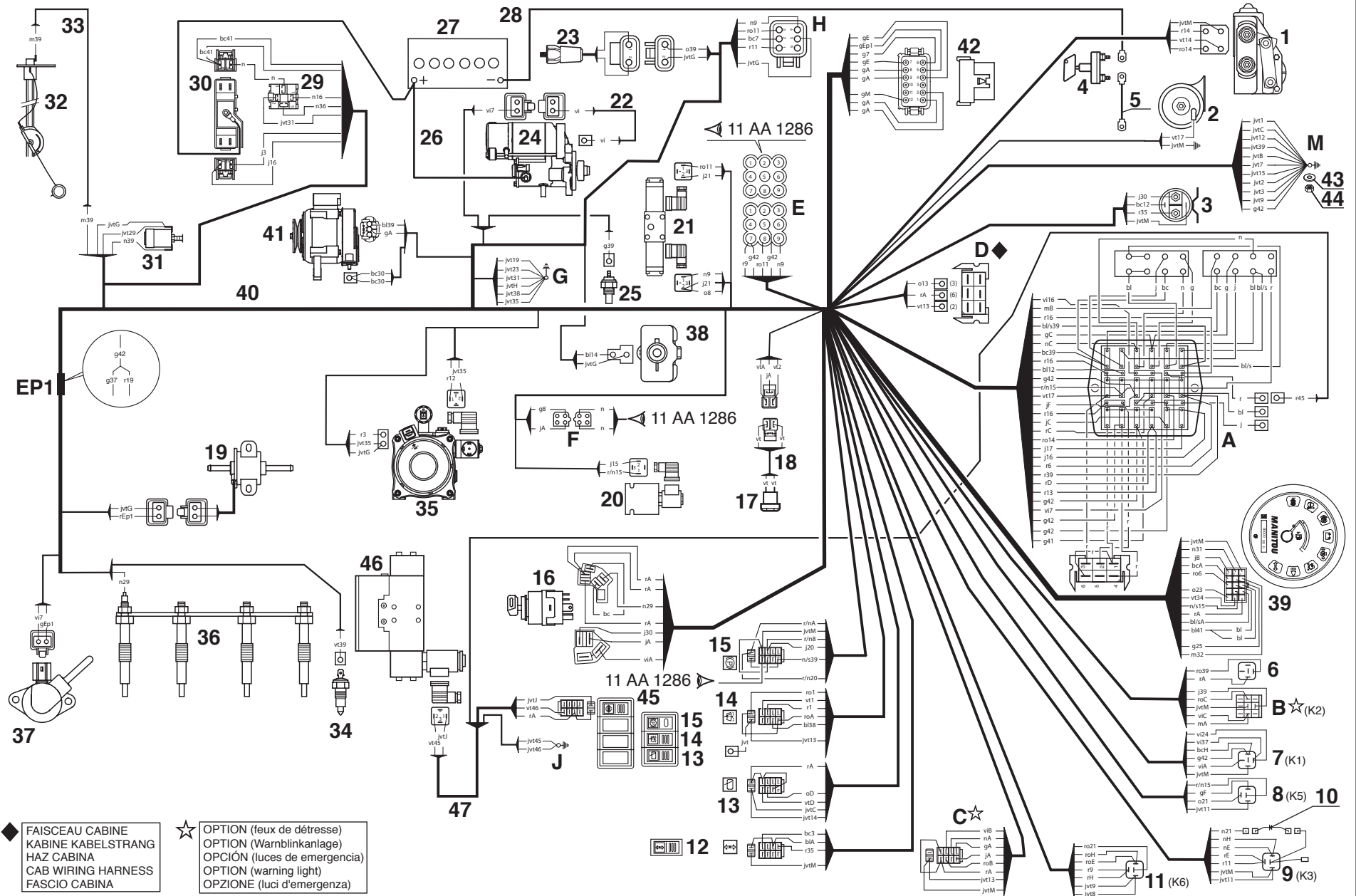

◆ FAISCEAU CABINE  
KABINE KABELSTRANG  
HAZ CABINA  
CAB WIRING HARNESS  
FASCIO CABINA

☆ OPTION (feux de détresse)  
OPTION (Warnblinkanlage)  
OPCIÓN (luces de emergencia)  
OPTION (warning light)  
OPZIONE (luci d'emergenza)

Catalogue : 647000

1	CIRCUIT ELECTRIQUE STROMKREIS CIRCUITO ELECTRICO ELECTRIC CIRCUIT IMPIANTO ELETRICO			Qté-Menge-Cant-Qty-Q.ta										11 AA		1285		M					
	Rep Hinw Fig Item Rif	Numéro Teil-Nr Numero Part-Nr Part-Nr	Désignation Bezeichnung Descripcion Description Descrizione	1	2	3	4	5	6	7	8	9	10	11	12	13	14		15	16	17	18	19
1	552672	Moteur d'essuie-glace Motor de limpiaparabrisas Motorino tergiacristallo	- Scheibenwischer motor - WindshIELD-wiper motor -			1	1	1	1	1	1	1	1										
2	20125	Avertisseur Bocina Signalatore acustico	- Hüpe - Horn -			1	1	1	1	1	1	1	1										
3	211012	Relais levage cabine Relé levantamiento cabina Centralina rele sollevamento cabina	- Relais Cab lifting - Cab lifting relay -			1	1	1	1	1	1	1	1										
4	223594	Coupe-batterie Corte batería Interruttore batteria	- Unterbrecher - Breaker circuit -			1	1	1	1	1	1	1	1										
5	247816	Câble Cable Cavo	- Kabel - Cable -			1	1	1	1	1	1	1	1										
6	176737	Vibrateur sonore Vibrador sonoro Buzzer	- Summer - Buzzer -			1	1	1	1	1	1	1	1										
7	231243	Relais Relé Centralina rele	- Relais - Relay -			1	1	1	1	1	1	1	1										
8	245700	Relais Relé Centralina rele	- Relais - Relay -			1	1	1	1	1	1	1	1										
9	225183	Relais Relé Centralina rele	- Relais - Relay -			1	1	1	1	1	1	1	1										
10	229040	Diode Diodo Diodo	- Diode - Diode -			1	1	1	1	1	1	1	1										
11	225183	Relais Relé Centralina rele	- Relais - Relay -			1	1	1	1	1	1	1	1										

+

Catalogue : 647000

2

CIRCUIT ELECTRIQUE  
STROMKREIS  
CIRCUITO ELECTRICO  
ELECTRIC CIRCUIT  
IMPIANTO ELETRICO

Qté-Menge-Cant-Qty-Q.ta

11 AA

1285

M

1- MH20-4T BUG. S2-E3 11-  
2- MH25-4T BUG. S2-E3 12-  
3- MSI 20T S2-E3 13-  
4- MSI 20T BUG. S2-E3 14-  
5- MSI 25T S2-E3 15-  
6- MSI 25T BUG. S2-E3 16-  
7- MSI 30T S2-E3 17-  
8- MSI 30T BUG. S2-E3 18-  
9- MSI 35T S2-E3 19-  
10- MSI 35T BUG. S2-E3 20-

Rep Hinw Fig Item Rif	Numéro Teil-Nr Numero Part-Nr Part-Nr	Désignation Bezeichnung Descripcion Description Descrizione	Qté-Menge-Cant-Qty-Q.ta																			
			1	2	3	4	5	6	7	8	9	10	11	12	13	14	15	16	17	18	19	20
12	246918	Interrupteur - Schalter Interruptor - Switch Interruttore -			1	1	1	1	1	1	1	1										
13	224765	Interrupteur essuie-glace arrière + toit Hinten scheibenwischer schalter + dach Interruptor limpiaparabrisas trasera + techo Rear windshield-wiper switch + roof Interruttore tergicristallo posteriore + tetto			1	1	1	1	1	1	1	1										
14	224766	Interrupteur essuie-glace + Lave glace Scheibenwischer schalter + Scheibenwashanlage Interruptor limpiaparabrisas + Lavaparabrisas Windshield-wiper switch + Windscren washer Interruttore tergicristallo + Lavacristalli			1	1	1	1	1	1	1	1										
15	236325	Interrupteur frein de parcage - Festellbremse schalter Interruptor freno de estacionamiento Parking bracke switch Interruttore freno -			1	1	1	1	1	1	1	1										
16	184817	Contacteur à clé - Zündschalter Contactor a llave - Ignition switch Interruttore chiave -			1	1	1	1	1	1	1	1										
17	202884	Contacteur avertisseur - Hüpe schalter Contactor bocina - Horn switch Contattore segnalatore acustico			1	1	1	1	1	1	1	1										
18	202701	Faisceau - Kabelbaum Haz - Wiring harness Fascio -			1	1	1	1	1	1	1	1										
19	272195	Pompe d'alimentation - Brennstoffpumpe Bomba de alimentación - Fuel pump Pompa alimentazione -			1	1	1	1	1	1	1	1										
20	202243	Electrovalve complète - Kompletter elektroventil Electroválvula completa - Complete electrovalve Electrovalvola completa -			1	1	1	1	1	1	1	1										
21	602063	Distributeur - Kommandosteuerventil Distribuidor - Valve bank Distributore -			1	1	1	1	1	1	1	1										

+



Catalogue : 647000

3

CIRCUIT ELECTRIQUE  
STROMKREIS  
CIRCUITO ELECTRICO  
ELECTRIC CIRCUIT  
IMPIANTO ELETRICO

Qté-Menge-Cant-Qty-Q.ta

11 AA

1285

M

1-	MH20-4T	BUG. S2-E3	11-
2-	MH25-4T	BUG. S2-E3	12-
3-	MSI 20T	S2-E3	13-
4-	MSI 20T	BUG. S2-E3	14-
5-	MSI 25T	S2-E3	15-
6-	MSI 25T	BUG. S2-E3	16-
7-	MSI 30T	S2-E3	17-
8-	MSI 30T	BUG. S2-E3	18-
9-	MSI 35T	S2-E3	19-
10-	MSI 35T	BUG. S2-E3	20-

Rep Hinw Fig Item Rif	Numéro Teil-Nr Numero Part-Nr Part-Nr	Désignation Bezeichnung Description Description	Qté-Menge-Cant-Qty-Q.ta																			
			1	2	3	4	5	6	7	8	9	10	11	12	13	14	15	16	17	18	19	20
22	274948	Faisceau - Kabelbaum Haz - Wiring harness Fascio -			1	1	1	1	1	1	1	1	1									
23	602099	Contacteur colmatage filtre à huile retour hydraulique Hydraulik ruckgang sfilter ablagerung schalter Contactor colmatado filtro de aceite retorno hidraulico Hydraulic return oil filter clogging switch Contattore intasamento filtro dell'olio ritorno idraulico			1	1	1	1	1	1	1	1										
24	748014	Démarrreur - Anlasser Arrancador - Starter motor Motorino avviamento -			1	1	1	1	1	1	1	1										
25	565345	Mano-contact pression huile moteur Ol motor druckschalter Mano contacto presión de aceite motor Engine oil pressure switch Interruttore pressione olio motore			1	1	1	1	1	1	1	1										
26	247817	Câble - Kabel Cable - Cable Cavo -			1	1	1	1	1	1	1	1										
27	247068	Batterie - Batterie Batería - Battery Batteria -			1	1	1	1	1	1	1	1										
28	250281	Câble - Kabel Cable - Cable Cavo -			1	1	1	1	1	1	1	1										
29	243482	Relais - Relais Relé - Relay Centralina rele -			1	1	1	1	1	1	1	1										
30	245292	Corps boîte à fusibles - Lichtsicherungsbüchse körper Cuerpo caja de fusibles - Fuses box body Corpo scatola valvole -			1	1	1	1	1	1	1	1										
31	224776	Indicateur colmatage filtre à air Luftfilter ablagerung schalter Contactor colmatado filtro de aire Air filter clogging switch Indicatore filtro aria -			1	1	1	1	1	1	1	1										

+

Catalogue : 647000

4

CIRCUIT ELECTRIQUE  
STROMKREIS  
CIRCUITO ELECTRICO  
ELECTRIC CIRCUIT  
IMPIANTO ELETRICO

Qté-Menge-Cant-Qty-Q.ta

11 AA

1285

M

- 1- MH20-4T BUG. S2-E3 11-
- 2- MH25-4T BUG. S2-E3 12-
- 3- MSI 20T S2-E3 13-
- 4- MSI 20T BUG. S2-E3 14-
- 5- MSI 25T S2-E3 15-
- 6- MSI 25T BUG. S2-E3 16-
- 7- MSI 30T S2-E3 17-
- 8- MSI 30T BUG. S2-E3 18-
- 9- MSI 35T S2-E3 19-
- 10- MSI 35T BUG. S2-E3 20-

Rep Hinw Fig Item Rif	Numéro Teil-Nr Numero Part-Nr Part-Nr	Désignation Bezeichnung Descripcion Description Descrizione	Qté-Menge-Cant-Qty-Q.ta																			
			1	2	3	4	5	6	7	8	9	10	11	12	13	14	15	16	17	18	19	20
32	216357	Jauge à carburant Galga de cargurante Livello carburante	- Kraftstoffmesser - Fuel gauge -			1	1	1	1	1	1	1	1									
33	217332	Faisceau Haz Fascio	- Kabelbaum - Wiring harness -			1	1	1	1	1	1	1	1									
34	706324	Sonde de température d'eau Sonda de temperatura de agua Sonda di temperatura acqua	- Wasser temperatur transmitt - Water temperature sensor -			1	1	1	1	1	1	1	1									
35	245718	Pompe relevage cabine Bomba levantamiento cabina Pompa sollevamento cabina	- Aufwinder kreis pumpe - Cab lifting pump -			1	1	1	1	1	1	1	1									
36	823616	Bougie de préchauffage Bujía de precalentamiento Termostarter	- Glühkerze - Heating plug -			4	4	4	4	4	4	4	4									
37	823584	Solénoïde Solenoid Solenoid Solenoid	- Solenoid - Solenoid -			1	1	1	1	1	1	1	1									
38	551450	Réservoir lave-glace Depósito lavaparabrissas Serbatoio di lavavetro	- Scheibenwaser behälter - Windshield-washer tank -			1	1	1	1	1	1	1	1									
39	252679	Tableau : Horamètre et voyants Enbrett : Stundenzähler und Leuchtzeichenbrett Tablero : Horometro y indicador Panel : Hour recorder and warning light Cruscotto : Tachimetro e segnale				1	1	1	1	1	1	1	1									
40	270452	Faisceau principal Haz principal Fascio principale	- Haupt Kabelbaum - Main wiring harness -			1	1	1	1	1	1	1	1									
41	747985	Alternateur Alternador Alternatore	- Wechselstromgenerator - Alternator -			1	1	1	1	1	1	1	1									
42	220408	Shunt Shunt Shunt	- Nebenschluss - Shunt -			1	1	1	1	1	1	1	1									

+

Catalogue : 647000

5	CIRCUIT ELECTRIQUE STROMKREIS CIRCUITO ELECTRICO ELECTRIC CIRCUIT IMPIANTO ELETRICO			Qté-Menge-Cant-Qty-Q.ta										11 AA		1285		M					
	Rep Hinw Fig Item Rif	Numéro Teil-Nr Numero Part-Nr Part-Nr	Désignation Bezeichnung Descripcion Description Descrizione	1	2	3	4	5	6	7	8	9	10	11	12	13	14		15	16	17	18	19
43	61674	Rondelle M 8 ZN Arandela Rondella	- Unterlegscheibe - Washer -			1	1	1	1	1	1	1	1										
44	58528	Ecrou H ,M 8 ZN Tuerca Dado	- Mutter - Nut -			1	1	1	1	1	1	1	1										
45	245365	Interrupteur Interruptor Interruttore	- Schalter - Switch -			1	1	1	1	1	1	1	1										
46	247704	Bloc d'alimentation droit Bloque de alimentación derecho Blocco alimentazione destro	- Recht Zuschiebungblock - R.H. feed block -			1	1	1	1	1	1	1	1										
47	248166	Faisceau Haz Fascio	- Kabelbaum - Wiring harness -			1	1	1	1	1	1	1	1										
		Couleurs :																					
		bc Blanc - Weiss - Blanco - White - Bianco																					
		bl Bleu - Blau - Azul - Blue - Azzuro																					
		bl/bc Bleu/Blanc - Blau/Weiss - Azul/Blanco - Blue/White Blue/White - Azzuro/Bianco																					
		bl/n Bleu/Noir - Blau/Schwarz - Azul/Negro - Blue/Black Blue/Black - Azzuro/Nero																					
		bl/s Bleu/Saumon - Blau/Salm - Azul/Asalmonado Blue/Salmon - Azzuro/Salmone																					
		g Gris - Grau - Gris - Grey - Grigi																					
		g/n Gris/Noir - Grau/Schwarz - Gris/Negro Grey/Black - Grigi/Nero																					
		j Jaune - Geld - Amarillo - Yellow - Giallo																					
		jvt Jaune vert - Geld grün - Amarillo verde Yellow green - Giallo verde																					
		m Marron - Braun - Bruño - Brown - Marrone																					
		m/n Marron/Noir - Braun/Schwarz - Bruño/Negro Brown/Black - Marrone/Nero																					
		n Noir - Schwarz - Negro - Black - Nero																					
		n/bc Noir/Blanc - Schwarz/Weiss - Negro/Blanco Black/White - Nero/Bianco																					
		n/s Noir/Saumon - Schwarz/Salm - Negro/Asalmonado																					

Catalogue : 647000

6

CIRCUIT ELECTRIQUE  
STROMKREIS  
CIRCUITO ELECTRICO  
ELECTRIC CIRCUIT  
IMPIANTO ELETRICO

Qté-Menge-Cant-Qty-Q.ta

11 AA

1285

M

Rep Hinw Fig Item Rif	Numéro Teil-Nr Numero Part-Nr Part-Nr	Désignation Bezeichnung Descripcion Description Descrizione	11 AA 1285																			
			1	2	3	4	5	6	7	8	9	10	11	12	13	14	15	16	17	18	19	20
		Black/Salmon - Nero/Salmone o Orange - Goldgeld - Naranja - Orange - Arancione r Rouge - Rot - Rojo - Red - Rosso r/n Rouge/Noir - Rot/Schwarz - Rojo/Negro Red/Black - Rosso/Nero ro Rose - Rosenrot - Rosa - Pink - Rosa vi Violet - Violett - Violeta - Purple - Viola vt Vert - Grün - Verde - Green - Verde vt/n Vert/Noir - Grün/Schwarz - Verde/Negro Green/Black - Verde/Nero																				



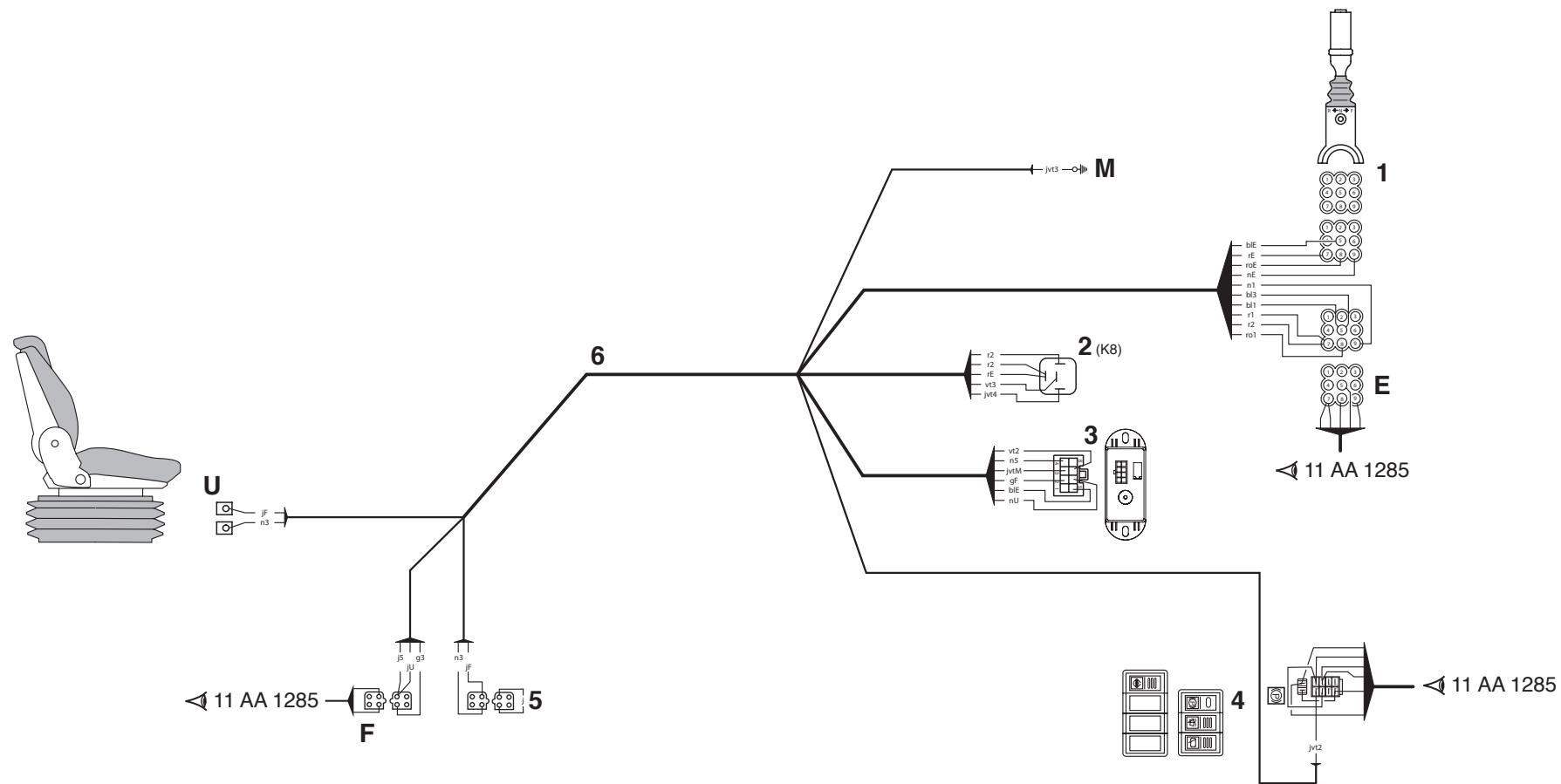

Catalogue : 647000

1	CIRCUIT ELECTRIQUE STROMKREIS CIRCUITO ELECTRICO ELECTRIC CIRCUIT IMPIANTO ELETRICO			Qté-Menge-Cant-Qty-Q.ta																11 AA	1286	M		
	Rep Hinw Fig Item Rif	Numéro Teil-Nr Numero Part-Nr Part-Nr	Désignation Bezeichnung Descripcion Description Descrizione	1	2	3	4	5	6	7	8	9	10	11	12	13	14	15	16	17	18	19	20	
1	234956	Inverseur de marche Inversor de marcha Invertitore di marcia	- Umsteuergetriebe - Reversing gears -	1	1																			
2	225183	Relais Relé Centralina rele	- Relais - Relay -	1	1																			
3	252261	Module coupure transmission Módulo corte transmisión Modulo di arresto trasmissione-	- Getriebe trenn modul - Transmission cut-off modulus -	1	1																			
4	236325	Interrupteur frein de parcage Interruptor freno de estacionamiento Parking bracke switch Interruttore freno	- Festellbremse schalter - - -	1	1																			
5	204859	Borne de jonction Borne de union Morsetto di collegamento	- Verbindung anschlusspol - Coupling terminal -	1	1																			
6	252737	Faisceau Haz Fascio  Couleurs :	- Kabelbaum - Wiring harness -  bc Blanc - Weiss - Blanco - White - Bianco bl Bleu - Blau - Azul - Blue - Azzuro bl/bc Bleu/Blanc - Blau/Weiss - Azul/Blanco Blue/White - Azzuro/Bianco bl/n Bleu/Noir - Blau/Schwarz - Azul/Negro Blue/Black - Azzuro/Nero bl/s Bleu/Saumon - Blau/Salm - Azul/Asalmonado Blue/Salmon - Azzuro/Salmone g Gris - Grau - Gris - Grey - Grigi g/n Gris/Noir - Grau/Schwarz - Gris/Negro Grey/Black - Grigi/Nero j Jaune - Geld - Amarillo - Yellow - Giallo jvt Jaune vert - Geld grün - Amarillo verde Yellow green - Giallo verde m Marron - Braun - Bruño - Brown - Marrone m/n Marron/Noir - Braun/Schwarz - Bruño/Negro Brown/Black - Marrone/Nero	1	1																			

+

2

Catalogue : 647000

CIRCUIT ELECTRIQUE  
STROMKREIS  
CIRCUITO ELECTRICO  
ELECTRIC CIRCUIT  
IMPIANTO ELETRICO

Qté-Menge-Cant-Qty-Q.ta

11 AA

1286

M

1- MH20-4T BUG. S2-E3 11-  
2- MH25-4T BUG. S2-E3 12-  
3- MSI 20T S2-E3 13-  
4- MSI 20T BUG. S2-E3 14-  
5- MSI 25T S2-E3 15-  
6- MSI 25T BUG. S2-E3 16-  
7- MSI 30T S2-E3 17-  
8- MSI 30T BUG. S2-E3 18-  
9- MSI 35T S2-E3 19-  
10- MSI 35T BUG. S2-E3 20-

Rep Hinw Fig Item Rif	Numéro Teil-Nr Numero Part-Nr Part-Nr	Désignation Bezeichnung Descripcion Description Descrizione	1	2	3	4	5	6	7	8	9	10	11	12	13	14	15	16	17	18	19	20	
		n Noir - Schwarz - Negro - Black - Nero n/bc Noir/Blanc - Schwarz/Weiss - Negro/Blanco Black/White - Nero/Bianco n/s Noir/Saumon - Schwarz/Salm - Negro/Asalmonado Black/Salmon - Nero/Salmone  o Orange - Goldgeld - Naranja - Orange - Arancione r Rouge - Rot - Rojo - Red - Rosso r/n Rouge/Noir - Rot/Schwarz - Rojo/Negro Red/Black - Rosso/Nero ro Rose - Rosenrot - Rosa - Pink - Rosa vi Violet - Violett - Violeta - Purple - Viola vt Vert - Grün - Verde - Green - Verde vt/n Vert/Noir - Grün/Schwarz - Verde/Negro Green/Black - Verde/Nero																					





# 11 CB 885

ELECTRICITE (Détails)  
 ELEKTIZITÄT (Einzelheiten)  
 ELECTRICIDAD (Detalles)  
 ELECTRICITY (Details)  
 ELETTRICO (Dettaglio)

MH 20-4 T BUGGIE S2-E3  
 MH 25-4 T BUGGIE S2-E3  
 MSI 20 / 25 / 30 / 35 T S2-E3  
 MSI 20 / 25 / 30 / 35 T BUGGIE S2-E3

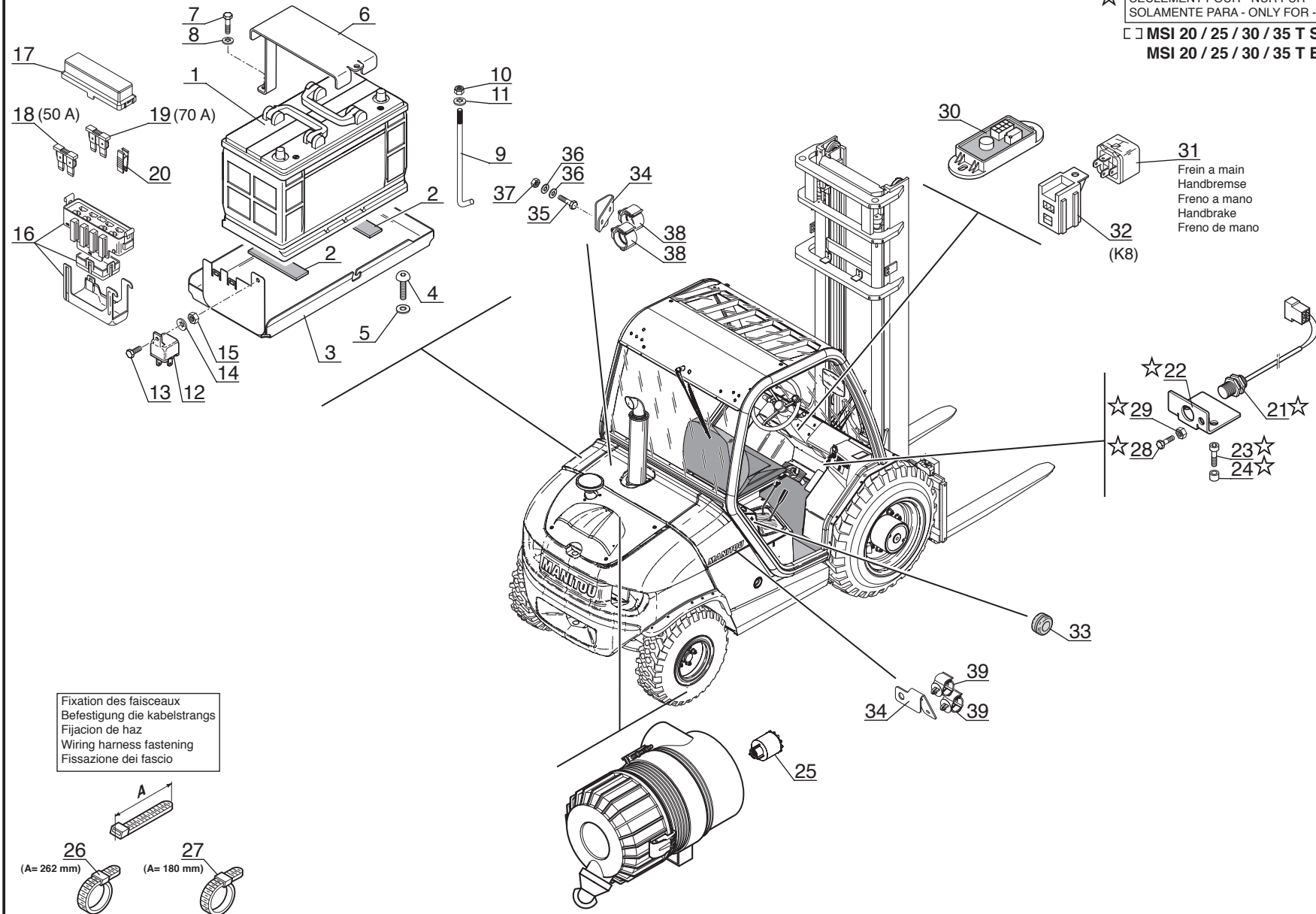

☆ SEULEMENT POUR - NUR FÜR  
 SOLAMENTE PARA - ONLY FOR - SOLO PER

☐ MSI 20 / 25 / 30 / 35 T S2-E3  
 MSI 20 / 25 / 30 / 35 T BUGGIE S2-E3

31  
 Frein a main  
 Handbremse  
 Freno a mano  
 Handbrake  
 Freno de mano

Fixation des faisceaux  
 Befestigung die kabelstrangs  
 Fijacion de haz  
 Wiring harness fastening  
 Fissazione dei fascio

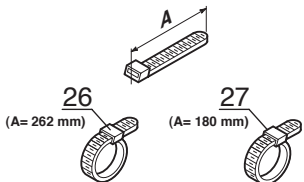

Catalogue : 647000

1	ELECTRICITE (Détails) ELEKTRIZITÄT (Einzelteile) ELECTRICIDAD (Detalles) ELECTRICITY (Details) ELETRICO (Dettaglio)			Qté-Menge-Cant-Qty-Q.ta										11 CB		885		M					
	Rep Hinw Fig Item Rif	Numéro Teil-Nr Numero Part-Nr Part-Nr	Désignation Bezeichnung Descripcion Description Descrizione	1	2	3	4	5	6	7	8	9	10	11	12	13	14	15	16	17	18	19	20
1	247068	Batterie Batería Batteria	- Batterie - Battery -	1	1	1	1	1	1	1	1	1	1										
2	217331	Bande caoutchouc Cinta goma Gomma	- Gummireifen - Rubber strip -	2	2	2	2	2	2	2	2	2	2										
3	247210	Bac à batterie Cubeta de batería Serbatoio batteria	- Batteriekasten - Battery box -	1	1	1	1	1	1	1	1	1	1										
4	202731	Vis CBHc,M 8- 16-10.9-ZN8/NOIR- Tornillo Vite	- Schraube - Screw -	4	4	4	4	4	4	4	4	4	4										
5	61674	Rondelle M 8 ZN Arandela Rondella	- Unterlegscheibe - Washer -	4	4	4	4	4	4	4	4	4	4										
6	247209	Bride de fixation Brida de fijación Flangia di fissaggio	- Befestigung Klammer - Fastening flange -	1	1	1	1	1	1	1	1	1	1										
7	58526	Vis H,M 6- 40-8.8-ZN5/C Tornillo Vite	- Schraube - Screw -	1	1	1	1	1	1	1	1	1	1										
8	174132	Rondelle JZC 6 CAD.BICH Arandela Rondella	- Unterlegscheibe - Washer -	1	1	1	1	1	1	1	1	1	1										
9	182781	Tige filetée Varilla fileteada Stelo filettato	- Schraubenspindel - Screwed spindle -	1	1	1	1	1	1	1	1	1	1										
10	162229	Ecrou H,FR M 6 C 8 ZN..C Tuerca Dado	- Mutter - Nut -	1	1	1	1	1	1	1	1	1	1										
11	174132	Rondelle JZC 6 CAD.BICH Arandela Rondella	- Unterlegscheibe - Washer -	1	1	1	1	1	1	1	1	1	1										

+

Catalogue : 647000

2

ELECTRICITE (Détails)  
 ELEKTRIZITÄT (Einzelteile)  
 ELECTRICIDAD (Detalles)  
 ELECTRICITY (Details)  
 ELETRICO (Dettaglio)

Qté-Menge-Cant-Qty-Q.ta

11 CB

885

M

1-	MH20-4T	BUG. S2-E3	11-
2-	MH25-4T	BUG. S2-E3	12-
3-	MSI 20T	S2-E3	13-
4-	MSI 20T	BUG. S2-E3	14-
5-	MSI 25T	S2-E3	15-
6-	MSI 25T	BUG. S2-E3	16-
7-	MSI 30T	S2-E3	17-
8-	MSI 30T	BUG. S2-E3	18-
9-	MSI 35T	S2-E3	19-
10-	MSI 35T	BUG. S2-E3	20-

Rep Hinw Fig Item Rif	Numéro Teil-Nr Numero Part-Nr Part-Nr	Désignation Bezeichnung Descripcion Description Descrizione	1	2	3	4	5	6	7	8	9	10	11	12	13	14	15	16	17	18	19	20
12	243482	Relais Relé Centralina rele - Relais - Relay -	1	1	1	1	1	1	1	1	1	1										
13	46668	Vis H,M 6- 20-8.8-ZN5/C Tornillo Vite - Schraube - Screw -	1	1	1	1	1	1	1	1	1	1										
14	174132	Rondelle JZC 6 CAD.BICH Arandela Rondella - Unterlegscheibe - Washer -	1	1	1	1	1	1	1	1	1	1										
15	25714	Ecrou H ,M 6 ZN Tuerca Dado - Mutter - Nut -	1	1	1	1	1	1	1	1	1	1										
16	245292	Corps boîte à fusibles Cuerpo caja de fusibles Corpo scatola valvole - Lichtsicherungsbüchse körper - Fuses box body -	1	1	1	1	1	1	1	1	1	1										
17	245293	Couvercle Tapadera Coperchio - Deckel - Cover -	1	1	1	1	1	1	1	1	1	1										
18	247075	Fusible ( 50 A) Fusible Fusibile - Lichtsicherung - Fuse -	X	X	X	X	X	X	X	X	X	X										
19	247922	Fusible ( 70 A) Fusible Fusibile - Lichtsicherung - Fuse -	X	X	X	X	X	X	X	X	X	X										
20	245295	Pince à fusible Pinza a fusible Pinza fusibili - Lichtsicherung Kneifen - Fuse pincers -	1	1	1	1	1	1	1	1	1	1										
21	236963	Détecteur de proximité Detector Segnalatore - Detektor - Detector -			1	1	1	1	1	1	1	1										
22	229792	Support détecteur Soporte detector Supporto segnalatore - Detektor träger - Detector bracket -			1	1	1	1	1	1	1	1										

+

Catalogue : 647000

3	ELECTRICITE (Détails) ELEKTRIZITÄT (Einzelteile) ELECTRICIDAD (Detalles) ELECTRICITY (Details) ELETRICO (Dettaglio)			Qté-Menge-Cant-Qty-Q.ta											11 CB		885		M				
	Rep Hinw Fig Item Rif	Numéro Teil-Nr Numero Part-Nr Part-Nr	Désignation Bezeichnung Descripcion Description Descrizione	1	2	3	4	5	6	7	8	9	10	11	12	13	14	15	16	17	18	19	20
23	60845	Vis CHc,M 8- 30-8.8-ZN8/C Tornillo Vite	- Schraube - Screw -			2	2	2	2	2	2	2	2										
24	219567	Entretoise Separador Distanziale	- Querstrebe - Spacer -			2	2	2	2	2	2	2	2										
25	224776	Indicateur colmatage filtre à air Luftfilter ablagerung schalter Contacteur colmatado filtro de aire Air filter clogging switch Indicatore filtro aria	-	1	1	1	1	1	1	1	1	1	1										
26	21980	Collier Abrazadera Fascetta	- Spannschelle - Clamp -	3	3	3	3	3	3	3	3	3	3										
27	164856	Collier Abrazadera Fascetta	- Spannschelle - Clamp -	11	11	11	11	11	11	11	11	11	11										
28	54305	Vis H,M 6- 30-8.8-ZN5/C Tornillo Vite	- Schraube - Screw -			1	1	1	1	1	1	1	1										
29	29477	Ecrou Hm, M 6 zingué Tuerca Dado	- Mutter - Nut -			1	1	1	1	1	1	1	1										
30	252261	Module coupure transmission Módulo corte transmisión Modulo di arresto trasmissione-	- Getriebe trenn modul - Transmission cut-off modulus	1	1	1	1	1	1	1	1	1	1										
31	225183	Relais Relé Centralina rele	- Relais - Relay -	1	1	1	1	1	1	1	1	1	1										
32	603293	Support relais Soporte relé Supporto relé	- Relais träger - Relay bracket -	1	1	1	1	1	1	1	1	1	1										
33	19994	Passe-fil Arandela de gaucho Passo-filo	- Gummischeibe - Cable grommet -	1	1	1	1	1	1	1	1	1	1										

Catalogue : 647000

4

ELECTRICITE (Détails)  
 ELEKTRIZITÄT (Einzelteile)  
 ELECTRICIDAD (Detalles)  
 ELECTRICITY (Details)  
 ELETRICO (Dettaglio)

Qté-Menge-Cant-Qty-Q.ta

11 CB

885

M

1-	MH20-4T	BUG. S2-E3	11-
2-	MH25-4T	BUG. S2-E3	12-
3-	MSI 20T	S2-E3	13-
4-	MSI 20T	BUG. S2-E3	14-
5-	MSI 25T	S2-E3	15-
6-	MSI 25T	BUG. S2-E3	16-
7-	MSI 30T	S2-E3	17-
8-	MSI 30T	BUG. S2-E3	18-
9-	MSI 35T	S2-E3	19-
10-	MSI 35T	BUG. S2-E3	20-

Rep Hinw Fig Item Rif	Numéro Teil-Nr Numero Part-Nr Part-Nr	Désignation Bezeichnung Descripcion Description Descrizione	Qté-Menge-Cant-Qty-Q.ta																			
			1	2	3	4	5	6	7	8	9	10	11	12	13	14	15	16	17	18	19	20
34	270975	Patte de fixation Brida de fijación Flangia di fissaggio - Befestigung auge - Fastening lug -	2	2	2	2	2	2	2	2	2	2										
35	46668	Vis H,M 6- 20-8.8-ZN5/C Tornillo Vite - Schraube - Screw -	1	1	1	1	1	1	1	1	1	1	1									
36	29469	Rondelle M 6 ZN Arandela Rondella - Unterlegscheibe - Washer -	2	2	2	2	2	2	2	2	2	2										
37	25714	Ecrou H ,M 6 ZN Tuerca Dado - Mutter - Nut -	1	1	1	1	1	1	1	1	1	1										
38	260477	Collier Abrazadera Fascetta - Spannschelle - Clamp -	2	2	2	2	2	2	2	2	2	2										
39	260475	Collier Abrazadera Fascetta - Spannschelle - Clamp -	2	2	2	2	2	2	2	2	2	2										



# 11 CC 218

ELECTRICITE (Poste de conduite)  
 ELEKTRIZITÄT (Fahrerstand)  
 ELECTRICIDAD (Puesto del conductor)  
 ELECTRICITY (Cab structure)  
 ELETTRICO (Posto di pilotaggio)

MH 20-4 T BUGGIE S2-E3  
 MH 25-4 T BUGGIE S2-E3  
 MSI 20 / 25 / 30 / 35 T S2-E3  
 MSI 20 / 25 / 30 / 35 T BUGGIE S2-E3

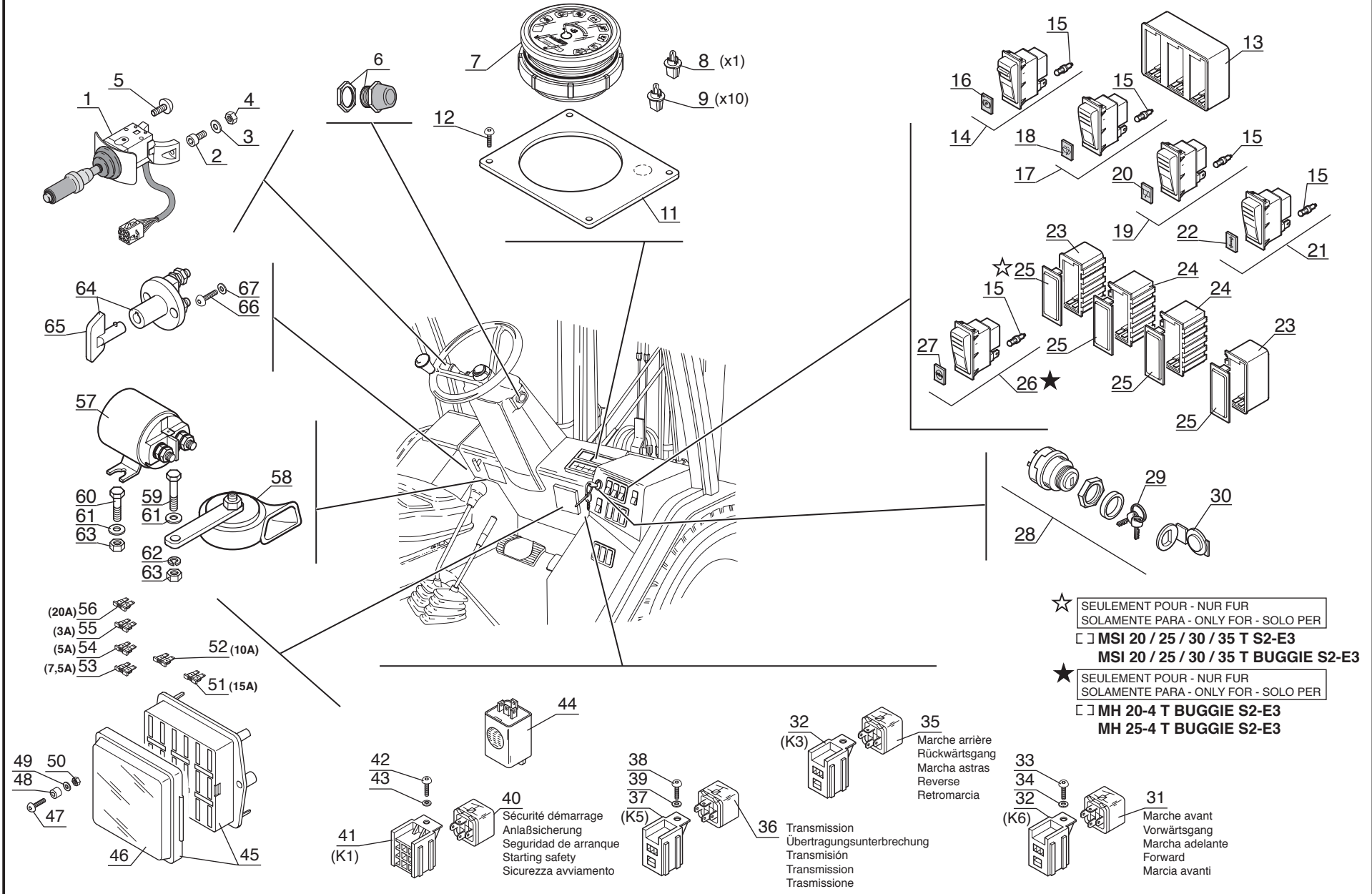



Catalogue : 647000

Qté-Menge-Cant-Qty-Q.ta	11 CC	218
1- MH20-4T BUG. S2-E3	11-	
2- MH25-4T BUG. S2-E3	12-	
3- MSI 20T S2-E3	13-	
4- MSI 20T BUG. S2-E3	14-	
5- MSI 25T S2-E3	15-	
6- MSI 25T BUG. S2-E3	16-	
7- MSI 30T S2-E3	17-	
8- MSI 30T BUG. S2-E3	18-	
9- MSI 35T S2-E3	19-	
10- MSI 35T BUG. S2-E3	20-	

M

1	ELECTRICITE (Poste de conduite) ELEKTRIZITÄT (Fahrerstand) ELECTRICIDAD (Puesto del conductor) ELECTRICITY (Cab structure) ELETRICO (Posto di pilotaggio)		
Rep Hinw Fig Item Rif	Numéro Teil-Nr Numero Part-Nr Part-Nr	Désignation Bezeichnung Descripcion Description Descrizione	
1	234956	Inverseur de marche - Umsteuergetriebe Inversor de marcha - Reversing gears Invertitore di marcia -	
2	5323	Vis - Schraube Tornillo - Screw Vite -	
3	28959	Rondelle M 5 ZN - Unterlegscheibe Arandela - Washer Rondella -	
4	54232	Ecrou H ,M 5 ZN - Mutter Tuerca - Nut Dado -	
5	230853	Vis CBHc,M 5- 8-10.9-ZN5/NOIR- Schraube Tornillo - Screw Vite -	
6	202884	Contacteur avertisseur - Hüpe schalter Contactor bocina - Horn switch Contattore segnalatore acustico	
7	252679	Tableau : Horamètre et voyants Enbrett : Stundenzähler und Leuchtzeichenenbrett Tablero : Horametro y indicador Panel : Hour recorder and warning light Cruscotto : Tachimetro e segnale	
8	552485	Ampoule avec support (vert) - Birne mit träger (grün) Bombilla con soporte (verde) - Bulb with bracket (green) Lampadina con supporto (verde)-	
9	552484	Ampoule avec support (noir) - Birne mit träger (schwarz) Bombilla con soporte (negro) - Bulb with bracket (black) Lampadina con supporto (nero) -	
11	247759	Support - Träger Soporte - Bracket Supporto -	
12	79533	Vis CBHc,M 5- 10-10.9-ZN5/NOIR- Schraube Tornillo - Screw Vite -	

1	2	3	4	5	6	7	8	9	10	11	12	13	14	15	16	17	18	19	20
1	1	1	1	1	1	1	1	1	1										
2	2	2	2	2	2	2	2	2	2										
3	2	2	2	2	2	2	2	2	2										
4	2	2	2	2	2	2	2	2	2										
5	1	1	1	1	1	1	1	1	1										
6	1	1	1	1	1	1	1	1	1										
7	1	1	1	1	1	1	1	1	1										
8	1	1	1	1	1	1	1	1	1										
9	10	10	10	10	10	10	10	10	10										
11	1	1	1	1	1	1	1	1	1										
12	4	4	4	4	4	4	4	4	4										

+

Catalogue : 647000

2

ELECTRICITE (Poste de conduite)  
 ELEKTRIZITÄT (Fahrerstand)  
 ELECTRICIDAD (Puesto del conductor)  
 ELECTRICITY (Cab structure)  
 ELETRICO (Posto di pilotaggio)

Qté-Menge-Cant-Qty-Q.ta

11 CC

218

M

1-	MH20-4T	BUG. S2-E3	11-
2-	MH25-4T	BUG. S2-E3	12-
3-	MSI 20T	S2-E3	13-
4-	MSI 20T	BUG. S2-E3	14-
5-	MSI 25T	S2-E3	15-
6-	MSI 25T	BUG. S2-E3	16-
7-	MSI 30T	S2-E3	17-
8-	MSI 30T	BUG. S2-E3	18-
9-	MSI 35T	S2-E3	19-
10-	MSI 35T	BUG. S2-E3	20-

Rep Hinw Fig Item Rif	Numéro Teil-Nr Numero Part-Nr Part-Nr	Désignation Bezeichnung Descripcion Description Descrizione	1	2	3	4	5	6	7	8	9	10	11	12	13	14	15	16	17	18	19	20
13	232116	Support interrupteur - Schalter träger Soporte interruptor - Switch bracket Supporto interruttore -	1	1	1	1	1	1	1	1	1	1										
14	236325	Interrupteur frein de parcage - Feststellbremse schalter Interruptor freno de estacionamiento Parking bracke switch Interruttore freno -	1	1	1	1	1	1	1	1	1	1										
15	170836	Ampoule - Birne Bombilla - Bulb Lampadina -	X	X	X	X	X	X	X	X	X	X										
16	603720	Lentille - Linse Lente - Lens Vetrino -	1	1	1	1	1	1	1	1	1	1										
17	224766	Interrupteur essuie-glace + Lave glace Scheibenwisher schalter + Scheibenwshanlage Interruptor limpiaparabrisas + Lavaparabrisas Windshield-wiper switch + Windscren washer Interruttore tergicristallo + Lavacristalli	1	1	1	1	1	1	1	1	1	1										
18	563798	Lentille - Linse Lente - Lens Vetrino -	1	1	1	1	1	1	1	1	1	1										
19	224765	Interrupteur essuie-glace arrière + toit Hinten scheibenwischer schalter + dach Interruptor limpiaparabrisas trasera + techo Rear windshield-wiper switch + roof Interruttore tergicristallo posteriore + tetto	1	1	1	1	1	1	1	1	1	1										
20	563799	Lentille - Linse Lente - Lens Vetrino -	1	1	1	1	1	1	1	1	1	1										
21	246918	Interrupteur - Schalter Interruptor - Switch Interruttore -	1	1	1	1	1	1	1	1	1	1										
22	702943	Lentille - Linse Lente - Lens Vetrino -	1	1	1	1	1	1	1	1	1	1										

+

Catalogue : 647000

3

ELECTRICITE (Poste de conduite)  
 ELEKTRIZITÄT (Fahrerstand)  
 ELECTRICIDAD (Puesto del conductor)  
 ELECTRICITY (Cab structure)  
 ELETRICO (Posto di pilotaggio)

Qté-Menge-Cant-Qty-Q.ta

11 CC

218

M

1-	MH20-4T	BUG. S2-E3	11-
2-	MH25-4T	BUG. S2-E3	12-
3-	MSI 20T	S2-E3	13-
4-	MSI 20T	BUG. S2-E3	14-
5-	MSI 25T	S2-E3	15-
6-	MSI 25T	BUG. S2-E3	16-
7-	MSI 30T	S2-E3	17-
8-	MSI 30T	BUG. S2-E3	18-
9-	MSI 35T	S2-E3	19-
10-	MSI 35T	BUG. S2-E3	20-

Rep Hinw Fig Item Rif	Numéro Teil-Nr Numero Part-Nr Part-Nr	Désignation Bezeichnung Descripcion Description Descrizione	1	2	3	4	5	6	7	8	9	10	11	12	13	14	15	16	17	18	19	20	
23	224774	Support interrupteur Soporte interruptor Supporto interruttore - Schalter träger - Switch bracket -	2	2	2	2	2	2	2	2	2	2											
24	224773	Support interrupteur Soporte interruptor Supporto interruttore - Schalter träger - Switch bracket -	2	2	2	2	2	2	2	2	2	2											
25	224775	Obturateur Obturador Tappo - Stopfen - Plug -	3	3	4	4	4	4	4	4	4	4											
26	245365	Interrupteur Interruptor Interruttore - Schalter - Switch -	1	1																			
27	603301	Lentille Lente Vetrino - Linse - Lens -	1	1																			
28	184817	Contacteur à clé Contactor a llave Interruttore chiave - Zündschalter - Ignition switch -	1	1	1	1	1	1	1	1	1	1											
29	184818	Clé de contact Llave de contact Chiave - Schlüssel - Key -	2	2	2	2	2	2	2	2	2	2											
30	77522	Capuchon Capuchón Cappuccio - Kappe - Cap -	1	1	1	1	1	1	1	1	1	1											
31	225183	Relais Relé Centralina rele - Relais - Relay -	1	1	1	1	1	1	1	1	1	1											
32	603293	Support relais Soporte relé Supporto relé - Relais träger - Relay bracket -	2	2	2	2	2	2	2	2	2	2											
33	184036	Vis CBHc,M 5- 16-10.9-ZN5/NOIR- Tornillo Vite - Schraube - Screw -	1	1	1	1	1	1	1	1	1	1											

+

Catalogue : 647000

4

ELECTRICITE (Poste de conduite)  
 ELEKTRIZITÄT (Fahrerstand)  
 ELECTRICIDAD (Puesto del conductor)  
 ELECTRICITY (Cab structure)  
 ELETRICO (Posto di pilotaggio)

Qté-Menge-Cant-Qty-Q.ta

11 CC

218

M

1-	MH20-4T	BUG. S2-E3	11-
2-	MH25-4T	BUG. S2-E3	12-
3-	MSI 20T	S2-E3	13-
4-	MSI 20T	BUG. S2-E3	14-
5-	MSI 25T	S2-E3	15-
6-	MSI 25T	BUG. S2-E3	16-
7-	MSI 30T	S2-E3	17-
8-	MSI 30T	BUG. S2-E3	18-
9-	MSI 35T	S2-E3	19-
10-	MSI 35T	BUG. S2-E3	20-

Rep Hinw Fig Item Rif	Numéro Teil-Nr Numero Part-Nr Part-Nr	Désignation Bezeichnung Descripcion Description Descrizione	1	2	3	4	5	6	7	8	9	10	11	12	13	14	15	16	17	18	19	20	
34	28959	Rondelle M 5 ZN Arandela Rondella - Unterlegscheibe - Washer -	1	1	1	1	1	1	1	1	1	1											
35	225183	Relais Relé Centralina rele - Relais - Relay -	1	1	1	1	1	1	1	1	1	1											
36	245700	Relais Relé Centralina rele - Relais - Relay -	1	1	1	1	1	1	1	1	1	1											
37	603293	Support relais Soporte relé Supporto relé - Relais Träger - Relay bracket -	1	1	1	1	1	1	1	1	1	1											
38	184036	Vis CBHc,M 5- 16-10.9-ZN5/NOIR- Tornillo Vite - Schraube - Screw -	1	1	1	1	1	1	1	1	1	1											
39	28959	Rondelle M 5 ZN Arandela Rondella - Unterlegscheibe - Washer -	1	1	1	1	1	1	1	1	1	1											
40	231243	Relais Relé Centralina rele - Relais - Relay -	1	1	1	1	1	1	1	1	1	1											
41	602632	Adaptateur 9 Pôles Adaptador Adattatore - Verbindung - Adaptor -	1	1	1	1	1	1	1	1	1	1											
42	79533	Vis CBHc,M 5- 10-10.9-ZN5/NOIR- Tornillo Vite - Schraube - Screw -	1	1	1	1	1	1	1	1	1	1											
43	192310	Rondelle JZC 5 CAD.BICH Arandela Rondella - Unterlegscheibe - Washer -	1	1	1	1	1	1	1	1	1	1											
44	176737	Vibrateur sonore Vibrador sonoro Buzzer - Summer - Buzzer -	1	1	1	1	1	1	1	1	1	1											

+

Catalogue : 647000

5

ELECTRICITE (Poste de conduite)  
 ELEKTRIZITÄT (Fahrerstand)  
 ELECTRICIDAD (Puesto del conductor)  
 ELECTRICITY (Cab structure)  
 ELETRICO (Posto di pilotaggio)

Qté-Menge-Cant-Qty-Q.ta

11 CC

218

M

1-	MH20-4T	BUG. S2-E3	11-
2-	MH25-4T	BUG. S2-E3	12-
3-	MSI 20T	S2-E3	13-
4-	MSI 20T	BUG. S2-E3	14-
5-	MSI 25T	S2-E3	15-
6-	MSI 25T	BUG. S2-E3	16-
7-	MSI 30T	S2-E3	17-
8-	MSI 30T	BUG. S2-E3	18-
9-	MSI 35T	S2-E3	19-
10-	MSI 35T	BUG. S2-E3	20-

Rep Hinw Fig Item Rif	Numéro Teil-Nr Numero Part-Nr Part-Nr	Désignation Bezeichnung Descripcion Description Descrizione	1	2	3	4	5	6	7	8	9	10	11	12	13	14	15	16	17	18	19	20	
45	562044	Boîte à fusibles Caja de fusibles Scatola valvole - Lichtsicherungsbüchse - Fuses box -	1	1	1	1	1	1	1	1	1	1											
46	561322	Couvercle Tapadera Coperchio - Deckel - Cover -	1	1	1	1	1	1	1	1	1	1											
47	214099	Vis CBHc,M 6- 40-10.9-ZN5/NOIR- Tornillo Vite - Schraube - Screw -	2	2	2	2	2	2	2	2	2	2											
48	214098	Tube Tubo Tubo - Rohr - Tube -	2	2	2	2	2	2	2	2	2	2											
49	29469	Rondelle M 6 ZN Arandela Rondella - Unterlegscheibe - Washer -	2	2	2	2	2	2	2	2	2	2											
50	25714	Ecrou H ,M 6 ZN Tuerca Dado - Mutter - Nut -	2	2	2	2	2	2	2	2	2	2											
51	205805	Fusible ( 15 A) Fusible Fusibile - Lichtsicherung - Fuse -	X	X	X	X	X	X	X	X	X	X											
52	177739	Fusible ( 10 A) Fusible Fusibile - Lichtsicherung - Fuse -	X	X	X	X	X	X	X	X	X	X											
53	173491	Fusible ( 7,5 A) Fusible Fusibile - Lichtsicherung - Fuse -	X	X	X	X	X	X	X	X	X	X											
54	207007	Fusible ( 5 A) Fusible Fusibile - Lichtsicherung - Fuse -	X	X	X	X	X	X	X	X	X	X											
55	206980	Fusible ( 3 A) Fusible Fusibile - Lichtsicherung - Fuse -	X	X	X	X	X	X	X	X	X	X											

+

Catalogue : 647000

6	ELECTRICITE (Poste de conduite) ELEKTRIZITÄT (Fahrerstand) ELECTRICIDAD (Puesto del conductor) ELECTRICITY (Cab structure) ELETRICO (Posto di pilotaggio)			Qté-Menge-Cant-Qty-Q.ta										11 CC		218		M					
	Rep Hinw Fig Item Rif	Numéro Teil-Nr Numero Part-Nr Part-Nr	Désignation Bezeichnung Descripcion Description Descrizione	1	2	3	4	5	6	7	8	9	10	11	12	13	14		15	16	17	18	19
				1- MH20-4T BUG. S2-E3	11-																		
				2- MH25-4T BUG. S2-E3	12-																		
				3- MSI 20T S2-E3	13-																		
				4- MSI 20T BUG. S2-E3	14-																		
				5- MSI 25T S2-E3	15-																		
				6- MSI 25T BUG. S2-E3	16-																		
				7- MSI 30T S2-E3	17-																		
				8- MSI 30T BUG. S2-E3	18-																		
				9- MSI 35T S2-E3	19-																		
				10- MSI 35T BUG. S2-E3	20-																		
56	473079	Fusible ( 20 A) Fusible Fusibile	- Lichtsicherung - Fuse -	X	X	X	X	X	X	X	X	X	X										
57	211012	Relais levage cabine Relé levantamiento cabina Centralina rele sollevamento cabina	- Relais Cab lifting - Cab lifting relay	1	1	1	1	1	1	1	1	1	1										
58	20125	Avertisseur Bocina Signalatore acustico	- Hüpe - Horn -	1	1	1	1	1	1	1	1	1	1										
59	57446	Vis H,M 8- 25-8.8-ZN8/C Tornillo Vite	- Schraube - Screw -	1	1	1	1	1	1	1	1	1	1										
60	42347	Vis H,M 8- 20-8.8-ZN8/C Tornillo Vite	- Schraube - Screw -	1	1	1	1	1	1	1	1	1	1										
61	61674	Rondelle M 8 ZN Arandela Rondella	- Unterlegscheibe - Washer -	2	2	2	2	2	2	2	2	2	2										
62	42325	Rondelle W 8 ZN Arandela Rondella	- Unterlegscheibe - Washer -	1	1	1	1	1	1	1	1	1	1										
63	58528	Ecrou H ,M 8 ZN Tuerca Dado	- Mutter - Nut -	2	2	2	2	2	2	2	2	2	2										
64	223594	Coupe-batterie Corte batería Interruttore batteria	- Unterbrecher - Breaker circuit -	1	1	1	1	1	1	1	1	1	1										
65	446726	Clé du coupe-batterie Llave de corte batería Chiave	- Schlüssel - Key -	1	1	1	1	1	1	1	1	1	1										
66	205275	Vis CBHc,M 6- 20-10.9-ZN5/NOIR- Tornillo Vite	- Schraube - Screw -	2	2	2	2	2	2	2	2	2	2										

+

**Catalogue : 647000**

7

ELECTRICITE (Poste de conduite)  
 ELEKTRIZITÄT (Fahrerstand)  
 ELECTRICIDAD (Puesto del conductor)  
 ELECTRICITY (Cab structure)  
 ELETRICO (Posto di pilotaggio)

Qté-Menge-Cant-Qty-Q.ta

11 CC

218

M

1-	MH20-4T	BUG. S2-E3	11-
2-	MH25-4T	BUG. S2-E3	12-
3-	MSI 20T	S2-E3	13-
4-	MSI 20T	BUG. S2-E3	14-
5-	MSI 25T	S2-E3	15-
6-	MSI 25T	BUG. S2-E3	16-
7-	MSI 30T	S2-E3	17-
8-	MSI 30T	BUG. S2-E3	18-
9-	MSI 35T	S2-E3	19-
10-	MSI 35T	BUG. S2-E3	20-

Rep Hinw Fig Item Rif	Numéro Teil-Nr Numero Part-Nr Part-Nr	Désignation Bezeichnung Descripcion Description Descrizione
67	29469	Rondelle M 6 ZN Arandela Rondella - Unterlegscheibe - Washer -

1	2	3	4	5	6	7	8	9	10	11	12	13	14	15	16	17	18	19	20
2	2	2	2	2	2	2	2	2	2										

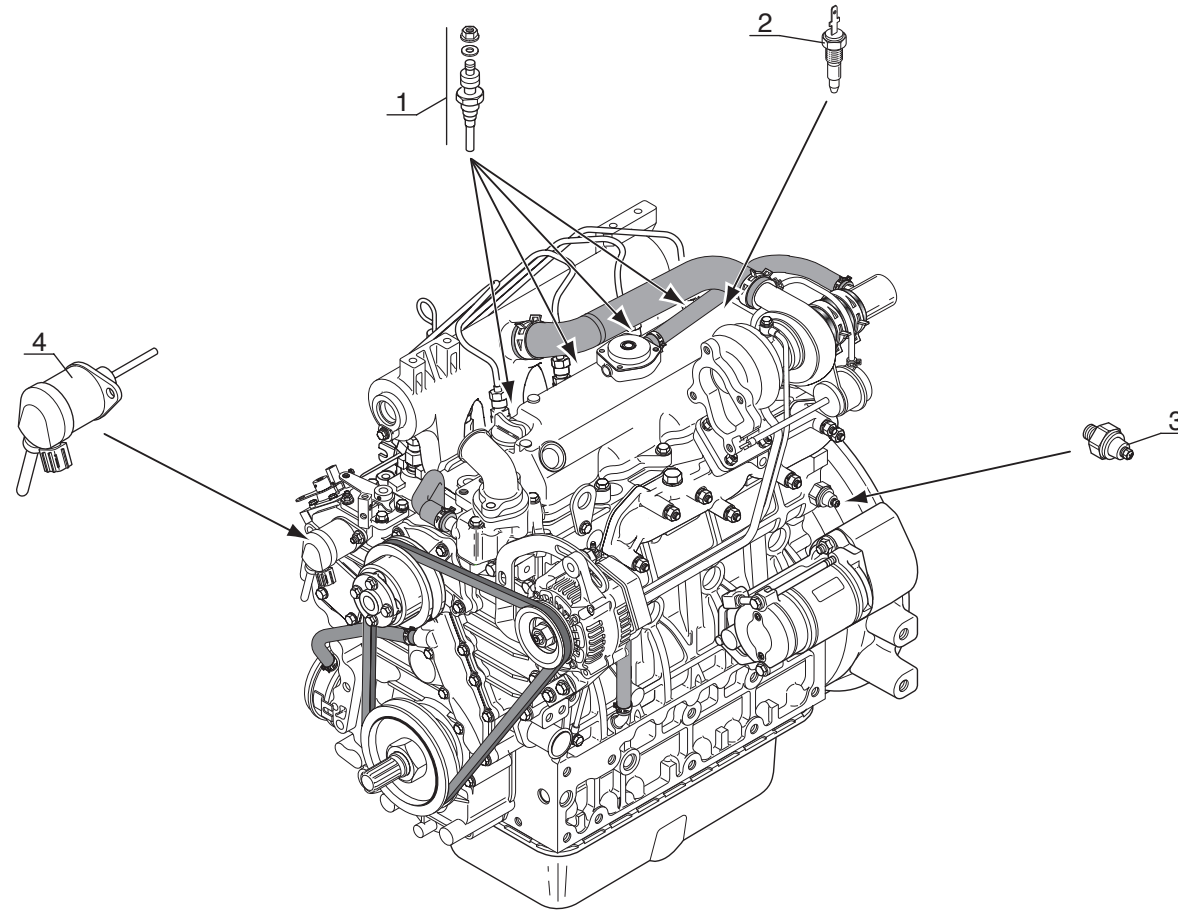



Catalogue : 647000

1

ELECTRICITE (Moteur - Transmission)  
 ELEKTRIZITÄT (Motor - Getriebe)  
 ELECTRICIDAD (Motor - Transmisión)  
 ELECTRICITY (Engine - Transmission)  
 ELETRICO (Motore - Transmissione)

Qté-Menge-Cant-Qty-Q.ta

11 CD

156

M

1-	MH20-4T	BUG.	S2-E3	11-
2-	MH25-4T	BUG.	S2-E3	12-
3-	MSI 20T	S2-E3		13-
4-	MSI 20T	BUG.	S2-E3	14-
5-	MSI 25T	S2-E3		15-
6-	MSI 25T	BUG.	S2-E3	16-
7-	MSI 30T	S2-E3		17-
8-	MSI 30T	BUG.	S2-E3	18-
9-	MSI 35T	S2-E3		19-
10-	MSI 35T	BUG.	S2-E3	20-

Rep Hinw Fig Item Rif	Numéro Teil-Nr Numero Part-Nr Part-Nr	Désignation Bezeichnung Descripcion Description Descrizione	1	2	3	4	5	6	7	8	9	10	11	12	13	14	15	16	17	18	19	20
1	823616	Bougie de préchauffage - Glühkerze Bujía de precalentamiento - Heating plug Termostarter -	4	4	4	4	4	4	4	4	4	4										
2	706324	Sonde de température d'eau - Wasser temperatur transmitte Sonda de temperatura de agua - Water temperature sensor Sonda di temperatura acqua -	1	1	1	1	1	1	1	1	1	1										
3	565345	Mano-contact pression huile moteur Ol motor druckschalter Mano contacto presión de aceite motor Engine oil pressure switch Interruttore pressione olio motore	1	1	1	1	1	1	1	1	1	1										
4	823584	Solénoïde - Solenoid Solenoid - Solenoid Solenoid -	1	1	1	1	1	1	1	1	1	1										

12 AA 524

ADHESIFS  
KLEBSTOFF  
ADHESIVO  
ADHESIVE  
ADESIVO

MH 20-4 T BUGGIE S2-E3  
MH 25-4 T BUGGIE S2-E3  
MSI 20 / 25 / 30 / 35 T S2-E3  
MSI 20 / 25 / 30 / 35 T BUGGIE S2-E3

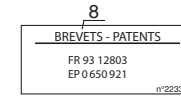
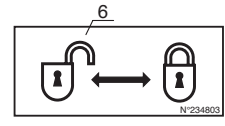
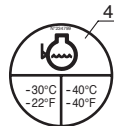
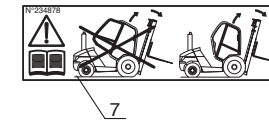
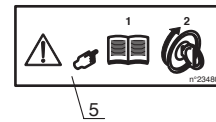
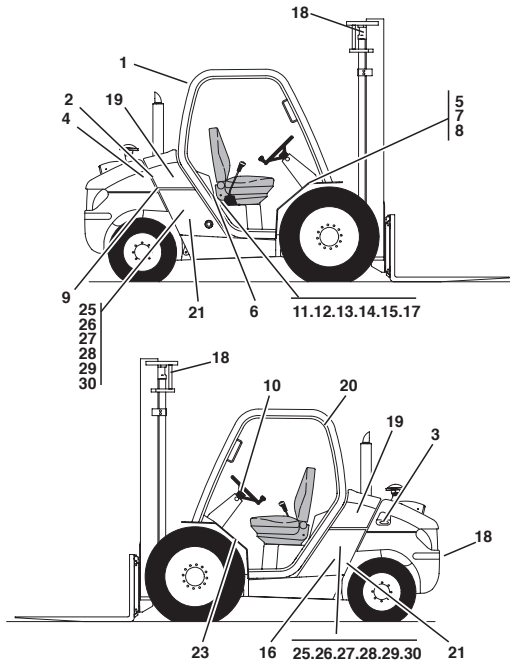

MANITOU	
<b>MOTEUR</b>	
VDANGE EFFECTUEE A	MANITOU
PROCHAINE VDANGE A	MANITOU
<b>AUTRES</b>	
BOITE	MANITOU
PONT	MANITOU
HYDRAULIQUE	MANITOU
GRAISSAGE	MANITOU
<b>FILTRES</b>	
HUILE	HYDRAULIQUE
AIR	CARBURANT

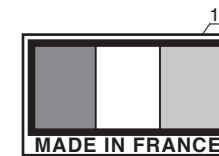
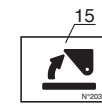
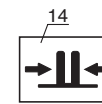
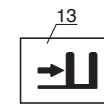
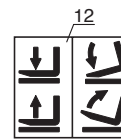
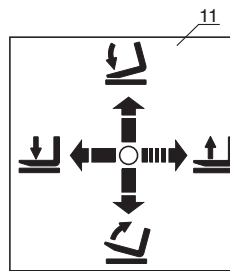

REPORQUAGE INTERDIT EN CAS DE PANNE, DANGER DE DETERIORATION DE LA TRANSMISSION HYDRAULIQUE  
CAUTION DO NOT MOVE THIS TRUCK BY PUSHING OR TOWING, EXTENSIVE TRANSMISSION DAMAGE WILL RESULT  
ABSCHLEPPEN VERBOTEN IM FALL EINER PANNE BESTEHT GEFAHR, DAS HYDRAULIK-GETRIEBE ZU ZERSTOERN  
REMOLQUE PROHIBIDO EN CASO DE AVERIA PELIGRO DE DETERIORACION DE LA TRANSMISION HIDRAULICA  
TRAINO INTERDETTO IN CASO DI GUASTO, PERICOLO DI DETERIORARE LA TRASMISSIONE IDRAULICA  
HINAUS KIELLETY KONEVAN SATTUESSA HYDRAULISEN VOIMANSIRRON VAURIOITUMISVAARA  
BOGSEERING FÖRBJUDEN VID MOTORSTOPP RISK FÖR SKADOR PÅ DET HYDRAULISKA TRANSMISSIONSSYSTEMET  
IN GEVAL VAN PANNE IS SLEPEN VERBODEN GEVAAR VOOR BESCHADIGING VAN DE HYDRAULISCHE TRANSMISSIE

**MSI 20 T** | 25

**MSI 25 T** | 26

**MSI 30 T** | 27

**MSI 35 T** | 28

**MH 20-4 T** | 29

**MH 25-4 T** | 30

**MANITOU** | 19

**BUGGIE** | 21

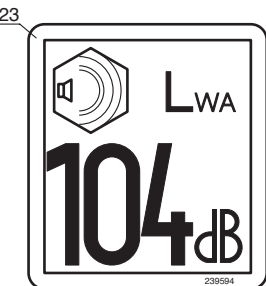

Catalogue : 647000

Qté-Menge-Cant-Qty-Q.ta

12 AA

524

M

Rep Hinw Fig Item Rif	Numéro Teil-Nr Numero Part-Nr Part-Nr	Désignation Bezeichnung Description Descrizione																				
			1	2	3	4	5	6	7	8	9	10	11	12	13	14	15	16	17	18	19	20
1	208230	Adhésif "Sigle conform. europ"- Klebstoff Adhesivo - Adhesive Adesivo -	1	1	1	1	1	1	1	1	1	1										
2	234798	Adhésif "Huile hydr.lev." - Klebstoff Adesivo - Adhesive Adesivo -	1	1	1	1	1	1	1	1	1	1										
3	234802	Adhésif "Diesel" - Klebstoff Adhesivo - Adhesive Adesivo -	1	1	1	1	1	1	1	1	1	1										
4	234799	Adhésif "Antigel" - Klebstoff Adhesivo - Adhesive Adesivo -	1	1	1	1	1	1	1	1	1	1										
5	234804	Adhésif "Inst. avant démarrage" Klebstoff Adhesivo - Adhesive Adesivo -	1	1	1	1	1	1	1	1	1	1										
6	234803	Adhésif "Verrou.déverrouillage" Klebstoff Adhesivo - Adhesive Adesivo -	1	1	1	1	1	1	1	1	1	1										
7	234878	Adhésif "Relevage cabine" - Klebstoff Adhesivo - Adhesive Adesivo -	1	1	1	1	1	1	1	1	1	1										
8	223323	Adhésif "Brevets" - Klebstoff Adhesivo - Adhesive Adesivo -	1	1	1	1	1	1	1	1	1	1										
9	719889	Adhésif "Entretien périodique"- Klebstoff Adhesivo - Adhesive Adesivo -	1	1	1	1	1	1	1	1	1	1										
10	76571	Adhésif "Inverseur" - Klebstoff Adhesivo - Adhesive Adesivo -	1	1	1	1	1	1	1	1	1	1										
11	203715	Adhésif "Fonct levier distr." - Klebstoff Adhesivo - Adhesive Adesivo -	1	1	1	1	1	1	1	1	1	1										

+

Catalogue : 647000

2

ADHESIF  
KLEBSTOFF  
ADHESIVO  
ADHESIVE  
ADESIVO

Qté-Menge-Cant-Qty-Q.ta

12 AA

524

M

1- MH20-4T BUG. S2-E3 11-  
2- MH25-4T BUG. S2-E3 12-  
3- MSI 20T S2-E3 13-  
4- MSI 20T BUG. S2-E3 14-  
5- MSI 25T S2-E3 15-  
6- MSI 25T BUG. S2-E3 16-  
7- MSI 30T S2-E3 17-  
8- MSI 30T BUG. S2-E3 18-  
9- MSI 35T S2-E3 19-  
10- MSI 35T BUG. S2-E3 20-

Rep Hinw Fig Item Rif	Numéro Teil-Nr Numero Part-Nr Part-Nr	Désignation Bezeichnung Description Descrizione	Qté-Menge-Cant-Qty-Q.ta																			
			1	2	3	4	5	6	7	8	9	10	11	12	13	14	15	16	17	18	19	20
12	200042	Adhésif "Fonct levier distr." - Klebstoff Adhesivo - Adhesive Adesivo -	1	1	1	1	1	1	1	1	1	1										
13	203791	Adhésif "Déplacement latéral" - Klebstoff Adhesivo - Adhesive Adesivo -	1	1	1	1	1	1	1	1	1	1										
14	203792	Adhésif "Ecartement fourches" - Klebstoff Adhesivo - Adhesive Adesivo -	1	1	1	1	1	1	1	1	1	1										
15	203929	Adhésif "Benne" - Klebstoff Adhesivo - Adhesive Adesivo -	1	1	1	1	1	1	1	1	1	1										
16	43345	Adhésif "Made in France" - Klebstoff Adhesivo - Adhesive Adesivo -	1	1	1	1	1	1	1	1	1	1										
17	203928	Adhésif "Rotation" - Klebstoff Adhesivo - Adhesive Adesivo -	1	1	1	1	1	1	1	1	1	1										
18	24653	Adhésif "Crochet point d'élingage" Klebstoff Adhesivo - Adhesive Adesivo -	3	3	3	3	3	3	3	3	3	3										
19	240807	Adhésif "MANITOU" Lg 300 (Blanc) Klebstoff (weiss) Adhesivo (blanco) - Adhesive (white) Adesivo (bianco) -	2	2	2	2	2	2	2	2	2	2										
20	172385	Adhésif "Remorque interdit" 5 langues Klebstoff Adhesivo - Adhesive Adesivo -	1	1	1	1	1	1	1	1	1	1										
21	204632	Adhésif "BUGGIE" - Klebstoff Adhesivo - Adhesive Adesivo -	2	2		2		2		2		2										

+

Catalogue : 647000

3

ADHESIF  
KLEBSTOFF  
ADHESIVO  
ADHESIVE  
ADESIVO

Qté-Menge-Cant-Qty-Q.ta

12 AA

524

M

- 1- MH20-4T BUG. S2-E3 11-
- 2- MH25-4T BUG. S2-E3 12-
- 3- MSI 20T S2-E3 13-
- 4- MSI 20T BUG. S2-E3 14-
- 5- MSI 25T S2-E3 15-
- 6- MSI 25T BUG. S2-E3 16-
- 7- MSI 30T S2-E3 17-
- 8- MSI 30T BUG. S2-E3 18-
- 9- MSI 35T S2-E3 19-
- 10- MSI 35T BUG. S2-E3 20-

Rep Hinw Fig Item Rif	Numéro Teil-Nr Numero Part-Nr Part-Nr	Désignation Bezeichnung Description Descrizione																				
			1	2	3	4	5	6	7	8	9	10	11	12	13	14	15	16	17	18	19	20
23	239594	Plaque "Puissance acoust 104dB" Platte Placa - Plate Piastra -	1	1	1	1	1	1	1	1	1	1										
25	255366	Adhésif "MSI 20T" Adhesivo - Klebstoff Adesivo - Adhesive -			2	2																
26	255367	Adhésif "MSI 25 T" Adhesivo - Klebstoff Adesivo - Adhesive -					2	2														
27	255368	Adhésif "MSI 30 T" Adhesivo - Klebstoff Adesivo - Adhesive -							2	2												
28	240836	Adhésif "MSI 35 T" Lg 370 Adhesivo - Klebstoff Adesivo - Adhesive -										2	2									
29	240837	Adhésif "MH 20-4T" Lg 360 Adhesivo - Klebstoff Adesivo - Adhesive -	2																			
30	240838	Adhésif "MH 25-4T" Lg 360 Adhesivo - Klebstoff Adesivo - Adhesive -		2																		



**MOTEUR - MOTOR**

**MOTOR - ENGINE**

**MOTORE**

**TYPE - TYPEN**

**TIPO - TYPE**

**TIPO**

**V2403-M-T-3EB-MNT-1**

**REFENCE - NUMMER**

**NUMERO - NUMBER**

**RIFERIMENTO**

**270 884**

**AK 144**

POUR MOTEUR  
FÜR MOTOR  
PARA MOTOR  
FOR ENGINE  
PER MOTORE

□ Type : V2403-M-T-3EB-MNT-1  
□ Ref : 270 884

ADAPTATION MOTEUR  
MOTOR ANPASSUNG  
ADAPTACION MOTOR  
ENGINE ADAPTATION  
ADATTAMENTO MOTORE

MH 20-4 T BUGGIE S2-E3  
MH 25-4 T BUGGIE S2-E3  
MSI 20 / 25 / 30 / 35 T S2-E3  
MSI 20 / 25 / 30 / 35 T BUGGIE S2-E3

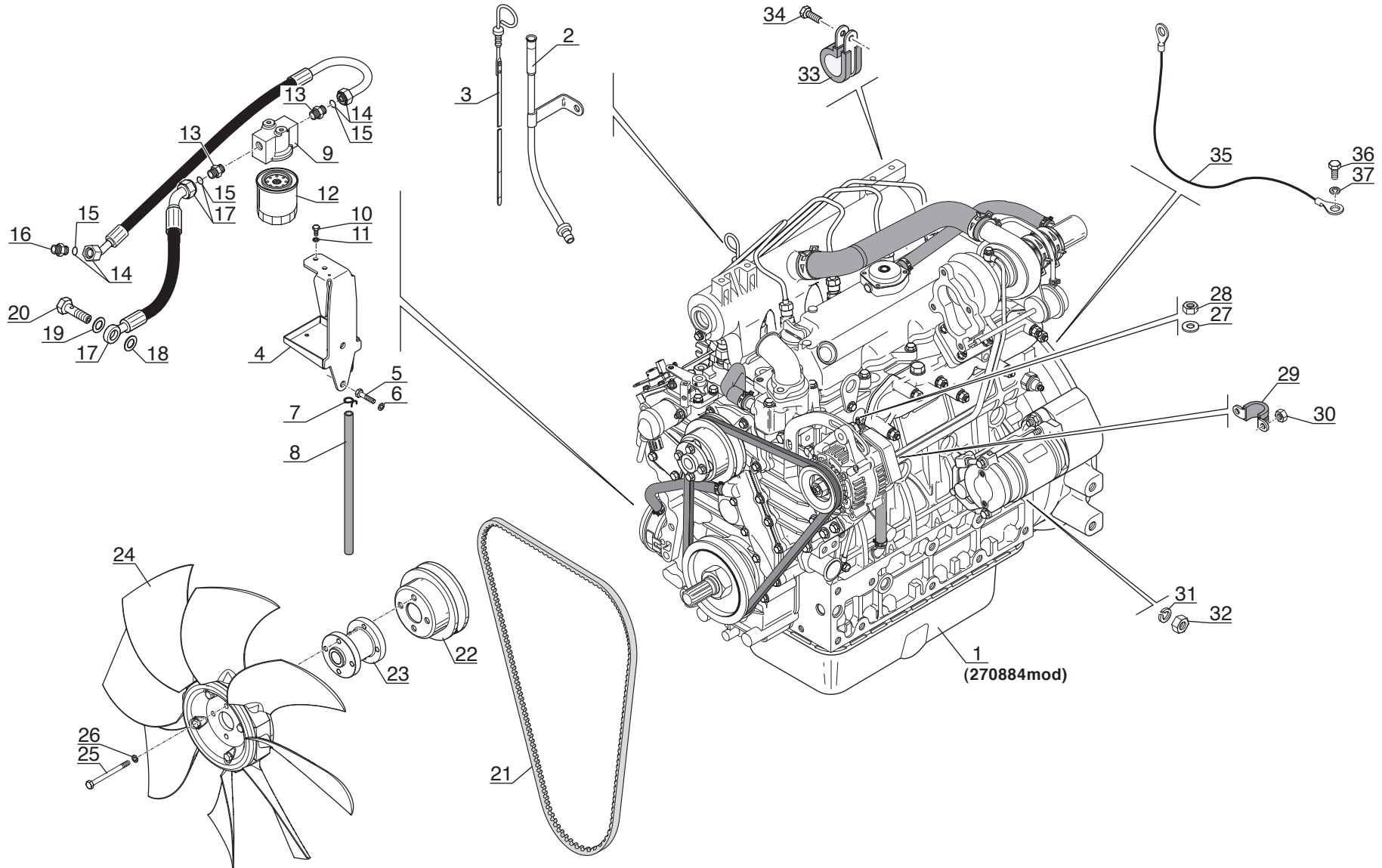



Catalogue : 647000

Qté-Menge-Cant-Qty-Q.ta

AK

144

M

1

ADAPTATION MOTEUR  
MOTOR ANPASSUNG  
ADAPTACION MOTOR  
ENGINE ADAPTATION  
ADATTAMENTO MOTORE

1- MH20-4T BUG. S2-E3 11-  
2- MH25-4T BUG. S2-E3 12-  
3- MSI 20T S2-E3 13-  
4- MSI 20T BUG. S2-E3 14-  
5- MSI 25T S2-E3 15-  
6- MSI 25T BUG. S2-E3 16-  
7- MSI 30T S2-E3 17-  
8- MSI 30T BUG. S2-E3 18-  
9- MSI 35T S2-E3 19-  
10- MSI 35T BUG. S2-E3 20-

Rep Hinw Fig Item Rif	Numéro Teil-Nr Numero Part-Nr Part-Nr	Désignation Bezeichnung Descripcion Description Descrizione	1 2 3 4 5 6 7 8 9 10 11 12 13 14 15 16 17 18 19 20																			
			1	2	3	4	5	6	7	8	9	10	11	12	13	14	15	16	17	18	19	20
1	270884	Moteur complet Motor completo Motore completo - Kompletter motor - Complete engine -	1	1	1	1	1	1	1	1	1	1	1									
2	823459	Tube Tubo Tubo - Rohr - Tube -	1	1	1	1	1	1	1	1	1	1	1									
3	823458	Jauge Galga Livello - Eichmass - Gauge -	1	1	1	1	1	1	1	1	1	1										
4	271018	Support filtre à huile Soporte filtro de aceite Supporto filtro olio - Ölfilter träger - Oil filter bracket -	1	1	1	1	1	1	1	1	1	1										
5	403358	Vis H,M12-125- 25-8.8-ZN8/C Tornillo Vite - Schraube - Screw -	2	2	2	2	2	2	2	2	2	2										
6	42231	Rondelle W12 ZN Arandela Rondella - Unterlegscheibe - Washer -	2	2	2	2	2	2	2	2	2	2										
7	211071	Collier Abrazadera Fascetta - Spannschelle - Clamp -	1	1	1	1	1	1	1	1	1	1										
8	274722	Durit Tubo flexible Manicotto - Schlauch - Hose -	1	1	1	1	1	1	1	1	1	1										
9	271378	Tête de filtre Cabeza de filtro Testa filtro - Filter kopf - Filter head -	1	1	1	1	1	1	1	1	1	1										
10	42347	Vis H,M 8- 20-8.8-ZN8/C Tornillo Vite - Schraube - Screw -	2	2	2	2	2	2	2	2	2	2										
11	42325	Rondelle W 8 ZN Arandela Rondella - Unterlegscheibe - Washer -	2	2	2	2	2	2	2	2	2	2										

+

Catalogue : 647000

2

ADAPTATION MOTEUR  
MOTOR ANPASSUNG  
ADAPTACION MOTOR  
ENGINE ADAPTATION  
ADATTAMENTO MOTORE

Qté-Menge-Cant-Qty-Q.ta

AK

144

M

1- MH20-4T BUG. S2-E3 11-  
2- MH25-4T BUG. S2-E3 12-  
3- MSI 20T S2-E3 13-  
4- MSI 20T BUG. S2-E3 14-  
5- MSI 25T S2-E3 15-  
6- MSI 25T BUG. S2-E3 16-  
7- MSI 30T S2-E3 17-  
8- MSI 30T BUG. S2-E3 18-  
9- MSI 35T S2-E3 19-  
10- MSI 35T BUG. S2-E3 20-

Rep Hinw Fig Item Rif	Numéro Teil-Nr Numero Part-Nr Part-Nr	Désignation Bezeichnung Descripcion Description Descrizione	Qté-Menge-Cant-Qty-Q.ta																			
			1	2	3	4	5	6	7	8	9	10	11	12	13	14	15	16	17	18	19	20
12	272192	Filtre à huile moteur Filtro aceite motor Filtro olio motore - Ol filter motor - Oil filter engine -	1	1	1	1	1	1	1	1	1	1										
13	268902	Raccord Union Racor Raccordo - Verschraubung - Connection -	2	2	2	2	2	2	2	2	2	2										
14	268873	Flexible Flexible Flessibile - Schlauch - Hose -	1	1	1	1	1	1	1	1	1	1										
15	189956	Joint torique Junta tórica Anello OR - "0" ring - "0" ring -	X	X	X	X	X	X	X	X	X	X										
16	268875	Raccord Union Racor Raccordo - Verschraubung - Connection -	1	1	1	1	1	1	1	1	1	1										
17	268874	Flexible Flexible Flessibile - Schlauch - Hose -	1	1	1	1	1	1	1	1	1	1										
18	268903	Joint cuivre Junta cobre Guarnizione rame - Kupferdichtung - Copper seal -	1	1	1	1	1	1	1	1	1	1										
19	5464	Joint cuivre Junta cobre Guarnizione rame - Kupferdichtung - Copper seal -	1	1	1	1	1	1	1	1	1	1										
20	273168	Vis creuse Tornillo hueco Vite cava - Hohlschraube - Hollow screw -	1	1	1	1	1	1	1	1	1	1										
21	747994	Courroie Correa Cinghia - Riemen - Belt -	1	1	1	1	1	1	1	1	1	1										
22	748022	Poulie de ventilateur Polea de ventilador Puleggia di ventola - Ventilatorriemenscheibe - Fan pulley -	1	1	1	1	1	1	1	1	1	1										

+

Catalogue : 647000

3

ADAPTATION MOTEUR  
MOTOR ANPASSUNG  
ADAPTACION MOTOR  
ENGINE ADAPTATION  
ADATTAMENTO MOTORE

Qté-Menge-Cant-Qty-Q.ta

AK

144

M

1- MH20-4T BUG. S2-E3 11-  
2- MH25-4T BUG. S2-E3 12-  
3- MSI 20T S2-E3 13-  
4- MSI 20T BUG. S2-E3 14-  
5- MSI 25T S2-E3 15-  
6- MSI 25T BUG. S2-E3 16-  
7- MSI 30T S2-E3 17-  
8- MSI 30T BUG. S2-E3 18-  
9- MSI 35T S2-E3 19-  
10- MSI 35T BUG. S2-E3 20-

Rep Hinw Fig Item Rif	Numéro Teil-Nr Numero Part-Nr Part-Nr	Désignation Bezeichnung Descripcion Description Descrizione	Qté-Menge-Cant-Qty-Q.ta																			
			1	2	3	4	5	6	7	8	9	10	11	12	13	14	15	16	17	18	19	20
23	270398	Entretoise Separador Distanziale - Querstrebe - Spacer -	1	1	1	1	1	1	1	1	1	1	1									
24	274196	Ventilateur soufflant Ventilador soplante Ventola - Ventilator Gebläse - Blower fan -	1	1	1	1	1	1	1	1	1	1										
25	165919	Vis H,M 6- 80-8.8-ZN5/C Tornillo Vite - Schraube - Screw -	4	4	4	4	4	4	4	4	4	4										
26	42316	Rondelle W 6 ZN Arandela Rondella - Unterlegscheibe - Washer -	4	4	4	4	4	4	4	4	4	4										
27	29469	Rondelle M 6 ZN Arandela Rondella - Unterlegscheibe - Washer -	1	1	1	1	1	1	1	1	1	1										
28	25714	Ecrou H ,M 6 ZN Tuerca Dado - Mutter - Nut -	1	1	1	1	1	1	1	1	1	1										
29	86505	Collier Abrazadera Fascetta - Spannschelle - Clamp -	1	1	1	1	1	1	1	1	1	1										
30	54232	Ecrou H ,M 5 ZN Tuerca Dado - Mutter - Nut -	2	2	2	2	2	2	2	2	2	2										
31	42325	Rondelle W 8 ZN Arandela Rondella - Unterlegscheibe - Washer -	1	1	1	1	1	1	1	1	1	1										
32	58528	Ecrou H ,M 8 ZN Tuerca Dado - Mutter - Nut -	1	1	1	1	1	1	1	1	1	1										
33	194492	Collier Abrazadera Fascetta - Spannschelle - Clamp -	1	1	1	1	1	1	1	1	1	1										

+

Catalogue : 647000

4

ADAPTATION MOTEUR  
 MOTOR ANPASSUNG  
 ADAPTACION MOTOR  
 ENGINE ADAPTATION  
 ADATTAMENTO MOTORE

Qté-Menge-Cant-Qty-Q.ta

AK

144

M

1-	MH20-4T	BUG. S2-E3	11-
2-	MH25-4T	BUG. S2-E3	12-
3-	MSI 20T	S2-E3	13-
4-	MSI 20T	BUG. S2-E3	14-
5-	MSI 25T	S2-E3	15-
6-	MSI 25T	BUG. S2-E3	16-
7-	MSI 30T	S2-E3	17-
8-	MSI 30T	BUG. S2-E3	18-
9-	MSI 35T	S2-E3	19-
10-	MSI 35T	BUG. S2-E3	20-

Rep Hinw Fig Item Rif	Numéro Teil-Nr Numero Part-Nr Part-Nr	Désignation Bezeichnung Descripcion Description Descrizione	Qté-Menge-Cant-Qty-Q.ta																			
			1	2	3	4	5	6	7	8	9	10	11	12	13	14	15	16	17	18	19	20
34	236381	Vis H,M 6- 14-8.8-ZN/5C Tornillo Vite	- Schraube - Screw -	1	1	1	1	1	1	1	1	1	1	1								
35	232470	Câble Cable Cavo	- Kabel - Cable -	1	1	1	1	1	1	1	1	1	1	1								
36	54951	Vis H,M 8- 16-8.8-ZN8/C Tornillo Vite	- Schraube - Screw -	1	1	1	1	1	1	1	1	1	1	1								
37	42325	Rondelle W 8 ZN Arandela Rondella	- Unterlegscheibe - Washer -	1	1	1	1	1	1	1	1	1	1	1								



# AK 150

POUR MOTEUR  
FÜR MOTOR  
PARA MOTOR  
FOR ENGINE  
PER MOTORE

□ Type : V2403-M-T-3EB-MNT-1  
□ Ref : 270 884

BLOC CYLINDRES  
ZYLINDERBLOCK  
BLOQUE DE CILINDROS  
CYLINDER BLOCK  
MONOBLOCCO CILINDRO

MH 20-4 T BUGGIE S2-E3  
MH 25-4 T BUGGIE S2-E3  
MSI 20 / 25 / 30 / 35 T S2-E3  
MSI 20 / 25 / 30 / 35 T BUGGIE S2-E3

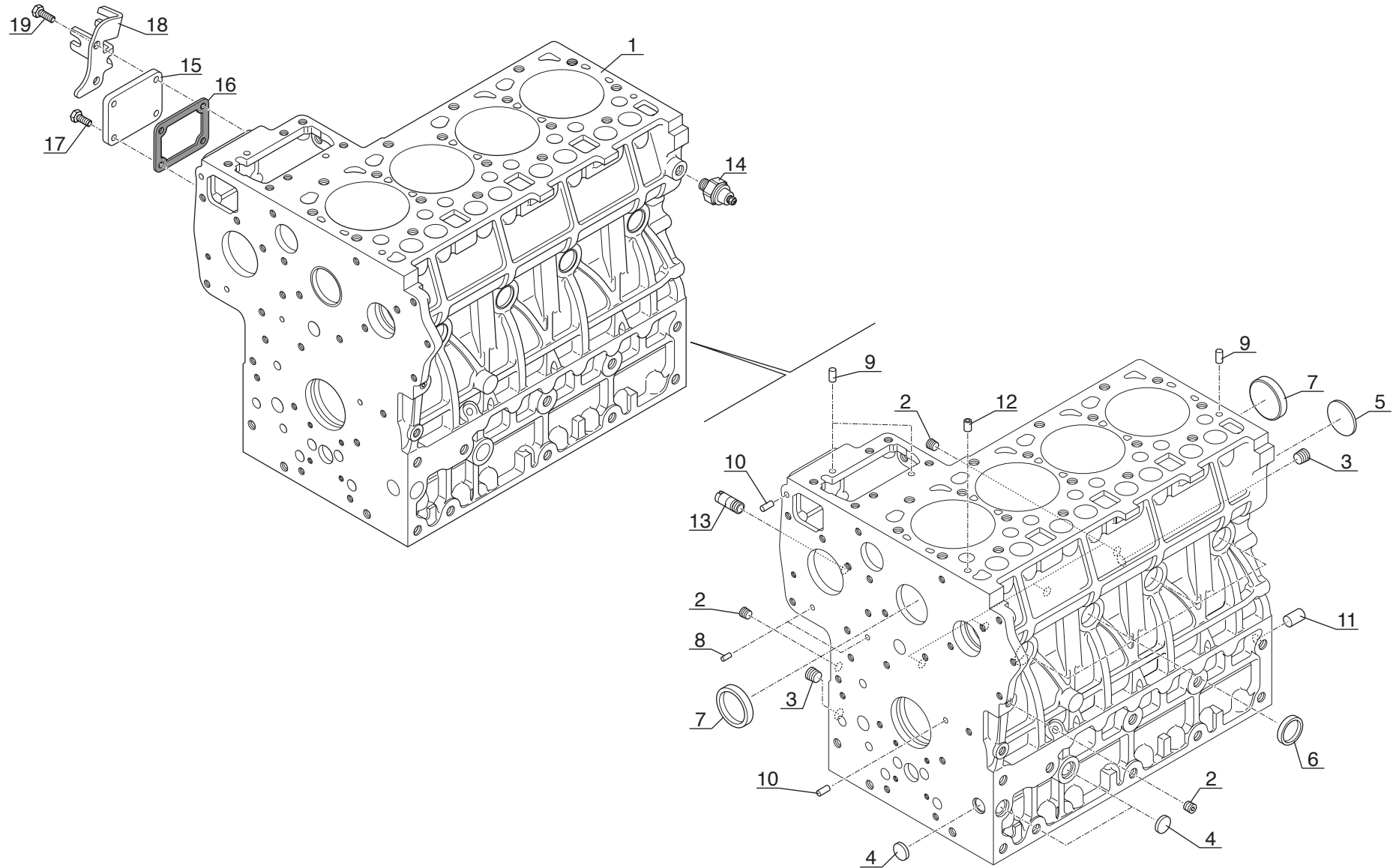

Catalogue : 270884MOD

Qté-Menge-Cant-Qty-Q.ta | AK 150 | M

1  
 BLOC CYLINDRES  
 ZYLINDERBLOCK  
 BLOQUE DE CILINDROS  
 CYLINDER BLOCK  
 MONOBLOCCO CILINDRO

1-	270884MOD	11-
2-		12-
3-		13-
4-		14-
5-		15-
6-		16-
7-		17-
8-		18-
9-		19-
10-		20-

Rep Hinw Fig Item Rif	Numéro Teil-Nr Numero Part-Nr Part-Nr	Désignation Bezeichnung Descripcion Description Descrizione
-----------------------------------	---	---

1	2	3	4	5	6	7	8	9	10	11	12	13	14	15	16	17	18	19	20
---	---	---	---	---	---	---	---	---	----	----	----	----	----	----	----	----	----	----	----

1	747936	Bloc cylindres complet Bloque de cilindros completo Blocco cilindri completo	- Kompletter zylinderblock - Complete cylinder block -
2	564980	Bouchon Tapón Tappo	- Stopfen - Plug -
3	565811	Bouchon Tapón Tappo	- Stopfen - Plug -
4	564981	Bouchon d'expansion Tapón Tappo	- Stopfen - Plug -
5	564982	Bouchon d'expansion Tapón Tappo	- Stopfen - Plug -
6	823405	Pastille Pastilla Pastiglia	- Spepsel abdichtu - Cap sealing -
7	823406	Pastille Pastilla Pastiglia	- Spepsel abdichtu - Cap sealing -
8	823407	Pion de centrage Espiga de centraje Perno di centraggio	- Zentrierstift - Centering pin -
9	823408	Pion de centrage Espiga de centraje Perno di centraggio	- Zentrierstift - Centering pin -
10	823409	Pion de centrage Espiga de centraje Perno di centraggio	- Zentrierstift - Centering pin -
11	823410	Pion de centrage Espiga de centraje Perno di centraggio	- Zentrierstift - Centering pin -

1																			
6																			
2																			
3																			
1																			
6																			
2																			
2																			
3																			
3																			
1																			

+

Catalogue : 270884MOD

2

BLOC CYLINDRES  
 ZYLINDERBLOCK  
 BLOQUE DE CILINDROS  
 CYLINDER BLOCK  
 MONOBLOCCO CILINDRO

Qté-Menge-Cant-Qty-Q.ta

AK

150

M

1-	270884MOD	11-
2-		12-
3-		13-
4-		14-
5-		15-
6-		16-
7-		17-
8-		18-
9-		19-
10-		20-

Rep Hinw Fig Item Rif	Numéro Teil-Nr Numero Part-Nr Part-Nr	Désignation Bezeichnung Descripcion Description Descrizione																				
			1	2	3	4	5	6	7	8	9	10	11	12	13	14	15	16	17	18	19	20
12	565813	Pion de centrage - Zentrierstift Espiga de centraje - Centering pin Perno di centraggio -	1																			
13	823411	Robinet - Hahn Grifo - Tap Rubinetto -	1																			
14	565345	Mano-contact pression huile moteur Ol motor druckschalter Mano contacto presión de aceite motor Engine oil pressure switch Interruttore pressione olio motore	1																			
15	823597	Plaque de fermeture - Schlussplatte Placa de cierre - Fastening plate Piastra di chiusura -	1																			
16	823598	Joint - Dichtung Junta - Seal Guarnizióne -	1																			
17	565024	Vis - Schraube Tornillo - Screw Vite -	2																			
18	823599	Support - Träger Soporte - Bracket Supporto -	1																			
19	565031	Vis - Schraube Tornillo - Screw Vite -	2																			





AK 151

POUR MOTEUR  
FÜR MOTOR  
PARA MOTOR  
FOR ENGINE  
PER MOTORE

□ Type : V2403-M-T-3EB-MNT-1  
□ Ref : 270 884

PISTONS - BIELLES - VILEBREQUIN  
KOLBEN - PLEUELSTANGE - KURBELWELLE  
PISTONES - BIELAS - CIGUENAL  
PISTONS - CONNECTING RODS - CRANK SHAFT  
PISTONI - BIELLE - ALBERO A MANOVELLA

MH 20-4 T BUGGIE S2-E3  
MH 25-4 T BUGGIE S2-E3  
MSI 20 / 25 / 30 / 35 T S2-E3  
MSI 20 / 25 / 30 / 35 T BUGGIE S2-E3

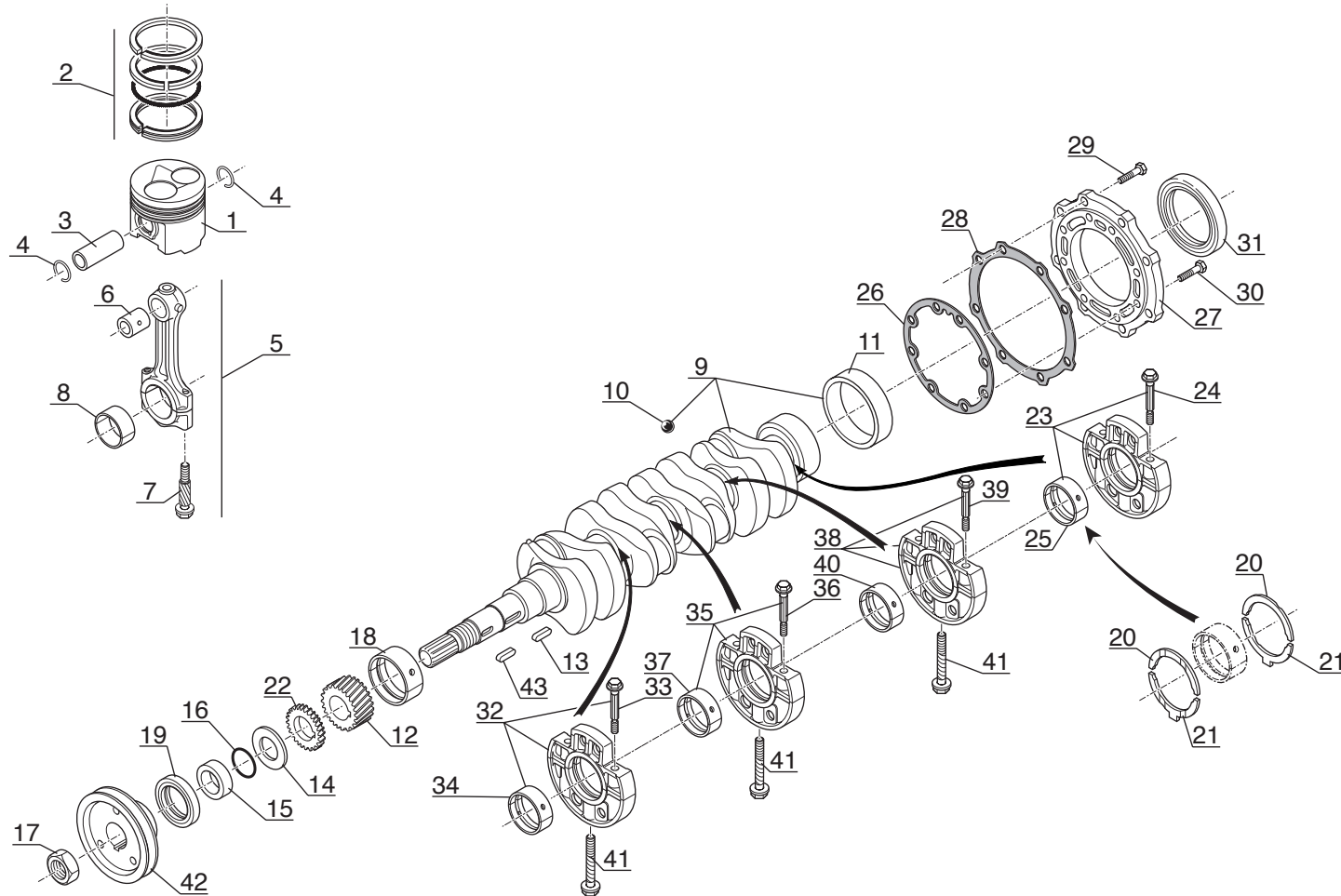

**Catalogue : 270884MOD**

Qté-Menge-Cant-Qty-Q.ta

AK

151

M

1

PISTONS, BIELLES ET VILEBREQUIN  
 KOLBEN, PLEUELSTANGE UND KURBELWELLE  
 PISTONES, BIELAS Y CYGUEÑAL  
 PISTONS, CONNECTING RODS AND CRANKSHAFT  
 PISTONI, BIELLE Y ALBERO A MANOVELLA

1- 270884MOD 11-  
 2- 12-  
 3- 13-  
 4- 14-  
 5- 15-  
 6- 16-  
 7- 17-  
 8- 18-  
 9- 19-  
 10- 20-

Rep Hinw Fig Item Rif	Numéro Teil-Nr Numero Part-Nr Part-Nr	Désignation Bezeichnung Descripcion Description Descrizione	Qté-Menge-Cant-Qty-Q.ta																			
			1	2	3	4	5	6	7	8	9	10	11	12	13	14	15	16	17	18	19	20
1	747961	Piston standard Pistón Pistone	- Kolben - Piston -	4																		
1	747962	Piston (+0,25 mm) Pistón Pistone	- Kolben - Piston -	X																		
2	747963	Jeu de segments standard Juego de segmentos Kit segmento	- Kolbenringsatz - Piston ring kit -	4																		
2	747964	Jeu de segments (+0,25 mm) Juego de segmentos Kit segmento	- Kolbenringsatz - Piston ring kit -	X																		
3	823514	Axe Eje Perno	- Bolzen - Pin -	4																		
4	823515	Circlips Aro retén Anello elastico	- Sicherungsring - Circlip -	8																		
5	747965	Bielle Biela Biella	- Pleuelstange - Connecting rod -	4																		
6	747966	Bague Anillo Anello	- Büchse - Bushing -	4																		
7	823518	Vis Tornillo Vite	- Schraube - Screw -	8																		
8	823519	Jeu de coussinets (Standard) Juego cojinetes (Estándard) Kit cuscinetto (Standard)	- Lagersatz (Standard) - Bearing kit (Standard) -	4																		
8	823520	Jeu de coussinets (-0,20 mm) Juego cojinetes Kit cuscinetto	- Lagersatz - Bearing kit -	X																		

+

**Catalogue : 270884MOD**

PISTONS, BIELLES ET VILEBREQUIN  
 KOLBEN, PLEUELSTANGE UND KURBELWELLE  
 PISTONES, BIELAS Y CYGUEÑAL  
 PISTONS, CONNECTING RODS AND CRANKSHAFT  
 PISTONI, BIELLE Y ALBERO A MANOVELLA

Qté-Menge-Cant-Qty-Q.ta

AK

151

M

2

Rep Hinw Fig Item Rif	Numéro Teil-Nr Numero Part-Nr Part-Nr	Désignation Bezeichnung Descripcion Description Descrizione	1 2 3 4 5 6 7 8 9 10 11 12 13 14 15 16 17 18 19 20																			
			1	2	3	4	5	6	7	8	9	10	11	12	13	14	15	16	17	18	19	20
8	823521	Jeu de coussinets (-0,40 mm) - Lagersatz Juego cojinetes - Bearing kit Kit cuscinetto -	X																			
9	747967	Vilebrequin - Kurbelwelle Cigueñal - Crankshaft Albero -	1																			
10	565048	Bille - Kugel Bola - Ball Sfera -	4																			
11	823523	Bague - Büchse Anillo - Bushing Anello -	1																			
12	747968	Pignon - Zahnrad Piñón - Gear Ingranaggio -	1																			
13	823525	Clavette - Keil Chaveta - Key Chiavetta -	1																			
14	823526	Rondelle - Unterlegscheibe Arandela - Washer Rondella -	1																			
15	823527	Bague - Büchse Anillo - Bushing Anello -	1																			
16	823528	Joint torique - "O" ring Junta tórica - "O" ring Anello OR -	1																			
17	823529	Ecrou - Mutter Tuerca - Nut Dado -	1																			
18	823530	Jeu de coussinets (Standard) - Lagersatz (Standard) Juego cojinetes (Estándar) - Bearing kit (Standard) Kit cuscinetto (Standard) -	1																			

+

Catalogue : 270884MOD

PISTONS, BIELLES ET VILEBREQUIN  
 KOLBEN, PLEUELSTANGE UND KURBELWELLE  
 PISTONES, BIELAS Y CYGUEÑAL  
 PISTONS, CONNECTING RODS AND CRANKSHAFT  
 PISTONI, BIELLE Y ALBERO A MANOVELLA

Qté-Menge-Cant-Qty-Q.ta

AK

151

M

3

1-	270884MOD	11-
2-		12-
3-		13-
4-		14-
5-		15-
6-		16-
7-		17-
8-		18-
9-		19-
10-		20-

Rep Hinw Fig Item Rif	Numéro Teil-Nr Numero Part-Nr Part-Nr	Désignation Bezeichnung Descripcion Description Descrizione	Qté-Menge-Cant-Qty-Q.ta																			
			1	2	3	4	5	6	7	8	9	10	11	12	13	14	15	16	17	18	19	20
18	823531	Jeu de coussinets (-0,20 mm) - Lagersatz Juego cojinetes - Bearing kit Kit cuscinetto -	X																			
18	823532	Jeu de coussinets (-0,40 mm) - Lagersatz Juego cojinetes - Bearing kit Kit cuscinetto -	X																			
19	823533	Joint - Dichtung Junta - Seal Guarnizióne -	1																			
20	823534	Rondelle de butée (Standard) Anschlagunterlegscheibe (Standard) Arandela de tope (Estándard) - Stop washer (Standard) Rondella reggisp (Standard) -	2																			
20	823535	Rondelle de butée (+0,20 mm) - Anschlagunterlegscheibe Arandela de tope - Stop washer Rondella reggisp -	X																			
20	823536	Rondelle de butée (+0,40 mm) - Anschlagunterlegscheibe Arandela de tope - Stop washer Rondella reggisp -	X																			
21	823537	Rondelle de butée (Standard) Anschlagunterlegscheibe (Standard) Arandela de tope (Estándard) - Stop washer (Standard) Rondella reggisp (Standard) -	2																			
21	823538	Rondelle de butée (+0,20 mm) - Anschlagunterlegscheibe Arandela de tope - Stop washer Rondella reggisp -	X																			
21	823539	Rondelle de butée (+0,40 mm) - Anschlagunterlegscheibe Arandela de tope - Stop washer Rondella reggisp -	X																			
22	747969	Pignon - Zahnrad Piñón - Gear Ingranaggio -	1																			
23	747954	Palier de vilebrequin - Kurbelwellenlager Cojinete de cigueñal - Main bearing case Cuscinetti dell'albero a gomito	1																			

+

**Catalogue : 270884MOD**

Qté-Menge-Cant-Qty-Q.ta

AK

151

M

4

PISTONS, BIELLES ET VILEBREQUIN  
 KOLBEN, PLEUELSTANGE UND KURBELWELLE  
 PISTONES, BIELAS Y CYGUEÑAL  
 PISTONS, CONNECTING RODS AND CRANKSHAFT  
 PISTONI, BIELLE Y ALBERO A MANOVELLA

1- 270884MOD 11-  
 2- 12-  
 3- 13-  
 4- 14-  
 5- 15-  
 6- 16-  
 7- 17-  
 8- 18-  
 9- 19-  
 10- 20-

Rep Hinw Fig Item Rif	Numéro Teil-Nr Numero Part-Nr Part-Nr	Désignation Bezeichnung Descripcion Description Descrizione	Qté-Menge-Cant-Qty-Q.ta																			
			1	2	3	4	5	6	7	8	9	10	11	12	13	14	15	16	17	18	19	20
24	823485	Vis Tornillo Vite - Schraube - Screw -	2																			
25	823486	Jeu de coussinets (Standard) Juego cojinetes (Estándar) Kit cuscinetto (Standard) - Lagersatz (Standard) - Bearing kit (Standard) -	1																			
25	823487	Jeu de coussinets (-0,20 mm) Juego cojinetes Kit cuscinetto - Lagersatz - Bearing kit -	X																			
25	823488	Jeu de coussinets (-0,40 mm) Juego cojinetes Kit cuscinetto - Lagersatz - Bearing kit -	X																			
26	823489	Joint Junta Guarnizióne - Dichtung - Seal -	1																			
27	747955	Carter Cárter Carter - Gehäuse - Housing -	1																			
28	823491	Joint Junta Guarnizióne - Dichtung - Seal -	1																			
29	600100	Vis Tornillo Vite - Schraube - Screw -	8																			
30	823492	Vis Tornillo Vite - Schraube - Screw -	8																			
31	823493	Joint Junta Guarnizióne - Dichtung - Seal -	1																			
32	747956	Palier de vilebrequin Cojinete de cigueñal Cuscinetti dell'albero a gomito - Kurbelwellenlager - Main bearing case -	1																			

+

**Catalogue : 270884MOD**

PISTONS, BIELLES ET VILEBREQUIN  
 KOLBEN, PLEUELSTANGE UND KURBELWELLE  
 PISTONES, BIELAS Y CYGUEÑAL  
 PISTONS, CONNECTING RODS AND CRANKSHAFT  
 PISTONI, BIELLE Y ALBERO A MANOVELLA

Qté-Menge-Cant-Qty-Q.ta

AK

151

M

5

1-	270884MOD	11-
2-		12-
3-		13-
4-		14-
5-		15-
6-		16-
7-		17-
8-		18-
9-		19-
10-		20-

Rep Hinw Fig Item Rif	Numéro Teil-Nr Numero Part-Nr Part-Nr	Désignation Bezeichnung Descripcion Description Descrizione	1	2	3	4	5	6	7	8	9	10	11	12	13	14	15	16	17	18	19	20
33	823485	Vis - Schraube Tornillo - Screw Vite -	2																			
34	823486	Jeu de coussinets (Standard) - Lagersatz (Standard) Juego cojinetes (Estándard) - Bearing kit (Standard) Kit cuscinetto (Standard) -	1																			
34	823487	Jeu de coussinets (-0,20 mm) - Lagersatz Juego cojinetes - Bearing kit Kit cuscinetto -	X																			
34	823488	Jeu de coussinets (-0,40 mm) - Lagersatz Juego cojinetes - Bearing kit Kit cuscinetto -	X																			
35	747957	Palier de vilebrequin - Kurbelwellenlager Cojinete de cigueñal - Main bearing case Cuscinetti dell'albero a gomito	1																			
36	823485	Vis - Schraube Tornillo - Screw Vite -	2																			
37	823486	Jeu de coussinets (Standard) - Lagersatz (Standard) Juego cojinetes (Estándard) - Bearing kit (Standard) Kit cuscinetto (Standard) -	1																			
37	823487	Jeu de coussinets (-0,20 mm) - Lagersatz Juego cojinetes - Bearing kit Kit cuscinetto -	X																			
37	823488	Jeu de coussinets (-0,40 mm) - Lagersatz Juego cojinetes - Bearing kit Kit cuscinetto -	X																			
38	747958	Palier de vilebrequin - Kurbelwellenlager Cojinete de cigueñal - Main bearing case Cuscinetti dell'albero a gomito	1																			
39	823485	Vis - Schraube Tornillo - Screw Vite -	2																			

+

**Catalogue : 270884MOD**

6

PISTONS, BIELLES ET VILEBREQUIN  
 KOLBEN, PLEUELSTANGE UND KURBELWELLE  
 PISTONES, BIELAS Y CYGUEÑAL  
 PISTONS, CONNECTING RODS AND CRANKSHAFT  
 PISTONI, BIELLE Y ALBERO A MANOVELLA

Qté-Menge-Cant-Qty-Q.ta

AK

151

M

1-	270884MOD	11-
2-		12-
3-		13-
4-		14-
5-		15-
6-		16-
7-		17-
8-		18-
9-		19-
10-		20-

Rep Hinw Fig Item Rif	Numéro Teil-Nr Numero Part-Nr Part-Nr	Désignation Bezeichnung Description Descrizione	1	2	3	4	5	6	7	8	9	10	11	12	13	14	15	16	17	18	19	20
40	823486	Jeu de coussinets (Standard) - Lagersatz (Standard) Juego cojinetes (Estándar) - Bearing kit (Standard) Kit cuscinetto (Standard) -	1																			
40	823487	Jeu de coussinets (-0,20 mm) - Lagersatz Juego cojinetes - Bearing kit Kit cuscinetto -	X																			
40	823488	Jeu de coussinets (-0,40 mm) - Lagersatz Juego cojinetes - Bearing kit Kit cuscinetto -	X																			
41	823497	Vis - Schraube Tornillo - Screw Vite -	3																			
42	747993	Poulie de vilebrequin - Kurbelwelle riemenscheibe Polea de cigueñal - Crankshaft pulley Puleggia di albero a gomito -	1																			
43	823502	Clavette - Keil Chaveta - Key Chiavetta -	1																			





AK 152

POUR MOTEUR  
FÜR MOTOR  
PARA MOTOR  
FOR ENGINE  
PER MOTORE

□ Type : V2403-M-T-3EB-MNT-1  
□ Ref : 270 884

CULASSE  
ZYLINDERKOPF  
CULATA  
CYLINDER HEAD  
TESTATA

MH 20-4 T BUGGIE S2-E3  
MH 25-4 T BUGGIE S2-E3  
MSI 20 / 25 / 30 / 35 T S2-E3  
MSI 20 / 25 / 30 / 35 T BUGGIE S2-E3

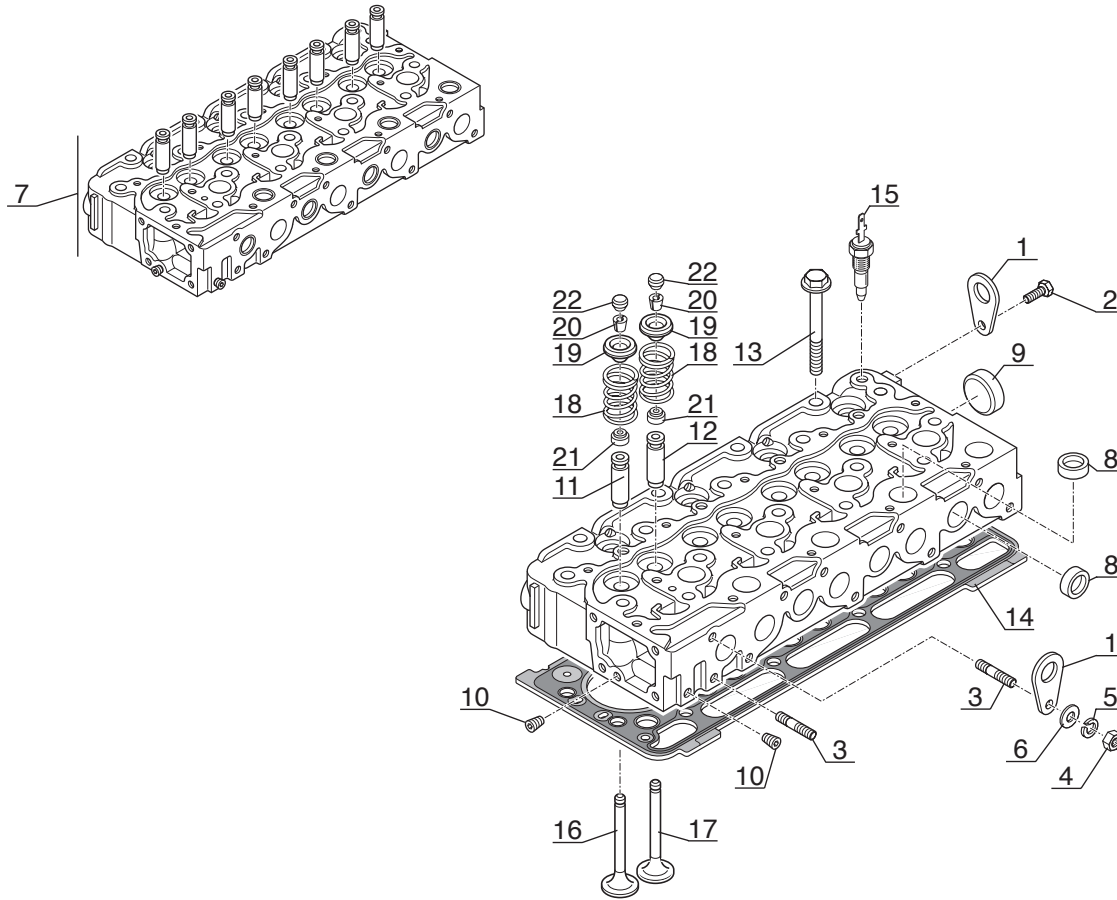



Catalogue : 270884MOD

Qté-Menge-Cant-Qty-Q.ta

AK

152

M

2

CULASSE  
ZYLINDERKOPF  
CULATA  
CYLINDER HEAD  
TESTATA

1-	270884MOD	11-
2-		12-
3-		13-
4-		14-
5-		15-
6-		16-
7-		17-
8-		18-
9-		19-
10-		20-

Rep Hinw Fig Item Rif	Numéro Teil-Nr Numero Part-Nr Part-Nr	Désignation Bezeichnung Descripcion Description Descrizione	1	2	3	4	5	6	7	8	9	10	11	12	13	14	15	16	17	18	19	20
12	823423	Guide (Soupape d'échappement) - Führungs (Auspuffventil ) Guía (Válvula de escape) - Guide (Escape) Guida (Valvola scarico) -	4																			
13	823424	Vis - Schraube Tornillo - Screw Vite -	18																			
14	747939	Joint de culasse (1,15 mm) - Zylinderkopfdichtung Junta de culata - Cylinder head gasket Guarnizióne testata -	1																			
14	747940	Joint de culasse (1,25 mm) - Zylinderkopfdichtung Junta de culata - Cylinder head gasket Guarnizióne testata -	X																			
14	747941	Joint de culasse (1,30 mm) - Zylinderkopfdichtung Junta de culata - Cylinder head gasket Guarnizióne testata -	X																			
14	747942	Joint de culasse (1,35 mm) - Zylinderkopfdichtung Junta de culata - Cylinder head gasket Guarnizióne testata -	X																			
14	823425	Joint de culasse (1,20 mm) - Zylinderkopfdichtung Junta de culata - Cylinder head gasket Guarnizióne testata -	X																			
15	706324	Sonde de température d'eau - Wasser temperatur transmitte Sonda de temperatura de agua - Water temperature sensor Sonda di temperatura acqua -	1																			
16	823694	Soupape admission - Einlassventil Valvula de admisión - Inlet valve Valvola aspirazione -	4																			
17	748023	Soupape d'échappement - Auspuffventil Válvula de escape Flusing and boost pressure valve Valvola scarico -	4																			
18	823696	Ressort - Feder Muelle - Spring Molla -	8																			

+



AK 153

POUR MOTEUR  
FÜR MOTOR  
PARA MOTOR  
FOR ENGINE  
PER MOTORE

□ Type : V2403-M-T-3EB-MNT-1  
□ Ref : 270 884

RAMPE DES CULBUTEURS  
KIPPEBELWELLE  
PERFIL DE BALANCIN  
ROCKER ARM SHAFT  
ASSE A BILANCIERI

MH 20-4 T BUGGIE S2-E3  
MH 25-4 T BUGGIE S2-E3  
MSI 20 / 25 / 30 / 35 T S2-E3  
MSI 20 / 25 / 30 / 35 T BUGGIE S2-E3

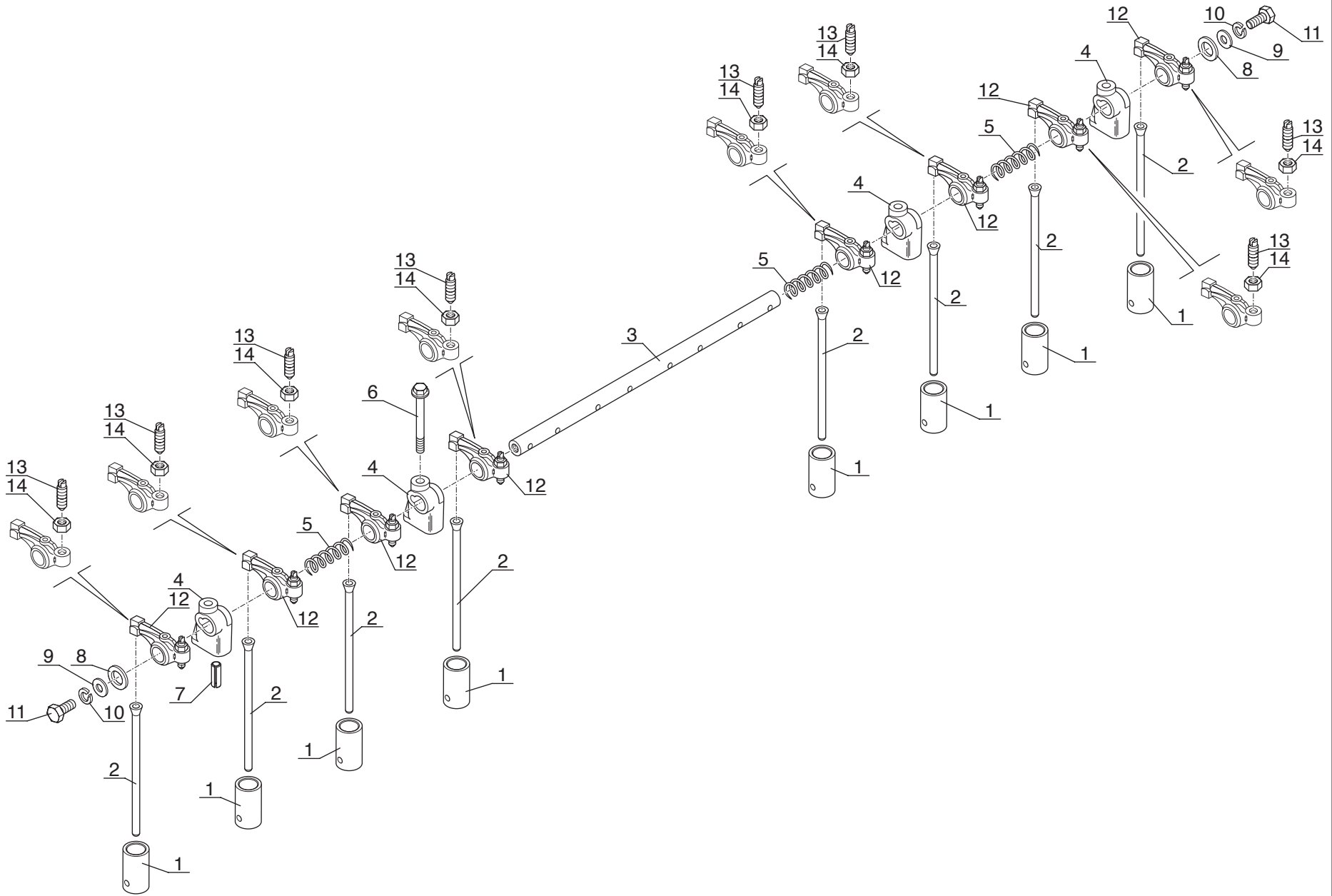

Catalogue : 270884MOD

Qté-Menge-Cant-Qty-Q.ta

AK

153

M

1

RAMPE DES CULBUTEURS  
KIPPHEBELWELLE  
PERFIL DE BALANCIN  
ROCKER LEVER SHAFT  
ASSE A BILANCIERI

1- 270884MOD 11-  
2- 12-  
3- 13-  
4- 14-  
5- 15-  
6- 16-  
7- 17-  
8- 18-  
9- 19-  
10- 20-

Rep Hinw Fig Item Rif	Numéro Teil-Nr Numero Part-Nr Part-Nr	Désignation Bezeichnung Descripcion Description Descrizione	1	2	3	4	5	6	7	8	9	10	11	12	13	14	15	16	17	18	19	20
1	823498	Poussoir Empujador Spintore - Stössel - Tappet -	8																			
2	823499	Tige de poussoir Vastago de empujador - Stosselstange - Push rod	8																			
3	823701	Arbre Arbol Albero - Welle - Shaft -	1																			
4	823702	Support Soporte Supporto - Träger - Bracket -	4																			
5	823703	Ressort Muelle Molla - Feder - Spring -	3																			
6	823704	Vis Tornillo Vite - Schraube - Screw -	4																			
7	823705	Goupille Pasador Spina - Stift - Pin -	1																			
8	823706	Rondelle Arandela Rondella - Unterlegscheibe - Washer -	2																			
9	565856	Rondelle Arandela Rondella - Unterlegscheibe - Washer -	2																			
10	600093	Rondelle Arandela Rondella - Unterlegscheibe - Washer -	2																			
11	823707	Vis Tornillo Vite - Schraube - Screw -	2																			

+







AK 154

POUR MOTEUR  
FÜR MOTOR  
PARA MOTOR  
FOR ENGINE  
PER MOTORE

□ Type : V2403-M-T-3EB-MNT-1  
□ Ref : 270 884

CARTER D' HUILE - POMPE A HUILE  
OLWANNE - SCHMIEROLPUMPE  
CARTER DE ACEITE - BOMBA DE ACEITE  
OIL SUMP - LUBRICATING OIL PUMP  
COPPA OLIO - POMPA LUBRIFICAZIONE

MH 20-4 T BUGGIE S2-E3  
MH 25-4 T BUGGIE S2-E3  
MSI 20 / 25 / 30 / 35 T S2-E3  
MSI 20 / 25 / 30 / 35 T BUGGIE S2-E3

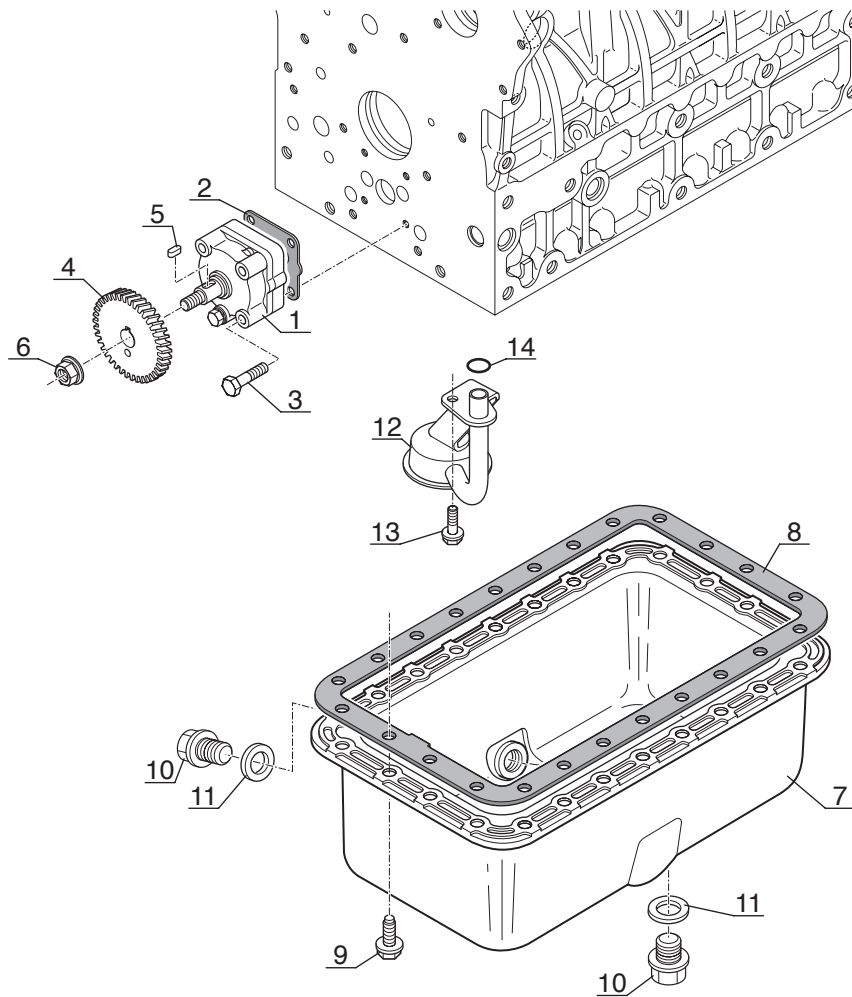

Catalogue : 270884MOD

Qté-Menge-Cant-Qty-Q.ta

AK

154

M

1

CARTER D'HUILE - POMPE A HUILE  
 OLWANNE - SCHMIEROLPUMPE  
 CARTER DE ACEITE - BOMBA DE ACEITE  
 OIL SUMP - LUBRICATING OIL PUMP  
 CARTER D'OLIO - POMPA LUBRIFICAZIONE

1- 270884MOD 11-  
 2- 12-  
 3- 13-  
 4- 14-  
 5- 15-  
 6- 16-  
 7- 17-  
 8- 18-  
 9- 19-  
 10- 20-

Rep Hinw Fig Item Rif	Numéro Teil-Nr Numero Part-Nr Part-Nr	Désignation Bezeichnung Descripcion Description Descrizione	Qté-Menge-Cant-Qty-Q.ta																			
			1	2	3	4	5	6	7	8	9	10	11	12	13	14	15	16	17	18	19	20
1	823460	Pompe à huile Bomba de aceite Pompa lubrificazione	- Schmierölpumpe - Lubricating oil pump -	1																		
2	823461	Joint Junta Guarnizióne	- Dichtung - Seal -	1																		
3	565144	Vis Tornillo Vite	- Schraube - Screw -	4																		
4	747953	Pignon Piñón Ingranaggio	- Zahnrad - Gear -	1																		
5	823463	Clavette Chaveta Chiavetta	- Keil - Key -	1																		
6	823464	Ecrou Tuerca Dado	- Mutter - Nut -	1																		
7	747937	Carter d'huile Carter de aceite Carter d'olio	- Olwanne - Oil sump -	1																		
8	823413	Joint Junta Guarnizióne	- Dichtung - Seal -	1																		
9	823414	Vis Tornillo Vite	- Schraube - Screw -	1																		
10	706247	Bouchon de vidange Tapón de vaciado Tappo di scarico	- Ablasschraube - Drain plug -	2																		
11	565001	Joint Junta Guarnizióne	- Dichtung - Seal -	2																		

+

2

## Catalogue : 270884MOD

CARTER D'HUILE - POMPE A HUILE  
 OLWANNE - SCHMIEROLPUMPE  
 CARTER DE ACEITE - BOMBA DE ACEITE  
 OIL SUMP - LUBRICATING OIL PUMP  
 CARTER D'OLIO - POMPA LUBRIFICAZIONE

Qté-Menge-Cant-Qty-Q.ta

AK

154

M

Rep Hinw Fig Item Rif	Numéro Teil-Nr Numero Part-Nr Part-Nr	Désignation Bezeichnung Descripcion Descrizione	Qté-Menge-Cant-Qty-Q.ta																			
			1	2	3	4	5	6	7	8	9	10	11	12	13	14	15	16	17	18	19	20
12	823415	Filtre Filtro Filtro	- Filter - Filter -	1																		
13	823416	Vis Tornillo Vite	- Schraube - Screw -	1																		
14	823417	Joint Junta Guarnizióne	- Dichtung - Seal -	1																		



AK 155

POUR MOTEUR  
FÜR MOTOR  
PARA MOTOR  
FOR ENGINE  
PER MOTORE

□ Type : V2403-M-T-3EB-MNT-1  
□ Ref : 270 884

CACHE CULBUTEUR ET RENIFLARD  
KIPPEBELDECKEL UND ENTLÜFTERROHR  
TAPA DE BALANCIN Y RESPIRADERO  
ROCKER LEVER COVER AND BREATHER  
PARA-BILANCIERE E SFIATATOIO

MH 20-4 T BUGGIE S2-E3  
MH 25-4 T BUGGIE S2-E3  
MSI 20 / 25 / 30 / 35 T S2-E3  
MSI 20 / 25 / 30 / 35 T BUGGIE S2-E3

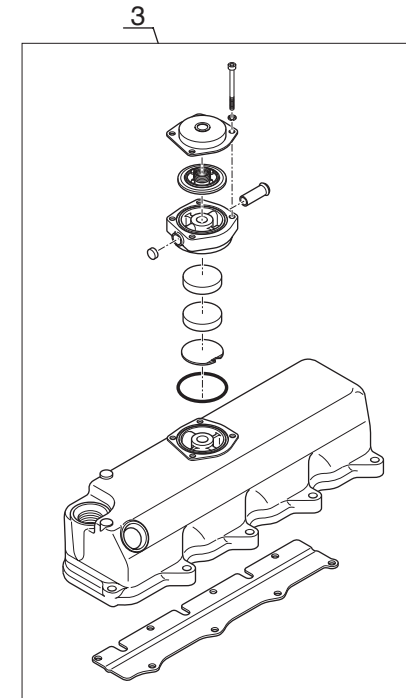
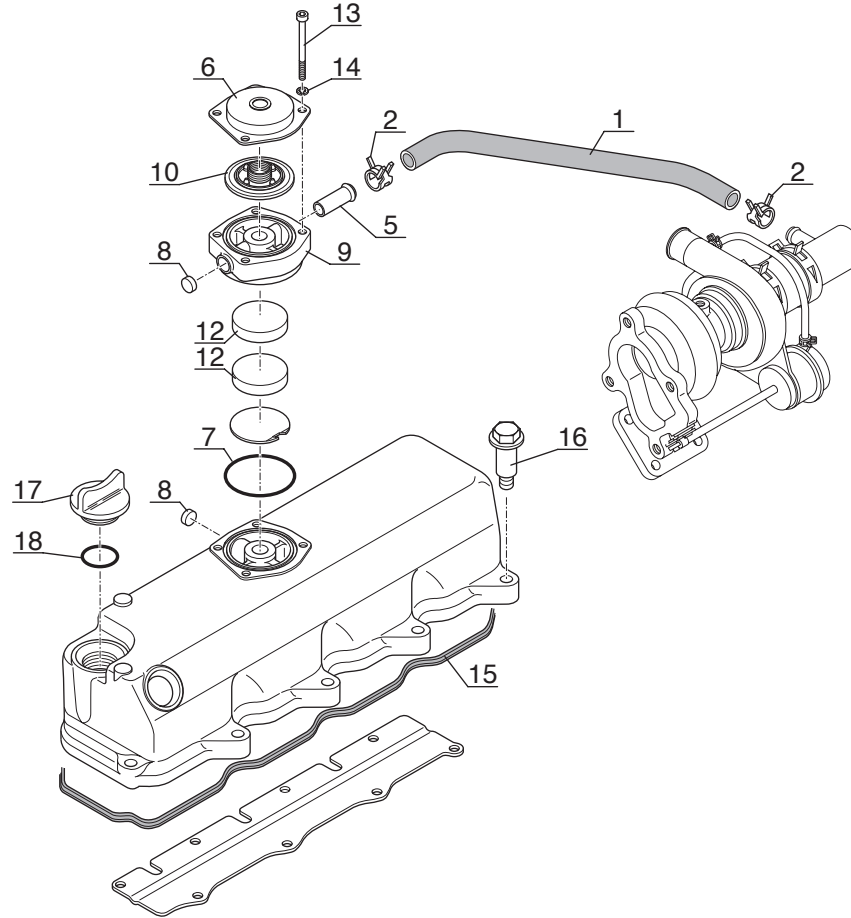

**Catalogue : 270884MOD**

**Qté-Menge-Cant-Qty-Q.ta**

**AK**

**155**

**M**

**1**

CACHE-CULBUTEUR ET RENIFLARD  
KIPPHEBELDECKEL UND ENTLÜFTERROHR  
TAPA DE BALANCIN Y RESPIRADERO  
ROCKER LEVER COVER AND BREATHER  
PARA-BILANCIERE E SFIATATOIO

1- 270884MOD 11-  
2- 12-  
3- 13-  
4- 14-  
5- 15-  
6- 16-  
7- 17-  
8- 18-  
9- 19-  
10- 20-

Rep Hinw Fig Item Rif	Numéro Teil-Nr Numero Part-Nr Part-Nr	Désignation Bezeichnung Descripcion Description Descrizione	Qté-Menge-Cant-Qty-Q.ta																			
			1	2	3	4	5	6	7	8	9	10	11	12	13	14	15	16	17	18	19	20
1	747946	Durit Tubo flexible Manicotto	- Schlauch - Hose -	1																		
2	706271	Collier Abrazadera Fascetta	- Spannschelle - Clamp -	2																		
3	747947	Cache-culbuteur complet Tapa de balancin completo Para-bilanciere completo	- Kompletter Kipphebeldeckel - Complete rocker lever cover -	1																		
5	706269	Raccord Racor Raccordo	- Verschraubung - Connection -	1																		
6	706267	Couvercle Tapadera Coperchio	- Deckel - Cover -	1																		
7	747948	Joint torique Junta tórica Anello OR	- "0" ring - "0" ring -	1																		
8	747949	Pastille Pastilla Pastiglia	- Spepsel abdichtu - Cap sealing -	2																		
9	747950	Entretoise Separador Distanziale	- Querstrebe - Spacer -	1																		
10	823451	Soupape Válvula Valvola	- Ventil - Valve -	1																		
12	565125	Filtre Filtro Filtro	- Filter - Filter -	2																		
13	747951	Vis Tornillo Vite	- Schraube - Screw -	4																		

+

2

## Catalogue : 270884MOD

CACHE-CULBUTEUR ET RENIFLARD  
 KIPPHEBELDECKEL UND ENTLÜFTERROHR  
 TAPA DE BALANCIN Y RESPIRADERO  
 ROCKER LEVER COVER AND BREATHER  
 PARA-BILANCIERE E SFIATATOIO

Qté-Menge-Cant-Qty-Q.ta

AK

155

M

1- 270884MOD 11-  
 2- 12-  
 3- 13-  
 4- 14-  
 5- 15-  
 6- 16-  
 7- 17-  
 8- 18-  
 9- 19-  
 10- 20-

Rep Hinw Fig Item Rif	Numéro Teil-Nr Numero Part-Nr Part-Nr	Désignation Bezeichnung Descripcion Description Descrizione																				
			1	2	3	4	5	6	7	8	9	10	11	12	13	14	15	16	17	18	19	20
14	565963	Rondelle Arandela Rondella	- Unterlegscheibe - Washer -	4																		
15	823452	Joint Junta Guarnizióne	- Dichtung - Seal -	1																		
16	706774	Vis Tornillo Vite	- Schraube - Screw -	10																		
17	565130	Bouchon de remplissage Tapón de llenado Tappo di riempimento	- Einfüllverschluss - Filling plug -	1																		
18	823455	Joint torique Junta tórica Anello OR	- "O" ring - "O" ring -	1																		





AK 156

POUR MOTEUR  
FÜR MOTOR  
PARA MOTOR  
FOR ENGINE  
PER MOTORE

□ Type : V2403-M-T-3EB-MNT-1  
□ Ref : 270 884

POMPE A EAU  
WASSER PUMPE  
BOMBA DE AGUA  
WATER PUMP  
POMPA DELL' ACQUA

MH 20-4 T BUGGIE S2-E3  
MH 25-4 T BUGGIE S2-E3  
MSI 20 / 25 / 30 / 35 T S2-E3  
MSI 20 / 25 / 30 / 35 T BUGGIE S2-E3

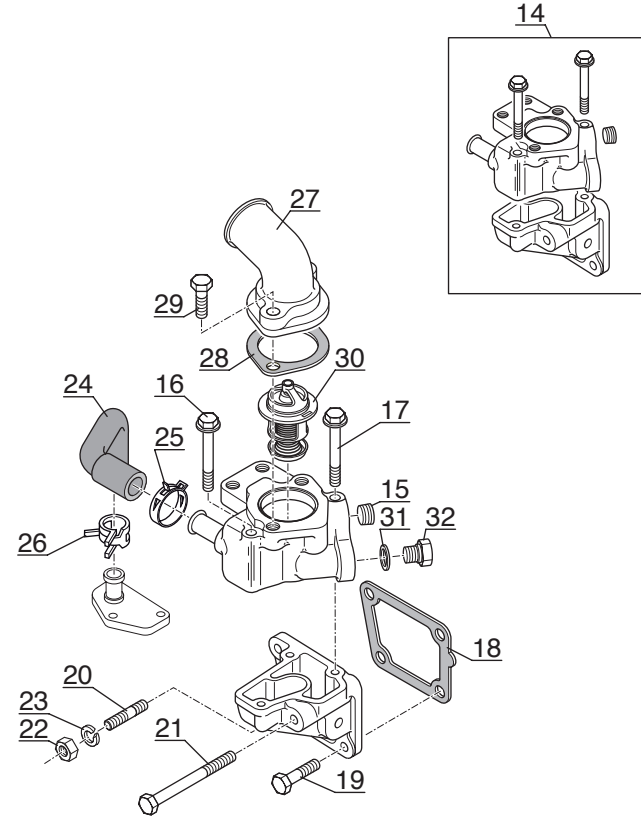
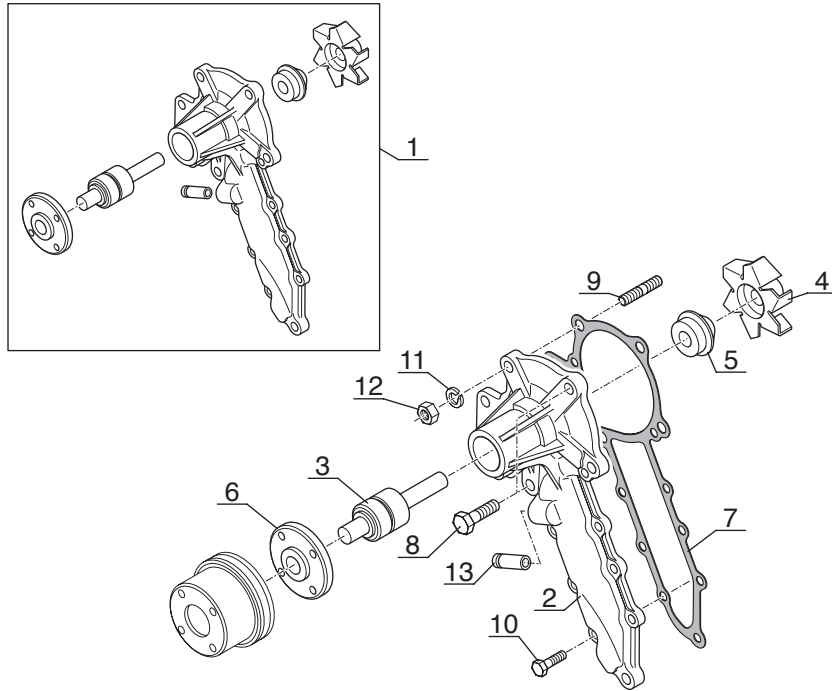

Catalogue : 270884MOD

Qté-Menge-Cant-Qty-Q.ta

AK

156

M

1

POMPE A EAU  
WASSER PUMPE  
BOMBA DE AGUA  
WATER PUMP  
POMPA DELL'ACQUA

1- 270884MOD 11-  
2- 12-  
3- 13-  
4- 14-  
5- 15-  
6- 16-  
7- 17-  
8- 18-  
9- 19-  
10- 20-

Rep Hinw Fig Item Rif	Numéro Teil-Nr Numero Part-Nr Part-Nr	Désignation Bezeichnung Descripcion Description Descrizione	1 2 3 4 5 6 7 8 9 10 11 12 13 14 15 16 17 18 19 20																			
			1	2	3	4	5	6	7	8	9	10	11	12	13	14	15	16	17	18	19	20
1	748018	Pompe à eau Bomba de agua Pompa acqua - Wasser pumpe - Water pump -	1																			
2	746939	Corps de pompe a eau Cuerpo de bomba Corpo di pompa - Pumpe körper - Pump body -	1																			
3	748019	Roulement Rodamiento Cuscinetto - Läger - Bearing -	1																			
4	823686	Rotor Rotor Rotore - Rotor - Rotor -	1																			
5	823687	Manchon Manguito Manicotto - Muffe - Coupling -	1																			
6	823688	Flasque Placa Flangia - Flansch - Flange -	1																			
7	746933	Joint Junta Guarnizióne - Dichtung - Seal -	1																			
8	823492	Vis Tornillo Vite - Schraube - Screw -	2																			
9	823690	Goujon Espárrago Prigioniero - Stiftschraube - Stud-bolt -	1																			
10	565157	Vis Tornillo Vite - Schraube - Screw -	6																			
11	600093	Rondelle Arandela Rondella - Unterlegscheibe - Washer -	1																			

+



Catalogue : 270884MOD

3

POMPE A EAU  
WASSER PUMPE  
BOMBA DE AGUA  
WATER PUMP  
POMPA DELL'ACQUA

Qté-Menge-Cant-Qty-Q.ta

AK

156

M

1-	270884MOD	11-
2-		12-
3-		13-
4-		14-
5-		15-
6-		16-
7-		17-
8-		18-
9-		19-
10-		20-

Rep Hinw Fig Item Rif	Numéro Teil-Nr Numero Part-Nr Part-Nr	Désignation Bezeichnung Descripcion Description Descrizione	Qté-Menge-Cant-Qty-Q.ta																			
			1	2	3	4	5	6	7	8	9	10	11	12	13	14	15	16	17	18	19	20
24	823675	Durit Tubo flexible Manicotto - Schlauch - Hose -	1																			
25	748016	Collier Abrazadera Fascetta - Spannschelle - Clamp -	1																			
26	823677	Collier Abrazadera Fascetta - Spannschelle - Clamp -	1																			
27	748017	Connexion Union Connessione - Verbindung - Connection -	1																			
28	706322	Joint Junta Guarnizióne - Dichtung - Seal -	1																			
29	565380	Vis Tornillo Vite - Schraube - Screw -	2																			
30	823679	Thermostat Termostato Termostato - Thermostat - Thermostat -	1																			
31	565003	Joint Junta Guarnizióne - Dichtung - Seal -	1																			
32	823448	Bouchon Tapón Tappo - Stopfen - Plug -	1																			

**AK 157**

POUR MOTEUR  
FÜR MOTOR  
PARA MOTOR  
FOR ENGINE  
PER MOTORE

□ Type : V2403-M-T-3EB-MNT-1  
□ Ref : 270 884

DISTRIBUTION ET ARBRE A CAMES  
STEUERGETRIEBE UND NOCKENWELLE  
DISTRIBUCION Y ARBOL DE LEVAS  
TIMING GEAR AND CAMSHAFT  
INGRANAGGI E ALBERO DELLA DISTRIBUZIONE

MH 20-4 T BUGGIE S2-E3  
MH 25-4 T BUGGIE S2-E3  
MSI 20 / 25 / 30 / 35 T S2-E3  
MSI 20 / 25 / 30 / 35 T BUGGIE S2-E3

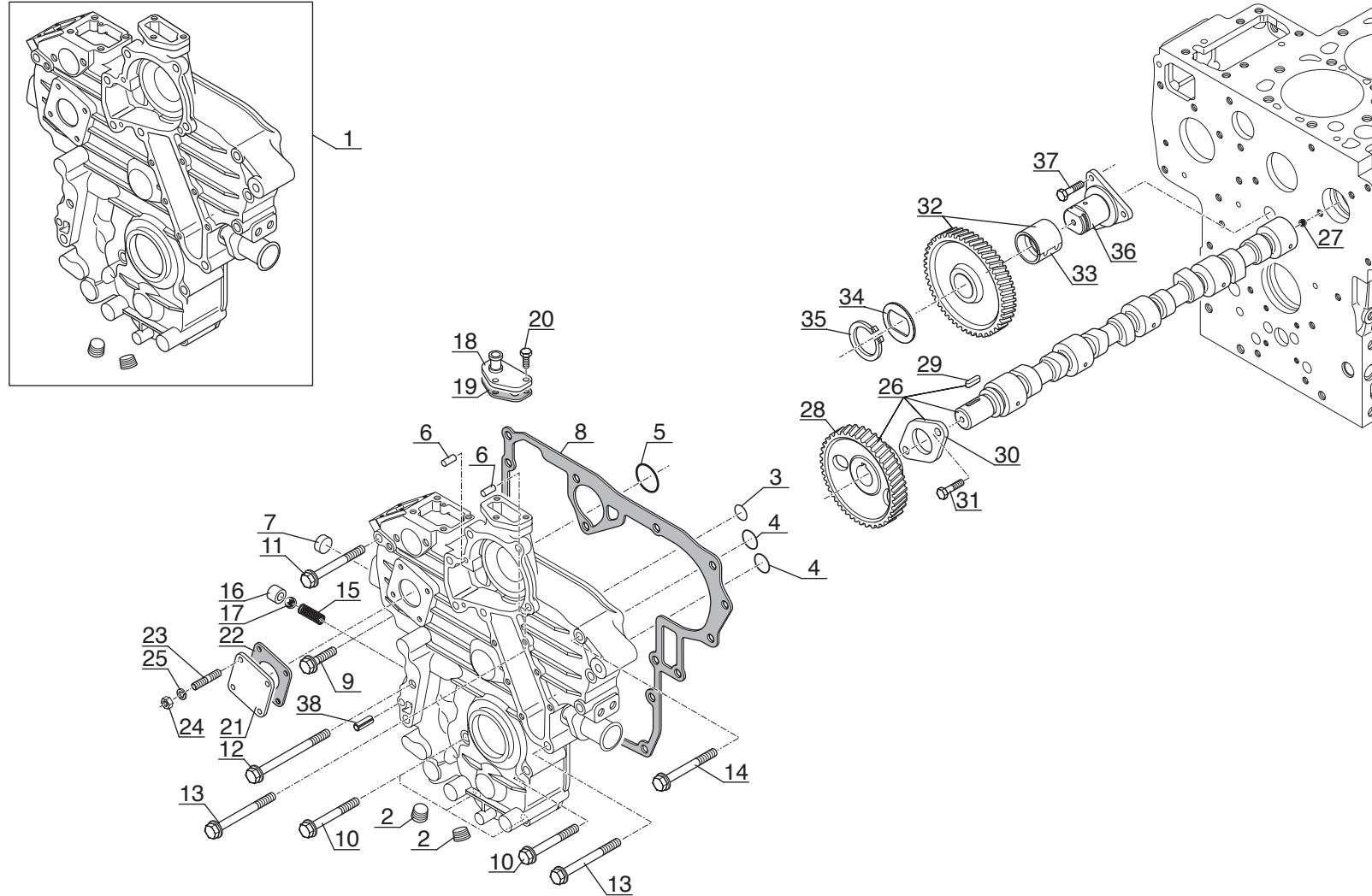

**Catalogue : 270884MOD**

DISTRIBUTION ET ARBRE A CAMES  
 STEUERGETRIEBE UND NOCKENWELLE  
 DISTRIBUCION Y ARBOL DE LEVAS  
 TIMING GEAR AND CAMSHAFT  
 INGRANAGGI E ALBERO DELLA DISTRIBUZIONE

Qté-Menge-Cant-Qty-Q.ta

AK

157

M

Rep Hinw Fig Item Rif	Numéro Teil-Nr Numero Part-Nr Part-Nr	Désignation Bezeichnung Descripcion Descrizione	1- 270884MOD 11- 2- 12- 3- 13- 4- 14- 5- 15- 6- 16- 7- 17- 8- 18- 9- 19- 10- 20-																			
			1	2	3	4	5	6	7	8	9	10	11	12	13	14	15	16	17	18	19	20
1	747943	Carter complet Cárter completo Carter completo	- Kompletter Gehäuse - Complete housing -	1																		
2	565119	Bouchon Tapón Tappo	- Stopfen - Plug -	2																		
3	823427	Joint torique Junta tórica Anello OR	- "0" ring - "0" ring -	1																		
4	823428	Joint torique Junta tórica Anello OR	- "0" ring - "0" ring -	2																		
5	823429	Joint torique Junta tórica Anello OR	- "0" ring - "0" ring -	1																		
6	823409	Pion de centrage Espiga de centrage Perno di centraggio	- Zentrierstift - Centering pin -	2																		
7	823444	Pastille Pastilla Pastiglia	- Spepsel abdichtu - Cap sealing -	1																		
8	746926	Joint Junta Guarnizióne	- Dichtung - Seal -	1																		
9	823431	Vis Tornillo Vite	- Schraube - Screw -	1																		
10	823432	Vis Tornillo Vite	- Schraube - Screw -	5																		
11	823433	Vis Tornillo Vite	- Schraube - Screw -	1																		

+

**Catalogue : 270884MOD**

DISTRIBUTION ET ARBRE A CAMES  
 STEUERGETRIEBE UND NOCKENWELLE  
 DISTRIBUCION Y ARBOL DE LEVAS  
 TIMING GEAR AND CAMSHAFT  
 INGRANAGGI E ALBERO DELLA DISTRIBUZIONE

Qté-Menge-Cant-Qty-Q.ta

AK

157

M

2

1-	270884MOD	11-
2-		12-
3-		13-
4-		14-
5-		15-
6-		16-
7-		17-
8-		18-
9-		19-
10-		20-

Rep Hinw Fig Item Rif	Numéro Teil-Nr Numero Part-Nr Part-Nr	Désignation Bezeichnung Descripcion Description Descrizione	Qté-Menge-Cant-Qty-Q.ta																			
			1	2	3	4	5	6	7	8	9	10	11	12	13	14	15	16	17	18	19	20
12	823434	Vis Tornillo Vite - Schraube - Screw -	2																			
13	823446	Vis Tornillo Vite - Schraube - Screw -	4																			
14	747944	Vis Tornillo Vite - Schraube - Screw -	1																			
15	823437	Ressort Muelle Molla - Feder - Spring -	1																			
16	823438	Siège de soupape Inserto Inserto - Verschlussdeckel - Insert -	1																			
17	823439	Bille Bola Sfera - Kugel - Ball -	1																			
18	823440	Platine Platina Piastra - Anschluss - Delivery port connection -	1																			
19	747945	Joint plat Junta plana Guarnizióne - Dichtung - Gasket -	1																			
20	565031	Vis Tornillo Vite - Schraube - Screw -	3																			
21	746893	Couvercle Tapadera Coperchio - Deckel - Cover -	1																			
22	746940	Joint Junta Guarnizióne - Dichtung - Seal -	1																			

+





**Catalogue : 270884MOD**

4

DISTRIBUTION ET ARBRE A CAMES  
 STEUERGETRIEBE UND NOCKENWELLE  
 DISTRIBUCION Y ARBOL DE LEVAS  
 TIMING GEAR AND CAMSHAFT  
 INGRANAGGI E ALBERO DELLA DISTRIBUZIONE

Qté-Menge-Cant-Qty-Q.ta

AK

157

M

1-	270884MOD	11-
2-		12-
3-		13-
4-		14-
5-		15-
6-		16-
7-		17-
8-		18-
9-		19-
10-		20-

Rep Hinw Fig Item Rif	Numéro Teil-Nr Numero Part-Nr Part-Nr	Désignation Bezeichnung Descripcion Description Descrizione
34	823507	Rondelle Arandela Rondella - Unterlegscheibe - Washer -
35	823508	Circlips Aro retén Anello elastico - Sicherungsring - Circlip -
36	823509	Arbre Arbol Albero - Welle - Shaft -
37	823504	Vis Tornillo Vite - Schraube - Screw -
38	823719	Goupille Pasador Spina - Stift - Pin -

1	2	3	4	5	6	7	8	9	10	11	12	13	14	15	16	17	18	19	20
1																			
1																			
1																			
3																			
1																			



**AK 158**

POUR MOTEUR  
FÜR MOTOR  
PARA MOTOR  
FOR ENGINE  
PER MOTORE

□ □ Type : V2403-M-T-3EB-MNT-1  
□ □ Ref : 270 884

REFROIDISSEUR D' HUILE  
ÖLKUHLER  
ENFRIADOR DE ACEITE  
OIL COOLER  
REFRIGERATORE INTEGRALE

MH 20-4 T BUGGIE S2-E3  
MH 25-4 T BUGGIE S2-E3  
MSI 20 / 25 / 30 / 35 T S2-E3  
MSI 20 / 25 / 30 / 35 T BUGGIE S2-E3

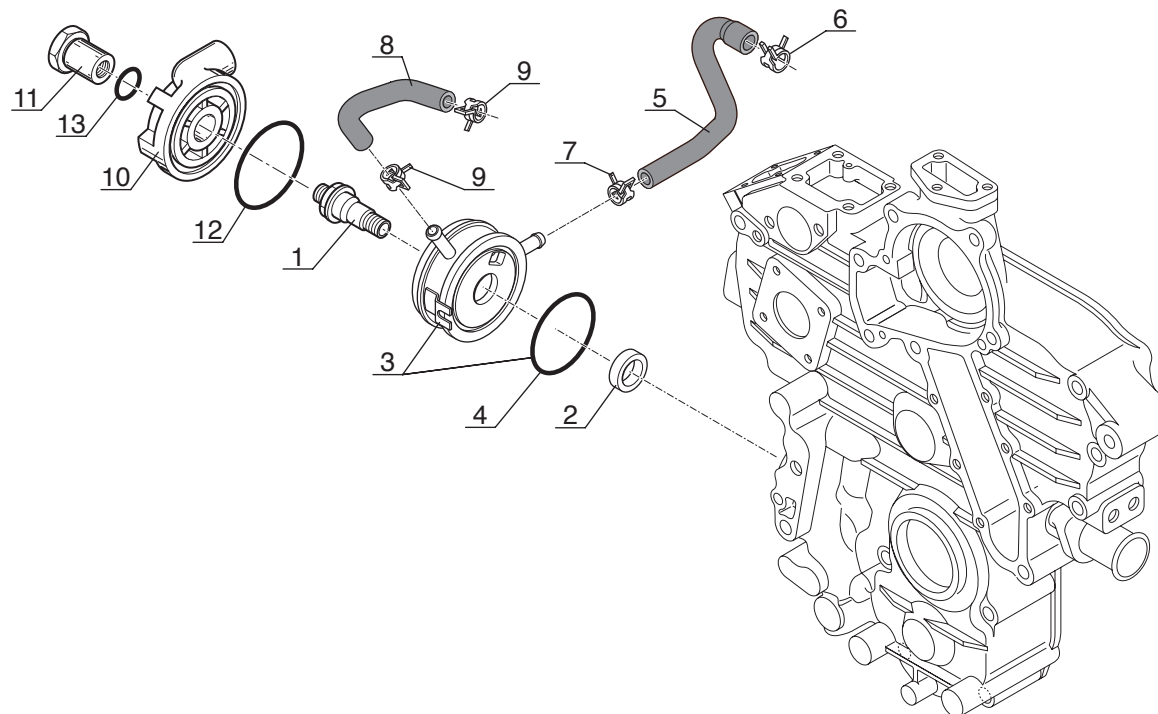

Catalogue : 270884MOD

Qté-Menge-Cant-Qty-Q.ta

AK

158

M

1

REFROIDISSEUR D'HUILE  
ÖLKÜHLER  
ENFRIADOR DE ACEITE  
OIL COOLER  
REFRIGERATORE INTEGRALE

1- 270884MOD 11-  
2- 12-  
3- 13-  
4- 14-  
5- 15-  
6- 16-  
7- 17-  
8- 18-  
9- 19-  
10- 20-

Rep Hinw Fig Item Rif	Numéro Teil-Nr Numero Part-Nr Part-Nr	Désignation Bezeichnung Descripcion Description Descrizione	Qté-Menge-Cant-Qty-Q.ta																			
			1	2	3	4	5	6	7	8	9	10	11	12	13	14	15	16	17	18	19	20
1	747952	Raccord Racor Raccordo	- Verschraubung - Connection -	1																		
2	823457	Bague Anillo Anello	- Büchse - Bushing -	1																		
3	748050	Refroidisseur d'huile Enfriador de aceite Refrigeratore integrale	- Ölkühler - Oil cooler -	1																		
4	823718	Joint torique Junta tórica Anello OR	- "0" ring - "0" ring -	1																		
5	823720	Durit Tubo flexible Manicotto	- Schlauch - Hose -	1																		
6	823677	Collier Abrazadera Fascetta	- Spannschelle - Clamp -	1																		
7	565182	Collier Abrazadera Fascetta	- Spannschelle - Clamp -	1																		
8	823721	Durit Tubo flexible Manicotto	- Schlauch - Hose -	1																		
9	565182	Collier Abrazadera Fascetta	- Spannschelle - Clamp -	2																		
10	748051	Adaptateur Adaptador Adattatore	- Verbindung - Adaptor -	1																		
11	748052	Raccord Racor Raccordo	- Verschraubung - Connection -	1																		

+

**Catalogue : 270884MOD**

2

REFROIDISSEUR D'HUILE  
 ÖLKÜHLER  
 ENFRIADOR DE ACEITE  
 OIL COOLER  
 REFRIGERATORE INTEGRALE

Qté-Menge-Cant-Qty-Q.ta

AK

158

M

1-	270884MOD	11-
2-		12-
3-		13-
4-		14-
5-		15-
6-		16-
7-		17-
8-		18-
9-		19-
10-		20-

Rep Hinw Fig Item Rif	Numéro Teil-Nr Numero Part-Nr Part-Nr	Désignation Bezeichnung Descripcion Descrizione
12	748053	Joint torique - "0" ring Junta tórica - "0" ring Anello OR -
13	748054	Joint torique - "0" ring Junta tórica - "0" ring Anello OR -

1	2	3	4	5	6	7	8	9	10	11	12	13	14	15	16	17	18	19	20
1																			
1																			



**AK 159**

POUR MOTEUR  
FÜR MOTOR  
PARA MOTOR  
FOR ENGINE  
PER MOTORE

□ Type : V2403-M-T-3EB-MNT-1  
□ Ref : 270 884

VOLANT-MOTEUR - DEMARREUR  
SCHWUNGRAD - ANLASSER  
VOLANTE-MOTOR - MOTOR DE ARANQUE  
FLYWHEEL - STARTER MOTOR  
VOLANO MOTORE - MOTORINO AVVIAMENTO

MH 20-4 T BUGGIE S2-E3  
MH 25-4 T BUGGIE S2-E3  
MSI 20 / 25 / 30 / 35 T S2-E3  
MSI 20 / 25 / 30 / 35 T BUGGIE S2-E3

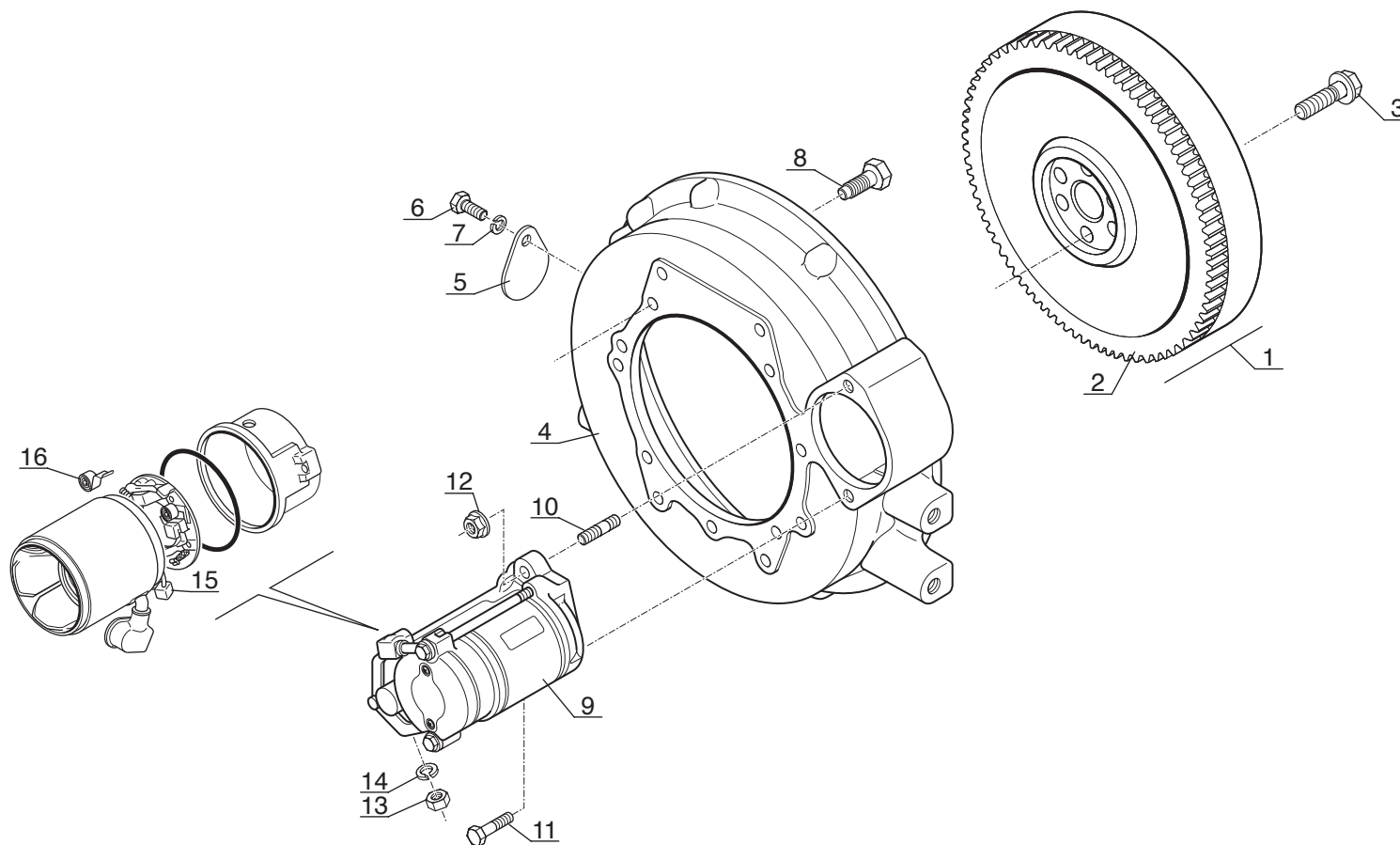



**Catalogue : 270884MOD**

Qté-Menge-Cant-Qty-Q.ta

AK

159

M

1

VOLANT MOTEUR - DEMARREUR  
 SCHWUNGRAD - ANLASSER  
 VOLANTE MOTOR - MOTOR DE ARANQUE  
 FLY WHEEL - STARTER MOTOR  
 VOLANO MOTORE - MOTORINO AVVIAMENTO

1-	270884MOD	11-
2-		12-
3-		13-
4-		14-
5-		15-
6-		16-
7-		17-
8-		18-
9-		19-
10-		20-

Rep Hinw Fig Item Rif	Numéro Teil-Nr Numero Part-Nr Part-Nr	Désignation Bezeichnung Description Descrizione																				
			1	2	3	4	5	6	7	8	9	10	11	12	13	14	15	16	17	18	19	20
1	747970	Volant moteur complet Volante motor completo Volano motore completo	- Kompletter Schwungrad - Complete fly wheel -	1																		
2	823541	Couronne Corona Corona	- Zahnrad - Gear -	1																		
3	746894	Vis Tornillo Vite	- Schraube - Screw -	6																		
4	747971	Carter volant moteur Cárter volante motor Carcassa volano motorino	- Schwungradgehäuse - Flywheel housing -	1																		
5	823547	Plaque de fermeture Placa de cierre Piastra di chiusura	- Schlussplatte - Fastening plate -	1																		
6	823707	Vis Tornillo Vite	- Schraube - Screw -	1																		
7	600093	Rondelle Arandela Rondella	- Unterlegscheibe - Washer -	1																		
8	823549	Vis Tornillo Vite	- Schraube - Screw -	11																		
9	748014	Démarrreur Arrancador Motorino avviamento	- Anlasser - Starter motor -	1																		
10	823651	Goujon Espárrago Prigioniero	- Stiftschraube - Stud-bolt -	1																		
11	565268	Vis Tornillo Vite	- Schraube - Screw -	1																		

+





**AK 160**

POUR MOTEUR  
FÜR MOTOR  
PARA MOTOR  
FOR ENGINE  
PER MOTORE

□ □ Type : V2403-M-T-3EB-MNT-1  
□ □ Ref : 270 884

ALTERNATEUR  
WECHSELSTROMGENERATOR  
ALTERNADOR  
ALTERNATOR  
ALTERNATORE

MH 20-4 T BUGGIE S2-E3  
MH 25-4 T BUGGIE S2-E3  
MSI 20 / 25 / 30 / 35 T S2-E3  
MSI 20 / 25 / 30 / 35 T BUGGIE S2-E3

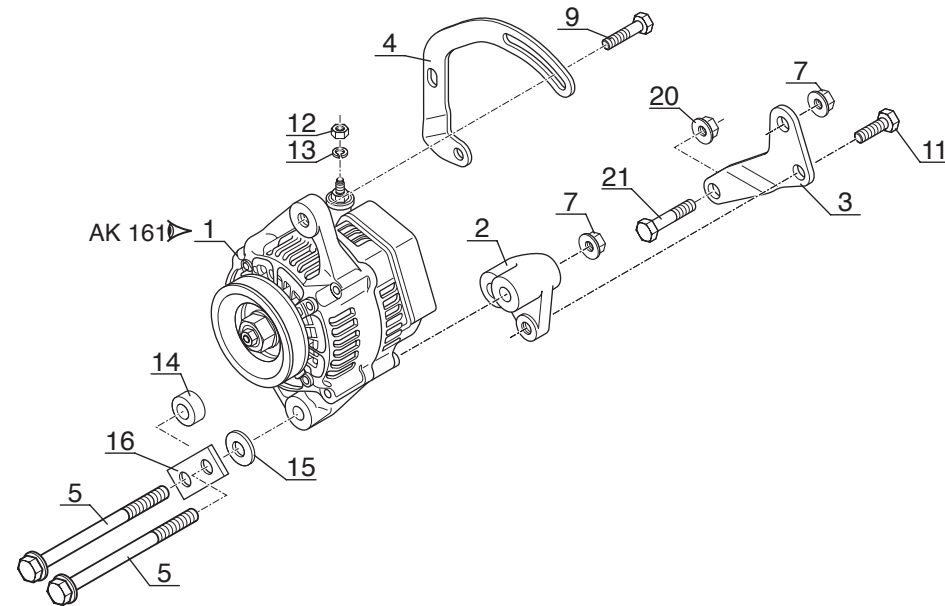

Catalogue : 270884MOD

Qté-Menge-Cant-Qty-Q.ta

AK

160

M

1

ALTERNATEUR  
WECHSELSTROMGENERATOR  
ALTERNADOR  
ALTERNATOR  
ALTERNATORE

1- 270884MOD 11-  
2- 12-  
3- 13-  
4- 14-  
5- 15-  
6- 16-  
7- 17-  
8- 18-  
9- 19-  
10- 20-

Rep Hinw Fig Item Rif	Numéro Teil-Nr Numero Part-Nr Part-Nr	Désignation Bezeichnung Descripcion Description Descrizione	1 2 3 4 5 6 7 8 9 10 11 12 13 14 15 16 17 18 19 20																			
			1	2	3	4	5	6	7	8	9	10	11	12	13	14	15	16	17	18	19	20
1	747985	Alternateur Alternador Alternatore - Wechselstromgenerator - Alternator -	1																			
2	747986	Support Soporte Supporto - Halter - Bracket -	1																			
3	747987	Support Soporte Supporto - Halter - Bracket -	1																			
4	747988	Tendeur Tensor Tenditore - Spanner - Stretcher -	1																			
5	823744	Vis Tornillo Vite - Schraube - Screw -	2																			
7	747989	Ecrou Tuerca Dado - Mutter - Nut -	2																			
9	706307	Vis Tornillo Vite - Schraube - Screw -	1																			
11	565297	Vis Tornillo Vite - Schraube - Screw -	1																			
12	565148	Ecrou Tuerca Dado - Mutter - Nut -	1																			
13	565355	Rondelle Arandela Rondella - Unterlegscheibe - Washer -	1																			
14	747990	Entretoise Separador Distanziale - Querstrebe - Spacer -	1																			

+





**AK 161**

POUR MOTEUR  
FÜR MOTOR  
PARA MOTOR  
FOR ENGINE  
PER MOTORE

□ Type : V2403-M-T-3EB-MNT-1  
□ Ref : 270 884

ALTERNATEUR  
WECHSELSTROMGENERATOR  
ALTERNADOR  
ALTERNATOR  
ALTERNATORE

MH 20-4 T BUGGIE S2-E3  
MH 25-4 T BUGGIE S2-E3  
MSI 20 / 25 / 30 / 35 T S2-E3  
MSI 20 / 25 / 30 / 35 T BUGGIE S2-E3

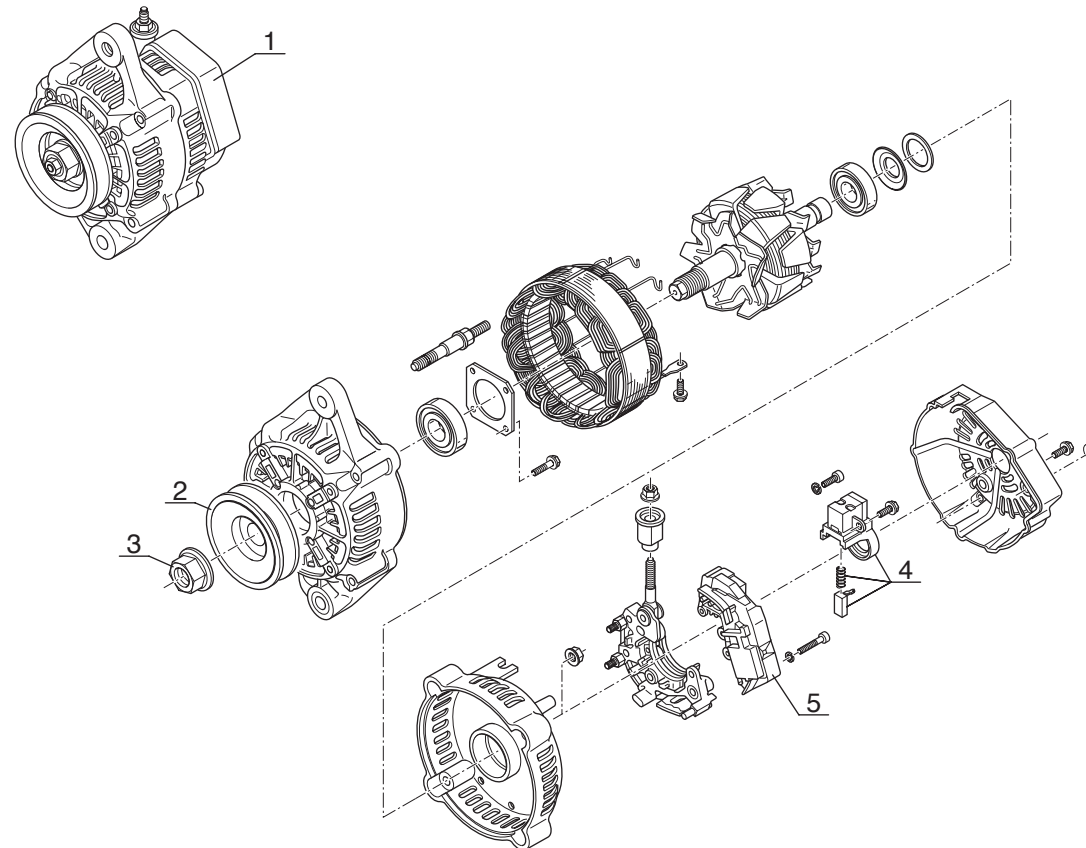



**Catalogue : 270884MOD**

1

ALTERNATEUR  
 WECHSELSTROMGENERATOR  
 ALTERNADOR  
 ALTERNATOR  
 ALTERNATORE

Qté-Menge-Cant-Qty-Q.ta

AK

161

M

1-	270884MOD	11-
2-		12-
3-		13-
4-		14-
5-		15-
6-		16-
7-		17-
8-		18-
9-		19-
10-		20-

Rep Hinw Fig Item Rif	Numéro Teil-Nr Numero Part-Nr Part-Nr	Désignation Bezeichnung Descripcion Description Descrizione
1	747996	Alternateur Alternador Alternatore - Wechselstromgenerator - Alternator -
2	747997	Poulie Polea Puleggia - Riemen - Pulley -
3	747998	Ecrou Tuerca Dado - Mutter - Nut -
4	565235	Support balai Soporte escoba Supporto spazzola - Bürste träger - Brush bracket -
5	748010	Régulateur Regulador Regulatore - Regler - Regulator -

1	2	3	4	5	6	7	8	9	10	11	12	13	14	15	16	17	18	19	20
1																			
1																			
1																			
1																			
1																			

AK 162

POUR MOTEUR  
FÜR MOTOR  
PARA MOTOR  
FOR ENGINE  
PER MOTORE

□ Type : V2403-M-T-3EB-MNT-1  
□ Ref : 270 884

COLLECTEUR D' ADMISSION  
ANSAUGLEITUNG  
COLECTOR DE ADMISION  
INTAKE MANIFOLD  
COLLETTORE AMMISSIONE

MH 20-4 T BUGGIE S2-E3  
MH 25-4 T BUGGIE S2-E3  
MSI 20 / 25 / 30 / 35 T S2-E3  
MSI 20 / 25 / 30 / 35 T BUGGIE S2-E3

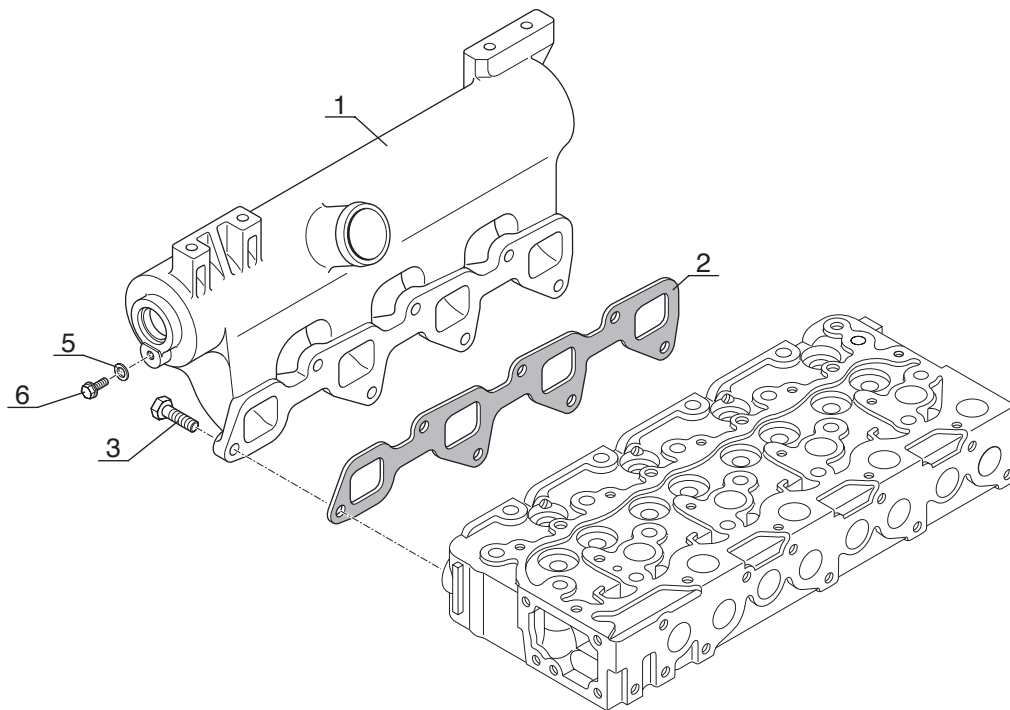



**AK 163**

POUR MOTEUR  
FÜR MOTOR  
PARA MOTOR  
FOR ENGINE  
PER MOTORE

□ Type : V2403-M-T-3EB-MNT-1  
□ Ref : 270 884

COLLECTEUR D' ECHAPPEMENT  
AUSPUFFSAMMELROHR  
COLECTOR DE ESCAPE  
EXHAUST MANIFOLD  
COLLETTORE DI SCARICO

MH 20-4 T BUGGIE S2-E3  
MH 25-4 T BUGGIE S2-E3  
MSI 20 / 25 / 30 / 35 T S2-E3  
MSI 20 / 25 / 30 / 35 T BUGGIE S2-E3

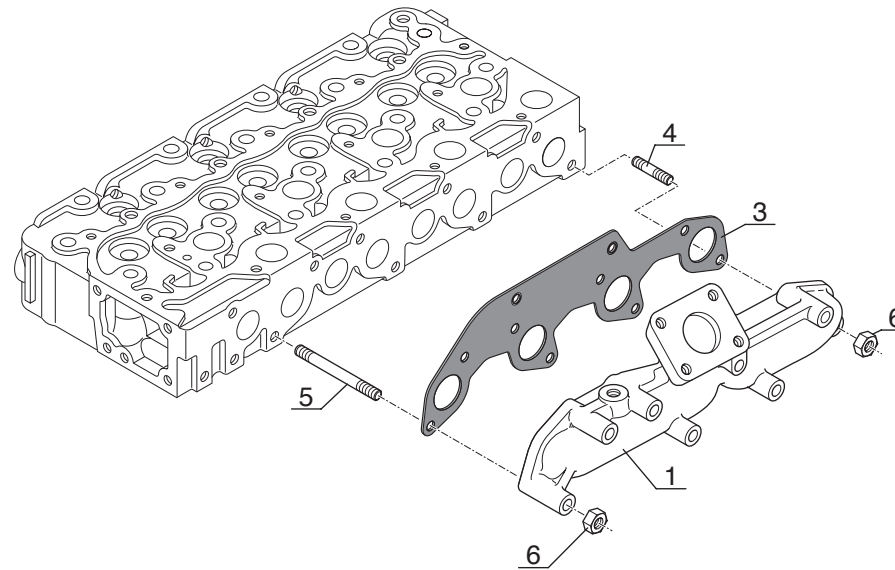

**Catalogue : 270884MOD**

1

COLLECTEUR D'ECHAPPEMENT  
 AUSPUFFSAMMELROHR  
 COLECTOR DE ESCAPE  
 EXHAUST MANIFOLD  
 COLLETTORE DI SCARICO

Qté-Menge-Cant-Qty-Q.ta

AK

163

M

1-	270884MOD	11-
2-		12-
3-		13-
4-		14-
5-		15-
6-		16-
7-		17-
8-		18-
9-		19-
10-		20-

Rep Hinw Fig Item Rif	Numéro Teil-Nr Numero Part-Nr Part-Nr	Désignation Bezeichnung Descripcion Description Descrizione
1	748025	Collecteur d'échappement - Auspuffsammelrohr Colector de escape - Exhaust manifold Collettore di scarico -
3	748026	Joint plat - Dichtung Junta plana - Gasket Guarnizióne -
4	748027	Goujon - Stiftschraube Espárrago - Stud-bolt Prigioniero -
5	823592	Goujon - Stiftschraube Espárrago - Stud-bolt Prigioniero -
6	823716	Ecrou - Mutter Tuerca - Nut Dado -

1	2	3	4	5	6	7	8	9	10	11	12	13	14	15	16	17	18	19	20
1																			
1																			
7																			
1																			
8																			

AK 164

POUR MOTEUR  
FÜR MOTOR  
PARA MOTOR  
FOR ENGINE  
PER MOTORE

□ Type : V2403-M-T-3EB-MNT-1  
□ Ref : 270 884

TURBO-COMPRESSEUR (Détails)  
TURBOKOMPRESSOR (Einzelteile)  
TURBOCOMPRESSOR (Detalles)  
TURBOCHARGER (Details)  
TURBOCOMPRESSORE (Dettaglio)

MH 20-4 T BUGGIE S2-E3  
MH 25-4 T BUGGIE S2-E3  
MSI 20 / 25 / 30 / 35 T S2-E3  
MSI 20 / 25 / 30 / 35 T BUGGIE S2-E3

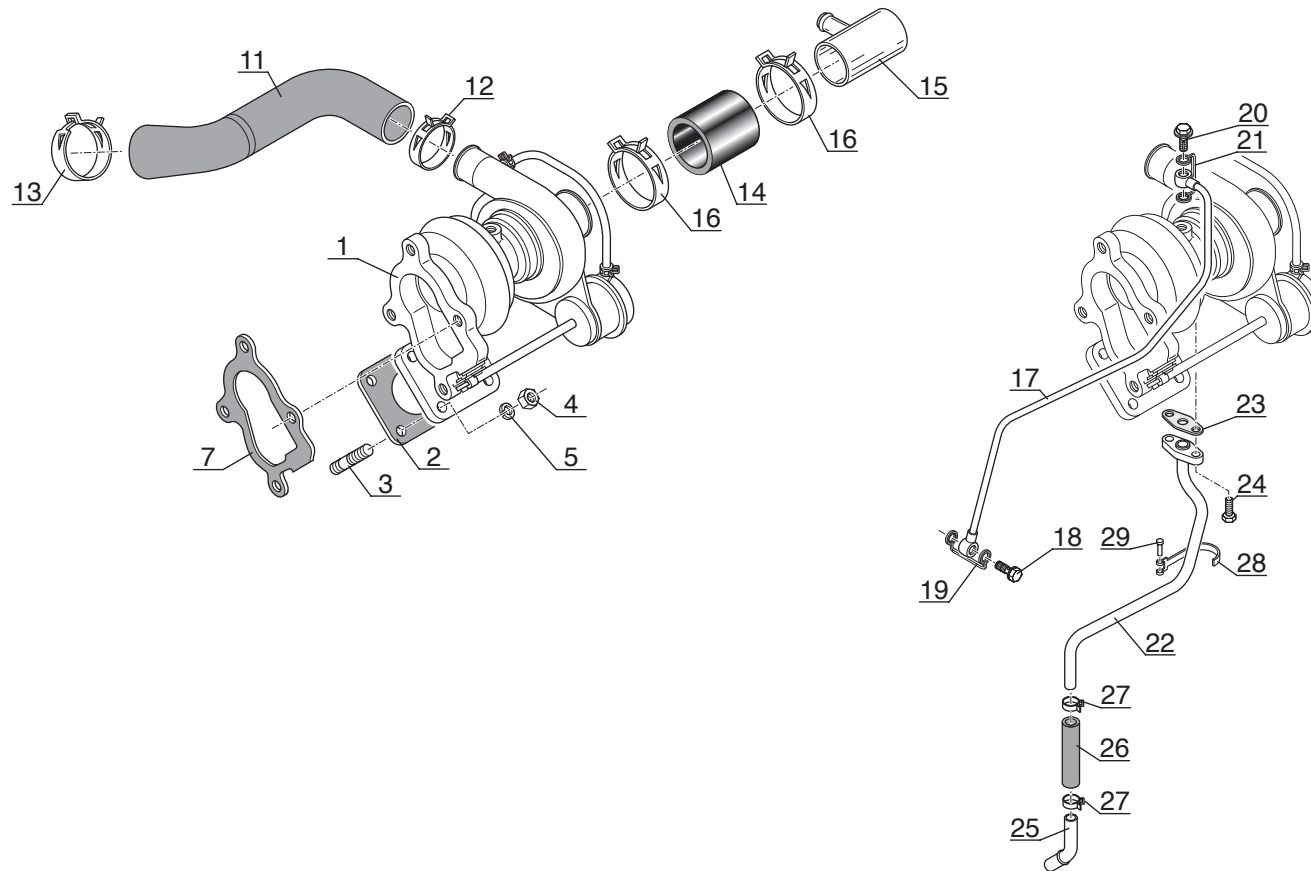

Catalogue : 270884MOD

Qté-Menge-Cant-Qty-Q.ta

AK

164

M

1

TURBO-COMPRESSEUR (Détails)  
 TURBOKOMPRESSOR (Einzelteile)  
 TURBOCOMPRESOR (Detalles)  
 TURBOCHARGER (Details)  
 TURBOCOMPRESSORE (Dettaglio)

1- 270884MOD 11-  
 2- 12-  
 3- 13-  
 4- 14-  
 5- 15-  
 6- 16-  
 7- 17-  
 8- 18-  
 9- 19-  
 10- 20-

Rep Hinw Fig Item Rif	Numéro Teil-Nr Numero Part-Nr Part-Nr	Désignation Bezeichnung Descripcion Description Descrizione	Qté-Menge-Cant-Qty-Q.ta																			
			1	2	3	4	5	6	7	8	9	10	11	12	13	14	15	16	17	18	19	20
1	748028	Turbo-compresseur Turbo compresor Turbocompressore	- Turbolader - Turbocharger -	1																		
2	748029	Joint plat Junta plana Guarnizióne	- Dichtung - Gasket -	1																		
3	748030	Goujon Espárrago Prigioniero	- Stiftschraube - Stud-bolt -	4																		
4	565299	Ecrou Tuerca Dado	- Mutter - Nut -	4																		
5	600093	Rondelle Arandela Rondella	- Unterlegscheibe - Washer -	4																		
7	748032	Joint plat Junta plana Guarnizióne	- Dichtung - Gasket -	1																		
11	748034	Durit Tubo flexible Manicotto	- Schlauch - Hose -	1																		
12	748035	Collier Abrazadera Fascetta	- Spannschelle - Clamp -	1																		
13	748036	Collier Abrazadera Fascetta	- Spannschelle - Clamp -	1																		
14	748037	Durit Tubo flexible Manicotto	- Schlauch - Hose -	1																		
15	748038	Collecteur Colector Collettore	- Leitung - Pipe -	1																		

+





**Catalogue : 270884MOD**

3

TURBO-COMPRESSEUR (Détails)  
 TURBOKOMPRESSOR (Einzelteile)  
 TURBOCOMPRESOR (Detalles)  
 TURBOCHARGER (Details)  
 TURBOCOMPRESSORE (Dettaglio)

Qté-Menge-Cant-Qty-Q.ta

AK

164

M

1-	270884MOD	11-
2-		12-
3-		13-
4-		14-
5-		15-
6-		16-
7-		17-
8-		18-
9-		19-
10-		20-

Rep Hinw Fig Item Rif	Numéro Teil-Nr Numero Part-Nr Part-Nr	Désignation Bezeichnung Descripcion Description Descrizione
27	823676	Collier - Spannschelle Abrazadera - Clamp Fascetta -
28	748048	Attache - Klammer Atadura - Clip Innesto -
29	748049	Goupille - Stift Pasador - Pin Spina -

1	2	3	4	5	6	7	8	9	10	11	12	13	14	15	16	17	18	19	20
2																			
1																			
1																			

AK 165

POUR MOTEUR  
FÜR MOTOR  
PARA MOTOR  
FOR ENGINE  
PER MOTORE

□ Type : V2403-M-T-3EB-MNT-1  
□ Ref : 270 884

CIRCUIT COMBUSTIBLE  
BRENNSTOFFKREIS  
CIRCUITO COMBUSTIBILE  
FUEL CIRCUIT  
CIRCUITO COMBUSTIBILE

MH 20-4 T BUGGIE S2-E3  
MH 25-4 T BUGGIE S2-E3  
MSI 20 / 25 / 30 / 35 T S2-E3  
MSI 20 / 25 / 30 / 35 T BUGGIE S2-E3

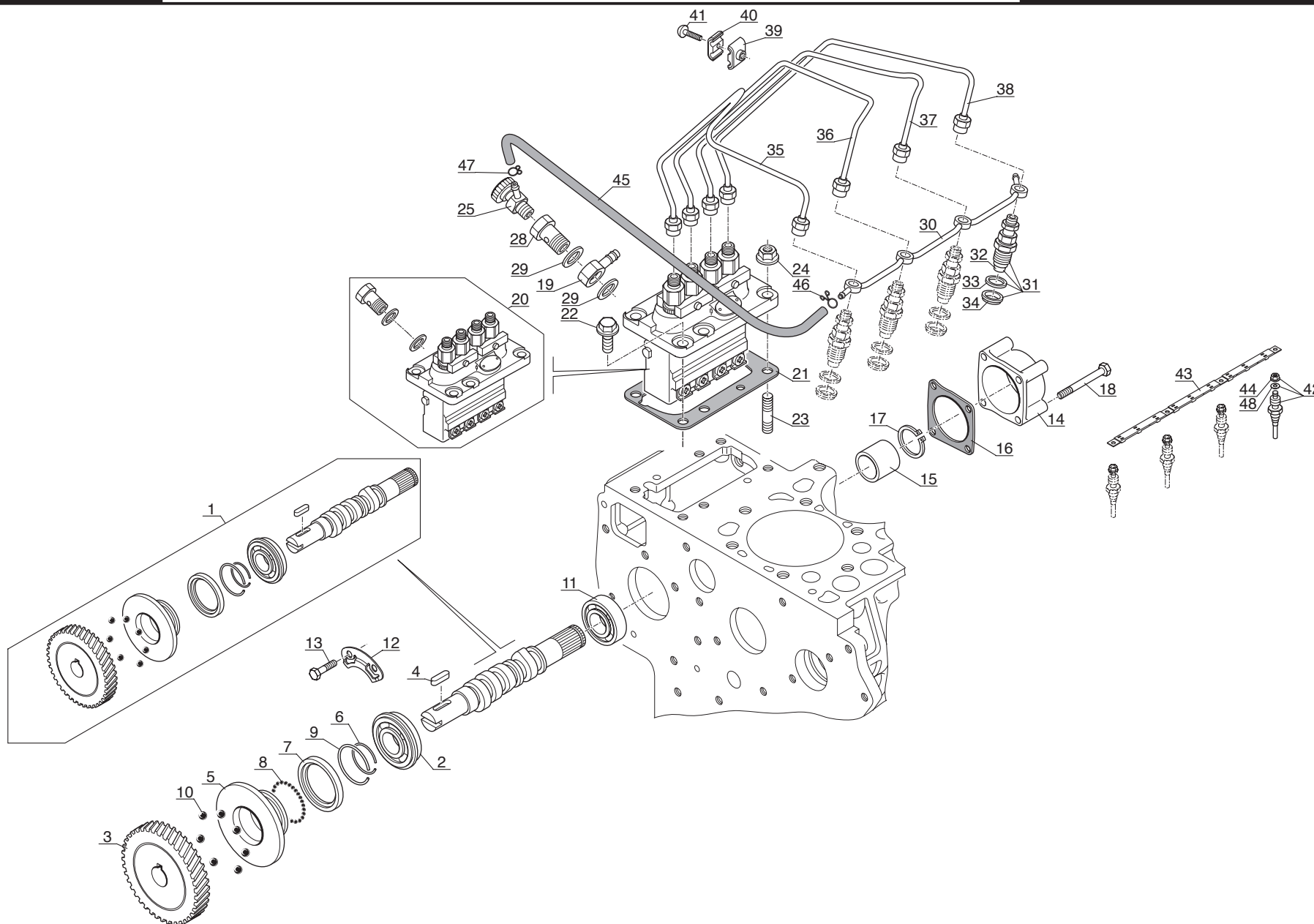

Catalogue : 270884MOD

Qté-Menge-Cant-Qty-Q.ta

AK

165

M

1

CIRCUIT COMBUSTIBLE  
BRENNSTOFFKREIS  
CIRCUITO COMBUSTIBILE  
FUEL CIRCUIT  
CIRCUITO COMBUSTIBILE

1- 270884MOD 11-  
2- 12-  
3- 13-  
4- 14-  
5- 15-  
6- 16-  
7- 17-  
8- 18-  
9- 19-  
10- 20-

Rep Hinw Fig Item Rif	Numéro Teil-Nr Numero Part-Nr Part-Nr	Désignation Bezeichnung Descripcion Descrizione	1	2	3	4	5	6	7	8	9	10	11	12	13	14	15	16	17	18	19	20
1	747972	Arbre à cames complet Arbol de levas completo Albero a camme completo	- Kompletter Nockenwelle - Complete camshaft -	1																		
2	823554	Roulement à billes Rodamiento de bola Cuscinetto di sfera	- Lager Kugel - Bearing Ball -	1																		
3	823555	Pignon Piñón Ingranaggio	- Zahnrad - Gear -	1																		
4	823556	Clavette Chaveta Chiavetta	- Keil - Key -	1																		
5	823557	Bague Anillo Anello	- Büchse - Bushing -	1																		
6	823558	Circlips Aro retén Anello elastico	- Sicherungsring - Circlip -	1																		
7	823559	Cage de roulement Caja Gabbia molla	- Lagergehaeuse - Cage -	1																		
8	823560	Bille Bola Sfera	- Kugel - Ball -	39																		
9	823561	Circlips Aro retén Anello elastico	- Sicherungsring - Circlip -	1																		
10	823562	Bille Bola Sfera	- Kugel - Ball -	7																		
11	823563	Roulement Rodamiento Cuscinetto	- Lager - Bearing -	1																		

+

Catalogue : 270884MOD

Qté-Menge-Cant-Qty-Q.ta

AK

165

M

2

CIRCUIT COMBUSTIBLE  
BRENNSTOFFKREIS  
CIRCUITO COMBUSTIBILE  
FUEL CIRCUIT  
CIRCUITO COMBUSTIBILE

1- 270884MOD 11-  
2- 12-  
3- 13-  
4- 14-  
5- 15-  
6- 16-  
7- 17-  
8- 18-  
9- 19-  
10- 20-

Rep Hinw Fig Item Rif	Numéro Teil-Nr Numero Part-Nr Part-Nr	Désignation Bezeichnung Descripcion Description Descrizione	Qté-Menge-Cant-Qty-Q.ta																			
			1	2	3	4	5	6	7	8	9	10	11	12	13	14	15	16	17	18	19	20
12	823564	Butée Tope Battuta - Anschlag - Stop -	1																			
13	565823	Vis Tornillo Vite - Schraube - Screw -	2																			
14	823565	Couvercle Tapadera Coperchio - Deckel - Cover -	1																			
15	823566	Bague Anillo Anello - Büchse - Bushing -	1																			
16	823567	Joint Junta Guarnizióne - Dichtung - Seal -	1																			
17	823568	Circlips Aro retén Anello elastico - Sicherungsring - Circlip -	1																			
18	823569	Vis Tornillo Vite - Schraube - Screw -	4																			
19	823586	Raccord banjo Racor banjo Raccordo - Verschraubung - Banjo connection -	1																			
20	747973	Pompe d'injection Bomba de inyección Pompa iniezione - Einspritzpumpe - Injection pump -	1																			
21	823588	Cale d'épaisseur 0,20 mm Cala de espesor Spessore - Ausgleichscheibe - Shim -	X																			
21	823589	Cale d'épaisseur 0,25 mm Cala de espesor Spessore - Ausgleichscheibe - Shim -	X																			

+

Catalogue : 270884MOD

Qté-Menge-Cant-Qty-Q.ta

AK

165

M

3

CIRCUIT COMBUSTIBLE  
BRENNSTOFFKREIS  
CIRCUITO COMBUSTIBILE  
FUEL CIRCUIT  
CIRCUITO COMBUSTIBILE

1- 270884MOD 11-  
2- 12-  
3- 13-  
4- 14-  
5- 15-  
6- 16-  
7- 17-  
8- 18-  
9- 19-  
10- 20-

Rep Hinw Fig Item Rif	Numéro Teil-Nr Numero Part-Nr Part-Nr	Désignation Bezeichnung Descripcion Description Descrizione	1	2	3	4	5	6	7	8	9	10	11	12	13	14	15	16	17	18	19	20
21	823590	Cale d'épaisseur 0,30 mm Cala de espesor Spessore - Ausgleichs Scheibe - Shim -	X																			
21	823728	Cale d'épaisseur 0,175 mm Cala de espesor Spessore - Ausgleichs Scheibe - Shim -	X																			
22	823591	Vis Tornillo Vite - Schraube - Screw -	4																			
23	823592	Goujon Espárrago Prigioniero - Stiftschraube - Stud-bolt -	2																			
24	823593	Ecrou Tuerca Dado - Mutter - Nut -	2																			
25	823594	Robinet Grifo Rubinetto - Hahn - Tap -	1																			
28	823595	Vis creuse Tornillo hueco Vite cava - Hohlschraube - Hollow screw -	1																			
29	823596	Joint Junta Guarnizióne - Dichtung - Seal -	2																			
30	823607	Tubulure de retour Tobera de retorno Tubo introduzione ritorno - Rückleitung - Return pipe -	1																			
31	747976	Injecteur complet Inyector completo Atomizzatore completa - Kompletter einspritzdüse - Complete injector -	4																			
32	747977	Nez d'injecteur Inyector Iniezione - Dusenmundstück - Inyector nozzle -	4																			

+

Catalogue : 270884MOD

Qté-Menge-Cant-Qty-Q.ta

AK

165

M

4

CIRCUIT COMBUSTIBLE  
BRENNSTOFFKREIS  
CIRCUITO COMBUSTIBLE  
FUEL CIRCUIT  
CIRCUITO COMBUSTIBILE

1- 270884MOD 11-  
2- 12-  
3- 13-  
4- 14-  
5- 15-  
6- 16-  
7- 17-  
8- 18-  
9- 19-  
10- 20-

Rep Hinw Fig Item Rif	Numéro Teil-Nr Numero Part-Nr Part-Nr	Désignation Bezeichnung Descripcion Description Descrizione	Qté-Menge-Cant-Qty-Q.ta																			
			1	2	3	4	5	6	7	8	9	10	11	12	13	14	15	16	17	18	19	20
33	565400	Joint Junta Guarnizióne	- Dichtung - Seal -	4																		
34	565401	Joint Junta Guarnizióne	- Dichtung - Seal -	4																		
35	747978	Tuyau d'injection Tubo de inyección Tubo iniezione	- Einspritz leitung - Injection pipe -	1																		
36	747979	Tuyau d'injection Tubo de inyección Tubo iniezione	- Einspritz leitung - Injection pipe -	1																		
37	747980	Tuyau d'injection Tubo de inyección Tubo iniezione	- Einspritz leitung - Injection pipe -	1																		
38	747981	Tuyau d'injection Tubo de inyección Tubo iniezione	- Einspritz leitung - Injection pipe -	1																		
39	565405	Collier Abrazadera Fascetta	- Spannschelle - Clamp -	3																		
40	565406	Collier Abrazadera Fascetta	- Spannschelle - Clamp -	3																		
41	565407	Vis Tornillo Vite	- Schraube - Screw -	3																		
42	823616	Bougie de préchauffage Bujia de precalentamiento Termostarter	- Glühkerze - Heating plug -	4																		
43	823617	Barrette de connexion Regleta Barreta di collegamento	- Befestigungskeil - Finger bar -	1																		

+

**Catalogue : 270884MOD**

**5**

CIRCUIT COMBUSTIBLE  
 BRENNSTOFFKREIS  
 CIRCUITO COMBUSTIBLE  
 FUEL CIRCUIT  
 CIRCUITO COMBUSTIBILE

Qté-Menge-Cant-Qty-Q.ta

**AK**

**165**

**M**

1-	270884MOD	11-
2-		12-
3-		13-
4-		14-
5-		15-
6-		16-
7-		17-
8-		18-
9-		19-
10-		20-

Rep Hinw Fig Item Rif	Numéro Teil-Nr Numero Part-Nr Part-Nr	Désignation Bezeichnung Descripcion Descrizione
44	706304	Ecrou - Mutter Tuerca - Nut Dado -
45	823608	Tuyau - Schlauch Tubo - Hose Tubo -
46	565398	Collier - Spannschelle Abrazadera - Clamp Fascetta -
47	747982	Collier - Spannschelle Abrazadera - Clamp Fascetta -
48	747983	Rondelle - Unterlegscheibe Arandela - Washer Rondella -

1	2	3	4	5	6	7	8	9	10	11	12	13	14	15	16	17	18	19	20
4																			
1																			
1																			
1																			
4																			

AK 166

POUR MOTEUR  
FÜR MOTOR  
PARA MOTOR  
FOR ENGINE  
PER MOTORE

□ Type : V2403-M-T-3EB-MNT-1  
□ Ref : 270 884

CIRCUIT COMBUSTIBLE  
BRENNSTOFFKREIS  
CIRCUITO COMBUSTIBILE  
FUEL CIRCUIT  
CIRCUITO COMBUSTIBILE

MH 20-4 T BUGGIE S2-E3  
MH 25-4 T BUGGIE S2-E3  
MSI 20 / 25 / 30 / 35 T S2-E3  
MSI 20 / 25 / 30 / 35 T BUGGIE S2-E3

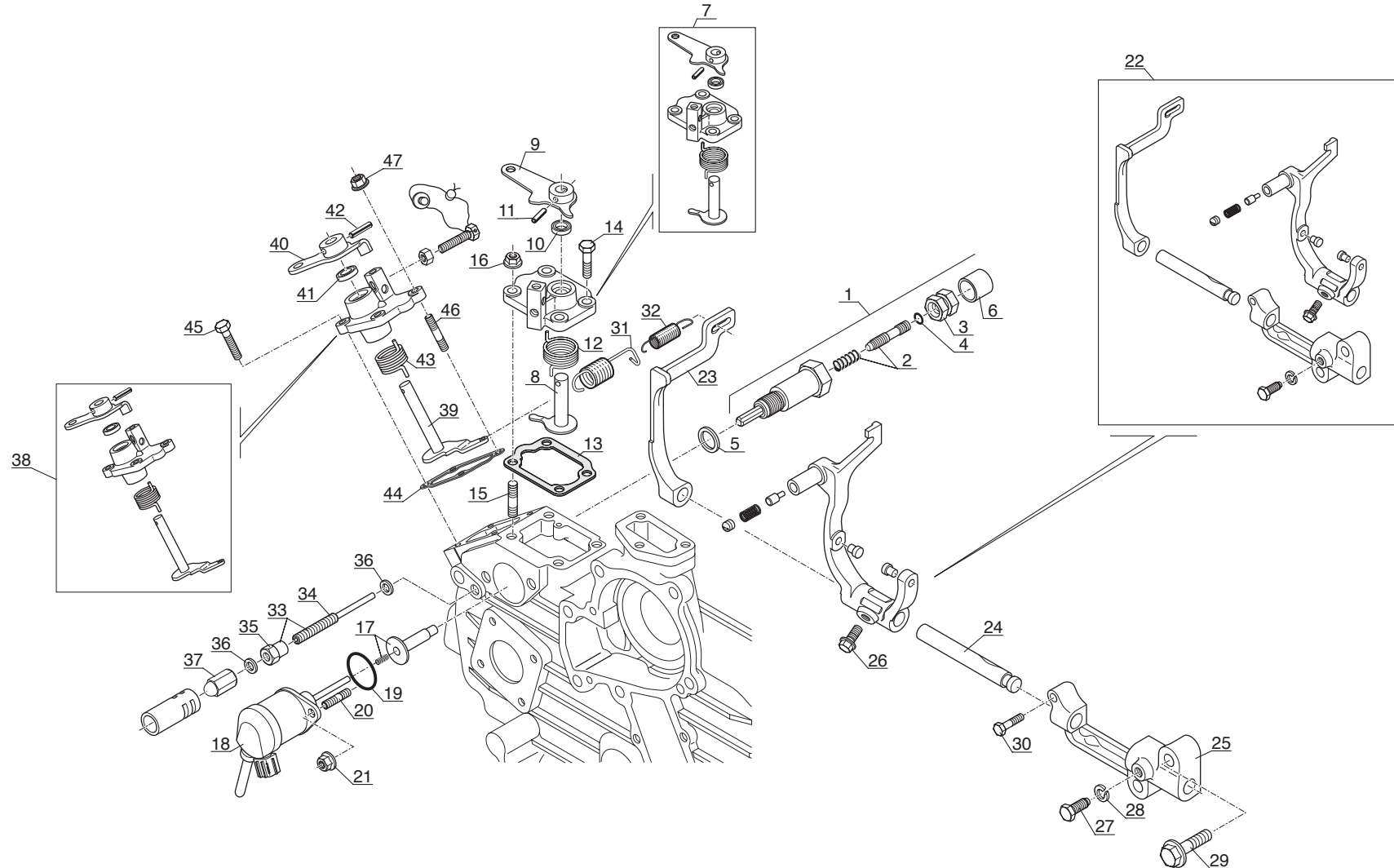



Catalogue : 270884MOD

Qté-Menge-Cant-Qty-Q.ta

AK

166

M

1

CIRCUIT COMBUSTIBLE  
BRENNSTOFFKREIS  
CIRCUITO COMBUSTIBILE  
FUEL CIRCUIT  
CIRCUITO COMBUSTIBILE

1- 270884MOD 11-  
2- 12-  
3- 13-  
4- 14-  
5- 15-  
6- 16-  
7- 17-  
8- 18-  
9- 19-  
10- 20-

Rep Hinw Fig Item Rif	Numéro Teil-Nr Numero Part-Nr Part-Nr	Désignation Bezeichnung Descripcion Description Descrizione	1	2	3	4	5	6	7	8	9	10	11	12	13	14	15	16	17	18	19	20
1	823570	Vis de réglage Tornillo de regulación Vite di regolaggio - Stellschraube - Adjusting screw -	1																			
2	823571	Vis de réglage Tornillo de regulación Vite di regolaggio - Stellschraube - Adjusting screw -	1																			
3	823572	Ecrou Tuerca Dado - Mutter - Nut -	1																			
4	823573	Joint torique Junta tórica Anello OR - "O" ring - "O" ring -	1																			
5	823574	Joint Junta Guarnizióne - Dichtung - Seal -	1																			
6	823575	Bouchon Tapón Tappo - Stopfen - Plug -	1																			
7	823576	Levier d'arrêt moteur Palanca de parada del motor Leva arresto motore - Motorabstellhebel - Engine stop lever -	1																			
8	823577	Axe de renvoi Eje de cambio Perno di rinvio - Vorgelege bolzen - Countershaft -	1																			
9	823578	Levier Palanca Leva - Hebel - Lever -	1																			
10	823579	Joint Junta Guarnizióne - Dichtung - Seal -	1																			
11	565336	Goupille Pasador Spina - Stift - Pin -	1																			

+

Catalogue : 270884MOD

Qté-Menge-Cant-Qty-Q.ta

AK

166

M

2

CIRCUIT COMBUSTIBLE  
BRENNSTOFFKREIS  
CIRCUITO COMBUSTIBLE  
FUEL CIRCUIT  
CIRCUITO COMBUSTIBILE

1- 270884MOD 11-  
2- 12-  
3- 13-  
4- 14-  
5- 15-  
6- 16-  
7- 17-  
8- 18-  
9- 19-  
10- 20-

Rep Hinw Fig Item Rif	Numéro Teil-Nr Numero Part-Nr Part-Nr	Désignation Bezeichnung Descripcion Description Descrizione	Qté-Menge-Cant-Qty-Q.ta																			
			1	2	3	4	5	6	7	8	9	10	11	12	13	14	15	16	17	18	19	20
12	823580	Ressort Muelle Molla - Feder - Spring -	1																			
13	823581	Joint Junta Guarnizióne - Dichtung - Seal -	1																			
14	565031	Vis Tornillo Vite - Schraube - Screw -	2																			
15	565846	Goujon Espárrago Prigioniero - Stiftschraube - Stud-bolt -	2																			
16	706822	Ecrou Tuerca Dado - Mutter - Nut -	2																			
17	823583	Guide Guía Guida - Führungs - Guide -	1																			
18	823584	Solénoïde Solenoid Solenoid - Solenoid - Solenoid -	1																			
19	823585	Joint torique Junta tórica Anello OR - "O" ring - "O" ring -	1																			
20	565846	Goujon Espárrago Prigioniero - Stiftschraube - Stud-bolt -	2																			
21	746888	Ecrou Tuerca Dado - Mutter - Nut -	2																			
22	747974	Levier complet Palanca completa Leva completa - Kompletter hebel - Complete lever -	1																			

+



Catalogue : 270884MOD

Qté-Menge-Cant-Qty-Q.ta

AK

166

M

4

CIRCUIT COMBUSTIBLE  
BRENNSTOFFKREIS  
CIRCUITO COMBUSTIBLE  
FUEL CIRCUIT  
CIRCUITO COMBUSTIBILE

1- 270884MOD 11-  
2- 12-  
3- 13-  
4- 14-  
5- 15-  
6- 16-  
7- 17-  
8- 18-  
9- 19-  
10- 20-

Rep Hinw Fig Item Rif	Numéro Teil-Nr Numero Part-Nr Part-Nr	Désignation Bezeichnung Descripcion Description Descrizione	Qté-Menge-Cant-Qty-Q.ta																			
			1	2	3	4	5	6	7	8	9	10	11	12	13	14	15	16	17	18	19	20
34	823601	Vis de réglage Tornillo de regulación Vite di regolaggio	- Stellschraube - Adjusting screw -	1																		
35	823602	Ecrou Tuerca Dado	- Mutter - Nut -	1																		
36	565288	Joint Junta Guarnizióne	- Dichtung - Seal -	2																		
37	565859	Ecrou Tuerca Dado	- Mutter - Nut -	1																		
38	823603	Kit régulateur de vitesse Kit regulador de velocidad Kit regolatore	- Drehzahlregler kit - Speed governor kit -	1																		
39	823604	Axe de renvoi Eje de cambio Perno di rinvio	- Vorgelege bolzen - Countershaft -	1																		
40	823605	Levier d'accélérateur Palanca de acelerador Leva acceleratore	- Gashebel - Accelerator lever -	1																		
41	823579	Joint Junta Guarnizióne	- Dichtung - Seal -	1																		
42	565336	Goupille Pasador Spina	- Stift - Pin -	1																		
43	823580	Ressort Muelle Molla	- Feder - Spring -	1																		
44	823581	Joint Junta Guarnizióne	- Dichtung - Seal -	1																		

+

**Catalogue : 270884MOD**

**5**

CIRCUIT COMBUSTIBLE  
 BRENNSTOFFKREIS  
 CIRCUITO COMBUSTIBLE  
 FUEL CIRCUIT  
 CIRCUITO COMBUSTIBILE

Qté-Menge-Cant-Qty-Q.ta

**AK**

**166**

**M**

1-	270884MOD	11-
2-		12-
3-		13-
4-		14-
5-		15-
6-		16-
7-		17-
8-		18-
9-		19-
10-		20-

Rep Hinw Fig Item Rif	Numéro Teil-Nr Numero Part-Nr Part-Nr	Désignation Bezeichnung Descripcion Description Descrizione
45	565031	Vis Tornillo Vite - Schraube - Screw -
46	565846	Goujon Espárrago Prigioniero - Stiftschraube - Stud-bolt -
47	706822	Ecrou Tuerca Dado - Mutter - Nut -

1	2	3	4	5	6	7	8	9	10	11	12	13	14	15	16	17	18	19	20	
2																				
2																				
2																				



**REDUCTEUR DE PRESSION**  
**DRUCKMINDERVENTIL**  
**REDUCTOR DE PRESION**  
**PRESSURE REDUCING VALVE**  
**REDUTTORE DI PRESSIONE**

BC 50

POUR REDUCTEUR DE PRESSION  
FÜR DRUCKMINDERVENTIL  
PARA REDUCTOR DE PRESION  
FOR PRESSURE REDUCING VALVE  
PER REDUTTORE DI PRESSIONE  
□ □ 1 TH7 Z53-10

REDUCTEUR DE PRESSION  
DRUCKMINDERVENTIL  
REDUCTOR DE PRESION  
PRESSURE REDUCING VALVE  
REDUTTORE DI PRESSIONE

MH 20-4 T BUGGIE S2-E3  
MH 25-4 T BUGGIE S2-E3

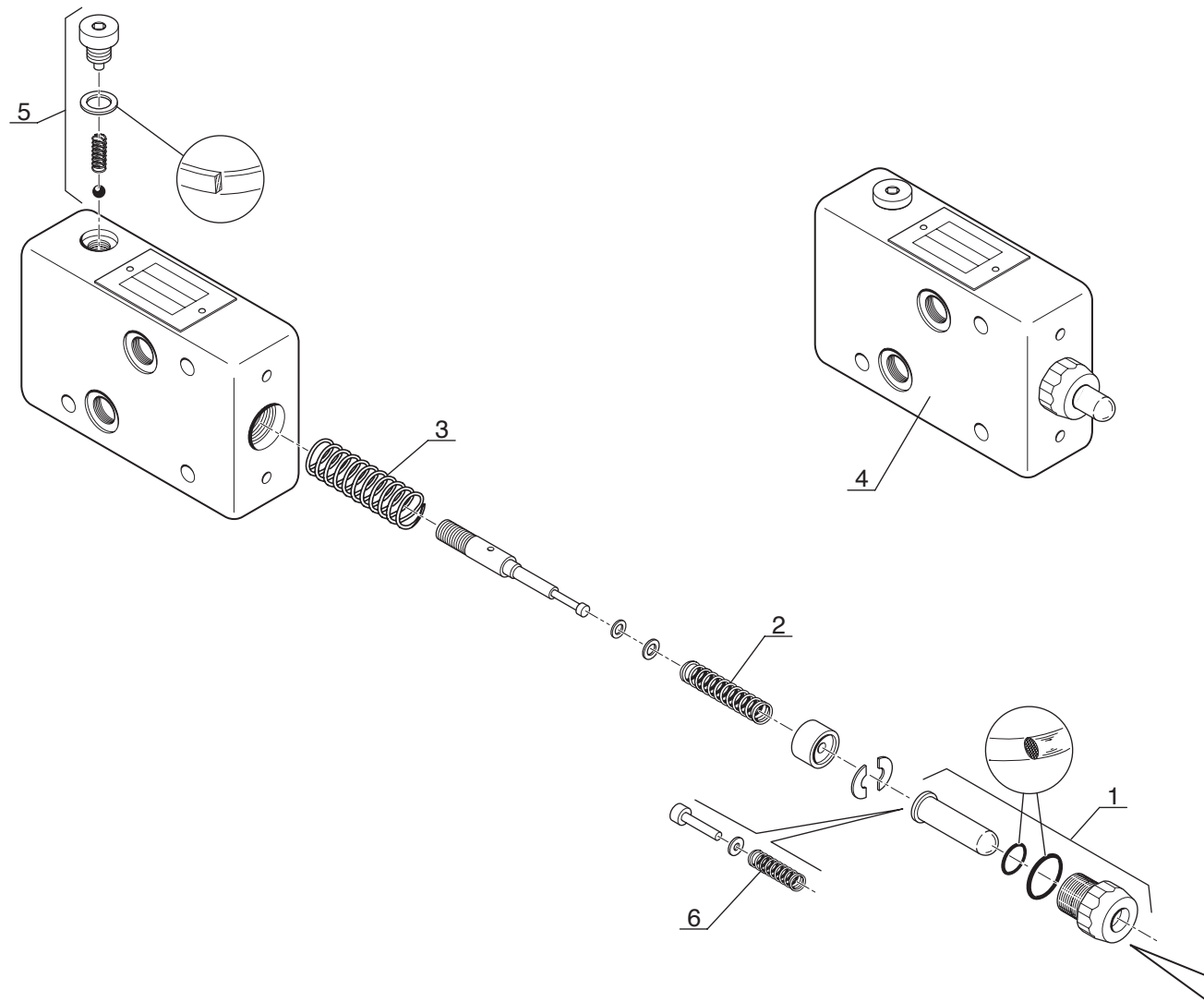

COUPLE DE SERRAGE: 3m. daN  
ANZIEHDREHMOMENTE: 3m. daN  
PAR DE APRIETE: 3m. daN  
TIGHTENING TORQUES: 3m. daN  
COPPIA DI SERRAGGIO: 3m. daN



**Catalogue : 75498MOD**

1

REDUCTEUR DE PRESSION  
 DRUCKMINDERVENTIL  
 REDUCTOR DE PRESION  
 PRESSURE REDUCING VALVE  
 RIDUTTORE DI PRESSIONE

Qté-Menge-Cant-Qty-Q.ta

BC

50

M

1- 75498MOD	11-
2-	12-
3-	13-
4-	14-
5-	15-
6-	16-
7-	17-
8-	18-
9-	19-
10-	20-

Rep Hinw Fig Item Rif	Numéro Teil-Nr Numero Part-Nr Part-Nr	Désignation Bezeichnung Descripcion Description Descrizione	Qté-Menge-Cant-Qty-Q.ta																			
			1	2	3	4	5	6	7	8	9	10	11	12	13	14	15	16	17	18	19	20
1	403429	Ensemble guide et poussoir - Fadenführer mit drücker Conjunto guiá con cebador - Pusher with its guide Kit guida e spintore -	1																			
2	403430	Ressort de tarage - Feder Resorte per la determinaci3n de la tara Spring taring Molla -	1																			
3	403431	Ressort de rappel - Feder Resorte de llamada - Return spring Molla -	1																			
4	75498	Réducteur de pression complet - Komplette inching ventil Valvulá de inching completa - Complete inching valve Riduttore di pressione completo	1																			
5	404484	Clapet anti-retour - Gegendruckventil Válvula antiretorno - Back pressure valve Valvola anti-ritorno -	1																			
6	403432	Ressort additionnel - Feder Muelle - Spring Molla -	1																			

BC 99

POUR REDUCTEUR DE PRESSION  
FÜR DRUCKMINDERVENTIL  
PARA REDUCTOR DE PRESION  
FOR PRESSURE REDUCING VALVE  
PER REDUTTORE DI PRESSIONE  
□ 1 TH7 Z90-10

REDUCTEUR DE PRESSION  
DRUCKMINDERVENTIL  
REDUCTOR DE PRESION  
PRESSURE REDUCING VALVE  
REDUTTORE DI PRESSIONE

MH 20-4 T BUGGIE S2-E3  
MH 25-4 T BUGGIE S2-E3  
MSI 20 / 25 / 30 / 35 T S2-E3  
MSI 20 / 25 / 30 / 35 T BUGGIE S2-E3

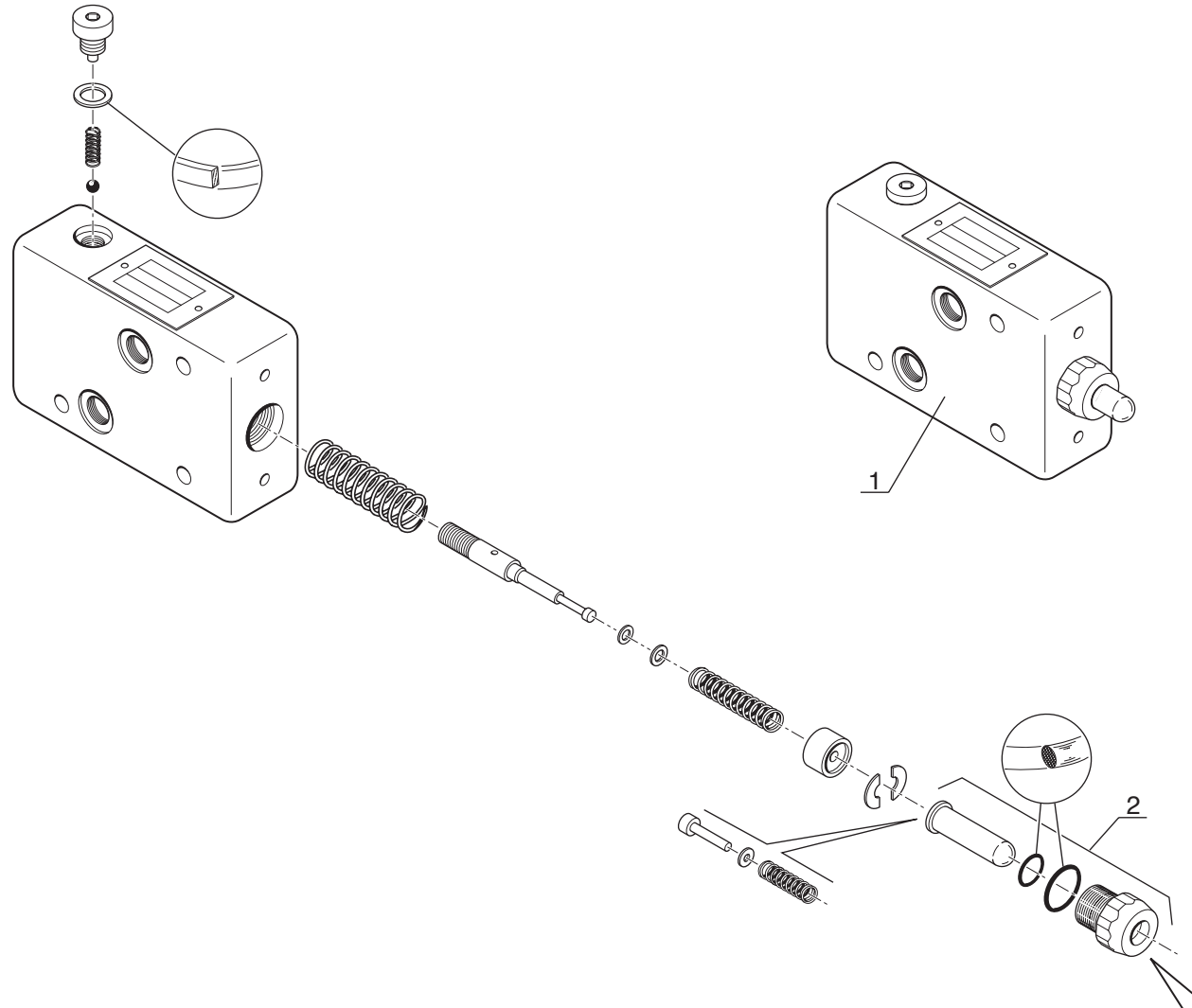

COUPLE DE SERRAGE: 3m. daN  
ANZIEHDREHMOMENTE: 3m. daN  
PAR DE APRIETE: 3m. daN  
TIGHTENING TORQUES: 3m. daN  
COPPIA DI SERRAGGIO: 3m. daN

**Catalogue : 201559MOD**

1

REDUCTEUR DE PRESSION  
 DRUCKMINDERVENTIL  
 REDUCTOR DE PRESION  
 PRESSURE REDUCING VALVE  
 RIDUTTORE DI PRESSIONE

Qté-Menge-Cant-Qty-Q.ta

BC

99

M

1-	201559MOD	11-
2-		12-
3-		13-
4-		14-
5-		15-
6-		16-
7-		17-
8-		18-
9-		19-
10-		20-

Rep Hinw Fig Item Rif	Numéro Teil-Nr Numero Part-Nr Part-Nr	Désignation Bezeichnung Descripcion Description Descrizione
-----------------------------------	---	---

1	2	3	4	5	6	7	8	9	10	11	12	13	14	15	16	17	18	19	20
---	---	---	---	---	---	---	---	---	----	----	----	----	----	----	----	----	----	----	----

1	201559	Réducteur de pression complet - Komplette inching ventil Valvulá de inching completa - Complete inching valve Riduttore di pressione completo
2	548774	Ensemble guide et poussoir - Fadenführer mit drücker Conjunto guiá con cebador - Pusher with its guide Kit guida e spintore -

1																				
1																				

**BC 166**

POUR REDUCTEUR DE PRESSION  
FÜR DRUCKMINDERVENTIL  
PARA REDUCTOR DE PRESION  
FOR PRESSURE REDUCING VALVE  
PER REDUTTORE DI PRESSIONE  
□ □ 1 TH7 Z106-10

REDUCTEUR DE PRESSION  
DRUCKMINDERVENTIL  
REDUCTOR DE PRESION  
PRESSURE REDUCING VALVE  
REDUTTORE DI PRESSIONE

MH 20-4 T BUGGIE S2-E3  
MH 25-4 T BUGGIE S2-E3  
MSI 20 / 25 / 30 / 35 T S2-E3  
MSI 20 / 25 / 30 / 35 T BUGGIE S2-E3

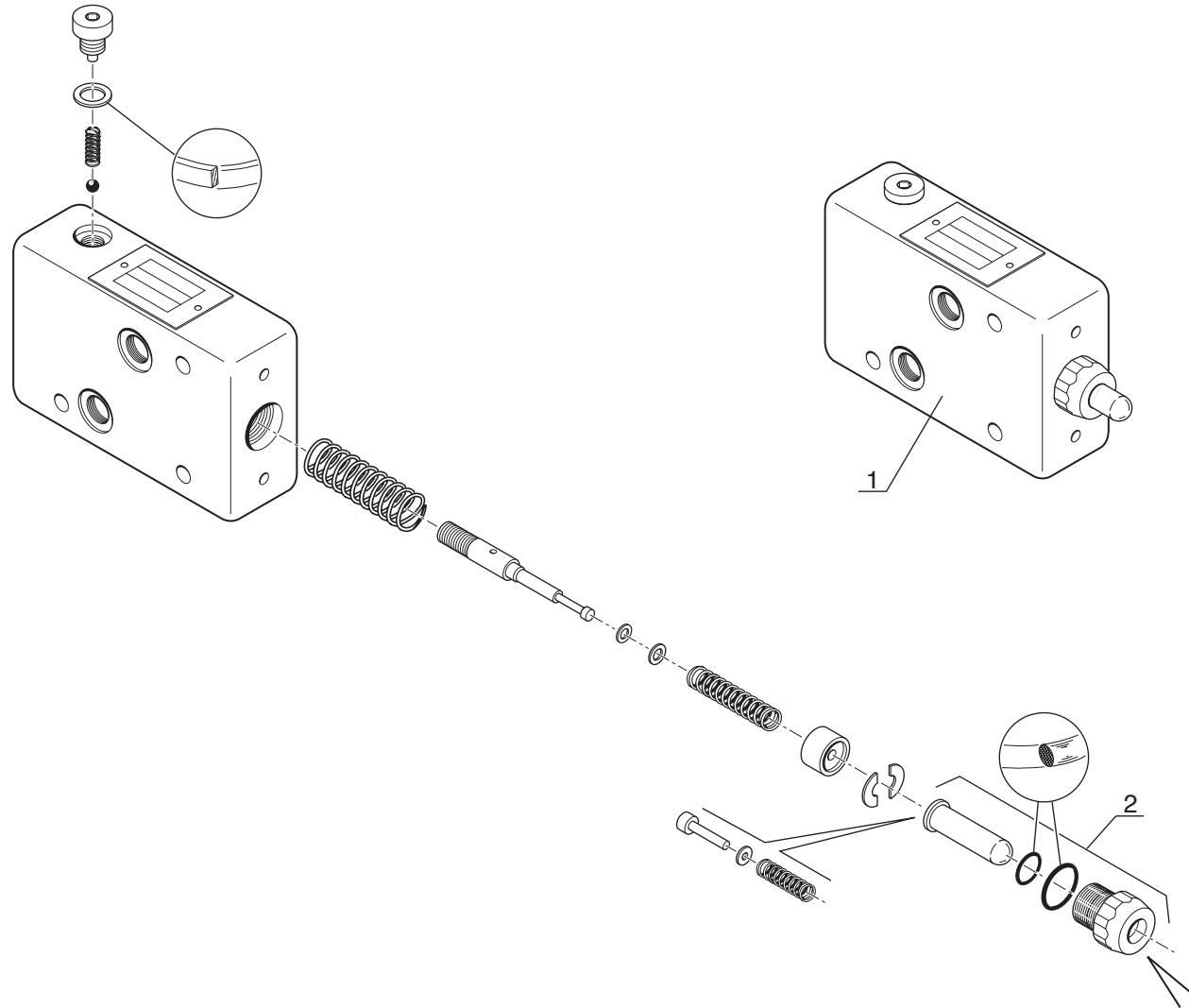

COUPLE DE SERRAGE: 3m. daN  
ANZIEHDREHMOMENTE: 3m. daN  
PAR DE APRIETE: 3m. daN  
TIGHTENING TORQUES: 3m. daN  
COPPIA DI SERRAGGIO: 3m. daN

**Catalogue : 270373MOD**

1	REDUCTEUR DE PRESSION DRUCKMINDERVENTIL REDUCTOR DE PRESION PRESSURE REDUCING VALVE RIDUTTORE DI PRESSIONE			Qté-Menge-Cant-Qty-Q.ta										BC		166		M					
	Rep Hinw Fig Item Rif	Numéro Teil-Nr Numero Part-Nr Part-Nr	Désignation Bezeichnung Descripcion Description Descrizione	1	2	3	4	5	6	7	8	9	10	11	12	13	14		15	16	17	18	19
1	270373	Réducteur de pression complet - Komplette inching ventil Valvulá de inching completa - Complete inching valve Riduttore di pressione completo	1																				
2	748345	Ensemble guide et poussoir - Fadenführer mit drücker Conjunto guiá con cebador - Pusher with its guide Kit guida e spintore -	1																				



**POMPE A CYLINDREE VARIABLE**  
**VERSTELLPUMPE**  
**BOMBA DE CILINDRADA VARIABLE**  
**VARIABLE DISPLACEMENT PUMP**  
**POMPA CILINDRATA VARIABILE**

<b>TYPE - TYPEN</b>		<b>A4VG71DA1 D7/32R</b>
<b>TIPO - TYPE</b>		
<b>TIPO</b>		

<b>REFERENCE - NUMMER</b>		<b>270 375</b>
<b>NUMERO - NUMBER</b>		
<b>RIFERIMENTO</b>		

BC 165

POMPE A CYLINDRÉE VARIABLE  
VERSTELLPUMPE  
BOMBA DE CILINDRADA VARIABLE  
VARIABLE DISPLACEMENT PUMP  
POMPA CILINDRATA VARIABLE

MH 20-4 T BUGGIE S2-E3  
MH 25-4 T BUGGIE S2-E3  
MSI 20 / 25 / 30 / 35 T S2-E3  
MSI 20 / 25 / 30 / 35 T BUGGIE S2-E3

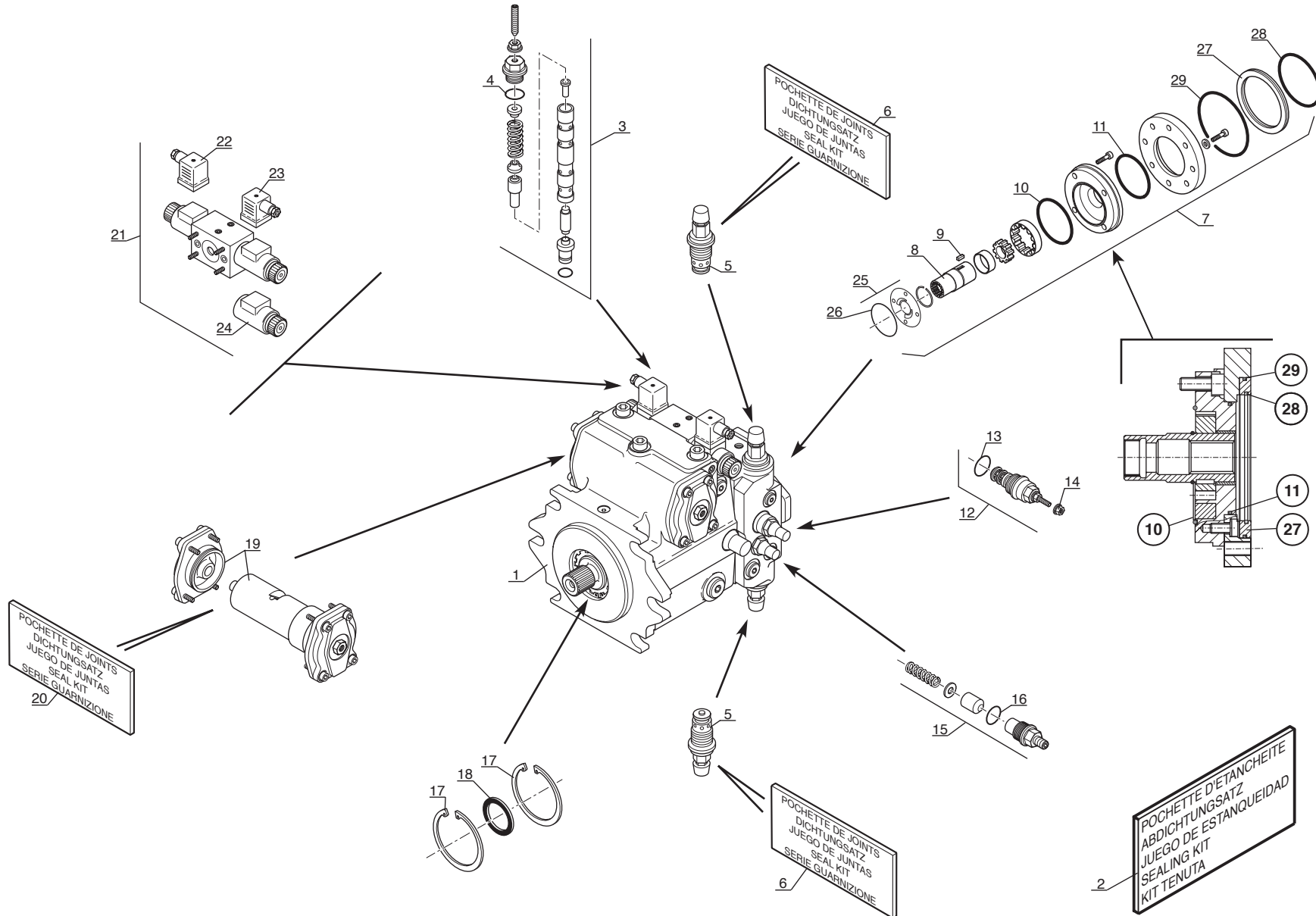



Catalogue : 270375MOD

Qté-Menge-Cant-Qty-Q.ta | BC 165 | M

1  
 POMPE A CYLINDREE VARIABLE  
 VERSTELLPUMPE  
 BOMBA DE CILINDRADA VARIABLE  
 VARIABLE DISPLACEMENT PUMP  
 POMPA CILINDRATA VARIABILE

1-	270375MOD	11-
2-		12-
3-		13-
4-		14-
5-		15-
6-		16-
7-		17-
8-		18-
9-		19-
10-		20-

Rep Hinw Fig Item Rif	Numéro Teil-Nr Numero Part-Nr Part-Nr	Désignation Bezeichnung Descripcion Description Descrizione
-----------------------------------	---	---

1	2	3	4	5	6	7	8	9	10	11	12	13	14	15	16	17	18	19	20
---	---	---	---	---	---	---	---	---	----	----	----	----	----	----	----	----	----	----	----

1	270375	Pompe hydrostatique Bomba hidrostática Pompa idrostatica	- Hydrostatik pumpe - Hydrostatic pump -
2	703019	Pochette d'étanchéité Juego de estanqueidad Kit tenuta	- Abdichtungssatz - Sealing kit -
3	199363	Valve (DR) Válvula (DR) Valvola	- Druckabschneidung - Pressure cut-off -
4	201149	Joint torique Junta tórica Anello OR	- "0" ring - "0" ring -
5	565433	Limiteur de pression Reguladores de presión Limitatore di pressione	- Druckbegrenzungventil - Relief valve -
6	565434	Pochette de joints Juego de juntas Kit guarnizióne	- Dichtungssatz - Seal kit -
7	703017	Pompe à engrenage Bomba de engranajes Pompa ingranaggio	- Zahnradpumpen - Gear pump -
8	600997	Manchon Manguito Manicotto	- Muffe - Coupling -
9	600525	Clavette Chaveta Chiavetta	- Keil - Key -
10	199333	Joint torique Junta tórica Anello OR	- "0" ring - "0" ring -
11	408887	Joint torique Junta tórica Anello OR	- "0" ring - "0" ring -

1																			
1																			
1																			
1																			
2																			
2																			
1																			
1																			
1																			
1																			

+

Catalogue : 270375MOD

2

POMPE A CYLINDREE VARIABLE  
 VERSTELLPUMPE  
 BOMBA DE CILINDRADA VARIABLE  
 VARIABLE DISPLACEMENT PUMP  
 POMPA CILINDRATA VARIABILE

Qté-Menge-Cant-Qty-Q.ta

BC

165

M

1-	270375MOD	11-
2-		12-
3-		13-
4-		14-
5-		15-
6-		16-
7-		17-
8-		18-
9-		19-
10-		20-

Rep Hinw Fig Item Rif	Numéro Teil-Nr Numero Part-Nr Part-Nr	Désignation Bezeichnung Descripcion Description Descrizione																				
			1	2	3	4	5	6	7	8	9	10	11	12	13	14	15	16	17	18	19	20
12	458502	Cartouche de régulation Cartucho de regulación Cartuccia di regolazione	-	Regelventil Control valve -	1																	
13	401831	Joint torique Junta tórica Anello OR	-	"0" ring "0" ring -	1																	
14	409248	Ecrou Tuerca Dado	-	Mutter Nut -	1																	
15	199362	Limiteur de pression Reguladores de presión Limitatore di pressione	-	Druckbegrenzventil Relief valve -	1																	
16	56903	Joint torique Junta tórica Anello OR	-	"0" ring "0" ring -	1																	
17	600518	Circlips Aro retén Anello elastico	-	Sicherungsring Circlip -	2																	
18	703014	Joint d'étanchéité Junta de estanqueidad Guarnizione di tenuta	-	Dichtungsring Seal -	1																	
19	703015	Réglage hydraulique Regulación hidraulico Regolazione idraulico	-	Hydraulischer verstellung Hydraulic control -	1																	
20	703016	Pochette de joints Juego de juntas Kit guarnizióni	-	Dichtungssatz Seal kit -	1																	
21	602063	Distributeur Distribuidor Distributore	-	Kommandosteuerventil Valve bank -	1																	
22	58112	Prise de connexion Toma de conexión Presa di connessione	-	Gerätesteckdose Connection test -	1																	

+

Catalogue : 270375MOD

3

POMPE A CYLINDREE VARIABLE  
 VERSTELLPUMPE  
 BOMBA DE CILINDRADA VARIABLE  
 VARIABLE DISPLACEMENT PUMP  
 POMPA CILINDRATA VARIABLE

Qté-Menge-Cant-Qty-Q.ta

BC

165

M

1-	270375MOD	11-
2-		12-
3-		13-
4-		14-
5-		15-
6-		16-
7-		17-
8-		18-
9-		19-
10-		20-

Rep Hinw Fig Item Rif	Numéro Teil-Nr Numero Part-Nr Part-Nr	Désignation Bezeichnung Descripcion Description Descrizione																				
			1	2	3	4	5	6	7	8	9	10	11	12	13	14	15	16	17	18	19	20
23	58113	Prise de connexion Toma de conexión Presa di connessione	-	Gerätesteckdose - Connection test -	1																	
24	602064	Solénoïde Solenoid Solenoid	-	Solenoid - Solenoid -	2																	
25	703018	Plaque d'usure Placa de desgaste Piastra du usura	-	Verschleissplatte - Friction lining side -	1																	
26	199333	Joint torique Junta tórica Anello OR	-	"0" ring - "0" ring -	1																	
27	561255	Bague Anillo Anello	-	Büchse - Bushing -	1																	
28	474783	Joint torique Junta tórica Anello OR	-	"0" ring - "0" ring -	1																	
29	600528	Joint torique Junta tórica Anello OR	-	"0" ring - "0" ring -	1																	



**MOTEUR A CYLINDREE FIXE**  
**MOTOR MIT FESTEM HUBRAUM**  
**MOTOR DE CILINDRADA FIJA**  
**MOTOR WITH FIXED CAPACITY**  
**MOTORE A CILINDRATA FISSA**

BC 98

MOTEUR A CYLINDREE FIXE  
MOTOR MIT FESTEM HUBRAUM  
MOTOR DE CILINDRADA FIJA  
MOTOR WITH FIXED CAPACITY  
MOTORE A CILINDRATA FISSA

MH 20-4 T BUGGIE S2-E3  
MH 25-4 T BUGGIE S2-E3  
MSI 20 / 25 / 30 / 35 T S2-E3  
MSI 20 / 25 / 30 / 35 T BUGGIE S2-E3

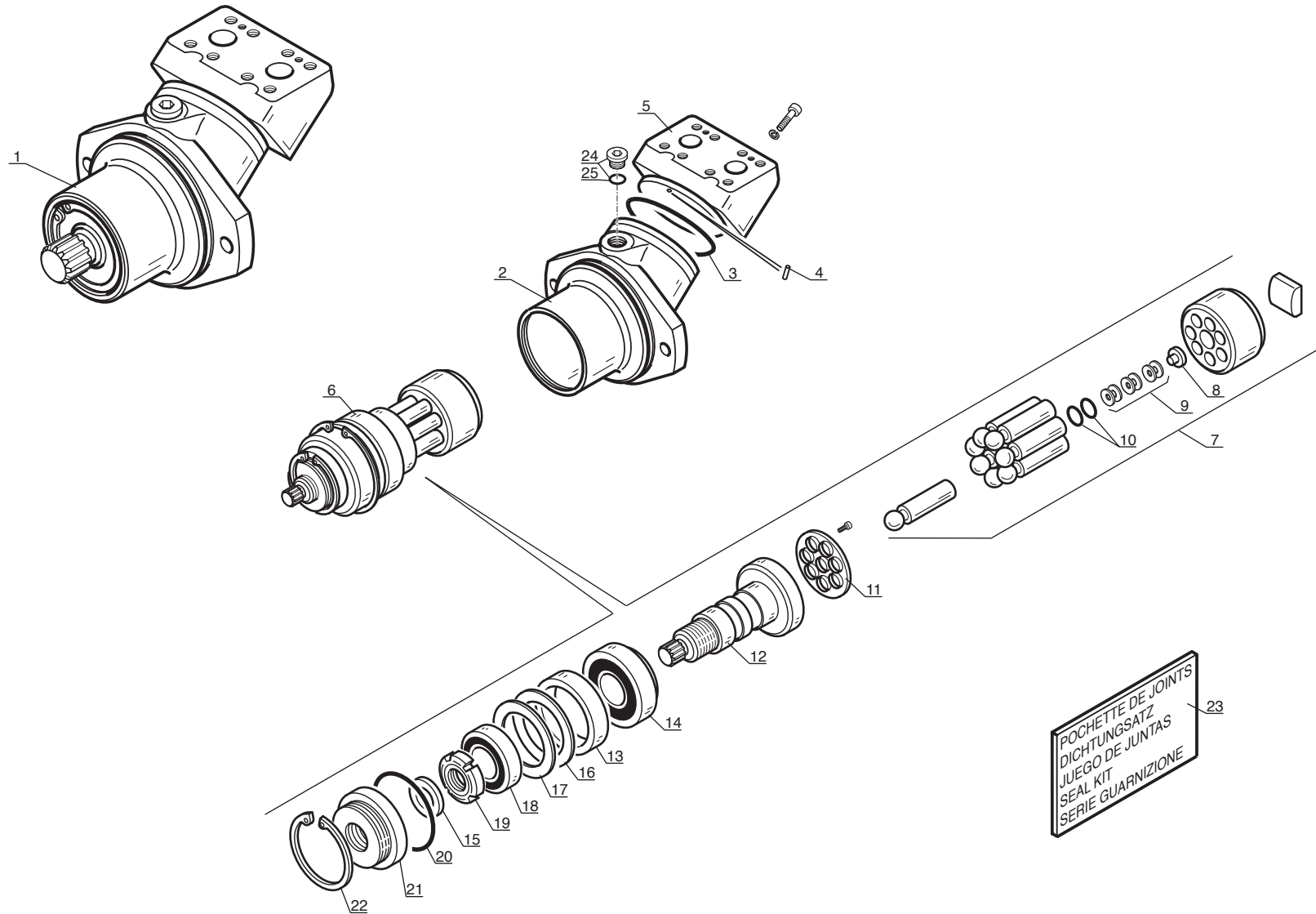

POCHETTE DE JOINTS  
DICHTUNGSATZ  
JUEGO DE JUNTAS  
SEAL KIT  
SERIE GUARNIZIONE

Catalogue : 201551MOD

Qté-Menge-Cant-Qty-Q.ta		BC	98	M																
1- 201551MOD	11-																			
2-	12-																			
3-	13-																			
4-	14-																			
5-	15-																			
6-	16-																			
7-	17-																			
8-	18-																			
9-	19-																			
10-	20-																			
1	2	3	4	5	6	7	8	9	10	11	12	13	14	15	16	17	18	19	20	
2																				
1																				
1																				
1																				
1																				
1																				
6																				
14																				
1																				

Rep Hinw Fig Item Rif	Numéro Teil-Nr Numero Part-Nr Part-Nr	Désignation Bezeichnung Descripcion Description Descrizione
1	201551	Moteur hydrostatique complet - Kompletter hydrostatik motor Motor hidrostático completo - Complete hydrostatic motor Motore idrostatico completo -
2	548755	Carter - Gehäuse Cárter - Housing Carter -
3	548758	Joint torique - "O" ring Junta tórica - "O" ring Anello OR -
4	548757	Pion de centrage - Zentrierstift Espiga de centraje - Centering pin Perno di centraggio -
5	548756	Plaque de raccordement - Anschlussplatte Placa de conexion - Connection plate Piastra di raccordo -
6	548754	Rotor hydrostatique - Triebwerk Rotor hidrostático - Rotary group Rotore idrostatico -
7	548759	Piston d'entraînement - Antriebskolben Pistón de arrastre - Driving piston Pistone di fermo -
8	548770	Coupelle - Treibofen Copela - Cup Coppela -
9	548771	Rondelle ressort - Federscheibe Arandela muelle - Spring washer Rondella molla -
10	548772	Bague - Büchse Anillo - Bushing Anello -
11	548763	Plaque de fixation - Befestigung Platte Placa de fijación - Fastening plate Piastra di fissaggio -

+

Catalogue : 201551MOD

2

MOTEUR A CYLINDREE FIXE  
 MOTOR MIT FESTEM HUBRAUM  
 MOTOR DE CILINDRADA FIJA  
 MOTOR WITH FIXED CAPACITY  
 MOTORE A CILINDRATA FISSA

Qté-Menge-Cant-Qty-Q.ta

BC

98

M

1-	201551MOD	11-
2-		12-
3-		13-
4-		14-
5-		15-
6-		16-
7-		17-
8-		18-
9-		19-
10-		20-

Rep Hinw Fig Item Rif	Numéro Teil-Nr Numero Part-Nr Part-Nr	Désignation Bezeichnung Descripcion Description Descrizione	Qté-Menge-Cant-Qty-Q.ta																			
			1	2	3	4	5	6	7	8	9	10	11	12	13	14	15	16	17	18	19	20
12	548760	Arbre Arbol Albero - Welle - Shaft -	1																			
13	548761	Bague Anillo Anello - Büchse - Bushing -	1																			
14	548765	Roulement Rodamiento Cuscinetto - Läger - Bearing -	1																			
15	548767	Joint d'étanchéité Junta de estanqueidad Guarnizione di tenuta - Dichtungsring - Seal -	1																			
16	548769	Rondelle (0,1 mm) Arandela Rondella - Unterlegscheibe - Washer -	2																			
17	403722	Rondelle (0,3 mm) Arandela Rondella - Unterlegscheibe - Washer -	1																			
18	548766	Roulement Rodamiento Cuscinetto - Läger - Bearing -	1																			
19	548764	Ecrou Tuerca Dado - Mutter - Nut -	1																			
20	548768	Joint torique Junta tórica Anello OR - "O" ring - "O" ring -	1																			
21	548762	Anneau de fermeture Anillo de cierre Anello di chiusura - Verschlussring - Front cover -	1																			
22	548691	Circlips Aro retén Anello elastico - Sicherungsring - Circlip -	1																			

+



Catalogue : 201551MOD

3

MOTEUR A CYLINDREE FIXE  
 MOTOR MIT FESTEM HUBRAUM  
 MOTOR DE CILINDRADA FIJA  
 MOTOR WITH FIXED CAPACITY  
 MOTORE A CILINDRATA FISSA

Qté-Menge-Cant-Qty-Q.ta

BC

98

M

1-	201551MOD	11-
2-		12-
3-		13-
4-		14-
5-		15-
6-		16-
7-		17-
8-		18-
9-		19-
10-		20-

Rep Hinw Fig Item Rif	Numéro Teil-Nr Numero Part-Nr Part-Nr	Désignation Bezeichnung Descripcion Description Descrizione
23	548773	Pochette d'étanchéité Juego de estanqueidad Kit tenuta - Abdichtungssatz - Sealing kit -
24	248399	Raccord bouchon Racor tapón Raccordo tappo - Stopfen verschraubung - Plug connection -
25	190016	Joint d'étanchéité Junta de estanqueidad Guarnizione - Dichtungsring - Seal -

1	2	3	4	5	6	7	8	9	10	11	12	13	14	15	16	17	18	19	20	
1																				
1																				
1																				



**MOTEUR DE ROUE**  
**RAD MOTOR**  
**MOTOR DE RUEDA**  
**WHEEL MOTOR**  
**MOTORINO DI RUOTE**

BF 23

MOTEUR DE ROUE  
RAD MOTOR  
MOTOR DE RUEDA  
WHEEL MOTOR  
MOTORINO DI RUOTA

MH 20-4 T BUGGIE S2-E3  
MH 25-4 T BUGGIE S2-E3

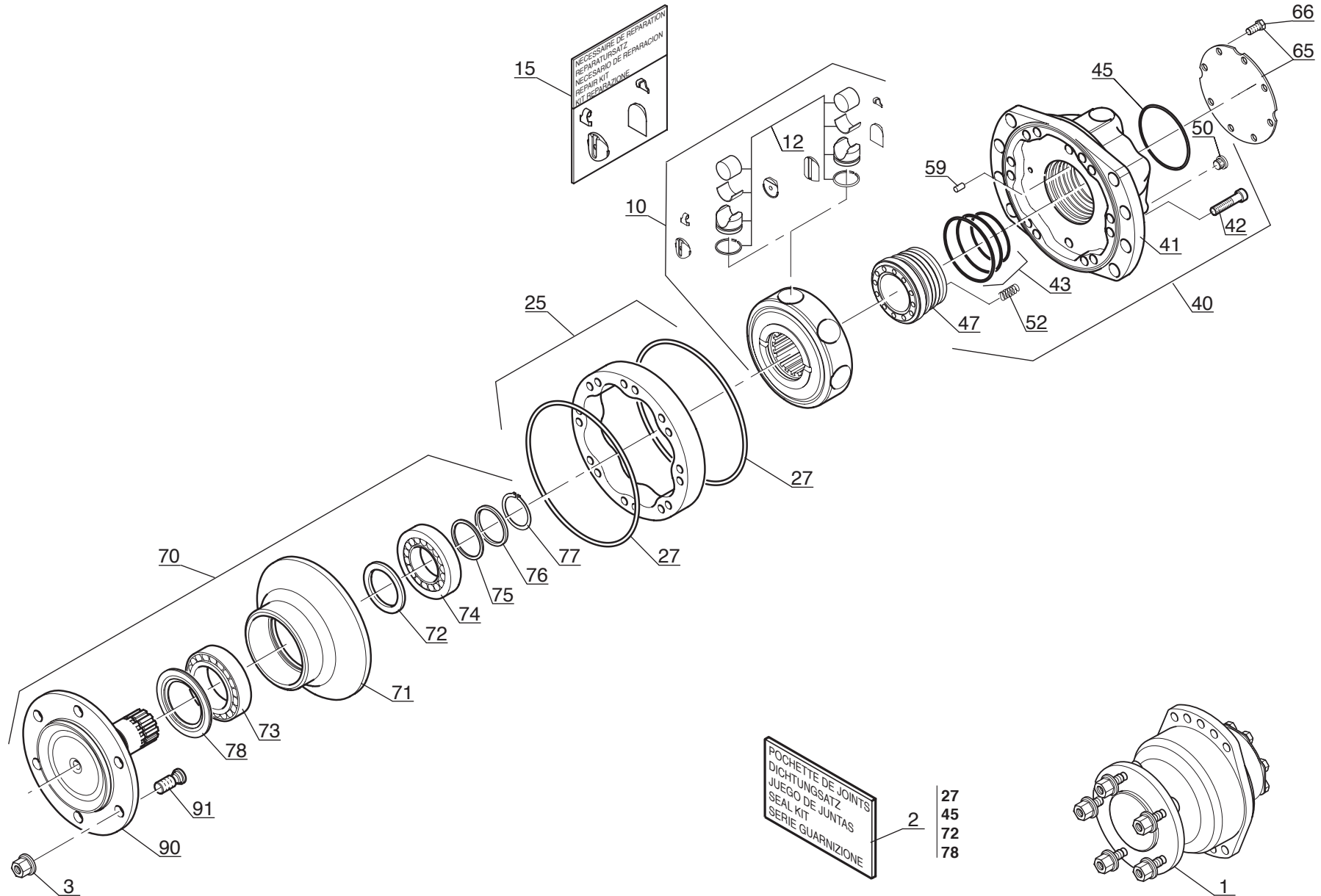

Catalogue : 249355MOD

1

MOTEUR DE ROUE  
 RAD MOTOR  
 MOTOR DE RUEDA  
 WHEEL MOTOR  
 MOTORINO DI RUOTA

Qté-Menge-Cant-Qty-Q.ta

BF

23

M

1-	249355MOD	11-
2-		12-
3-		13-
4-		14-
5-		15-
6-		16-
7-		17-
8-		18-
9-		19-
10-		20-

Rep Hinw Fig Item Rif	Numéro Teil-Nr Numero Part-Nr Part-Nr	Désignation Bezeichnung Descripcion Description Descrizione	1	2	3	4	5	6	7	8	9	10	11	12	13	14	15	16	17	18	19	20	
1	249355	Moteur de roue Motor de rueda Motorino di ruota - Rad motor - Wheels motor -	2																				
2	562146	Pochette de joints Juego de juntas Serie guarnizióne - Dichtungssatz - Seal kit -	1																				
3	603708	Jeu d'écrou de roue Juego de tuerca de rueda Kit dado ruote - Rad mutter satz - Wheel nut kit -	1																				
10	550882	Bloc cylindres Bloque de cilindros Monoblocco cilindro - Zylinderblock - Cylinder block -	1																				
12	703043	Piston (Cylindre 0) Pistón (Cilindro 0) Pistone (Cilindri 0) - Kolben (Zylinder 0) - Piston (Cylinder 0) -	X																				
15	550885	Nécessaire de réparation Necesario de reparaci3n Kit riparazione - Reparatursatz - Repair kit -	1																				
25	550886	Came complète Leva completa Camma completa - Kompletter Nocke - Complete cam -	1																				
27	550887	Joint torique Junta t3rica Anello OR - "0" ring - "0" ring -	2																				
40	603703	Carter complet Cárter completo Carter completo - Kompletter Gehäuse - Complete housing -	1																				
41	603704	Carter Cárter Carter - Gehäuse - Housing -	1																				
42	562145	Vis Tornillo Vite - Schraube - Screw -	6																				

+

Catalogue : 249355MOD

2

MOTEUR DE ROUE  
 RAD MOTOR  
 MOTOR DE RUEDA  
 WHEEL MOTOR  
 MOTORINO DI RUOTA

Qté-Menge-Cant-Qty-Q.ta

BF

23

M

1-	249355MOD	11-
2-		12-
3-		13-
4-		14-
5-		15-
6-		16-
7-		17-
8-		18-
9-		19-
10-		20-

Rep Hinw Fig Item Rif	Numéro Teil-Nr Numero Part-Nr Part-Nr	Désignation Bezeichnung Descripcion Description Descrizione	Qté-Menge-Cant-Qty-Q.ta																			
			1	2	3	4	5	6	7	8	9	10	11	12	13	14	15	16	17	18	19	20
45	550891	Joint torique Junta tórica Anello OR - "0" ring - "0" ring -	1																			
47	550892	Glace de distribution Placa de distribución Vetro - Steuerlinse - Control -	1																			
48	550893	Pochette de joints Juego de juntas Kit guarnizióne - Dichtungssatz - Seal kit -	1																			
50	550894	Bouchon Tapón Tappo - Stopfen - Plug -	1																			
52	550895	Ressort Muelle Molla - Feder - Spring -	4																			
59	550896	Goupille Pasador Spina - Stift - Pin -	1																			
65	550925	Plaque de fermeture Placa de cierre Piastra di chiusura - Schlussplatte - Fastening plate -	1																			
66	550926	Vis Tornillo Vite - Schraube - Screw -	8																			
70	603705	Palier complet Cojinete completo Cuscinetti completo - Kompletter lager - Complete bearing -	1																			
71	550898	Support palier Soporte cojinete Supporto cuscinetti - Lagerträger - Bearing bracket -	1																			
72	550899	Joint d'étanchéité Junta de estanqueidad Guarnizióne - Dichtungsring - Seal -	1																			

+

Catalogue : 249355MOD

3

MOTEUR DE ROUE  
 RAD MOTOR  
 MOTOR DE RUEDA  
 WHEEL MOTOR  
 MOTORINO DI RUOTA

Qté-Menge-Cant-Qty-Q.ta

BF

23

M

1-	249355MOD	11-
2-		12-
3-		13-
4-		14-
5-		15-
6-		16-
7-		17-
8-		18-
9-		19-
10-		20-

Rep Hinw Fig Item Rif	Numéro Teil-Nr Numero Part-Nr Part-Nr	Désignation Bezeichnung Descripcion Description Descrizione	Qté-Menge-Cant-Qty-Q.ta																			
			1	2	3	4	5	6	7	8	9	10	11	12	13	14	15	16	17	18	19	20
73	550900	Roulement Rodamiento Cuscinetto - Lager - Bearing -	1																			
74	550901	Roulement Rodamiento Cuscinetto - Lager - Bearing -	1																			
75	550902	Cale d'épaisseur Cala de espesor Spessore - Ausgleichscheibe - Shim -	1																			
76	550903	Bague Anillo Anello - Büchse - Bushing -	1																			
77	550904	Circlips Aro retén Anello elastico - Sicherungsring - Circlip -	1																			
78	550905	Bague Anillo Anello - Büchse - Bushing -	1																			
90	603706	Arbre Arbol Albero - Welle - Shaft -	1																			
91	603707	Jeu de goujon Juego de espárago de rueda Kit prigioniero - Stiftschraubensatz - Wheel stud kit -	1																			





**REDUCTEUR DE ROUE**  
**RAD REDUKTION**  
**REDUCTOR DE RUEDA**  
**WHEEL REDUCING**  
**REDUTTORE DELLE RUOTE**

**BB12**

POUR REDUCTEUR DE ROUE  
FÜR RAD REDUKTION  
PARA REDUCTOR DE RUEDA  
FOR WHEEL REDUCING  
PER RIDUTTORE DELLE RUOTE

□ Type : **CWD 2050 / 1M**

REDUCTEUR DE ROUE  
RAD REDUKTION  
REDUCTOR DE RUEDA  
WHEEL REDUCING  
RIDUTTORE DELLE RUOTE

**MSI 20 / 25 / 30 / 35 T S2-E3**  
**MSI 20 / 25 / 30 / 35 T BUGGIE S2-E3**

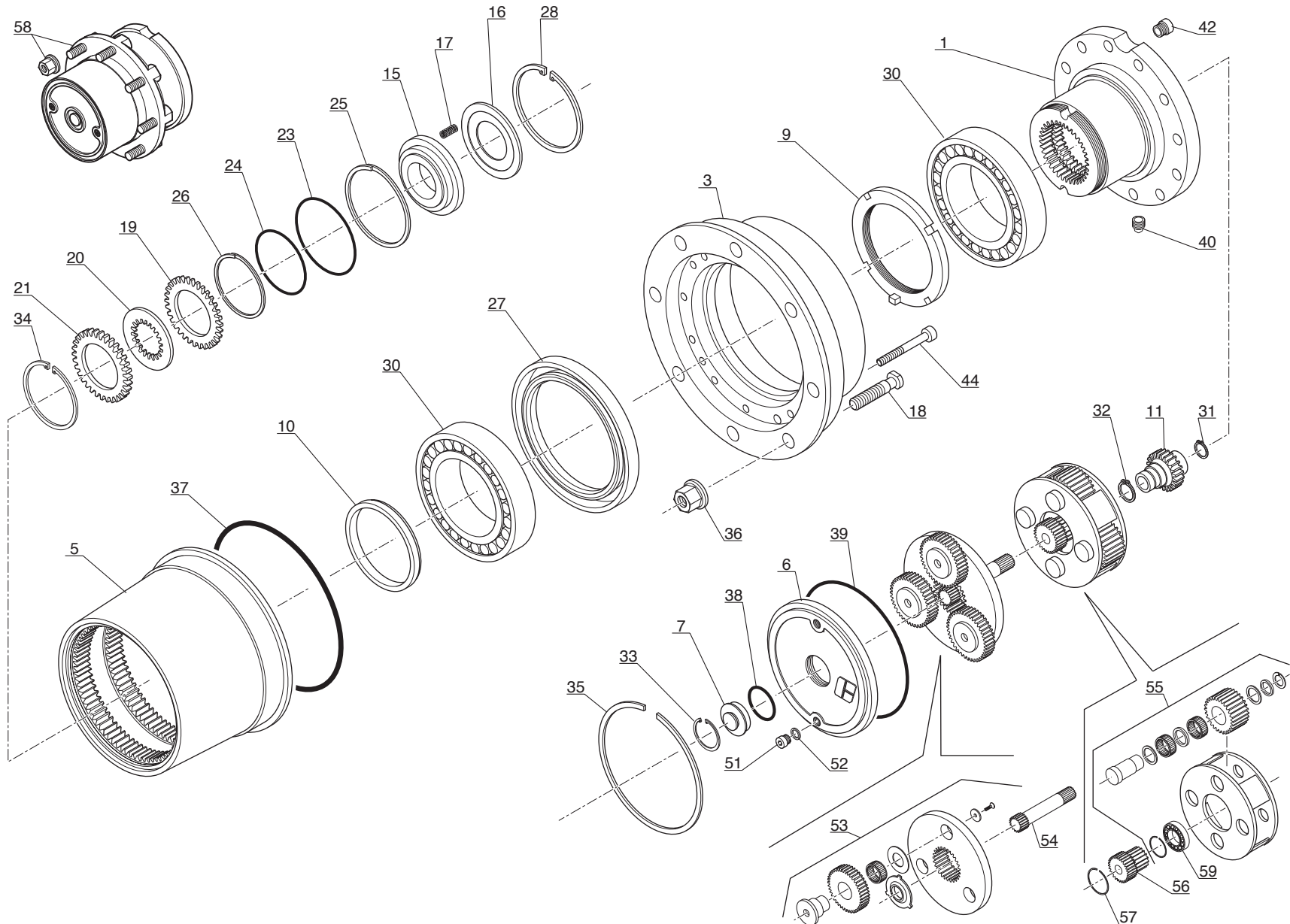

P.A.O. illus

Catalogue : 229880MOD

				Qté-Menge-Cant-Qty-Q.ta										BB		12		M					
1	REDUCTEUR DE ROUE RAD REDUKTION REDUCTOR DE RUEDA WHEEL REDUCING RIDUTTORE DI RUOTA													11-	12-	13-	14-	15-	16-	17-	18-	19-	20-
Rep Hinw Fig Item Rif	Numéro Teil-Nr Numero Part-Nr Part-Nr	Désignation Bezeichnung Descripcion Description Descrizione		1	2	3	4	5	6	7	8	9	10	11	12	13	14	15	16	17	18	19	20
1	601907	Fusée Husillo Fusello	- Achszapfen - Spindle -	1																			
3	601908	Moyeu de roue Cubo de rueda Mozzo ruota	- Radnabe - Wheel hub -	1																			
5	601909	Couronne dentée Corona dentada Corona dentata	- Zahnkranz - Gear ring -	1																			
6	561050	Couvercle Tapadera Coperchio	- Deckel - Cover -	1																			
7	561051	Butée Tope Battuta	- Anschlag - Stop -	1																			
9	601911	Ecrou Tuerca Dado	- Mutter - Nut -	1																			
10	601912	Entretoise Separador Distanziale	- Querstrebe - Spacer -	1																			
11	561053	Manchon Manguito Manicotto	- Muffe - Coupling -	1																			
15	561054	Piston Pistón Pistone	- Kolben - Piston -	1																			
16	561055	Rondelle Arandela Rondella	- Unterlegscheibe - Washer -	1																			
17	508328	Ressort Muelle Molla	- Feder - Spring -	12																			

+



Catalogue : 229880MOD

3

REDUCTEUR DE ROUE  
RAD REDUKTION  
REDUCTOR DE RUEDA  
WHEEL REDUCING  
RIDUTTORE DI RUOTA

Qté-Menge-Cant-Qty-Q.ta

BB

12

M

1-	229880MOD	11-
2-		12-
3-		13-
4-		14-
5-		15-
6-		16-
7-		17-
8-		18-
9-		19-
10-		20-

Rep Hinw Fig Item Rif	Numéro Teil-Nr Numero Part-Nr Part-Nr	Désignation Bezeichnung Descripcion Description Descrizione																				
			1	2	3	4	5	6	7	8	9	10	11	12	13	14	15	16	17	18	19	20
31	561064	Circlips Aro retén Anello elastico - Sicherungsring - Circlip -	1																			
32	561065	Circlips Aro retén Anello elastico - Sicherungsring - Circlip -	1																			
33	561066	Circlips Aro retén Anello elastico - Sicherungsring - Circlip -	1																			
34	561067	Circlips Aro retén Anello elastico - Sicherungsring - Circlip -	1																			
35	561068	Jonc d'arrêt Anillo de parada Giunto - Sprengring - Snap ring -	1																			
36	552751	Ecrou de roue Tuerca de rueda Dado ruote - Radmutter - Wheel nut -	8																			
37	561069	Joint torique Junta tórica Anello OR - "0" ring - "0" ring -	1																			
38	561070	Joint torique Junta tórica Anello OR - "0" ring - "0" ring -	1																			
39	561071	Joint torique Junta tórica Anello OR - "0" ring - "0" ring -	1																			
40	561072	Bouchon Tapón Tappo - Stopfen - Plug -	2																			
42	561073	Bouchon Tapón Tappo - Stopfen - Plug -	1																			

+

Catalogue : 229880MOD

4

REDUCTEUR DE ROUE  
 RAD REDUKTION  
 REDUCTOR DE RUEDA  
 WHEEL REDUCING  
 RIDUTTORE DI RUOTA

Qté-Menge-Cant-Qty-Q.ta

BB

12

M

1- 229880MOD 11-  
 2- 12-  
 3- 13-  
 4- 14-  
 5- 15-  
 6- 16-  
 7- 17-  
 8- 18-  
 9- 19-  
 10- 20-

Rep Hinw Fig Item Rif	Numéro Teil-Nr Numero Part-Nr Part-Nr	Désignation Bezeichnung Descripcion Description Descrizione																				
			1	2	3	4	5	6	7	8	9	10	11	12	13	14	15	16	17	18	19	20
44	561074	Vis Tornillo Vite - Schraube - Screw -	15																			
51	561076	Bouchon Tapón Tappo - Stopfen - Plug -	2																			
52	561077	Rondelle Arandela Rondella - Unterlegscheibe - Washer -	2																			
53	561080	Support satellites Soporte satélite Supporto satelliti - Planetenrad träger - Planet wheel bracket -	1																			
54	561081	Pignon Piñón Ingranaggio - Zahnrad - Gear -	1																			
55	561082	Support satellites Soporte satélite Supporto satelliti - Planetenrad träger - Planet wheel bracket -	1																			
56	561083	Pignon Piñón Ingranaggio - Zahnrad - Gear -	1																			
57	561084	Jonc d'arrêt Anillo de parada Giunto - Sprengring - Snap ring -	1																			
58	229880	Réducteur de roue Reductor de rueda Riduttore di ruota - Rad reduktion - Wheel reducing -	2																			
59	746712	Roulement Rodamiento Cuscinetto - Lager - Bearing -	1																			



**BB13**

POUR REDUCTEUR DE ROUE  
FÜR RAD REDUKTION  
PARA REDUCTOR DE RUEDA  
FOR WHEEL REDUCING  
PER RIDUTTORE DELLE RUOTE

□ Type : CWD 2050 1M / CF

REDUCTEUR DE ROUE  
RAD REDUKTION  
REDUCTOR DE RUEDA  
WHEEL REDUCING  
RIDUTTORE DELLE RUOTE

MH 20-4 T BUGGIE S2-E3  
MH 25-4 T BUGGIE S2-E3

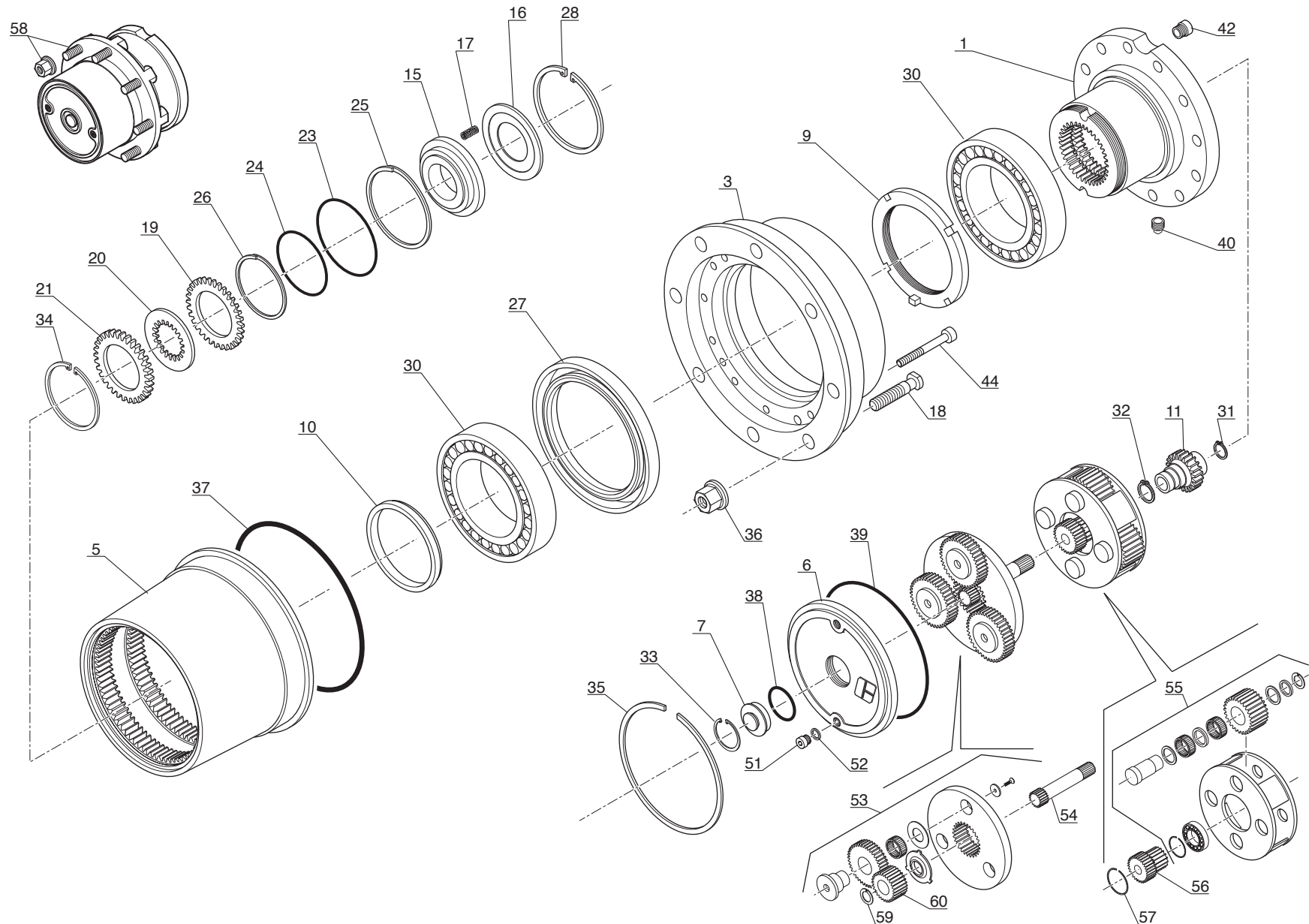



Catalogue : 236474MOD

Qté-Menge-Cant-Qty-Q.ta

BB

13

M

1

REDUCTEUR DE ROUE  
RAD REDUKTION  
REDUCTOR DE RUEDA  
WHEEL REDUCING  
RIDUTTORE DI RUOTA

1- 236474MOD 11-  
2- 12-  
3- 13-  
4- 14-  
5- 15-  
6- 16-  
7- 17-  
8- 18-  
9- 19-  
10- 20-

Rep Hinw Fig Item Rif	Numéro Teil-Nr Numero Part-Nr Part-Nr	Désignation Bezeichnung Descripcion Description Descrizione	Qté-Menge-Cant-Qty-Q.ta																			
			1	2	3	4	5	6	7	8	9	10	11	12	13	14	15	16	17	18	19	20
1	601907	Fusée Husillo Fusello - Achszapfen - Spindle -	1																			
3	601908	Moyeu de roue Cubo de rueda Mozzo ruota - Radnabe - Wheel hub -	1																			
5	601909	Couronne dentée Corona dentada Corona dentata - Zahnkranz - Gear ring -	1																			
6	561050	Couvercle Tapadera Coperchio - Deckel - Cover -	1																			
7	601910	Butée Tope Battuta - Anschlag - Stop -	1																			
9	601911	Ecrou Tuerca Dado - Mutter - Nut -	1																			
10	601912	Entretoise Separador Distanziale - Querstrebe - Spacer -	1																			
11	603971	Manchon Manguito Manicotto - Muffe - Coupling -	1																			
15	561054	Piston Pistón Pistone - Kolben - Piston -	1																			
16	561055	Rondelle Arandela Rondella - Unterlegscheibe - Washer -	1																			
17	508328	Ressort Muelle Molla - Feder - Spring -	12																			

+



Catalogue : 236474MOD

3

REDUCTEUR DE ROUE  
 RAD REDUKTION  
 REDUCTOR DE RUEDA  
 WHEEL REDUCING  
 RIDUTTORE DI RUOTA

Qté-Menge-Cant-Qty-Q.ta

BB

13

M

1-	236474MOD	11-
2-		12-
3-		13-
4-		14-
5-		15-
6-		16-
7-		17-
8-		18-
9-		19-
10-		20-

Rep Hinw Fig Item Rif	Numéro Teil-Nr Numero Part-Nr Part-Nr	Désignation Bezeichnung Descripcion Description Descrizione	Qté-Menge-Cant-Qty-Q.ta																			
			1	2	3	4	5	6	7	8	9	10	11	12	13	14	15	16	17	18	19	20
31	561064	Circlips Aro retén Anello elastico - Sicherungsring - Circlip -	1																			
32	561065	Circlips Aro retén Anello elastico - Sicherungsring - Circlip -	1																			
33	561066	Circlips Aro retén Anello elastico - Sicherungsring - Circlip -	1																			
34	561067	Circlips Aro retén Anello elastico - Sicherungsring - Circlip -	1																			
35	561068	Jonc d'arrêt Anillo de parada Giunto - Sprengring - Snap ring -	1																			
36	552751	Ecrou de roue Tuerca de rueda Dado ruote - Radmutter - Wheel nut -	8																			
37	561069	Joint torique Junta tórica Anello OR - "0" ring - "0" ring -	1																			
38	561070	Joint torique Junta tórica Anello OR - "0" ring - "0" ring -	1																			
39	561071	Joint torique Junta tórica Anello OR - "0" ring - "0" ring -	1																			
40	561072	Bouchon Tapón Tappo - Stopfen - Plug -	2																			
42	561073	Bouchon Tapón Tappo - Stopfen - Plug -	1																			

+

Catalogue : 236474MOD

4

REDUCTEUR DE ROUE  
RAD REDUKTION  
REDUCTOR DE RUEDA  
WHEEL REDUCING  
RIDUTTORE DI RUOTA

Qté-Menge-Cant-Qty-Q.ta

BB

13

M

1-	236474MOD	11-
2-		12-
3-		13-
4-		14-
5-		15-
6-		16-
7-		17-
8-		18-
9-		19-
10-		20-

Rep Hinw Fig Item Rif	Numéro Teil-Nr Numero Part-Nr Part-Nr	Désignation Bezeichnung Descripcion Description Descrizione	Qté-Menge-Cant-Qty-Q.ta																			
			1	2	3	4	5	6	7	8	9	10	11	12	13	14	15	16	17	18	19	20
44	603970	Vis Tornillo Vite - Schraube - Screw -	15																			
51	561076	Bouchon Tapón Tappo - Stopfen - Plug -	2																			
52	603972	Rondelle Arandela Rondella - Unterlegscheibe - Washer -	2																			
53	604286	Support satellites Soporte satélite Supporto satelliti - Planetenrad träger - Planet wheel bracket -	1																			
54	604288	Arbre Arbol Albero - Welle - Shaft -	1																			
55	603969	Support satellites Soporte satélite Supporto satelliti - Planetenrad träger - Planet wheel bracket -	1																			
56	561083	Pignon Piñón Ingranaggio - Zahnrad - Gear -	1																			
57	561084	Jonc d'arrêt Anillo de parada Giunto - Sprengring - Snap ring -	1																			
58	236474	Réducteur de roue Reductor de rueda Riduttore di ruota - Rad reduktion - Wheel reducing -	2																			
59	561065	Circlips Aro retén Anello elastico - Sicherungsring - Circlip -	1																			
60	604287	Pignon Piñón Ingranaggio - Zahnrad - Gear -	1																			

REVISIONS					
ZONE	ECN	REV	DESCRIPTION	DATE	APPROVED
	10642	REL	ORIGINAL RELEASE	06/27/02	R.R.K.
	10663	A	ADDED B6109	07/19/02	R.R.K.
2C	10936	B	CHANGE PN ITEM 6	03/11/03	R.R.K.
ALL	11765	C	ADD LASHING RING, EYELET, & DECAL	03/28/05	R.R.K.
	12179	D	ADDED 164091	11/13/06	MLA

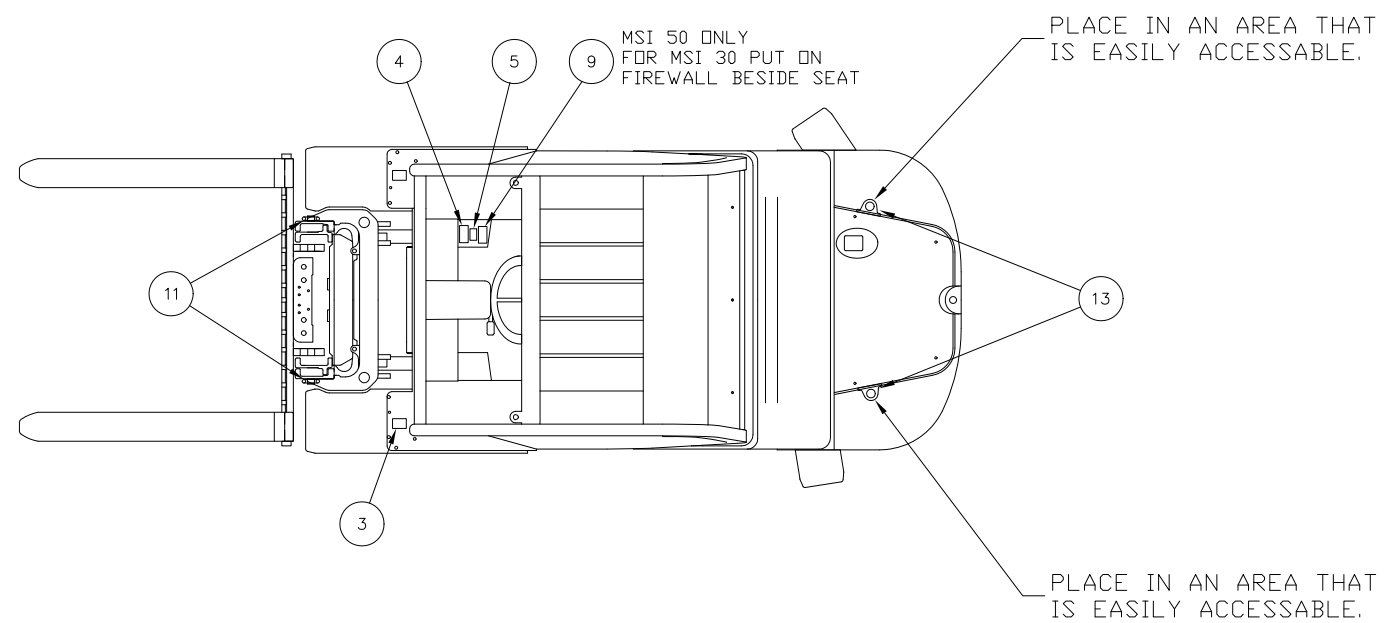
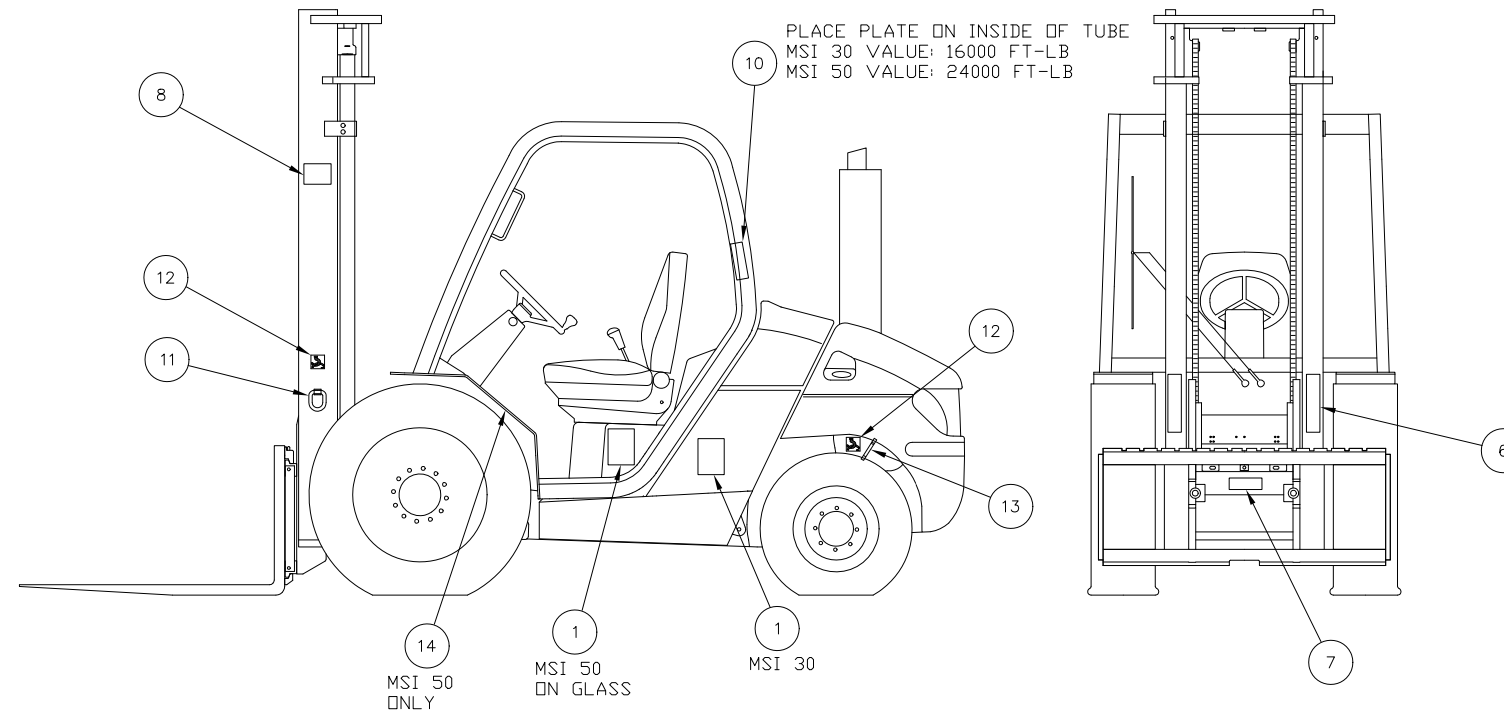
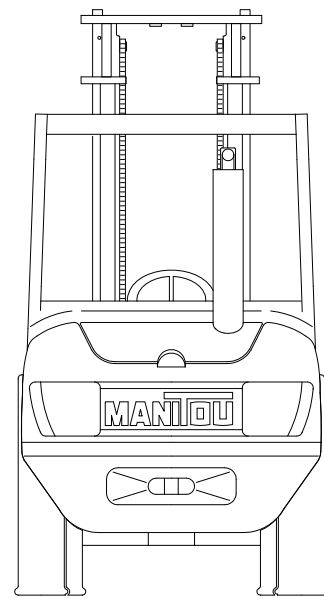

14	164091	164091	DECAL, BRAKE FLUID	1
13	574130	574130	TIE DOWN, EYELET	2
12	24653	N/D	DECAL, TIE-DOWN POINT	4
11	424959	424959	RING, LASHING	2
10	B6109	B6109	OHG CAPICITY PLATE	1
9	496538	496538	PLATE, VERT MASTED TRUCK	1
8	R2016	R2016	PLATE, NAME	1
7	426643	426643	DECAL, LARGE PINCH POINT	2
6	426641	426641	DECAL, FORK WARNING	2
5	494918	494918	DECAL, PUSH/TOW WARNING	1
4	M0000207	M0000207	DECAL, CAUTION	1
3	496735	496735	DECAL, NO STEP	2
2	496734	496734	DECAL, MAST & FORK CONT.	1
1	420732	420732	DECAL, NO RIDERS	2
ITEM	KDM NO	DWG NO	DESCRIPTION	QTY

DO NOT SCALE DRAWING DEBUR AND REMOVE ALL SHARP EDGES

**K-D MANITOU**  
WACO, TEXAS

**DECAL GP**

NEXT ASSY	QTY	UNIT	QTY
APPLICATION			

TOLERANCES (EXCEPT AS NOTED)		MATERIAL CODE	
.XX	FRACTION 1/32	DRAWN	DATE 06/27/02
.02		MLA	
.XXX	ANGLE 1°	CHECKED	DATE 06/27/02
.01		RRK	
.XXXX	SURFACE 125	APPROVED	DATE 06/27/02
.005		RRK	

SIZE: D WEIGHT: DWG NO: 802416

SCALE: NONE SOURCE: MANUF SHEET: 397

