



MANITOU AMERICAS, INC.
One Gehl Way
P.O. Box 179
West Bend, WI 53095-0179 U.S.A.

REF : CD 647483

M 26-2/4 + H ST3B

M 30-2/4 + H ST3B

M 40-2/4 + H ST3B

M 50-2/4 + H ST3B

4 Speed and Hydrostatic Transmission

CATALOGUE PIECES
ERSATZTEILKATALOG
CATALOGO DE PIEZAS
PARTS CATALOGUE
CATALOGO RICAMBI

1ère DATE D'ÉDITION - 1st DATUM AUSGABE
1ra FECHA EDICION - 1st DATE PUBLICATION
1a DATA DI PUBBLICAZIONE

06 / 2014

INFORMATION CATALOGUE KATALOG AUSKUNFT INFORMACION CATALOGO CATALOGUE INFORMATION INFORMAZIONI CATALOGO	DATE D'ÉDITION DATUM AUSGABE FECHA EDICION DATE PUBLICATION DATA DI PUBBLICAZIONE	OBSERVATION BEMERKUNG OBSERVACION OBSERVATION OSSERVAZIONI
IC 737	06 / 2014	1ère EDITION - 1st AUSGABE 1ra EDICION - 1st PUBLICATION 1a EDIZIONE

IMPORTANT

NOMENCLATURES :

Les pages de texte portent en haut à gauche, un chiffre, ex : 1 et en bas un signe +.

- Le «1» signifie qu'il s'agit de la première page de texte.
- Le «+» indique que la nomenclature n'est pas terminée et qu'il existe d'autres pages à suivre, la dernière page ne comporte pas ce signe +.
- Le signe «X» dans les colonnes Qté = Suivant besoin.

COMMANDES DE PIECES :

Pour passer vos commandes, préciser toujours :

- N° de pièce rechange
- Désignation complète
- Quantité
- Type de machine
- N° dans la série de la machine
- N° d'identification du composant (mât, flèche, cabine, moteur, etc.)

ATTENTION :

Certaines pièces ou montages de pièces illustrés dans ce catalogue sont livrés seulement en option et non avec la machine standard.

SYMBOLISATION :

- └─▶ : A partir de (machine, moteur, date, etc.)
─▶┘ : Jusqu'à (machine, moteur, date, etc.)

- □ : Pour (machine, moteur, etc.)
□ □ : Sauf pour (machine, moteur, etc.)
◀ : Voir planche

- , ■, ▲, ★, ⊕, ⊗, ⊙, ⊚ : Jusqu'à } machine N°,
○, □, △, ☆, ⊗, ⊙, ⊚ : A partir } N° moteur, cabine,
transmission, etc.

WICHTIG

NOMENKLATUR :

Die Textseiten tragen links oben eine Zahl, zum Beispiel : 1 und unten das Zeichen +.

- die Zahl «1» bedeutet, daß es sich um die erste Textseite handelt.
- das Zeichen «+» gibt an, daß die Teileliste nicht abgeschlossen ist und daß noch weitere Seiten folgen werden, auf der letzten Seite ist kein + Zeichen vorgesehen.
- das Zeichen «X» in den Spalten Menge = je nach Bedarf.

BESTELLUNG VON TEILEN :

Bei Ihrer Bestellung bitte immer folgende Daten angeben :

- Nr. des Ersatzteiles
- komplette Bezeichnung
- Menge
- Typ der Maschine
- Seriennummer der Maschine
- Identifikationsnummer des Bestandteiles (Mast, Ausleger, Kabine, Motor, usw.)

ACHTUNG :

Bestimmte in diesem Katalog illustrierte Teile oder Montagen von Teilen werden ausschließlich als Option geliefert und nicht mit der Maschine in ihrer Standardausführung.

SYMBOLISIERUNG :

- └─▶ : Ab (Maschine, Motor, Datum, usw.)
─▶┘ : Bis (Maschine, Motor, Datum, usw.)

- □ : Bei (Maschine, Motor, Datum, usw.)
□ □ : Außer bei (Maschine, Motor, Datum, usw.)
◀ : siehe Tafel

- , ■, ▲, ★, ⊕, ⊗, ⊙, ⊚ : Bis } Maschine N°,
○, □, △, ☆, ⊗, ⊙, ⊚ : Ab } Motor Nr, kabine,
Transmission, usw.

IMPORTANTE

NOMENCLATURAS :

Las páginas de texto llevan una cifra en la parte superior izquierda, por ejemplo : 1, y un signo + en la parte inferior.

- El «1» significa que se trata de la primera página de texto.
- El «+» indica que la nomenclatura no está terminada y que seguirán otras páginas. La última página no lleva este signo +.
- El signo «X» en las columnas Cant. = Según las necesidades.

PEDIDOS DE PIEZAS :

Cuando efectúe sus pedidos, indique siempre :

- N° de pieza de recambio
- Designación completa
- Cantidad
- Tipo de máquina
- N° en la serie de la máquina
- N° de identificación del componente (mástil, pluma, cabina, motor, etc.)

ATENCIÓN :

Ciertas piezas o montajes de piezas ilustrados en este catálogo se suministran únicamente como opción y no con la máquina estándar.

SÍMBOLOS :

- └─▶ : A partir de (máquina, motor, fecha, etc.)
─▶┘ : Hasta (máquina, motor, fecha, etc.)

- □ : Para (máquina, motor, etc.)
□ □ : Salvo para (máquina, motor, etc.)
◀ : Ver la lámina

- , ■, ▲, ★, ⊕, ⊗, ⊙, ⊚ : Hasta } máquina N°,
○, □, △, ☆, ⊗, ⊙, ⊚ : A partir } N° motor, cabina,
transmisión, etc.

IMPORTANT

PARTS LISTS :

The text pages have a figure (for example : 1) printed in the top left corner, and a sign at the bottom (+).

- «1» means that this is the first page of text.
- «+» means that the parts list is not finished, and that there are more pages. The last page does not have the «+» sign.
- «X» in the Quantity columns means = according to need.

PARTS ORDER :

When placing an order, always state :

- Spare part ref. number
- Complete description
- Quantity
- Type of machine
- Machine serial number.
- Component identification number
(mast, jib, cab, engine, etc)

CAUTION :

Certain parts, or part assemblies illustrated in this catalogue are only supplied as options, and not with the standard machine.

SYMBOLS :

┌─▶ : From (machine, engine, date, etc.)
─▶┐ : Up to (machine, engine, date, etc.)

□ □ : For (machine, engine, date, etc.)
□ □ : Except for (machine, engine, date, etc.)
◁ : See drawing

●, ■, ▲, ★, ⊕, ⊗, ⊙, ⊚ : Up to } machine N°,
○, □, △, ☆, ⊗, ⊙, ⊚ : From } N° engine, cab,
transmission, etc.

IMPORTANTE

NOMENCLATURA :

Le pagine di testo hanno in alto a sinistra, una cifra, esempio : 1 e in basso un segno +.

- L' «1» significa che si tratta della prima pagina di testo.
- Il «+» indica che la nomenclatura non è terminata e che esistono altre pagine a seguire, l'ultima pagina è senza il segno +.
- Il segno «X» nelle colonne Qtà = secondo il bisogno.

ORDINE DI PEZZI :

Per passare i vostri ordini, precisare sempre :

- N° pezzo di ricambio
- Descrizione completa
- Quantità
- Tipo di macchina
- N° di serie della macchina
- N° d'identificazione componente
(rampa, braccio, cabina, motore, ecc.)

ATTENZIONE :

Alcuni pezzi o montaggio di pezzi illustrati in questo catalogo vengono spediti solamente come optional e non con la macchina standard.

SIMBOLI :

┌─▶ : A partire da (macchina, motore, data, ecc.)
─▶┐ : Fino a (macchina, motore, data, ecc.)

□ □ : Per (macchina, motore, ecc.)
□ □ : Escluso per (macchina, motore, ecc.)
◁ : Vedere tavola

●, ■, ▲, ★, ⊕, ⊗, ⊙, ⊚ : Fino a } macchina N°,
○, □, △, ☆, ⊗, ⊙, ⊚ : A partire da } N° motore, cabina,
trasmissione, ecc.

PIECES D'ORIGINE
ORIGINAL ERSATZTEILEN
PIEZAS LEGITIMAS
GENUINE PARTS
RICAMBI ORIGINALI



SPARE PARTS



Manitou Americas Parts Department:

TEL : 262-338-6653

FAX : 1-800-252-6684

Email: americasparts@manitou-group.com

6 BA 122

B

FREIN A MAIN
HANDBREIWE
FRENO DE MANO
HANDBRAKE
FRENO A MANO

D

M 30-2 ST3B
M 30-4 ST3B
M 50-2 ST3B
M 50-4 ST3B

● NEMŢI LIMEA AŢĂCĂŢERII!
NICIŢI GĂLEŢERII AŢĂCĂŢERII!
NEMŢI LIMEA AŢĂCĂŢERII!
NICIŢI GĂLEŢERII AŢĂCĂŢERII!
NO CONSUMARE CUM SIBU!

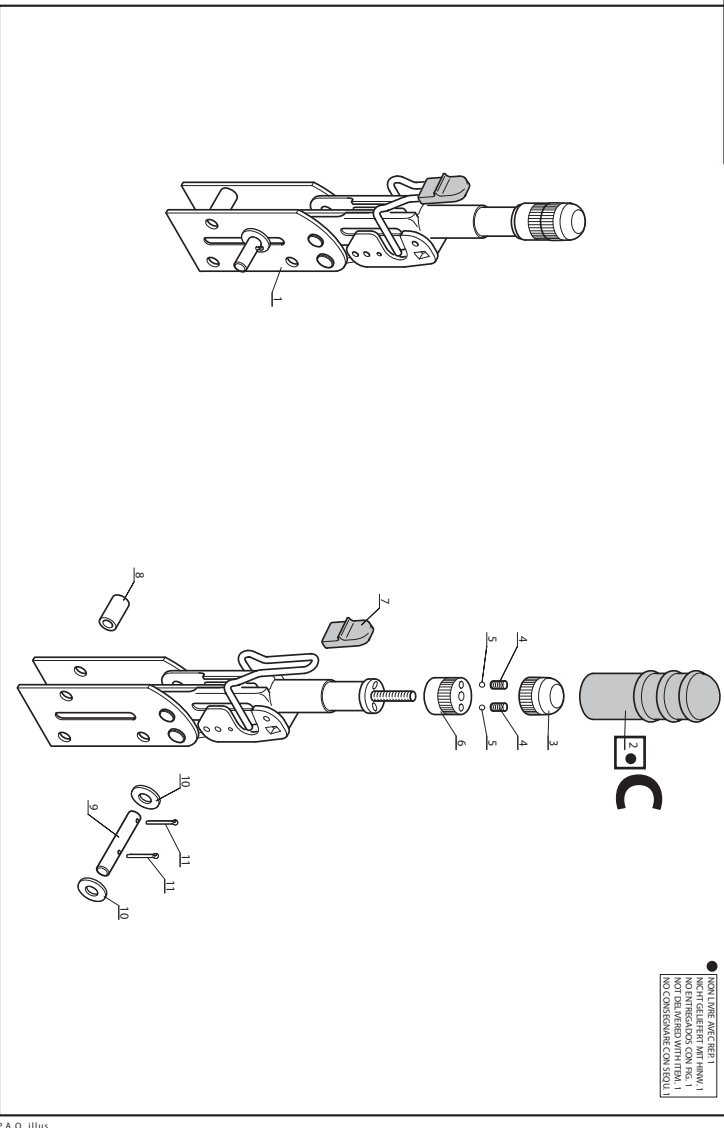

3x4 099 / 10
P.A.O. illus

POUR LES COMMANDES DE PIÈCES, PRÉCISEZ TOUJOURS :

- A - La référence du catalogue (Voir couverture)
- B - Numéro de la planche
- C - Repère de la pièce et quantité demandée
- D - Type de l'appareil, ainsi que son numéro dans la série

EXEMPLE DE COMMANDE :

Catalogue réf. : **647 122** Repère : **2**
Planche : **6 BA 122**
Qté : **1** Type de l'appareil : **M 30-2 ST3B**
N° dans la série : **796 276**

A l'aide de ces informations, votre agent MANITOU pourra identifier la référence de la pièce que vous désirez.

PARA LOS PEDIDOS DE RECAMBIOS, PRECISAR SIEMPRE :

- A - La referencia de catálogo (Ver portada)
- B - Número de la figura
- C - Señal de la pieza y cantidad deseada
- D - Tipo de la máquina, así como su número en la serie

EJEMPLO DE PEDIDOS

Catalogo ref: **647 122** Señal: **2**
Figura: **6 BA 122** Tipo de la maquina: **M 30-2 ST3B**
Cantidad: **1** Número en la serie: **796 276**

Con estas informaciones, su agente MANITOU podrá identificar la referencia de la pieza que usted quiere.

PER ORDINARE I PEZZI DI RICAMBIO, PRECISARE SEMPRE :

- A - Il riferimento del catalogo (Vedi copertina)
- B - Il numero della tavola
- C - Il riferimento del pezzo e la quantità richiesta
- D - Il tipo di macchina, e il suo numero nella serie

ESEMPIO DI ORDINE :

Catalogo rif. : **647 122** Riferimento : **2**
Tavola : **6 BA 122** Tipo di macchina : **M 30-2 ST3B**
Quantità : **1** N° nella serie : **796 276**

Con queste informazioni, il vostro agente MANITOU sarà in grado di identificare il riferimento del pezzo richiesto.

FÜR BESTELLUNGEN BITTE IMMER ANGEBEN :

- A - Nummer des Katalogs (Siehe Einband)
- B - Nummer der Seite
- C - Abbildung und Mengenbedarf
- D - Typ und Seriennummer des Staplers

BESTELLUNGSBEISPIEL :

Katalog nr. : **647 122** Abbildung: **2**
Seite : **6 BA 122** Stapler typ : **M 30-2 ST3B**
Menge : **1** Seriennummer : **796 276**

Nur mit Hilfe dieser Angaben kann ihr MANITOU Händler das gewünschte Teil heraus finden.

TO ORDER YOUR SPARE PARTS, ALWAYS STATE :

- A - The reference of the catalogue (See cover)
- B - Number of the figure
- C - Item of the part and quantity desired
- D - Type of the machine and its number in the serie

EXAMPLE OF ORDER :

Catalogue ref. : **647 122** Item : **2**
Figure : **6 BA 122** Type of the machine : **M 30-2 ST3B**
Quantity : **1** Number in the serie : **796 276**

With the above information, your MANITOU dealer can identify the number and proper part required.

2 AA 8000

FILTRES ET COURROIES
 FILTER UND KEBELBEMAS
 FILTERS Y CORRIAS
 FILTERS AND BELTS
 FILTROS E CINGHIA

M 26-2/4 ST3B	M 26-2/4H ST3B
M 30-2/4 ST3B	M 30-2/4H ST3B
M 40-2/4 ST3B	M 40-2/4H ST3B
M 50-2/4 ST3B	M 50-2/4H ST3B

01/08/14

3 AA 8001

ROUES AVANT
 VORN RAD
 RUEDAS DELANTERA
 FRONT WHEELS
 ANTRONRE RIJOTE

CONTINENTAL
 14.5 R 20 18PR MPT 80 TL

DUNLOP
 400/70-20 1508 T37 STAB 1508 TL

EVEREST
 18X19,5 18PR ST P30 TUB

MITAS
 18-22,5 163 AB MPT 06 TL

M 26-2/4 ST3B	M 26-2/4H ST3B
M 30-2/4 ST3B	M 30-2/4H ST3B
M 40-2/4 ST3B	M 40-2/4H ST3B
M 50-2/4 ST3B	M 50-2/4H ST3B

01/08/14

3 AA 8002

ROUES ARRIERE
 HINTERRAD
 RUEDAS TRASERA
 REAR WHEELS
 RUOTE POSTERIORE

GOOD YEAR
 108 17,5 134T30M G291 GY

DUNLOP
 10,5/80-18 10PR 16,42 TL

GOOD YEAR
 108 17,5 134T30M G291 GY

MICHELIN
 340 100T8 XNOL1 X13AB

M 26-2/4 ST3B	M 26-2/4H ST3B
M 30-2/4 ST3B	M 30-2/4H ST3B
M 40-2/4 ST3B	M 40-2/4H ST3B
M 50-2/4 ST3B	M 50-2/4H ST3B

01/08/14

4 AA 8003

ADAPTATION MOTEUR-TRANSMISSION
 MOTOR-GETRIEBE ANPASSUNG
 ADAPTACION MOTOR-TRANSMISION
 ENGINE TRANSMISSION ADAPTATION
 ADATTAMENTO MOTORE - TRASMISSIONE

M 26-2/4 ST3B	M 26-2/4H ST3B
M 30-2/4 ST3B	M 30-2/4H ST3B
M 40-2/4 ST3B	M 40-2/4H ST3B
M 50-2/4 ST3B	M 50-2/4H ST3B

01/08/14

4 AA 8004

ADAPTATION MOTEUR-TRANSMISSION
 MOTOR-GETRIEBE ANPASSUNG
 ADAPTACION MOTOR-TRANSMISION
 ENGINE TRANSMISSION ADAPTATION
 ADATTAMENTO MOTORE - TRASMISSIONE

See Electric Assembly

M 26-2/4 ST3B	M 26-2/4H ST3B
M 30-2/4 ST3B	M 30-2/4H ST3B
M 40-2/4 ST3B	M 40-2/4H ST3B
M 50-2/4 ST3B	M 50-2/4H ST3B

01/08/14

4 AA 8005

ADAPTATION MOTEUR-TRANSMISSION
 MOTOR-GETRIEBE ANPASSUNG
 ADAPTACION MOTOR-TRANSMISION
 ENGINE TRANSMISSION ADAPTATION
 ADATTAMENTO MOTORE - TRASMISSIONE

M 30-2/4 ST3B	M 26-2/4H ST3B
M 30-2/4 ST3B	M 30-2/4H ST3B
M 40-2/4 ST3B	M 40-2/4H ST3B
M 50-2/4 ST3B	M 50-2/4H ST3B

01/08/14

4 AA 8006

ADAPTATION MOTEUR-TRANSMISSION
 MOTOR-GETRIEBE ANPASSUNG
 ADAPTACION MOTOR-TRANSMISION
 ENGINE TRANSMISSION ADAPTATION
 ADATTAMENTO MOTORE - TRASMISSIONE

M 26-2/4 ST3B	M 26-2/4H ST3B
M 30-2/4 ST3B	M 30-2/4H ST3B
M 40-2/4 ST3B	M 40-2/4H ST3B
M 50-2/4 ST3B	M 50-2/4H ST3B

01/08/14

4 AA 8007

ADAPTATION MOTEUR-TRANSMISSION
 MOTOR-GETRIEBE ANPASSUNG
 ADAPTACION MOTOR-TRANSMISION
 ENGINE TRANSMISSION ADAPTATION
 ADATTAMENTO MOTORE - TRASMISSIONE

M 26-2/4 ST3B	M 26-2/4H S
M 30-2/4 ST3B	M 30-2/4H S

01/08/14

4 AA 8008

ADAPTATION MOTEUR-TRANSMISSION
 MOTOR-GETRIEBE ANPASSUNG
 ADAPTACION MOTOR-TRANSMISION
 ENGINE TRANSMISSION ADAPTATION
 ADATTAMENTO MOTORE - TRASMISSIONE

M 40-2/4 ST3B	M 40-2/4H ST3B
M 50-2/4 ST3B	M 50-2/4H ST3B

01/08/14



4 AA 8009

ADAPTATION MOTEUR-TRANSMISSION
MOTOR-GETRIEBE ANPASSUNG
ADAPTACION MOTOR-TRANSMISION
ENGINE-TRANSMISSION ADAPTATION
ADATTAMENTO MOTORE - TRASMISSIONE

M 26-2/4 ST3B M 30-2/4 ST3B M 26-2/4H ST3B M 30-2/4H ST3B

NOTE:
1. CONSULT THE PARTS LIST FOR THE CORRECT PARTS AND CONNECTIONS.
2. USE THE CORRECT HOSE AND CONNECTIONS.
3. USE THE CORRECT HOSE AND CONNECTIONS.

4 AA 8010

ADAPTATION MOTEUR-TRANSMISSION
MOTOR-GETRIEBE ANPASSUNG
ADAPTACION MOTOR-TRANSMISION
ENGINE-TRANSMISSION ADAPTATION
ADATTAMENTO MOTORE - TRASMISSIONE

M 40-2/4 ST3B M 40-2/4H ST3B M 50-2/4 ST3B M 50-2/4H ST3B

NOTE:
1. CONSULT THE PARTS LIST FOR THE CORRECT PARTS AND CONNECTIONS.
2. USE THE CORRECT HOSE AND CONNECTIONS.
3. USE THE CORRECT HOSE AND CONNECTIONS.

4 AB 8054

TRANSMISSION HYDROSTATIQUE
HYDROSTATISCHE GETRIEBE
TRANSMISION HIDROSTATICA
HYDROSTATIC TRANSMISSION
TRANSMISSIONE IDROSTATICA

M 26-2/4H ST3B M 30-2/4H ST3B M 40-2/4H ST3B M 50-2/4H ST3B

4 AB 8055

TRANSMISSION HYDROSTATIQUE
HYDROSTATISCHE GETRIEBE
TRANSMISION HIDROSTATICA
HYDROSTATIC TRANSMISSION
TRANSMISSIONE IDROSTATICA

M 26-2/4H ST3B M 30-2/4H ST3B M 40-2/4H ST3B M 50-2/4H ST3B

Hydraulic Tank use 10A834

NOTE:
1. CONSULT THE PARTS LIST FOR THE CORRECT PARTS AND CONNECTIONS.
2. USE THE CORRECT HOSE AND CONNECTIONS.
3. USE THE CORRECT HOSE AND CONNECTIONS.

4 AB 8056

TRANSMISSION HYDROSTATIQUE
HYDROSTATISCHE GETRIEBE
TRANSMISION HIDROSTATICA
HYDROSTATIC TRANSMISSION
TRANSMISSIONE IDROSTATICA

M 26-2/4H ST3B M 30-2/4H ST3B M 40-2/4H ST3B M 50-2/4H ST3B

HYDRAULIC SHIFTER LAYOUT

NOTE:
1. CONSULT THE PARTS LIST FOR THE CORRECT PARTS AND CONNECTIONS.
2. USE THE CORRECT HOSE AND CONNECTIONS.
3. USE THE CORRECT HOSE AND CONNECTIONS.

4 AB 8057

REFROIDISSEUR D'HUILE - HYDROSTATIQUE
ÖLKÜHLER - HYDROSTATISCHER
ENFRIGADOR DE ACEITE - HIDROSTATICA
OIL COOLER - HYDROSTATIC
RAFFREDDAMENTO DELL'OLIO - IDROSTATICO

M 26-2/4H ST3B M 30-2/4H ST3B M 40-2/4H ST3B M 50-2/4H ST3B

NOTE:
1. CONSULT THE PARTS LIST FOR THE CORRECT PARTS AND CONNECTIONS.
2. USE THE CORRECT HOSE AND CONNECTIONS.
3. USE THE CORRECT HOSE AND CONNECTIONS.

4 AC 8011

CIRCUIT COMBUSTIBLE
FUEL CIRCUIT
CIRCUITO COMBUSTIBLE
FUEL CIRCUIT
SISTEMA NAFTA

M 26-2/4 ST3B M 30-2/4 ST3B M 26-2/4H ST3B M 30-2/4H ST3B M 40-2/4H ST3B M 50-2/4H ST3B

NOTE:
1. CONSULT THE PARTS LIST FOR THE CORRECT PARTS AND CONNECTIONS.
2. USE THE CORRECT HOSE AND CONNECTIONS.
3. USE THE CORRECT HOSE AND CONNECTIONS.

5 AA 8061

MAT - DEPLACEMENT LATERAL KIT
MAST - SEITENSCHIEBUNG-KIT
MASTL - KIT DE DESPLAZADOR LATERAL
MAST - SIDE SHIFT KIT
MAST - KIT SPOSTAMENTO LATERALE

M 40-2/4 ST3BM M 40-2/4H ST3B M 50-4/4 ST3BM M 50-4/4H ST3B

NOTE:
Attach to Frame
Befestigen Sie den Rahmenart
Attacher au chassis
Adjuntar a Chassis
Fissare al Telaio

5 AA 8062

MAT - DEPLACEMENT LATERAL KIT
MAST - SEITENSCHIEBUNG-KIT
MASTL - KIT DE DESPLAZADOR LATERAL
MAST - SIDE SHIFT KIT
MAST - KIT SPOSTAMENTO LATERALE

M 26-2/4 ST3BM M 30-2/4 ST3BM M 26-2/4H ST3B M 30-2/4H ST3B

NOTE:
Attach to Frame
Befestigen Sie den Rahmenart
Attacher au chassis
Adjuntar a Chassis
Fissare al Telaio



6 AA 8012

CHASSIS - CONTREPOIDS
 GESTELL - GEGENGEWICHT
 BASTIDON - CONTRAPESO
 FRAME - COUNTERWEIGHT
 TELAO - CONTRAPPESO

M 26-2/4 ST3B M 26-2/4H ST3B
 M 30-2/4 ST3B M 30-2/4H ST3B

ATTENZIONE: LA MACCHINA
 DEVE ESSERE MONTATA
 SULLA MACCHINA
 PRIMA DI ACCENDERE
 IL MOTORE.

● → 796 281
 ○ → 796 282

6 AA 8013

CHASSIS - CONTREPOIDS
 GESTELL - GEGENGEWICHT
 BASTIDON - CONTRAPESO
 FRAME - COUNTERWEIGHT
 TELAO - CONTRAPPESO

M 40-2/4 ST3B M 40-2/4H ST3B
 M 50-2/4 ST3B M 50-2/4H ST3B

ATTENZIONE: LA MACCHINA
 DEVE ESSERE MONTATA
 SULLA MACCHINA
 PRIMA DI ACCENDERE
 IL MOTORE.

● → 796 281
 ○ → 796 282

6 BA 8014

FREN A MAIN
 HANDBREMSE
 FRENO DE MANO
 HANDBRAKE
 FRENO A MANO

M 26-2/4 ST3B M 26-2/4H ST3B
 M 30-2/4 ST3B M 30-2/4H ST3B
 M 40-2/4 ST3B M 40-2/4H ST3B
 M 50-2/4 ST3B M 50-2/4H ST3B

● (COTESE) (MONTARE)
 (NOT CALLED BY ITEM 1)
 (NOT CALLED BY ITEM 1)
 (NOT CALLED BY ITEM 1)

6 BA 8015

CIRCUIT FRENAGE
 BREMSKREIS
 CIRCUITO FRENO
 BRAKE CIRCUIT
 CIRCUITO FREMANTE

M 26-2/4 ST3B M 26-2/4H ST3B
 M 30-2/4 ST3B M 30-2/4H ST3B
 M 40-2/4 ST3B M 40-2/4H ST3B
 M 50-2/4 ST3B M 50-2/4H ST3B

POUTURE: PER BOMBE
 (FOR PUMP)
 (FOR PUMP)

POUTURE PER BOMBE
 (FOR PUMP)
 (FOR PUMP)

POUTURE PER BOMBE
 (FOR PUMP)
 (FOR PUMP)

6 BB 8016

PEDALERIE - TRINGLERIE
 PEDALES - GESTANGE
 PEDALES - VARILLAS
 PEDALS - LINKAGE
 PEDALS - COMMAND

M 26-2/4 ST3B
 M 30-2/4 ST3B
 M 40-2/4 ST3B
 M 50-2/4 ST3B

7 AA 8017

ESSIEU ARRIERE
 HINTERACHSE
 EJE TRASERO
 REAR AXLE
 PONTE POSTERIORE

M 26-2 ST3B M 26-2H ST3B
 M 30-2 ST3B M 30-2H ST3B



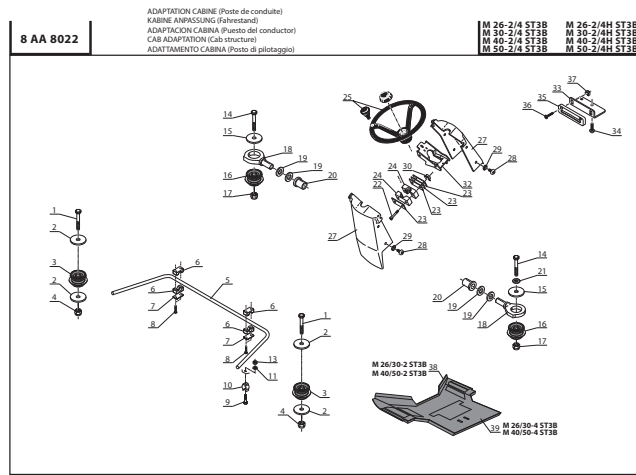
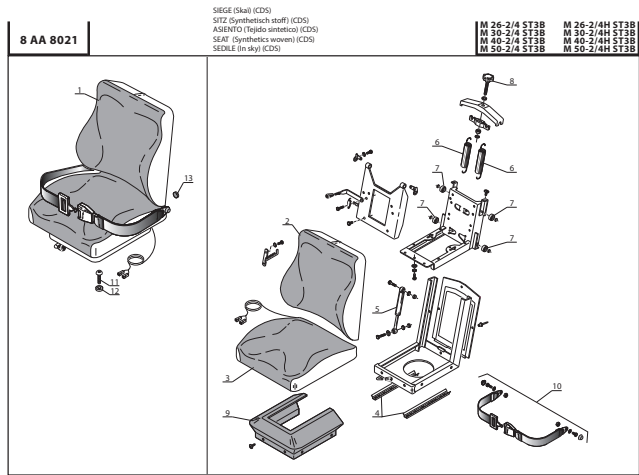
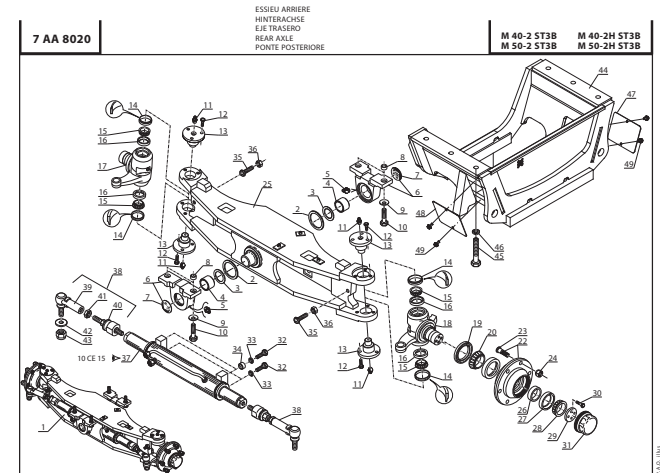
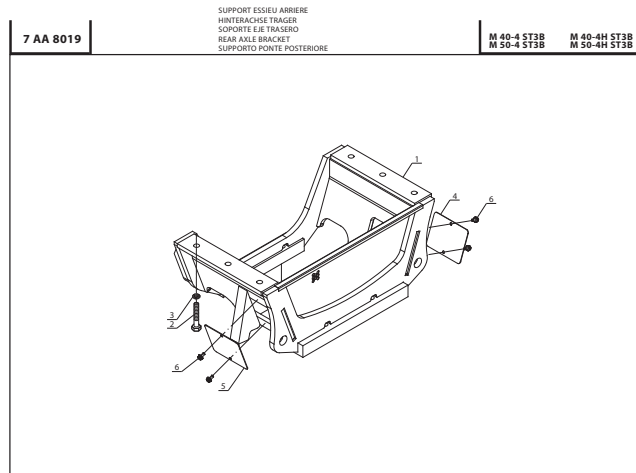
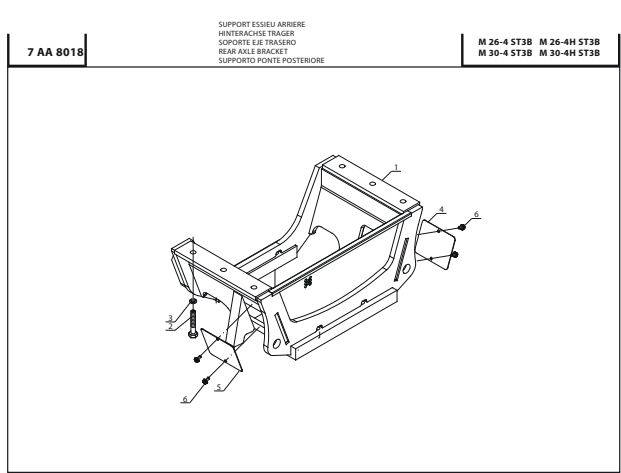

PROTEGE-CONDUCTEUR
FÜHRER SCHUTZVORRICHTUNG
PROTECTOR CONDUCTOR
DRIVER'S OVERHEAD GUARD
PROTEZIONE CONDUCENTE

N° 309 842



8 AB 8058

PROTEGE-CONDUCTEUR (Details)
 FÜHRER-SCHUTZVORRICHTUNG (Einzelteile)
 PROTECTOR CONDUCTOR (Details)
 DRIVER'S OVERHEAD GUARD (Details)
 PROTEZIONE CONDUCENTE (Dettaglio)

M 26-2/4 ST3B
 M 30-2/4 ST3B
 M 40-2/4 ST3B
 M 50-2/4 ST3B

CLÔTURE DU CABINE
 CABIN GLAZ TSTELLUNG
 CERRIE DE CABINA
 CAB CLOSE OUT
 CHIUSURA DEL CABINA

C3 309 842

8 AB 1409

PROTEGE-CONDUCTEUR (Details)
 FÜHRER-SCHUTZVORRICHTUNG (Einzelteile)
 PROTECTOR CONDUCTOR (Details)
 DRIVER'S OVERHEAD GUARD (Details)
 PROTEZIONE CONDUCENTE (Dettaglio)

M 26-2/4 ST3B
 M 30-2/4 ST3B
 M 40-2/4 ST3B
 M 50-2/4 ST3B

M 26-2/4H ST3B
 M 30-2/4H ST3B
 M 40-2/4H ST3B
 M 50-2/4H ST3B

Metallnetz avoid collapse
 Before further installation
 please refer to the following
 instructions: *Chiusura prima dell'installazione*

C3 309 842

8 AB 1410

PROTEGE-CONDUCTEUR (Details)
 FÜHRER-SCHUTZVORRICHTUNG (Einzelteile)
 PROTECTOR CONDUCTOR (Details)
 DRIVER'S OVERHEAD GUARD (Details)
 PROTEZIONE CONDUCENTE (Dettaglio)

M 26-2/4 ST3B
 M 30-2/4 ST3B
 M 40-2/4 ST3B
 M 50-2/4 ST3B

M 26-2/4H ST3B
 M 30-2/4H ST3B
 M 40-2/4H ST3B
 M 50-2/4H ST3B

C3 309 842

8 AB 1411

PROTEGE-CONDUCTEUR (Details)
 FÜHRER-SCHUTZVORRICHTUNG (Einzelteile)
 PROTECTOR CONDUCTOR (Details)
 DRIVER'S OVERHEAD GUARD (Details)
 PROTEZIONE CONDUCENTE (Dettaglio)

M 26-2/4 ST3B
 M 30-2/4 ST3B
 M 40-2/4 ST3B
 M 50-2/4 ST3B

M 26-2/4H ST3B
 M 30-2/4H ST3B
 M 40-2/4H ST3B
 M 50-2/4H ST3B

C3 309 842

9 AA 8023

CARROSSERIE
 KAROSSERIE
 CARROCERIA
 BODY
 CARROZZERIA

M 30-2 ST3B
 M 30-2H ST3B

M 30-2H ST3B
 M 30-2H ST3B

See Fender Group

C3 309 842

9 AA 8024

CARROSSERIE
 KAROSSERIE
 CARROCERIA
 BODY
 CARROZZERIA

M 30-4 ST3B
 M 30-4H ST3B

M 30-4H ST3B
 M 30-4H ST3B

See Fender Group

C3 309 842

9 AA 8025

CARROSSERIE
 KAROSSERIE
 CARROCERIA
 BODY
 CARROZZERIA

M 40-4 ST3B
 M 40-4H ST3B

M 40-4H ST3B
 M 40-4H ST3B

See Fender Group

C3 309 842

9 AA 8026

CARROSSERIE
 KAROSSERIE
 CARROCERIA
 BODY
 CARROZZERIA

M 40-2 ST3B
 M 40-2H ST3B

M 40-2H ST3B
 M 40-2H ST3B

See Fender Group

C3 309 842

9 AB 8027

CARROSSERIE (INSONORISANT)
 KAROSSERIE (SCHALLDÄMPFUNGSMOODS)
 CARROCERIA (INSONORIZADOR)
 BODY SOUND PROOFING (FOAM)
 CARROZZERIA (AMMORTIZZATORE)

M 26-2 ST3B
 M 30-2 ST3B

M 26-2H ST3B
 M 30-2H ST3B

PROVA LA VERSIONE
 DEL CUBO MASCHINE
 PRIMA DI MONTARE
 IL PAVIMENTO
 PER LA MACCHINA

● → 796 281
 PER INFORMAZIONI
 AL CUBO MASCHINE
 FARETELEFONO AL NUMERO
 VERDE 800 20 20 20
 O VISITATE IL SITO
 WWW.CAT.COM

C3 309 842



9 AB 8028

CARROSSERIE (INSONDRISANT)
CARROSSERIE (SCHALLDÄMPFUNGSMOOD)
CARROSSERIA (INSONORIZAZIONE)
BODY (SOUND PROOFING FOAM)
CARROZZERIA (AMMORTIZZAZIONE)

M 26-4 ST3B M 26-4H ST3B
M 30-4 ST3B M 30-4H ST3B

ASSEMBLA LA MACCHINA
ASSEMBLE THE MACHINE
ASSEMBLA LA MACCHINA
ASSEMBLE LA MACCHINA
ASSEMBLA LA MACCHINA
ASSEMBLE LA MACCHINA

● → 796 281
ATTENZIONE LA MACCHINA
ATTENTION THE MACHINE
ATTENCIÓN LA MÁQUINA
ATTENÇÃO A MÁQUINA
ATTENZIONE LA MACCHINA
ATTENÇÃO A MÁQUINA

○ → 796 282

9 AB 8029

CARROSSERIE (INSONDRISANT)
CARROSSERIE (SCHALLDÄMPFUNGSMOOD)
CARROSSERIA (INSONORIZAZIONE)
BODY (SOUND PROOFING FOAM)
CARROZZERIA (AMMORTIZZAZIONE)

M 40-4 ST3B M 40-4H ST3B
M 50-4 ST3B M 50-4H ST3B

ASSEMBLA LA MACCHINA
ASSEMBLE THE MACHINE
ASSEMBLA LA MACCHINA
ASSEMBLE LA MACCHINA
ASSEMBLA LA MACCHINA
ASSEMBLE LA MACCHINA

● → 796 281
ATTENZIONE LA MACCHINA
ATTENTION THE MACHINE
ATTENCIÓN LA MÁQUINA
ATTENÇÃO A MÁQUINA
ATTENZIONE LA MACCHINA
ATTENÇÃO A MÁQUINA

○ → 796 282

9 AB 8030

CARROSSERIE (INSONDRISANT)
CARROSSERIE (SCHALLDÄMPFUNGSMOOD)
CARROSSERIA (INSONORIZAZIONE)
BODY (SOUND PROOFING FOAM)
CARROZZERIA (AMMORTIZZAZIONE)

M 40-2 ST3B M 40-2H ST3B
M 50-2 ST3B M 50-2H ST3B

ASSEMBLA LA MACCHINA
ASSEMBLE THE MACHINE
ASSEMBLA LA MACCHINA
ASSEMBLE LA MACCHINA
ASSEMBLA LA MACCHINA
ASSEMBLE LA MACCHINA

● → 796 281
ATTENZIONE LA MACCHINA
ATTENTION THE MACHINE
ATTENCIÓN LA MÁQUINA
ATTENÇÃO A MÁQUINA
ATTENZIONE LA MACCHINA
ATTENÇÃO A MÁQUINA

○ → 796 282

10 AA 8031

HYDRAULIQUE (Circuit principal)
HYDRAULIK (Hauptkreis)
HYDRAULICO (Circuito principal)
HYDRAULIC (Principal circuit)
IDRAULICO (Circuito principale)

M 26-2/4 ST3B M 26-2/4H ST3B
M 30-2/4 ST3B M 30-2/4H ST3B
M 40-2/4 ST3B M 40-2/4H ST3B
M 50-2/4 ST3B M 50-2/4H ST3B

● → 796 281
ATTENZIONE LA MACCHINA
ATTENTION THE MACHINE
ATTENCIÓN LA MÁQUINA
ATTENÇÃO A MÁQUINA
ATTENZIONE LA MACCHINA
ATTENÇÃO A MÁQUINA

○ → 796 282

4th Spool Option

10 AB 8032

HYDRAULIQUE (Circuit inclination - Elevation)
HYDRAULIK (Neigung - Aufwärtsschieben)
HYDRAULICO (Circuito inclinación - Elevación)
HYDRAULIC (Tilting - Lifting circuit)
IDRAULICO (Circuito inclinazione - Sollevamento)

M 26-2/4 ST3B M 26-2/4H ST3B
M 30-2/4 ST3B M 30-2/4H ST3B

● → 796 281
ATTENZIONE LA MACCHINA
ATTENTION THE MACHINE
ATTENCIÓN LA MÁQUINA
ATTENÇÃO A MÁQUINA
ATTENZIONE LA MACCHINA
ATTENÇÃO A MÁQUINA

○ → 796 282

10 AB 8033

HYDRAULIQUE (Circuit inclination - Elevation)
HYDRAULIK (Neigung - Aufwärtsschieben)
HYDRAULICO (Circuito inclinación - Elevación)
HYDRAULIC (Tilting - Lifting circuit)
IDRAULICO (Circuito inclinazione - Sollevamento)

M 40-2/4 ST3B M 40-2/4H ST3B
M 50-2/4 ST3B M 50-2/4H ST3B

● → 796 281
ATTENZIONE LA MACCHINA
ATTENTION THE MACHINE
ATTENCIÓN LA MÁQUINA
ATTENÇÃO A MÁQUINA
ATTENZIONE LA MACCHINA
ATTENÇÃO A MÁQUINA

○ → 796 282

10 AM 8034

HYDRAULIQUE (Circuit blocage différentiel)
HYDRAULIK (Differentialblockierungskreis)
HYDRAULICO (Circuito bloqueo diferencial)
HYDRAULIC (Differential locking circuit)
IDRAULICO (Circuito bloccaggio differenziale)

M 26-2 ST3B M 26-2H ST3B
M 30-2 ST3B M 30-2H ST3B
M 40-2 ST3B M 40-2H ST3B
M 50-2 ST3B M 50-2H ST3B

● → 796 281
ATTENZIONE LA MACCHINA
ATTENTION THE MACHINE
ATTENCIÓN LA MÁQUINA
ATTENÇÃO A MÁQUINA
ATTENZIONE LA MACCHINA
ATTENÇÃO A MÁQUINA

○ → 796 282

10 AA 8059

TRANSMISSION HYDROSTATIQUE
HYDROSTATISCHE GETRIEBE
TRANSMISSION HIDROSTÁTICA
HYDROSTATIC TRANSMISSION
TRANSMISSIONE IDROSTATICA

M 26-2/4H ST3B
M 30-2/4H ST3B
M 40-2/4H ST3B
M 50-2/4H ST3B

● → 796 281
ATTENZIONE LA MACCHINA
ATTENTION THE MACHINE
ATTENCIÓN LA MÁQUINA
ATTENÇÃO A MÁQUINA
ATTENZIONE LA MACCHINA
ATTENÇÃO A MÁQUINA

○ → 796 282

Assembly Torque
10 DaN/m MAX

* 4th Spool
Option Only

10 AD 8063

MAT - DÉPLACEMENT LATÉRAL HYDRAULIQUE KIT
MAST - HYDRAULISCHE SEITENSCHIEBUNG KIT
MAST - KIT DE DESPLAZAMIENTO LATERAL IDRAULICO
MAST - SIDE SHIFT HYDRAULIC KIT
MAST - KIT IDRAULICO SPOSTAMENTO LATERALE

M 26-2/4 ST3BM M 26-2/4H ST3B
M 30-2/4 ST3BM M 30-2/4H ST3B
M 40-2/4 ST3BM M 40-2/4H ST3B
M 50-4/4 ST3BM M 50-4/4H ST3B

● → 796 281
ATTENZIONE LA MACCHINA
ATTENTION THE MACHINE
ATTENCIÓN LA MÁQUINA
ATTENÇÃO A MÁQUINA
ATTENZIONE LA MACCHINA
ATTENÇÃO A MÁQUINA

○ → 796 282



10 BA 8035

HYDRAULIQUE (Circuit direction)
 HYDRAULIK (Lenkungsleitkreis)
 HYDRAULICO (Circuito direction)
 HYDRAULIC (Steering circuit)
 IDRAULICO (Circuito sterzo)

M 26-2 ST3B	M 26-2H ST3B
M 30-2 ST3B	M 30-2H ST3B
M 40-2 ST3B	M 40-2H ST3B
M 50-2 ST3B	M 50-2H ST3B

■ **REQUISITI PER IL KIT**
 ELEMENTI PER KIT
 C3M 30-2 ST3B
 ELEMENTI PER KIT
 ELEMENTI PER KIT
 C3M 50-2 ST3B

NOTE: 10 BA 368, 10 EA 23, 7 AA 85, 7 AA 82

10 BA 8036

HYDRAULIQUE (Circuit direction)
 HYDRAULIK (Lenkungsleitkreis)
 HYDRAULICO (Circuito direction)
 HYDRAULIC (Steering circuit)
 IDRAULICO (Circuito sterzo)

M 26-4 ST3B	M 26-4H ST3B
M 30-4 ST3B	M 30-4H ST3B
M 40-4 ST3B	M 40-4H ST3B
M 50-4 ST3B	M 50-4H ST3B

■ **REQUISITI PER IL KIT**
 ELEMENTI PER KIT
 C3M 30-4 ST3B
 ELEMENTI PER KIT
 ELEMENTI PER KIT
 C3M 50-4 ST3B

NOTE: 10 BA 368, 10 EA 240, 7 AA 85, 7 AA 82

10 CD 8037

HYDRAULIQUE (Vérin d'inclinaison) (Inclinaison standard 15°/15°)
 HYDRAULIK (Neigungszylinder) (Standard neigung 15°/15°)
 HYDRAULICO (Cilindro di inclinazione) (Inclinaison standard 15°/15°)
 HYDRAULIC (Tilting cylinder) (Standard tilting 15°/15°)
 IDRAULICO (Cilindro di inclinazione) (Inclinaison standard 15°/15°)

M 40-2/4 ST3B	M 40-2/4H ST3B
M 50-2/4 ST3B	M 50-2/4H ST3B

■ **REQUISITI PER IL KIT**
 ELEMENTI PER KIT
 ELEMENTI PER KIT
 ELEMENTI PER KIT
 ELEMENTI PER KIT

NOTE: 219632

10 CD 8038

HYDRAULIQUE (Vérin d'inclinaison) (Inclinaison standard 6°/12°)
 HYDRAULIK (Neigungszylinder) (Standard neigung 6°/12°)
 HYDRAULICO (Cilindro di inclinazione) (Inclinaison standard 6°/12°)
 HYDRAULIC (Tilting cylinder) (Standard tilting 6°/12°)
 IDRAULICO (Cilindro di inclinazione) (Inclinaison standard 6°/12°)

M 30-2/4 ST3B	M 30-2/4H ST3B
M 30-2/4 ST3B	M 30-2/4H ST3B

■ **REQUISITI PER IL KIT**
 ELEMENTI PER KIT
 ELEMENTI PER KIT
 ELEMENTI PER KIT
 ELEMENTI PER KIT

NOTE: 218634

10 CE 8039

HYDRAULIQUE (Vérin de direction)
 HYDRAULIK (Lenkungszyylinder)
 HYDRAULICO (Cilindro de direction)
 HYDRAULIC (Steering cylinder)
 IDRAULICO (cilindro di sterzo)

M 40-2 ST3B	M 40-2H ST3B
M 50-2 ST3B	M 50-2H ST3B

■ **REQUISITI PER IL KIT**
 ELEMENTI PER KIT
 ELEMENTI PER KIT
 ELEMENTI PER KIT
 ELEMENTI PER KIT

NOTE: 200 216

10 CE 8040

HYDRAULIQUE (Vérin de direction)
 HYDRAULIK (Lenkungszyylinder)
 HYDRAULICO (Cilindro de direction)
 HYDRAULIC (Steering cylinder)
 IDRAULICO (cilindro di sterzo)

M 26-2 ST3B	M 26-2H ST3B
M 30-2 ST3B	M 30-2H ST3B

■ **REQUISITI PER IL KIT**
 ELEMENTI PER KIT
 ELEMENTI PER KIT
 ELEMENTI PER KIT
 ELEMENTI PER KIT

NOTE: 256 807

10 DA 8041

HYDRAULIQUE (Vérin de direction)
 HYDRAULIK (Lenkungszyylinder)
 HYDRAULICO (Cilindro de direction)
 HYDRAULIC (Steering cylinder)
 IDRAULICO (cilindro di sterzo)

DISTRIBUITEUR
 COMMANDOCENTRIERMENT
 DISTRIBUTOR
 VALVE BANK
 DISTRIBUTOR

M 26-2/4 ST3B	M 26-2/4H ST3B
M 30-2/4 ST3B	M 30-2/4H ST3B
M 40-2/4 ST3B	M 40-2/4H ST3B
M 50-2/4 ST3B	M 50-2/4H ST3B

■ **REQUISITI PER IL KIT**
 ELEMENTI PER KIT
 ELEMENTI PER KIT
 ELEMENTI PER KIT
 ELEMENTI PER KIT

NOTE: 796 282

10 EA 8042

HYDRAULIQUE (Détail)
 HYDRAULIK (Einzelteil)
 HYDRAULICO (Dettaglio)
 HYDRAULIC (Detail)
 IDRAULICO (Dettaglio)

M 26-2/4 ST3B	M 26-2/4H ST3B
M 30-2/4 ST3B	M 30-2/4H ST3B
M 40-2/4 ST3B	M 40-2/4H ST3B
M 50-2/4 ST3B	M 50-2/4H ST3B

■ **REQUISITI PER IL KIT**
 ELEMENTI PER KIT
 ELEMENTI PER KIT
 ELEMENTI PER KIT
 ELEMENTI PER KIT

11 AA 8043

CIRCUIT ELECTRIQUE
 STRUONIERI
 CIRCUITO ELETTRICO
 ELECTRIC CIRCUIT
 IMPIANTO ELETTRICO

M 26-2/4 ST3B	M 26-2/4H ST3B
M 30-2/4 ST3B	M 30-2/4H ST3B

■ **REQUISITI PER IL KIT**
 ELEMENTI PER KIT
 ELEMENTI PER KIT
 ELEMENTI PER KIT
 ELEMENTI PER KIT



11 AA 8044

CIRCUIT ELECTRIQUE
STRÖMVERK
CIRCUITO ELECTRICO
ELECTRIC CIRCUIT
IMPIANTO ELETTRICO

M 40-2/4 ST3B M 40-2/4H ST3B
M 50-2/4 ST3B M 50-2/4H ST3B

11 AA 8045

CIRCUIT ELECTRIQUE
STRÖMVERK
CIRCUITO ELECTRICO
ELECTRIC CIRCUIT
IMPIANTO ELETTRICO

M 26-2/4H ST3B M 26-2/4H ST3B
M 30-2/4H ST3B M 30-2/4H ST3B
M 40-2/4H ST3B M 40-2/4H ST3B
M 50-2/4H ST3B M 50-2/4H ST3B

LEGENDA
 ■ PER LA MANICHA
 ■ PER LA MANICHA
 ■ PER LA MANICHA
 ■ PER LA MANICHA

● → 796 281
 ■ PER LA MANICHA
 ■ PER LA MANICHA
 ■ PER LA MANICHA
 ■ PER LA MANICHA

○ 14 → 796 282

11 CB 8046

ELECTRICITE (Details)
ELEKTRIZITÄT (Einzelheiten)
ELECTRICIDAD (Detalles)
ELECTRICITY (Details)
ELETTRICITÀ (Dettaglio)

M 26-2/4 ST3B M 26-2/4H ST3B
M 30-2/4 ST3B M 30-2/4H ST3B
M 40-2/4 ST3B M 40-2/4H ST3B
M 50-2/4 ST3B M 50-2/4H ST3B

11 CB 8047

ELECTRICITE (Details)
ELEKTRIZITÄT (Einzelheiten)
ELECTRICIDAD (Detalles)
ELECTRICITY (Details)
ELETTRICITÀ (Dettaglio)

M 26-2/4 ST3B M 26-2/4H ST3B
M 30-2/4 ST3B M 30-2/4H ST3B
M 40-2/4 ST3B M 40-2/4H ST3B
M 50-2/4 ST3B M 50-2/4H ST3B

11 CC 8048

ELECTRICITE (Piste de conduite)
ELEKTRIZITÄT (Fahrerstand)
ELECTRICIDAD (Puesto del conductor)
ELECTRICITY (Cab structure)
ELETTRICITÀ (Pisto di pilotaggio)

M 26-2/4 ST3B M 26-2/4H ST3B
M 30-2/4 ST3B M 30-2/4H ST3B
M 40-2/4 ST3B M 40-2/4H ST3B
M 50-2/4 ST3B M 50-2/4H ST3B

11 CC 8049

ELECTRICITE (Piste de conduite)
ELEKTRIZITÄT (Fahrerstand)
ELECTRICIDAD (Puesto del conductor)
ELECTRICITY (Cab structure)
ELETTRICITÀ (Pisto di pilotaggio)

M 26-2/4 ST3B M 26-2/4H ST3B
M 30-2/4 ST3B M 30-2/4H ST3B
M 40-2/4 ST3B M 40-2/4H ST3B
M 50-2/4 ST3B M 50-2/4H ST3B

11 CD 8050

ELECTRICITE (Moteur - Transmission)
ELEKTRIZITÄT (Motor - Getriebe)
ELECTRICIDAD (Motor - Transmission)
ELECTRICITY (Engine - Transmission)
ELETTRICITÀ (Motore - Trasmissione)

M 26-2/4 ST3B M 26-2/4H ST3B
M 30-2/4 ST3B M 30-2/4H ST3B
M 40-2/4 ST3B M 40-2/4H ST3B
M 50-2/4 ST3B M 50-2/4H ST3B

11 CD 8060

SCHEMA - HIDROSTATIQUE
SCHEMA - HIDROSTATICO
SCHEMA - HIDROSTATICO
SCHEMA - HIDROSTATICA

26-2/4H ST3B
30-2/4H ST3B
40-2/4H ST3B
50-4/4H ST3B



MOTEUR - MOTOR MOTOR - ENGINE MOTORE

<p>TYPE - TYPEN TIPO - TYPE TIPO</p>	<p>JS 71001</p>
<p>REFERENCE - NUMBER NUMERO - NUMBER RIFERIMENTO</p>	<p>298 453</p>

<p>AP 8064</p> <p><small>FIGURAZIONE DESIGNATION REDAZIONE REDAZIONE REDAZIONE REDAZIONE</small></p> <p><small>C3 n° JS 71001 C3 n° 298 453</small></p>	<p><small>MOTOR ANPASSUNG ADAPTACION MOTOR ENGINE ADAPTATION ADATTAMENTO MOTORE</small></p>	<p><small>M 26-2/4 ST3B M 26-2/4H ST3B M 30-2/4 ST3B M 30-2/4H ST3B M 40-2/4 ST3B M 40-2/4H ST3B M 50-2/4 ST3B M 50-2/4H ST3B</small></p>

<p>AP 3244</p> <p><small>FIGURAZIONE DESIGNATION REDAZIONE REDAZIONE REDAZIONE</small></p> <p><small>C3 n° JS 71001 C3 n° 298 453</small></p>	<p><small>BLOC CYLINDRES CYLINDER BLOCK BLOQUE DE CILINDROS CYLINDER BLOCK MONOBLOCCO CILINDRO</small></p>	<p><small>M 26-2/4 ST3B M 26-2/4H ST3B M 30-2/4 ST3B M 30-2/4H ST3B M 40-2/4 ST3B M 40-2/4H ST3B M 50-2/4 ST3B M 50-2/4H ST3B</small></p>

<p>AP 3245</p> <p><small>FIGURAZIONE DESIGNATION REDAZIONE REDAZIONE REDAZIONE</small></p> <p><small>C3 n° JS 71001 C3 n° 298 453</small></p>	<p><small>PISTONS - BIELLES - VILEBREQUIN KOLBEN - Pleuelstange - Pleuelhelle PISTONS - BIELAS - CIGUEÑAL PISTONS - CONNECTING RODS - CRANK SHAFT PISTON - BIELLE - ALBERO A MANOVELLA</small></p>	<p><small>M 26-2/4 ST3B M 26-2/4H ST3B M 30-2/4 ST3B M 30-2/4H ST3B M 40-2/4 ST3B M 40-2/4H ST3B M 50-2/4 ST3B M 50-2/4H ST3B</small></p>

<p>AP 3246</p> <p><small>FIGURAZIONE DESIGNATION REDAZIONE REDAZIONE REDAZIONE</small></p> <p><small>C3 n° JS 71001 C3 n° 298 453</small></p>	<p><small>CULASSE ZYLINDERKOPF CULATA CYLINDER HEAD TESTATA</small></p>	<p><small>M 26-2/4 ST3B M 26-2/4H ST3B M 30-2/4 ST3B M 30-2/4H ST3B M 40-2/4 ST3B M 40-2/4H ST3B M 50-2/4 ST3B M 50-2/4H ST3B</small></p>

<p>AP 3247</p> <p><small>FIGURAZIONE DESIGNATION REDAZIONE REDAZIONE REDAZIONE</small></p> <p><small>C3 n° JS 71001 C3 n° 298 453</small></p>	<p><small>RAMPE DES CULBUTEURS KIPPEHUELLEN PERFIL DE BALANÇIN ROCKER ARM SHAFT ASSE A BILANCIERI</small></p>	<p><small>M 26-2/4 ST3B M 26-2/4H ST3B M 30-2/4 ST3B M 30-2/4H ST3B M 40-2/4 ST3B M 40-2/4H ST3B M 50-2/4 ST3B M 50-2/4H ST3B</small></p>

<p>AP 3248</p> <p><small>FIGURAZIONE DESIGNATION REDAZIONE REDAZIONE REDAZIONE</small></p> <p><small>C3 n° JS 71001 C3 n° 298 453</small></p>	<p><small>DISTRIBUTION ET ARBRE A CAMES STRIEBERTRIEBE UND Nockenwelle DISTRIBUCION Y ARBOL DE LEVAS TIMING GEAR AND CRANKSHAFT INGRANAGGIO E ALBERO DELLA DISTRIBUZIONE</small></p>	<p><small>M 26-2/4 ST3B M 26-2/4H ST3B M 30-2/4 ST3B M 30-2/4H ST3B M 40-2/4 ST3B M 40-2/4H ST3B M 50-2/4 ST3B M 50-2/4H ST3B</small></p>

<p>AP 3249</p> <p><small>FIGURAZIONE DESIGNATION REDAZIONE REDAZIONE REDAZIONE</small></p> <p><small>C3 n° JS 71001 C3 n° 298 453</small></p>	<p><small>CARTER DE DISTRIBUTION VENTILERSHAUSE CARTER DE DISTRIBUCION TIMING GEAR HOUSING CARTER DI DISTRIBUZIONE</small></p>	<p><small>M 26-2/4 ST3B M 26-2/4H ST3B M 30-2/4 ST3B M 30-2/4H ST3B M 40-2/4 ST3B M 40-2/4H ST3B M 50-2/4 ST3B M 50-2/4H ST3B</small></p>



AP 3250

<p>POUR MOTOR FOR MOTOR FOR ENGINE FOR DIESEL C21: J5 71001 C22: 298 433</p>	<p>CARTER D' HUILE - POMPE A HUILE OIL PANNE - SCHMIERPUMPE CARTER DE ACEITE - BOMBA DE ACEITE OIL SUMP - LUBRICATING OIL PUMP COPRA GLIO - POMPA LUBBRIFICAZIONE</p>	<p>M 26-2/4 ST3B M 30-2/4 ST3B M 30-2/4H ST3B M 40-2/4 ST3B M 40-2/4H ST3B M 50-2/4 ST3B M 50-2/4H ST3B</p>
--	--	--

01/06/14 P. 16/16

AP 3251

<p>POUR MOTOR FOR MOTOR FOR ENGINE FOR DIESEL C21: J5 71001 C22: 298 433</p>	<p>CACHE CULBUTEUR ET RENFLIARD KIPPHEBELCKEL UND ENTLUFTFERNER TAPA DE BALANCIER Y RESFRASCO ROCKER LEVER COVER AND BREATHER PATA BILANCIERE E SFERAZIO</p>	<p>M 26-2/4 ST3B M 30-2/4 ST3B M 30-2/4H ST3B M 40-2/4 ST3B M 40-2/4H ST3B M 50-2/4 ST3B M 50-2/4H ST3B</p>
--	---	--

01/06/14 P. 16/16

AP 3252

<p>POUR MOTOR FOR MOTOR FOR ENGINE FOR DIESEL C21: J5 71001 C22: 298 433</p>	<p>FILTRE A HUILE ET REFRIGERISSEUR D' HUILE SCHMIER OELFILTER UND MOTORSTUECKER OELKUEHLER FILTRO Y ENFRASADOR INTEGRAL LUBRICATING OIL FILTER AND INTEGRAL OIL COOLER FILTRO OLIO E REFRIGERAZIONE</p>	<p>M 26-2/4 ST3B M 30-2/4 ST3B M 30-2/4H ST3B M 40-2/4 ST3B M 40-2/4H ST3B M 50-2/4 ST3B M 50-2/4H ST3B</p>
--	---	--

01/06/14 P. 16/16

AP 3253

<p>POUR MOTOR FOR MOTOR FOR ENGINE FOR DIESEL C21: J5 71001 C22: 298 433</p>	<p>SONDE DE PRESSION DRUCKSENSOR SENSOR DE PRESSION PRESSURE SENSOR SENSORE DI PRESSIONE</p>	<p>M 26-2/4 ST3B M 30-2/4 ST3B M 30-2/4H ST3B M 40-2/4 ST3B M 40-2/4H ST3B M 50-2/4 ST3B M 50-2/4H ST3B</p>
--	---	--

01/06/14 P. 16/16

AP 3254

<p>POUR MOTOR FOR MOTOR FOR ENGINE FOR DIESEL C21: J5 71001 C22: 298 433</p>	<p>THERMOSTAT THERMOSTAT THERMOSTATO THERMOSTAT THERMOSTATO</p>	<p>M 26-2/4 ST3B M 30-2/4 ST3B M 30-2/4H ST3B M 40-2/4 ST3B M 40-2/4H ST3B M 50-2/4 ST3B M 50-2/4H ST3B</p>
--	--	--

01/06/14 P. 16/16

AP 3255

<p>POUR MOTOR FOR MOTOR FOR ENGINE FOR DIESEL C21: J5 71001 C22: 298 433</p>	<p>COLLECTEUR D' ECHAPPEMENT AUSPUSKMANIFOLD COLLECTOR OF ESCAPE EXHAUST MANIFOLD COLLETORE DI SCARICO</p>	<p>M 26-2/4 ST3B M 30-2/4 ST3B M 30-2/4H ST3B M 40-2/4 ST3B M 40-2/4H ST3B M 50-2/4 ST3B M 50-2/4H ST3B</p>
--	---	--

01/06/14 P. 16/16

AP 3256

<p>POUR MOTOR FOR MOTOR FOR ENGINE FOR DIESEL C21: J5 71001 C22: 298 433</p>	<p>FILTRE A PARTICULES D' ECHAPPEMENT RABRINTELFILTER FILTRO DE PARTICULAS EXHAUST PARTICULATE FILTER FILTRA ANTPARTICULATO DI SCARICO</p>	<p>M 26-2/4 ST3B M 30-2/4 ST3B M 30-2/4H ST3B M 40-2/4 ST3B M 40-2/4H ST3B M 50-2/4 ST3B M 50-2/4H ST3B</p>
--	---	--

01/06/14 P. 16/16

AP 3257

<p>POUR MOTOR FOR MOTOR FOR ENGINE FOR DIESEL C21: J5 71001 C22: 298 433</p>	<p>COLLECTEUR D'ADMISSION ANSAUGLEITUNG COLLECTOR OF ADMISION INTAKE MANIFOLD COLLETORE DI AMMISSIONE</p>	<p>M 26-2/4 ST3B M 30-2/4 ST3B M 30-2/4H ST3B M 40-2/4 ST3B M 40-2/4H ST3B M 50-2/4 ST3B M 50-2/4H ST3B</p>
--	--	--

01/06/14 P. 16/16

AP 3258

<p>POUR MOTOR FOR MOTOR FOR ENGINE FOR DIESEL C21: J5 71001 C22: 298 433</p>	<p>MELANGEUR MISCHER MEZCLADOR MIXER MISCELATORE</p>	<p>M 26-2 ST3B M 30-2 ST3B M 30-4 ST3B M 40-2 ST3B M 40-4 ST3B M 50-2 ST3B M 50-4 ST3B</p>
--	---	---

01/06/14 P. 16/16



AP 3259

FOR MOTOR	ALTERNATEUR	M 26-2/4 ST3B	M 26-2/4H ST3B
FOR MOTOR	WECHSELSTROMGENERATOR	M 30-2/4 ST3B	M 30-2/4H ST3B
FOR ENGINE	ALTERNADOR	M 40-2/4 ST3B	M 40-2/4H ST3B
FOR ENGINE	ALTERNATOR	M 50-2/4 ST3B	M 50-2/4H ST3B

C1 par JS 71001
C2 par 298 433

01/06/14

AP 3260

FOR MOTOR	VOLANT-MOTEUR	M 26-2/4 ST3B	M 26-2/4H ST3B
FOR MOTOR	SCHWUNGLAD	M 30-2/4 ST3B	M 30-2/4H ST3B
FOR ENGINE	VOLANTE MOTOR	M 40-2/4 ST3B	M 40-2/4H ST3B
FOR ENGINE	FLYWHEEL	M 50-2/4 ST3B	M 50-2/4H ST3B

C1 par JS 71001
C2 par 298 433

01/06/14

AP 3261

FOR MOTOR	DEMARREUR	M 26-2/4 ST3B	M 26-2/4H ST3B
FOR MOTOR	ANLASER	M 30-2/4 ST3B	M 30-2/4H ST3B
FOR ENGINE	MOTOR DE ARRANQUE	M 40-2/4 ST3B	M 40-2/4H ST3B
FOR ENGINE	STARTER MOTOR	M 50-2/4 ST3B	M 50-2/4H ST3B

C1 par JS 71001
C2 par 298 433

MOTORING ADVANTAGE

01/06/14

AP 3262

FOR MOTOR	TURBO-COMPRESSEUR (Details)	M 26-2/4 ST3B	M 26-2/4H ST3B
FOR MOTOR	TURBOCOMPRESSOR (Einzelteile)	M 30-2/4 ST3B	M 30-2/4H ST3B
FOR ENGINE	TURBOCOMPRESSOR (Details)	M 40-2/4 ST3B	M 40-2/4H ST3B
FOR ENGINE	TURBOCHARGER (Details)	M 50-2/4 ST3B	M 50-2/4H ST3B

C1 par JS 71001
C2 par 298 433

TURBOCOMPRESORE (Dettaglio)

* LUBR. REC. DEP. 14
LUBRICANT REF. 14
LUBRICANTE CONSIG. 14
LUBRIFICACION CONSIG. 14
LUBRIFICAZIONE CONSIG. 14

01/06/14

AP 3263

FOR MOTOR	TURBO-COMPRESSEUR (Details)	M 26-2/4 ST3B	M 26-2/4H ST3B
FOR MOTOR	TURBOCOMPRESSOR (Einzelteile)	M 30-2/4 ST3B	M 30-2/4H ST3B
FOR ENGINE	TURBOCOMPRESSOR (Details)	M 40-2/4 ST3B	M 40-2/4H ST3B
FOR ENGINE	TURBOCHARGER (Details)	M 50-2/4 ST3B	M 50-2/4H ST3B

C1 par JS 71001
C2 par 298 433

TURBOCOMPRESORE (Dettaglio)

* LUBR. REC. DEP. 14
LUBRICANT REF. 14
LUBRICANTE CONSIG. 14
LUBRIFICACION CONSIG. 14
LUBRIFICAZIONE CONSIG. 14

01/06/14

AP 3264

FOR MOTOR	MODULE COMMANDE MOTEUR	M 26-2/4 ST3B	M 26-2/4H ST3B
FOR MOTOR	MOTORSTEUERUNG	M 30-2/4 ST3B	M 30-2/4H ST3B
FOR ENGINE	MOTOR DE LA UNIDAD DE CONTROL	M 40-2/4 ST3B	M 40-2/4H ST3B
FOR ENGINE	ENGINE CONTROL MODULE	M 50-2/4 ST3B	M 50-2/4H ST3B

C1 par JS 71001
C2 par 298 433

UNITA DI CONTROLLO MOTORE

01/06/14

AP 3265

FOR MOTOR	CIRCUIT COMBUSTIBLE	M 26-2/4 ST3B	M 26-2/4H ST3B
FOR MOTOR	BRENNSTOFFKREIS	M 30-2/4 ST3B	M 30-2/4H ST3B
FOR ENGINE	CIRCUITO COMBUSTIBLE	M 40-2/4 ST3B	M 40-2/4H ST3B
FOR ENGINE	FUEL CIRCUIT	M 50-2/4 ST3B	M 50-2/4H ST3B

C1 par JS 71001
C2 par 298 433

SYSTEMA NAPTA

01/06/14

AP 3266

FOR MOTOR	CIRCUIT COMBUSTIBLE	M 26-2/4 ST3B	M 26-2/4H ST3B
FOR MOTOR	BRENNSTOFFKREIS	M 30-2/4 ST3B	M 30-2/4H ST3B
FOR ENGINE	CIRCUITO COMBUSTIBLE	M 40-2/4 ST3B	M 40-2/4H ST3B
FOR ENGINE	FUEL CIRCUIT	M 50-2/4 ST3B	M 50-2/4H ST3B

C1 par JS 71001
C2 par 298 433

SYSTEMA NAPTA

01/06/14

AP 3267

FOR MOTOR	CIRCUIT COMBUSTIBLE	M 26-2/4 ST3B	M 26-2/4H ST3B
FOR MOTOR	BRENNSTOFFKREIS	M 30-2/4 ST3B	M 30-2/4H ST3B
FOR ENGINE	CIRCUITO COMBUSTIBLE	M 40-2/4 ST3B	M 40-2/4H ST3B
FOR ENGINE	FUEL CIRCUIT	M 50-2/4 ST3B	M 50-2/4H ST3B

C1 par JS 71001
C2 par 298 433

SYSTEMA NAPTA

01/06/14



AP 3268	POUR MOTOR FOR MOTOR FOR MOTOR FOR MOTOR	FILTRE A HUILE ÖLFILTER FILTRO DE ACEITE OIL FILTER FILTRO OLEO	M 26-2/4 ST3B	M 26-2/4H ST3B
	C1= JS 71001		M 30-2/4 ST3B	M 30-2/4H ST3B
	C2= 264 389		M 40-2/4 ST3B	M 40-2/4H ST3B
			M 50-2/4 ST3B	M 50-2/4H ST3B

01/06/14

AP 3269	POUR MOTOR FOR MOTOR FOR MOTOR FOR MOTOR	BRIDE D'ADAPTATION ANPASSUNG BRICA FLANGIA ADAPTACION ADAPTACION FLANGE FLANGIA ADATTAMENTO	M 26-2/4 ST3B	M 26-2/4H ST3B
	C1= JS 71001		M 30-2/4 ST3B	M 30-2/4H ST3B
	C2= 264 389		M 40-2/4 ST3B	M 40-2/4H ST3B
			M 50-2/4 ST3B	M 50-2/4H ST3B

01/06/14

BOITE DE VITESSES - GETRIEBEKASTEN CAJA DE VELOCIDADES - GEAR BOX CAMBIO

TYPE - TYPEN TIPO - TYPE TIPO	16564
REFERENCE - NUMBER NUMERO - NUMBER RIFERIMENTO	264 389

BP 8065	POUR MOTOR FOR MOTOR FOR MOTOR FOR MOTOR	BOITE DE VITESSES ET CONVERTISSEUR GETRIEBEKASTEN UND WÄRMERHEBER CAJA DE VELOCIDADES Y CONVERTIDOR GEAR BOX AND CONVERTER CAMBIO E CONVERTITORE	M 26-2 ST3B	M 26-2H ST3B
	C1= 16564		M 30-2 ST3B	M 30-2H ST3B
	C2= 264 389		M 40-2 ST3B	M 40-2H ST3B
			M 50-2 ST3B	M 50-2H ST3B

01/06/14

BP 256	POUR MOTOR FOR MOTOR FOR MOTOR FOR MOTOR	BOITE DE VITESSES (Detail) GETRIEBEKASTEN (Detail) CAJA DE VELOCIDADES (Detail) GEAR BOX (Detail) CAMBIO (Detail)	M 26-2 ST3B	M 26-2H ST3B
	C1= 16564		M 30-2 ST3B	M 30-2H ST3B
	C2= 264 389		M 40-2 ST3B	M 40-2H ST3B
			M 50-2 ST3B	M 50-2H ST3B

01/06/14

BP 257	POUR BOITE DE VITESSES FOR GEAR BOX FOR GEAR BOX FOR GEAR BOX	BOITE DE VITESSES (Detail) mécanismes - Pignonnerie GETRIEBEKASTEN (Mechanismus einbaueile - Zahnräder) CAJA DE VELOCIDADES (Detail) mecanismos - Pines	M 26-2 ST3B	M 26-2H ST3B
	C1= 16564		M 30-2 ST3B	M 30-2H ST3B
	C2= 264 389		M 40-2 ST3B	M 40-2H ST3B
			M 50-2 ST3B	M 50-2H ST3B

01/06/14

BP 203	POUR MOTOR FOR MOTOR FOR MOTOR FOR MOTOR	VALVE DE CONTROLÉ ELECTRIQUE ELEKTRISCHE KONTROLLVENTILE VALVULA DE CONTROL ELECTRICA ELECTRICAL CONTROL VALVE VALVOLA DI CONTROLLO ELETTRICO	M 26-2 ST3B	M 26-2H ST3B
	C1= 15984		M 30-2 ST3B	M 30-2H ST3B
	C2= 16025		M 40-2 ST3B	M 40-2H ST3B
	C3= 16024		M 50-2 ST3B	M 50-2H ST3B

01/06/14

BOITE DE VITESSES - GETRIEBEKASTEN
CAJA DE VELOCIDADES - GEAR BOX
CAMBIO - VERSNELLINGSBAK - VAIHDELAATIKKO

TYPE - TYPEN
 TIPO - TYPE
 TIPO - TYPE - TYYPPI | **16568**

REFERENCE - NUMMER
 NUMERO - NUMBER
 RIFERIMENTO - NUMMER - NUMERO | **264 390**

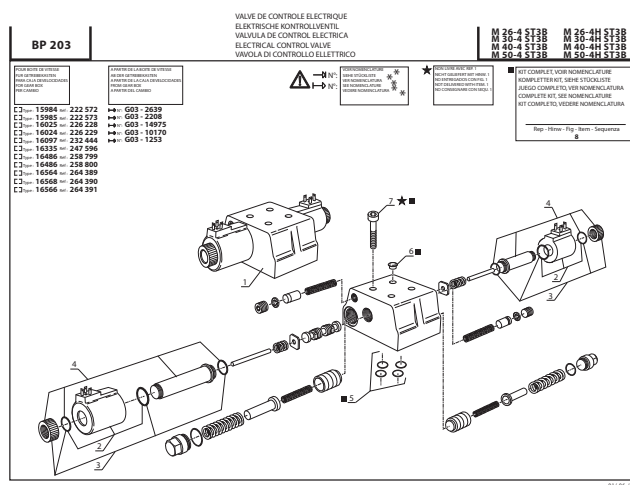
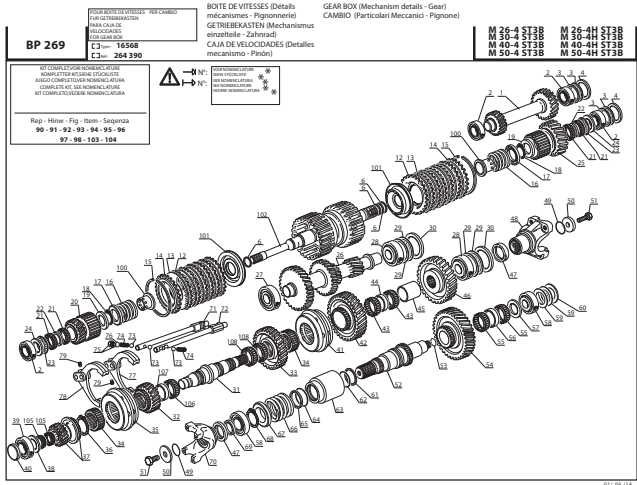
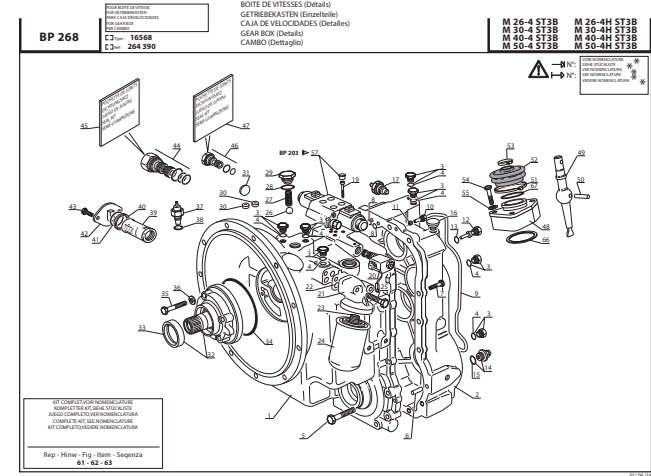
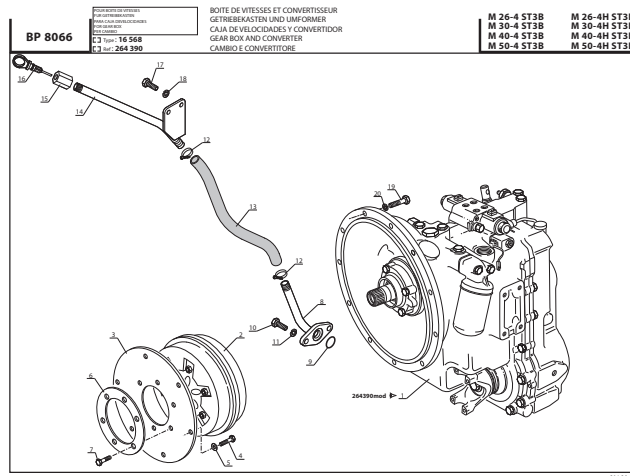

CARDAN DE TRANSMISSION BOITE - ESSIEU ARRIERE
KARDANKUPPLUNG GETRIEBKASTEN - HINTERACHSE
CARDAN DE TRANSMISION CAJA - EJE TRASERO
CARDAN COUPLING GEAR BOX - REAR AXLE
CARDANO DI TRASMISSIONE CAMBIO - PONTE POSTERIORE

295 114

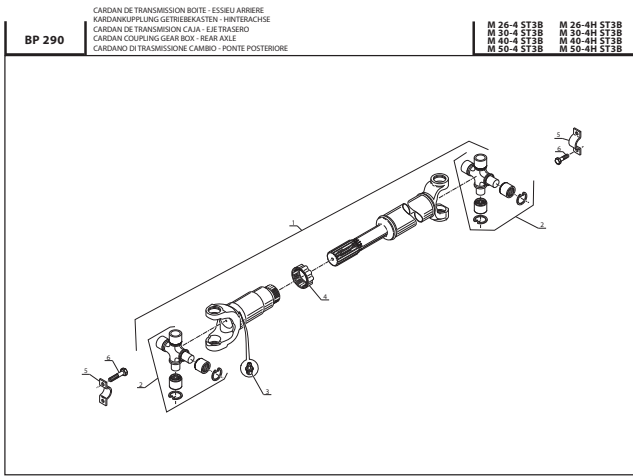

CARDAN DE TRANSMISSION BOITE - ESSIEU AVANT
KARDANKUPPLUNG GETRIEBKASTEN - VORNACHSE
CARDAN DE TRANSMISION CAJA - EJE DELANTERO
CARDAN COUPLING GEAR BOX - FRONT AXLE
CARDANO DI TRASMISSIONE CAMBIO - ASSALE ANTERIORE

295 117

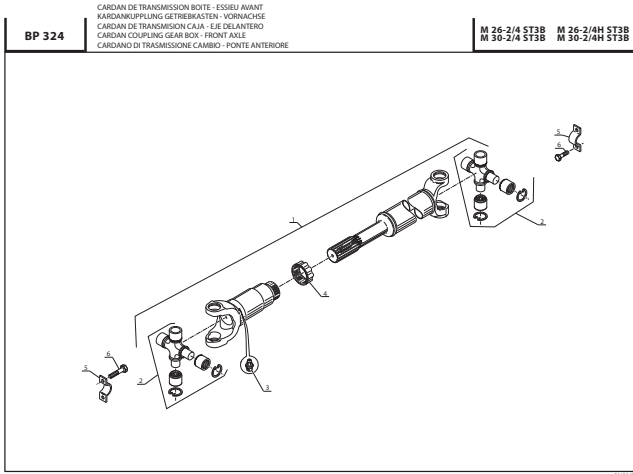

CARDAN DE TRANSMISSION BOITE - ESSIEU AVANT
KARDANKUPPLUNG GETRIEBKASTEN - VORNACHSE
CARDAN DE TRANSMISION CAJA - EJE DELANTERO
CARDAN COUPLING GEAR BOX - FRONT AXLE
CARDANO DI TRASMISSIONE CAMBIO - PONTE ANTERIORE

301500

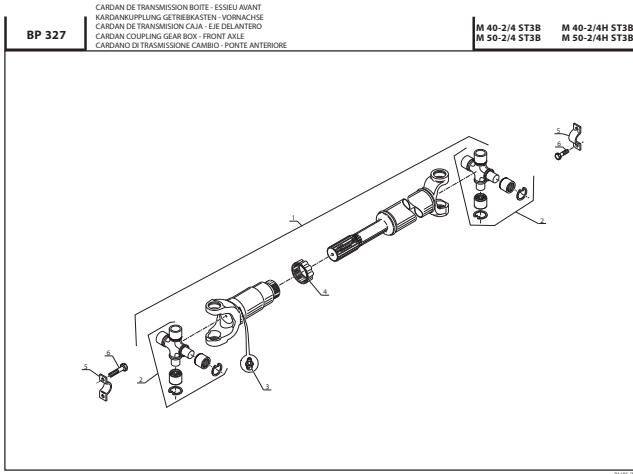

**ESSEU AVANT - VORNACHSE
EJE DELANTERO - FRONT AXLE
ASSALE ANTERIORE**

TYPE - TYPEN
TIPO - TYPE
TIPO

112 / 203

REFERENCE - NUMBER
NUMERO - NUMBER
RIFERIMENTO

302 510

AX 8069	FOR FRONT AXLE FOR VORNACHSE FOR FRONT AXLE FOR FRONT AXLE C3 Typ: 112 / 203 C3 Ref: 302 510	ESSEU AVANT VORNACHSE EJE DELANTERO FRONT AXLE PONTE ANTERIORE	M 26-2 ST3B M 30-2 ST3B M 40-2 ST3B M 50-2 ST3B	M 26-2H ST3B M 30-2H ST3B M 40-2H ST3B M 50-2H ST3B
---------	---	--	--	--

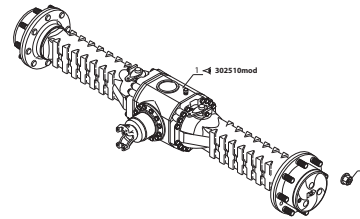

AX 2117	FOR DISC BRAKE FOR VORNACHSE FOR FRONT AXLE FOR FRONT AXLE C3 Typ: 112 / 203 C3 Ref: 302 510	CARTER ESSEU AVANT VORNACHSE GEHÄUSE CARTER EJE DELANTERO FRONT AXLE CASING CARTER ASSALE ANTERIORE	M 26-2 ST3B M 30-2 ST3B M 40-2 ST3B M 50-2 ST3B	M 26-2H ST3B M 30-2H ST3B M 40-2H ST3B M 50-2H ST3B
---------	---	---	--	--

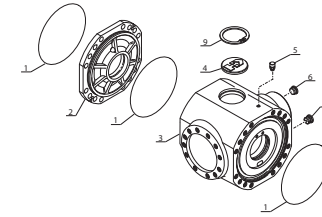

AX 2118	FOR DIFFERENTIAL FOR VORNACHSE FOR FRONT AXLE FOR FRONT AXLE C3 Typ: 112 / 203 C3 Ref: 302 510	DIFFERENTIEL ESSEU AVANT VORNACHSE DIFFERENTIAL FRONT AXLE DIFFERENTIAL DIFFERENZIALE ASSALE ANTERIORE	M 26-2 ST3B M 30-2 ST3B M 40-2 ST3B M 50-2 ST3B	M 26-2H ST3B M 30-2H ST3B M 40-2H ST3B M 50-2H ST3B
---------	---	---	--	--

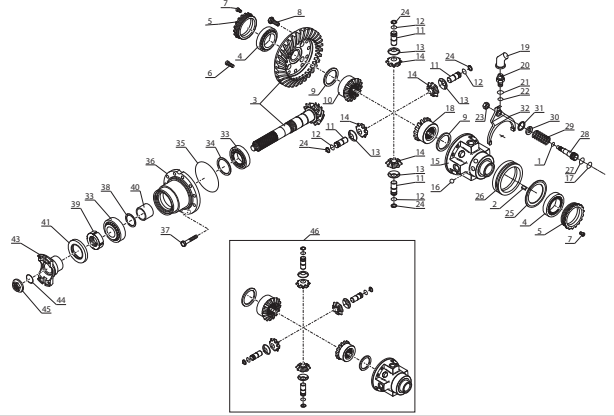

AX 2119	FOR REDUCTION GEAR FOR VORNACHSE FOR FRONT AXLE FOR FRONT AXLE C3 Typ: 112 / 203 C3 Ref: 302 510	REDUCTEUR ESSEU AVANT VORNACHSE REDUKTIONSGETRIEBE REDUCTOR EJE DELANTERO FRONT AXLE REDUCTION GEAR RIDUZIONE EPICICLODALE ASSALE ANTERIORE	M 26-2 ST3B M 30-2 ST3B M 40-2 ST3B M 50-2 ST3B	M 26-2H ST3B M 30-2H ST3B M 40-2H ST3B M 50-2H ST3B
---------	---	---	--	--

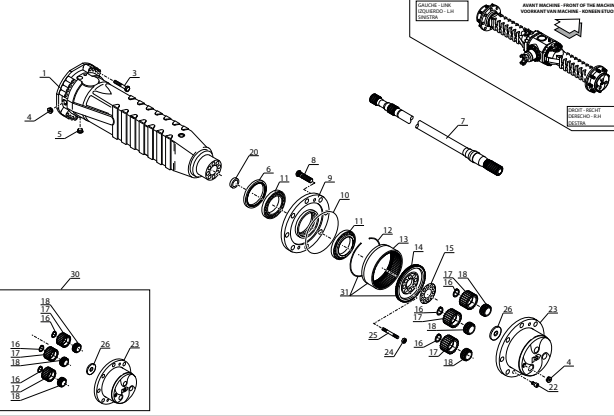

AX 2120	FOR DISC BRAKE FOR VORNACHSE FOR FRONT AXLE FOR FRONT AXLE C3 Typ: 112 / 203 C3 Ref: 302 510	FREIN A DISQUE A BAIN D' HUILE - ESSEU AVANT ÖLBADESCHEIBENBREMS - VORNACHSE FRENO DE DISCO A BANO DE ACEITE - EJE DELANTERO OIL BATH DISC BRAKE - FRONT AXLE FRENO A DISCO IN BAGNO D'OLIO ASSALE ANTERIORE	M 26-2 ST3B M 30-2 ST3B M 40-2 ST3B M 50-2 ST3B	M 26-2H ST3B M 30-2H ST3B M 40-2H ST3B M 50-2H ST3B
---------	---	--	--	--

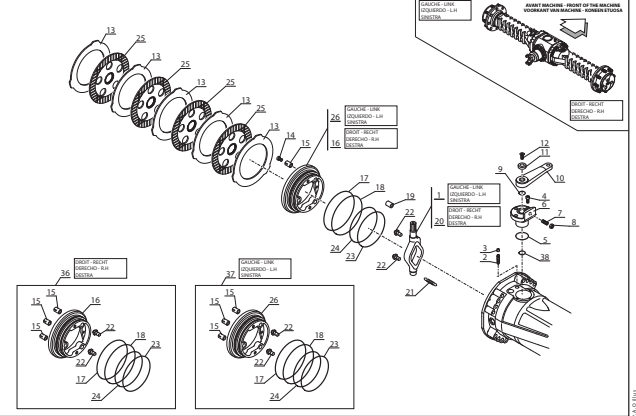

ESSIEU AVANT - VORNACHSE
EJE DELANTERO - FRONT AXLE
ASSALE ANTERIORE

TYPE - TYPEN
TIPO - TYPE
TIPO

212 / 204

REFERENCE - NUMBER
NUMERO - NUMBER
RIFERIMENTO

302 511

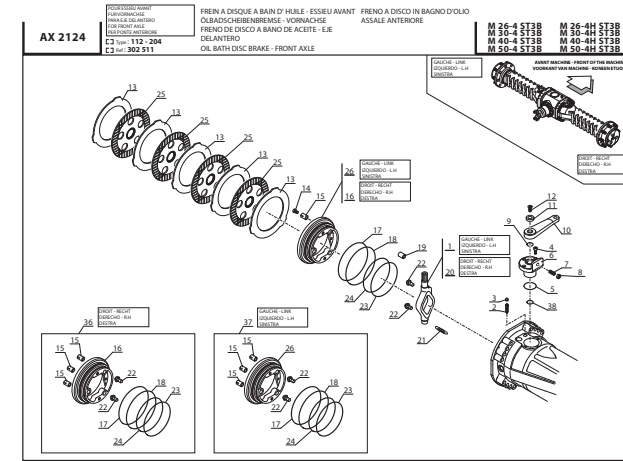
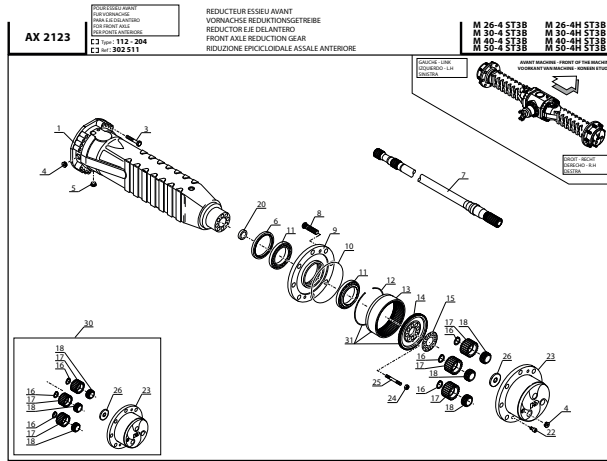
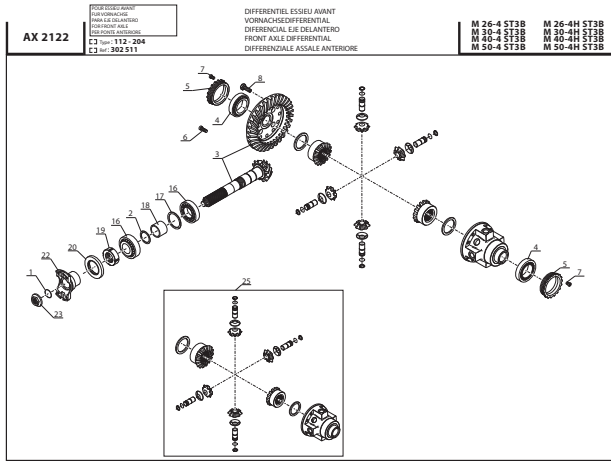
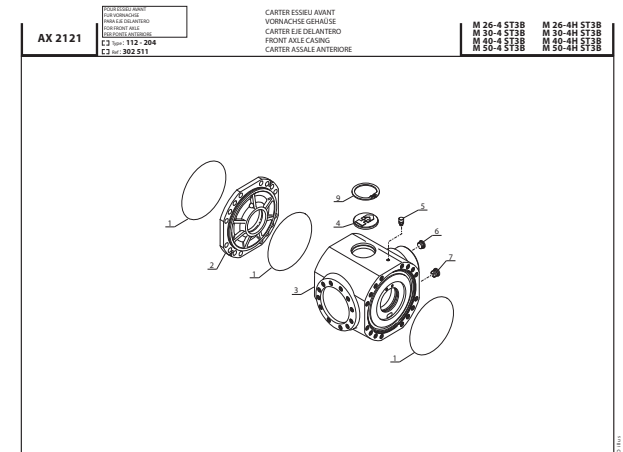
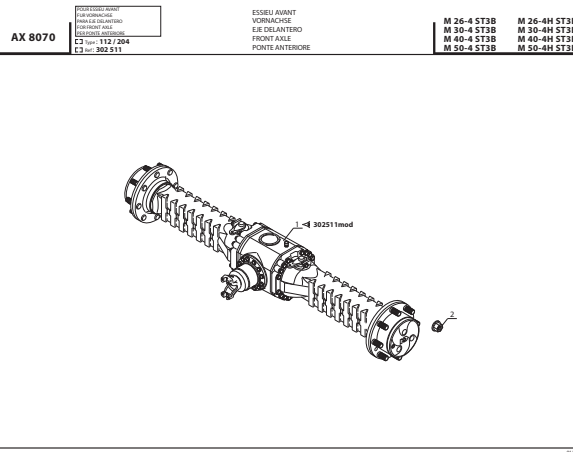

ESSIEU ARRIERE - HINTERACHSE

EJE TRASERO - REAR AXLE

PONTE POSTERIORE

TYPE - TYPEN
TIPO - TYPE
TIPO

211 / 137

REFERENCE - NUMMER
NUMERO - NUMBER
RIFERIMENTO

289 504

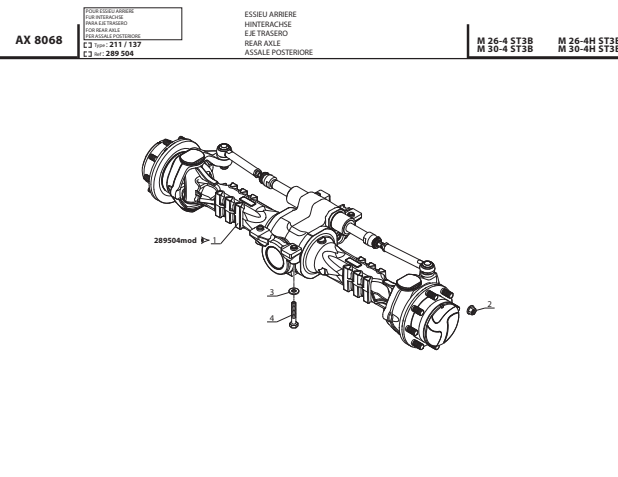

01/06/14

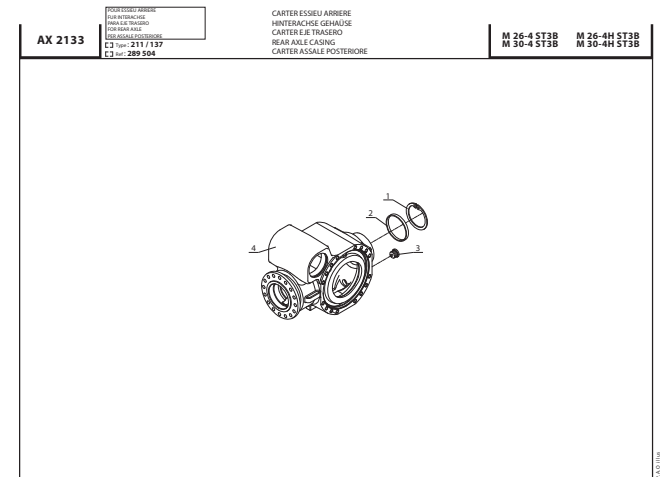

01/06/14

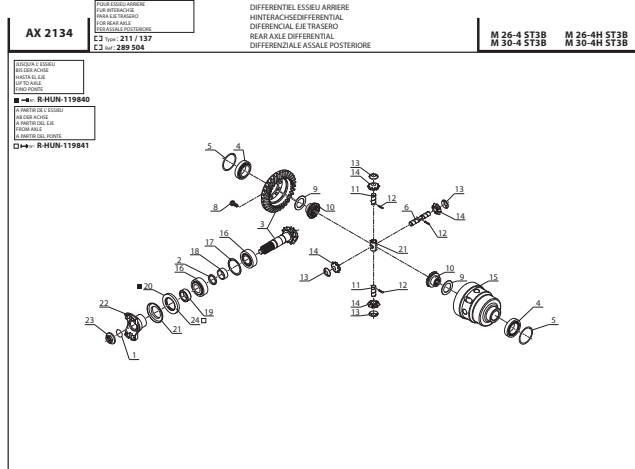

01/06/14

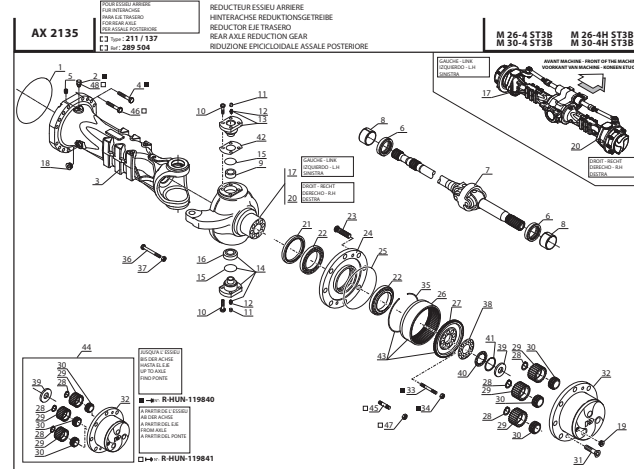

01/06/14

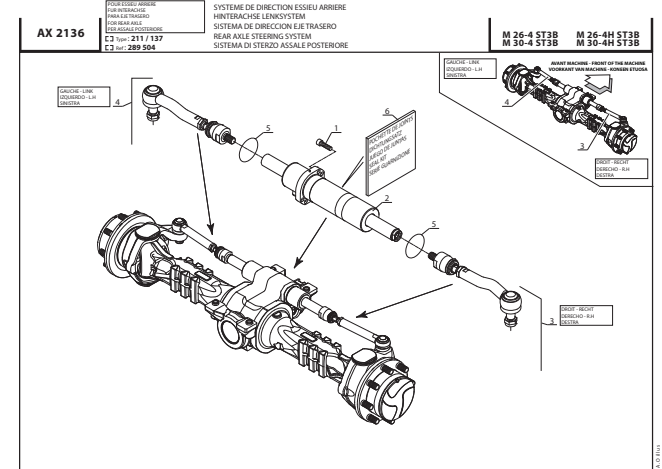

01/06/14

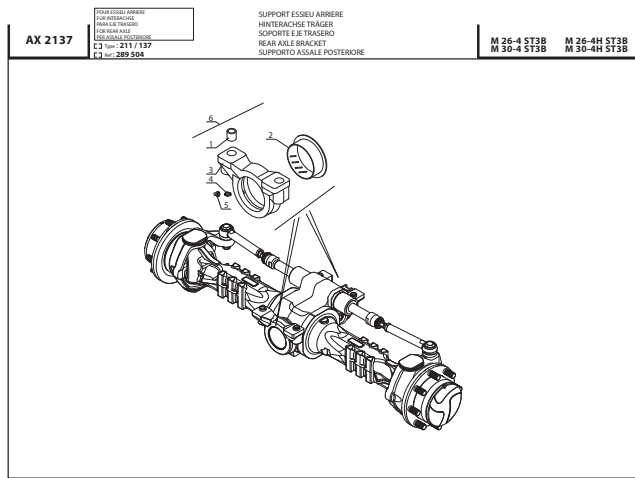

01/06/14



ESSIEU ARRIERE - HINTERACHSE

EJE TRASERO - REAR AXLE

PONTE POSTERIORE

TYPE - TYPEN
TIPO - TYPE
TIPO

212 / 493

REFERENCE - NUMMER
NUMERO - NUMBER
RIFERIMENTO

247 290

AX 8067

POUR LES TYPES
DES MACHINES
M 40-4 ST3B
M 50-4 ST3B
C3 Typ: 212 / 493
C3 Ser: 247 290

ESSIEU ARRIERE
HINTERACHSE
EJE TRASERO
ASSALE POSTERIORE

M 40-4 ST3B M 40-4H ST3B
M 50-4 ST3B M 50-4H ST3B

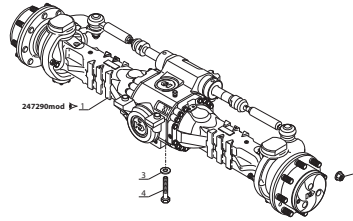

AX 1585

POUR LES TYPES
DES MACHINES
M 40-4 ST3B
M 50-4 ST3B
C3 Typ: 212 / 493
C3 Ser: 247 290

CARTER ESSIEU ARRIERE
HINTERACHSE GEHÄUSE
CARTER EJE TRASERO
CARTER ASSALE POSTERIORE

M 40-4 ST3B M 40-4H ST3B
M 50-4 ST3B M 50-4H ST3B

POUR LES TYPES
DES MACHINES
M 40-4 ST3B
M 50-4 ST3B
C3 Typ: 212 / 493
C3 Ser: 247 290

POUR LES TYPES
DES MACHINES
M 40-4 ST3B
M 50-4 ST3B
C3 Typ: 212 / 493
C3 Ser: 247 290

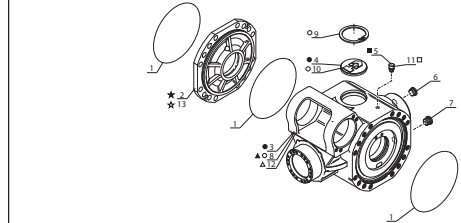

AX 1586

POUR LES TYPES
DES MACHINES
M 40-4 ST3B
M 50-4 ST3B
C3 Typ: 212 / 493
C3 Ser: 247 290

DIFFÉRENTIEL ESSIEU ARRIERE
HINTERACHSE DIFFERENTIAL
DIFERENCIAL EJE TRASERO
REAR AXLE DIFFERENTIAL
DIFFERENZIALE ASSALE POSTERIORE

M 40-4 ST3B M 40-4H ST3B
M 50-4 ST3B M 50-4H ST3B

POUR LES TYPES
DES MACHINES
M 40-4 ST3B
M 50-4 ST3B
C3 Typ: 212 / 493
C3 Ser: 247 290

POUR LES TYPES
DES MACHINES
M 40-4 ST3B
M 50-4 ST3B
C3 Typ: 212 / 493
C3 Ser: 247 290

● → K.ITA.721 160
■ → G.ITA.706 924
▲ → L.ITA.719 782
◆ → K.ITA.727 146
★ → K.ITA.759 671

○ → G.ITA.721 161
□ → G.ITA.706 925
△ → L.ITA.719 783
◇ → K.ITA.727 147
★ → K.ITA.759 672

AX 1587

POUR LES TYPES
DES MACHINES
M 40-4 ST3B
M 50-4 ST3B
C3 Typ: 212 / 493
C3 Ser: 247 290

REDUCTEUR ESSIEU ARRIERE
HINTERACHSE REDUKTIONSGEHTRIEBE
REDUCTOR EJE TRASERO
REAR AXLE REDUCTION GEAR
REDUZIONE EPICICLODALE ASSALE POSTERIORE

M 40-4 ST3B M 40-4H ST3B
M 50-4 ST3B M 50-4H ST3B

POUR LES TYPES
DES MACHINES
M 40-4 ST3B
M 50-4 ST3B
C3 Typ: 212 / 493
C3 Ser: 247 290

POUR LES TYPES
DES MACHINES
M 40-4 ST3B
M 50-4 ST3B
C3 Typ: 212 / 493
C3 Ser: 247 290

● → F.ITA.725 683
■ → G.ITA.722 660
▲ → K.ITA.781 065
◆ → M.ITA.706 460
★ → M.ITA.730 319

○ → F.ITA.729 683
□ → G.ITA.722 661
△ → K.ITA.781 066
◇ → M.ITA.706 461
★ → M.ITA.730 320

AX 1588

POUR LES TYPES
DES MACHINES
M 40-4 ST3B
M 50-4 ST3B
C3 Typ: 212 / 493
C3 Ser: 247 290

SYSTEME DE DIRECTION ESSIEU ARRIERE
HINTERACHSE LENKSTERN
SISTEMA DE DIRECCION EJE TRASERO
REAR AXLE STEERING SYSTEM
SISTEMA DI STERZO ASSALE POSTERIORE

M 40-4 ST3B M 40-4H ST3B
M 50-4 ST3B M 50-4H ST3B

POUR LES TYPES
DES MACHINES
M 40-4 ST3B
M 50-4 ST3B
C3 Typ: 212 / 493
C3 Ser: 247 290

POUR LES TYPES
DES MACHINES
M 40-4 ST3B
M 50-4 ST3B
C3 Typ: 212 / 493
C3 Ser: 247 290

● → K.ITA.757 396
■ → P.ITA.709 627

○ → K.ITA.757 397
□ → P.ITA.709 628

AX 1589

POUR LES TYPES
DES MACHINES
M 40-4 ST3B
M 50-4 ST3B
C3 Typ: 212 / 493
C3 Ser: 247 290

SUPPORT ESSIEU ARRIERE
HINTERACHSE TRÄGER
SOPORTE EJE TRASERO
REAR AXLE BRACKET
SUPPORTO ASSALE POSTERIORE

M 40-4 ST3B M 40-4H ST3B
M 50-4 ST3B M 50-4H ST3B



2 AA 8000

FILTRES ET COURROIES
FILTER UND KEILRIEMENS
FILTROS Y CORREAS
FILTERS AND BELTS
FILTROS E CINGHIA

M 26-2/4 ST3B M 26-2/4H ST3B
M 30-2/4 ST3B M 30-2/4H ST3B
M 40-2/4 ST3B M 40-2/4H ST3B
M 50-2/4 ST3B M 50-2/4H ST3B

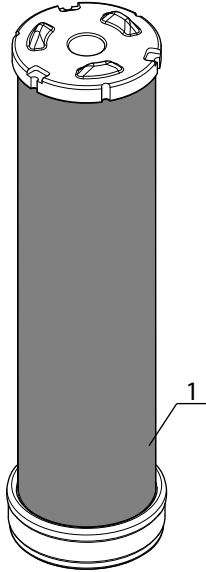

CARTOUCHE SECURITE FILTRE A AIR
SICHERHEIT LUFTFILTEREINSATZ
CARTUCHO SEGURIDAD FILTRO DE AIRE
SECURITY AIR FILTER CARTRIDGE
CARTUCCIA DI SICUREZZA FILTRO ARIA

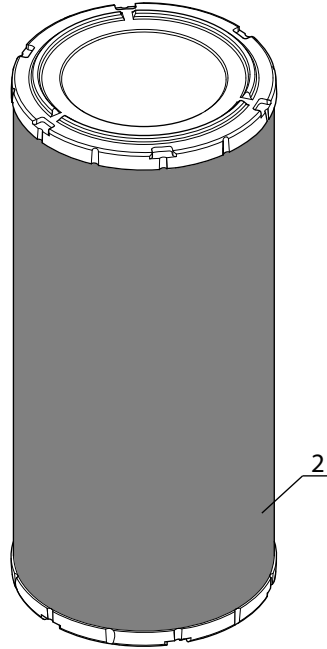

CARTOUCHE FILTRE A AIR
LUFTFILTEREINSATZ
CARTUCHO FILTRO DE AIRE
AIR FILTER CARTRIDGE
CARTUCCIA FILTRO ARIA

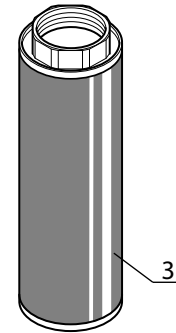

CREPINE DU CIRCUIT PRINCIPAL
SEIHER HAUPTKREIS
FILTRO DE PASO DE CIRCUITO PRINCIPAL
PRINCIPAL CIRCUIT STRAINER
PIGNA DE SERBATOIO OLIO
FILTER HOOFDLEIDINGSYSTEEM
PÄÄPIIRIN SIHTI

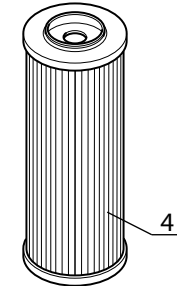

CARTOUCHE FILTRE A HUILE RETOUR HYDRAULIQUE
PATRONE HYDRAULIK RUCKGANG OLFILTER
CARTUCHO FILTRO ACEITE RETORNO HIDRAULICO
CARTRIDGE HYDRAULIC RETURN OIL FILTER
CARTUCCIA FILTRO OLIO RITORNO IDRAULICO

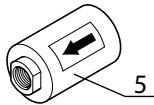

FILTRE A HUILE
OL FILTER
FILTRO ACEITE
OIL FILTER
FILTRO OLIO

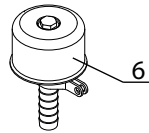

RENIFLARD BAC A HUILE
ENLUFUNG OLBEHÄLTER
RESPIRADERO TANQUE DE ACEITE
OIL TANK AIR BREATHER
SFIATO SERBATOIO OLIO

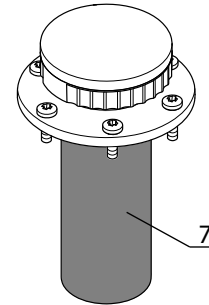

BOUCHON DE REMPLISSAGE COMPLET
KOMPLETTER EINFÜLLVERSCHLUSS
TAPON DE LLENADO COMPLETO
COMPLETE FILLING PLUG
TAPPO DI RIEMPIMENTO COMPLETO

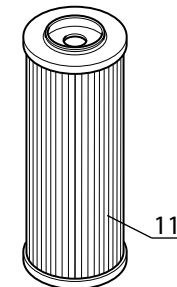

CARTOUCHE FILTRE HYDROSTATIC
PATRONE HYDROSTATIK OLFILTER
CARTUCHO FILTRO HIDROSTATICO
CARTRIDGE FILTER HYDROSTATIC
CARTUCCIA FILTRO IDROSTATICO

Catalogue : 647483

1	FILTRES ET COURROIES FILTER UND KEILRIEMENS FILTROS Y CORREAS FILTERS AND BELTS FILTROS E CINGHIA			Qte-Menge-Cant-Qty-Q.ta-										2 AA 8000									
	Rep Hinw Fig Item Rif	Numéro Teil-Nr Numero Part-Nr Part-Nr	Désignation Bezeichnung Descripcion Description Descrizione	1	2	3	4	5	6	7	8	9	10	11	12	13	14	15	16	17	18	19	20
1	490495	Cartouche sécurité filtre à air Cartucho seguridad filtro de aire Cartuccia di sicurezza filtro aria	-Sicherheit luftfiltereinsatz -Security air filter cartridge	1	1	1	1	1	1	1	1	1	1	1	1	1	1	1	1				
3	490494	Cartouche filtre à air filtro de aire Cartuccia filtro aria	-Luftfiltereinsatz -Air filter cartridge	1	1	1	1	1	1	1	1	1	1	1	1	1	1	1	1				
4	77402	Crépine du circuit principal Filtro de paso de circuito principal Pigna circuito principale	-Seiher hauptkreis -Principal circuit strainer	1	1	1	1	1	1	1	1	1	1	1	1	1	1	1	1				
5	221174	Cartouche filtre à huile retour hyd. Cartucho filtro aceite retorno hid. Cartuccia filtro olio ritorno idr.	-Patrone hyd. ruckgang olfil. -Cartridge hyd. ret oil filter	1	1	1	1	1	1	1	1	1	1	1	1	1	1	1	1				
6	254582	Filtre Filtro Filtro	-Filter -Filter	1	1	1	1	1	1	1	1	1	1	1	1	1	1	1	1				
7	278288	Reniflard bac à huile Respiradero tanque de aceite Sfiato serbatoio olio	-Enluftung olbehälter -Oil tank air breather	1	1	1	1	1	1	1	1	1	1	1	1	1	1	1	1				
8	259499	Bouchon de remplissage complet Tapón de llenado completo Tappo di riempimento completo	-Kompletter Einfüllverschluss -Complete Filling plug	1	1	1	1	1	1	1	1	1	1	1	1	1	1	1	1				
9	797755	Préfiltre à combustible combustible combustible	-Brennstovorfilter -Fuel pre-filter	1	1	1	1	1	1	1	1	1	1	1	1	1	1	1	1				
10	296854	filtre à combustible combustible combustible	-Brennstovorfilter -Fuel filter	1	1	1	1	1	1	1	1	1	1	1	1	1	1	1	1				
11	51300969	Cartouche filtre retour hydrostatique Cartucho filtro retorno idrostaico Cartuccia filtro olio ritorno idr.	-Patrone hyd. ruckgang olfil. -Cartridge hydrost ret filter										1	1	1	1	1	1	1				

M

3 AA 8001

ROUES AVANT
VORN RAD
RUEDAS DELETERA
FRONT WHEELS
ANTERIORE RUOTE

M 26-2/4 ST3B	M 26-2/4H ST3B
M 30-2/4 ST3B	M 30-2/4H ST3B
M 40-2/4 ST3B	M 40-2/4H ST3B
M 50-2/4 ST3B	M 50-2/4H ST3B

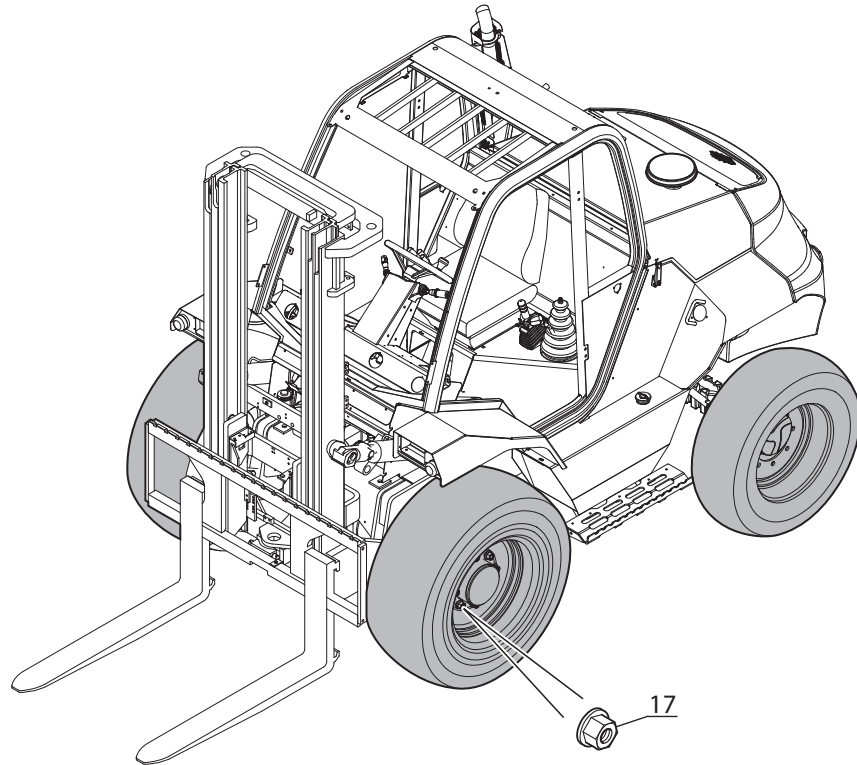

CONTINENTAL

14,5 R 20 18PR MPT 80 TL

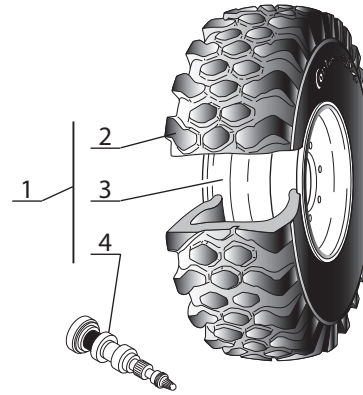

M 30-2 ST3B

DUNLOP

400/70-20 150B T37 STAB 150B TL

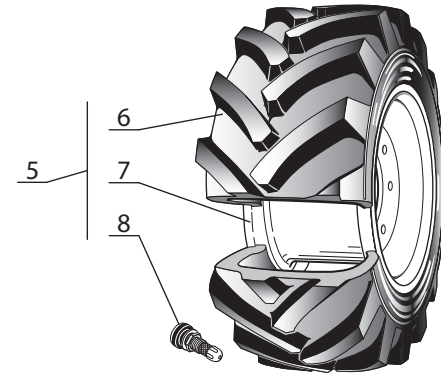

M 30-4 ST3B

EVEREST

18X19,5 18PR 8T P30 TUB

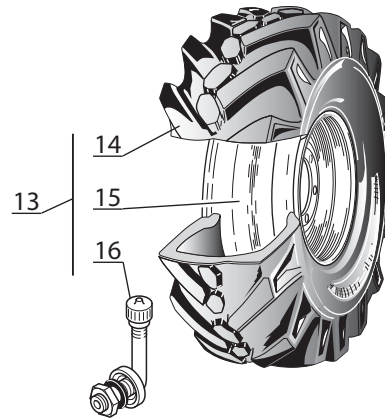

M 50-2 ST3B

MITAS

18-22,5 163 A8 MPT 06 TL

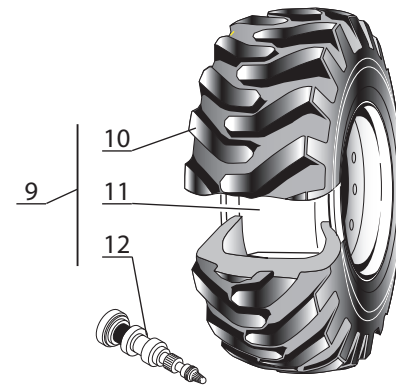

M 50-4 ST3B

Catalogue : 647483

1	ROUES AVANT VORN RAD RUEDAS DELENTERA FRONT WHEELS ANTERIORE RUOTE			Qte-Menge-Cant-Qty-Q.ta										3 AA 8001									
	Rep Hinw Fig Item Rif	Numéro Teil-Nr Numero Part-Nr Part-Nr	Désignation Bezeichnung Descripcion Description Descrizione	1	2	3	4	5	6	7	8	9	10	11	12	13	14	15	16	17	18	19	20
1	247299	Roue avant complète completa completa	-Komplett vorn rad -Complete front wheel -Rueda delantera -Ruota anteriore	2		2							2		2								
2	184305	Enveloppe 14.5R20 18PR MPT80 TUB CONTINENTAL Reifen Pneumatico	- Neumático - Tyre	1		1							1		1								
3	247298	Roue,nue 11x208T P55D23/275 Wheel, stripped	-Rad, allein -Ruota, nudo	1		1							1		1								
4	60665	Valve Válvula	- Ventil -Valvola	1		1							1		1								
5	303443	Roue avant complète completa completa	-Komplett vorn rad -Complete front wheel -Rueda delantera -Ruota anteriore			2		2					2		2								
6	184589	Enveloppe 400/70-20 T37 TL 150B DUNLOP Neumático	-Reifen -Pneumatico			1		1					1		1								
7	301986	Roue, nue13x208T P70D23/275 -Wheel, stripped	-Scheibenrad -Ruota, nudo			1		1					1		1								
8	60665	Valve Valve	-Ventil -Valvol			1		1					1		1								
9	255556	Roue avant complète completa completa	-Komplett vorn rad -Complete front wheel -Rueda delantera -Ruota anteriore							2		2					2				2		
10	255557	Enveloppe 18-22.5 163A8 MPT-06 TL MITAS Neumático	-Reifen -Pneumatico							1		1					1				1		
11	247300	Roue, nue 22,5 x1400 Rueda, sola	8T P20 D23/275 -Wheel, stripped -Ruota, nudo							1		1					1				1		
12	60665	Valve Válvula Venttiili	-Ventil -Valvola							1		1					1				1		

M

+

Catalogue : 647483

Rep Hinw Fig Item Rif	Numéro Teil-Nr Numero Part-Nr Part-Nr	Désignation Bezeichnung Descripcion Description Descrizione	Qte-Menge-Cant-Qty-Q.ta										3 AA 8001									
			1	2	3	4	5	6	7	8	9	10	11	12	13	14	15	16	17	18	19	20
2		CARROSSERIE KAROSSERIE CARROCERIA BODY CARROZZERIA																				
13	247318	Roue avant complète completa complet	-Komplett vorn rad -Complete front wheel	-Rueda delantera -Ruota anteriore																		
14	178956	Enveloppe 18x19.5 18PB Tire	-Reifen -Pneumatico	-Neumático																		
15	247302	Roue, nue 19,5 x1400 Rueda, sola	8T P30 D23/275 -Wheel, stripped	-Rad, allein -Ruota, nudo																		
16	202578	Valve Valve	-Ventil -Valvola	-Válvula																		
17	245767	Ecrou de roue Wheel nut	-Radmutter -Dado ruote	-Tuerca de rueda	16	16	16	16	16	16	16	16	16	16	16	16	16	16	16	16	16	

M

3 AA 8002

ROUES ARRIERE
HINTER RAD
RUEDAS TRASERA
REAR WHEELS
RUOTE POSTERIORE

M 26-2/4 ST3B	M 26-2/4H ST3B
M 30-2/4 ST3B	M 30-2/4H ST3B
M 40-2/4 ST3B	M 40-2/4H ST3B
M 50-2/4 ST3B	M 50-2/4H ST3B

GOOD YEAR

10R 17,5 134/132M G291 GY

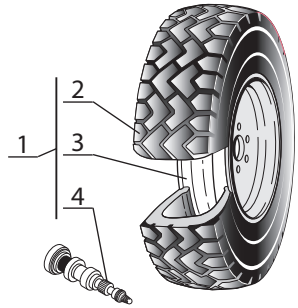

M 26/30-2 ST3B

DUNLOP

10,5/80-18 10PR TG 42 TL

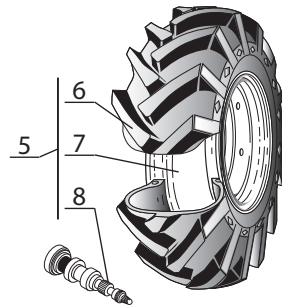

M 26/30-4 ST3B

GOOD YEAR

10R 17,5 134/132M G291 GY

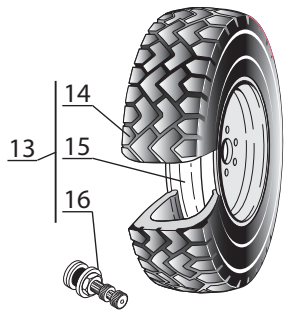

M 40/50-2 ST3B

MICHELIN

340/80R18 XMCL 143A8

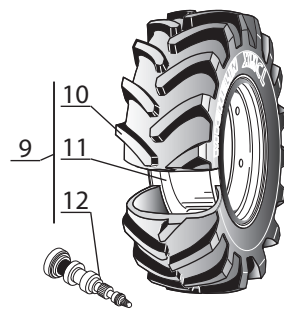

M 40/50-4 ST3B

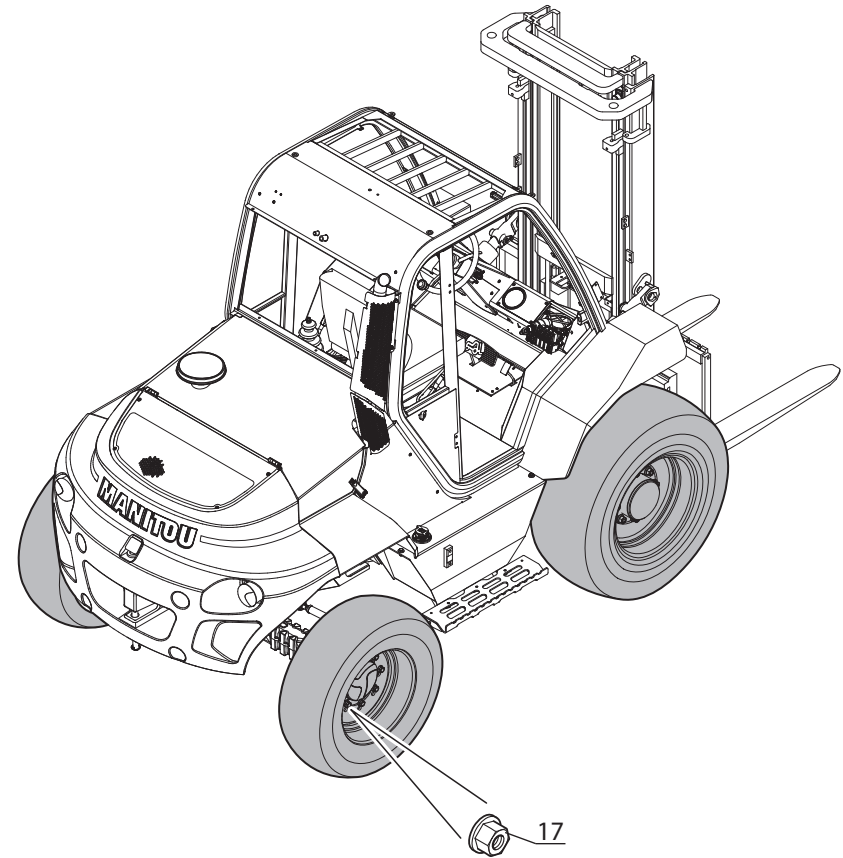

Catalogue : 647483

1	ROUES ARRIERE HINTER RAD RUEDAS TRASERA REAR WHEELS RUOTE POSTERIORE			Qte-Menge-Cant-Qty-Q.ta										3 AA 8002									
	Rep Hinw Fig Item Rif	Numéro Teil-Nr Numero Part-Nr Part-Nr	Désignation Bezeichnung Descripcion Description Descrizione	1	2	3	4	5	6	7	8	9	10	11	12	13	14	15	16	17	18	19	20
1	256868	Roue arrière complète completa completa	-Komplett hinter rad -Complete rear wheel -Rueda trasera -Ruota posteriore	2		2						2		2									
2	207130	Enveloppe 10R17.5 134M G291 GOODYEAR Tire	-Reifen -Pneumatico	1		1						1		1									
3	256869	Roue, nue 6,75x17,5 6T P 8 D19/205 Wheel, stripped	-Scheibenrad -Ruota, nudo	1		1						1		1									
4	60665	Valve Válvula	-Ventil -Valvola	1		1						1		1									
5	247309	Roue arrière complète trasera completa posteriore completa	-Komplett hinter rad -Complete rear wheel -Rueda -Ruota		2		2						2		2								
6	238095	Enveloppe 10.5x18 10PR MPT TG42 TL DUNLOP Tire	-Reifen -Pneumatico			1		1					1		1								
7	247308	Roue, nue 9x18 8T P15 D19/275 Wheel, stripped	-Rad, allein -Ruota, nudo		1		1						1		1								
8	60665	Valve Válvula	-Ventil -Valvola		1		1						1		1								
9	264859	Roue arrière complète trasera completa posteriore completa	-Komplett hinter rad -Complete rear wheel -Rueda -Ruota						2		2					2			2				
10	259993	Enveloppe 340/80 R18 XMCL 143A8 MICH. Tire	-Reifen -Pneumatico						1		1					1			1				
11	247312	Roue, nue 11x18 8T P25 D21/275 Wheel, stripped	-Rad, allein -Ruota, nudo -Wiel, excl.						1		1					1			1				
12	60665	Valve Válvula	-Ventil -Valvola						1		1					1			1				
13	247315	Roue arrière complète completa completa	-Komplett hinter rad -Complete rear wheel -Rueda trasera -Ruota posteriore						2		2					2			2				

+

Catalogue : 647483

Rep Hinw Fig Item Rif	Numéro Teil-Nr Numero Part-Nr Part-Nr	Désignation Bezeichnung Descripcion Description Descrizione	Qte-Menge-Cant-Qty-Q.ta										3 AA 8002									
			1	2	3	4	5	6	7	8	9	10	11	12	13	14	15	16	17	18	19	20
2		ROUES ARRIERE HINTER RAD RUEDAS TRASERA REAR WHEELS RUOTE POSTERIORE	1- M26- 2 ST3B 2- M26- 4 ST3B 3- M30- 2 ST3B 4- M30- 4 ST3B 5- M40- 2 ST3B 6- M40- 4 ST3B 7- M50- 2 ST3B 8- M50- 4 ST3B 9- M26- 2H ST3B 10-M26- 4H ST3B										11 - M30- 2H ST3B 12 - M30- 4H ST3B 13 - M40- 2H ST3B 14 - M40- 4H ST3B 15 - M50- 2H ST3B 16 - M50- 4H ST3B 17 - 18 - 19 - 20 -									
14	207130	Enveloppe 10R17.5 134M G291 GOODYEAR Tire Rengas	-Reifen -Pneumatico	-Neumático -Band																		
15	247314	Roue, nue 6,75x17,5 6T D0 D21/205 Wheel, stripped	-Rad, allein -Ruota, nudo	-Rueda, sola																		
16	38774	Valve Valve	-Ventil -Valvola	-Válvula																		
17	247292	Ecrou de roue rueda	-Radmutter -Wheel nut	-Tuerca de -Dado ruote	16	16	16	16	16	16	16	16	16	16	16	16	16	16	16	16		

M

4 AA 8003

ADAPTATION MOTEUR-TRANSMISSION
MOTOR-GETRIEBE ANPASSUNG
ADAPTACION MOTOR-TRANSMISION
ENGINE-TRANSMISSION ADAPTATION
ADATTAMENTO MOTORE - TRASMISSIONE

M 26-2/4 ST3B	M 26-2/4H ST3B
M 30-2/4 ST3B	M 30-2/4H ST3B
M 40-2/4 ST3B	M 40-2/4H ST3B
M 50-2/4 ST3B	M 50-2/4H ST3B

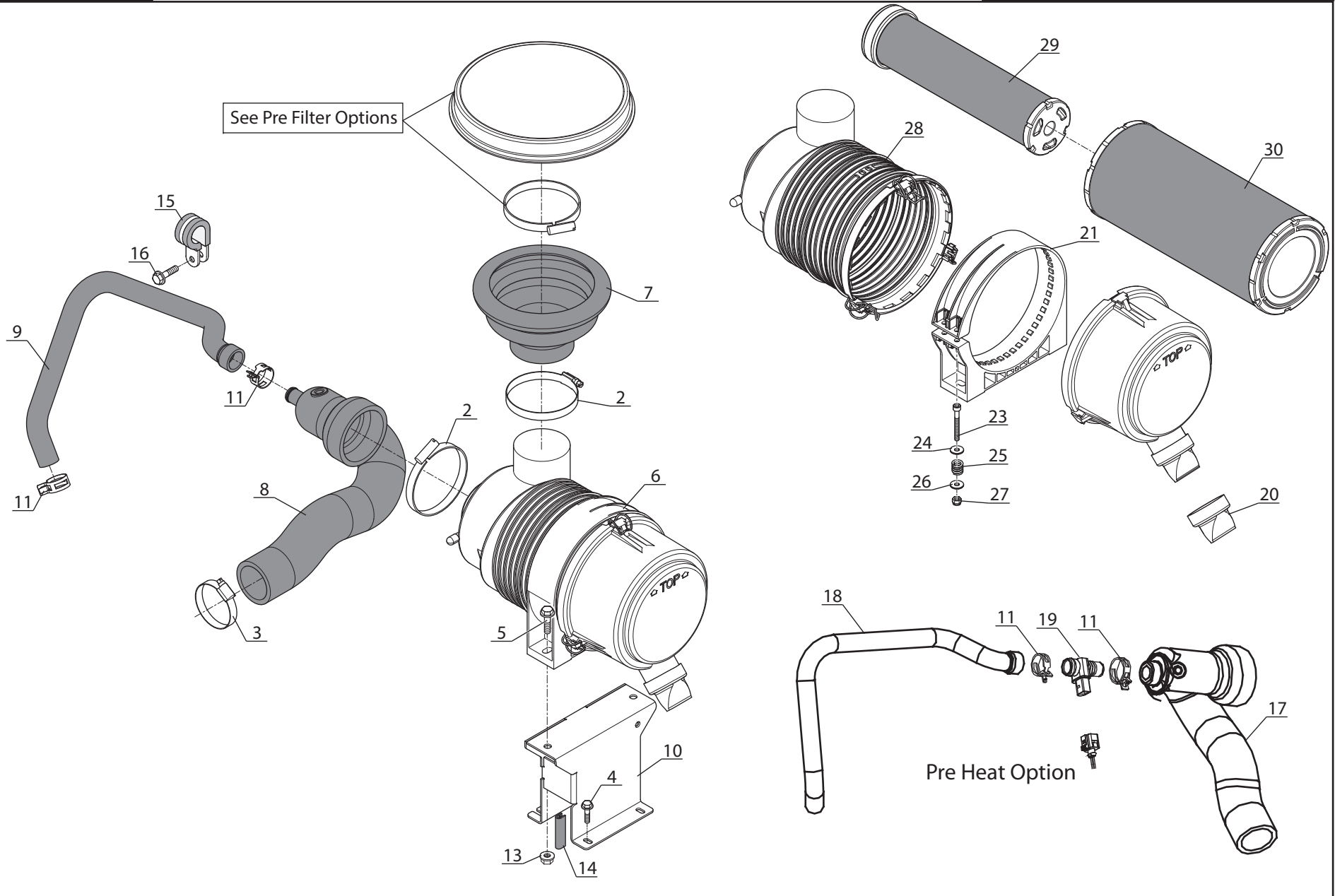

P.A.O. illus

Catalogue : 647483

1	ADAPTATION MOTEUR-TRANSMISSION MOTOR-GETRIEBE ANPASSUNG ADAPTACION MOTOR-TRANSMISION ENGINE-TRANSMISSION ADAPTATION ADATTAMENTO MOTORE - TRASMISSIONE			Qte-Menge-Cant-Qty-Q.ta										4 AA 8003									
	Rep Hinw Fig Item Rif	Numéro Teil-Nr Numero Part-Nr Part-Nr	Désignation Bezeichnung Descripcion Description Descrizione	1	2	3	4	5	6	7	8	9	10	11	12	13	14	15	16	17	18	19	20
2	B2236-13	Collier - Spannschelle -Abrazadera Clamp,2-9/16-3-1/2 Hose - Fascetta	2	2	2	2	2	2	2	2	2	2	2	2	2	2	2	2	2				
3	232027	Collier - Spannschelle - Abrazadera Clamp - Fascetta	1	1	1	1	1	1	1	1	1	1	1	1	1	1	1	1	1				
4	232750	Vis H EMB M 6-16-8.8-ZN8/C - Schraube - Tornillo Screw - Vite	4	4	4	4	4	4	4	4	4	4	4	4	4	4	4	4	4				
5	264380	Vis H EMB M 8-25 8.8-ZN8/C - Schraube - Tornillo Screw - Vite	2	2	2	2	2	2	2	2	2	2	2	2	2	2	2	2	2				
6	308487	Filtre à air complet - Kompletter luftfilter - Filtro de aire completo - Complete air filter -Filtro aria completo	1	1	1	1	1	1	1	1	1	1	1	1	1	1	1	1	1				
7	300469	Soufflet - Blasebalg - Fuelle Bellows - Soffietto	1	1	1	1	1	1	1	1	1	1	1	1	1	1	1	1	1				
8	307739	Durit air - Schlauch - Tubo flexible Hose - Manicotto	1	1	1	1	1	1	1	1	1	1	1	1	1	1	1	1	1				
9	300520	Durit - Schlauch - Tubo flexible Hose - Manicotto	1	1	1	1	1	1	1	1	1	1	1	1	1	1	1	1	1				
10	51300488	Support - Halter - Soporte Support Air Filt. Comp. - Supporto	1	1	1	1	1	1	1	1	1	1	1	1	1	1	1	1	1				
11	B2236-6	Collier - Spannschelle - Abrazadera Clamp, Hose Worm Gear - Fascetta	2	2	2	2	2	2	2	2	2	2	2	2	2	2	2	2	2				
13	254177	Ecrou H EMB M 8 C8ZN8/C - Mutter - Tuerca Nut - Dado	2	2	2	2	2	2	2	2	2	2	2	2	2	2	2	2	2				
14	200583	Joint profilé - Dichtungsstreifen - Junta perfilada Weatherstrip - Guarnizióne	1	1	1	1	1	1	1	1	1	1	1	1	1	1	1	1	1				
15	249209	Collier - Spannschelle - Abrazadera Clamp - Fascetta	1	1	1	1	1	1	1	1	1	1	1	1	1	1	1	1	1				
16	259946	Vis H EMB M 8-168.8DIN6921 - Schraube - Tornillo Screw - Vite	1	1	1	1	1	1	1	1	1	1	1	1	1	1	1	1	1				

+

Catalogue : 647483

2	ADAPTATION MOTEUR-TRANSMISSION MOTOR-GETRIEBE ANPASSUNG ADAPTACION MOTOR-TRANSMISION ENGINE-TRANSMISSION ADAPTATION ADATTAMENTO MOTORE - TRASMISSIONE			Qte-Menge-Cant-Qty-Q.ta										4 AA 8003									
	Rep Hinw Fig Item Rif	Número Teil-Nr Numero Part-Nr Part-Nr	Désignation Bezeichnung Descripcion Description Descrizione	1	2	3	4	5	6	7	8	9	10	11	12	13	14	15	16	17	18	19	20
				1- M26- 2 ST3B	11 - M30- 2H ST3B																		
				2- M26- 4 ST3B	12 - M30- 4H ST3B																		
				3- M30- 2 ST3B	13 - M40- 2H ST3B																		
				4- M30- 4 ST3B	14 - M40- 4H ST3B																		
				5- M40- 2 ST3B	15 - M50- 2H ST3B																		
				6- M40- 4 ST3B	16 - M50- 4H ST3B																		
				7- M50- 2 ST3B	17 -																		
				8- M50- 4 ST3B	18 -																		
				9- M26- 2H ST3B	19 -																		
				10-M26- 4H ST3B	20 -																		
17	307731	Durit air - Schlauch - Tubo flexible Hose/Filter Turbo 55kw Opt Bh - Manicotto	0	0	0	0	0	0	0	0	0	0	0	0	0	0	0	0					
18	306026	Durit air - Schlauch - Tubo flexible Hose/Breather 55kw Option Bh - Manicotto	0	0	0	0	0	0	0	0	0	0	0	0	0	0	0	0					
19	304795	Reniflard (Réservoir) - Entlüftung (Behälter) - Respiradero (Depósito) - Heated Breather Connector - Sfiato (Serbatoio)	0	0	0	0	0	0	0	0	0	0	0	0	0	0	0	0					
20	797905	Clapet d'aspiration - Einlassventil - Entrada de la valv. Vacuator valve - Valvola di ingresso	1	1	1	1	1	1	1	1	1	1	1	1	1	1	1	1					
21	308485	Support filtre à air - Luftfilter träger - Sop. filtro de aire Air filter bracket - Supporto filtro aria	1	1	1	1	1	1	1	1	1	1	1	1	1	1	1	1					
22	250606	Fusible (mini 3 A) - Lichtsicherung - Fusible Fuse - Fusibile	0	0	0	0	0	0	0	0	0	0	0	0	0	0	0	0					
23	797908	Vis CHC 6 - Schraube - Tornillo Screw - Vite	2	2	2	2	2	2	2	2	2	2	2	2	2	2	2	2					
24	797907	Rondelle - Unterlegscheibe - Arandela Washer - Rondella	2	2	2	2	2	2	2	2	2	2	2	2	2	2	2	2					
25	797906	Ressort - Feder - Muelle Spring - Molla	2	2	2	2	2	2	2	2	2	2	2	2	2	2	2	2					
26	797909	Rondelle - Unterlegscheibe - Arandela Washer - Rondella	2	2	2	2	2	2	2	2	2	2	2	2	2	2	2	2					
27	797910	Ecrou H M6 - Mutter - Tuerca Nut - Dado	2	2	2	2	2	2	2	2	2	2	2	2	2	2	2	2					
28	300468	Filtre à air - Luftfilter - Filtro de aire Air filter - Filtro aria	1	1	1	1	1	1	1	1	1	1	1	1	1	1	1	1					
29	797904	Cart séc filtre à air - Sicherheit luftfiltereinsatz - Cartucho seguridad filt. de aire - Security air filter cartridge Cart. di sicurezza filtro aria	1	1	1	1	1	1	1	1	1	1	1	1	1	1	1	1					
30	797903	Cart filtre à air - Luftfiltereinsatz - Cart. filt. de aire Air filter cartridge - Cartuccia filtro aria	1	1	1	1	1	1	1	1	1	1	1	1	1	1	1	1					

4 AA 8004

ADAPTATION MOTEUR-TRANSMISSION
MOTOR-GETRIEBE ANPASSUNG
ADAPTACION MOTOR-TRANSMISION
ENGINE-TRANSMISSION ADAPTATION
ADATTAMENTO MOTORE - TRASMISSIONE

M 26-2/4 ST3B	M 26-2/4H ST3B
M 30-2/4 ST3B	M 30-2/4H ST3B
M 40-2/4 ST3B	M 40-2/4H ST3B
M 50-2/4 ST3B	M 50-2/4H ST3B

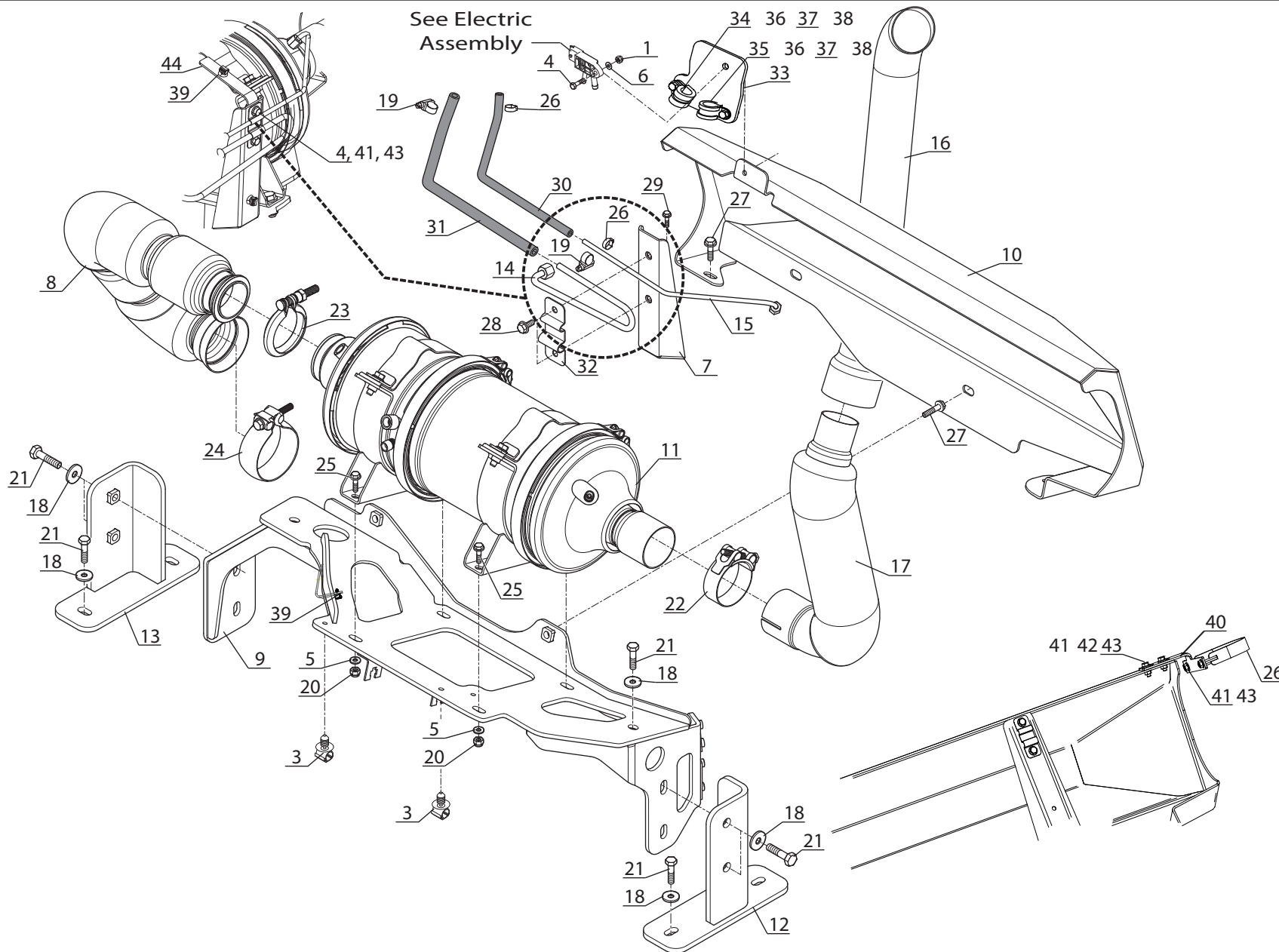

P.A.O. illus

Catalogue : 647483

1	ADAPTATION MOTEUR-TRANSMISSION MOTOR-GETRIEBE ANPASSUNG ADAPTACION MOTOR-TRANSMISION ENGINE-TRANSMISSION ADAPTATION ADATTAMENTO MOTORE - TRASMISSIONE			Qte-Menge-Cant-Qty-Q.ta										4 AA 8004									
	Rep Hinw Fig Item Rif	Numéro Teil-Nr Numero Part-Nr Part-Nr	Désignation Bezeichnung Descripcion Description Descrizione	1	2	3	4	5	6	7	8	9	10	11	12	13	14	15	16	17	18	19	20
				1	1	1	1	1	1	1	1	1	1	1	1	1	1	1	1				
				3	1	1	1	1	1	1	1	1	1	1	1	1	1	1	1				
				4	2	2	2	2	2	2	2	2	2	2	2	2	2	2	2				
				5	1	1	1	1	1	1	1	1	1	1	1	1	1	1	1				
				6	1	1	1	1	1	1	1	1	1	1	1	1	1	1	1				
				7	1	1	1	1	1	1	1	1	1	1	1	1	1	1	1				
				8	9	9	9	9	9	9	9	9	9	9	9	9	9	9	9				
				9	2	2	2	2	2	2	2	2	2	2	2	2	2	2	2				
				10	4	4	4	4	4	4	4	4	4	4	4	4	4	4	4				
				11	9	9	9	9	9	9	9	9	9	9	9	9	9	9	9				
				12	1	1	1	1	1	1	1	1	1	1	1	1	1	1	1				
				13	1	1	1	1	1	1	1	1	1	1	1	1	1	1	1				
				14	1	1	1	1	1	1	1	1	1	1	1	1	1	1	1				
				15	1	1	1	1	1	1	1	1	1	1	1	1	1	1	1				

M

+

Catalogue : 647483

2	ADAPTATION MOTEUR-TRANSMISSION MOTOR-GETRIEBE ANPASSUNG ADAPTACION MOTOR-TRANSMISION ENGINE-TRANSMISSION ADAPTATION ADATTAMENTO MOTORE - TRASMISSIONE			Qte-Menge-Cant-Qty-Q.ta										4 AA 8004									
	Rep Hinw Fig Item Rif	Numéro Teil-Nr Numero Part-Nr Part-Nr	Désignation Bezeichnung Descripcion Description Descrizione	1	2	3	4	5	6	7	8	9	10	11	12	13	14	15	16	17	18	19	20
16	301035	Tuyau d'échappement Exhaust pipe	- Abgasrohr - Tubo de escape - Tubo marmitta	1	1	1	1	1	1	1	1	1	1	1	1	1	1	1					
17	312165	Tube Tube Outlet DPF M30-50-70	- Rohr - Tubo	1	1	1	1	1	1	1	1	1	1	1	1	1	1	1					
18	42366	Rondelle SP 10,5x 30x3ZN Washer	- Unterlegscheibe - Rondella	9	9	9	9	9	9	9	9	9	9	9	9	9	9	9					
19	B2236-11	Collier Clamp	- Spannschelle - Fascetta	4	4	4	4	4	4	4	4	4	4	4	4	4	4	4					
20	55714	Ecrou H,FR M10 zingué Nut	- Mutter - Dado	4	4	4	4	4	4	4	4	4	4	4	4	4	4	4					
21	63544	Vis H,M10- 30-8.8-ZN8/C Screw	- Schraube - Vite	9	9	9	9	9	9	9	9	9	9	9	9	9	9	9					
22	299703	Collier Clamp	- Spannschelle - Fascetta	1	1	1	1	1	1	1	1	1	1	1	1	1	1	1					
23	296467	Collier Clamp	- Spannschelle - Fascetta	1	1	1	1	1	1	1	1	1	1	1	1	1	1	1					
24	296465	Collier Clamp	- Spannschelle - Fascetta	1	1	1	1	1	1	1	1	1	1	1	1	1	1	1					
25	248096	Vis H EMB M10-25 8.8 DIN6921 Screw	- Schraube - Vite	4	4	4	4	4	4	4	4	4	4	4	4	4	4	4					
26	312192	Collier Clamp	- Spannschelle - Fascetta	1	1	1	1	1	1	1	1	1	1	1	1	1	1	1					
27	259602	Vis H EMB M10-20 8.8 DIN6921 Screw	- Schraube - Vite	3	3	3	3	3	3	3	3	3	3	3	3	3	3	3					
28	278713	Vis H EMB M 6-10-8.8-ZN8/C Screw	- Schraube - Vite	2	2	2	2	2	2	2	2	2	2	2	2	2	2	2					
29	286341	Vis H EMB M 8-12-8.8-ZN8/C Screw	- Schraube - Vite	1	1	1	1	1	1	1	1	1	1	1	1	1	1	1					

M

+

Catalogue : 647483

3	ADAPTATION MOTEUR-TRANSMISSION MOTOR-GETRIEBE ANPASSUNG ADAPTACION MOTOR-TRANSMISION ENGINE-TRANSMISSION ADAPTATION ADATTAMENTO MOTORE - TRASMISSIONE			Qte-Menge-Cant-Qty-Q.ta										4 AA 8004									
	Rep Hinw Fig Item Rif	Numéro Teil-Nr Numero Part-Nr Part-Nr	Désignation Bezeichnung Descripcion Description Descrizione	1	2	3	4	5	6	7	8	9	10	11	12	13	14	15	16	17	18	19	20
30	304221	Durit Ø 6 Hose	- Schlauch - Manicotto	- Tubo flexible	1	1	1	1	1	1	1	1	1	1	1	1	1	1	1				
31	304222	Durit Ø 8 Hose	-Schlauch -Manicotto	-Tubo flexible	1	1	1	1	1	1	1	1	1	1	1	1	1	1	1				
32	51300476	Collier Clamp	-Spannschelle -Fascetta	-Abrazadera	1	1	1	1	1	1	1	1	1	1	1	1	1	1	1				
33	309691	Plaque de protection Plate Clamp Mount	- Schützplatte - Piastra di protezione	- Placa de protección	1	1	1	1	1	1	1	1	1	1	1	1	1	1	1				
34	486949	Collier Clamp	- Spannschelle - Fascetta	- Abrazadera	1	1	1	1	1	1	1	1	1	1	1	1	1	1	1				
35	86503	Collier Clamp	- Spannschelle - Fascetta	- Abrazadera	1	1	1	1	1	1	1	1	1	1	1	1	1	1	1				
36	4240	Vis H,M 5-16-8.8-ZN5/C Screw	- Schraube - Vite	- Tornillo	2	2	2	2	2	2	2	2	2	2	2	2	2	2	2				
37	192310	Rondelle JZC5 CAD.BICH Washer	- Unterlegscheibe - Rondella	- Arandela	2	2	2	2	2	2	2	2	2	2	2	2	2	2	2				
38	54232	Ecrou H ,M 5 ZN Nut	- Mutter - Dado	- Tuerca	2	2	2	2	2	2	2	2	2	2	2	2	2	2	2				
39	286994	Collier Clamp	- Spannschelle - Fascetta	- Abrazadera	4	4	4	4	4	4	4	4	4	4	4	4	4	4	4				
40	312170	Plaque de protection Mount	- Schützplatte - Placa de protección	- Plate Clamp - Piastra di	1	1	1	1	1	1	1	1	1	1	1	1	1	1	1				
41	25714	Ecrou H,FR M10 zingué Nut	- Mutter -Dado	- Tuerca	3	3	3	3	3	3	3	3	3	3	3	3	3	3	3				
42	232750	Vis H EMB M10-25 8.8DIN6921 Screw	- Schraube - Vite	- Tornillo	3	3	3	3	3	3	3	3	3	3	3	3	3	3	3				
43	174132	Rondelle JZC 5 CAD.BICH Washer	- Unterlegscheibe - Rondella	- Arandela	5	5	5	5	5	5	5	5	5	5	5	5	5	5	5				

M

+

Catalogue : 647483

4	ADAPTATION MOTEUR-TRANSMISSION MOTOR-GETRIEBE ANPASSUNG ADAPTACION MOTOR-TRANSMISION ENGINE-TRANSMISSION ADAPTATION ADATTAMENTO MOTORE - TRASMISSIONE			Qte-Menge-Cant-Qty-Q.ta										4 AA 8004															
	1- M26- 2 ST3B	11 - M30- 2H ST3B	2- M26- 4 ST3B	12 - M30- 4H ST3B	3- M30- 2 ST3B	13 - M40- 2H ST3B	4- M30- 4 ST3B	14 - M40- 4H ST3B	5- M40- 2 ST3B	15 - M50- 2H ST3B	6- M40- 4 ST3B	16 - M50- 4H ST3B	7- M50- 2 ST3B	17 -	8- M50- 4 ST3B	18 -	9- M26- 2H ST3B	19 -	10-M26- 4H ST3B	20 -									
Rep Hinw Fig Item Rif	Numéro Teil-Nr Numero Part-Nr Part-Nr	Désignation Bezeichnung Descripcion Description Descrizione		1	2	3	4	5	6	7	8	9	10	11	12	13	14	15	16	17	18	19	20						
44	51300853	Tôle Angle Bracket	- Blech - Supporto	- Soporte	1	1	1	1	1	1	1	1	1	1	1	1	1	1	1	1	1	1	1						

M

4 AA 8005

ADAPTATION MOTEUR-TRANSMISSION
MOTOR-GETRIEBE ANPASSUNG
ADAPTACION MOTOR-TRANSMISION
ENGINE-TRANSMISSION ADAPTATION
ADATTAMENTO MOTORE - TRASMISSIONE

M 26-2/4 ST3B	M 26-2/4H ST3B
M 30-2/4 ST3B	M 30-2/4H ST3B
M 40-2/4 ST3B	M 40-2/4H ST3B
M 50-2/4 ST3B	M 50-2/4H ST3B

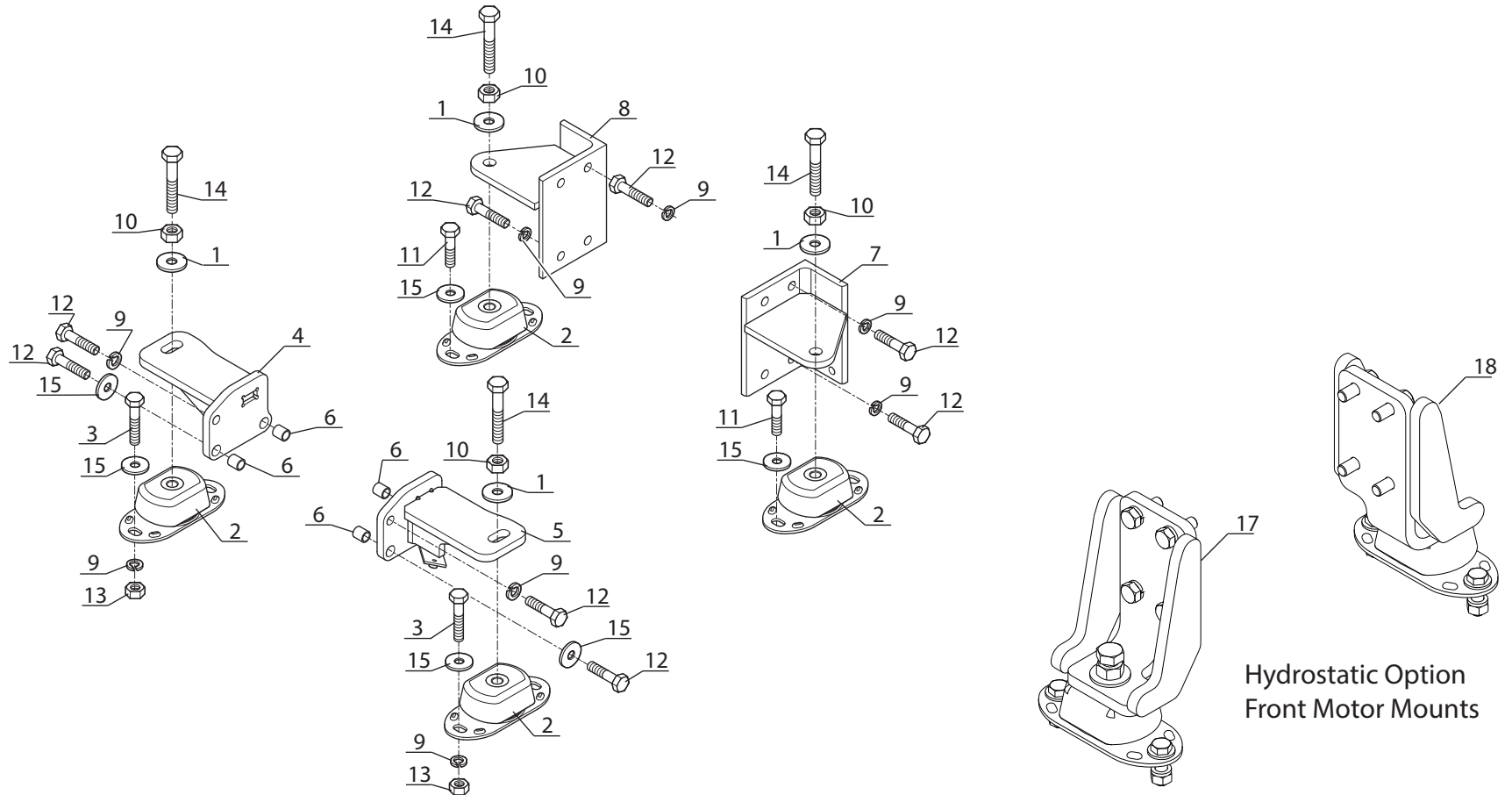

Hydrostatic Option
Front Motor Mounts

Catalogue : 647483

1	ADAPTATION MOTEUR-TRANSMISSION MOTOR-GETRIEBE ANPASSUNG ADAPTACION MOTOR-TRANSMISION ENGINE-TRANSMISSION ADAPTATION ADATTAMENTO MOTORE - TRASMISSIONE			Qte-Menge-Cant-Qty-Q.ta										4 AA 8005									
	Rep Hinw Fig Item Rif	Numéro Teil-Nr Numero Part-Nr Part-Nr	Désignation Bezeichnung Descripcion Description Descrizione	11 - M30- 2H ST3B 12 - M30- 4H ST3B 13 - M40- 2H ST3B 14 - M40- 4H ST3B 15 - M50- 2H ST3B 16 - M50- 4H ST3B 17 - 18 - 19 - 20 -																			
				1	2	3	4	5	6	7	8	9	10	11	12	13	14	15	16	17	18	19	20
1	183812	Rondelle L 16 160HV ZN Arandela Rondella	- Unterlegscheibe - Washer	4	4	4	4	4	4	4	4	4	4	4	4	4	4	4	4	4	4		
2	247802	Silentbloc Amortiguador Tasselo	- Dampfer - Mount/Engine Sim 200 45x70	4	4	4	4	4	4	4	4	4	4	4	4	4	4	4	4	4	4		
3	29450	Vis H,M12- 40-8.8-ZN8/C Tornillo Vite	- Schraube - Screw	4	4	4	4	4	4	4	4	4	4	4	4	4	4	4	4	4	4		
4	300158	Support moteur gauche Soporte motor izquierdo Supporto	- Link motor träger - L.H. engine bracket	1	1	1	1	1	1	1	1	1	1	1	1	1	1	1	1	1	1		
5	300160	Supp. moteur droit Soporte motor derecho Supporto mot. destro	- Recht motor träger - R.H. engine bracket	1	1	1	1	1	1	1	1	1	1	1	1	1	1	1	1	1	1		
6	301228	Bague Anillo Anello	- Büchse - Bushing	4	4	4	4	4	4	4	4	4	4	4	4	4	4	4	4	4	4		
7	301231	Supp. boîte de vitesses av. droit Sop. caja de velocidades del. derecho Supporto cambio anteriore destro	-Träger Getriebe vorne rechts -R.H. front gear box bracket	1	1	1	1	1	1	1	1	1	1	1	1	1	1	1	1	1	1		
8	301232	Support boîte de vitesses av. gauche Soporte caja de velocidades del. izq. Supporto cambio anteriore sinistro	-Träger Getriebe vorne links -L.H. front gear box bracket	1	1	1	1	1	1	1	1	1	1	1	1	1	1	1	1	1	1		
9	42231	Rondelle W12 ZN Arandela Rondella	-Unterlegscheibe - Washer	14	14	14	14	14	14	14	14	14	14	14	14	14	14	14	14	14	14		
10	42813	Ecrou H ,M16 zingué Tuerca Dado	- Mutter - Nut	4	4	4	4	4	4	4	4	4	4	4	4	4	4	4	4	4	4		
11	44807	Vis H,M12- 25-8.8-ZN8/C Tornillo Vite	- Schraube - Screw	1	1	1	1	1	1	1	1	1	1	1	1	1	1	1	1	1	1		

M

+

Catalogue : 647483

2	ADAPTATION MOTEUR-TRANSMISSION MOTOR-GETRIEBE ANPASSUNG ADAPTACION MOTOR-TRANSMISION ENGINE-TRANSMISSION ADAPTATION ADATTAMENTO MOTORE - TRASMISSIONE			Qte-Menge-Cant-Qty-Q.ta										4 AA 8005									
	Rep Hinw Fig Item Rif	Numéro Teil-Nr Numero Part-Nr Part-Nr	Désignation Bezeichnung Descripcion Description Descrizione	1	2	3	4	5	6	7	8	9	10	11	12	13	14	15	16	17	18	19	20
12	58546	Vis H,M12- 35-8.8-ZN8/C Tornillo Vite	- Schraube - Screw	14	14	14	14	14	14	14	14	14	14	14	14	14	14	14	14				
13	58548	Ecrou H ,M12 C 8 ZN..C Tuerca Dado	- Mutter - Nut	4	4	4	4	4	4	4	4	4	4	4	4	4	4	4	4				
14	58590	Vis H,M16- 60-8.8-ZN8/C Tornillo Vite	- Schraube - Screw	4	4	4	4	4	4	4	4	4	4	4	4	4	4	4	4				
15	77710	Rondelle HR12,5x 27x2,5ZN Arandela Rondella	- Unterlegscheibe - Washer	12	12	12	12	12	12	12	12	12	12	12	12	12	12	12	12				
16	187526	Loctite Loctite Loctite	- Loctite - Loctite	0	0	0	0	0	0	0	0	0	0	0	0	0	0	0	0				
17	51300826	Supp. moteur Avant Montaje de Motor, Frontal Frontale Motor Mount	- Vordere Motorhalterung - Motor Mount Front M50																				
18	51300816	Supp. moteur Avant Montaje de Motor, Frontal Frontale Motor Mount	- Vordere Motorhalterung - Motor Mount Front M30										2	2	2	2							

M

4 AA 8006

ADAPTATION MOTEUR-TRANSMISSION
MOTOR-GETRIEBE ANPASSUNG
ADAPTACION MOTOR-TRANSMISION
ENGINE-TRANSMISSION ADAPTATION
ADATTAMENTO MOTORE - TRASMISSIONE

M 26-2/4 ST3B	M 26-2/4H ST3B
M 30-2/4 ST3B	M 30-2/4H ST3B
M 40-2/4 ST3B	M 40-2/4H ST3B
M 50-2/4 ST3B	M 50-2/4H ST3B

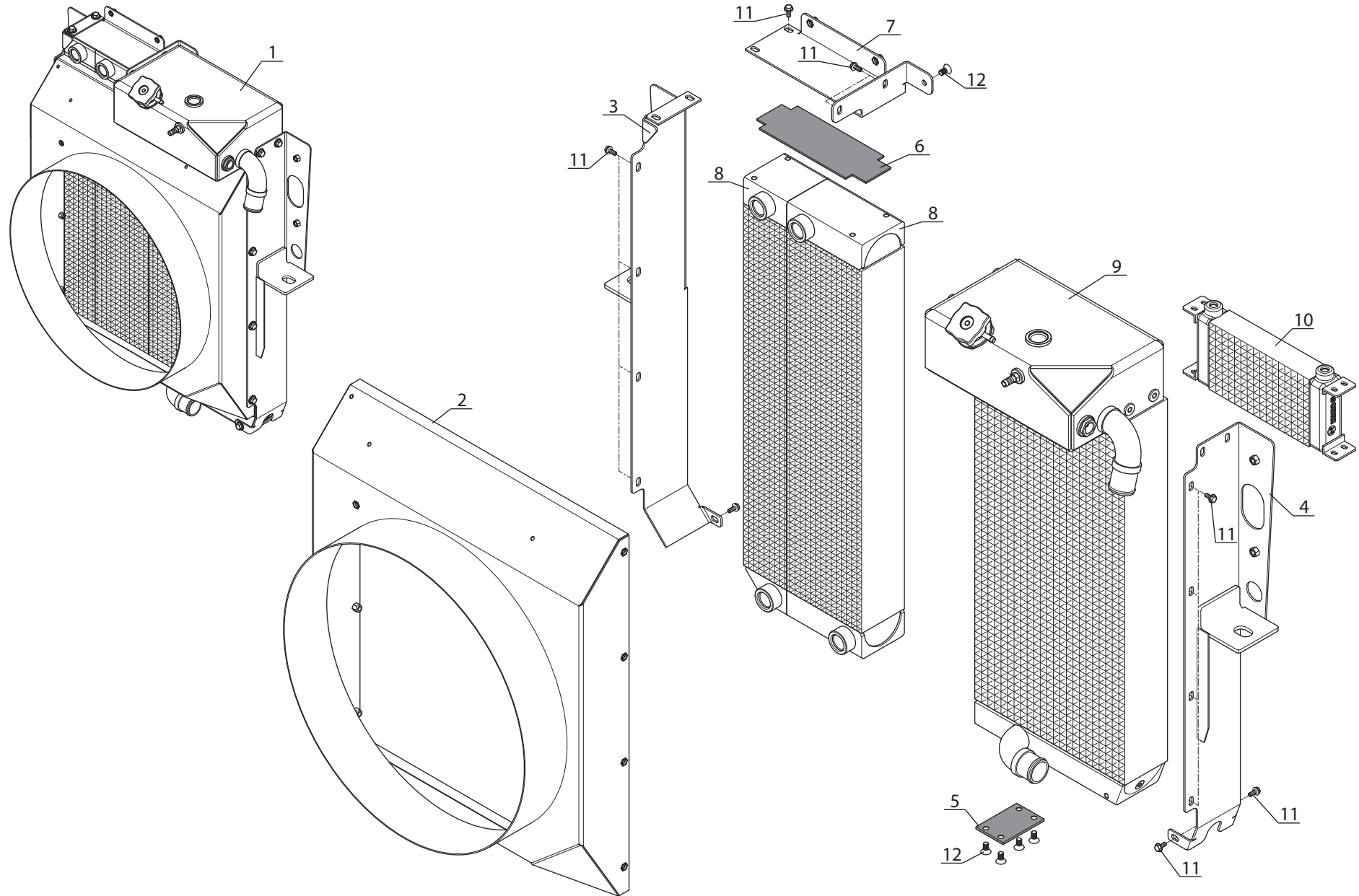

Catalogue : 647483

2	ADAPTATION MOTEUR-TRANSMISSION MOTOR-GETRIEBE ANPASSUNG ADAPTACION MOTOR-TRANSMISION ENGINE-TRANSMISSION ADAPTATION ADATTAMENTO MOTORE - TRASMISSIONE			Qte-Menge-Cant-Qty-Q.ta										4 AA 8006									
	Rep Hinw Fig Item Rif	Numéro Teil-Nr Numero Part-Nr Part-Nr	Désignation Bezeichnung Descripcion Description Descrizione	1	2	3	4	5	6	7	8	9	10	11	12	13	14	15	16	17	18	19	20
12	181673	Vis FHc,M 8- 16-10.9-ZN8/C Tornillo Vite	- Schraube - Screw	1	1	1	1	1	1	1	1	1	1	1	1	1	1	1	1				

M

4 AA 8007

ADAPTATION MOTEUR-TRANSMISSION
MOTOR-GETRIEBE ANPASSUNG
ADAPTACION MOTOR-TRANSMISION
ENGINE-TRANSMISSION ADAPTATION
ADATTAMENTO MOTORE - TRASMISSIONE

M 26-2/4 ST3B M 26-2/4H ST3B
M 30-2/4 ST3B M 30-2/4H ST3B

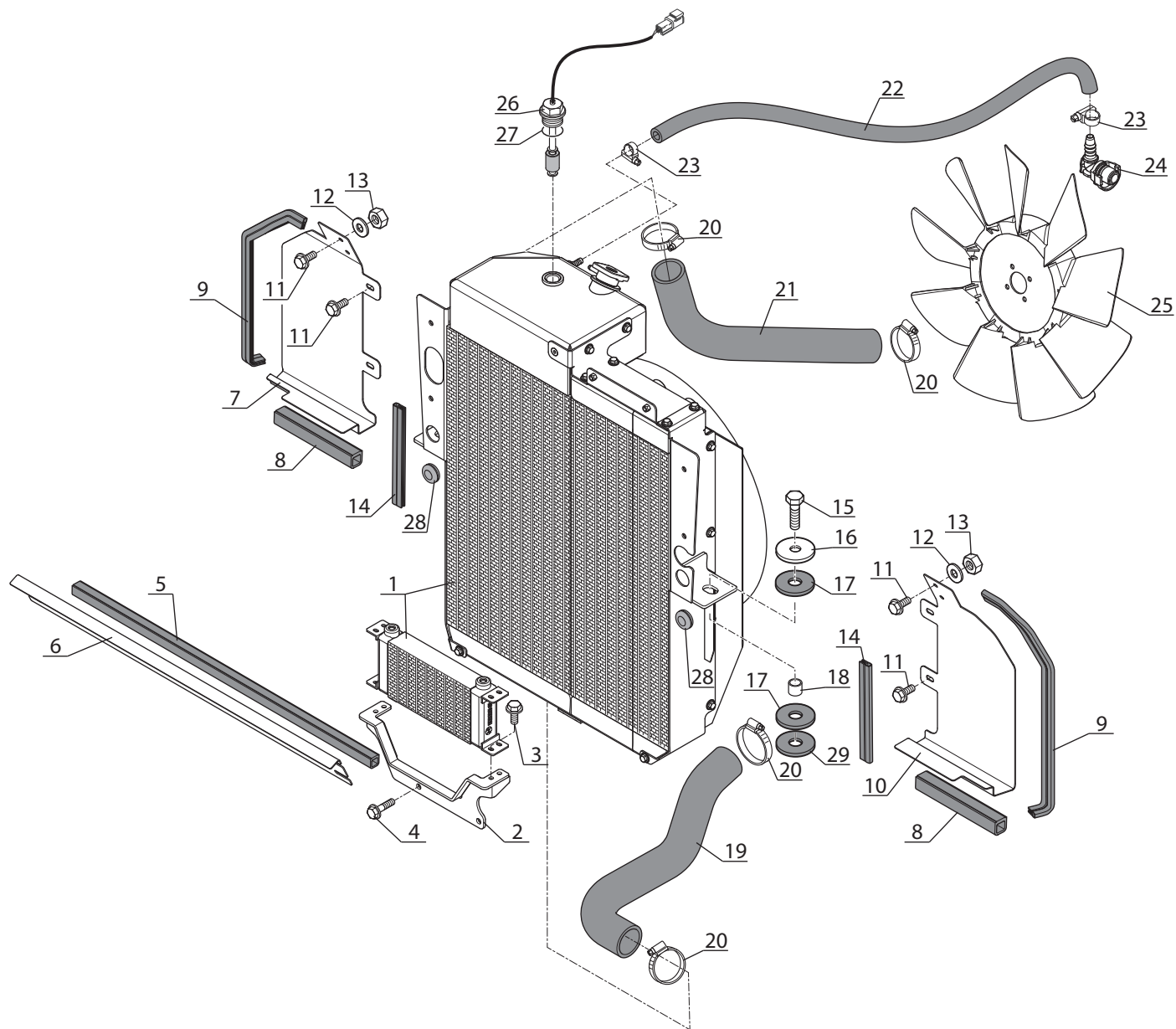

Catalogue : 647483

			Qte-Menge-Cant-Qty-Q.ta																	4 AA 8007					M		
Rep Hinw Fig Item Rif	Numéro Teil-Nr Numero Part-Nr Part-Nr	Désignation Bezeichnung Descripcion Description Descrizione																									
1		ADAPTATION MOTEUR-TRANSMISSION MOTOR-GETRIEBE ANPASSUNG ADAPTACION MOTOR-TRANSMISION ENGINE-TRANSMISSION ADAPTATION ADATTAMENTO MOTORE - TRASMISSIONE																									
			1- M26- 2 ST3B	11 - M30- 2H ST3B																							
			2- M26- 4 ST3B	12 - M30- 4H ST3B																							
			3- M30- 2 ST3B	13 - M40- 2H ST3B																							
			4- M30- 4 ST3B	14 - M40- 4H ST3B																							
			5- M40- 2 ST3B	15 - M50- 2H ST3B																							
			6- M40- 4 ST3B	16 - M50- 4H ST3B																							
			7- M50- 2 ST3B	17 -																							
			8- M50- 4 ST3B	18 -																							
			9- M26- 2H ST3B	19 -																							
			10-M26- 4H ST3B	20 -																							
			1	2	3	4	5	6	7	8	9	10	11	12	13	14	15	16	17	18	19	20					
1	299631	Radiateur complet Radiador completo Radiatore completo	- Kompletter Kühler	1	1	1	1					1	1	1	1												
2	51300447	Support Soporte Supporto	- Träger - Fuel Cooler Supp. Wldmnt	1	1	1	1					1	1	1	1												
3	232750	Vis H EMB M 6-16-8.8-ZN8/C Tornillo Vite	- Schraube - Screw	4	4	4	4					4	4	4	4												
4	279935	Vis H EMB M 8-25 8.8-ZN8/C Tornillo Vite	- Schraube - Screw	2	2	2	2					2	2	2	2												
5	237521	Joint profilé Junta perfilada Guarnizióne	- Dichtungsstreifen - Rubber Prof. 4500426 L 700	1	1	1	1					1	1	1	1												
6	51300452	Tôle Chapa Lamiera	- Blech - Cent. Anti-recycling Shield	1	1	1	1					1	1	1	1												
7	51300451	Tôle Chapa Lamiera	- Blech - Anti-recycl Shield LH	1	1	1	1					1	1	1	1												
8	253693	Joint profilé(Lg 140) Junta perfilada Guarnizióne	- Dichtungsstreifen - Weatherstrip	2	2	2	2					2	2	2	2												
9	250080	Joint profilé (Lg 455) Junta perfilada Guarnizióne	- Dichtungsstreifen - Weatherstrip	2	2	2	2					2	2	2	2												
10	51300450	Tôle Chapa Lamiera	- Blech Anti-recycl Shield RH	1	1	1	1					1	1	1	1												
11	268255	Vis Tornillo Vite	- Schraube - Bolt H Emb M8-16-8.8	8	8	8	8					8	8	8	8												

+

Catalogue : 647483

2	ADAPTATION MOTEUR-TRANSMISSION MOTOR-GETRIEBE ANPASSUNG ADAPTACION MOTOR-TRANSMISION ENGINE-TRANSMISSION ADAPTATION ADATTAMENTO MOTORE - TRASMISSIONE			Qte-Menge-Cant-Qty-Q.ta										4 AA 8007									
	Rep Hinw Fig Item Rif	Número Teil-Nr Numero Part-Nr Part-Nr	Désignation Bezeichnung Descripcion Description Descrizione	1	2	3	4	5	6	7	8	9	10	11	12	13	14	15	16	17	18	19	20
				1- M26- 2 ST3B	11 - M30- 2H ST3B																		
				2- M26- 4 ST3B	12 - M30- 4H ST3B																		
				3- M30- 2 ST3B	13 - M40- 2H ST3B																		
				4- M30- 4 ST3B	14 - M40- 4H ST3B																		
				5- M40- 2 ST3B	15 - M50- 2H ST3B																		
				6- M40- 4 ST3B	16 - M50- 4H ST3B																		
				7- M50- 2 ST3B	17 -																		
				8- M50- 4 ST3B	18 -																		
				9- M26- 2H ST3B	19 -																		
				10-M26- 4H ST3B	20 -																		
12	61674	Rondelle M 8 ZN Arandela Rondella	- Unterlegscheibe - Washer	6	6	6	6					6	6	6	6								
13	58528	Ecrou H ,M 8 ZN Tuerca Dado	- Mutter - Nut	6	6	6	6					6	6	6	6								
14	302159	Joint profilé (Lg 200) Junta perfilada Guarnizióne	- Dichtungsstreifen - Weatherstrip	2	2	2	2					2	2	2	2								
15	63545	Vis H,M10- 30-8.8-ZN8/C Tornillo Vite	- Schraube - Screw	2	2	2	2					2	2	2	2								
16	36010	Rondelle SP 10,5x 45 x 4 ZN Arandela Rondella	- Unterlegscheibe - Washer	2	2	2	2					2	2	2	2								
17	73979	Rondelle caoutchouc Arandela de caucho Rondella gomma	- Gummiunterlegscheibe - Rubber washer	4	4	4	4					4	4	4	4								
18	188791	Entretoise Separador Distanziale	- Querstrebe - Spacer	2	2	2	2					2	2	2	2								
19	299999	Durit inférieure Tubo flexible infe. Manicotto inferiore	- Unter Schlauch - Lower hose	1	1	1	1					1	1	1	1								
20	232025	Collier Abrazadera Fascetta	- Spannschelle - Clamp	4	4	4	4					4	4	4	4								
21	299998	Durit supérieure Tubo flexible supe. Manicotto superiore	- Ober Schlauch - Upper hose	1	1	1	1					1	1	1	1								
22	301941	Durit (Lg 570) Tubo flexible Manicotto	- Schlauch - Hose	1	1	1	1					1	1	1	1								

M

+

Catalogue : 647483

3	ADAPTATION MOTEUR-TRANSMISSION MOTOR-GETRIEBE ANPASSUNG ADAPTACION MOTOR-TRANSMISION ENGINE-TRANSMISSION ADAPTATION ADATTAMENTO MOTORE - TRASMISSIONE		Qte-Menge-Cant-Qty-Q.ta										4 AA 8007																														
	Rep Hinw Fig Item Rif	Numéro Teil-Nr Numero Part-Nr Part-Nr	Désignation Bezeichnung Descripcion Description Descrizione	1- M26- 2 ST3B		11 - M30- 2H ST3B		2- M26- 4 ST3B		12 - M30- 4H ST3B		3- M30- 2 ST3B		13 - M40- 2H ST3B		4- M30- 4 ST3B		14 - M40- 4H ST3B		5- M40- 2 ST3B		15 - M50- 2H ST3B		6- M40- 4 ST3B		16 - M50- 4H ST3B		7- M50- 2 ST3B		17 -		8- M50- 4 ST3B		18 -		9- M26- 2H ST3B		19 -		10-M26- 4H ST3B		20 -	
				1	2	3	4	5	6	7	8	9	10	11	12	13	14	15	16	17	18	19	20																				
23	479218	Collier Abrazadera Fascetta	- Spannschelle - Clamp	2	2	2	2									2	2	2	2																								
24	306355	Connecteur Conectador Connettore	- Verbinder - Connector	1	1	1	1									1	1	1	1																								
25	290765	Ventilateur aspirant Ventilador aspirant Ventola aspirante	- Ventilator saugend - Sucker fan	1	1	1	1									1	1	1	1																								
26	313641	Capteur (Niveau d'eau) Sensor Sónda	- Sensor - Sensor	1	1	1	1									1	1	1	1																								
27	212298	Joint torique Junta tórica Anello OR	- "0" ring - "0" ring	1	1	1	1									1	1	1	1																								
28	213394	Passe-fil Arandela de gaucho Passo-filo	- Gummischeibe - Cable grommet	2	2	2	2									2	2	2	2																								
29	806789	Entretoise Separador Distanziale	- Querstrebe - Spacer	2	2	2	2									2	2	2	2																								

4 AA 8008

ADAPTATION MOTEUR-TRANSMISSION
MOTOR-GETRIEBE ANPASSUNG
ADAPTACION MOTOR-TRANSMISION
ENGINE-TRANSMISSION ADAPTATION
ADATTAMENTO MOTORE - TRASMISSIONE

M 40-2/4 ST3B M 40-2/4H ST3B
M 50-2/4 ST3B M 50-2/4H ST3B

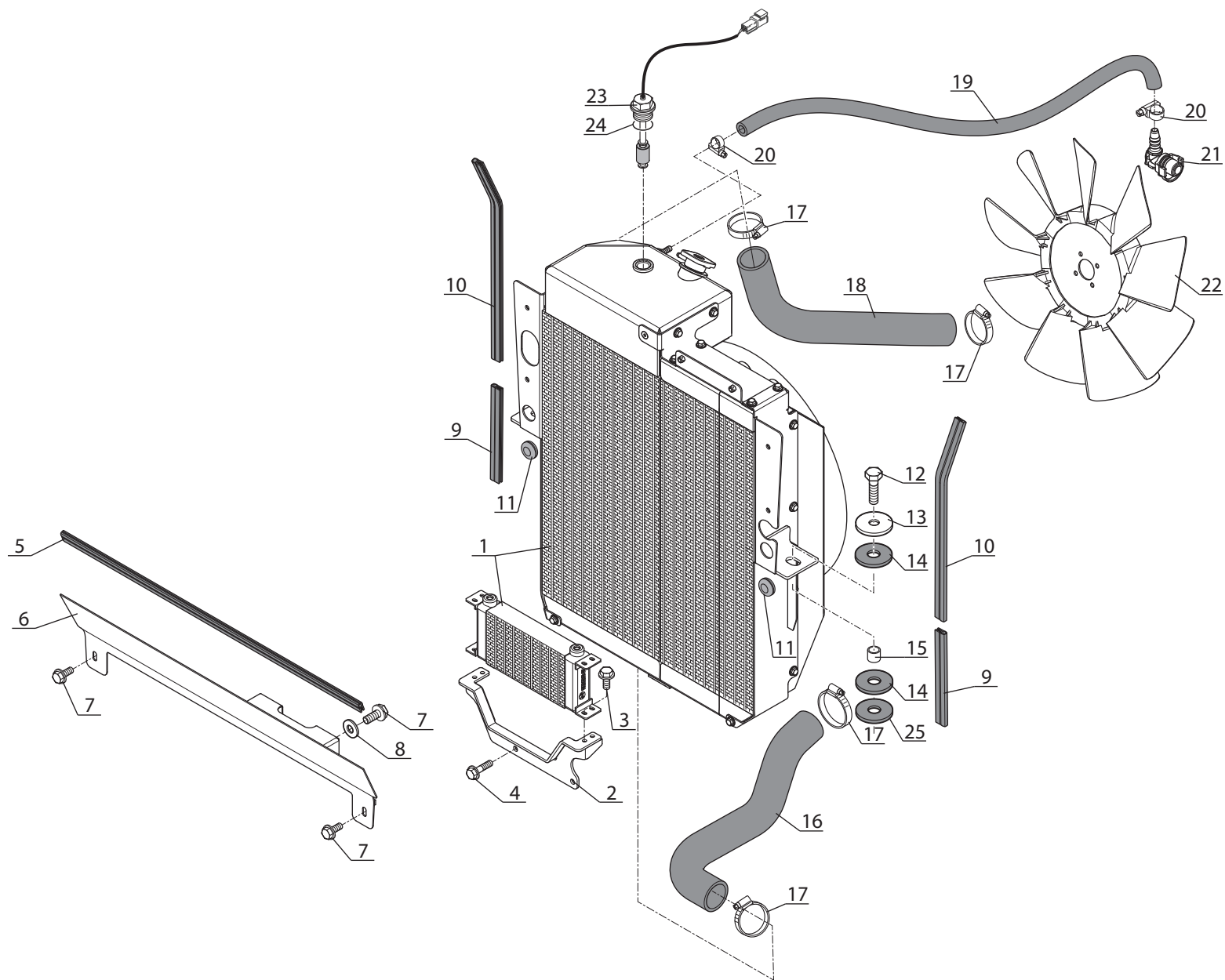

Catalogue : 647483

1			4 AA 8008																			
ADAPTATION MOTEUR-TRANSMISSION MOTOR-GETRIEBE ANPASSUNG ADAPTACION MOTOR-TRANSMISION ENGINE-TRANSMISSION ADAPTATION ADATTAMENTO MOTORE - TRASMISSIONE			1- M26- 2 ST3B 11 - M30- 2H ST3B 2- M26- 4 ST3B 12 - M30- 4H ST3B 3- M30- 2 ST3B 13 - M40- 2H ST3B 4- M30- 4 ST3B 14 - M40- 4H ST3B 5- M40- 2 ST3B 15 - M50- 2H ST3B 6- M40- 4 ST3B 16 - M50- 4H ST3B 7- M50- 2 ST3B 17 - 8- M50- 4 ST3B 18 - 9- M26- 2H ST3B 19 - 10-M26- 4H ST3B 20 -																			
Rep Hinw Fig Item Rif	Numéro Teil-Nr Numero Part-Nr Part-Nr	Désignation Bezeichnung Descripcion Description Descrizione	1	2	3	4	5	6	7	8	9	10	11	12	13	14	15	16	17	18	19	20
1	299631	Radiateur complet Radiador completo Radiatore completo					1	1	1	1					1	1	1	1				
		- Kompletter Kühler - Rad. Mmc Stage3b 55kw																				
2	51300447	Support Soporte Supporto						1	1	1	1				1	1	1	1				
		- Träger - Fuel Cooler Supp. Wldmnt																				
3	232750	Vis H EMB M 6-16-8.8-ZN8/C Tornillo Vite						4	4	4	4				4	4	4	4				
		- Schraube - Screw																				
4	279935	Vis H EMB M 8-25 8.8-ZN8/C Tornillo Vite						2	2	2	2				2	2	2	2				
		- Schraube - Screw																				
5	304060	Joint profilé (Lg 762) Junta perfilada Guarnizione						1	1	1	1				1	1	1	1				
		- Dichtungsstreifen - Trim Lock/Seal 4500405 L762																				
6	51300444	Tôle Chapa Lamiera						1	1	1	1				1	1	1	1				
		- Blech - Anti-recyc.Shield Comp.																				
7	268255	Vis Tornillo Vite						4	4	4	4				4	4	4	4				
		- Schraube - BoltHEmb M8-16-8.8-zn8/C Fr																				
8	44025	Rondelle SP 8,5x 30 x 3 ZN Arandela Rondella						2	2	2	2				2	2	2	2				
		- Unterlegscheibe - Washer																				
9	302159	Joint profilé (Lg 200) Junta perfilada Guarnizione						2	2	2	2				2	2	2	2				
		- Dichtungsstreifen - Weatherstrip																				
10	304059	Joint profilé (Lg 442) Junta perfilada Guarnizione						2	2	2	2				2	2	2	2				
		- Dichtungsstreifen - Weatherstrip																				
11	213394	Passe-fil Arandela de gaucho Passo-filo						2	2	2	2				2	2	2	2				
		- Gummischeibe - Cable grommet																				

M

+

Catalogue : 647483

2	ADAPTATION MOTEUR-TRANSMISSION MOTOR-GETRIEBE ANPASSUNG ADAPTACION MOTOR-TRANSMISION ENGINE-TRANSMISSION ADAPTATION ADATTAMENTO MOTORE - TRASMISSIONE			Qte-Menge-Cant-Qty-Q.ta										4 AA 8008																																																																																									
	Rep Hinw Fig Item Rif	Numéro Teil-Nr Numero Part-Nr Part-Nr	Désignation Bezeichnung Descripcion Description Descrizione	<table style="width: 100%; border-collapse: collapse;"> <tr> <td style="width: 5%;">1-</td><td style="width: 15%;">M26-</td><td style="width: 5%;">2</td><td style="width: 15%;">ST3B</td><td style="width: 5%;">11 -</td><td style="width: 15%;">M30-</td><td style="width: 5%;">2H</td><td style="width: 15%;">ST3B</td> </tr> <tr> <td>2-</td><td>M26-</td><td>4</td><td>ST3B</td><td>12 -</td><td>M30-</td><td>4H</td><td>ST3B</td> </tr> <tr> <td>3-</td><td>M30-</td><td>2</td><td>ST3B</td><td>13 -</td><td>M40-</td><td>2H</td><td>ST3B</td> </tr> <tr> <td>4-</td><td>M30-</td><td>4</td><td>ST3B</td><td>14 -</td><td>M40-</td><td>4H</td><td>ST3B</td> </tr> <tr> <td>5-</td><td>M40-</td><td>2</td><td>ST3B</td><td>15 -</td><td>M50-</td><td>2H</td><td>ST3B</td> </tr> <tr> <td>6-</td><td>M40-</td><td>4</td><td>ST3B</td><td>16 -</td><td>M50-</td><td>4H</td><td>ST3B</td> </tr> <tr> <td>7-</td><td>M50-</td><td>2</td><td>ST3B</td><td>17 -</td><td></td><td></td><td></td> </tr> <tr> <td>8-</td><td>M50-</td><td>4</td><td>ST3B</td><td>18 -</td><td></td><td></td><td></td> </tr> <tr> <td>9-</td><td>M26-</td><td>2H</td><td>ST3B</td><td>19 -</td><td></td><td></td><td></td> </tr> <tr> <td>10-</td><td>M26-</td><td>4H</td><td>ST3B</td><td>20 -</td><td></td><td></td><td></td> </tr> </table>										1-	M26-	2	ST3B	11 -	M30-	2H	ST3B	2-	M26-	4	ST3B	12 -	M30-	4H	ST3B	3-	M30-	2	ST3B	13 -	M40-	2H	ST3B	4-	M30-	4	ST3B	14 -	M40-	4H	ST3B	5-	M40-	2	ST3B	15 -	M50-	2H	ST3B	6-	M40-	4	ST3B	16 -	M50-	4H	ST3B	7-	M50-	2	ST3B	17 -				8-	M50-	4	ST3B	18 -				9-	M26-	2H	ST3B	19 -				10-	M26-	4H	ST3B	20 -													
				1-	M26-	2	ST3B	11 -	M30-	2H	ST3B																																																																																												
2-	M26-	4	ST3B	12 -	M30-	4H	ST3B																																																																																																
3-	M30-	2	ST3B	13 -	M40-	2H	ST3B																																																																																																
4-	M30-	4	ST3B	14 -	M40-	4H	ST3B																																																																																																
5-	M40-	2	ST3B	15 -	M50-	2H	ST3B																																																																																																
6-	M40-	4	ST3B	16 -	M50-	4H	ST3B																																																																																																
7-	M50-	2	ST3B	17 -																																																																																																			
8-	M50-	4	ST3B	18 -																																																																																																			
9-	M26-	2H	ST3B	19 -																																																																																																			
10-	M26-	4H	ST3B	20 -																																																																																																			
				1	2	3	4	5	6	7	8	9	10	11	12	13	14	15	16	17	18	19	20																																																																																
12	63545	Vis H,M10- 30-8.8-ZN8/C Tornillo Vite	- Schraube - Screw					2	2	2	2					2	2	2	2																																																																																				
13	36010	Rondelle SP 10,5x 45 x 4 ZN Arandela Rondella	- Unterlegscheibe - Washer					2	2	2	2					2	2	2	2																																																																																				
14	73979	Rondelle caoutchouc Arandela de caucho Rondella gomma	- Gummiunterlegscheibe - Rubber washer					4	4	4	4					4	4	4	4																																																																																				
15	188791	Entretoise Separador Distanziale	- Querstrebe - Spacer					2	2	2	2					2	2	2	2																																																																																				
16	299999	Durit inférieure Tubo flexible infe. Manicotto inferiore	- Unter Schlauch - Lower hose					1	1	1	1					1	1	1	1																																																																																				
17	232025	Collier Abrazadera Fascetta	- Spannschelle - Clamp					4	4	4	4					4	4	4	4																																																																																				
18	299998	Durit supérieure Tubo flexible supe. Manicotto superiore	- Ober Schlauch - Upper hose					1	1	1	1					1	1	1	1																																																																																				
19	301941	Durit (Lg 570) Tubo flexible Manicotto	- Schlauch - Hose					1	1	1	1					1	1	1	1																																																																																				
20	479218	Collier Abrazadera Fascetta	- Spannschelle - Clamp					2	2	2	2					2	2	2	2																																																																																				
21	306355	Connecteur Conectador Connettore	- Verbinder -Connector					1	1	1	1					1	1	1	1																																																																																				
22	290765	Ventilateur aspirant Ventilador aspirant Ventola aspirante	- Ventilator saugend - Sucker fan					1	1	1	1					1	1	1	1																																																																																				

M

+

Catalogue : 647483

3	ADAPTATION MOTEUR-TRANSMISSION MOTOR-GETRIEBE ANPASSUNG ADAPTACION MOTOR-TRANSMISION ENGINE-TRANSMISSION ADAPTATION ADATTAMENTO MOTORE - TRASMISSIONE			Qte-Menge-Cant-Qty-Q.ta										4 AA 8008									
	Rep Hinw Fig Item Rif	Número Teil-Nr Numero Part-Nr Part-Nr	Désignation Bezeichnung Descripcion Description Descrizione	1	2	3	4	5	6	7	8	9	10	11	12	13	14	15	16	17	18	19	20
23	313641	Capteur (Niveau d'eau) Sensor Sonda	- Sensor - Sensor					1	1	1	1						1	1	1	1			
24	212298	Joint torique Junta tórica Anello OR	- "0" ring - "0" ring					1	1	1	1					1	1	1	1				
25	806789	Entretoise Separador Distanziale	- Querstrebe - Spacer					2	2	2	2					2	2	2	2				

M

4 AA 8009

ADAPTATION MOTEUR-TRANSMISSION
MOTOR-GETRIEBE ANPASSUNG
ADAPTACION MOTOR-TRANSMISION
ENGINE-TRANSMISSION ADAPTATION
ADATTAMENTO MOTORE - TRASMISSIONE

M 26-2/4 ST3B M 26-2/4H ST3B
M 30-2/4 ST3B M 30-2/4H ST3B

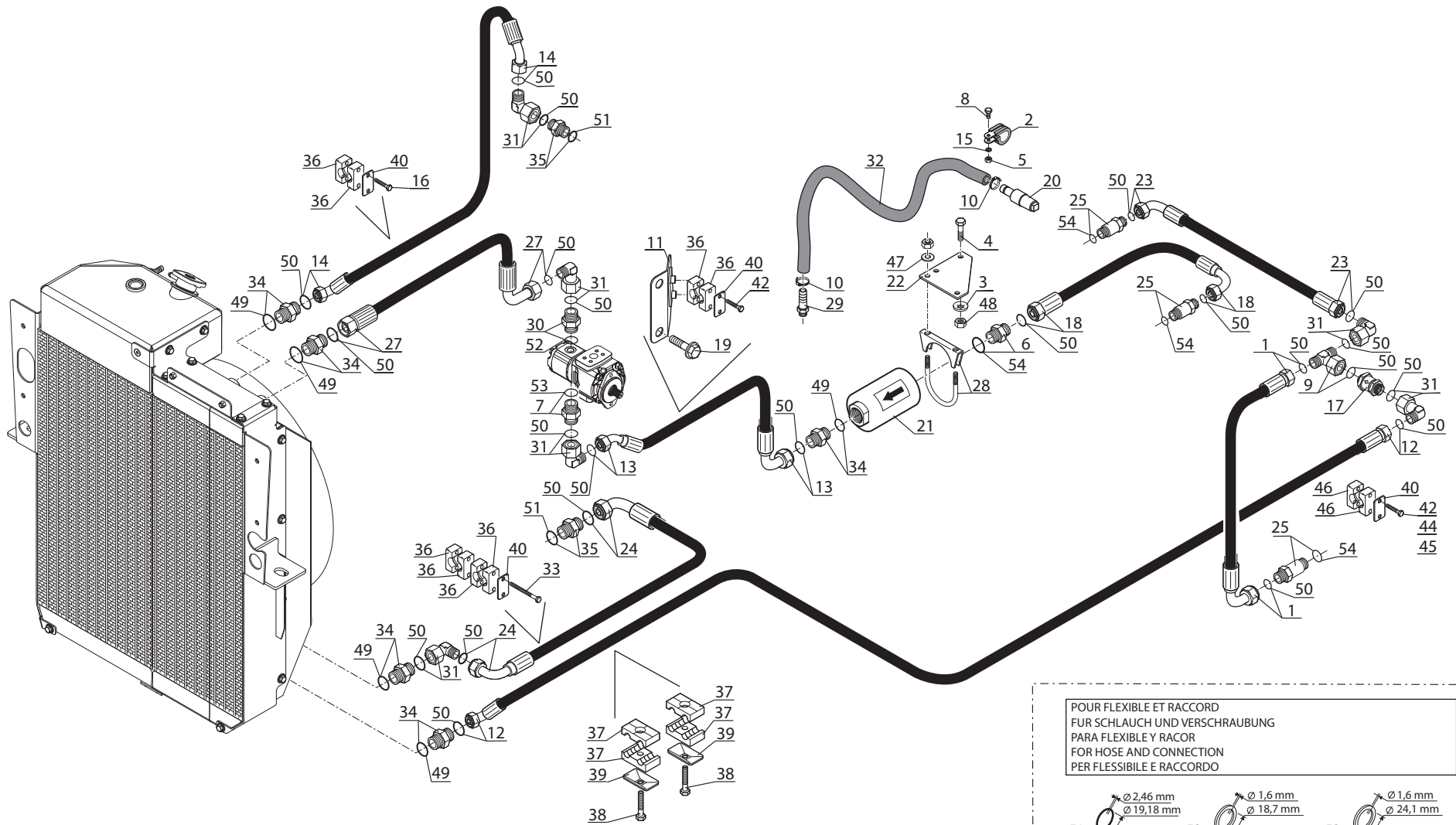

POUR FLEXIBLE ET RACCORD
FÜR SCHLAUCH UND VERSCHRAUBUNG
PARA FLEXIBLE Y RACOR
FOR HOSE AND CONNECTION
PER FLESSIBILE E RACCORDO

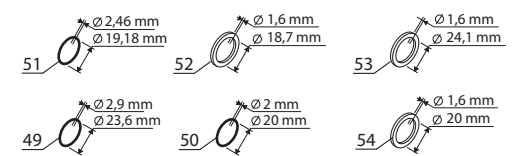

P.A.O. illus

Catalogue : 647483

Rep Hinw Fig Item Rif	Numéro Teil-Nr Numero Part-Nr Part-Nr	Désignation Bezeichnung Descripcion Description Descrizione	Qte-Menge-Cant-Qty-Q.ta										4 AA 8009										
			1	2	3	4	5	6	7	8	9	10	11	12	13	14	15	16	17	18	19	20	
			1		ADAPTATION MOTEUR-TRANSMISSION MOTOR-GETRIEBE ANPASSUNG ADAPTACION MOTOR-TRANSMISION ENGINE-TRANSMISSION ADAPTATION ADATTAMENTO MOTORE - TRASMISSIONE	1- M26- 2 ST3B	11 - M30- 2H ST3B	2- M26- 4 ST3B	12 - M30- 4H ST3B	3- M30- 2 ST3B	13 - M40- 2H ST3B	4- M30- 4 ST3B	14 - M40- 4H ST3B	5- M40- 2 ST3B	15 - M50- 2H ST3B	6- M40- 4 ST3B	16 - M50- 4H ST3B	7- M50- 2 ST3B	17 -	8- M50- 4 ST3B	18 -	9- M26- 2H ST3B	19 -
1	239274	Flexible (Lg 400) Flexible Flessibile	- Schlauch - Hose	1	1	1	1					1	1	1	1								
2	86505	Collier Abrazadera Fascetta	- Spannschelle - Clamp	1	1	1	1					1	1	1	1								
3	63351	Rondelle JZC 8 CAD.BICH Arandela Rondella	- Unterlegscheibe - Washer	2	2	2	2					2	2	2	2								
4	57446	Rondelle M 8 ZN Arandela Rondella	- Unterlegscheibe - Washer	1	1	1	1					1	1	1	1								
5	54232	Ecrou H ,M 5 ZN Tuerca Dado	- Mutter - Nut	1	1	1	1					1	1	1	1								
6	524789	Raccord Union Racor Raccordo	- Verschraubung - Connection	1	1	1	1					1	1	1	1								
7	524788	Raccord Union Racor Raccordo	- Verschraubung - Connection	1	1	1	1					1	1	1	1								
8	54230	Vis H,M 5-16-8.8-ZN5/C Tornillo Vite	- Schraube - Screw	1	1	1	1					1	1	1	1								
9	239197	Raccord Té Racor Raccordo	- Verschraubung - Connection	1	1	1	1					1	1	1	1								
10	31468	Collier Abrazadera Fascetta	- Spannschelle - Clamp	2	2	2	2					2	2	2	2								
11	51300445	Support bride Soporte brida Supporto flangia	- Flansch träger - Flange bracket	1	1	1	1					1	1	1	1								

M

+

Catalogue : 647483

Rep Hinw Fig Item Rif	Numéro Teil-Nr Numero Part-Nr Part-Nr	Désignation Bezeichnung Descripcion Description Descrizione	Qte-Menge-Cant-Qty-Q.ta										4 AA 8009										
			1	2	3	4	5	6	7	8	9	10	11	12	13	14	15	16	17	18	19	20	
			2		ADAPTATION MOTEUR-TRANSMISSION MOTOR-GETRIEBE ANPASSUNG ADAPTACION MOTOR-TRANSMISION ENGINE-TRANSMISSION ADAPTATION ADATTAMENTO MOTORE - TRASMISSIONE	1- M26- 2 ST3B	11 - M30- 2H ST3B	2- M26- 4 ST3B	12 - M30- 4H ST3B	3- M30- 2 ST3B	13 - M40- 2H ST3B	4- M30- 4 ST3B	14 - M40- 4H ST3B	5- M40- 2 ST3B	15 - M50- 2H ST3B	6- M40- 4 ST3B	16 - M50- 4H ST3B	7- M50- 2 ST3B	17 -	8- M50- 4 ST3B	18 -	9- M26- 2H ST3B	19 -
12	306121	Flexible (Lg 2210) Flexible Flessibile	- Schlauch - Hose	1	1	1	1					1	1	1	1								
13	302020	Flexible (Lg 1260) Flexible Flessibile	- Schlauch - Hose	1	1	1	1					1	1	1	1								
14	302017	Flexible (Lg 1675) Flexible Flessibile	- Schlauch - Hose	1	1	1	1					1	1	1	1								
15	29483	Rondelle W 5 ZN Arandela Rondella	- Unterlegscheibe - Washer	1	1	1	1					1	1	1	1								
16	29481	Vis H,M 6-45-8.8-ZN5/C Tornillo Vite	- Schraube - Screw	2	2	2	2					2	2	2	2								
17	264882	Clapet Válvula Valvola	- Klappe - Valve	1	1	1	1					1	1	1	1								
18	264077	Flexible (Lg 2210) Flexible Flessibile	- Schlauch - Hose	1	1	1	1					1	1	1	1								
19	259710	Vis H EMB M12-25 8.8 DIN6921 Tornillo Vite	- Schraube - Screw	2	2	2	2					2	2	2	2								
20	254733	Raccord Union Cranté Racor Raccordo	- Verschraubung - Connection	1	1	1	1					1	1	1	1								
21	254582	Filtre Filtro Filtro	- Filter - Filter	1	1	1	1					1	1	1	1								
22	254578	Support Soporte Supporto	- Träger - Bracket	1	1	1	1					1	1	1	1								

M

+

Catalogue : 647483

3	ADAPTATION MOTEUR-TRANSMISSION MOTOR-GETRIEBE ANPASSUNG ADAPTACION MOTOR-TRANSMISION ENGINE-TRANSMISSION ADAPTATION ADATTAMENTO MOTORE - TRASMISSIONE			Qte-Menge-Cant-Qty-Q.ta										4 AA 8009																													
	Rep Hinw Fig Item Rif	Numéro Teil-Nr Numero Part-Nr Part-Nr	Désignation Bezeichnung Descripcion Description Descrizione	1- M26- 2 ST3B		11 - M30- 2H ST3B		2- M26- 4 ST3B		12 - M30- 4H ST3B		3- M30- 2 ST3B		13 - M40- 2H ST3B		4- M30- 4 ST3B		14 - M40- 4H ST3B		5- M40- 2 ST3B		15 - M50- 2H ST3B		6- M40- 4 ST3B		16 - M50- 4H ST3B		7- M50- 2 ST3B		17 -		8- M50- 4 ST3B		18 -		9- M26- 2H ST3B		19 -		10-M26- 4H ST3B		20 -	
				1	2	3	4	5	6	7	8	9	10	11	12	13	14	15	16	17	18	19	20																				
23	254510	Flexible (Lg 450) Flexible Flessibile	- Schlauch - Hose	1	1	1	1													1	1	1	1																				
24	234274	Flexible Flexible Flessibile	- Schlauch - Hose	1	1	1	1													1	1	1	1																				
25	233728	Raccord Un Prolongateur Racor Raccordo	- Verschraubung - Connection	3	3	3	3													3	3	3	3																				
27	305140	Flexible (Lg 750) Flexible Flessibile	- Schlauch - Hose	1	1	1	1													1	1	1	1																				
28	224928	Collier Abrazadera Fascetta	- Spannschelle - Clamp	1	1	1	1													1	1	1	1																				
29	222381	Reniflard Respiradero Sfiato	- Entlüftung - Air breather	1	1	1	1													1	1	1	1																				
30	218884	Raccord Union Racor Raccordo	- Verschraubung - Connection	1	1	1	1													1	1	1	1																				
31	217044	Raccord Coudé 90° Adap Racor Raccordo	- Verschraubung - Connection	1	1	1	1													1	1	1	1																				
32	211954	Durit (Lg 800) Tubo flexible Manicotto	- Schlauch - Hose	6	6	6	6													6	6	6	6																				
33	205933	Vis H,M 6-90-8.8-ZN5/C Tornillo Vite	- Schraube - Screw	1	1	1	1													1	1	1	1																				
34	205206	Raccord Union Racor Raccordo	- Verschraubung - Connection	2	2	2	2													2	2	2	2																				

M

+

Catalogue : 647483

4	ADAPTATION MOTEUR-TRANSMISSION MOTOR-GETRIEBE ANPASSUNGO ADAPTACION MOTOR-TRANSMISION ENGINE-TRANSMISSION ADAPTATION ADATTAMENTO MOTORE - TRASMISSIONE			Qte-Menge-Cant-Qty-Q.ta										4 AA 8009									
	Rep Hinw Fig Item Rif	Número Teil-Nr Numero Part-Nr Part-Nr	Désignation Bezeichnung Descripcion Description Descrizione	1	2	3	4	5	6	7	8	9	10	11	12	13	14	15	16	17	18	19	20
35	205205	Raccord Union Racor Raccordo	- Verschraubung - Connection	5	5	5	5					5	5	5	5								
36	203617	Demi-collier Media abrazadera Fascetta	- Halb-klemme - Half-clamp	2	2	2	2					2	2	2	2								
37	177878	Demi-collier Media abrazadera Fascetta	- Halb-klemme - Half-clamp	8	8	8	8					8	8	8	8								
38	58530	Vis H,M 8-45-8.8-ZN8/C Tornillo Vite	- Schraube - Screw	4	4	4	4					4	4	4	4								
39	168861	Plaque de protection Placa de protección Piastra di protezione	- Schützplatte - Protection plate	2	2	2	2					2	2	2	2								
40	168858	Plaque de protection Placa de protección Piastra di protezione	- Schützplatte - Protection plate	2	2	2	2					2	2	2	2								
42	51300572	Tige Vástago Stelo	- Stange - Rod M6-1x60 All Thread	4	4	4	4					4	4	4	4								
43	162229	Ecrou H,FR M 6 C 8ZN.C Tuerca Dado	- Mutter - Nut	2	2	2	2					2	2	2	2								
44	25714	Ecrou H ,M 6 ZN Tuerca Dado	- Mutter - Nut	2	2	2	2					2	2	2	2								
45	29469	Rondelle M 6 ZN Arandela Rondella	- Unterlegscheibe - Washer	4	4	4	4					4	4	4	4								
46	168856	Demi-collier Media abrazadera Fascetta	- Halb-klemme - Half-clamp	2	2	2	2					2	2	2	2								

M

+

Catalogue : 647483

5	ADAPTATION MOTEUR-TRANSMISSION MOTOR-GETRIEBE ANPASSUNG ADAPTACION MOTOR-TRANSMISION ENGINE-TRANSMISSION ADAPTATION ADATTAMENTO MOTORE - TRASMISSIONE			Qte-Menge-Cant-Qty-Q.ta										4 AA 8009									
	Rep Hinw Fig Item Rif	Numéro Teil-Nr Numero Part-Nr Part-Nr	Désignation Bezeichnung Descripcion Description Descrizione	1	2	3	4	5	6	7	8	9	10	11	12	13	14	15	16	17	18	19	20
47	61674	Rondelle M 8 ZN Arandela Rondella	- Unterlegscheibe - Washer	6	6	6	6					6	6	6	6								
48	58528	Ecrou H ,M 8 ZN Tuerca Dado	- Mutter - Nut	6	6	6	6					6	6	6	6								
49	169372	Joint torique Junta torica Anello OR	- "O" ring - "O" ring	X	X	X	X					X	X	X	X								
50	190017	Joint torique Junta torica Anello OR	- "O" ring - "O" ring	X	X	X	X					X	X	X	X								
51	48905	Joint torique Junta torica Anello OR	- "O" ring - "O" ring	X	X	X	X					X	X	X	X								
52	184787	Joint torique Junta torica Anello OR	- "O" ring "O" ring	X	X	X	X					X	X	X	X								
53	190878	Joint torique Junta torica Anello OR	- "O" ring "O" ring	X	X	X	X					X	X	X	X								
54	177638	Joint torique Junta torica Anello OR	- "O" ring - "O" ring	X	X	X	X					X	X	X	X								

M

4 AA 8010

ADAPTATION MOTEUR-TRANSMISSION
MOTOR-GETRIEBE ANPASSUNG
ADAPTACION MOTOR-TRANSMISION
ENGINE-TRANSMISSION ADAPTATION
ADATTAMENTO MOTORE - TRASMISSIONE

M 40-2/4 ST3B M 40-2/4H ST3B
M 50-2/4 ST3B M 50-2/4H ST3B

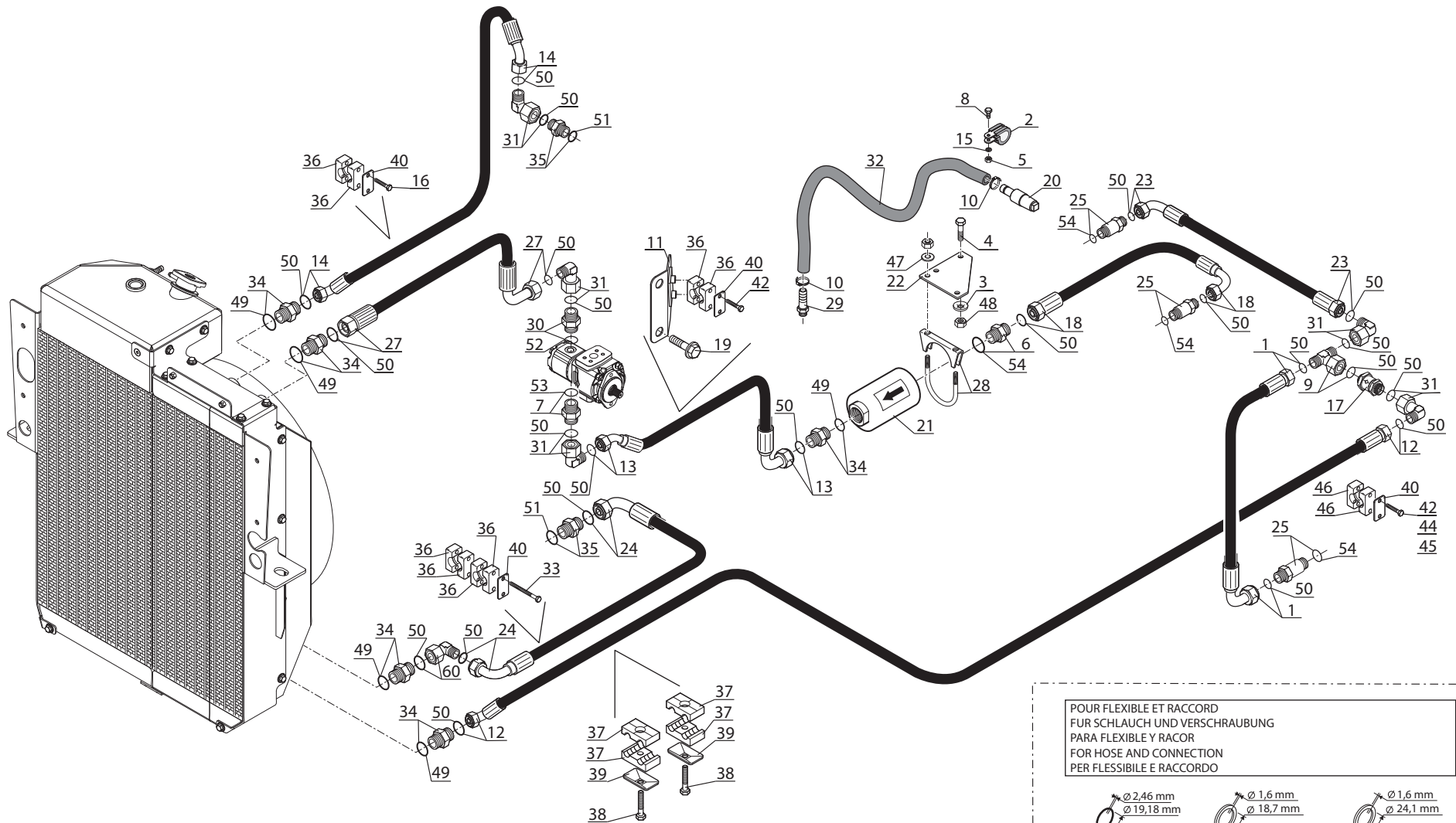

POUR FLEXIBLE ET RACCORD
FÜR SCHLAUCH UND VERSCHRAUBUNG
PARA FLEXIBLE Y RACOR
FOR HOSE AND CONNECTION
PER FLESSIBILE E RACCORDO

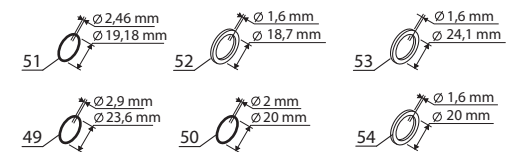

Catalogue : 647483

1	ADAPTATION MOTEUR-TRANSMISSION MOTOR-GETRIEBE ANPASSUNG ADAPTACION MOTOR-TRANSMISION ENGINE-TRANSMISSION ADAPTATION ADATTAMENTO MOTORE - TRASMISSIONE			Qte-Menge-Cant-Qty-Q.ta										4 AA 8010									
	Rep Hinw Fig Item Rif	Numéro Teil-Nr Numero Part-Nr Part-Nr	Désignation Bezeichnung Descripcion Description Descrizione	1	2	3	4	5	6	7	8	9	10	11	12	13	14	15	16	17	18	19	20
1	239274	Flexible (Lg 400) Flexible Flessibile	- Schlauch - Hose					1	1	1	1					1	1	1	1				
2	86505	Collier Abrazadera Fascetta	- Spannschelle - Clamp					1	1	1	1					1	1	1	1				
3	63351	Rondelle JZC8CAD.BICH Arandela Rondella	- Unterlegscheibe - Washer					2	2	2	2					2	2	2	2				
4	57446	Rondelle M 8 ZN Arandela Rondella	- Unterlegscheibe - Washer					2	2	2	2					2	2	2	2				
5	54232	Ecrou H ,M 5 ZN Tuerca Dado	- Mutter - Nut					1	1	1	1					1	1	1	1				
6	524789	Raccord Union Racor Raccordo	- Verschraubung - Connection					1	1	1	1					1	1	1	1				
7	524788	Raccord Union Racor Raccordo	- Verschraubung - Connection					1	1	1	1					1	1	1	1				
8	54230	Vis H,M 5- 16-8.8-ZN5/C Tornillo Vite	- Schraube - Screw					1	1	1	1					1	1	1	1				
9	239197	Raccord Té Racor Raccordo	- Verschraubung - Connection					1	1	1	1					1	1	1	1				
10	31468	Collier Abrazadera Fascetta	- Spannschelle - Clamp					2	2	2	2					2	2	2	2				
11	51300445	Support bride Soporte brida Supporto flangia	- Flansch träger - Flange bracket					3	3	3	3					3	3	3	3				

M

+

Catalogue : 647483

2	ADAPTATION MOTEUR-TRANSMISSION MOTOR-GETRIEBE ANPASSUNG ADAPTACION MOTOR-TRANSMISION ENGINE-TRANSMISSION ADAPTATION ADATTAMENTO MOTORE - TRASMISSIONE		Qte-Menge-Cant-Qty-Q.ta										4 AA 8010										
	Rep Hinw Fig Item Rif	Número Teil-Nr Numero Part-Nr Part-Nr	Désignation Bezeichnung Descripcion Description Descrizione	1	2	3	4	5	6	7	8	9	10	11	12	13	14	15	16	17	18	19	20
12	306443	Flexible (Lg 1260) Flexible Flessibile	- Schlauch - Hose					1	1	1	1					1	1	1	1				
13	302020	Flexible (Lg 1260) Flexible Flessibile	- Schlauch - Hose					1	1	1	1					1	1	1	1				
14	302017	Flexible (Lg 1675) Flexible Flessibile	- Schlauch - Hose					1	1	1	1					1	1	1	1				
15	29483	Rondelle W 5 ZN Arandela Rondella	- Unterlegscheibe - Washer					1	1	1	1					1	1	1	1				
16	29481	Vis H,M 6- 45-8.8-ZN5/C Tornillo Vite	- Schraube - Screw					2	2	2	2					2	2	2	2				
17	264882	Clapet Válvula Valvola	- Klappe - Valve					1	1	1	1					1	1	1	1				
18	233726	Flexible (Lg 2210) Flexible Flessibile	- Schlauch - Hose					1	1	1	1					1	1	1	1				
19	259710	Vis H EMB M12-25 8.8DIN6921 Tornillo Vite	- Schraube - Screw					2	2	2	2					2	2	2	2				
20	254733	Raccord Union Cranté Racor Raccordo	- Verschraubung - Connection					1	1	1	1					1	1	1	1				
21	254582	Filtre Filtro Filtro	- Filter - Filter					1	1	1	1					1	1	1	1				
22	254578	Support Soporte Supporto	- Träger - Bracket					1	1	1	1					1	1	1	1				

M

+

Catalogue : 647483

Rep Hinw Fig Item Rif	Numéro Teil-Nr Numero Part-Nr Part-Nr	Désignation Bezeichnung Descripcion Description Descrizione	Qte-Menge-Cant-Qty-Q.ta										4 AA 8010									
			1- M26- 2 ST3B					11 - M30- 2H ST3B					2- M26- 4 ST3B					12 - M30- 4H ST3B				
			3- M30- 2 ST3B					13 - M40- 2H ST3B					4- M30- 4 ST3B					14 - M40- 4H ST3B				
5- M40- 2 ST3B					15 - M50- 2H ST3B					6- M40- 4 ST3B					16 - M50- 4H ST3B							
7- M50- 2 ST3B					17 -					8- M50- 4 ST3B					18 -							
9- M26- 2H ST3B					19 -					10-M26- 4H ST3B					20 -							
1	2	3	4	5	6	7	8	9	10	11	12	13	14	15	16	17	18	19	20			
23	254510	Flexible (Lg 450) Flexible Flessibile	- Schlauch - Hose	1	1	1	1					1	1	1	1							
24	234274	Flexible Flexible Flessibile	-Schlauch - Hose		1	1	1	1				1	1	1	1							
25	233728	Raccord Union Prolongateur Racor Raccordo	- Verschraubung - Connection		3	3	3	3				3	3	3	3							
27	305140	Flexible (Lg 750) Flexible Flessibile	- Schlauch - Hose		1	1	1	1				1	1	1	1							
28	224928	Collier Abrazadera Fascetta	- Spannschelle - Clamp		1	1	1	1				1	1	1	1							
29	222381	Reniflard Respiradero Sfiato	- Entlüftung - Air breather		1	1	1	1				1	1	1	1							
30	218884	Raccord Union Racor Raccordo	- Verschraubung - Connection		1	1	1	1				1	1	1	1							
31	217044	Racc Coudé 90° Adap. Racor Raccordo	- Verschraubung - Connection		6	6	6	6				6	6	6	6							
32	211954	Durit (Lg 800) Tubo flexible Manicotto	- Schlauch - Hose		1	1	1	1				1	1	1	1							
33	205933	Vis H,M 6-90-8.8-ZN5/C Tornillo Vite	- Schraube - Screw		2	2	2	2				2	2	2	2							
34	205206	Raccord Union Racor Raccordo	- Verschraubung - Connection		5	5	5	5				5	5	5	5							

M

+

Catalogue : 647483

4	ADAPTATION MOTEUR-TRANSMISSION MOTOR-GETRIEBE ANPASSUNG ADAPTACION MOTOR-TRANSMISION ENGINE-TRANSMISSION ADAPTATION ADATTAMENTO MOTORE - TRASMISSIONE			Qte-Menge-Cant-Qty-Q.ta										4 AA 8010									
	Rep Hinw Fig Item Rif	Número Teil-Nr Numero Part-Nr Part-Nr	Désignation Bezeichnung Descripcion Description Descrizione	1	2	3	4	5	6	7	8	9	10	11	12	13	14	15	16	17	18	19	20
35	205205	Raccord Union Racor Raccordo	- Verschraubung - Connection					2	2	2	2					2	2	2	2				
36	203617	Demi-collier Media abrazadera Fascetta	- Halb-klemme - Half-clamp					8	8	8	8					8	8	8	8				
37	177878	Demi-collier Media abrazadera Fascetta	- Halb-klemme - Half-clamp					4	4	4	4					4	4	4	4				
38	58530	Vis H,M 8- 45-8.8-ZN8/C Tornillo Vite	- Schraube - Screw					2	2	2	2					2	2	2	2				
39	168861	Plaque de protection Placa de protección Piastra di protezione	- Schützplatte - Protection plate					2	2	2	2					2	2	2	2				
40	168858	Plaque de protection Placa de protección Piastra di protezione	- Schützplatte - Protection plate					4	4	4	4					4	4	4	4				
42	51300572	Tige Vástago Stelo	- Stange - Rod M6-1x60 AllThread					4	4	4	4					4	4	4	4				
43	162229	Ecrou H,FR M 6 C 8 ZNC Tuerca Dado	- Mutter - Nut					2	2	2	2					2	2	2	2				
44	25714	Ecrou H ,M 6 ZN Tuerca Dado	- Mutter - Nut					2	2	2	2					2	2	2	2				
45	29469	Rondelle M 6 ZN Arandela Rondella	- Unterlegscheibe - Washer					4	4	4	4					4	4	4	4				
46	168856	Demi-collier Media abrazadera Fascetta	- Halb-klemme - Half-clamp					2	2	2	2					2	2	2	2				

M

+

Catalogue : 647483

5	ADAPTATION MOTEUR-TRANSMISSION MOTOR-GETRIEBE ANPASSUNG ADAPTACION MOTOR-TRANSMISION ENGINE-TRANSMISSION ADAPTATION ADATTAMENTO MOTORE - TRASMISSIONE			Qte-Menge-Cant-Qty-Q.ta										4 AA 8010									
	Rep Hinw Fig Item Rif	Numéro Teil-Nr Numero Part-Nr Part-Nr	Désignation Bezeichnung Descripcion Description Descrizione	1	2	3	4	5	6	7	8	9	10	11	12	13	14	15	16	17	18	19	20
47	61674	Rondelle M 8 ZN Arandela Rondella	- Unterlegscheibe - Washer					6	6	6	6					6	6	6	6				
48	58528	Ecrou H ,M 8 ZN Tuerca Dado	- Mutter - Nut					2	2	2	2					2	2	2	2				
49	169372	Joint torique Junta torica Anello OR	- "O" ring - "O" ring					X	X	X	X					X	X	X	X				
50	190017	Joint torique Junta torica Anello OR	- "O" ring - "O" ring					X	X	X	X					X	X	X	X				
51	48905	Joint torique Junta torica Anello OR	- "O" ring - "O" ring					X	X	X	X					X	X	X	X				
52	184787	Joint torique Junta torica Anello OR	- "O" ring - "O" ring					X	X	X	X					X	X	X	X				
53	190878	Joint torique Junta torica Anello OR	- "O" ring - "O" ring					X	X	X	X					X	X	X	X				
54	177638	Joint torique Junta torica Anello OR	- "O" ring - "O" ring					X	X	X	X					X	X	X	X				

M

4 AB 8054

TRANSMISSION HYDROSTATIQUE
HYDROSTATISCHE GETRIEBE
TRANSMISION IDROSTATICA
HYDROSTATIC TRANSMISSION
TRASMISSIONE IDROSTATICA

26-2/4H ST3B
30-2/4H ST3B
40-2/4H ST3B
50-2/4H ST3B

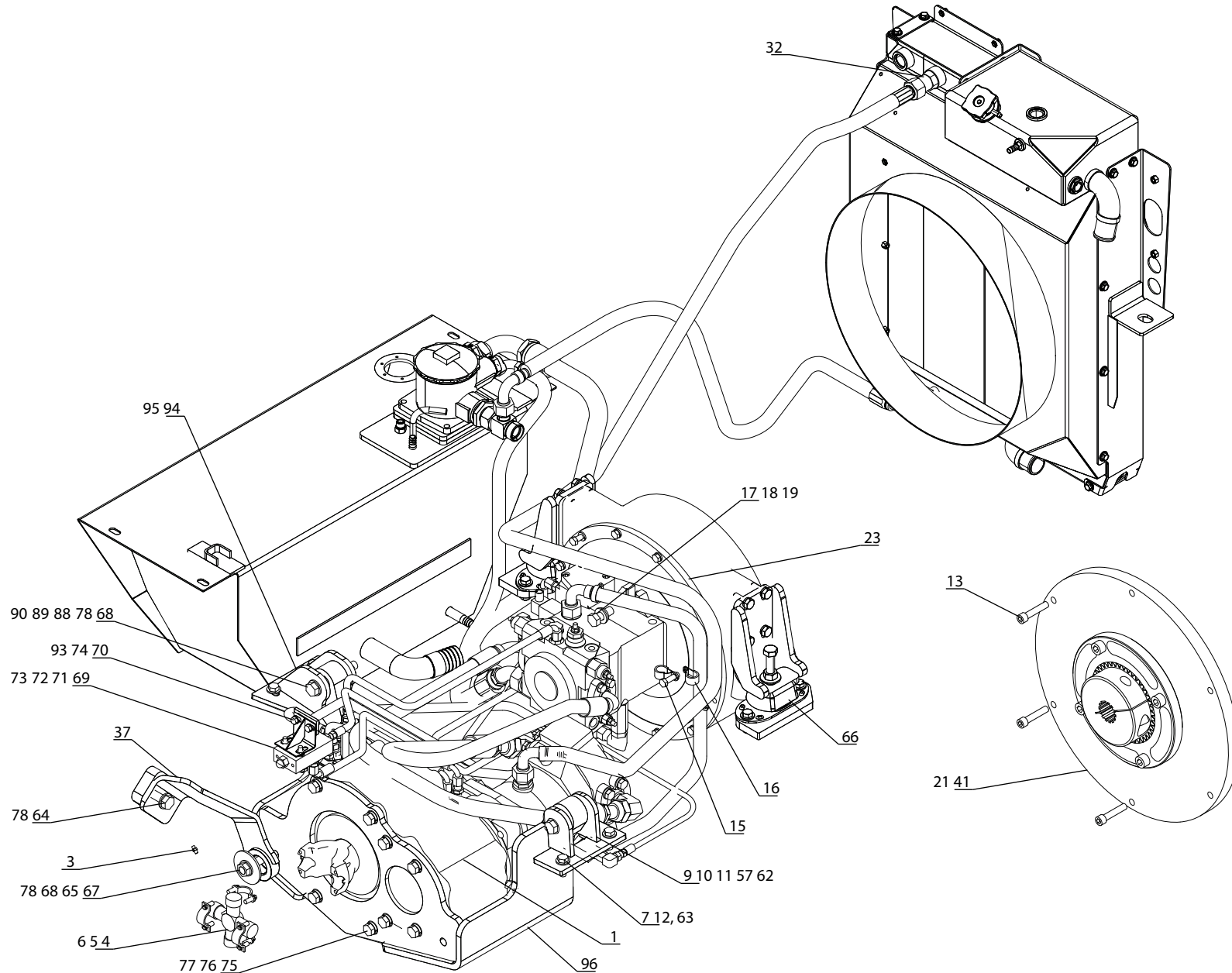

Catalogue : 647483

4 AB 8054

M

Rep Hinw Fig Item Rif	Numéro Teil-Nr Numero Part-Nr Part-Nr	Désignation Bezeichnung Descripcion Description Descrizione	Qte-Menge-Cant-Qty-Q.ta																			
			1	2	3	4	5	6	7	8	9	10	11	12	13	14	15	16	17	18	19	20
1		TRANSMISSION HYDROSTATIQUE HYDROSTATISCHE GETRIEBE TRANSMISION HYDROSTATICA HYDROSTATIC TRANSMISSION TRASMISSIONE IDROSTATICA																				
1	226148	Boîte de vitesse complète Caja de velocidades completo Scàtola del cambio complete	- Kompletter getriebekasten - Drop Box Assy, 2 Sp H 10k									1	1	1	1	1	1	1				
3	162809	Graisseur Greaser Ingrassatore	- Schmiernippel - Engrasador									1	1	1	1	1	1	1				
4	109752	Vis Bolt, 5/16-24 Flange Vite	- Schraube - Tornillo									4	4	4	4	4	4	4				
5	109751	Patte de fixation Fixation Flange 3-70-89 Dana Spicer Flangia di fissaggio	- Befestigung auge - Brida de fijación									2	2	2	2	2	2	2				
6	424647	Croisillon Splice, U-Joint Crocera	- Kardangelenk - Cruzeta									1	1	1	1	1	1	1				
7	61676	Rondelle Washer, M12 Plated Flat Rondella	- Unterlegscheibe - Arandela									4	4	4	4	4	4	4				
9	KN630091	Rondelle Washer, M16 Hardened Zinc Rondella	- Unterlegscheibe - Arandela									4	4	4	4	4	4	4				
10	KN630361	Rondelle Washer, M16 Internal Tooth Lk Rondella	- Unterlegscheibe - Arandela									8	8	8	8	8	8	8				
11	61308	Vis Bolt, M16-2.0 X 50 Vite	- Schraube - Tornillo									4	4	4	4	4	4	4				
12	58546	Vis Bolt H/M12-35/35-8.8-zn8/C Vite	- Schraube - Tornillo									4	4	4	4	4	4	4				
13	K302211	Vis Screw, 5/16-18 X 1-1/4 Soc Hd Vite	- Schraube - Tornillo									6	6	6	6	6	6	6				

+

Catalogue : 647483

2	TRANSMISSION HYDROSTATIQUE HYDROSTATISCHE GETRIEBE TRANSMISION IDROSTATICA HYDROSTATIC TRANSMISSION TRASMISSIONE IDROSTATICA			Qte-Menge-Cant-Qty-Q.ta																4 AB 8054			
	Rep Hinw Fig Item Rif	Numéro Teil-Nr Numero Part-Nr Part-Nr	Désignation Bezeichnung Descripcion Description Descrizione	1	2	3	4	5	6	7	8	9	10	11	12	13	14	15	16	17	18	19	20
15	168351	Vis Bolt Hex M10-35/35 8.8 ZN8/C Vite	- Schraube - Tornillo									20	20	20	20	20	20	20	20				
16	B3698-17	Collier Clamp, 1-1/4 Fascetta	- Spansschelle - Abrazadera									2	2	2	2	2	2	2	2				
17	42818	Vis Bolt, M16-2.0 X 40 Plated Hex Vite	- Schraube - Tornillo									2	2	2	2	2	2	2	2				
18	62203	Rondelle Washer Rondella	- Unterlegscheibe - Arandela									2	2	2	2	2	2	2	2				
19	42322	Rondelle Washer M16 Unterlegscheibe	- Unterlegscheibe - Rondelle									2	2	2	2	2	2	2	2				
21	805677	Manchon Hydrastatic Coupling Manicotto	- Kupplungsmuffe - Manguito									1	1	1	1	1	1	1	1				
23	508802	Couvercle Cover Coperchio	- Deckel - Tapadera									1	1	1	1	1	1	1	1				
32	R18147-5	Connecteur Connector, Parker 12-10-F5010 Connettore	- Verbinder - Conector									2	2	2	2	2	2	2	2				
41	K97615	Anneau Ring, 1 IN Internal Retaining Anello	- Ring - Anillo									1	1	1	1	1	1	1	1				
49	51300805	Entretoise Brace Assy Braccio Assy	- Klammer - Abrazadera									1	1	1	1	1	1	1	1				
57	51300809	Motage Assy Mount Assy LH M30 Montaggio	- Montage Assy. - Montage									1	1	1	1								

M

+

Catalogue : 647483

3	TRANSMISSION HYDROSTATIQUE HYDROSTATISCHE GETRIEBE TRANSMISION IDROSTATICA HYDROSTATIC TRANSMISSION TRASMISSIONE IDROSTATICA			Qte-Menge-Cant-Qty-Q.ta										4 AB 8054									
	Rep Hinw Fig Item Rif	Numéro Teil-Nr Numero Part-Nr Part-Nr	Désignation Bezeichnung Descripcion Description Descrizione	1	2	3	4	5	6	7	8	9	10	11	12	13	14	15	16	17	18	19	20
62	51300870	Motage Assy Mount Assy LH M50 Montaggio	- Montage Assy. - Montage															1	1	1	1		
63	77710	Rondelle Washer -HR 12.5X27 X 2.5 ZN12A/CR3 Rondella	- Unterlegscheibe - Arandela									4	4	4	4	4	4	4	4				
64	217186	Vis Bolt Vite	- Schraube - Tornillo									1	1	1	1	1	1	1	1				
65	168366	Vis Screw Vite	- Schraube - Tornillo									1	1	1	1	1	1	1	1				
66	235574	Silentbloc Absorber Tasselo	- Dampfer - Amortiguador									1	1	1	1	1	1	1	1				
67	57045	Rondelle Washer, 17 70 4 Zn12c Rondella	- Unterlegscheibe - Arandela									1	1	1	1	1	1	1	1				
68	171460	Ecrou Nut, M16-2.0 Plated Self Lock Dado	- Mutter - Tuerca									3	3	3	3	3	3	3	3				
69	75498	Ensemble de soupapes Valve Assy, Inching Th7 Gruppo Valvola	- Ventilbaugruppe - Ensamble de Valvula									1	1	1	1	1	1	1	1				
70	61674	Rondelle Washer M 8 ZN12C/FE Rondella	- Unterlegscheibe - Arandela									4	4	4	4	4	4	4	4				
71	58531	Vis Bolt Vite	- Schraube - Tornillo									2	2	2	2	2	2	2	2				
72	42325	Rondelle Washer, M8 Plated Lock Rondella	- Unterlegscheibe - Arandela									2	2	2	2	2	2	2	2				

M

+

Catalogue : 647483

4	TRANSMISSION HYDROSTATIQUE HYDROSTATISCHE GETRIEBE TRANSMISION IDROSTATICA HYDROSTATIC TRANSMISSION TRASMISSIONE IDROSTATICA			Qte-Menge-Cant-Qty-Q.ta																4 AB 8054				
	Rep Hinw Fig Item Rif	Numéro Teil-Nr Numero Part-Nr Part-Nr	Désignation Bezeichnung Descripcion Description Descrizione	1	2	3	4	5	6	7	8	9	10	11	12	13	14	15	16	17	18	19	20	
73	58528	Ecrou Nut, M8-8 Zn8 Dado	- Mutter - Tuerca									2	2	2	2	2	2	2						
74	57446	Vis Bolt, M8 X 25 Hex Vite	- Schraube - Tornillo									2	2	2	2	2	2	2						
75	61680	Rondelle Washer, M14n Flat Rondella	- Unterlegscheibe - Arandela									8	8	8	8	8	8	8						
76	42256	Rondelle Washer, M14 Lock Rondella	- Unterlegscheibe - Arandela									8	8	8	8	8	8	8						
77	58557	Vis Screw, M14-2 X 40 Hex Head Vite	- Schraube - Tornillo									8	8	8	8	8	8	8						
78	194287	Rondelle Washer, M16 160hv Zn12c/Fe Unterlegscheibe	- Unterlegscheibe - Rondelle									6	6	6	6	6	6	6						
88	235573	Silentbloc Absorber Tasselo	- Dampfer - Amortiguador									2	2	2	2	2	2	2						
89	167409	Vis Bolt Vite	- Schraube - Tornillo									2	2	2	2	2	2	2						
90	235572	Rondelle Washer Rondella	- Unterlegscheibe - Arandela									4	4	4	4	4	4	4						
93	51300819	Support Support TH7 Supporto	- Träger - Soporte									1	1	1	1	1	1	1						
94	51300812	Motage Assy Mount Assy RH M30 Montaggio	- Motage Assy - Montage									1	1	1	1									

M

+

Catalogue : 647483

5	TRANSMISSION HYDROSTATIQUE HYDROSTATISCHE GETRIEBE TRANSMISION HYDROSTATICA HYDROSTATIC TRANSMISSION TRASMISSIONE IDROSTATICA			Qte-Menge-Cant-Qty-Q.ta																	4 AB 8054				M			
	Rep Hinw Fig Item Rif	Número Teil-Nr Numero Part-Nr Part-Nr	Désignation Bezeichnung Descripcion Description Descrizione	1	2	3	4	5	6	7	8	9	10	11	12	13	14	15	16	17	18	19	20					
95	51300872	Motage Assy Mount Assy RH M50 Montaggio	- Motage Assy - Montage																1	1	1	1						
96	51300794	Support boîte de vitesses avant droit Gearbox Mount delantero derecho destro	- Träger Getriebe vorn rechts - Soporte caja de velocidades - Supporto cambio anteriore										1	1	1	1	1	1	1									

4 AB 8055

TRANSMISSION HYDROSTATIQUE
HYDROSTATISCHE GETRIEBE
TRANSMISION HYDROSTATICA
HYDROSTATIC TRANSMISSION
TRASMISSIONE IDROSTATICA

26-2/4H ST3B
30-2/4H ST3B
40-2/4H ST3B
50-4/4H ST3B

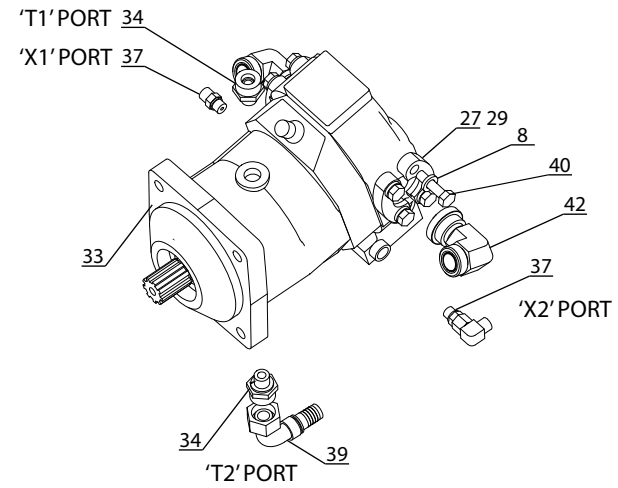
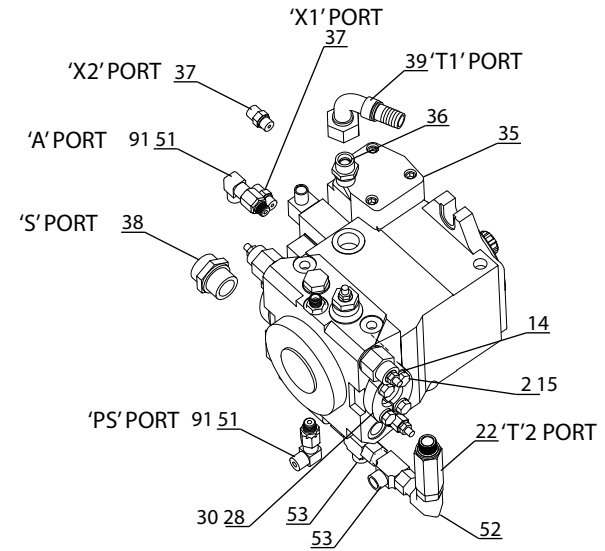
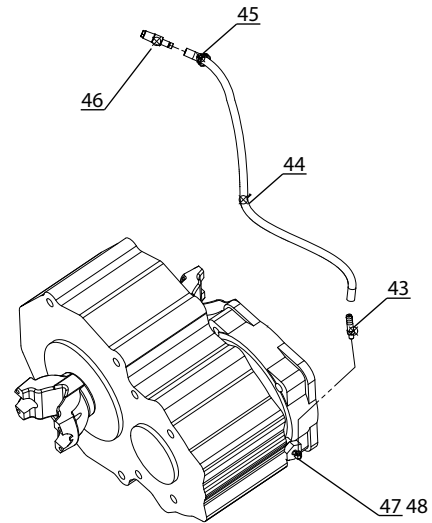
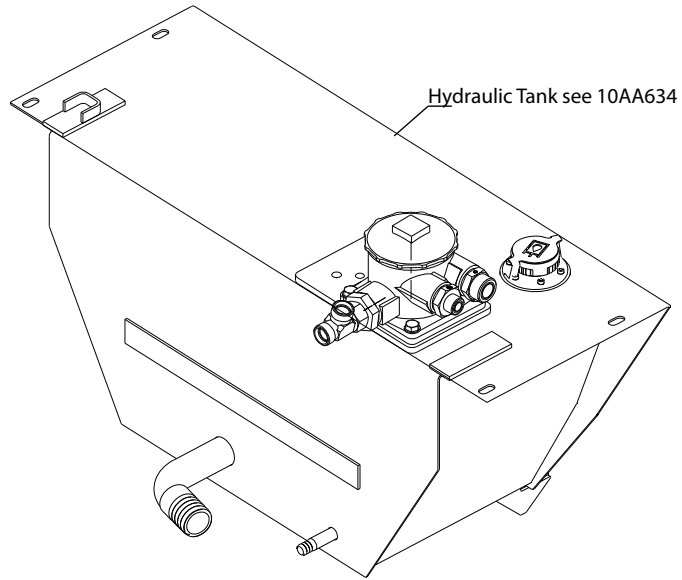

Catalogue : 647483

1	TRANSMISSION HYDROSTATIQUE HYDROSTATISCHE GETRIEBE TRANSMISION HYDROSTATICA HYDROSTATIC TRANSMISSION TRASMISSIONE IDROSTATICA			Qte-Menge-Cant-Qty-Q.ta																4 AB 8055				M			
	Rep Hinw Fig Item Rif	Numéro Teil-Nr Numero Part-Nr Part-Nr	Désignation Bezeichnung Descripcion Description Descrizione	1	2	3	4	5	6	7	8	9	10	11	12	13	14	15	16	17	18	19	20				
8	42231	Rondelle Washer.w 12 Zn12a/Fe/Cr3/I-bdm-008 Rondella	- Unterlegscheibe - Arandela										12	12	12	12	12	12	12								
14	42232	Rondelle Washer M10 Zn12a/Fe/Cr3/I-bdm-008 Rondella	- Unterlegscheibe - Arandela										20	20	20	20	20	20	20								
22	803886	Valve Valve, 3 Bar Check Valvola	- Valve - Valvula										1	1	1	1	1	1	1								
27	803611	Joint d'étanchéité Seal, #16 Code 62 Guarnizione	- Dichtungsring - Junta de estanqueidad										2	2	2	2	2	2	2								
28	803566	Bride Split Flange - 12 Flangia	- Träger - Brida										4	4	4	4	4	4	4								
29	803570	Bride Split Flange - 16 Flangia	- Träger - Brida										2	2	2	2	2	2	2								
30	803585	Joint d'étanchéité Seal, #12 Code 62 Guarnizione	- Dichtungsring - Junta de estanqueidad										2	2	2	2	2	2	2								
33	208701	Moteur hydrostatique Hydrostatic Motor Idrostatica Motore	- Hydrostatische Motor - Motor Hidrostatico										1	1	1	1	1	1	1								
34	234267	Raccord Union Union Raccordo	- Verschraubung - Racor										2	2	2	2	2	2	2								
35	814802	Pompe Hydrostatique Pump, Hydrostatic M T3 Pompa Idrostatica	- Hydrostatische Pumpe - Pompa Hidrostatica										1	1	1	1	1	1	1								
36	524789	Raccord Fitting Racordo	- Verschraubung - Racor										1	1	1	1	1	1	1								

+

Catalogue : 647483

2	TRANSMISSION HYDROSTATIQUE HYDROSTATISCHE GETRIEBE TRANSMISION IDROSTATICA HYDROSTATIC TRANSMISSION TRASMISSIONE IDROSTATICA			Qte-Menge-Cant-Qty-Q.ta										4 AB 8055									
	Rep Hinw Fig Item Rif	Número Teil-Nr Numero Part-Nr Part-Nr	Désignation Bezeichnung Descripcion Description Descrizione	1	2	3	4	5	6	7	8	9	10	11	12	13	14	15	16	17	18	19	20
37	806955	Raccord Fitting, Modified Racordo	- Verschraubung - Racor									4	4	4	4	4	4	4					
38	803270	Raccord Connector, 16m33f82edmlo-S Racordo	- Verschraubung - Racor									1	1	1	1	1	1	1					
39	208561	Raccord Fitting, Cd Crante 20/Fe22 Racordo	- Verschraubung - Racor									2	2	2	2	2	2	2					
40	29475	Vis Bolt, M12-1.75 X 45 Plated Hex Vite	- Schraube - Tornillo									8	8	8	8	8	8	8					
42	807675	Raccord Coude Elbow Racordo	- Verschraubung - Racor									2	2	2	2	2	2	2					
43	254733	Raccord Coude Connector Racordo	- Verschraubung - Racor									1	1	1	1	1	1	1					
44	190441	Durit Hose Manicotto	- Schlauch - Tubo flexible									1	1	1	1	1	1	1					
45	479218	Collier Clamp TG CVM3/ 9/ 08 -16 Fascetta	- Spannschelle - Abrazadera									1	1	1	1	1	1	1					
46	222381	Reniflard Air Breather Sfiato	- Entlüftung - Respiradero									1	1	1	1	1	1	1					
47	812882	Bouchon Plug, Modified Tapped Tappo	- Stopfen - Tapón									1	1	1	1	1	1	1					
48	R18613	Raccord Coude Elbow, 1/8 NPT 90 Deg Street Racordo	- Verschraubung - Racor									1	1	1	1	1	1	1					

M

+

Catalogue : 647483

3	TRANSMISSION HYDROSTATIQUE HYDROSTATISCHE GETRIEBE TRANSMISION HYDROSTATICA HYDROSTATIC TRANSMISSION TRASMISSIONE IDROSTATICA			Qte-Menge-Cant-Qty-Q.ta										4 AB 8055									
	Rep Hinw Fig Item Rif	Número Teil-Nr Numero Part-Nr Part-Nr	Désignation Bezeichnung Descripcion Description Descrizione	1	2	3	4	5	6	7	8	9	10	11	12	13	14	15	16	17	18	19	20
51	805121	Raccord Connector, 6m14f82edmlo-S Racordo	- Verschraubung - Racor									3	3	3	3	3	3	3					
52	R19452-4	Raccord Coude Elbow, Parker 8-10-C5o1o-S Racordo	- Verschraubung - Racor									1	1	1	1	1	1	1	1				
53	R19829-1	Raccord T Tee, Swivel Nut Run Racordo	- Verschraubung T - Racor									2	2	2	2	2	2	2	2				
91	800479	Raccord Coude Elbow Racordo	- Verschraubung - Racor									2	2	2	2	2	2	2	2				
92	803199	Raccord Coude Elbow, Swivel Nut 4 C61o-S Racordo	- Verschraubung - Racor									2	2	2	2	2	2	2	2				

M

4 AB 8056

TRANSMISSION HYDROSTATIQUE
HYDROSTATISCHE GETRIEBE
TRANSMISION HYDROSTATICA
HYDROSTATIC TRANSMISSION
TRASMISSIONE IDROSTATICA

26-2/4H ST3B
30-2/4H ST3B
40-2/4H ST3B
50-4/4H ST3B

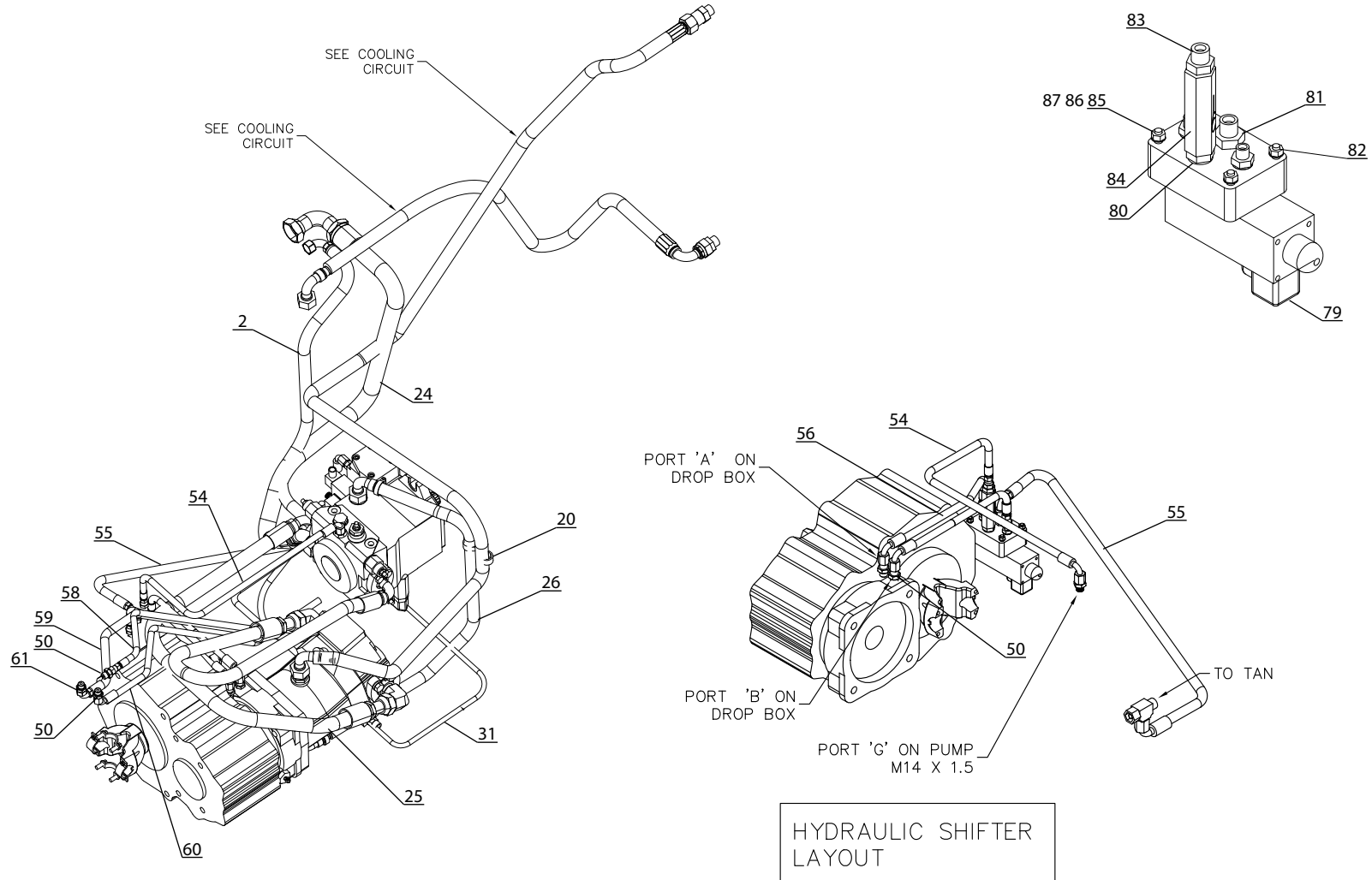

Catalogue : 647483

2	TRANSMISSION HYDROSTATIQUE HYDROSTATISCHE GETRIEBE TRANSMISION IDROSTATICA HYDROSTATIC TRANSMISSION TRASMISSIONE IDROSTATICA			Qte-Menge-Cant-Qty-Q.ta																4 AB 8056				
	Rep Hinw Fig Item Rif	Número Teil-Nr Numero Part-Nr Part-Nr	Désignation Bezeichnung Descripcion Description Descrizione	1	2	3	4	5	6	7	8	9	10	11	12	13	14	15	16	17	18	19	20	
59	51300936	Durit Hose/Hyd -06 x 50in Manicotto	- Schlauch - Tubo flexible									1	1	1	1	1	1	1						
60	51300937	Durit Hose/Hyd -04 x 79in Manicotto	- Schlauch - Tubo flexible									1	1	1	1	1	1	1						
61	812555	Raccord Connector Racordo	- Verschraubung - Racor									1	1	1	1	1	1	1						
79	255333	Electrovalve Electrovalve Elettrovalvola	- Elektroventil - Electroválvula									1	1	1	1	1	1	1						
80	803684	Raccord Connector Racordo	- Verschraubung - Racor									1	1	1	1	1	1	1						
81	803174	Raccord Connector, 6f42edml0-S Racordo	- Verschraubung - Racor									1	1	1	1	1	1	1						
82	803184	Raccord Connector, 4-4f42edml0-S Racordo	- Verschraubung - Racor									2	2	2	2	2	2	2						
83	803196	Raccord Connector, 4-6f42edml0-S Racordo	- Verschraubung - Racor									1	1	1	1	1	1	1						
84	62179	Valve Valve, 2 Speed Valvola	- Valve - Valvula									1	1	1	1	1	1	1						
85	168706	Vis Screw Vite	- Schraube - Tornillo									4	4	4	4	4	4	4						
86	174132	Rondelle Washer, -Jzc 6 6 14-1 Cad.Bi Rondella	- Unterlegscheibe - Arandela									4	4	4	4	4	4	4						

M

+

Catalogue : 647483

3	TRANSMISSION HYDROSTATIQUE HYDROSTATISCHE GETRIEBE TRANSMISION HYDROSTATICA HYDROSTATIC TRANSMISSION TRASMISSIONE IDROSTATICA			Qte-Menge-Cant-Qty-Q.ta																4 AB 8056			
	Rep Hinw Fig Item Rif	Numéro Teil-Nr Numero Part-Nr Part-Nr	Désignation Bezeichnung Descripcion Description Descrizione	1	2	3	4	5	6	7	8	9	10	11	12	13	14	15	16	17	18	19	20
87	25714	Ecrou Nut H,M 6-8-ZN5/C Dado	- Mutter - Tuerca										4	4	4	4	4	4	4				

M

4 AB 8057

REFROIDISSEUR D'HUILE - HYDROSTATIQUE
ÖLKÜHLER - HYDROSTATISCHEN
ENFRIADOR DE ACEITE - HIDROSTATICA
OIL COOLER - HYDROSTATIC
RAFFREDDAMENTO DELL'OLIO - IDROSTATICO

26-2/4H ST3B
30-2/4H ST3B
40-2/4H ST3B
50-4/4H ST3B

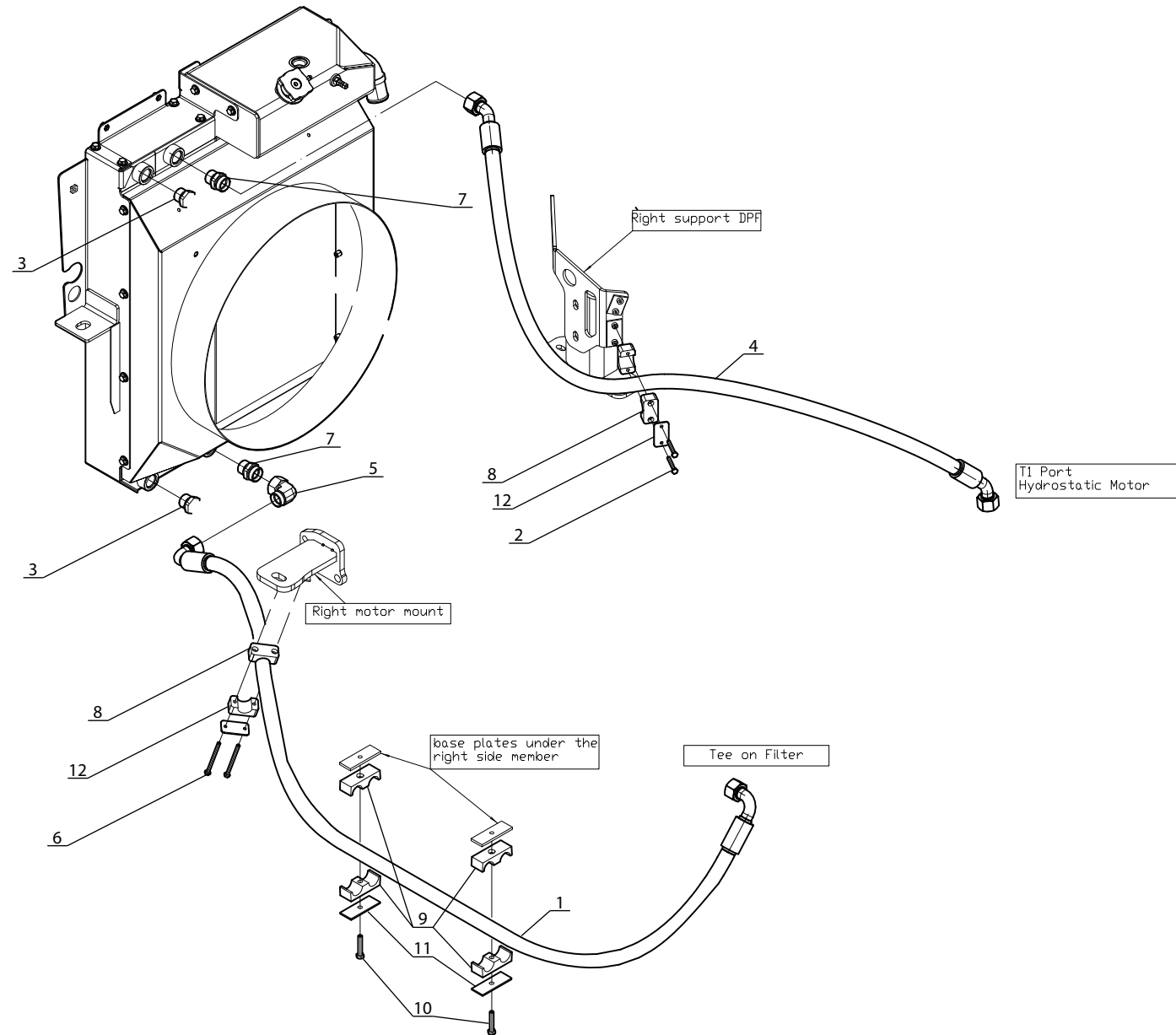

Rep Hinw Fig Item Rif	Numéro Teil-Nr Numero Part-Nr Part-Nr	Désignation Bezeichnung Descripcion Description Descrizione	Qte-Menge-Cant-Qty-Q.ta																	4 AB 8057		M
			1- M26- 2 ST3B 11 - M30- 2H ST3B 2- M26- 4 ST3B 12 - M30- 4H ST3B 3- M30- 2 ST3B 13 - M40- 2H ST3B 4- M30- 4 ST3B 14 - M40- 4H ST3B 5- M40- 2 ST3B 15 - M50- 2H ST3B 6- M40- 4 ST3B 16 - M50- 4H ST3B 7- M50- 2 ST3B 17 - 8- M50- 4 ST3B 18 - 9- M26- 2H ST3B 19 - 10-M26- 4H ST3B 20 -																			
			1	2	3	4	5	6	7	8	9	10	11	12	13	14	15	16	17	18	19	
1	306121	Durit Hose Assy H1s19fc221 Fc22145 L 2210 Manicotto - Schlauch - Tubo flexible								1	1	1	1	1	1	1						
2	29481	Vis Screw, Hex M6-45 Yz Vite - Schraube - Tornillo								2	2	2	2	2	2	2						
3	175744	Bouchon Plug Tappo - Stopfen - Tapón								2	2	2	2	2	2	2						
4	264077	Durit Hose, 90L910 Manicotto - Schlauch - Tubo flexible								1	1	1	1	1	1	1						
5	217044	Raccord Fitting, Cd Ada.Ma221/Fe22 Racordo - Verschraubung - Racor								1	1	1	1	1	1	1						
6	205933	Vis Bolt, M6 -90 Vite - Schraube - Tornillo								2	2	2	2	2	2	2						
7	205206	Raccord Fitting Racordo - Verschraubung - Racor								2	2	2	2	2	2	2						
8	203617	Demi-collier Half Clamp Hr41 20 0/1 Fascetta - Halb-klemme - Media abrazadera								6	6	6	6	6	6	6						
9	177878	Demi-collier Half Clamp Hr4z 28-28 0/1 Fascetta - Halb-klemme - Media abrazadera								4	4	4	4	4	4	4						
10	58530	Vis Bolt, M8-1.25 X 45 Plated Hex Vite - Schraube - Tornillo								2	2	2	2	2	2	2						
11	168861	Collier Clamp Base 4z Fascetta - Spannschelle - Abrazadera								2	2	2	2	2	2	2						

+

Catalogue : 647483

2	REFROIDISSEUR D'HUILE - HYDROSTATIQUE ÖLKÜHLER - HYDROSTATISCHEN ENFRIADOR DE ACEITE - HIDROSTATICA OIL COOLER - HYDROSTATIC RAFFREDDAMENTO DELL'OLIO - IDROSTATICO			Qte-Menge-Cant-Qty-Q.ta																4 AB 8057			
	Rep Hinw Fig Item Rif	Numéro Teil-Nr Numero Part-Nr Part-Nr	Désignation Bezeichnung Descripcion Description Descrizione	1	2	3	4	5	6	7	8	9	10	11	12	13	14	15	16	17	18	19	20
12	168858	Plaque de protection Protection Plate Piastra di protezione	- Schutzplatte - Placa de protección									3	3	3	3	3	3	3					

M

4 AC 8011

CIRCUIT COMBUSTIBLE
BRENNSTOFFKREIS
CIRCUITO COMBUSTIBILE
FUEL CIRCUIT
SISTEMA NAFTA

M 26-2/4 ST3B M 26-2/4H ST3B
M 30-2/4 ST3B M 30-2/4H ST3B
M 40-2/4 ST3B M 40-2/4H ST3B
M 50-2/4 ST3B M 50-2/4H ST3B

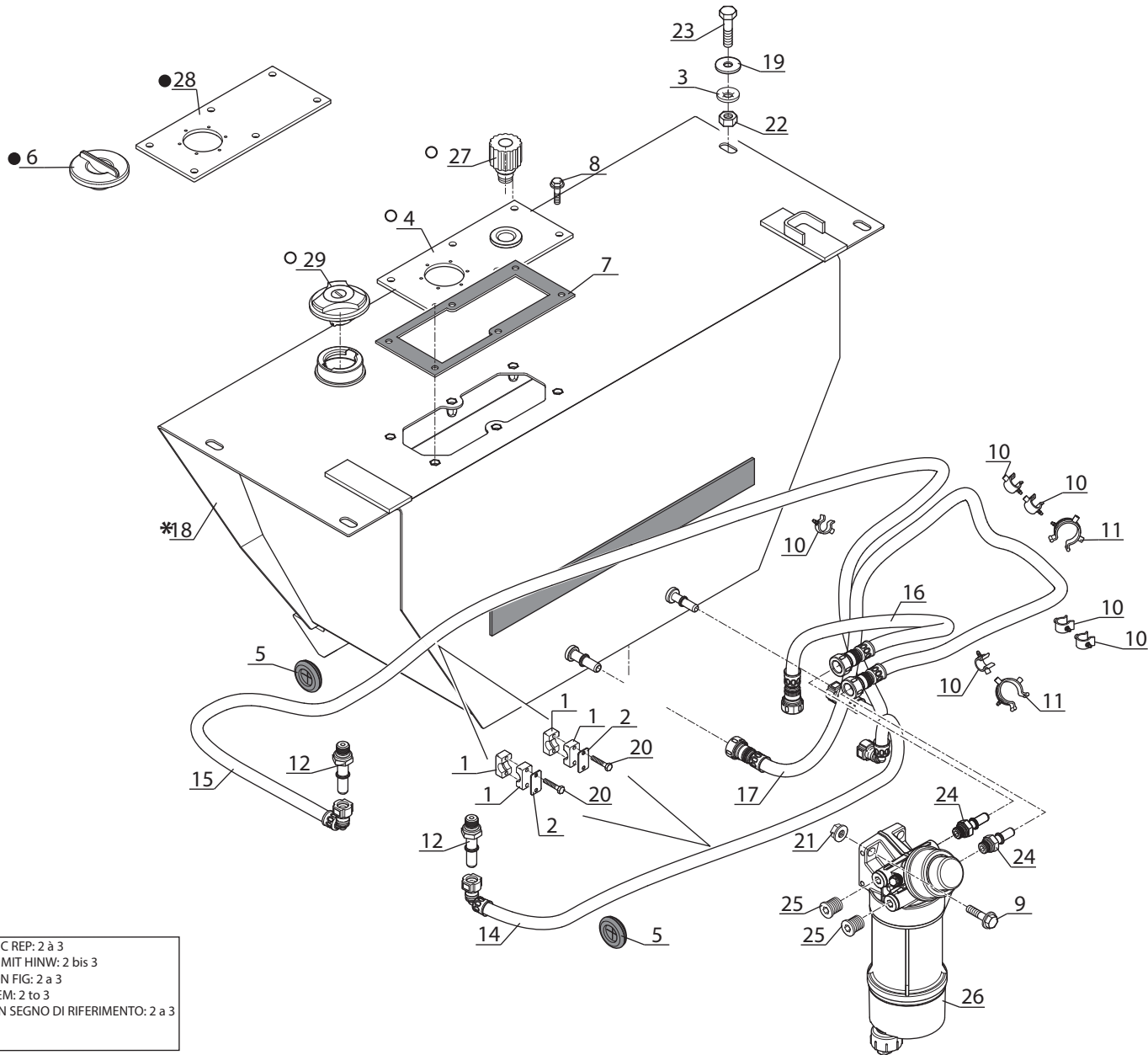

JUSQU'A LA MACHINE
BIS DER MASCHINE
HASTA LA MAQUINA
UP TO MACHINE
FINO LA MACCHINA

● → N°: 796 281

A PARTIR DE LA MACHINE
AB DER MASCHINE
A PARTIR DE LA MAQUINA
FROM MACHINE
A PARTIR DA MACCHINA

○ → N°: 796 282

* RESERVOIR COMPLET AVEC REP: 2 à 3
KOMPLETTER BEHAELTER MIT HINW: 2 bis 3
DEPOSITO COMPLETO CON FIG: 2 a 3
COMPLETE TANK WITH ITEM: 2 to 3
SERBATOIO COMPLETO CON SEGNO DI RIFERIMENTO: 2 a 3

Catalogue : 647483

Rep Hinw Fig Item Rif	Numéro Teil-Nr Numero Part-Nr Part-Nr	Désignation Bezeichnung Descripcion Description Descrizione	Qte-Menge-Cant-Qty-Q.ta										4 AC 8011									
			1- M26- 2 ST3B 2- M26- 4 ST3B 3- M30- 2 ST3B 4- M30- 4 ST3B 5- M40- 2 ST3B 6- M40- 4 ST3B 7- M50- 2 ST3B 8- M50- 4 ST3B 9- M26- 2H ST3B 10-M26- 4H ST3B										11 - M30- 2H ST3B 12 - M30- 4H ST3B 13 - M40- 2H ST3B 14 - M40- 4H ST3B 15 - M50- 2H ST3B 16 - M50- 4H ST3B 17 - 18 - 19 - 20 -									
			1	2	3	4	5	6	7	8	9	10	11	12	13	14	15	16	17	18	19	20
1	168487	Demi-collier Media abrazadera Fascetta	- Halb-klemme - Half-clamp	8	8	8	8	8	8	8	8	8	8	8	8	8						
2	168490	Plaque de protection Placa de protección Piastra di protezione	- Schutzplatte - Protection plate	4	4	4	4	4	4	4	4	4	4	4	4	4						
3	183026	Rondelle JZC10 10,2x26x1,4CAD.BICH Arandela Rondella	- Unterlegscheibe - Washer	4	4	4	4	4	4	4	4	4	4	4	4	4						
4	310460	Trappe de visite Klappe Sludge door	- Kontrolle - Puerta de inspección - Trappola di visita	1	1	1	1	1	1	1	1	1	1	1	1	1						
5	213394	Passe-fil Arandela de gaucho Passo-filo	- Gummischeibe - Cable grommet	2	2	2	2	2	2	2	2	2	2	2	2	2						
6	225200	Bouchon de remplissage Tapón de llenado Tappo di riempimento	- Einfüllverschluss - Filling plug	1	1	1	1	1	1	1	1	1	1	1	1	1						
7	238448	Joint plat Junta plana Guarnizione	- Dichtung - Gasket	1	1	1	1	1	1	1	1	1	1	1	1	1						
8	259601	Vis H EMB M 8-20 8.8 DIN6921 Tornillo Vite	- Schraube - Screw	6	6	6	6	6	6	6	6	6	6	6	6	6						
9	261872	Vis H EMB M10-30 8.8-ZN8/C Tornillo Vite	- Schraube - Screw	2	2	2	2	2	2	2	2	2	2	2	2	2						
10	274184	Collier Abrazadera Fascetta	- Spannschelle - Clamp	7	7	7	7	7	7	7	7	7	7	7	7	7						
11	282755	Collier Abrazadera Fascetta	- Spannschelle - Clamp	2	2	2	2	2	2	2	2	2	2	2	2	2						

M

+

Catalogue : 647483

2	CIRCUIT COMBUSTIBLE BRENNSTOFFKREIS CIRCUITO COMBUSTIBLE FUEL CIRCUIT SISTEMA NAFTA			Qte-Menge-Cant-Qty-Q.ta										4 AC 8011									
	Rep Hinw Fig Item Rif	Número Teil-Nr Numero Part-Nr Part-Nr	Désignation Bezeichnung Descripcion Description Descrizione	1	2	3	4	5	6	7	8	9	10	11	12	13	14	15	16	17	18	19	20
12	295360	Raccord gasoil Racor diesel Raccordo diesel	- Diesel verschraubung - Fitting diesel	2	2	2	2	2	2	2	2	2	2	2	2	2	2	2	2				
14	300545	Flexible (Lg 1050) Flexible Flessibile	- Schlauch - Hose	1	1	1	1	1	1	1	1	1	1	1	1	1	1	1	1				
15	306037	Flexible (Lg 2030) Flexible Flessibile	- Schlauch - Hose	1	1	1	1	1	1	1	1	1	1	1	1	1	1	1	1				
16	302093	Flexible (Lg 680) Flexible Flessibile	- Schlauch - Hose	1	1	1	1	1	1	1	1	1	1	1	1	1	1	1	1				
17	302094	Flexible (Lg 2000) Flexible Flessibile	- Schlauch - Hose	1	1	1	1	1	1	1	1	1	1	1	1	1	1	1	1				
18	302492	Réservoir complet Depósito completo Serbatoio completo	- Kompletter behälter - Complete tank	1	1	1	1	1	1	1	1	1	1	1	1	1	1	1	1				
19	42366	Rondelle SP10,5x 30x3ZN Arandela Rondella	- Unterlegscheibe - Washer	4	4	4	4	4	4	4	4	4	4	4	4	4	4	4	4				
20	54284	Vis H,M 6-35-8.8-ZN5/C Tornillo Vite	- Schraube - Screw	8	8	8	8	8	8	8	8	8	8	8	8	8	8	8	8				
21	260557	Ecrou H EMB M10 C 8 ZN8/C Tuerca Dado	- Mutter - Nut	2	2	2	2	2	2	2	2	2	2	2	2	2	2	2	2				
22	56354	Ecrou H ,M10 zingué Tuerca Dado	- Mutter - Nut	4	4	4	4	4	4	4	4	4	4	4	4	4	4	4	4				
23	63544	Vis H,M10-30-8.8-ZN8/C Tornillo Vite	- Schraube - Screw	4	4	4	4	4	4	4	4	4	4	4	4	4	4	4	4				

M

+

Catalogue : 647483

3	CIRCUIT COMBUSTIBLE BRENNSTOFFKREIS CIRCUITO COMBUSTIBLE FUEL CIRCUIT SISTEMA NAFTA			Qte-Menge-Cant-Qty-Q.ta										4 AC 8011									
	Rep Hinw Fig Item Rif	Número Teil-Nr Numero Part-Nr Part-Nr	Désignation Bezeichnung Descripcion Description Descrizione	1	2	3	4	5	6	7	8	9	10	11	12	13	14	15	16	17	18	19	20
				1- M26- 2 ST3B	11 - M30- 2H ST3B																		
				2- M26- 4 ST3B	12 - M30- 4H ST3B																		
				3- M30- 2 ST3B	13 - M40- 2H ST3B																		
				4- M30- 4 ST3B	14 - M40- 4H ST3B																		
				5- M40- 2 ST3B	15 - M50- 2H ST3B																		
				6- M40- 4 ST3B	16 - M50- 4H ST3B																		
				7- M50- 2 ST3B	17 -																		
				8- M50- 4 ST3B	18 -																		
				9- M26- 2H ST3B	19 -																		
				10-M26- 4H ST3B	20 -																		
24	306344*	Raccord gasoil Racor diesel Raccordo diesel	- Diesel verschraubung - Fitting diesel	2	2	2	2	2	2	2	2	2	2	2	2	2	2	2					
25	306345*	Bouchon Tapón Tappo	- Stopfen - Plug	2	2	2	2	2	2	2	2	2	2	2	2	2	2	2					
26	306346*	Préfiltre à combustible Prefilt a combustible Prefiltro combust.	- Brennstovorfilter - Fuel pre-filter	1	1	1	1	1	1	1	1	1	1	1	1	1	1	1					
27	266219	Reniflard (Rés) Respiradero (Depósito) Sfiato (Serbatoio)	- Entlüftung (Behälter) - Air breather (Tank)	1	1	1	1	1	1	1	1	1	1	1	1	1	1	1					
28	209091	Palatine Platina Piastra	- Anschluse - Delivery Port Connection	1	1	1	1	1	1	1	1	1	1	1	1	1	1	1					
29	266203	Bouchon de remplissage Tapón de llenado Tappo di riempimento * Provided with engine.	- Einfüllverschluss - Filling plug	1	1	1	1	1	1	1	1	1	1	1	1	1	1	1					

M

5 AA 8061

MÂT - DÉPLACEMENT LATÉRAL KIT
MAST - SEITENVERSCHIEBUNG KIT
MASTIL - KIT DE DESPLAZADOR LATERAL
MAST- SIDE SHIFT KIT
MAST - KIT SPOSTAMENTO LATERALE

**M 40-2/4 ST3BM
M 50-4/4 ST3BM**

**40-2/4H ST3B
50-4/4H ST3B**

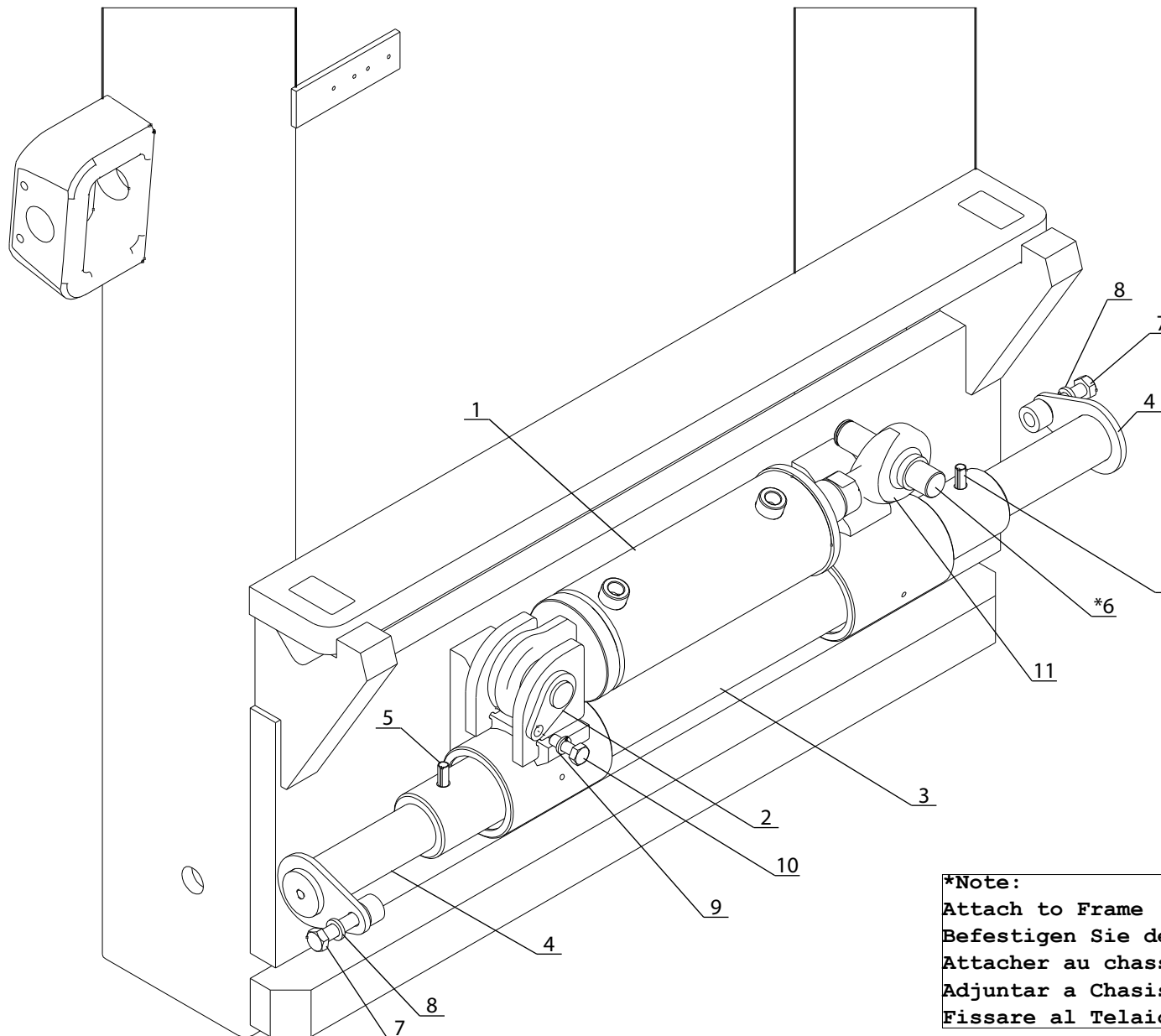

***Note:**
Attach to Frame
Befestigen Sie den Rahmenart
Attacher au chassis
Adjuntar a Chassis
Fissare al Telaio

P.A.O. illus

Catalogue : 647483

1	MÂT - DÉPLACEMENT LATÉRAL KIT MAST - SEITENVERSCHIEBUNG KIT MASTIL - KIT DE DESPLAZADOR LATERAL MAST- SIDE SHIFT KIT MAST - KIT SPOSTAMENTO LATERALE			Qte-Menge-Cant-Qty-Q.ta										5 AA 8061									
	Rep Hinw Fig Item Rif	Numéro Teil-Nr Numero Part-Nr Part-Nr	Désignation Bezeichnung Descripcion Description Descrizione	1	2	3	4	5	6	7	8	9	10	11	12	13	14	15	16	17	18	19	20
1	51300842	Déplacement latéral Cylindre Side Shift Cyl 3B Cilindro di spostamento laterale	- Seitenverschiebung Zylinder - Cilindro de cambio lateral					1	1	1	1					1	1	1	1				
2	51300864	Pin de déplacement latéral Side Shift Pin Pin Spostamento laterale	- Seitenverschiebung Pin - Perno de cambio lateral					1	1	1	1					1	1	1	1				
3	51300881	Arbre de déplacement latéral Side Shift Shaft Albero di spostamento laterale	- Seitenverschiebung Shaft - Eje de cambio lateral					1	1	1	1					1	1	1	1				
4	51300883	Déplacement latéral retenue Pin Side Shift Retain Pin Spostamento laterale Fermo Pin	- Seitenverschiebu Haltestift - Perno de Ret. de cambio lat					2	2	2	2					2	2	2	2				
5	51300888	Goupille Roll Pin .38 x 2.25L Znc Rotolo Pin	- Walzenzapfen - Perno					2	2	2	2					2	2	2	2				
6	51300992	Goupille Pin SS Cyl Rotolo Pin	- Walzenzapfen - Perno					1	1	1	1					1	1	1	1				
7	J29475	Vis Bolt, M12-1.75 X 45 Plated Hex Vite	- Schraube - Tornillo					2	2	2	2					2	2	2	2				
8	J42231	Rondelle Washer.w 12 Zn12a/Fe/Cr3/I-bdm-008 Rondella	- Dichtung - Arandela					2	2	2	2					2	2	2	2				
9	J42232	Rondelle Washer M10 Zn12a/Fe/Cr3/I-bdm-008 Rondella	- Dichtung - Arandela					1	1	1	1					1	1	1	1				
10	J63727	Vis Bolt, M10-1.5 X 20 Plated Hex Vite	- Schraube - Tornillo					1	1	1	1					1	1	1	1				
11	J803734	Tige de fin Rod End Assy Canna finale	- Stange Ende - Barra de acoplamiento					1	1	1	1					1	1	1	1				

M

5 AA 8062

MÂT - DÉPLACEMENT LATÉRAL KIT
MAST - SEITENVERSCHIEBUNG KIT
MASTIL - KIT DE DESPLAZADOR LATERAL
MAST-SIDE SHIFT KIT
MAST - KIT SPOSTAMENTO LATERALE

M 26-2/4 ST3BM
M 30-2/4 ST3BM

26-2/4H ST3B
30-2/4H ST3B

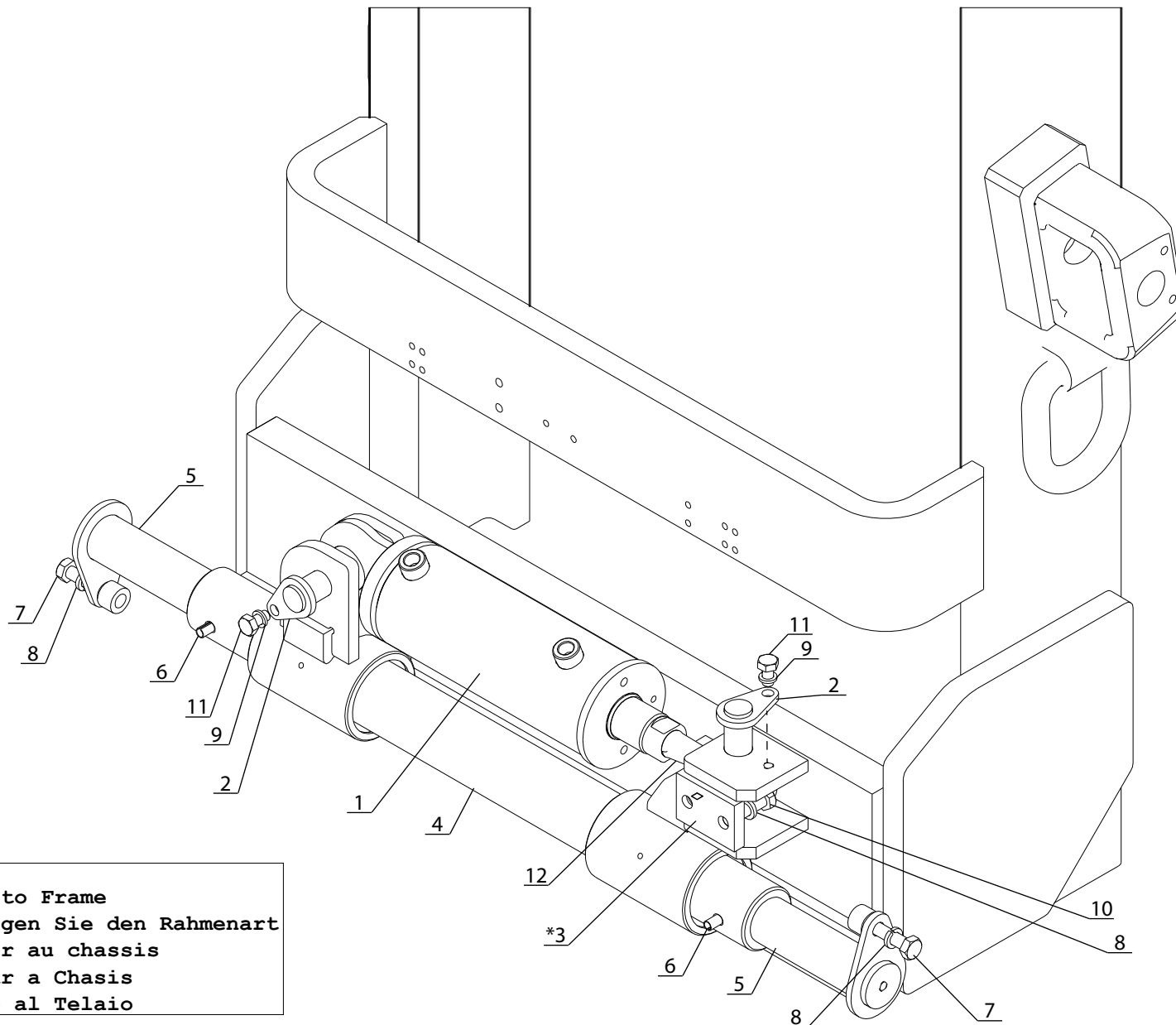

***Note:**
Attach to Frame
Befestigen Sie den Rahmenart
Attacher au chassis
Adjuntar a Chasis
Fissare al Telaio

Catalogue : 647483

1	MÂT - DÉPLACEMENT LATÉRAL KIT MAST - SEITENVERSCHIEBUNG KIT MASTIL - KIT DE DESPLAZADOR LATERAL MAST- SIDE SHIFT KIT MAST - KIT SPOSTAMENTO LATERALE			Qte-Menge-Cant-Qty-Q.ta										5 AA 8062									
	Rep Hinw Fig Item Rif	Numéro Teil-Nr Numero Part-Nr Part-Nr	Désignation Bezeichnung Descripcion Description Descrizione	1	2	3	4	5	6	7	8	9	10	11	12	13	14	15	16	17	18	19	20
1	51300842	Déplacement latéral Cylindre Side Shift Cyl 3B Cilindro di spostamento laterale	- Seitenverschiebung Zylinder - Cilindro de cambio lateral	1	1	1	1					1	1	1	1								
2	51300864	Pin de déplacement latéral Side Shift Pin Pin Spostamento laterale	- Seitenverschiebung Pin - Perno de cambio lateral	2	2	2	2					2	2	2	2								
3	51300869	Déplacement latéral Weldment Side Shift Plate Wldmnt Gruppo saldato di spostamento laterale	- Seitenverschiebung Weldment - Ensemble de cambio lateral	1	1	1	1					1	1	1	1								
4	51300881	Arbre de déplacement latéral Side Shift Shaft Albero di spostamento laterale	- Seitenverschiebung Shaft - Eje de cambio lateral	1	1	1	1					1	1	1	1								
5	51300883	Déplacement latéral retenue Pin Side Shift Retain Pin Spostamento laterale Fermo Pin	- Seitenverschiebu Haltestift - Perno de Ret. de cambio lat	2	2	2	2					2	2	2	2								
6	51300888	Goupille Roll Pin .38 x 2.25L Znc Rotolo Pin	- Walzenzapfen - Perno	2	2	2	2					2	2	2	2								
7	29475	Vis Bolt, M12-1.75 X 45 Plated Hex Vite	- Schraube - Tornillo	2	2	2	2					2	2	2	2								
8	42231	Rondelle Washer.w 12 Zn12a/Fe/Cr3/I-bdm-008 Rondella	- Dichtung - Arandela	4	4	4	4					4	4	4	4								
9	42232	Rondelle Washer M10 Zn12a/Fe/Cr3/I-bdm-008 Rondella	- Dichtung - Arandela	2	2	2	2					2	2	2	2								
10	63547	Vis Bolt, M10-1.5 X 20 Plated Hex Vite	- Schraube - Tornillo	2	2	2	2					2	2	2	2								
11	63727	Vis Bolt, M10-1.5 X 20 Plated Hex Vite	- Schraube - Tornillo	2	2	2	2					2	2	2	2								

+

Catalogue : 647483

2	MÂT - DÉPLACEMENT LATÉRAL KIT MAST - SEITENVERSCHIEBUNG KIT MASTIL - KIT DE DESPLAZADOR LATERAL MAST- SIDE SHIFT KIT MAST - KIT SPOSTAMENTO LATERALE			Qte-Menge-Cant-Qty-Q.ta										5 AA 8062									
	Rep Hinw Fig Item Rif	Numéro Teil-Nr Numero Part-Nr Part-Nr	Désignation Bezeichnung Descripcion Description Descrizione	1	2	3	4	5	6	7	8	9	10	11	12	13	14	15	16	17	18	19	20
12	803734	Tige de fin Rod End Assy Canna finale - Stange Ende - Barra de acoplamiento	1	1	1	1						1	1	1									

M

6 AA 8012

CHASSIS - CONTREPOIDS
GESTELL - GEGENGEWICHT
BASTIDOR - CONTRAPESO
FRAME - COUNTERWEIGHT
TELAIO - CONTRAPPESO

M 26-2/4 ST3B M 26-2/4H ST3B
M 30-2/4 ST3B M 30-2/4H ST3B

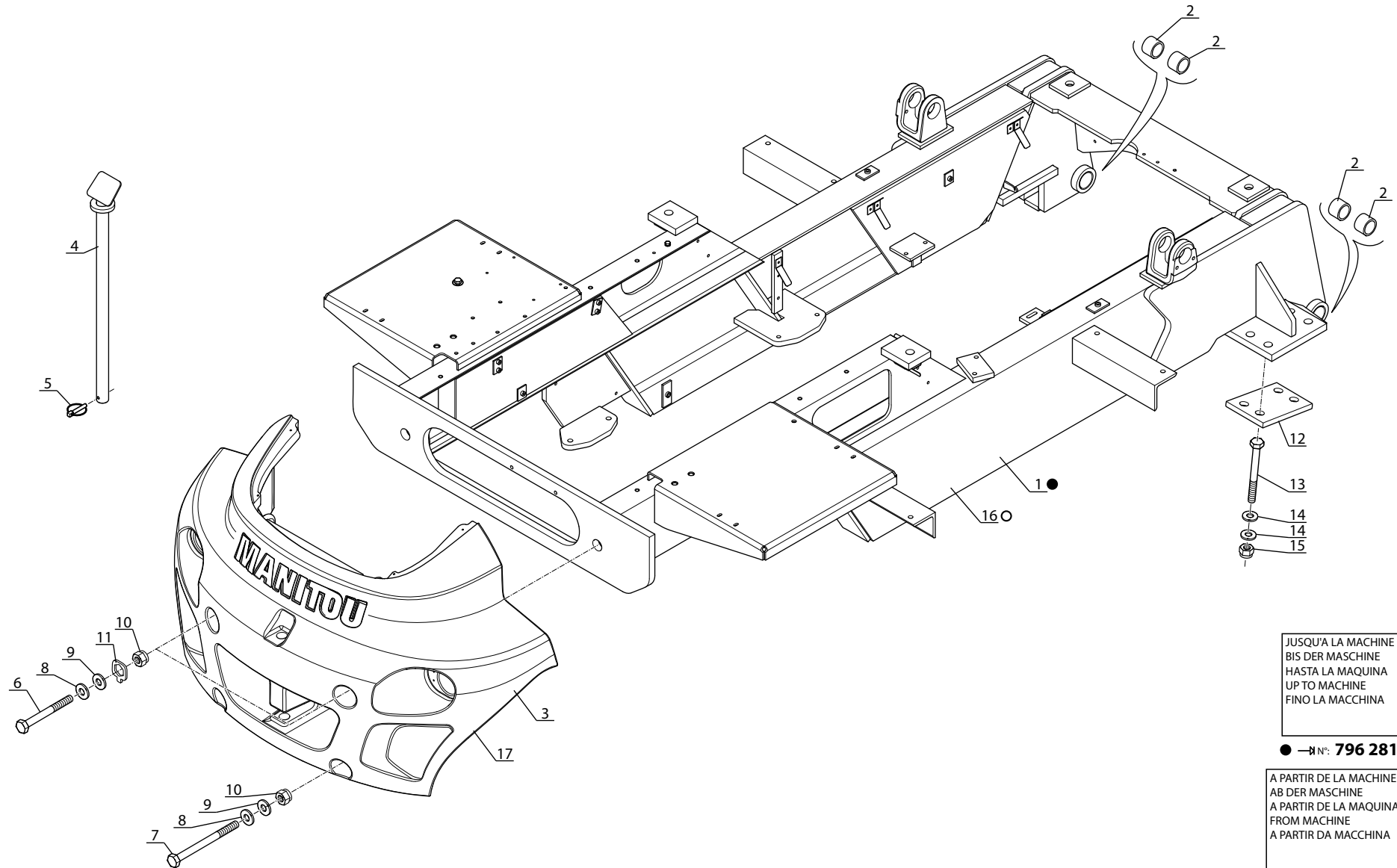

JUSQU'À LA MACHINE
BIS DER MASCHINE
HASTA LA MAQUINA
UP TO MACHINE
FINO LA MACCHINA

● — N°: 796 281

A PARTIR DE LA MACHINE
AB DER MASCHINE
A PARTIR DE LA MAQUINA
FROM MACHINE
A PARTIR DA MACCHINA

○ — N°: 796 282

P.A.O. illus

Catalogue : 647483

1				Qte-Menge-Cant-Qty-Q.ta										6 AA 8012										
CHASSIS - CONTREPOIDS GESTELL - GEGENGEWICHT BASTIDOR - CONTRAPESO FRAME - COUNTERWEIGHT TELAIO - CONTRAPPESO				1- M26- 2 ST3B 2- M26- 4 ST3B 3- M30- 2 ST3B 4- M30- 4 ST3B 5- M40- 2 ST3B 6- M40- 4 ST3B 7- M50- 2 ST3B 8- M50- 4 ST3B 9- M26- 2H ST3B 10-M26- 4H ST3B										11 - M30- 2H ST3B 12 - M30- 4H ST3B 13 - M40- 2H ST3B 14 - M40- 4H ST3B 15 - M50- 2H ST3B 16 - M50- 4H ST3B 17 - 18 - 19 - 20 -										
Rep Hinw Fig Item Rif	Número Teil-Nr Numero Part-Nr Part-Nr	Désignation Bezeichnung Descripcion Description Descrizione		1	2	3	4	5	6	7	8	9	10	11	12	13	14	15	16	17	18	19	20	
1	305079	Châssis M30 Bastidor Telaio	- Gestell - Frame	1	1	1	1						1	1	1	1								
2	77408	Bague Anillo Anello	- Büchse - Bushing	4	4	4	4					4	4	4	4									
3	301778	Contrepoids M30 Contrapeso Contrappeso	- Gegengewicht - Counterweight				1	1							1	1								
4	305685	Broche de remorquage Brocha de remolque Broccia di traino	- Schleppspindel - Towing spindle	1	1	1	1						1	1	1	1								
5	32963	Goupille Pasador Spina	- Stift - Pin	1	1	1	1						1	1	1	1								
6	75992	Vis H,M24-190-8.8-ZN12/C Tornillo Vite	- Schraube - Screw	2	2	2	2						2	2	2	2								
7	168379	Vis H,M24-250-8.8-ZN12/C Tornillo Vite	- Schraube - Screw	2	2	2	2						2	2	2	2								
8	63936	Rondelle SP 25,5x 50x8ZN Arandela Rondella	- Unterlegscheibe - Washer	4	4	4	4						4	4	4	4								
9	61685	Rondelle M 24 ZN Arandela Rondella	- Unterlegscheibe - Washer	4	4	4	4						4	4	4	4								
10	184642	Ecrou H,FR M24 zingué Tuerca Dado	- Mutter - Nut	4	4	4	4						4	4	4	4								
11	302491	Cage d'écrou M24 Caja de tuerca Gabbia dado	- Mutter gehäuse - Nut cage	2	2	2	2						2	2	2	2								

M

+

Catalogue : 647483

2	CHASSIS - CONTREPOIDS GESTELL - GEGENGEWICHT BASTIDOR - CONTRAPESO FRAME - COUNTERWEIGHT TELAIO - CONTRAPPESO			Qte-Menge-Cant-Qty-Q.ta										6 AA 8012									
	Rep Hinw Fig Item Rif	Numéro Teil-Nr Numero Part-Nr Part-Nr	Désignation Bezeichnung Descripcion Description Descrizione	1	2	3	4	5	6	7	8	9	10	11	12	13	14	15	16	17	18	19	20
12	244373	Plaque de fixation Placa de fijación Piastra di fissaggio	- Befestigung Platte - Fastening plate	2	2	2	2					2	2	2	2								
13	75596	Vis H,M20-230-8.8-ZN8/C Tornillo Vite	- Schraube - Screw	8	8	8	8					8	8	8	8								
14	196460	Rondelle Z20 ZN 160HV Arandela Rondella	- Unterlegscheibe - Washer	16	16	16	16					16	16	16	16								
15	185054	Ecrou H,FR M20 zingué Tuerca Dado	- Mutter - Nut	8	8	8	8					8	8	8	8								
16	310567	Châssis M30 Bastidor Telaio	- Gestell - Frame	1	1	1	1					1	1	1	1								
17	51300841	Contrepoids M26 Contrapeso Contrappeso	- Gegengewicht - Counterweight	1	1							1	1										

M

6 AA 8013

CHASSIS - CONTREPOIDS
GESTELL - GEGENGEWICHT
BASTIDOR - CONTRAPESO
FRAME - COUNTERWEIGHT
TELAIO - CONTRAPPESO

M 40-2/4 ST3B M 40-2/4H ST3B
M 50-2/4 ST3B M 50-2/4H ST3B

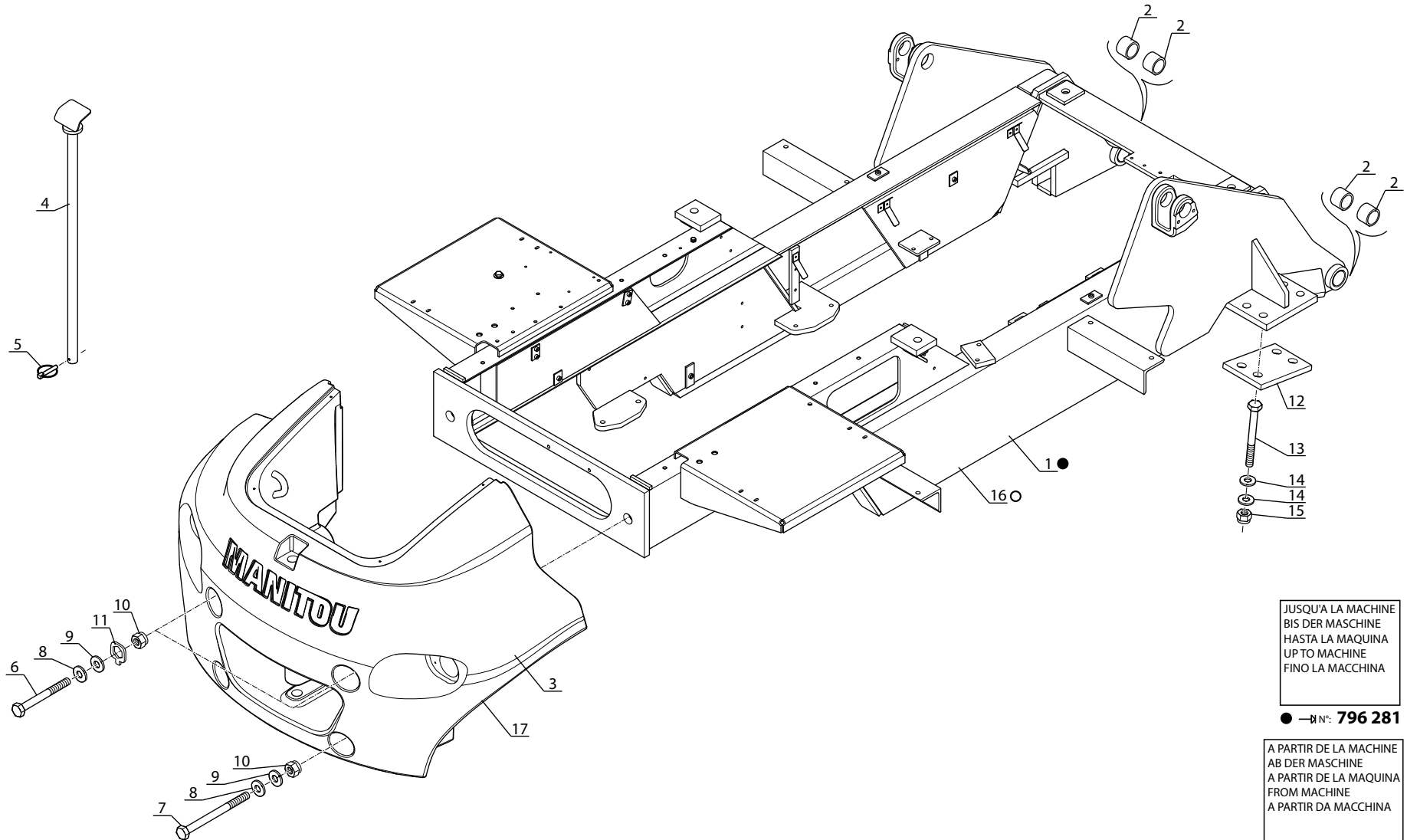

JUSQU'A LA MACHINE
BIS DER MASCHINE
HASTA LA MAQUINA
UP TO MACHINE
FINO LA MACCHINA

● —N°: 796 281

A PARTIR DE LA MACHINE
AB DER MASCHINE
A PARTIR DE LA MAQUINA
FROM MACHINE
A PARTIR DA MACCHINA

○ —N°: 796 282

Catalogue : 647483

Rep Hinw Fig Item Rif	Numéro Teil-Nr Numero Part-Nr Part-Nr	Désignation Bezeichnung Descripcion Description Descrizione	Qte-Menge-Cant-Qty-Q.ta										6 AA 8013									
			1	2	3	4	5	6	7	8	9	10	11	12	13	14	15	16	17	18	19	20
			1	300398	CHASSIS - CONTREPOIDS GESTELL - GEGENGEWICHT BASTIDOR - CONTRAPESO FRAME - COUNTERWEIGHT TELAIO - CONTRAPPESO Châssis M50 Bastidor Telaio					1	1	1	1					1	1	1	1	
2	77408	Bague Anillo Anello					4	4	4	4				4	4	4	4					
3	299995	Contrepoids M50 Contrapeso Contrappeso							1	1						1	1					
4	301895	Broche de remorquage Brocha de remolque Broccia di traino					1	1	1	1				1	1	1	1					
5	32963	Goupille Pasador Spina					1	1	1	1				1	1	1	1					
6	75992	Vis H,M24-190-8.8-ZN12/C Tornillo Vite					2	2	2	2				2	2	2	2					
7	168379	Vis H,M24-250-8.8-ZN12/C Tornillo Vite					2	2	2	2				2	2	2	2					
8	63936	Rondelle SP 25,5x50x8ZN Arandela Rondella					4	4	4	4				4	4	4	4					
9	61685	Rondelle M 24 ZN Arandela Rondella					4	4	4	4				4	4	4	4					
10	184642	Ecrou H,FR M24 zingué Tuerca Dado					4	4	4	4				4	4	4	4					
11	302491	Cage d'écrou M24 Caja de tuerca Gabbia dado					2	2	2	2				2	2	2	2					

+

Catalogue : 647483

Rep Hinw Fig Item Rif	Numéro Teil-Nr Numero Part-Nr Part-Nr	Désignation Bezeichnung Descripción Description Descrizione	Qte-Menge-Cant-Qty-Q.ta										6 AA 8013									
			1	2	3	4	5	6	7	8	9	10	11	12	13	14	15	16	17	18	19	20
2		CHASSIS - CONTREPOIDS GESTELL - GEGENGEWICHT BASTIDOR - CONTRAPESO FRAME - COUNTERWEIGHT TELAIO - CONTRAPPESO	1- M26- 2 ST3B 2- M26- 4 ST3B 3- M30- 2 ST3B 4- M30- 4 ST3B 5- M40- 2 ST3B 6- M40- 4 ST3B 7- M50- 2 ST3B 8- M50- 4 ST3B 9- M26- 2H ST3B 10-M26- 4H ST3B										11 - M30- 2H ST3B 12 - M30- 4H ST3B 13 - M40- 2H ST3B 14 - M40- 4H ST3B 15 - M50- 2H ST3B 16 - M50- 4H ST3B 17 - 18 - 19 - 20 -									
12	244373	Plaque de fixation Placa de fijación Piastra di fissaggio - Befestigung Platte - Fastening plate					2	2	2	2												
13	75596	Vis H,M20-230-8.8-ZN8/C Tornillo Vite - Schraube - Screw					8	8	8	8					8	8	8	8				
14	196460	Rondelle Z20 ZN 160HV Arandela Rondella - Unterlegscheibe - Washer					16	16	16	16					16	16	16	16				
15	185054	Ecrou H,FR M20 zingué Tuerca Dado - Mutter - Nut					8	8	8	8					8	8	8	8				
16	310556	Châssis M50 Bastidor Telaio - Gestell - Frame					1	1	1	1					1	1	1	1				
17	51300786	Contrepoids M40 Contrapeso Contrappeso - Gegengewicht - Counterweight					1	1							1	1						

M

6 BA 8014

FREIN A MAIN
HANDBREMSE
FRENO DE MANO
HANDBRAKE
FRENO A MANO

M 26-2/4 ST3B M 26-2/4H ST3B
M 30-2/4 ST3B M 30-2/4H ST3B
M 40-2/4 ST3B M 40-2/4H ST3B
M 50-2/4 ST3B M 50-2/4H ST3B

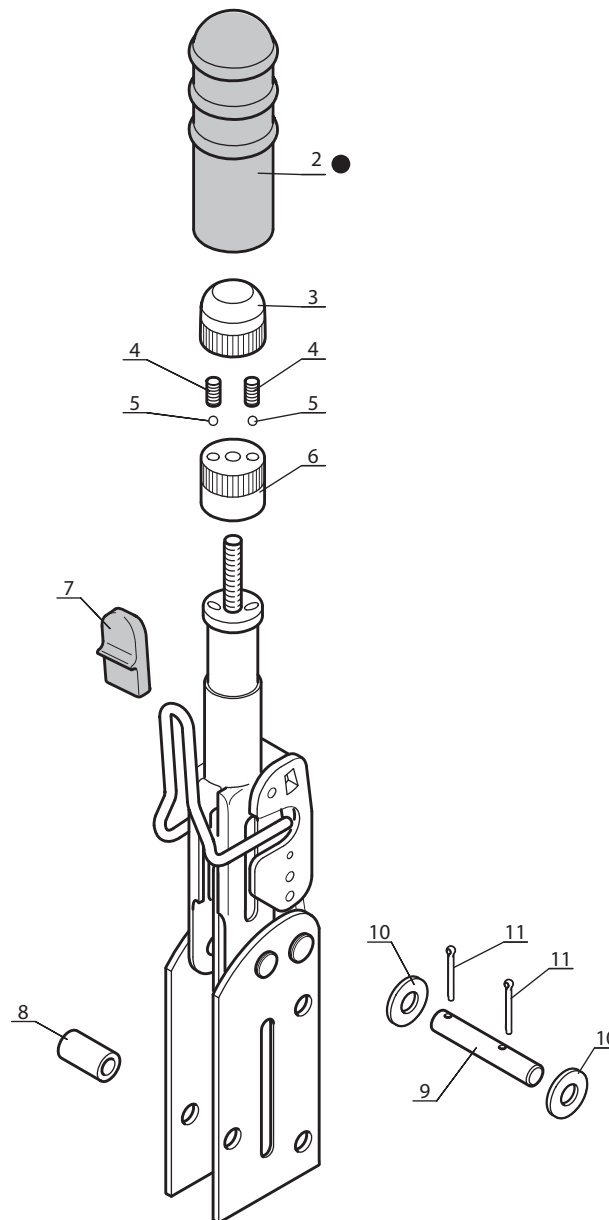
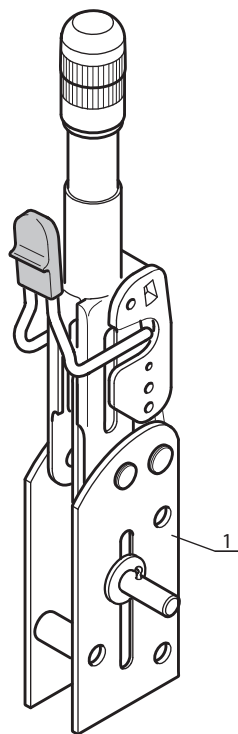

● NON LIVRE AVEC REP. 1
NICHT GELIEFERT MIT HINW. 1
NO ENTREGADOS CON FIG. 1
NOT DELIVERED WITH ITEM. 1
NO CONSEGNARE CON SEQU. 1

Catalogue : 647483

1	FREIN A MAIN HANDBREMSE FRENO DE MANO HANDBRAKE FRENO A MANO			Qte-Menge-Cant-Qty-Q.ta										6 BA 8014					M				
	Rep Hinw Fig Item Rif	Numéro Teil-Nr Numero Part-Nr Part-Nr	Désignation Bezeichnung Descripcion Description Descrizione	1	2	3	4	5	6	7	8	9	10	11	12	13	14	15		16	17	18	19
1	243798	Frein à main complet Freno de mano completo Freno a mano comp.	- Kompletter handbremse - Complete Handbrake	1	1	1	1	1	1	1	1	1	1	1	1	1	1	1	1				
2	563550	Poignée (caoutchouc) Agarrador (goma) Maniglia (gomma)	- Handgriff (gummi) - Handle (rubber)	1	1	1	1	1	1	1	1	1	1	1	1	1	1	1	1				
3	702032	Bouton semi-externe Boton Bottone semi-estern	- Knopf - Button	1	1	1	1	1	1	1	1	1	1	1	1	1	1	1	1				
4	49370	Ressort Muelle Molla	- Feder - Spring	2	2	2	2	2	2	2	2	2	2	2	2	2	2	2	2				
5	49369	Bille Bola Sfera	- Kugel - Ball	2	2	2	2	2	2	2	2	2	2	2	2	2	2	2	2				
6	702033	Bouton semi-externe Boton Bottone semi-esterni	- Knopf - Button	1	1	1	1	1	1	1	1	1	1	1	1	1	1	1	1				
7	563553	Capuchon Capuchón Cappuccioi	- Kappe - Cap	1	1	1	1	1	1	1	1	1	1	1	1	1	1	1	1				
8	49330	Entretoise Separador Distanziale	- Querstrebe - Spacer	3	3	3	3	3	3	3	3	3	3	3	3	3	3	3	3				
9	563447	Axe Eje Perno	- Bolzen - Pin	1	1	1	1	1	1	1	1	1	1	1	1	1	1	1	1				
10	563448	Rondelle Arandela Rondella	- Unterlegscheibe - Washer	2	2	2	2	2	2	2	2	2	2	2	2	2	2	2	2				
11	563449	Goupille Pasador Spina	- Stift - Pin	2	2	2	2	2	2	2	2	2	2	2	2	2	2	2	2				

6 BA 8015

CIRCUIT FREINAGE
BREMSEKREIS
CIRCUITO FRENADO
BRAKE CIRCUIT
CIRCUITO FRENANTE

M 26-2/4 ST3B M 26-2/4H ST3B
M 30-2/4 ST3B M 30-2/4H ST3B
M 40-2/4 ST3B M 40-2/4H ST3B
M 50-2/4 ST3B M 50-2/4H ST3B

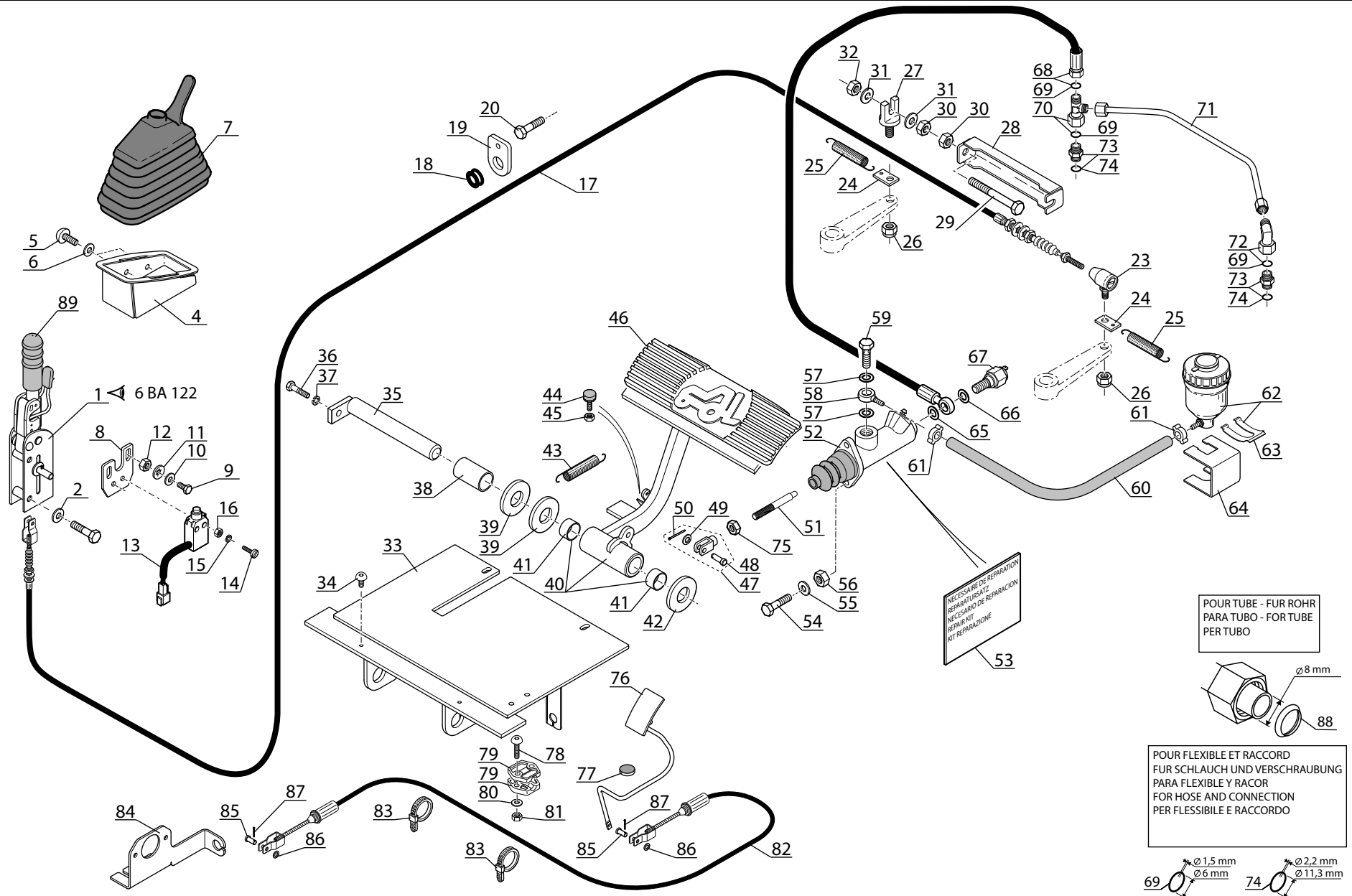

Catalogue : 647483

1	CIRCUIT FREINAGE BREMSEKREIS CIRCUITO FRENADO BRAKE CIRCUIT CIRCUITO FRENANTE			Qte-Menge-Cant-Qty-Q.ta										6 BA 8015									
	Rep Hinw Fig Item Rif	Numéro Teil-Nr Numero Part-Nr Part-Nr	Désignation Bezeichnung Descripcion Description Descrizione	1- M26- 2 ST3B 2- M26- 4 ST3B 3- M30- 2 ST3B 4- M30- 4 ST3B 5- M40- 2 ST3B 6- M40- 4 ST3B 7- M50- 2 ST3B 8- M50- 4 ST3B 9- M26- 2H ST3B 10-M26- 4H ST3B										11 - M30- 2H ST3B 12 - M30- 4H ST3B 13 - M40- 2H ST3B 14 - M40- 4H ST3B 15 - M50- 2H ST3B 16 - M50- 4H ST3B 17 - 18 - 19 - 20 -									
				1	2	3	4	5	6	7	8	9	10	11	12	13	14	15	16	17	18	19	20
1	243798	Frein à main comp. Freno de mano comp. Freno a mano completo	- Kompletter handbremse - Complete Handbrake	1	1	1	1	1	1	1	1	1	1	1	1	1	1						
2	29437	Rondelle M 10 ZN Arandela Rondella	- Unterlegscheibe - Washer	2	2	2	2	2	2	2	2	2	2	2	2	2	2						
4	261909	Support soufflet Soporte fuelle Supporto soffietto	- Blasebalg Träger - Bellows bracket	1	1	1	1	1	1	1	1	1	1	1	1	1							
5	196951	Vis CBHc,M 6- 12-10.9-ZN5/NOIR Tornillo Vite	- Schraube - Screw	1	1	1	1	1	1	1	1	1	1	1	1	1	1						
6	189857	Rondelle M 6 ZN PASS.NOIRE Arandela Rondella	- Unterlegscheibe - Washer	1	1	1	1	1	1	1	1	1	1	1	1	1	1						
7	243197	Soufflet Fuelle Soffietto	-Blasebalg - Bellows	1	1	1	1	1	1	1	1	1	1	1	1	1	1						
8	193643	Support contacteur Soporte contactor Supporto contattore	- Schalter träger - Switch bracket	1	1	1	1	1	1	1	1	1	1	1	1	1	1						
9	25713	Vis H,M 6- 16-8.8-ZN5/C Tornillo Vite	- Schraube - Screw	1	1	1	1	1	1	1	1	1	1	1	1	1	1						
10	29469	Rondelle M 6 ZN Arandela Rondella	- Unterlegscheibe - Washer	1	1	1	1	1	1	1	1	1	1	1	1	1	1						
11	174132	Rondelle JZC 6 CAD.BICH Arandela Rondella	- Unterlegscheibe - Washer	1	1	1	1	1	1	1	1	1	1	1	1	1	1						
12	25714	Ecrou H ,M 6 ZN Tuerca Dado	- Mutter - Nut	1	1	1	1	1	1	1	1	1	1	1	1	1	1						

M

+

Catalogue : 647483

2	CIRCUIT FREINAGE BREMSEKREIS CIRCUITO FRENADO BRAKE CIRCUIT CIRCUITO FRENANTE		Qte-Menge-Cant-Qty-Q.ta										6 BA 8015										
	Rep Hinw Fig Item Rif	Número Teil-Nr Numero Part-Nr Part-Nr	Désignation Bezeichnung Descripcion Description Descrizione	1	2	3	4	5	6	7	8	9	10	11	12	13	14	15	16	17	18	19	20
13	279810	Contacteur frein à main Contactor fr.de mano Contattore fr. a mano	- Handbremseshalter - Handbrake switch	1	1	1	1	1	1	1	1	1	1	1	1	1	1	1	1				
14	31120	Vis CS,M 4-20 zinguée Tornillo Vite	- Schraube - Screw	2	2	2	2	2	2	2	2	2	2	2	2	2	2	2	2				
15	28987	Rondelle W 4 ZN Arandela Rondella	- Unterlegscheibe - Washer	2	2	2	2	2	2	2	2	2	2	2	2	2	2	2	2				
16	25758	Ecrou H ,M 4 ZN Tuerca Dado	- Mutter - Nut	2	2	2	2	2	2	2	2	2	2	2	2	2	2	2	2				
17	237802	Câble de frein à main Cable de fr. a mano Cavo freno a mano	- Handbremszug - Handbrake cable	1	1	1	1	1	1	1	1	1	1	1	1	1	1	1	1				
18	235171	Passe-fil Arandela de gaucho Passo-filo	- Gummischeibe - Cable grommet	1	1	1	1	1	1	1	1	1	1	1	1	1	1	1	1				
19	219180	Guide câble Guía cable Guida cavo	- Führungskabel - Guide cable	1	1	1	1	1	1	1	1	1	1	1	1	1	1	1	1				
20	63727	Vis H,M10-20-8.8-ZN8/C Tornillo Vite	- Schraube - Screw	1	1	1	1	1	1	1	1	1	1	1	1	1	1	1	1				
23	230605	Rotule Rótula Rotula	- Kugelgelenk - Knee-joint	1	1	1	1	1	1	1	1	1	1	1	1	1	1	1	1				
24	164965	Plaque de fixation Placa de fijación Piastra di fissaggio	- Befestigung Platte - Fastening plate	2	2	2	2	2	2	2	2	2	2	2	2	2	2	2	2				
25	220645	Ressort Muelle Molla	- Feder - Spring	2	2	2	2	2	2	2	2	2	2	2	2	2	2	2	2				

M

+

Catalogue : 647483

3	CIRCUIT FREINAGE BREMSEKREIS CIRCUITO FRENADO BRAKE CIRCUIT CIRCUITO FRENANTE			Qte-Menge-Cant-Qty-Q.ta										6 BA 8015									
	Rep Hinw Fig Item Rif	Numéro Teil-Nr Numero Part-Nr Part-Nr	Désignation Bezeichnung Descripcion Description Descrizione	1- M26- 2 ST3B 2- M26- 4 ST3B 3- M30- 2 ST3B 4- M30- 4 ST3B 5- M40- 2 ST3B 6- M40- 4 ST3B 7- M50- 2 ST3B 8- M50- 4 ST3B 9- M26- 2H ST3B 10-M26- 4H ST3B										11 - M30- 2H ST3B 12 - M30- 4H ST3B 13 - M40- 2H ST3B 14 - M40- 4H ST3B 15 - M50- 2H ST3B 16 - M50- 4H ST3B 17 - 18 - 19 - 20 -									
				1	2	3	4	5	6	7	8	9	10	11	12	13	14	15	16	17	18	19	20
26	55714	Ecrou H,FR M10 zingué Tuerca Dado	- Mutter - Nut	2	2	2	2	2	2	2	2	2	2	2	2	2							
27	514278	Arrêt de gaine Parada de funda Arresto di guaina	- Pofte - Fastener	1	1	1	1	1	1	1	1	1	1	1	1	1							
28	233353	Boîtier Cârter Scatola	- Kasten - Box	1	1	1	1	1	1	1	1	1	1	1	1	1							
29	223481	Vis H,M12-100-8.8-ZN8/C Tornillo Vite	- Schraube - Screw	1	1	1	1	1	1	1	1	1	1	1	1	1							
30	58548	Ecrou H ,M12 C 8 ZN..C Tuerca Dado	- Mutter - Nut	2	2	2	2	2	2	2	2	2	2	2	2	2							
31	61676	Rondelle M 12 ZN Arandela Rondella	- Unterlegscheibe - Washer	2	2	2	2	2	2	2	2	2	2	2	2	2							
32	44672	Ecrou H,FR M12C8 ZN.C Tuerca Dado	- Mutter - Nut	1	1	1	1	1	1	1	1	1	1	1	1	1							
33	307209	Support pédalerie Soporte pedales Supporto pedali	- Pedalenträger - Pedals bracket	1	1	1	1	1	1	1	1	1	1	1	1	1							
34	189172	Vis CBHc,M 6-16-10.9-ZN5/NOIR Tornillo Vite	- Schraube - Screw	4	4	4	4	4	4	4	4	4	4	4	4	4							
35	79412	Axe d'articulation Eje de articulación Perno di articolazione	- Gelenkachse - Articulating pin	1	1	1	1	1	1	1	1	1	1	1	1	1							
36	54951	Vis H,M 8-16-8.8-ZN8/C Tornillo Vite	- Schraube - Screw	1	1	1	1	1	1	1	1	1	1	1	1	1							

M

+

Catalogue : 647483

4	CIRCUIT FREINAGE BREMSEKREIS CIRCUITO FRENADO BRAKE CIRCUIT CIRCUITO FRENANTE			Qte-Menge-Cant-Qty-Q.ta										6 BA 8015									
	Rep Hinw Fig Item Rif	Numéro Teil-Nr Numero Part-Nr Part-Nr	Désignation Bezeichnung Descripcion Description Descrizione	11 - M30- 2H ST3B 12 - M30- 4H ST3B 13 - M40- 2H ST3B 14 - M40- 4H ST3B 15 - M50- 2H ST3B 16 - M50- 4H ST3B 17 - 18 - 19 - 20 -																			
				1	2	3	4	5	6	7	8	9	10	11	12	13	14	15	16	17	18	19	20
37	42325	Rondelle W 8 ZN Arandela Rondella	- Unterlegscheibe - Washer	1	1	1	1	1	1	1	1	1	1	1	1	1	1						
38	79414	Tube PVC Tubo Tubo	- Rohr - Tube	1	1	1	1	1	1	1	1	1	1	1	1	1	1						
39	205065	Rondelle SP 28,5x50x1 Arandela Rondella	- Unterlegscheibe - Washer	2	2	2	2	2	2	2	2	2	2	2	2	2	2						
40	268857	Pédale de frein Pedal de freno Pedale pompa freno	- Bremsepedal - Brake pedal	1	1	1	1	1	1	1	1	1	1	1	1	1	1						
41	172569	Bague Anillo Anello	- Büchse - Bushing	2	2	2	2	2	2	2	2	2	2	2	2	2	2						
42	205065	Rondelle SP 28,5x50x1 Arandela Rondella	- Unterlegscheibe - Washer	x	x	x	x	x	x	x	x	x	x	x	x	x	x						
42	220370	Rondelle SP 28,5x50x2 Arandela Rondella	- Unterlegscheibe - Washer	x	x	x	x	x	x	x	x	x	x	x	x	x	x						
43	80308	Ressort Muelle Molla	- Feder - Spring	1	1	1	1	1	1	1	1	1	1	1	1	1	1						
44	53501	Butée Tope Battuta	- Anschlag - Stop	1	1	1	1	1	1	1	1	1	1	1	1	1	1						
45	25714	Ecrou H ,M 6 ZN Tuerca Dado	- Mutter - Nut	1	1	1	1	1	1	1	1	1	1	1	1	1	1						
46	240820	Couvre pédale Cubre pedal Gomma pedale	- Deck pedal - Cover pedal	1	1	1	1	1	1	1	1	1	1	1	1	1	1						

M

+

Catalogue : 647483

Rep Hinw Fig Item Rif	Numéro Teil-Nr Numero Part-Nr Part-Nr	Désignation Bezeichnung Descripcion Description Descrizione	Qte-Menge-Cant-Qty-Q.ta										6 BA 8015									
			1	2	3	4	5	6	7	8	9	10	11	12	13	14	15	16	17	18	19	20
			47	5549	Chape complète Abrazadera completa Forchetta completa	- Kompletter gabelgelenk - Complete fork joint	1	1	1	1	1	1	1	1	1	1	1	1	1	1	1	1
48	4350	Axe Eje Perno	- Bolzen - Pin	1	1	1	1	1	1	1	1	1	1	1	1	1	1	1	1	1	1	
49	29437	Rondelle M 10 ZN Arandela Rondella	- Unterlegscheibe - Washer	1	1	1	1	1	1	1	1	1	1	1	1	1	1	1	1	1	1	
50	61344	Goupille V 3,2x25 zinguee Pasador Spina	- Stift - Pin	1	1	1	1	1	1	1	1	1	1	1	1	1	1	1	1	1	1	
51	219834	Poussoir maître cyl. Empujador cil. de fr Spintore cilindro maestro	- Hauptzylinderstoss - Master cyl. pusher	1	1	1	1	1	1	1	1	1	1	1	1	1	1	1	1	1	1	
52	271498	Maître cyl. complet Cil. de freno comp. Cilindro maestro comp.	- Kompletter hauptzyl - Complete master cyl.	1	1	1	1	1	1	1	1	1	1	1	1	1	1	1	1	1	1	
53	748418	Nécessaire de rép. Necesario de reparación Kit riparazione	- Reparatursatz - Repair kit	1	1	1	1	1	1	1	1	1	1	1	1	1	1	1	1	1	1	
54	57446	Vis H,M 8-25-8.8-ZN8/C Tornillo Vite	- Schraube - Screw	2	2	2	2	2	2	2	2	2	2	2	2	2	2	2	2	2	2	
55	61674	Rondelle L8 ZN12C/FE Arandela Rondella	- Unterlegscheibe - Washer	2	2	2	2	2	2	2	2	2	2	2	2	2	2	2	2	2	2	
56	54242	Ecrou H ,M 8 ZN Tuerca Dado	- Mutter - Nut	2	2	2	2	2	2	2	2	2	2	2	2	2	2	2	2	2	2	
57	80305	Joint cuivre Junta cobre Guarnizióne rame	- Kupferdichtung - Copper seal	2	2	2	2	2	2	2	2	2	2	2	2	2	2	2	2	2	2	

M

+

Catalogue : 647483

6	CIRCUIT FREINAGE BREMSEKREIS CIRCUITO FRENADO BRAKE CIRCUIT CIRCUITO FRENANTE			Qte-Menge-Cant-Qty-Q.ta										6 BA 8015									
	Rep Hinw Fig Item Rif	Numéro Teil-Nr Numero Part-Nr Part-Nr	Désignation Bezeichnung Descripcion Description Descrizione	1- M26- 2 ST3B 11 - M30- 2H ST3B 2- M26- 4 ST3B 12 - M30- 4H ST3B 3- M30- 2 ST3B 13 - M40- 2H ST3B 4- M30- 4 ST3B 14 - M40- 4H ST3B 5- M40- 2 ST3B 15 - M50- 2H ST3B 6- M40- 4 ST3B 16 - M50- 4H ST3B 7- M50- 2 ST3B 17 - 8- M50- 4 ST3B 18 - 9- M26- 2H ST3B 19 - 10-M26- 4H ST3B 20 -																			
				1	2	3	4	5	6	7	8	9	10	11	12	13	14	15	16	17	18	19	20
58	218075	Raccord banjo Racor banjo Raccordo	- Verschraubung - Banjo connection	1	1	1	1	1	1	1	1	1	1	1	1	1	1	1	1	1			
59	218074	Vis creuse Tornillo hueco Vite cava	- Hohl schraube - Hollow screw	1	1	1	1	1	1	1	1	1	1	1	1	1	1	1	1	1			
60	193953	Durit Tubo flexible Manicotto	- Schlauch - Hose	1	1	1	1	1	1	1	1	1	1	1	1	1	1	1	1	1			
61	B2236-11	Collier Ø 11.5-13 Abrazadera Fascetta	- Spannschelle - Clamp	2	2	2	2	2	2	2	2	2	2	2	2	2	2	2	2	2			
62	219559	Réser. liquide de fr Tanque liquido de fr. Serbatoio liquido freni	- Bremsflüssigkeitsbehälter - Brake fluid tank	1	1	1	1	1	1	1	1	1	1	1	1	1	1	1	1	1			
63	561723	Clip Clip Fermaglio	- Klammer - Clip	1	1	1	1	1	1	1	1	1	1	1	1	1	1	1	1	1			
64	218023	Support Soporte Supporto	- Träger - Bracket	1	1	1	1	1	1	1	1	1	1	1	1	1	1	1	1	1			
65	233837	Joint cuivre Junta cobre Guarnizióne rame	- Kupferdichtung - Copper seal	1	1	1	1	1	1	1	1	1	1	1	1	1	1	1	1	1			
66	81044	Joint cuivre Junta cobre Guarnizióne rame	- Kupferdichtung - Copper seal	1	1	1	1	1	1	1	1	1	1	1	1	1	1	1	1	1			
67	79126	Contacteur stop Contactor pare Contattore di stop	- Bremslichtschalter - Stop switch	1	1	1	1	1	1	1	1	1	1	1	1	1	1	1	1	1			
68	217947	Flexible Flexible Flessibile	- Schlauch - Hose	1	1	1	1	1	1	1	1	1	1	1	1	1	1	1	1	1			

M

+

Catalogue : 647483

7	CIRCUIT FREINAGE BREMSEKREIS CIRCUITO FRENADO BRAKE CIRCUIT CIRCUITO FRENANTE			Qte-Menge-Cant-Qty-Q.ta										6 BA 8015									
	Rep Hinw Fig Item Rif	Numéro Teil-Nr Numero Part-Nr Part-Nr	Désignation Bezeichnung Descripcion Description Descrizione	1- M26- 2 ST3B 2- M26- 4 ST3B 3- M30- 2 ST3B 4- M30- 4 ST3B 5- M40- 2 ST3B 6- M40- 4 ST3B 7- M50- 2 ST3B 8- M50- 4 ST3B 9- M26- 2H ST3B 10-M26- 4H ST3B										11 - M30- 2H ST3B 12 - M30- 4H ST3B 13 - M40- 2H ST3B 14 - M40- 4H ST3B 15 - M50- 2H ST3B 16 - M50- 4H ST3B 17 - 18 - 19 - 20 -									
				1	2	3	4	5	6	7	8	9	10	11	12	13	14	15	16	17	18	19	20
69	190013	Joint torique Junta tórica Anello OR	- "0" ring - "0" ring	X	X	X	X	X	X	X	X	X	X	X	X	X							
70	190442	Raccord Té Adapteur Racor Raccordo	- Verschraubung - Connection	1	1	1	1	1	1	1	1	1	1	1	1	1							
71	237806	Tube Tubo Tubo	- Rohr - Tube	1	1	1	1	1	1	1	1	1	1	1	1	1							
72	497922	Racc. Coudé 90° Adap. Racor Raccordo	- Verschraubung - Connection	1	1	1	1	1	1	1	1	1	1	1	1	1							
73	175498	Raccord Union Racor Raccordo	- Verschraubung - Connection	2	2	2	2	2	2	2	2	2	2	2	2	2							
74	177588	Joint torique Junta tórica Anello OR	- "0" ring - "0" ring	X	X	X	X	X	X	X	X	X	X	X	X	X							
75	56354	Ecrou H ,M10 zingué Tuerca Dado	- Mutter - Nut	1	1	1	1	1	1	1	1	1	1	1	1	1							
76	218013	Pédale d'accélérateur Pedal de acelerador Pedale acceleratore	- Gaspedal - Accelerator pedal	1	1	1	1	1	1	1	1	1	1	1	1	1							
77	184130	Butée Tope Battuta	- Anschlag - Stop	1	1	1	1	1	1	1	1	1	1	1	1	1							
78	190807	Vis CBHc,M 6-30-10.9-ZN5/NOIR Tornillo Vite	- Schraube - Screw	2	2	2	2	2	2	2	2	2	2	2	2	2							
79	77957	Guide Guía Guida	- Führungs - Guide	2	2	2	2	2	2	2	2	2	2	2	2	2							

M

+

Catalogue : 647483

8	CIRCUIT FREINAGE BREMSEKREIS CIRCUITO FRENADO BRAKE CIRCUIT CIRCUITO FRENANTE			Qte-Menge-Cant-Qty-Q.ta										6 BA 8015									
	Rep Hinw Fig Item Rif	Numéro Teil-Nr Numero Part-Nr Part-Nr	Désignation Bezeichnung Descripcion Description Descrizione	1- M26- 2 ST3B 2- M26- 4 ST3B 3- M30- 2 ST3B 4- M30- 4 ST3B 5- M40- 2 ST3B 6- M40- 4 ST3B 7- M50- 2 ST3B 8- M50- 4 ST3B 9- M26- 2H ST3B 10-M26- 4H ST3B										11 - M30- 2H ST3B 12 - M30- 4H ST3B 13 - M40- 2H ST3B 14 - M40- 4H ST3B 15 - M50- 2H ST3B 16 - M50- 4H ST3B 17 - 18 - 19 - 20 -									
				1	2	3	4	5	6	7	8	9	10	11	12	13	14	15	16	17	18	19	20
80	29469	Rondelle M 6 ZN Arandela Rondella	- Unterlegscheibe - Washer	2	2	2	2	2	2	2	2	2	2	2	2	2	2	2	2	2			
81	25714	Ecrou H ,M 6 ZN Tuerca Dado	- Mutter - Nut	2	2	2	2	2	2	2	2	2	2	2	2	2	2	2	2	2			
82	301079	Câble d'accélérateur(Lg 1880) Cable de acelerador Cavo acceleratore	- Gaskabel - Accelerator cable	1	1	1	1	1	1	1	1	1	1	1	1	1	1	1	1	1			
83	459652	Collier Abrazadera Fascetta	- Spannschelle - Clamp	2	2	2	2	2	2	2	2	2	2	2	2	2	2	2	2	2			
84	301080	Support potentiomètre Sop. potenciómetro Supporto potenziometro	- Potentiometer träger - Potentiometer bracket	1	1	1	1	1	1	1	1	1	1	1	1	1	1	1	1	1			
85	565446	Axe Eje Perno	- Bolzen - Pin	2	2	2	2	2	2	2	2	2	2	2	2	2	2	2	2	2			
86	29469	Rondelle M 6 ZN Arandela Rondella	- Unterlegscheibe - Washer	2	2	2	2	2	2	2	2	2	2	2	2	2	2	2	2	2			
87	1082	Goupille V 2x25 ZN12C Pasador Spina	- Stift - Pin	2	2	2	2	2	2	2	2	2	2	2	2	2	2	2	2	2			
88	177275	Joint d'étanchéité Junta d estanqueidad Guarnizióne	- Dichtungsring - Seal	X	X	X	X	X	X	X	X	X	X	X	X	X	X	X	X	X			
89	563550	Poignée (caoutchouc) Agarrador (goma) Maniglia (gomma)	- Handgriff (gummi) - Handle (rubber)	1	1	1	1	1	1	1	1	1	1	1	1	1	1	1	1	1			

M

6 BB 8016

PEDALIERE - TRINGLERIE
PEDALEN - GESTANGE
PEDALES - VARILLAS
PEDALS - LINKAGE
PEDALI - COMANDI

M 26-2/4 ST3B
M 30-2/4 ST3B
M 40-2/4 ST3B
M 50-2/4 ST3B

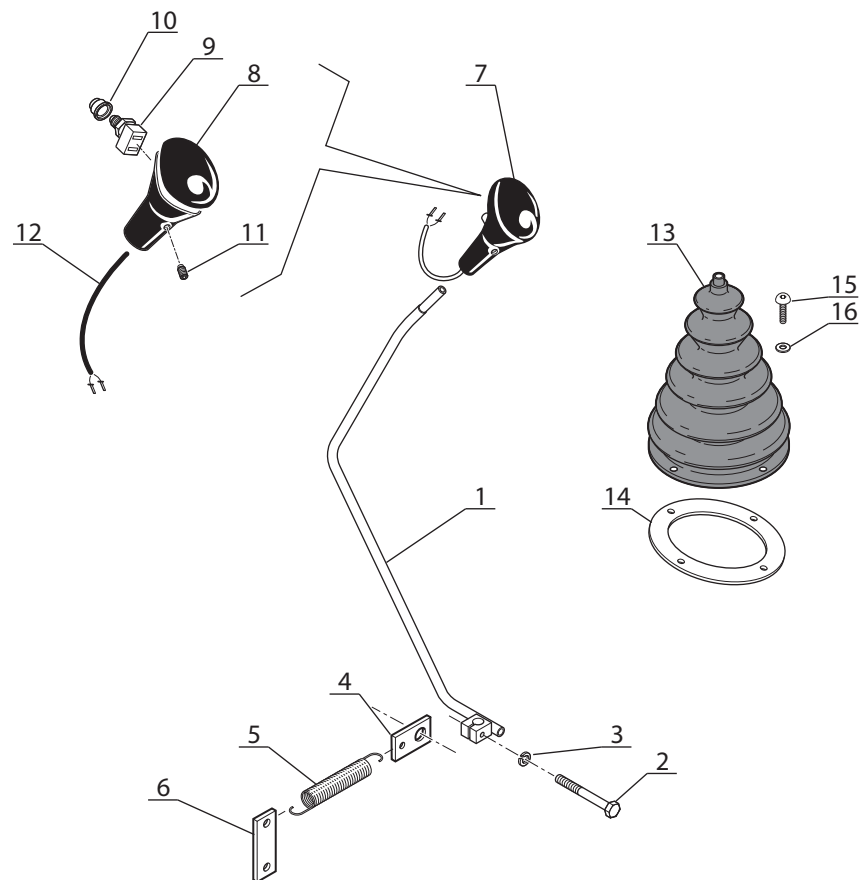

Catalogue : 647483

1	PEDALERIE - TRINGLERIE PEDALEN - GESTANGE PEDALES - VARILLAS PEDALS - LINKAGE PEDALI - COMANDI			Qte-Menge-Cant-Qty-Q.ta										6 BB 8016									
	Rep Hinw Fig Item Rif	Numéro Teil-Nr Numero Part-Nr Part-Nr	Désignation Bezeichnung Descripcion Description Descrizione	1- M26- 2 ST3B 2- M26- 4 ST3B 3- M30- 2 ST3B 4- M30- 4 ST3B 5- M40- 2 ST3B 6- M40- 4 ST3B 7- M50- 2 ST3B 8- M50- 4 ST3B 9- M26- 2H ST3B 10-M26- 4H ST3B										11 - M30- 2H ST3B 12 - M30- 4H ST3B 13 - M40- 2H ST3B 14 - M40- 4H ST3B 15 - M50- 2H ST3B 16 - M50- 4H ST3B 17 - 18 - 19 - 20 -									
				1	2	3	4	5	6	7	8	9	10	11	12	13	14	15	16	17	18	19	20
1	305462	Levier de vitesses Pal. de velocidades Leva del cambio	- Getriebehebel - Gear lever	1	1	1	1	1	1	1	1	1											
2	29475	Vis H,M12-45-8.8-ZN8/C Tornillo Vite	- Schraube - Screw	1	1	1	1	1	1	1	1	1											
3	42231	Rondelle W12 ZN Arandela Rondella	- Unterlegscheibe - Washer	1	1	1	1	1	1	1	1	1											
4	78086	Attache ressort Atadura muelle Legame molla	- Befestigung feder - Fixing spring	1	1	1	1	1	1	1	1	1											
5	80308	Ressort Muelle Molla	- Feder - Spring	1	1	1	1	1	1	1	1	1											
6	164965	Plaque de fixation Placa de fijación Piastra di fissaggio	- Befestigung Platte - Fastening plate	1	1	1	1	1	1	1	1	1											
7	211278	Boule Bola Bulbo	- Knopf - Ball	1	1	1	1	1	1	1	1	1											
8	551255	Capuchon Capuchón Cappuccio	- Kappe - Cap	1	1	1	1	1	1	1	1	1											
9	551256	Contact. coup. transm. Contact. corte tra. Contatorre taglio trasmissione	- Getriebe trenn schal. - Transmission cut-off switch	1	1	1	1	1	1	1	1	1											
10	551258	Capuchon Capuchón Cappuccio	- Kappe - Cap	1	1	1	1	1	1	1	1	1											
11	551257	Vis Hc, M 5-8 ZN Tornillo Vite	- Schraube - Screw	1	1	1	1	1	1	1	1	1											

M

+

Catalogue : 647483

Rep Hinw Fig Item Rif	Numéro Teil-Nr Numero Part-Nr Part-Nr	Désignation Bezeichnung Descripcion Description Descrizione	Qte-Menge-Cant-Qty-Q.ta										6 BB 8016									
			1- M26- 2 ST3B 2- M26- 4 ST3B 3- M30- 2 ST3B 4- M30- 4 ST3B 5- M40- 2 ST3B 6- M40- 4 ST3B 7- M50- 2 ST3B 8- M50- 4 ST3B 9- M26- 2H ST3B 10-M26- 4H ST3B										11 - M30- 2H ST3B 12 - M30- 4H ST3B 13 - M40- 2H ST3B 14 - M40- 4H ST3B 15 - M50- 2H ST3B 16 - M50- 4H ST3B 17 - 18 - 19 - 20 -									
			1	2	3	4	5	6	7	8	9	10	11	12	13	14	15	16	17	18	19	20
12	551259	Faisceau Haz Fascio - Kabelbaum - Wiring harness	1	1	1	1	1	1	1	1												
13	78088	Soufflet Fuelle Soffietto - Blasebalg - Bellows	1	1	1	1	1	1	1	1												
14	218735	Plaque de fixation Placa de fijación Piastra di fissaggio - Befestigung Platte - Fastening plate	1	1	1	1	1	1	1	1												
15	189172	Vis CBHc,M 6-16-10.9-ZN5/NOIR Tornillo Vite - Schraube - Screw	4	4	4	4	4	4	4	4												
16	189857	Rondelle M6 ZN PASS.NOIRE Arandela Rondella - Unterlegscheibe - Washer	4	4	4	4	4	4	4	4												

M

7 AA 8017

ESSIEU ARRIERE
HINTERACHSE
EJE TRASERO
REAR AXLE
PONTE POSTERIORE

M 26-2 ST3B M 26-2H ST3B
M 30-2 ST3B M 30-2H ST3B

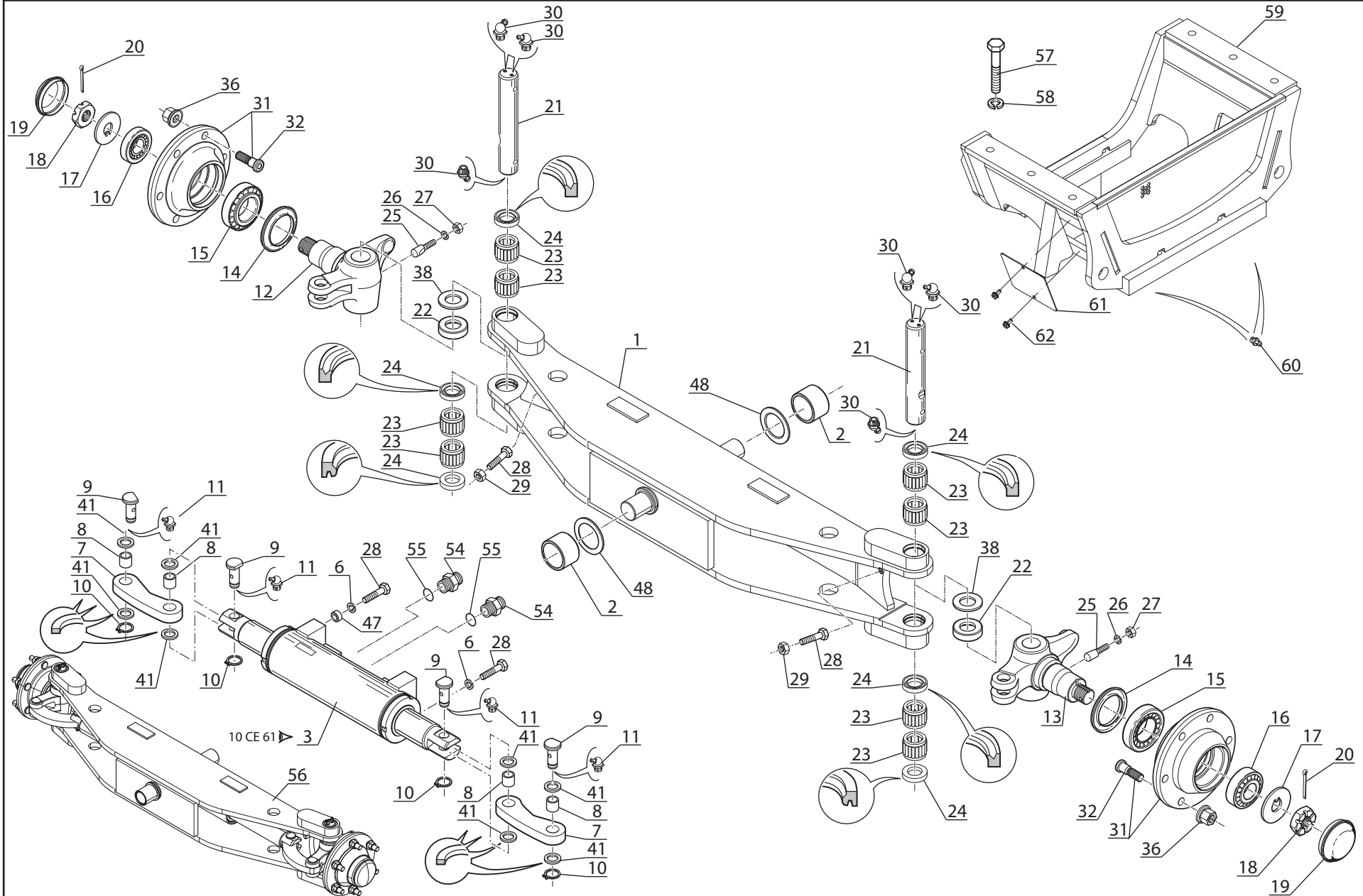

Catalogue : 647483

1	ESSIEU ARRIERE HINTERACHSE EJE TRASERO REAR AXLE PONTE POSTERIORE			Qte-Menge-Cant-Qty-Q.ta										7 AA 8017									
	Rep Hinw Fig Item Rif	Numéro Teil-Nr Numero Part-Nr Part-Nr	Désignation Bezeichnung Descripcion Description Descrizione	1	2	3	4	5	6	7	8	9	10	11	12	13	14	15	16	17	18	19	20
1	256859	Essieu arrière Eje trasero Assale posteriore	- Hinterachse - Rear axle	1		1						1		1									
2	51314F203071	Bague Anillo Anello	- Büchse - Bushing	2		2						2		2									
3	256867	Vérin Cilindro Cilindro	- Zylinder - Cylinder	1		1						1		1									
6	194287	Rondelle M16 ZN160HV Arandela Rondella	- Unterlegscheibe - Washer	4		4						4		4									
7	256865	Biellette de direction Biela de dirección Biella di sterzo	- Lenkstange - Steering rod	2		2						2		2									
8	211302	Bague Anillo Anello	- Büchse - Bushing	4		4						4		4									
9	211281	Axe Eje Perno	- Bolzen - Pin	4		4						4		4									
10	37500	Circlips Aro retén Anello elastico	- Sicherungsring - Circlip	4		4						4		4									
11	81362	Graiss. coudé (M6x100) Engrasador acodado Ingrassatore	- Gekröpf schmiernippel - Cranked greaser	4		4						4		4									
12	214542	Fusée de direct. gauche Mangueta de direc. izqu. Fuso di direzione senestra	- Link achsschenkel - L.H. stub axle	1		1						1		1									
13	214543	Fusée de direct. droite Mangueta de direc. der. Fuso di direzione destra	- Recht achsschenkel - R.H. stub axle	1		1						1		1									

+

M

Catalogue : 647483

2	ESSIEU ARRIERE HINTERACHSE EJE TRASERO REAR AXLE PONTE POSTERIORE			Qte-Menge-Cant-Qty-Q.ta										7 AA 8017									
	Rep Hinw Fig Item Rif	Numéro Teil-Nr Numero Part-Nr Part-Nr	Désignation Bezeichnung Descripcion Description Descrizione	1	2	3	4	5	6	7	8	9	10	11	12	13	14	15	16	17	18	19	20
14	201951	Joint d'étanchéité Junta de estanqueidad Guarnizióne	- Dichtungsring - Seal	2		2						2		2									
15	211305	Roulement Rodamiento Cuscinetto	- Läger - Bearing	2		2						2		2									
16	211306	Roulement Rodamiento Cuscinetto	- Läger - Bearing	2		2						2		2									
17	211288	Rondelle SP Arandela Rondella	- Unterlegscheibe - Washer	2		2						2		2									
18	77260	Ecrou HK,M38-150 U Tuerca Dado	- Mutter - Nut	2		2						2		2									
19	201959	Chapeau de moyeu Tapadera de cubo Capello	- Radnabenkappe - Wheel hub cap	2		2						2		2									
20	61217	Goupille Pasador Spina	- Stift - Pin	2		2						2		2									
21	211285	Axe d'articulation Eje de articulación Perno di articolazione	- Gelenkachse - Articulating pin	2		2						2		2									
22	211307	Roulement Rodamiento Cuscinetto	- Läger - Bearing	2		2						2		2									
23	211308	Roulement Rodamiento Cuscinetto	- Läger - Bearing	8		8						8		8									
24	211309	Joint d'étanchéité Junta de estanqueidad Guarnizióne	- Dichtungsring - Seal	6		6						6		6									

M

+

Catalogue : 647483

Rep Hinw Fig Item Rif	Numéro Teil-Nr Numero Part-Nr Part-Nr	Désignation Bezeichnung Descripcion Description Descrizione	Qte-Menge-Cant-Qty-Q.ta										7 AA 8017									
			1	2	3	4	5	6	7	8	9	10	11	12	13	14	15	16	17	18	19	20
			25	4311235010	Axe de blocage Eje de bloqueo Perno di bloccaggio	- Sicherungsachse - Locking pin	2		2						2		2					
26	42232	Rondelle W10 ZN Arandela Rondella	- Unterlegscheibe - Washer	2		2						2		2								
27	164633	Ecrou H,M10Pas125zingué Tuerca Dado	- Mutter - Nut	2		2						2		2								
28	61308	Vis H,M16-50-8.8-ZN8/C Tornillo Vite	- Schraube - Screw	6		6						6		6								
29	18422	Ecrou Hm, M16 zingué Tuerca Dado	- Mutter - Nut	2		2						2		2								
30	22254	Graisseur (6x100C)45° Engrasador Ingrassatore	- Schmiernippel - Greaser	6		6						6		6								
31	264393	Moyeu de roue complet Cubo de rueda comp. Mozzo ruota completo	- Kompletter radnabe - Complete wheel hub	2		2						2		2								
32	264392	Goujon Espárrago Prigioniero	- Stiftschraube - Stud-bolt	12		12						12		12								
36	247292	Ecrou de roue Tuerca de rueda Dado ruote	- Radmutter - Wheel nut	12		12						12		12								
38	211313	Rondelle SP40,5x70x0,1 Arandela Rondella	- Unterlegscheibe - Washer	X		X						X		X								
38	211314	Rondelle SP40,5x70x0,2 Arandela Rondella	- Unterlegscheibe - Washer	X		X						X		X								

M

+

Catalogue : 647483

4	ESSIEU ARRIERE HINTERACHSE EJE TRASERO REAR AXLE PONTE POSTERIORE			Qte-Menge-Cant-Qty-Q.ta										7 AA 8017									
	Rep Hinw Fig Item Rif	Número Teil-Nr Numero Part-Nr Part-Nr	Désignation Bezeichnung Descripcion Description Descrizione	1	2	3	4	5	6	7	8	9	10	11	12	13	14	15	16	17	18	19	20
38	211315	Rondelle SP405x 70x0,5 Arandela Rondella	- Unterlegscheibe - Washer	X		X						X		X									
41	432161011071	Rondelle SP28,5x50x0,5 Arandela Rondella	- Unterlegscheibe - Washer	X		X						X		X									
41	432171011071	Rondelle SP28,5x50x1 Arandela Rondella	- Unterlegscheibe - Washer	X		X						X		X									
41	9056428030	Cale d'épaisseur0,1mm Cala de espesor Spessore	- Ausgleichscheibe - Shim	X		X						X		X									
41	9056428031	Cale d'épaisseur0,2mm Cala de espesor Spessore	- Ausgleichscheibe - Shim	X		X						X		X									
47	200317	Pion de centrage Espiga de centraje Spina	- Zentrierstift - Centering pin	2		2						2		2									
48	209552	Cale d'épaisseur 3mm Cala de espesor Spessore	- Ausgleichscheibe - Shim	X		X						X		X									
48	209553	Cale d'épaisseur 3,5mm Cala de espesor Spessore	- Ausgleichscheibe - Shim	X		X						X		X									
48	209554	Cale d'épaisseur 4mm Cala de espesor Spessore	- Ausgleichscheibe - Shim	X		X						X		X									
48	209555	Cale d'épaisseur 4,5mm Cala de espesor Spessore	- Ausgleichscheibe - Shim	X		X						X		X									
48	209556	Cale d'épaisseur 5mm Cala de espesor Spessore	- Ausgleichscheibe - Shim	X		X						X		X									

M

+

Catalogue : 647483

5	ESSIEU ARRIERE HINTERACHSE EJE TRASERO REAR AXLE PONTE POSTERIORE			Qte-Menge-Cant-Qty-Q.ta										7 AA 8017									
	Rep Hinw Fig Item Rif	Numéro Teil-Nr Numero Part-Nr Part-Nr	Désignation Bezeichnung Descripcion Description Descrizione	1	2	3	4	5	6	7	8	9	10	11	12	13	14	15	16	17	18	19	20
48	209557	Cale d'épaisseur 5,5mm Cala de espesor Spessore	- Ausgleichscheibe - Shim	X		X						X		X									
54	167927	Raccord Union Racor Raccordo	- Verschraubung - Connection	2		2						2		2									
55	169436	Joint torique Junta tórica Anello OR	- "0" ring - "0" ring	X		X						X		X									
56	256858	Essieu arrière Eje trasero Assale posteriore	- Hinterachse - Rear axle	1		1						1		1									
57	31010	Vis H,M18- 60 zinguée Tornillo Vite	- Schraube - Screw	6		6						6		6									
58	42703	Rondelle W18 ZN Arandela Rondella	- Unterlegscheibe - Washer	6		6						6		6									
59	51300516	Support essieu Soporte eje Supporto assale	- Achse träger - Axle bracket	1		1						1		1									
60	269	Graisseur Engrasador Ingrassatore	- Schmiernippel - Greaser	2		2						2		2									
61	51300715	Couvercle Tapadera Coperchio	- Deckel - Cover	1		1						1		1									
62	259946	Vis Tornillo Vite	- Schraube - Screw	2		2						2		2									

M

7 AA 8018

SUPPORT ESSIEU ARRIERE
HINTERACHSE TRAGER
SOPORTE EJE TRASERO
REAR AXLE BRACKET
SUPPORTO PONTE POSTERIORE

M 26-4 ST3B M 26-4H ST3B
M 30-4 ST3B M 30-4H ST3B

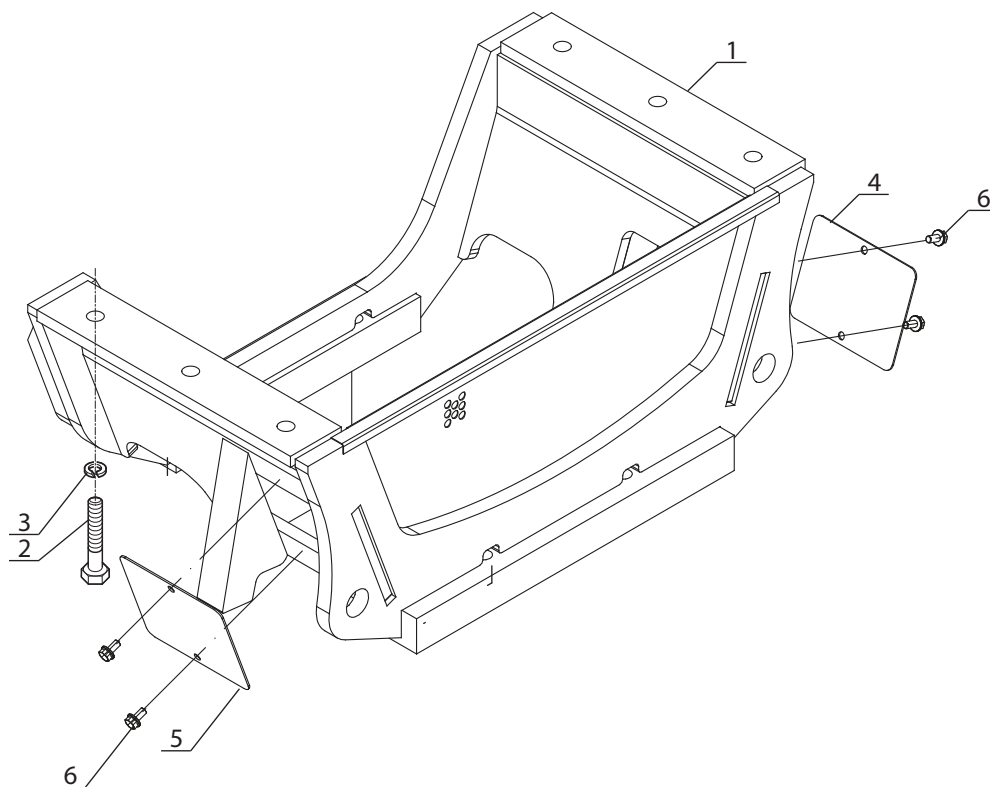

Catalogue : 647483

1	SUPPORT ESSIEU ARRIERE HINTERACHSE TRAGER SOPORTE EJE TRASERO REAR AXLE BRACKET SUPPORTO PONTE POSTERIORE			Qte-Menge-Cant-Qty-Q.ta										7 AA 8018									
	Rep Hinw Fig Item Rif	Numéro Teil-Nr Numero Part-Nr Part-Nr	Désignation Bezeichnung Descripcion Description Descrizione	1	2	3	4	5	6	7	8	9	10	11	12	13	14	15	16	17	18	19	20
1	51300505	Support essieu arrière Soporte eje trasero Supporto assale post.	- Hinterachse träger - Rear axle bracket		1		1					1		1									
2	31010	Vis H,M18- 60 zinguée Tornillo Vite	- Schraube - Screw		6		6					6		6									
3	42703	Rondelle W18 ZN Arandela Rondella	- Unterlegscheibe - Washer		6		6					6		6									
4	51300712	Couvercle droit Tapadera Coperchio	- Deckel - Cover right		1		1					1		1									
5	51300711	Couvercle gauche Tapadera Coperchio	- Deckel - Cover left		1		1					1		1									
6	259946	Vis zinguée Tornillo Vite	- Schraube - Screw		4		4					4		4									
7																							
8																							
9																							
10																							
11																							

M

7 AA 8019

SUPPORT ESSIEU ARRIERE
HINTERACHSE TRAGER
SOPORTE EJE TRASERO
REAR AXLE BRACKET
SUPPORTO PONTE POSTERIORE

**M 40-4 ST3B
M 50-4 ST3B**

**M 40-4H ST3B
M 50-4H ST3B**

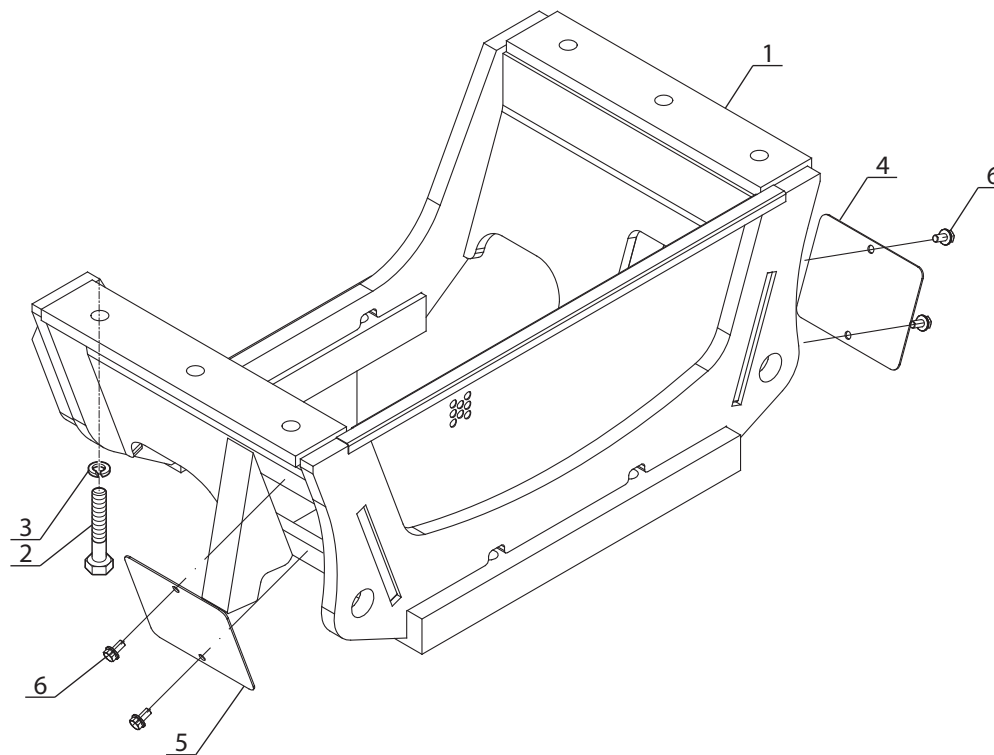

Catalogue : 647483

1	SUPPORT ESSIEU ARRIERE HINTERACHSE TRAGER SOPORTE EJE TRASERO REAR AXLE BRACKET SUPPORTO PONTE POSTERIORE			Qte-Menge-Cant-Qty-Q.ta										7 AA 8019									
	Rep Hinw Fig Item Rif	Numéro Teil-Nr Numero Part-Nr Part-Nr	Désignation Bezeichnung Descripcion Description Descrizione	1	2	3	4	5	6	7	8	9	10	11	12	13	14	15	16	17	18	19	20
1	51300492	Support essieu arrière Soporte eje trasero Supporto assale post.	- Hinterachse träger - Rear axle bracket						1		1						1		1				
2	31010	Vis H,M18- 60 zinguée Tornillo Vite	- Schraube - Screw						6		6						6		6				
3	42703	Rondelle W18 ZN Arandela Rondella	- Unterlegscheibe - Washer						6		6						6		6				
4	51300714	Couvercle droit Tapadera Coperchio	- Deckel - Cover right						1		1						1		1				
5	51300713	Couvercle gauche Tapadera Coperchio	- Deckel - Cover left						1		1						1		1				
6	259946	Vis zinguée Tornillo Vite	- Schraube - Screw						4		4						4		4				

M

7 AA 8020

ESSIEU ARRIERE
HINTERACHSE
EJE TRASERO
REAR AXLE
PONTE POSTERIORE

M 40-2 ST3B
M 50-2 ST3B

M 40-2H ST3B
M 50-2H ST3B

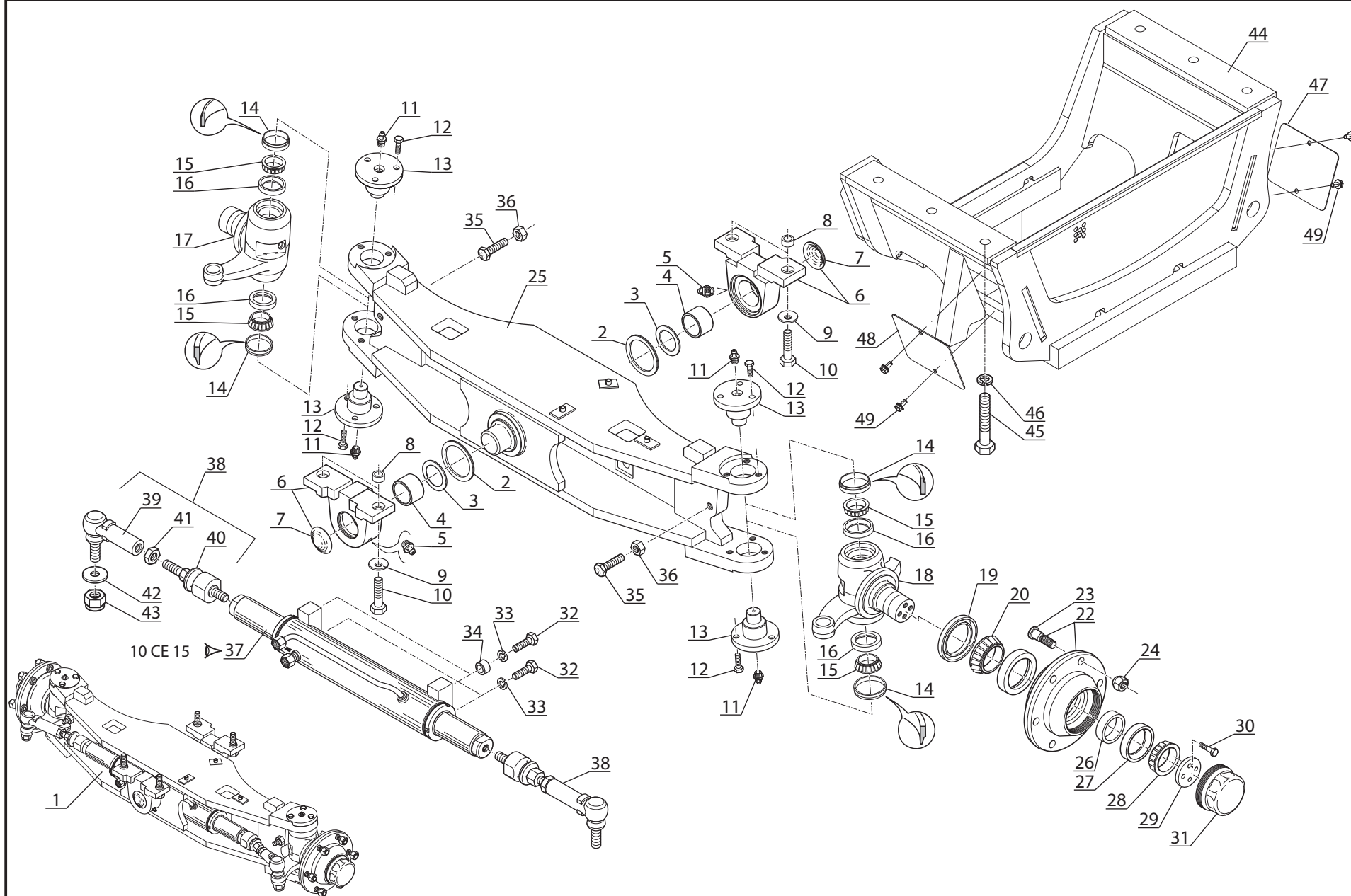

Catalogue : 647483

Rep Hinw Fig Item Rif	Numéro Teil-Nr Numero Part-Nr Part-Nr	Désignation Bezeichnung Descripcion Description Descrizione	Qte-Menge-Cant-Qty-Q.ta										7 AA 8020									
			1	2	3	4	5	6	7	8	9	10	11	12	13	14	15	16	17	18	19	20
			1	252242	Essieu arrière comp. Eje trasero. Assale posteriore comp.	- Kompletter Hinterachse - Rear axle																
2	203567	Joint d'étanchéité Junta de estanqueidad Guarnizióne	- Dichtungsring - Seal																			
3	203516	RondelleSP65,5x93x3PA6 Arandela Rondella	- Unterlegscheibe - Washer																			
3	203517	RondelleSP65,5x93x3,5PA6 Arandela Rondella	- Unterlegscheibe - Washer																			
3	203518	Rondelle SP65,5x93x4PA6 Arandela Rondella	- Unterlegscheibe - Washer																			
4	203515	Bague Anillo Anello	- Büchse - Bushing																			
5	51534	Graisser droit Engrasador recto Ingrassatore destro	- Gerade schmiernippel - Straight greaser																			
6	206698	Palier Cojinete Cuscinetti	- Lager - Bearing																			
7	205013	Bouchon Tapón Tappo	- Stopfen - Plug																			
8	246073	Pion de centrage Espiga de centraje Perno di centraggio	- Zentrierstift - Centering pin																			
9	36131	Rondelle ELAST 21x40x3ZN Arandela Rondella	- Unterlegscheibe - Washer																			

+

Catalogue : 647483

2	ESSIEU ARRIERE HINTERACHSE EJE TRASERO REAR AXLE PONTE POSTERIORE			Qte-Menge-Cant-Qty-Q.ta										7 AA 8020																																																																																																																																																																																																																	
	Rep Hinw Fig Item Rif	Numéro Teil-Nr Numero Part-Nr Part-Nr	Désignation Bezeichnung Descricion Description Descrizione	<table border="0"> <tr> <td>1- M26- 2 ST3B</td> <td>11 - M30- 2H ST3B</td> <td></td><td></td><td></td><td></td><td></td><td></td><td></td><td></td><td></td><td></td><td></td><td></td><td></td><td></td><td></td><td></td><td></td><td></td> </tr> <tr> <td>2- M26- 4 ST3B</td> <td>12 - M30- 4H ST3B</td> <td></td><td></td><td></td><td></td><td></td><td></td><td></td><td></td><td></td><td></td><td></td><td></td><td></td><td></td><td></td><td></td><td></td><td></td> </tr> <tr> <td>3- M30- 2 ST3B</td> <td>13 - M40- 2H ST3B</td> <td></td><td></td><td></td><td></td><td></td><td></td><td></td><td></td><td></td><td></td><td></td><td></td><td></td><td></td><td></td><td></td><td></td><td></td> </tr> <tr> <td>4- M30- 4 ST3B</td> <td>14 - M40- 4H ST3B</td> <td></td><td></td><td></td><td></td><td></td><td></td><td></td><td></td><td></td><td></td><td></td><td></td><td></td><td></td><td></td><td></td><td></td><td></td> </tr> <tr> <td>5- M40- 2 ST3B</td> <td>15 - M50- 2H ST3B</td> <td></td><td></td><td></td><td></td><td></td><td></td><td></td><td></td><td></td><td></td><td></td><td></td><td></td><td></td><td></td><td></td><td></td><td></td> </tr> <tr> <td>6- M40- 4 ST3B</td> <td>16 - M50- 4H ST3B</td> <td></td><td></td><td></td><td></td><td></td><td></td><td></td><td></td><td></td><td></td><td></td><td></td><td></td><td></td><td></td><td></td><td></td><td></td> </tr> <tr> <td>7- M50- 2 ST3B</td> <td>17 -</td> <td></td><td></td><td></td><td></td><td></td><td></td><td></td><td></td><td></td><td></td><td></td><td></td><td></td><td></td><td></td><td></td><td></td><td></td> </tr> <tr> <td>8- M50- 4 ST3B</td> <td>18 -</td> <td></td><td></td><td></td><td></td><td></td><td></td><td></td><td></td><td></td><td></td><td></td><td></td><td></td><td></td><td></td><td></td><td></td><td></td> </tr> <tr> <td>9- M26- 2H ST3B</td> <td>19 -</td> <td></td><td></td><td></td><td></td><td></td><td></td><td></td><td></td><td></td><td></td><td></td><td></td><td></td><td></td><td></td><td></td><td></td><td></td> </tr> <tr> <td>10-M26- 4H ST3B</td> <td>20 -</td> <td></td><td></td><td></td><td></td><td></td><td></td><td></td><td></td><td></td><td></td><td></td><td></td><td></td><td></td><td></td><td></td><td></td><td></td> </tr> </table>																				1- M26- 2 ST3B	11 - M30- 2H ST3B																			2- M26- 4 ST3B	12 - M30- 4H ST3B																			3- M30- 2 ST3B	13 - M40- 2H ST3B																			4- M30- 4 ST3B	14 - M40- 4H ST3B																			5- M40- 2 ST3B	15 - M50- 2H ST3B																			6- M40- 4 ST3B	16 - M50- 4H ST3B																			7- M50- 2 ST3B	17 -																			8- M50- 4 ST3B	18 -																			9- M26- 2H ST3B	19 -																			10-M26- 4H ST3B	20 -																		
				1- M26- 2 ST3B	11 - M30- 2H ST3B																																																																																																																																																																																																																										
2- M26- 4 ST3B	12 - M30- 4H ST3B																																																																																																																																																																																																																														
3- M30- 2 ST3B	13 - M40- 2H ST3B																																																																																																																																																																																																																														
4- M30- 4 ST3B	14 - M40- 4H ST3B																																																																																																																																																																																																																														
5- M40- 2 ST3B	15 - M50- 2H ST3B																																																																																																																																																																																																																														
6- M40- 4 ST3B	16 - M50- 4H ST3B																																																																																																																																																																																																																														
7- M50- 2 ST3B	17 -																																																																																																																																																																																																																														
8- M50- 4 ST3B	18 -																																																																																																																																																																																																																														
9- M26- 2H ST3B	19 -																																																																																																																																																																																																																														
10-M26- 4H ST3B	20 -																																																																																																																																																																																																																														
1	2	3	4	5	6	7	8	9	10	11	12	13	14	15	16	17	18	19	20																																																																																																																																																																																																												
10	56719	Vis H,M20-70-8.8-ZN8/C Tornillo Vite	- Schraube - Screw			4		4						4				4																																																																																																																																																																																																													
11	51534	Graisseeur droit Engrasador recto Ingrassatore destro	- Gerade schmiernippel - Straight greaser			4		4					4					4																																																																																																																																																																																																													
12	487197	VisH,M14-40-10.9-ZN8/C Tornillo Vite	- Schraube - Screw					12						12				12																																																																																																																																																																																																													
13	220773	Axe Eje Perno	- Bolzen - Pin			4		4					4					4																																																																																																																																																																																																													
14	203568	Joint d'étanchéité Junta d estanqueidad Guarnizione	- Dichtungsring Seal			4		4					4					4																																																																																																																																																																																																													
15	220776	Roulement Rodamiento Cuscinetto	- Läger - Bearing			4		4					4					4																																																																																																																																																																																																													
16	220777	Bague Anillo Anello	- Büchse - Bushing			4		4					4					4																																																																																																																																																																																																													
17	220774	Fusée de direc. gauche Mangueta de direc. izq. Fuso di direzione	- Link achsschenkel - L.H. stub axle			1		1					1					1																																																																																																																																																																																																													
18	220775	Fusée de direc. droite Mangueta de direc. derecha Fuso di direzione destra	- Recht achsschenkel - R.H. stub axle			1		1					1					1																																																																																																																																																																																																													
19	201951	Joint d'étanchéité Junta de estanqueidad Guarnizione	- Dichtungsring - Seal			2		2					2					2																																																																																																																																																																																																													
20	201961	Roulement Rodamiento Cuscinetto	- Läger - Bearing			2		2					2					2																																																																																																																																																																																																													

M

+

Catalogue : 647483

Rep Hinw Fig Item Rif	Numéro Teil-Nr Numero Part-Nr Part-Nr	Désignation Bezeichnung Descripcion Description Descrizione	Qte-Menge-Cant-Qty-Q.ta										7 AA 8020									
			1	2	3	4	5	6	7	8	9	10	11	12	13	14	15	16	17	18	19	20
			21	201960	Bague Anillo Anello - BÜchse - Bushing					2		2						2		2		
22	264394	Moyeu de roue comp. Cubo de rueda completo Mozzo ruota completo - Kompletter radnabe - Complete wheel hub					2		2					2		2						
23	264392	Goujon Espárrago Prigioniero - Stiftschraube - Stud-bolt					12		12					12		12						
24	1767	Ecrou de roue Tuerca de rueda Dado ruote - Radmutter - Wheel nut					12		12					12		12						
25	252241	Essieu arrière Eje trasero Assale posteriore - Hinterachse - Rear axle					1		1					1		1						
26	201949	Entretoise Separador Distanziale - Querstrebe - Spacer					2		2					2		2						
27	201962	Bague Anillo Anello - BÜchse - Bushing					2		2					2		2						
28	201963	Roulement Rodamiento Cuscinetto - LÄger - Bearing					2		2					2		2						
29	201948	Rondelle Arandela Rondella - Unterlegscheibe - Washer					2		2					2		2						
30	43789	VisH,M12-40-10.9-ZN8/C Tornillo Vite - Schraube - Screw					8		8					8		8						
31	201959	Chapeau de moyeu Tapadera de cubo Capello - Radnabenkappe - Wheel hub cap					2		2					2		2						

M

+

Catalogue : 647483

4	ESSIEU ARRIERE HINTERACHSE EJE TRASERO REAR AXLE PONTE POSTERIORE			Qte-Menge-Cant-Qty-Q.ta										7 AA 8020									
	Rep Hinw Fig Item Rif	Numéro Teil-Nr Numero Part-Nr Part-Nr	Désignation Bezeichnung Descripcion Description Descrizione	1	2	3	4	5	6	7	8	9	10	11	12	13	14	15	16	17	18	19	20
				1- M26- 2 ST3B	11 - M30- 2H ST3B																		
				2- M26- 4 ST3B	12 - M30- 4H ST3B																		
				3- M30- 2 ST3B	13 - M40- 2H ST3B																		
				4- M30- 4 ST3B	14 - M40- 4H ST3B																		
				5- M40- 2 ST3B	15 - M50- 2H ST3B																		
				6- M40- 4 ST3B	16 - M50- 4H ST3B																		
				7- M50- 2 ST3B	17 -																		
				8- M50- 4 ST3B	18 -																		
				9- M26- 2H ST3B	19 -																		
				10-M26- 4H ST3B	20 -																		
32	61308	Vis H,M16-50-8.8-ZN8/C Tornillo Vite	- Schraube - Screw					4		4						4		4					
33	42322	Rondelle W16 ZN Arandela Rondella	- Unterlegscheibe - Washer					4		4						4		4					
34	200317	Pion de centrage Espiga de centraje Spina	- Zentrierstift - Centering pin					2		2						2		2					
35	203524	Butée Tope Battuta	- Anschlag - Stop					2		2						2		2					
36	32110	Ecrou Hm, M18 zingué Tuerca Dado	- Mutter - Nut					2		2						2		2					
37	200316	Vérin de direction Cil. de dirección Cilindro di sterzo	- Lenkzylinder - Steering cylinder					1		1						1		1					
38	229433	Barre d'accouplement Barra de acoplamiento Barra de accoppiamento	- Spurstange - Cross rod					2		2						2		2					
39	600750	Rotule Rótula Rotula	- Kugelgelenk - Knee-joint					2		2						2		2					
40	600751	Tirant Tirante Tiranti	- Stange - Tie bar					2		2						2		2					
41	600752	Ecrou Tuerca Dado	- Mutter - Nut					2		2						2		2					
42	61683	Rondelle M 20 ZN 160HV Arandela Rondella	- Unterlegscheibe - Washer					2		2						2		2					

M

+

Catalogue : 647483

5	ESSIEU ARRIERE HINTERACHSE EJE TRASERO REAR AXLE PONTE POSTERIORE			Qte-Menge-Cant-Qty-Q.ta										7 AA 8020									
	Rep Hinw Fig Item Rif	Numéro Teil-Nr Numero Part-Nr Part-Nr	Désignation Bezeichnung Descripcion Description Descrizione	1	2	3	4	5	6	7	8	9	10	11	12	13	14	15	16	17	18	19	20
43	86832	Ecrou H,FR M20 zingué Tuerca Dado	- Mutter - Nut					2		2						2		2					
44	51300492	Support essieu arrière Soporte eje trasero Supporto assale post.	- Hinterachse träger - Rear axle bracket					1		1						1		1					
45	31010	Vis H,M18- 60 zinguée Tornillo Vite	- Schraube - Screw					6		6						6		6					
46	42703	Rondelle W18 ZN Arandela Rondella	- Unterlegscheibe - Washer					6		6						6		6					
47	51300714	Couvercle Droit Tapadera derecha Coperchio	- Deckel - Cover right					1		1						1		1					
48	51300713	Couvercle gauche Tapadera Iazq. Coperchio	- Deckel - Cover right					1		1						1		1					
49	259646	Vis H,M16-50-8.8-ZN8/C Tornillo Vite	- Schraube - Screw					4		4						4		4					

M

8 AA 8021

SIEGE (Skai) (CDS)
SITZ (Synthetisch stoff) (CDS)
ASIENTO (Tejido sintético) (CDS)
SEAT (Synthetics woven) (CDS)
SEDILE (In sky) (CDS)

M 26-2/4 ST3B	M 26-2/4H ST3B
M 30-2/4 ST3B	M 30-2/4H ST3B
M 40-2/4 ST3B	M 40-2/4H ST3B
M 50-2/4 ST3B	M 50-2/4H ST3B

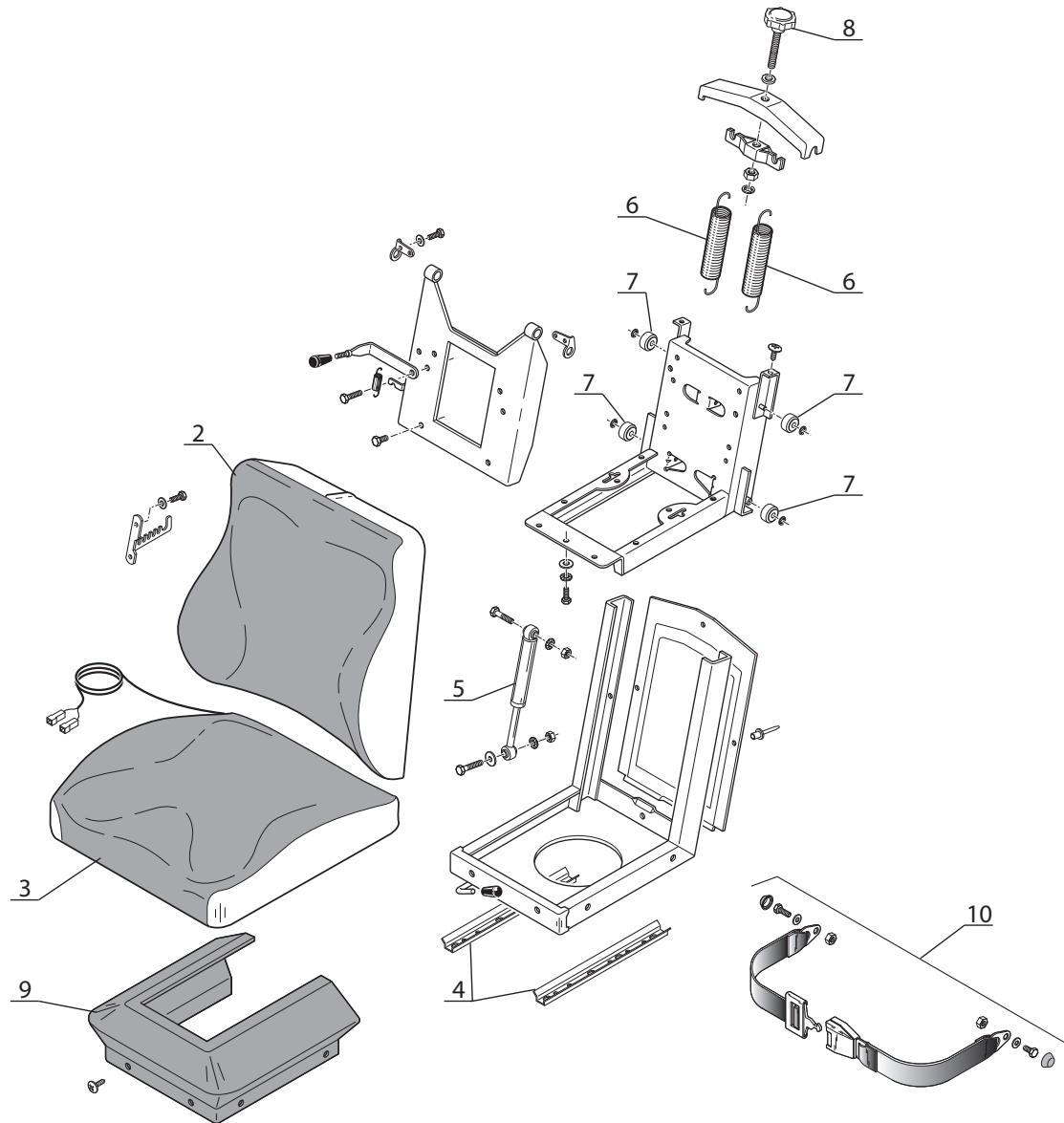
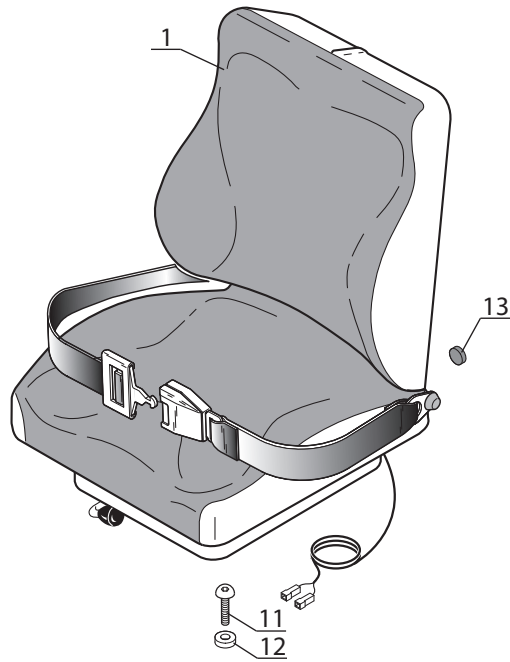

Catalogue : 647483

1	SIEGE (Skai) (CDS) SITZ (Synthetisch stoff) (CDS) ASIENTO (Tejido sintetico) (CDS) SEAT (Synthetics woven) (CDS) SEDILE (In sky) (CDS)			Qte-Menge-Cant-Qty-Q.ta										8 AA 8021									
	Rep Hinw Fig Item Rif	Numéro Teil-Nr Numero Part-Nr Part-Nr	Désignation Bezeichnung Descripcion Description Descrizione	1	2	3	4	5	6	7	8	9	10	11	12	13	14	15	16	17	18	19	20
1	219825	Siège complet Asiento completo Sedile completo	- Kompletter sitz - Complete seat	1	1	1	1	1	1	1	1	1	1	1	1	1	1	1	1				
2	476301	Dossier complet Espalda de asiento Schienale completo	- Verstellbarelehne - Seat back	1	1	1	1	1	1	1	1	1	1	1	1	1	1	1	1				
3	706094	Coussin complet Asiento completo Cuscino completo	- Kompletter sitz - Seat cushion assembly	1	1	1	1	1	1	1	1	1	1	1	1	1	1	1	1				
4	476983	Jeu de glissières Juego de deslizador Kit slitta	- Gleitschiene satz - Kit of slides	1	1	1	1	1	1	1	1	1	1	1	1	1	1	1	1				
5	476924	Amortisseur Amortiguador Ammortizzatore	- Dämpfer - Damper	1	1	1	1	1	1	1	1	1	1	1	1	1	1	1	1				
6	476984	Ressort Muelle Molla	- Feder - Spring	2	2	2	2	2	2	2	2	2	2	2	2	2	2	2	2				
7	476985	Bague Anillo Anello	- Büchse - Bushing	4	4	4	4	4	4	4	4	4	4	4	4	4	4	4	4				
8	476986	Poignée de rég. d poids Agarrador de réglaje de peso Manop. di regolazione del peso	- Gewicht einstell. handgrill - Weight adj. handle	1	1	1	1	1	1	1	1	1	1	1	1	1	1	1	1				
9	476987	Soufflet de protection Fuelle de protecció Soff. di protezione	- Unrafschutz satz - Suspension cover	1	1	1	1	1	1	1	1	1	1	1	1	1	1	1	1				
10	207300	Ceinture de sécurité Cinturon de segur. Cintura di sigurezza	- Sitz Gurt - Seat belt	1	1	1	1	1	1	1	1	1	1	1	1	1	1	1	1				
11	18805	Vis CHc,M 8-25 zinguée Tornillo Vite	- Schraube - Screw	4	4	4	4	4	4	4	4	4	4	4	4	4	4	4	4				

M

+

Catalogue : 647483

Rep Hinw Fig Item Rif	Numéro Teil-Nr Numero Part-Nr Part-Nr	Désignation Bezeichnung Descripcion Description Descrizione	Qte-Menge-Cant-Qty-Q.ta										8 AA 8021									
			1	2	3	4	5	6	7	8	9	10	11	12	13	14	15	16	17	18	19	20
			2		SIEGE (Skai) (CDS) SITZ (Synthetisch stoff) (CDS) ASIENTO (Tejido sintetico) (CDS) SEAT (Synthetics woven) (CDS) SEDILE (In sky) (CDS)	1- M26- 2 ST3B	2- M26- 4 ST3B	3- M30- 2 ST3B	4- M30- 4 ST3B	5- M40- 2 ST3B	6- M40- 4 ST3B	7- M50- 2 ST3B	8- M50- 4 ST3B	9- M26- 2H ST3B	10- M26- 4H ST3B	11 - M30- 2H ST3B	12 - M30- 4H ST3B	13 - M40- 2H ST3B	14 - M40- 4H ST3B	15 - M50- 2H ST3B	16 - M50- 4H ST3B	17 -
12	229220	Rondelle SP8,5x 26x10 Arandela Rondella	- Unterlegscheibe - Washer	4	4	4	4	4	4	4	4	4	4	4	4	4	4	4	4	4	4	4
13	184130	Butée Tope Battuta	- Anschlag - Stop	2	2	2	2	2	2	2	2	2	2	2	2	2	2	2	2	2	2	2

M

8 AA 8022

ADAPTATION CABINE (Poste de conduite)
KABINE ANPASSUNG (Fahrestand)
ADAPTACION CABINA (Puesto del conductor)
CAB ADAPTATION (Cab structure)
ADATTAMENTO CABINA (Posto di pilotaggio)

M 26-2/4 ST3B	M 26-2/4H ST3B
M 30-2/4 ST3B	M 30-2/4H ST3B
M 40-2/4 ST3B	M 40-2/4H ST3B
M 50-2/4 ST3B	M 50-2/4H ST3B

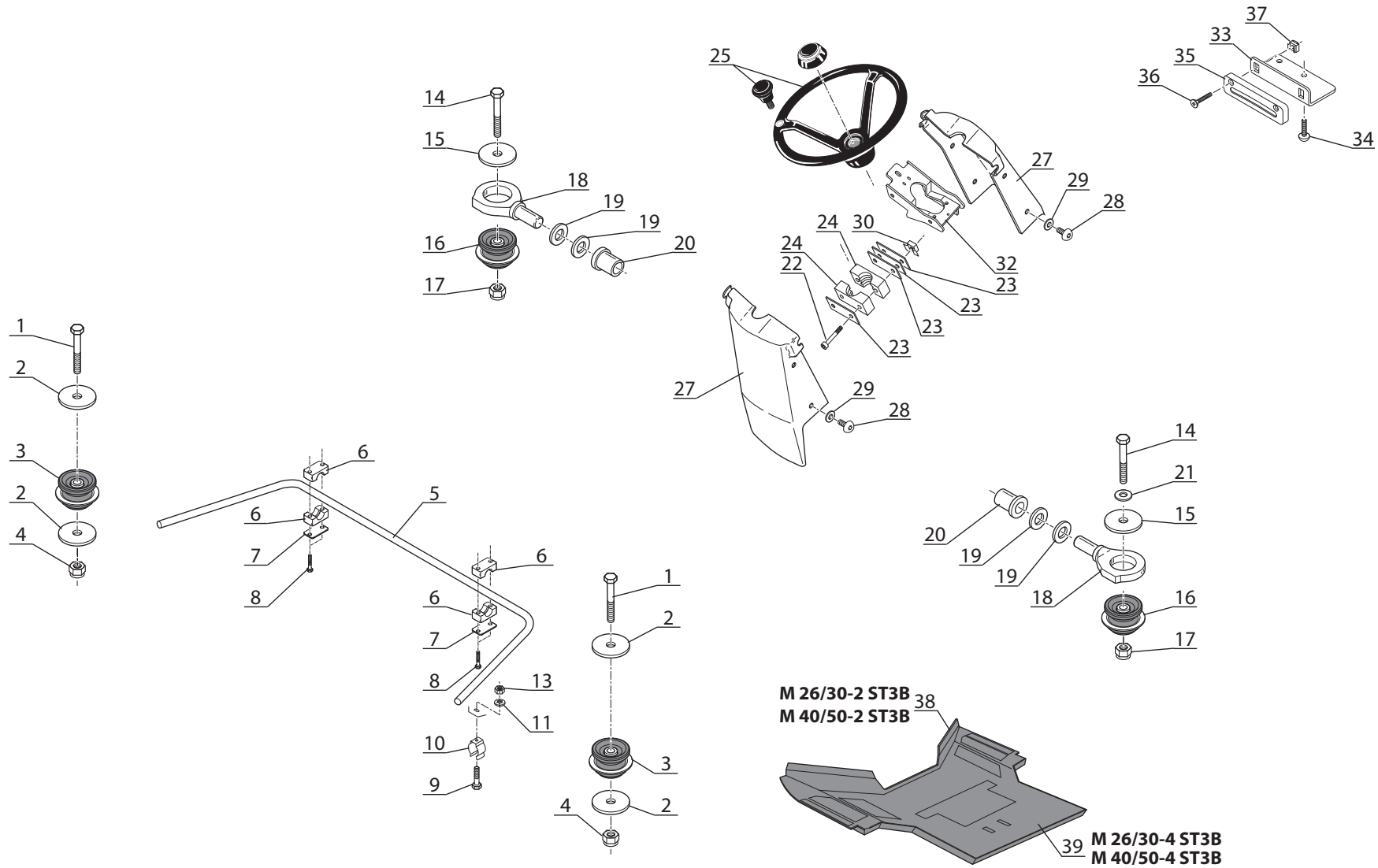

Catalogue : 647483

Rep Hinw Fig Item Rif	Numéro Teil-Nr Numero Part-Nr Part-Nr	Désignation Bezeichnung Descripcion Description Descrizione	Qte-Menge-Cant-Qty-Q.ta										8 AA 8022									
			1- M26- 2 ST3B 2- M26- 4 ST3B 3- M30- 2 ST3B 4- M30- 4 ST3B 5- M40- 2 ST3B 6- M40- 4 ST3B 7- M50- 2 ST3B 8- M50- 4 ST3B 9- M26- 2H ST3B 10-M26- 4H ST3B										11 - M30- 2H ST3B 12 - M30- 4H ST3B 13 - M40- 2H ST3B 14 - M40- 4H ST3B 15 - M50- 2H ST3B 16 - M50- 4H ST3B 17 - 18 - 19 - 20 -									
			1	2	3	4	5	6	7	8	9	10	11	12	13	14	15	16	17	18	19	20
1	168374	ADAPTATION CABINE (Poste de conduite) KABINE ANPASSUNG (Fahrestand) ADAPTACION CABINA (Puesto del conductor) CAB ADAPTATION (Cab structure) ADATTAMENTO CABINA (Posto di pilotaggio) Vis H,M20-110-8.8-ZN8/C Tornillo Vite - Schraube - Screw	2	2	2	2	2	2	2	2	2	2	2	2	2	2						
2	210006	Rondelle HR21x90x5ZN Arandela Rondella - Unterlegscheibe - Washer	4	4	4	4	4	4	4	4	4	4	4	4	4	4						
3	209113	Silentbloc Amortiguador Tasselo - Dampfer - Shock absorber	2	2	2	2	2	2	2	2	2	2	2	2	2	2						
4	185054	Ecrou H,FR M20 zingué Tuerca Dado - Mutter - Nut	2	2	2	2	2	2	2	2	2	2	2	2	2	2						
5	218367	Barre amovible Barra amovible Barra - Abnehmbarstange - Removable rod	1	1	1	1	1	1	1	1	1	1	1	1	1	1						
6	168488	Demi-collier Media abrazadera Fascetta - Halb-klemme - Half-clamp	4	4	4	4	4	4	4	4	4	4	4	4	4	4						
7	168491	Plaque de protection Placa de protección Piastra di protezione - Schützplatte - Protection plate	2	2	2	2	2	2	2	2	2	2	2	2	2	2						
8	29481	Vis H,M6-45-8.8-ZN5/C Tornillo Vite - Schraube - Screw	4	4	4	4	4	4	4	4	4	4	4	4	4	4						
9	4240	Vis H,M 5-16-8.8-ZN5/C Tornillo Vite - Schraube - Screw	1	1	1	1	1	1	1	1	1	1	1	1	1	1						
10	173355	Clip Clip Fermaglio - Klammer - Clip	1	1	1	1	1	1	1	1	1	1	1	1	1	1						
11	192310	Rondelle JZC5CAD.BICH Arandela Rondella - Unterlegscheibe - Washer	1	1	1	1	1	1	1	1	1	1	1	1	1	1						

+

Catalogue : 647483

Rep Hinw Fig Item Rif	Numéro Teil-Nr Numero Part-Nr Part-Nr	Désignation Bezeichnung Descripcion Description Descrizione	Qte-Menge-Cant-Qty-Q.ta										8 AA 8022									
			1	2	3	4	5	6	7	8	9	10	11	12	13	14	15	16	17	18	19	20
2		ADAPTATION CABINE (Poste de conduite) KABINE ANPASSUNG (Fahrestand) ADAPTACION CABINA (Puesto del conductor) CAB ADAPTATION (Cab structure) ADATTAMENTO CABINA (Posto di pilotaggio)	1- M26- 2 ST3B 2- M26- 4 ST3B 3- M30- 2 ST3B 4- M30- 4 ST3B 5- M40- 2 ST3B 6- M40- 4 ST3B 7- M50- 2 ST3B 8- M50- 4 ST3B 9- M26- 2H ST3B 10-M26- 4H ST3B										11 - M30- 2H ST3B 12 - M30- 4H ST3B 13 - M40- 2H ST3B 14 - M40- 4H ST3B 15 - M50- 2H ST3B 16 - M50- 4H ST3B 17 - 18 - 19 - 20 -									
13	54232	Ecrou H ,M5ZN Tuerca Dado - Mutter - Nut	1	1	1	1	1	1	1	1	1	1	1	1	1	1						
14	168374	Vis H,M20-110-8.8-ZN8/C Tornillo Vite - Schraube - Screw	2	2	2	2	2	2	2	2	2	2	2	2	2	2						
15	210006	Rondelle HR21x90x5ZN Arandela Rondella - Unterlegscheibe - Washer	2	2	2	2	2	2	2	2	2	2	2	2	2	2						
16	209113	Silentbloc Amortiguador Tasselo - Dampfer - Shock absorber	2	2	2	2	2	2	2	2	2	2	2	2	2	2						
17	185054	Ecrou H,FRM20 zingué Tuerca Dado - Mutter - Nut	2	2	2	2	2	2	2	2	2	2	2	2	2	2						
18	207783	Palier Cojinete Cuscinetti - Lager - Bearing	2	2	2	2	2	2	2	2	2	2	2	2	2	2						
19	202947	Rondelle Z30 ZN Arandela Rondella - Unterlegscheibe - Washer	4	4	4	4	4	4	4	4	4	4	4	4	4	4						
20	210005	Bague Anillo Anello - Büchse - Bushing	2	2	2	2	2	2	2	2	2	2	2	2	2	2						
21	61683	Rondelle M 20 ZN160HV Arandela Rondella - Unterlegscheibe - Washer	1	1	1	1	1	1	1	1	1	1	1	1	1	1						
22	165919	Vis H,M 6-80-8.8-ZN5/C Tornillo Vite - Schraube - Screw	2	2	2	2	2	2	2	2	2	2	2	2	2	2						
23	168870	Plaque de protection Placa de protección Piastra di protezione - Schützplatte - Protection plate	4	4	4	4	4	4	4	4	4	4	4	4	4	4						

M

+

Catalogue : 647483

3	ADAPTATION CABINE (Poste de conduite) KABINE ANPASSUNG (Fahrestand) ADAPTACION CABINA (Puesto del conductor) CAB ADAPTATION (Cab structure) ADATTAMENTO CABINA (Posto di pilotaggio)			Qte-Menge-Cant-Qty-Q.ta										8 AA 8022									
	Rep Hinw Fig Item Rif	Numéro Teil-Nr Numero Part-Nr Part-Nr	Désignation Bezeichnung Descripcion Description Descrizione																				
				1	2	3	4	5	6	7	8	9	10	11	12	13	14	15	16	17	18	19	20
24	174321	Demi-collier Ø38 Media abrazadera Fascetta	- Halb-klemme - Half-clamp	2	2	2	2	2	2	2	2	2	2	2	2	2	2						
25	191613	Volant de direction Volante de direccio Volante sterzo	- Lenkrad - Steering wheel	1	1	1	1	1	1	1	1	1	1	1	1	1	1						
26	195069	Chapeau de volant Tapadera de volante Capello sterzo	- Lenkradkappe - Steering wheel cap	1	1	1	1	1	1	1	1	1	1	1	1	1	1						
27	202953	Cache colonne de direct.(Avant) Funda col. de direcc.(Delantero) Coperchio col. sterzo(Anteriore)	- Lenksäule deckplatte(Vorn) - Steering col cov plte(Frnt)	1	1	1	1	1	1	1	1	1	1	1	1	1	1						
28	196951	Vis CBHc,M 6-12-10.9-ZN5/NOIR Tornillo Vite	- Schraube - Screw	8	8	8	8	8	8	8	8	8	8	8	8	8	8						
29	189857	Rondelle M6 ZN PASS.NOIRE Arandela Rondella	- Unterlegscheibe - Washer	8	8	8	8	8	8	8	8	8	8	8	8	8	8						
30	204665	Ecrou EQC M6D zingué Tuerca Dado	- Mutter - Nut	2	2	2	2	2	2	2	2	2	2	2	2	2	2						
31	202954	Cache colonne d direct(Arrière) Funda col.de direcc. (Trasero) Coperchio col. sterzo(Posteriore)	- Lenksäule deckplatt(Hinter) - Steering col cov pl (Rear)	1	1	1	1	1	1	1	1	1	1	1	1	1	1						
32	203115	Support commutateur d'éclairage Soporte conmutador de luces Supp. commutatore di illumin.	- Beleuchtungshalter träger - Lighting switch bracket	1	1	1	1	1	1	1	1	1	1	1	1	1	1						
33	246714	Support niveau à bulle d'air Soporte nivel de aire Supporto livello a bolla d'aria	- Libelle träger - Tubular sp. lev. bracket	1	1	1	1	1	1	1	1	1	1	1	1	1	1						

M

+

Catalogue : 647483

4	ADAPTATION CABINE (Poste de conduite) KABINE ANPASSUNG (Fahrestand) ADAPTACION CABINA (Puesto del conductor) CAB ADAPTATION (Cab structure) ADATTAMENTO CABINA (Posto di pilotaggio)			Qte-Menge-Cant-Qty-Q.ta										8 AA 8022									
	Rep Hinw Fig Item Rif	Numéro Teil-Nr Numero Part-Nr Part-Nr	Désignation Bezeichnung Descripcion Description Descrizione	1	2	3	4	5	6	7	8	9	10	11	12	13	14	15	16	17	18	19	20
34	205275	Vis CBHc,M 6- 20-10.9-ZN5/NOIR Tornillo Vite	- Schraube - Screw	2	2	2	2	2	2	2	2	2	2	2	2	2	2	2	2				
35	239337	Niveau à bulle d'air Nivel de aire Livello a bolla d'ari	- Libelle - Tubular spirit level	1	1	1	1	1	1	1	1	1	1	1	1	1	1	1	1				
36	61213	Vis FHc,M 4-20-10.9-ZN5/C Tornillo Vite	- Schraube - Screw	2	2	2	2	2	2	2	2	2	2	2	2	2	2	2	2				
37	407053	Ecrou cage Tuerca Dado	- Mutter - Nut	2	2	2	2	2	2	2	2	2	2	2	2	2	2	2	2				
38	221233	Tapis de sol Colchoneta dura Pedana	- Teppich - Carpet	1		1		1		1		1		1		1		1					
39	218852	Tapis de sol Colchoneta dura Pedana	- Teppich - Carpet		1		1		1		1		1		1		1		1				

M

PROTEGE-CONDUCTEUR
FÜHRER SCHUTZVORRICHTUNG
PROTECTOR CONDUCTOR
DRIVER'S OVERHEAD GUARD
PROTEZIONE CONDUCENTE

N° 309 842

8 AB 8058

POUR TYPE DE CABINE
FÜR KABINE TYPEN
PARA TIPO DE CABINA
FOR CAB TYPE
PER TIPO DI CABINA

PROTEGE-CONDUCTEUR (Détails)
FÜHRER SCHUTZVORRICHTUNG (Einzelteile)
PROTECTOR CONDUCTOR (Details)
DRIVER'S OVERHEAD GUARD (Details)
PROTEZIONE CONDUCENTE (Dettaglio)

M 26-2/4H ST3B
M 30-2/4H ST3B
M 40-2/4H ST3B
M 50-2/4H ST3B

CLÔTURE DU CABINE
CABIN GLATTSTELLUNG
CIERRE DE CABINA
CAB CLOSE OUT
CHIUSURA DEL CABINA

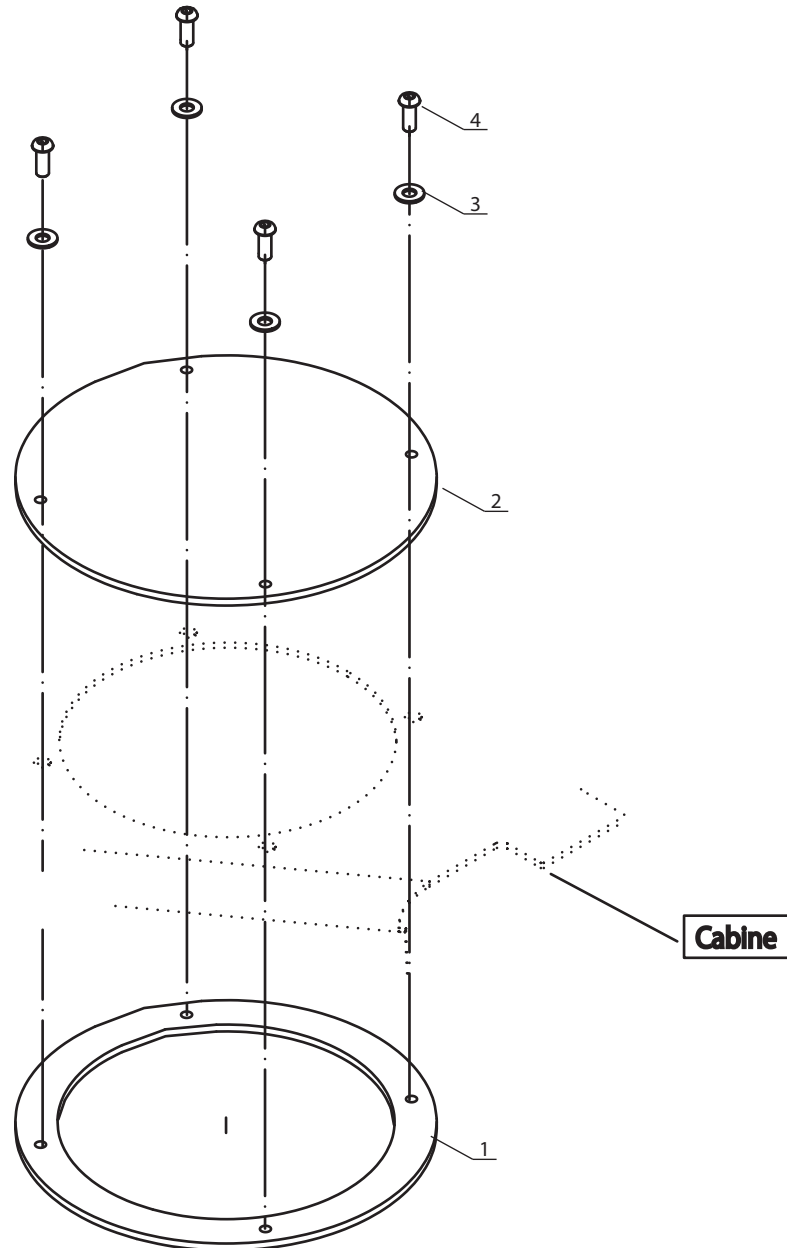

Catalogue : 647483

Qte-Menge-Cant-Qty-Q.ta | 8 AB 8058

M

1

CLÔTURE DU CABINE
CABIN GLATTSTELLUNG
CIERRE DE CABINA
CAB CLOSE OUT
CHIUSURA DEL CABINA

- | | |
|-----------------|-------------------|
| 1- M26- 2 ST3B | 11 - M30- 2H ST3B |
| 2- M26- 4 ST3B | 12 - M30- 4H ST3B |
| 3- M30- 2 ST3B | 13 - M40- 2H ST3B |
| 4- M30- 4 ST3B | 14 - M40- 4H ST3B |
| 5- M40- 2 ST3B | 15 - M50- 2H ST3B |
| 6- M40- 4 ST3B | 16 - M50- 4H ST3B |
| 7- M50- 2 ST3B | 17 - |
| 8- M50- 4 ST3B | 18 - |
| 9- M26- 2H ST3B | 19 - |
| 10-M26- 4H ST3B | 20 - |

Rep Hinw Fig Item Rif	Numéro Teil-Nr Numero Part-Nr Part-Nr	Désignation Bezeichnung Descripcion Description Descrizione	Qte-Menge-Cant-Qty-Q.ta																								
			1	2	3	4	5	6	7	8	9	10	11	12	13	14	15	16	17	18	19	20					
1	218735	Plaque Placa Piastra - Platte - Plate										1	1	1	1	1	1										
2	51300984	Bride Brida Flangia - Flansch - Flange										1	1	1	1	1	1	1									
3	189857	Rondelle M6 Zn12 Arandela Rondella - Unterlegscheibe - Washer										4	4	4	4	4	4	4									
4	189172	Vis CBHC, M 6-16 Tornillo Vite - Schraube - Screw										4	4	4	4	4	4	4									

8 AB 1409

POUR TYPE DE CABINE
FÜR KABINETYPEN
PARA TIPO DE CABINA
FOR CAB TYPE
PER TIPO DI CABINA
□ 309 842

PROTEGE-CONDUCTEUR (Détails)
FÜHRER SCHUTZVORRICHTUNG (Einzelteile)
PROTECTOR CONDUCTOR (Details)
DRIVER'S OVERHEAD GUARD (Details)
PROTEZIONE CONDUCENTE (Dettaglio)

M 26-2/4 ST3B
M 30-2/4 ST3B
M 40-2/4 ST3B
M 50-2/4 ST3B
M 26-2/4H ST3B
M 30-2/4H ST3B
M 40-2/4H ST3B
M 50-2/4H ST3B

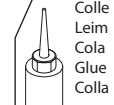
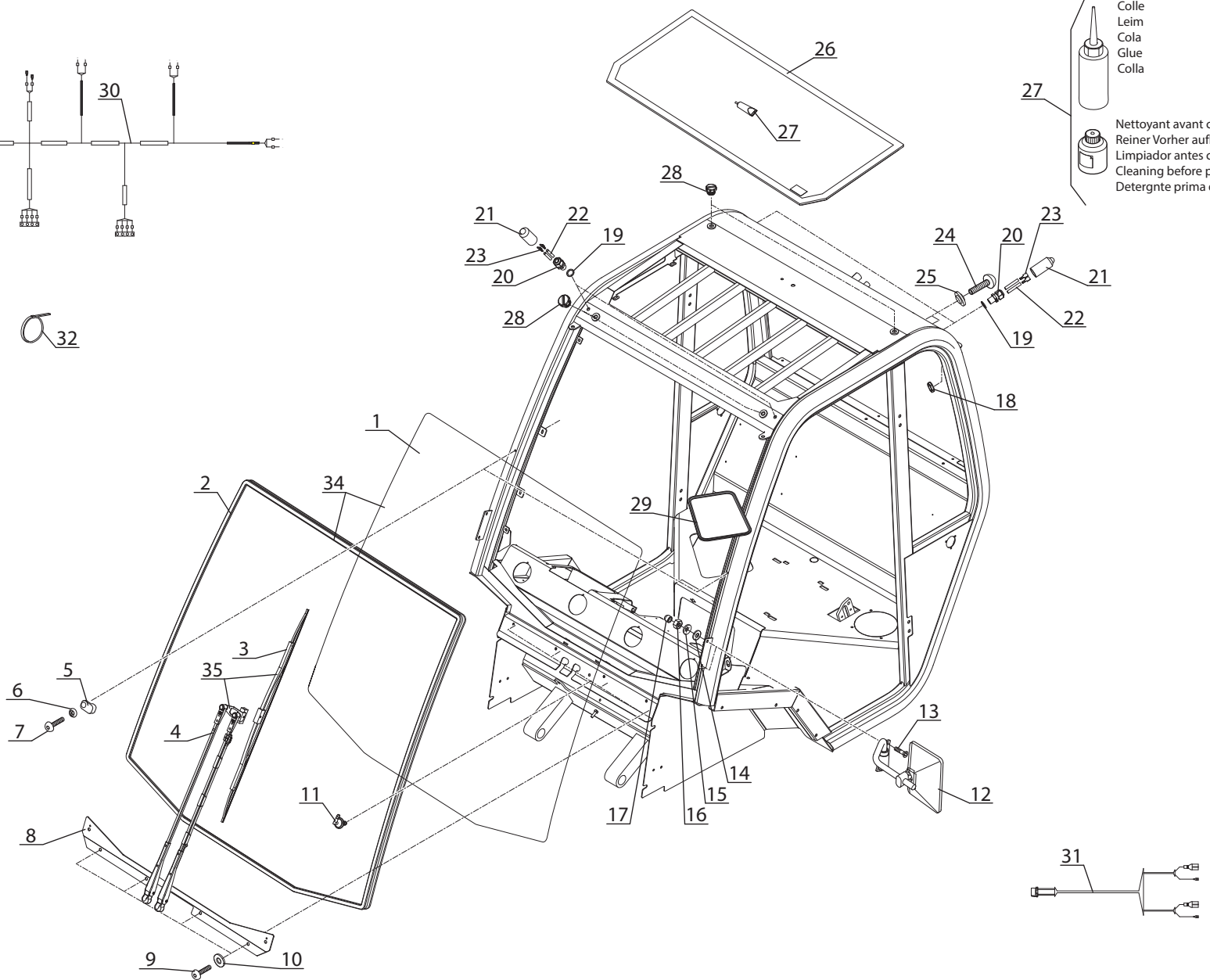
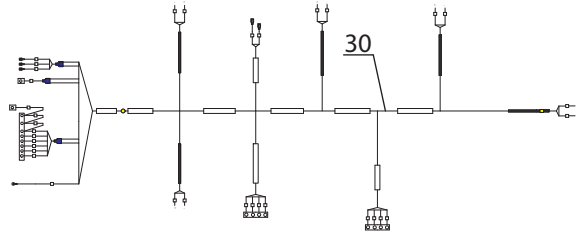

Colle
Leim
Cola
Glue
Colla



Nettoyant avant collage
Reiner Vorher aufkleben
Limpiador antes coladura
Cleaning before plasting
Detergente prima dell'incollaggio

Catalogue : 309842MOD

1	PROTEGE-CONDUCTEUR (Détails) FÜHRER SCHUTZVORRICHTUNG(Einzelteile) PROTECTOR CONDUCTOR (Detalles) DRIVER'S OVERHEAD GUARD (Details) PROTEZIONE CONDUCENTE (Dettaglio)			Qte-Menge-Cant-Qty-Q.ta										8 AB 1409									
	Rep Hinw Fig Item Rif	Numéro Teil-Nr Numero Part-Nr Part-Nr	Désignation Bezeichnung Descripcion Description Descrizione																				
				1	2	3	4	5	6	7	8	9	10	11	12	13	14	15	16	17	18	19	20
1	561086	Pare brise, nu Parabrisas, solo Vetro, nudo	- Windschutzscheibe, allein - Windscreen, stripped	1																			
2	702969	Joint profilé Junta perfilada Guarnizione	- Dichtungsstreifen - Weatherstrip	1																			
3	198290	Balai d'essuie-glace Rasqueta de limpiaparabrisas Spazzola tergicristallo	- Wischerblatt - Windshield wiper blade	1																			
4	561518	Porte balai Portaescobilla Porta spazzola	- Bürstehalter - Blade holder	1																			
5	552670	Patte de fixation Brida de fijación Flangia di fissaggio	- Befestigung auge - Fastening lug	2																			
6	706997	Rondelle plastique Arandela plástica Rondella plastica	- Plastischeibe -Plastic washer	2																			
7	205275	Vis CBHc,M 6-20-10.9-ZN5/NOIR Tornillo Vite	- Schraube -Screw	2																			
8	748135	Plaque de fixation Placa de fijación Piastra di fissaggio	- Befestigung Platte - Fastening plate	1																			
9	183396	Vis CBHc,M 6-16-ZN NOIR Tornillo Vite	- Schraube - Screw	4																			
10	741516	Rondelle Arandela Rondella	- Unterlegscheibe - Washer	4																			
11	199955	Raccord Connection	- Verschraubung - Raccordo	1																			

M

+

Catalogue : 309842MOD

Rep Hinw Fig Item Rif	Numéro Teil-Nr Numero Part-Nr Part-Nr	Désignation Bezeichnung Descripcion Description Descrizione	Qte-Menge-Cant-Qty-Q.ta										8 AB 1409									
			1- 309842MOD										11 -									
			2-										12 -									
3-										13 -												
4-										14 -												
5-										15 -												
6-										16 -												
7-										17 -												
8-										18 -												
9-										19 -												
10-										20 -												
			1	2	3	4	5	6	7	8	9	10	11	12	13	14	15	16	17	18	19	20
12	561426	Rétroviseur gauche complet - Kompletter link rückblickspiegel Retrovisor izquierdo completo - Complete L.H. rearview mirror Specchio sinistro completo	1																			
13	29441	Vis FHc,M 6-20-10.9-ZN5/C - Schraube Tornillo - Screw Vite	2																			
14	29469	Rondelle M 6 ZN - Unterlegscheibe Arandela - Washer Rondella	2																			
15	42316	Rondelle W 6 ZN - Unterlegscheibe Arandela - Washer Rondella	2																			
16	25714	Ecrou H ,M 6 ZN - Mutter Tuerca - Nut Dado	2																			
17	55404	Capuchon - Kappe Capuchón - Cap Cappuccio	2																			
18	551557	Ecrou - Mutter Tuerca - Nut Dado	3																			
19	551556	Rondelle - Unterlegscheibe Arandela - Washer Rondella	5																			
20	551555	Presse étoupe - Stopfbüchse Prensaestopas - Packing box Premistoppa	5																			
21	551558	Capuchon - Kappe Capuchón - Cap Cappuccio	5																			
22	797972	Protection - Schütz Protección - Protezione	10																			

+

M

Catalogue : 309842MOD

Rep Hinw Fig Item Rif	Numéro Teil-Nr Numero Part-Nr Part-Nr	Désignation Bezeichnung Descripcion Description Descrizione	Qte-Menge-Cant-Qty-Q.ta										8 AB 1409									
			1- 309842MOD 11 -																			
			2- 12 -																			
3- 13 -																						
4- 14 -																						
5- 15 -																						
6- 16 -																						
7- 17 -																						
8- 18 -																						
9- 19 -																						
10- 20 -																						
1	2	3	4	5	6	7	8	9	10	11	12	13	14	15	16	17	18	19	20			
23	561342	Cosse Guardacabo Capocorda	- Leitungsshuh - Cable terminal	10																		
24	205275	Vis CBHc,M6-20-10.9-ZN5/NOIR Tornillo Vite	- Schraube - Screw	2																		
25	194673	Rondelle plastique Arandela plástica Rondella plastica	- Plastischeibe - Plastic washer	2																		
26	206271	Hublot de toit Portillo de techo Vetro tettuccio	- Dachschirm - Roof viewing port	1																		
27	564618	Kit (colle+nettoyant avant collage) aufkelben) encoladura) plasting) prima dell'incollaggio)	- Kit (leim+reiniger vorher - Kit (cola + limpiador antes - Kit (glue + cleaning before - Kit (colla + detergente	1																		
28	562202	Bouchon Tapon Tappo	- Stopfen - Plug	4																		
29	171912	Joint Junta Guarnizione	- Dichtung - Seal	1																		
30	603306	Faisceau Haz Fascio	- Kabelbaum - Wiring harness	1																		
31	797973	Faisceau "Autoradio" Haz "Autorradio" Fascio "Autoradio"	- Kabelbaum "Autokino" - Wiring harn."Car radio"	1																		
32	551541	Serre-câble Terminal de cable Serracava	- Kabel klemme - Cable clamp	2																		

M

+

Catalogue : 309842MOD

Rep Hinw Fig Item Rif	Numéro Teil-Nr Numero Part-Nr Part-Nr	Désignation Bezeichnung Descripcion Description Descrizione	Qte-Menge-Cant-Qty-Q.ta										8 AB 1409									
			1	2	3	4	5	6	7	8	9	10	11	12	13	14	15	16	17	18	19	20
4		PROTEGE-CONDUCTEUR (Détails) FÜHRER SCHUTZVORRICHTUNG(Einzelteile) PROTECTOR CONDUCTOR (Detalles) DRIVER'S OVERHEAD GUARD (Details) PROTEZIONE CONDUCENTE (Dettaglio)	1- 309842MOD 11 - 2- 12 - 3- 13 - 4- 14 - 5- 15 - 6- 16 - 7- 17 - 8- 18 - 9- 19 - 10- 20 -																			
33	561531	Clip - Klammer Clip - Clip Fermagilo	2																			
34	561515	Pare brise+Joint prof. - Windschutzscheibe + Dichtungsstreifen - Parabrisas + Junta perfila lada - Windscreen + Weatherstrip Vetro + Guarnizióne	1																			
35	797971	Balai d'essuie-glace - Scheibenwisher bürste Rasqueta de limpiaparabrisas - Windshield wiper blade Spazzola tergicristallo	1																			

M

8 AB 1410

POUR TYPE DE CABINE
FÜR KABINE TYPEN
PARA TIPO DE CABINA
FOR CAB TYPE
PER TIPO DI CABINA
□ 309 842

PROTEGE-CONDUCTEUR (Détails)
FÜHRER SCHUTZVORRICHTUNG (Einzelteile)
PROTECTOR CONDUCTOR (Detailles)
DRIVER'S OVERHEAD GUARD (Details)
PROTEZIONE CONDUCENTE (Dettaglio)

M 26-2/4 ST3B M 26-2/4H ST3B
M 30-2/4 ST3B M 30-2/4H ST3B
M 40-2/4 ST3B M 40-2/4H ST3B
M 50-2/4 ST3B M 50-2/4H ST3B

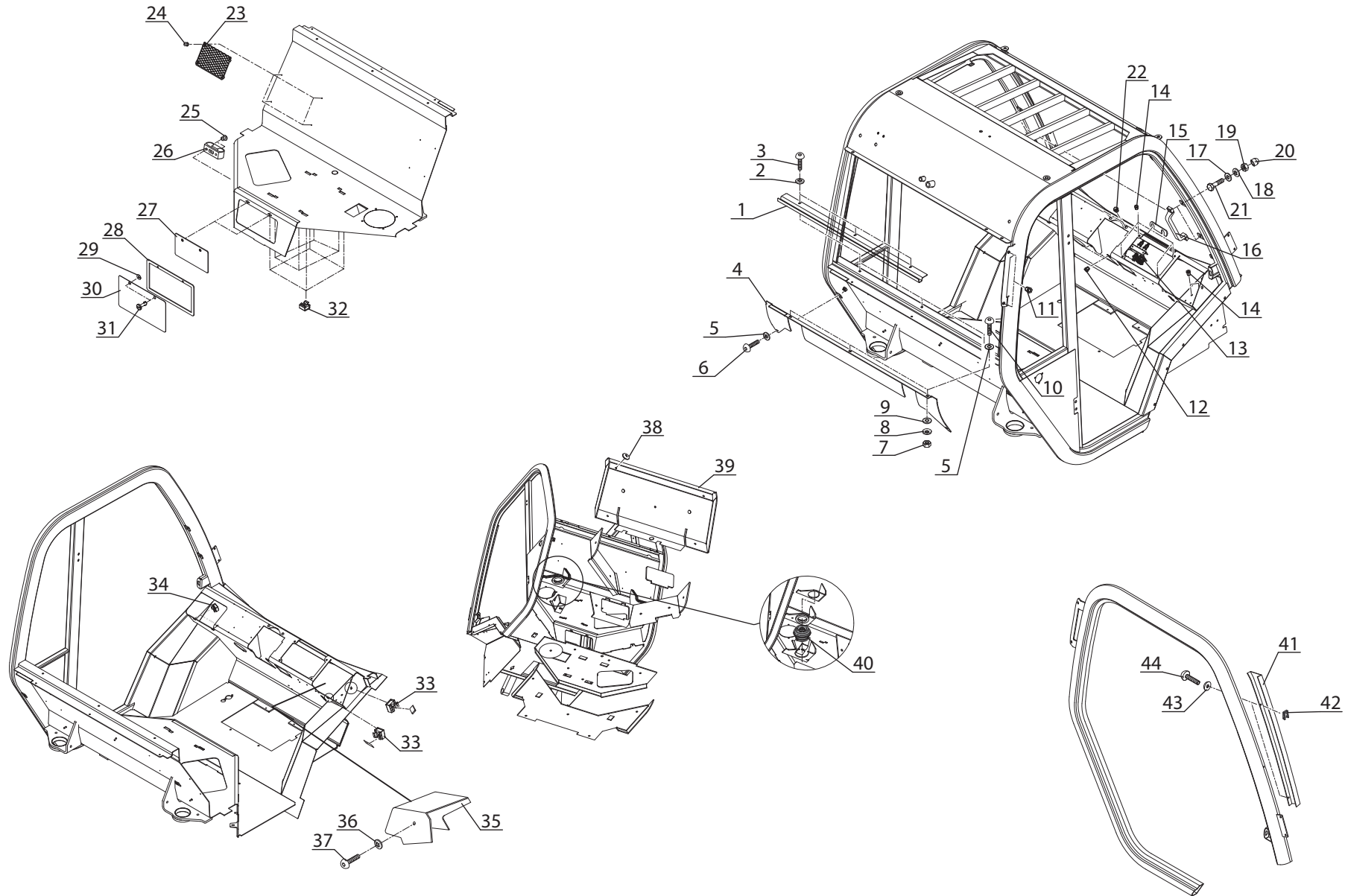

Catalogue : 309842MOD

Rep Hinw Fig Item Rif	Numéro Teil-Nr Numero Part-Nr Part-Nr	Désignation Bezeichnung Descripcion Description Descrizione	Qte-Menge-Cant-Qty-Q.ta										8 AB 1410									
			1	2	3	4	5	6	7	8	9	10	11	12	13	14	15	16	17	18	19	20
1		PROTEGE-CONDUCTEUR (Détails) FÜHRER SCHUTZVORRICHTUNG(Einzelteile) PROTECTOR CONDUCTOR (Detalles) DRIVER'S OVERHEAD GUARD (Details) PROTEZIONE CONDUCENTE (Dettaglio)	1- 309842MOD	11 -																		
			2-	12 -																		
			3-	13 -																		
			4-	14 -																		
			5-	15 -																		
			6-	16 -																		
			7-	17 -																		
			8-	18 -																		
			9-	19 -																		
			10-	20 -																		
1	797974	Tôle Chapa Lamiera	- Blech - Sheat	1																		
2	706997	Rondelle plastique Arandela plástica Rondella plastica	- Plastischeibe - Plastic washer	3																		
3	205275	Vis CBHc,M 6-20-10.9-ZN5/NOIR Tornillo Vite	- Schraube - Screw	3																		
4	797975	Tôle Chapa Lamiera	- Blech - Sheat	1																		
5	741516	Rondelle Arandela Rondella	- Unterlegscheibe - Washer	5																		
6	183396	Vis CBHc,M6-16-ZN NOIR Tornillo Vite	- Schraube - Screw	2																		
7	25714	Ecrou H ,M 6 ZN Tuerca Dado	- Mutter - Nut	3																		
8	42316	Rondelle W 6 ZN Arandela Rondella	- Unterlegscheibe - Washer	3																		
9	29469	Rondelle M 6 ZN Arandela Rondella	- Unterlegscheibe - Washer	3																		
10	183396	Vis CBHc,M6-16-ZN NOIR Tornillo Vite	- Schraube - Screw	3																		
11	563864	Insert de 8 Pion Inserto	- Stuck - Insert	2																		

M

+

Catalogue : 309842MOD

Rep Hinw Fig Item Rif	Numéro Teil-Nr Numero Part-Nr Part-Nr	Désignation Bezeichnung Descripcion Description Descrizione	Qte-Menge-Cant-Qty-Q.ta										8 AB 1410									
			1- 309842MOD										11 -									
			2-										12 -									
3-										13 -												
4-										14 -												
5-										15 -												
6-										16 -												
7-										17 -												
8-										18 -												
9-										19 -												
10-										20 -												
1	2	3	4	5	6	7	8	9	10	11	12	13	14	15	16	17	18	19	20			
2																						
12	563864	Insert de 8 Pion Inserto	- Stuck - Insert	2																		
13	552672	Moteur d'essuie-glace Motor de limpiaparabrisas Motorino tergiacristallo	- Scheibenwischer motor - Windshield-wiper motor	1																		
14	601458	Insert Pion Inserto	- Stuck - Insert	6																		
15	603304	Cale Cala Spessore	- Keil -Wedge	1																		
16	195535	Poignée Agarrador Maniglia	- Handgriff - Handle	2																		
17	29469	Rondelle M 6 ZN Arandela Rondella	- Unterlegscheibe - Washer	4																		
18	42316	Rondelle W 6 ZN Arandela Rondella	- Unterlegscheibe - Washer	4																		
19	25714	Ecrou H ,M 6 ZN Tuerca Dado	- Mutter - Nut	4																		
20	55404	Capuchon Capuchón Cappuccio	- Kappe - Cap	4																		
21	744897	Vis H,M 6-20-8.8-ZN5/C Tornillo Vite	- Schraube - Screw	4																		
22	563864	Insert de 8 Pion	- Stuck - Insert	2																		

M

+

Catalogue : 309842MOD

Rep Hinw Fig Item Rif	Numéro Teil-Nr Numero Part-Nr Part-Nr	Désignation Bezeichnung Descripcion Description Descrizione	Qte-Menge-Cant-Qty-Q.ta										8 AB 1410									
			1- 309842MOD 11 -																			
			2- 12 -																			
3- 13 -																						
4- 14 -																						
5- 15 -																						
6- 16 -																						
7- 17 -																						
8- 18 -																						
9- 19 -																						
10- 20 -																						
1	2	3	4	5	6	7	8	9	10	11	12	13	14	15	16	17	18	19	20			
3		PROTEGE-CONDUCTEUR (Détails) FÜHRER SCHUTZVORRICHTUNG(Einzelteile) PROTECTOR CONDUCTOR (Detalles) DRIVER'S OVERHEAD GUARD (Details) PROTEZIONE CONDUCENTE (Dettaglio)																				
23	561110	Filet Redecilla Filétto	- Netz für dokumet - Net	1																		
24	54568	Rivet Remache Rivetto	- Niete - Rivet	4																		
25	174677	Rivet Remache Rivetto	- Niete - Rivet	4																		
26	197468	Cage de verrouillage Caja de cierre Gabbia di blocco	- Veriegeingehäuse - Locking casing	2																		
27	561545	Trappe de visite Puerta de inspección Trappola di visita	- Kontrolle klappe - Sludge door	1																		
28	166544	Joint adhésif Junta adhesiva Guarnizióne adesivo	- Klebedichtung - Adhesive gasket	1																		
29	197469	Rondelle Arandela Rondella	- Unterlegscheibe - Washer	2																		
30	706998	Trappe Trampilla Trappola	- Fallgrube - Trapdoor	1																		
31	197471	Vis de verrouillage Tornillo de bloqueo Vite di blocco	- Veriegeinschraube - Locking screw	2																		
32	551882	Ecrou Tuerca Dado	- Mutter - Nut	8																		
33	551880	Ecrou Tuerca Dado	- Mutter - Nut	2																		

M

+

Catalogue : 309842MOD

4	PROTEGE-CONDUCTEUR (Détails) FÜHRER SCHUTZVORRICHTUNG(Einzelteile) PROTECTOR CONDUCTOR (Detalles) DRIVER'S OVERHEAD GUARD (Details) PROTEZIONE CONDUCENTE (Dettaglio)			Qte-Menge-Cant-Qty-Q.ta										8 AB 1410											
				1-	309842MOD										11 -										
				2-											12 -										
			3-											13 -											
			4-											14 -											
			5-											15 -											
			6-											16 -											
			7-											17 -											
			8-											18 -											
			9-											19 -											
			10-											20 -											
Rep Hinw Fig Item Rif	Número Teil-Nr Numero Part-Nr Part-Nr	Désignation Bezeichnung Descripcion Description Descrizione																							
1	2	3	4	5	6	7	8	9	10	11	12	13	14	15	16	17	18	19	20						
34	551880	Ecrou Tuerca Dado	- Mutter - Nut	2																					
35	561544	Plaque de fermeture Placa de cierre Piastra di chiusura	- Schlussplatte - Fastening plate	1																					
36	194673	Rondelle plastique Arandela plástica Rondella plastica	- Plastischeibe - Plastic washer	2																					
37	183396	Vis CBHc,M 6-16-ZN NOIR Tornillo Vite	- Schraube - Screw	2																					
38	748137	Clip Clip Fermaglio	- Klammer - Clip	23																					
39	748138	Insonorisant Insonorizador Ammortizzatore	- Schalldämpfungmoos - Sound proofing foam	1																					
40	601457	Silentbloc Amortiguador Tasselo	- Dampfer - Shock absorber	2																					
41	561528	Gouttière Viertheaguas Grondaia	- Dachrinne - Drain trough	1																					
42	551882	Ecrou Tuerca Dado	- Mutter - Nut	2																					
43	706997	Rondelle plastique Arandela plástica Rondella plastica	- Plastischeibe - Plastic washer	2																					
44	199976	Vis CBHc,M5-20-ZNNOIR Tornillo Vite	- Schraube - Screw	2																					

M

8 AB 1411

POUR TYPE DE CABINE
FÜR KABINETYPEN
PARA TIPO DE CABINA
FOR CAB TYPE
PER TIPO DI CABINA
□ 309 842

PROTEGE-CONDUCTEUR (Détails)
FÜHRER SCHUTZVORRICHTUNG (Einzelteile)
PROTECTOR CONDUCTOR (Details)
DRIVER'S OVERHEAD GUARD (Details)
PROTEZIONE CONDUCENTE (Dettaglio)

M 26-2/4 ST3B M 26-2/4H ST3B
M 30-2/4 ST3B M 30-2/4H ST3B
M 40-2/4 ST3B M 40-2/4H ST3B
M 50-2/4 ST3B M 50-2/4H ST3B

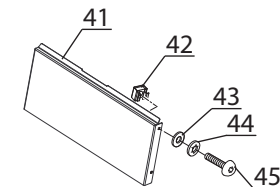
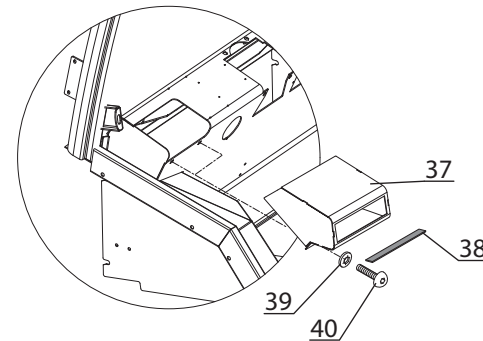
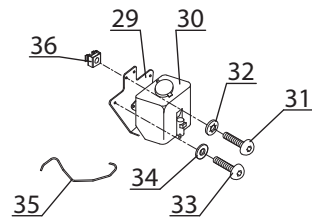
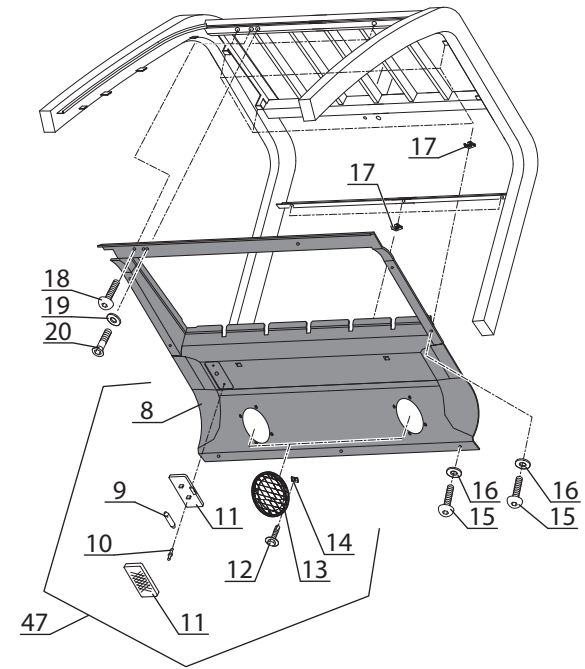
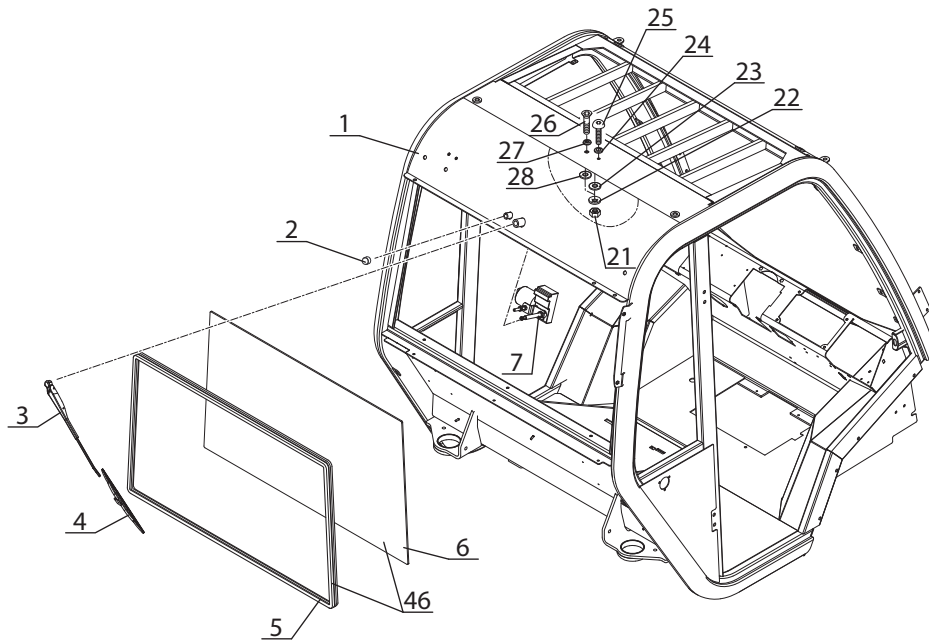

Catalogue : 309842MOD

Rep Hinw Fig Item Rif	Numéro Teil-Nr Numero Part-Nr Part-Nr	Désignation Bezeichnung Descripcion Description Descrizione	Qte-Menge-Cant-Qty-Q.ta										8 AB 1411							
			1- 309842MOD										11 -							
			2-										12 -							
3-										13 -										
4-										14 -										
5-										15 -										
6-										16 -										
7-										17 -										
8-										18 -										
9-										19 -										
10-										20 -										
1	2	3	4	5	6	7	8	9	10	11	12	13	14	15	16	17	18	19	20	
1	797976	Ossature de cabine Esqueleto de cabina Struttura cabina	- Kabine rahmenwerk - Cab frame work	1																
2	166702	Capuchon Capuchón Cappuccio	- Kappe - Cap	1																
3	797977	Bras essuie-glace Brazo limpiaparabri. Braccio tergicristallo	- Scheibenwischer ausleg - Jib windshield-wiper	1																
4	705950	Balai d'essuie-glace Rasqueta de limpiaparabrisas Spazzola tergicristallo	- Scheibenwisher bürste - Windshield wiper blade	1																
5	702963	Joint profilé Junta perfilada Guarnizione	- Dichtungsstreifen - Weatherstrip	1																
6	561087	Glace arrière, nue Cristal trasero, solo Vetro posteriore, nudo	- Hinter fensterglas,allein - Rear window glass, stripped	1																
7	552760	Moteur d'essuie-glace Motor de limpiaparabrisas Motorino tergicristallo	- Scheibenwischer motor - Windshield-wiper motor	1																
8	895160	Habillage de toit Guarnición de techo Rivestimento tetto	- Dach futter - Roof fittings	1																
9	61799	Ampoule navette Bombilla Lampadina	- Birne - Bulb	1																
10	54568	Rivet Remache Rivetto	- Niete - Rivet	2																

M

+

Catalogue : 309842MOD

Rep Hinw Fig Item Rif	Numéro Teil-Nr Numero Part-Nr Part-Nr	Désignation Bezeichnung Descripcion Description Descrizione	Qte-Menge-Cant-Qty-Q.ta										8 AB 1411									
			1- 309842MOD										11 -									
			2-										12 -									
3-										13 -												
4-										14 -												
5-										15 -												
6-										16 -												
7-										17 -												
8-										18 -												
9-										19 -												
10-										20 -												
1	2	3	4	5	6	7	8	9	10	11	12	13	14	15	16	17	18	19	20			
11	54564	Plafonnier Lámpara de techo Plafoniera	- Deckenleuchte - Roof lamp	1																		
12	741531	Vis tole 8x19 Tornillo Vite	- Schraube - Screw	8																		
13	746492	Grille Rejilla Griglia	- Gitter - Grid	2																		
14	702950	Ecrou Tuerca Dado	- Mutter - Nut	8																		
15	199976	Vis CBHc,M 5-20-ZN NOIR Tornillo Vite	- Schraube - Screw	7																		
16	706997	Rondelle plastique Arandela plástica Rondella plastica	- Plastischeibe -Plastic washer	7																		
17	551582	Ecrou Tuerca Dado	- Mutter - Nut	7																		
18	205275	Vis CBHc,M 6-20-10.9-ZN5/NOIR Tornillo Vite	- Schraube - Screw	2																		
19	561546	Rondelle Arandela Rondella	- Unterlegscheibe - Washer	2																		
20	600729	Vis Tornillo Vite	- Schraube - Screw	2																		
21	58528	Ecrou H ,M 8 ZN Tuerca Dado	- Mutter - Nut	2																		

M

+

Catalogue : 309842MOD

3	PROTEGE-CONDUCTEUR (Détails) FÜHRER SCHUTZVORRICHTUNG(Einzelteile) PROTECTOR CONDUCTOR (Detailles) DRIVER'S OVERHEAD GUARD (Details) PROTEZIONE CONDUCENTE (Dettaglio)			Qte-Menge-Cant-Qty-Q.ta										8 AB 1411									
	Rep Hinw Fig Item Rif	Numéro Teil-Nr Numero Part-Nr Part-Nr	Désignation Bezeichnung Descripcion Description Descrizione																				
				1	2	3	4	5	6	7	8	9	10	11	12	13	14	15	16	17	18	19	20
22	42325	Rondelle W 8 ZN Arandela Rondella	- Unterlegscheibe - Washer	2																			
23	61674	Rondelle M 8 ZN Arandela Rondella	- Unterlegscheibe - Washer	1																			
24	194661	Rondelle Arandela Rondella	- Unterlegscheibe - Washer	1																			
25	202144	Vis CBHc,M 8-20-10.9-ZN8/NOIR Tornillo Vite	- Schraube - Screw	1																			
26	42412	Vis FHc,M 8-20-10.9-ZN8/C Tornillo Vite	- Schraube - Screw	1																			
27	551560	Rondelle Arandela Rondella	- Unterlegscheibe - Washer	1																			
28	562051	Rondelle Arandela Rondella	- Unterlegscheibe - Washer	1																			
29	702971	Support Soporte Supporto	- Träger - Bracket	1																			
30	190776	Réservoir lave-glace Depósito lavaparabrisas Serbatoio di lavavetro	- Scheibenwaser behälter - Windshield-washer tank	1																			
31	79533	Vis CBHc,M 5- 10-10.9-ZN5/NOIR Tornillo Vite	- Schraube - Screw	2																			
32	29483	Rondelle W 5 ZN Arandela	- Unterlegscheibe - Washer - Rondella	2																			

M

+

Catalogue : 309842MOD

4	PROTEGE-CONDUCTEUR (Détails) FÜHRER SCHUTZVORRICHTUNG(Einzelteile) PROTECTOR CONDUCTOR (Detalles) DRIVER'S OVERHEAD GUARD (Details) PROTEZIONE CONDUCENTE (Dettaglio)			Qte-Menge-Cant-Qty-Q.ta										8 AB 1411										
	Rep Hinw Fig Item Rif	Número Teil-Nr Numero Part-Nr Part-Nr	Désignation Bezeichnung Descripcion Description Descrizione	1- 2- 3- 4- 5- 6- 7- 8- 9- 10-	11 - 12 - 13 - 14 - 15 - 16 - 17 - 18 - 19 - 20 -	1	2	3	4	5	6	7	8	9	10	11	12	13	14	15	16	17	18	19
33	183396	Vis CBHc,M 6- 16-ZN NOIR Tornillo Vite	- Schraube - Screw	2																				
34	194673	Rondelle plastique Arandela plástica Rondella plastica	- Plastischeibe - Plastic washer	2																				
35	797979	Tuyau lg 3.1m Tubo Tubo	- Schlauch - Hose	1																				
36	551880	Ecrou Tuerca Dado	- Mutter - Nut	2																				
37	797980	Console Consola Consolle	- Konsole - Console	1																				
38	744896	Joint profilé(Lg200) Junta perfilada Guarnizióne	- Dichtungsstreifen - Weatherstrip	1																				
39	194673	Rondelle plastique Arandela plástica Rondella plastica	- Plastischeibe -Plastic washer	2																				
40	183396	Vis CBHc,M 6-16-ZN NOIR Tornillo Vite	- Schraube - Screw	2																				
41	561525	Plaque de fermeture ava Placa de cierre del. Piastra di chiusura anteriore	- Vorn schlussplatte - Front fastening plate	1																				
42	551882	Ecrou Tuerca Dado	- Mutter - Nut	4																				
43	61674	Rondelle M 8 ZN Arandela Rondella	- Unterlegscheibe - Washer	4																				

M

+

Catalogue : 309842MOD

Rep Hinw Fig Item Rif	Numéro Teil-Nr Numero Part-Nr Part-Nr	Désignation Bezeichnung Descripcion Description Descrizione	Qte-Menge-Cant-Qty-Q.ta										8 AB 1411									
			1	2	3	4	5	6	7	8	9	10	11	12	13	14	15	16	17	18	19	20
5		PROTEGE-CONDUCTEUR (Détails) FÜHRER SCHUTZVORRICHTUNG(Einzelteile) PROTECTOR CONDUCTOR (Detalles) DRIVER'S OVERHEAD GUARD (Details) PROTEZIONE CONDUCENTE (Dettaglio)	1- 309842MOD 11 - 2- 12 - 3- 13 - 4- 14 - 5- 15 - 6- 16 - 7- 17 - 8- 18 - 9- 19 - 10- 20 -																			
44	42325	Rondelle W 8 ZN Arandela Rondella	- Unterlegscheibe - Washer										4									
45	202418	Vis CBHc,M 8-25-ZNNOIRE Tornillo Vite	- Schraube - Screw										4									
46	561520	Glace arrière+joint profilé Dichtungstreifen perfilada trip	- Hinter fensterglas + - Cristal trasero + junta - Rear win. glass + weathers- - Vetro posteriore + guarniz.										1									
47	797978	Habillage de toit Guarnición de techo Rivestimento tetto	- Dach futter - Roof fittings										1									

M

9 AA 8023

CARROSSERIE
KAROSSERIE
CARROCERIA
BODY
CARROZZERIA

M 26-2 ST3B
M 30-2 ST3B

M 26-2H ST3B
M 30-2H ST3B

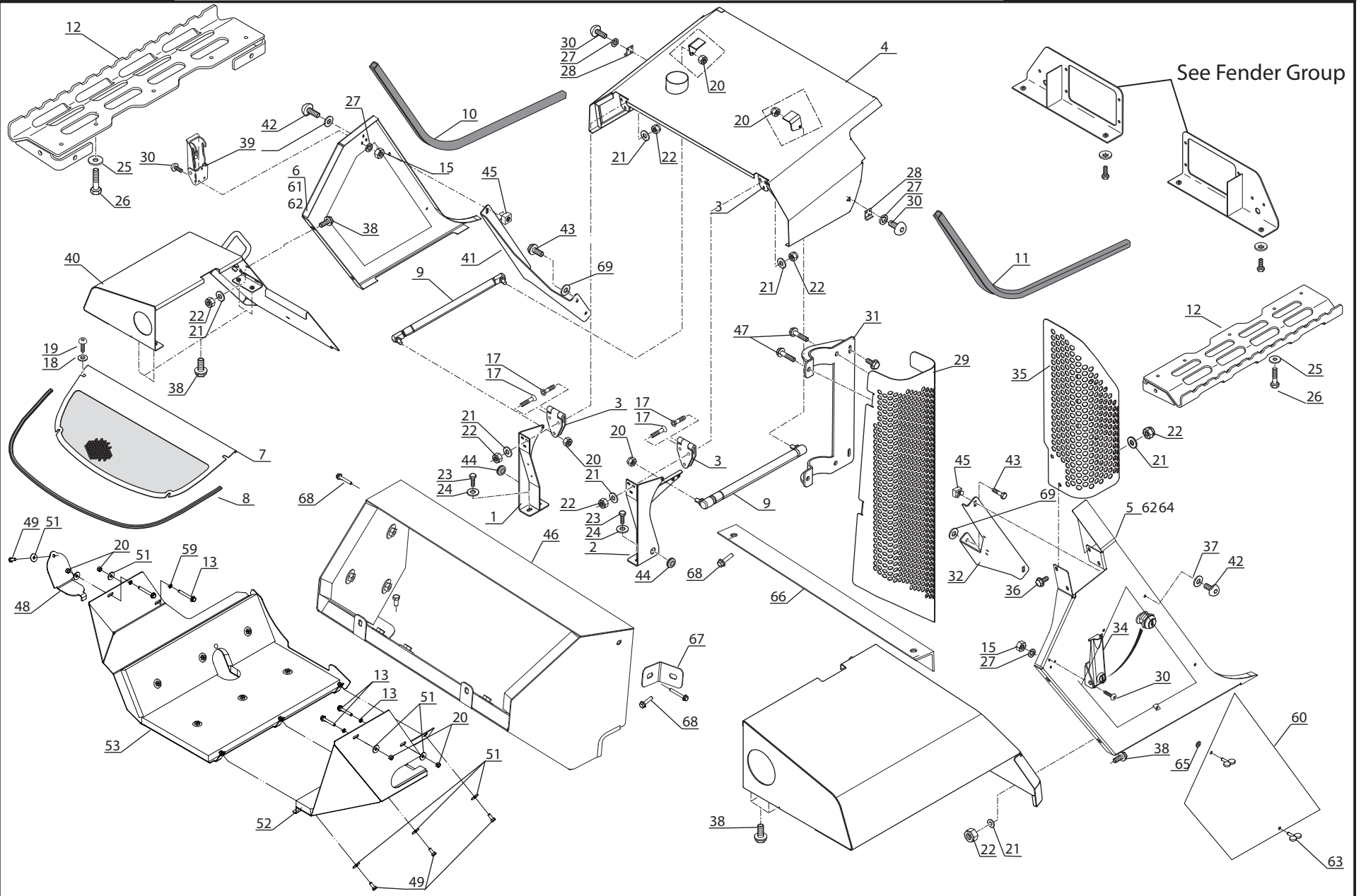

P.A.O. illus

Catalogue : 647483

Rep Hinw Fig Item Rif	Numéro Teil-Nr Numero Part-Nr Part-Nr	Désignation Bezeichnung Descripcion Description Descrizione	Qte-Menge-Cant-Qty-Q.ta										9 AA 8023									
			1	2	3	4	5	6	7	8	9	10	11	12	13	14	15	16	17	18	19	20
			1		CARROSSERIE KAROSSERIE CARROCERIA BODY CARROZZERIA																	
1	300513	Support capot gauche Soporte capot izqu. Supp. cofano sinistro	- Link haube träger - L.H. bonnet bracket	1		1						1		1								
2	300514	Support capot droit Soporte capot der. Supporto cofano destro	- Recht haube träger - R.H. bonnet bracket	1		1						1		1								
3	79570	Charnière Charnela Cerniera	- Scharnier - Hinge	2		2						2		2								
4	51300632	Capot moteur Capot motor Cofano motorino	- Motorhaube - Engine hood	1		1						1		1								
5	51300639	Volet droit Postigo derecho Farfalla destro	- Recht fensterladen - R.H. flap	1		1						1		1								
6	51300640	Volet gauche Postigo izquierdo Farfalla sinistro	- Link fensterladen - L.H. flap	1		1						1		1								
7	51300705	Grille Rejilla Grata	- Gitter - Grid	1		1						1		1								
8	302701	Joint profilé (Lg 1520) Junta perfilada Guarnizióne	- Dichtungsstreifen - Weatherstrip	1		1						1		1								
9	305149	Ressort pneumatique Resorte neumático Molla pneumatico	- Luftfeder - Air spring	2		2						2		2								
10	229598	Joint profilé (Lg 1150) Junta perfilada Guarnizióne	- Dichtungsstreifen - Weatherstrip	1		1						1		1								
11	236143	Joint profilé (Lg 1200) Junta perfilada Guarnizióne	- Dichtungsstreifen - Weatherstrip	1		1						1		1								

+

Catalogue : 647483

Rep Hinw Fig Item Rif	Numéro Teil-Nr Numero Part-Nr Part-Nr	Désignation Bezeichnung Descripcion Description Descrizione	Qte-Menge-Cant-Qty-Q.ta										9 AA 8023									
			1	2	3	4	5	6	7	8	9	10	11	12	13	14	15	16	17	18	19	20
2	CARROSSERIE KAROSSERIE CARROCCERIA BODY CARROZZERIA		1- M26- 2 ST3B	11 - M30- 2H ST3B																		
			2- M26- 4 ST3B	12 - M30- 4H ST3B																		
			3- M30- 2 ST3B	13 - M40- 2H ST3B																		
			4- M30- 4 ST3B	14 - M40- 4H ST3B																		
			5- M40- 2 ST3B	15 - M50- 2H ST3B																		
			6- M40- 4 ST3B	16 - M50- 4H ST3B																		
			7- M50- 2 ST3B	17 -																		
			8- M50- 4 ST3B	18 -																		
			9- M26- 2H ST3B	19 -																		
			10-M26- 4H ST3B	20 -																		
12	241740	Marchepied Estribo Pedana	- Trittbrett - Foot rest	2		2					2		2									
13	61323	Vis H,M 8-35-8.8-ZN8/C Tornillo Vite	- Schraube - Screw	4		4					4		4									
15	54232	Ecrou H ,M 5 ZN Tuerca Dado	- Mutter - Nut	6		6					6		6									
17	29441	Vis FHc,M 6-20-10.9-ZN5 Tornillo Vite	- Schraube - Screw	12		12					12		12									
18	198138	Rondelle L6 zinguée noire Arandela Rondella	- Unterlegscheibe - Washer	4		4					4		4									
19	205275	Vis CBHc,M 6- 20-10.9-ZN5/NOIR Tornillo Vite	- Schraube - Screw	4		4					4		4									
20	54242	Ecrou H,FR M 8 C 8 ZN..C Tuerca Dado	- Mutter - Nut	8		8					8		8									
21	459749	Rondelle L 6 ZN Arandela Rondella	- Unterlegscheibe - Washer	20		20					20		20									
22	162229	Ecrou H,FR M 6 C 8 ZN..C Tuerca Dado	- Mutter - Nut	20		20					20		20									
23	255710	Vis H,M12- 25/25-8.8-ZN8/C FR Tornillo Vite	- Schraube - Screw	4		4					4		4									
24	61678	Rondelle L 12 ZN Arandela Rondella	- Unterlegscheibe -Washer	4		4					4		4									

M

+

Catalogue : 647483

3	CARROSSERIE KAROSSERIE CARROCERIA BODY CARROZZERIA			Qte-Menge-Cant-Qty-Q.ta										9 AA 8023									
	Rep Hinw Fig Item Rif	Numéro Teil-Nr Numero Part-Nr Part-Nr	Désignation Bezeichnung Descripcion Description Descrizione	1	2	3	4	5	6	7	8	9	10	11	12	13	14	15	16	17	18	19	20
25	219852	Rondelle SP10,2x16x4ZN Arandela Rondella	- Unterlegscheibe - Washer	6		6						6		6									
26	60360	Vis H,M10-16-8.8-ZN8/C Tornillo Vite	- Schraube - Screw	6		6						6		6									
27	29483	Rondelle W 5 ZN Arandela Rondella	- Unterlegscheibe - Washer	12		12						12		12									
28	305214	Crochet Gancho Gancio	- Haken - Hook	2		2						2		2									
29	303315	Support diff. échappement Soporte difusor de escape Supporto diffusore di scarico	- Auspuff diffusor träger - Exhaust diffuser bracket	1		1						1		1									
30	184036	Vis CBHc,M 5- 16-10.9-ZN5/NOIR Tornillo Vite	- Schraube - Screw	12		12						12		12									
31	303398	Support d'échappement Soporte de escape Supporto di scarico	- Abgas träger - Exhaust bracket	1		1						1		1									
32	300395	Support latéral droit Soporte lateral der. Supporto laterale des.	- Recht seite träger - Right side bracket	1		1						1		1									
33	303658	Aile arrière droite Aleta trasera dere. Parafango post. destro	- Recht hinterkotflügel - R.H. rear fender	1		1						1		1									
34	305213	Verrou Cerrojo Catenaccio	- Riegel - Locker	1		1						1		1									
35	303411	Grille de protection Rejilla de protecc. Griglia di protezione	- Schützgitter - Protection grid	1		1						1		1									

M

+

Catalogue : 647483

4	CARROSSERIE KAROSSERIE CARROCERIA BODY CARROZZERIA			Qte-Menge-Cant-Qty-Q.ta										9 AA 8023									
	Rep Hinw Fig Item Rif	Número Teil-Nr Numero Part-Nr Part-Nr	Désignation Bezeichnung Descripcion Description Descrizione	1	2	3	4	5	6	7	8	9	10	11	12	13	14	15	16	17	18	19	20
36	273436	Vis H EMB M 6-12 8.8-ZN8/C Tornillo Vite	- Schraube - Screw	4		4					4		4										
37	189857	Rondelle M6ZN PASS.NOIRE Arandela Rondella	- Unterlegscheibe - Washer	4		4					4		4										
38	232750	Vis H EMB M6-16-8.8-ZN8/C Tornillo Vite	- Schraube - Screw	12		12					12		12										
39	303428	Verrou Cerrojo Catenaccio	- Riegel -Locker	1		1					1		1										
40	303657	Aile arrière gauche Aleta trasera izq. Parafango post. sin.	- Link hinterkotflügel - L.H. rear fender	1		1					1		1										
41	300396	Support latéral gauche Soporte lateral izq. Supporto laterale sin.	- Link seite träger - Left side bracket	1		1					1		1										
42	189172	Vis CBHc,M 6-16-10.9-ZN5/NOIR Tornillo Vite	- Schraube - Screw	4		4					4		4										
43	293804	Vis H EMB M 8-12-8.8-ZN8/C FR Tornillo Vite	- Schraube - Screw	4		4					4		4										
44	307084	Passe-fil Arandela de gaucho Passo-filo	- Gummischeibe - Cable grommet	2		2					2		2										
45	204665	Ecrou EQC M 6 D zingué Tuerca Dado	- Mutter - Nut	4		4					4		4										
46	51300698	Complete Air admission Toma de aire compl. Completo aspir. d'aria	- Komplette Lufteinlass - Complete Air Intake	1		1					1		1										

M

+

Catalogue : 647483

5	CARROSSERIE KAROSSERIE CARROCERIA BODY CARROZZERIA			Qte-Menge-Cant-Qty-Q.ta										9 AA 8023									
	Rep Hinw Fig Item Rif	Numéro Teil-Nr Numero Part-Nr Part-Nr	Désignation Bezeichnung Descripcion Description Descrizione	1	2	3	4	5	6	7	8	9	10	11	12	13	14	15	16	17	18	19	20
47	264380	Vis H EMB M 8-25 8.8-ZN8/C Tornillo Vite	- Schraube - Screw	6		6					6		6										
48	238893	Trappe de vidange Puerta de vaciado Trappola di scarico	- Klappe Ablauf - Drain door	1		1					1		1										
49	42347	Vis H,M8-20-8.8-ZN8/C Tornillo Vite	- Schraube - Screw	4		4					4		4										
51	63351	Rondelle JZC8CAD.BICH Arandela Rondella	- Unterlegscheibe - Washer	8		8					8		8										
52	308919	Carter arrière droit Carter trasero derecho Carter post. dest.	- Recht hinter kasten - R.H. rear case	1		1					1		1										
53	308887	Carter arrière gauche Carter trasero izqu. Carter post. sin.	- Link hinter kasten - L.H. rear case	1		1					1		1										
59	42325	Rondelle W 8ZN Arandela Rondella	- Unterlegscheibe - Washer	4		4					4		4										
60	51300650	Couvre ass., droite Ensamble de cubierta Derecha Coprire assemblea, diritto	- Abdeckungsanordnung, rechts - Cover Assy RH	1		1					1		1										
61	51300651	Couvre asse, gauche Cubierta de Ensamble, Izquierda Coprire il montaggio, a sinistra	- Abdeckungsanordnung, links - Cover Assy LH	1		1					1		1										
62	51300751	Adhésif mousse Cinta de espuma Nastro di schiuma	- Klebeband - Foam Tape	140		140					140		140										

+

Catalogue : 647483

6	CARROSSERIE KAROSSERIE CARROCERIA BODY CARROZZERIA			Qte-Menge-Cant-Qty-Q.ta										9 AA 8023									
	Rep Hinw Fig Item Rif	Numéro Teil-Nr Numero Part-Nr Part-Nr	Désignation Bezeichnung Descripcion Description Descrizione	1	2	3	4	5	6	7	8	9	10	11	12	13	14	15	16	17	18	19	20
63	51300647	Fermeture Sujetador Fermaglio	- Verschluss - 1/4 turn fastener	4		4					4		4										
64	51300648	Clip Clip Fermaglio	- Klammer - Clip	4		4					4		4										
65	51300649	Rondelle Arandela Rondella	- Unterlegscheibe - Washer	4		4					4		4										
66	51300690	l'ensemble cornière Montaje de ángulo Angolo montaggio	- Angle Versammlung - Angle Assy	1		1					1		1										
67	51300692	Angle ángulo Angolo	- Angle - Angle	2		2					2		2										
68	259946	Vis Tornillo Vite	- Schraube Screw	7		7					7		7										
69	61674	Rondelle Arandela Rondella	- Unterlegscheibe - Washer	4		4					4		4										

M

9 AA 8024

CARROSSERIE
KAROSSERIE
CARROCERIA
BODY
CARROZZERIA

M 26-4 ST3B
M 30-4 ST3B

M 26-4H ST3B
M 30-4H ST3B

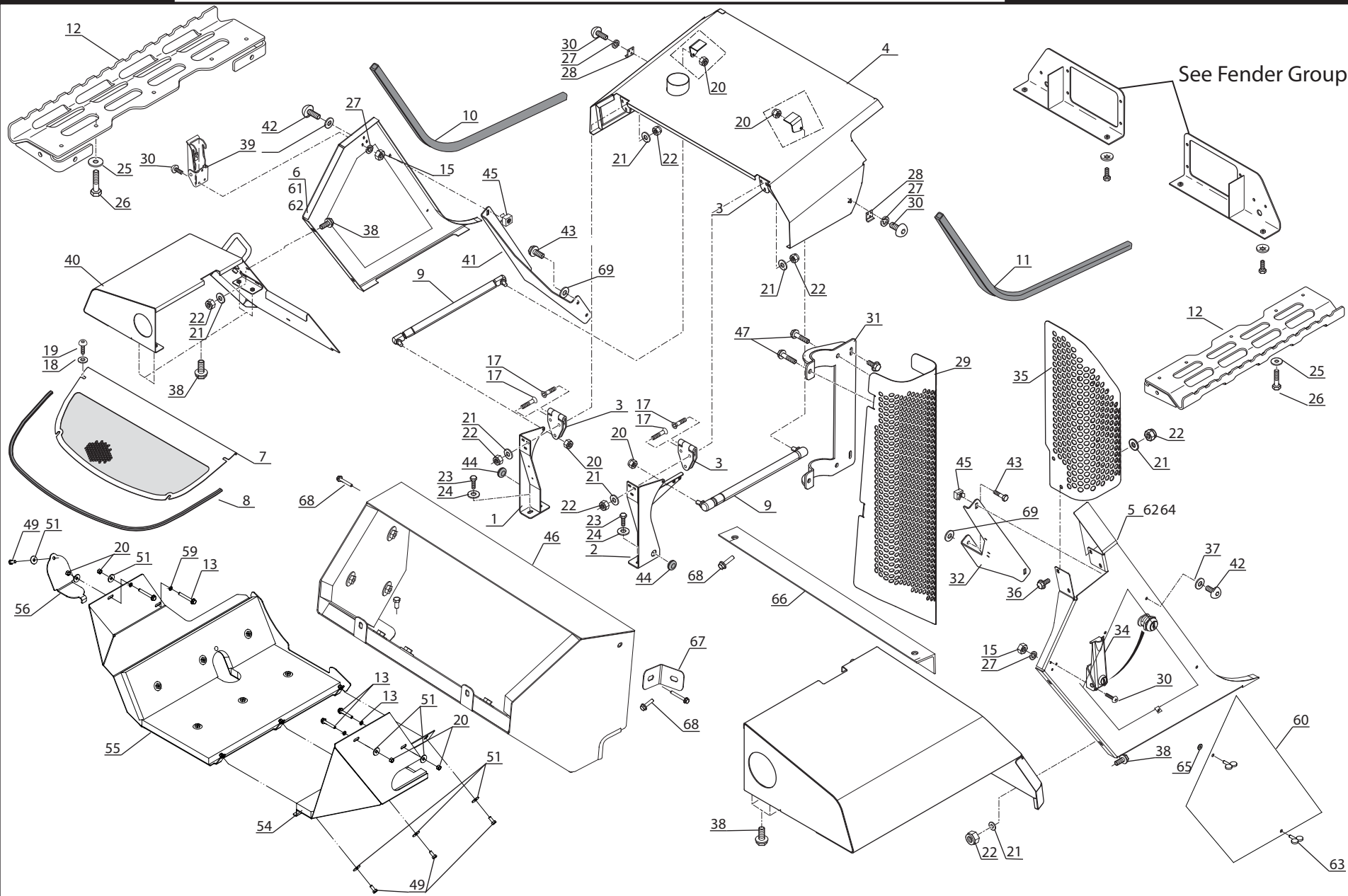

P.A.O. illus

Catalogue : 647483

1	CARROSSERIE KAROSSERIE CARROCERIA BODY CARROZZERIA			Qte-Menge-Cant-Qty-Q.ta										9 AA 8024									
	Rep Hinw Fig Item Rif	Numéro Teil-Nr Numero Part-Nr Part-Nr	Désignation Bezeichnung Descripcion Description Descrizione	1- M26- 2 ST3B 2- M26- 4 ST3B 3- M30- 2 ST3B 4- M30- 4 ST3B 5- M40- 2 ST3B 6- M40- 4 ST3B 7- M50- 2 ST3B 8- M50- 4 ST3B 9- M26- 2H ST3B 10-M26- 4H ST3B										11 - M30- 2H ST3B 12 - M30- 4H ST3B 13 - M40- 2H ST3B 14 - M40- 4H ST3B 15 - M50- 2H ST3B 16 - M50- 4H ST3B 17 - 18 - 19 - 20 -									
				1	2	3	4	5	6	7	8	9	10	11	12	13	14	15	16	17	18	19	20
1	300513	Support capot gauche Soporte capot izqu. Supp. cofano sinistro	- Link haube träger - L.H. bonnet bracket		1					1		1											
2	300514	Support capot droit Soporte capot der. Supporto cofano destro	- Recht haube träger - R.H. bonnet bracket			1				1		1											
3	79570	Charnière Charnela Cerniera	- Scharnier - Hinge			2				2		2											
4	51300632	Capot moteur Capot motor Cofano motorino	- Motorhaube - Engine hood		1		1					1		1									
5	51300639	Volet droit Postigo derecho Farfalla destro	- Recht fensterladen - R.H. flap		1		1					1		1									
6	51300640	Volet gauche Postigo izquierdo Farfalla sinistro	- Link fensterladen - L.H. flap		1		1					1		1									
7	51300705	Grille Rejilla Grata	- Gitter - Grid		1		1					1		1									
8	302701	Joint profilé (Lg 1520) Junta perfilada Guarnizióne	- Dichtungsstreifen - Weatherstrip		1		1					1		1									
9	305149	Ressort pneumatique Resorte neumático Molla pneumatico	- Luftfeder - Air spring		2		2					2		2									
10	229598	Joint profilé (Lg 1150) Junta perfilada Guarnizióne	- Dichtungsstreifen - Weatherstrip		1		1					1		1									
11	236143	Joint profilé (Lg 1200) Junta perfilada Guarnizióne	- Dichtungsstreifen - Weatherstrip		1		1					1		1									

M

+

Catalogue : 647483

Rep Hinw Fig Item Rif	Numéro Teil-Nr Numero Part-Nr Part-Nr	Désignation Bezeichnung Descripcion Description Descrizione	Qte-Menge-Cant-Qty-Q.ta										9 AA 8024									
			1	2	3	4	5	6	7	8	9	10	11	12	13	14	15	16	17	18	19	20
2	CARROSSERIE KAROSSERIE CARROCERIA BODY CARROZZERIA		1- M26- 2 ST3B	11 - M30- 2H ST3B																		
			2- M26- 4 ST3B	12 - M30- 4H ST3B																		
			3- M30- 2 ST3B	13 - M40- 2H ST3B																		
			4- M30- 4 ST3B	14 - M40- 4H ST3B																		
			5- M40- 2 ST3B	15 - M50- 2H ST3B																		
			6- M40- 4 ST3B	16 - M50- 4H ST3B																		
			7- M50- 2 ST3B	17 -																		
			8- M50- 4 ST3B	18 -																		
			9- M26- 2H ST3B	19 -																		
			10-M26- 4H ST3B	20 -																		
12	241740	Marchepied Estribo Pedana	- Trittbrett - Foot rest		2					2		2										
13	61323	Vis H,M 8-35-8.8-ZN8/C Tornillo Vite	- Schraube - Screw		4		4			4		4										
15	54232	Ecrou H ,M 5 ZN Tuerca Dado	- Mutter - Nut		6		6			6		6										
17	29441	Vis FHc,M 6-20-10.9-ZN5 Tornillo Vite	- Schraube - Screw		12		12			12		12										
18	198138	Rondelle L6 zinguée noire Arandela Rondella	- Unterlegscheibe - Washer		4		4			4		4										
19	205275	Vis CBHc,M 6- 20-10.9-ZN5/NOIR Tornillo Vite	- Schraube - Screw		4		4			4		4										
20	54242	Ecrou H,FR M 8 C 8 ZN..C Tuerca Dado	- Mutter - Nut		8		8			8		8										
21	459749	Rondelle L 6 ZN Arandela Rondella	- Unterlegscheibe - Washer		20		20			20		20										
22	162229	Ecrou H,FR M 6 C 8 ZN..C Tuerca Dado	- Mutter - Nut		20		20			20		20										
23	255710	Vis H,M12- 25/25-8.8-ZN8/C FR Tornillo Vite	- Schraube - Screw		4		4			4		4										
24	61678	Rondelle L 12 ZN Arandela Rondella	- Unterlegscheibe - Washer		4		4			4		4										

M

+

Catalogue : 647483

3	CARROSSERIE KAROSSERIE CARROCERIA BODY CARROZZERIA			Qte-Menge-Cant-Qty-Q.ta										9 AA 8024									
	Rep Hinw Fig Item Rif	Número Teil-Nr Numero Part-Nr Part-Nr	Désignation Bezeichnung Descripcion Description Descrizione	1	2	3	4	5	6	7	8	9	10	11	12	13	14	15	16	17	18	19	20
25	219852	Rondelle SP10,2x16x4ZN Arandela Rondella	- Unterlegscheibe - Washer		6		6					6		6									
26	60360	Vis H,M10-16-8.8-ZN8/C Tornillo Vite	- Schraube - Screw		6		6					6		6									
27	29483	Rondelle W 5 ZN Arandela Rondella	- Unterlegscheibe - Washer		12		12					12		12									
28	305214	Crochet Gancho Gancio	- Haken - Hook		2		2					2		2									
29	303315	Support diff. échappement Soporte difusor de escape Supporto diffusore di scarico	- Auspuff diffusor träger - Exhaust diffuser bracket		1		1					1		1									
30	184036	Vis CBHc,M 5- 16-10.9-ZN5/NOIR Tornillo Vite	- Schraube - Screw		12		12					12		12									
31	303398	Support d'échappement Soporte de escape Supporto di scarico	- Abgas träger - Exhaust bracket		1		1					1		1									
32	300395	Support latéral droit Soporte lateral der. Supporto laterale des.	- Recht seite träger - Right side bracket		1		1					1		1									
33	303658	Aile arrière droite trasera dere. Parafango post. destro	- Recht hinterkotflügel Aleta - R.H. rear fender		1		1					1		1									
34	305213	Verrou Cerrojo Catenaccio	- Riegel - Locker		1		1					1		1									
35	303411	Grille de protection Rejilla de protecc. Griglia di protezione	- Schützgitter - Protection grid		1		1					1		1									

M

+

Catalogue : 647483

4	CARROSSERIE KAROSSERIE CARROCERIA BODY CARROZZERIA			Qte-Menge-Cant-Qty-Q.ta										9 AA 8024									
	Rep Hinw Fig Item Rif	Número Teil-Nr Numero Part-Nr Part-Nr	Désignation Bezeichnung Descripcion Description Descrizione	1	2	3	4	5	6	7	8	9	10	11	12	13	14	15	16	17	18	19	20
36	273436	Vis H EMB M 6-12 8.8-ZN8/C Tornillo Vite	- Schraube - Screw		4		4					4		4									
37	189857	Rondelle M6ZN PASS.NOIRE Arandela Rondella	- Unterlegscheibe - Washer				4					4		4									
38	232750	Vis H EMB M6-16-8.8-ZN8/C Tornillo Vite	- Schraube - Screw			12		12				12		12									
39	303428	Verrou Cerrojo Catenaccio	- Riegel - Locker				1		1			1		1									
40	303657	Aile arrière gauche Aleta trasera izq. Parafango post. sin.	- Link hinterkotflügel - L.H. rear fender				1		1			1		1									
41	300396	Support latéral gauche Soporte lateral izq. Supporto laterale sin.	- Link seite träger - Left side bracket				1		1			1		1									
42	189172	Vis CBHc,M 6-16-10.9-ZN5/NOIR Tornillo Vite	- Schraube - Screw				4		4			4		4									
43	293804	Vis H EMB M 8-12-8.8-ZN8/C FR Tornillo Vite	- Schraube - Screw				4		4			4		4									
44	307084	Passe-fil Arandela de gaucho Passo-filo	- Gummischeibe - Cable grommet				2		2			2		2									
45	204665	Ecrou EQC M 6 D zingué Tuerca Dado	- Mutter - Nut				4		4			4		4									
46	51300698	Complete Air admission Toma de aire compl. Completo aspir. d'aria	- Komplette Lufteinlass - Complete Air Intake				1		1			1		1									

M

+

Catalogue : 647483

5	CARROSSERIE KAROSSERIE CARROCERIA BODY CARROZZERIA			Qte-Menge-Cant-Qty-Q.ta										9 AA 8024									
	Rep Hinw Fig Item Rif	Número Teil-Nr Numero Part-Nr Part-Nr	Désignation Bezeichnung Descripcion Description Descrizione	1	2	3	4	5	6	7	8	9	10	11	12	13	14	15	16	17	18	19	20
47	264380	Vis H EMB M 8-25 8.8-ZN8/C Tornillo Vite	- Schraube - Screw		6		6					6		6									
49	42347	Vis H,M8-20-8.8-ZN8/C Tornillo Vite	- Schraube - Screw			4		4				4		4									
51	63351	Rondelle JZC8CAD.BICH Arandela Rondella	- Unterlegscheibe - Washer			8		8				8		8									
54	309016	Carter arrière droit Carter trasero derecho Carter post. dest.	- Recht hinter kasten - R.H. rear case		1		1					1		1									
55	309017	Carter arrière gauche Carter trasero izqu. Carter post. sin.	- Link hinter kasten - L.H. rear case		1		1					1		1									
56	238835	Trappe de vidange Puerta de vaciado Trappola di scarico	- Klappe Ablauf - Drain door		1		1					1		1									
59	42325	Rondelle W 8ZN Arandela Rondella	- Unterlegscheibe - Washer			4		4				4		4									
60	51300650	Couvre ass., droite Ensamble de cubierta Dereche Coprire assemblea, diritto	- Abdeckungsanordnung, rechts - Cover Assy RH		1		1					1		1									
61	51300651	Couvre asse, gauche Cubierta de Ensamble, Izquierda Coprire il montaggio, a sinistra	- Abdeckungsanordnung, links - Cover Assy LH		1		1					1		1									
62	51300751	Adhésif mousse Cinta de espuma Nastro di schiuma	- Klebeband - Foam Tape		140		140					140		140									

M

+

Catalogue : 647483

6	CARROSSERIE KAROSSERIE CARROCERIA BODY CARROZZERIA			Qte-Menge-Cant-Qty-Q.ta										9 AA 8024									
	Rep Hinw Fig Item Rif	Numéro Teil-Nr Numero Part-Nr Part-Nr	Désignation Bezeichnung Descripcion Description Descrizione	1	2	3	4	5	6	7	8	9	10	11	12	13	14	15	16	17	18	19	20
63	51300647	Fermeture Sujetador Fermaglio	- Verschluss - 1/4 turn fastener		4		4					4		4									
64	51300648	Clip Clip Fermaglio	- Klammer - Clip		4		4					4		4									
65	51300649	Rondelle Arandela Rondella	- Unterlegscheibe - Washer		4		4					4		4									
66	51300690	l'ensemble cornière Montaje de ángulo Angolo montaggio	- Angle Versammlung - Angle Assy		1		1					1		1									
67	51300692	Angle ángulo Angolo	- Angle - Angle		2		2					2		2									
68	259946	Vis Tornillo Vite	- Schraube - Screw		7		7					7		7									
69	61674	Rondelle Arandela Rondella	- Unterlegscheibe - Washer		4		4					4		4									

M

9 AA 8025

CARROSSERIE
KAROSSERIE
CARROCERIA
BODY
CARROZZERIA

M 40-4 ST3B
M 50-4 ST3B

M 40-4H ST3B
M 50-4H ST3B

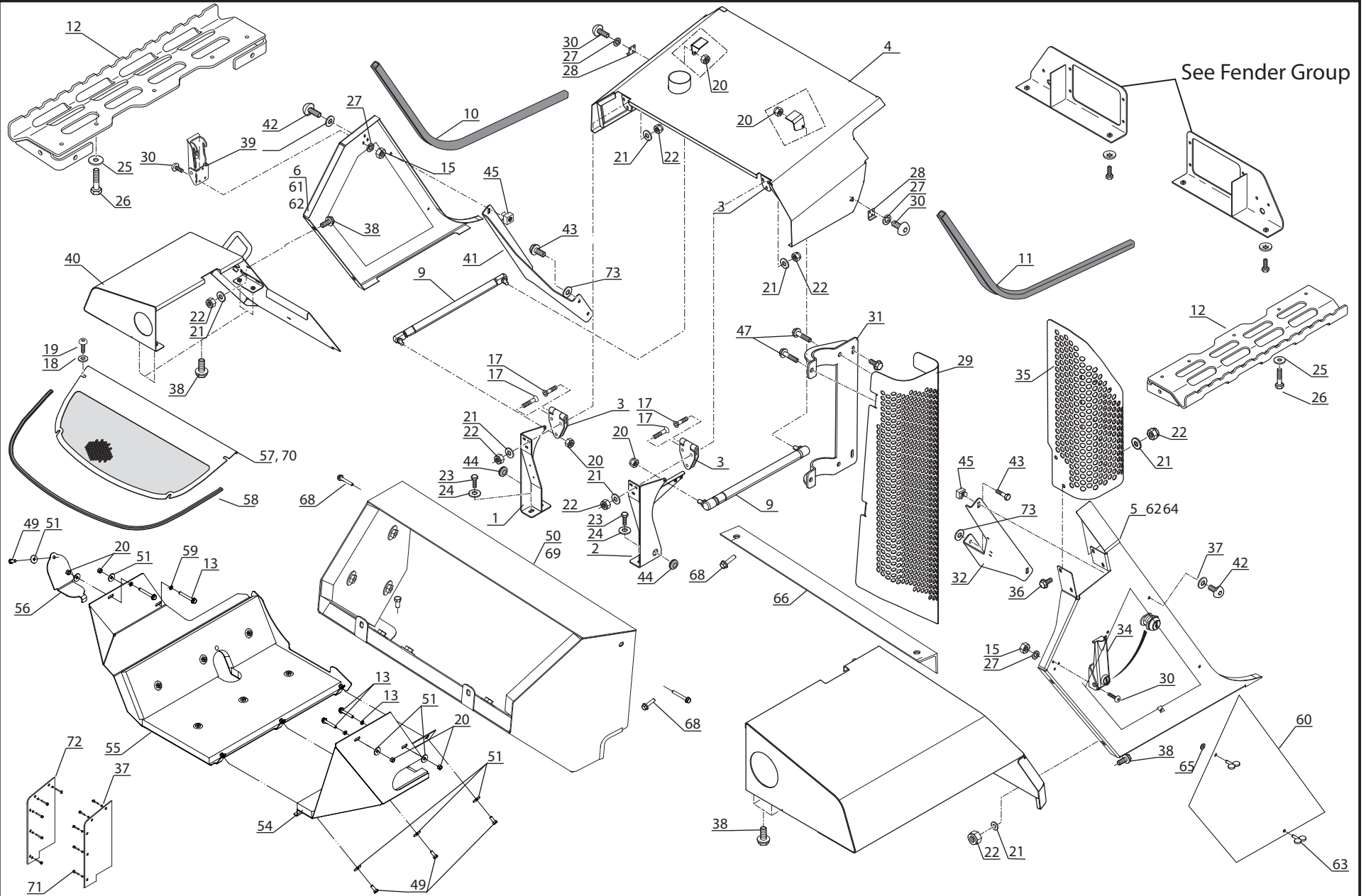

P.A.O. illus

Catalogue : 647483

Rep Hinw Fig Item Rif	Numéro Teil-Nr Numero Part-Nr Part-Nr	Désignation Bezeichnung Descripcion Description Descrizione	Qte-Menge-Cant-Qty-Q.ta										9 AA 8025									
			1	2	3	4	5	6	7	8	9	10	11	12	13	14	15	16	17	18	19	20
2	CARROSSERIE KAROSSERIE CARROCERIA BODY CARROZZERIA		1- M26- 2 ST3B	11 - M30- 2H ST3B																		
			2- M26- 4 ST3B	12 - M30- 4H ST3B																		
			3- M30- 2 ST3B	13 - M40- 2H ST3B																		
			4- M30- 4 ST3B	14 - M40- 4H ST3B																		
			5- M40- 2 ST3B	15 - M50- 2H ST3B																		
			6- M40- 4 ST3B	16 - M50- 4H ST3B																		
			7- M50- 2 ST3B	17 -																		
			8- M50- 4 ST3B	18 -																		
			9- M26- 2H ST3B	19 -																		
			10-M26- 4H ST3B	20 -																		
15	54232	Ecrou H ,M 5 ZN Tuerca Dado	- Mutter - Nut						6	6						6	6					
17	29441	Vis FHc,M 6-20-10.9-ZN5 Tornillo Vite	- Schraube - Screw						12	12					12	12						
18	198138	Rondelle L6 zinguée noire Arandela Rondella	- Unterlegscheibe - Washer						4	4					4	4						
19	205275	Vis CBHc,M 6- 20-10.9-ZN5/NOIR Tornillo Vite	- Schraube - Screw						4	4					4	4						
20	54242	Ecrou H,FR M 8 C 8 ZN..C Tuerca Dado	- Mutter - Nut						8	8					8	8						
21	459749	Rondelle L 6 ZN Arandela Rondella	- Unterlegscheibe - Washer						20	20					20	20						
22	162229	Ecrou H,FR M 6 C 8 ZN..C Tuerca Dado	- Mutter - Nut						20	20					20	20						
23	255710	Vis H,M12- 25/25-8.8-ZN8/C FR Tornillo Vite	- Schraube - Screw						4	4					4	4						
24	61678	Rondelle L 12 ZN Arandela Rondella	- Unterlegscheibe - Washer						4	4					4	4						
25	219852	Rondelle SP10,2x16x4ZN Arandela Rondella	- Unterlegscheibe - Washer						6	6					6	6						
26	60360	Vis H,M10-16-8.8-ZN8/C Tornillo Vite	- Schraube - Screw						6	6					6	6						

M

+

Catalogue : 647483

3	CARROSSERIE KAROSSERIE CARROCERIA BODY CARROZZERIA			Qte-Menge-Cant-Qty-Q.ta										9 AA 8025									
	Rep Hinw Fig Item Rif	Número Teil-Nr Numero Part-Nr Part-Nr	Désignation Bezeichnung Descripcion Description Descrizione	1	2	3	4	5	6	7	8	9	10	11	12	13	14	15	16	17	18	19	20
27	29483	Rondelle W 5 ZN Arandela Rondella	- Unterlegscheibe - Washer						12		12						12		12				
28	305214	Crochet Gancho Gancio	- Haken - Hook						2		2						2		2				
29	303315	Support diff. échappement Soporte difusor de escape Supporto diffusore di scarico	- Auspuff diffusor Träger - Exhaust diffuser bracket						1		1						1		1				
30	184036	Vis CBHc,M 5- 16-10.9-ZN5/NOIR Tornillo Vite	- Schraube - Screw						12		12						12		12				
31	303398	Support d'échappement Soporte de escape Supporto di scarico	- Abgas Träger - Exhaust bracket						1		1						1		1				
32	300395	Support latéral droit Soporte lateral der. Supporto laterale des.	- Recht seite Träger - Right side bracket						1		1						1		1				
33	303658	Aile arrière droite Aleta trasera dere. Parafango post. destro	- Recht hinterkotflügel - R.H. rear fender						1		1						1		1				
34	305213	Verrou Cerrojo Catenaccio	- Riegel - Locker						1		1						1		1				
35	303411	Grille de protection Rejilla de protecc. Griglia di protezione	- Schützgitter - Protection grid						1		1						1		1				
36	273436	Vis H EMB M 6-12 8.8-ZN8/C Tornillo Vite	- Schraube - Screw						4		4						4		4				
37	189857	Rondelle M6ZN PASS.NOIRE Arandela Rondella	- Unterlegscheibe - Washer						14		4						14		4				

M

+

Catalogue : 647483

4	CARROSSERIE KAROSSERIE CARROCERIA BODY CARROZZERIA			Qte-Menge-Cant-Qty-Q.ta										9 AA 8025									
	Rep Hinw Fig Item Rif	Numéro Teil-Nr Numero Part-Nr Part-Nr	Désignation Bezeichnung Descripcion Description Descrizione	1	2	3	4	5	6	7	8	9	10	11	12	13	14	15	16	17	18	19	20
38	232750	Vis H EMB M6-16-8.8-ZN8/C Tornillo Vite	- Schraube - Screw						12		12						12		12				
39	303428	Verrou Cerrojo Catenaccio	- Riegel - Locker						1		1						1		1				
40	303657	Aile arrière gauche Aleta trasera izq. Parafango post. sin.	- Link hinterkotflügel - L.H. rear fender						1		1						1		1				
41	300396	Support latéral gauche Soporte lateral izq. Supporto laterale sin.	- Link seite träger - Left side bracket						1		1						1		1				
42	189172	Vis CBHc,M 6-16-10.9-ZN5/NOIR Tornillo Vite	- Schraube - Screw						4		4						4		4				
43	293804	Vis H EMB M 8-12-8.8-ZN8/C FR Tornillo Vite	- Schraube - Screw						4		4						4		4				
44	307084	Passe-fil Arandela de gaucho Passo-filo	- Gummischeibe - Cable grommet						2		2						2		2				
45	204665	Ecrou EQC M 6 D zingué Tuerca Dado	- Mutter - Nut						4		4						4		4				
47	264380	Vis H EMB M 8-25 8.8-ZN8/C Tornillo Vite	- Schraube - Screw						6		6						6		6				
49	42347	Vis H,M8-20-8.8-ZN8/C Tornillo Vite	- Schraube - Screw						4		4						4		4				

M

+

Catalogue : 647483

5	CARROSSERIE KAROSSERIE CARROCERIA BODY CARROZZERIA			Qte-Menge-Cant-Qty-Q.ta										9 AA 8025									
	Rep Hinw Fig Item Rif	Numéro Teil-Nr Numero Part-Nr Part-Nr	Désignation Bezeichnung Descripcion Description Descrizione	1	2	3	4	5	6	7	8	9	10	11	12	13	14	15	16	17	18	19	20
50	51300704	Complete Air admission Toma de aire compl. Completo aspir. d'aria	- Komplette Lufteinlass - Complete Air Intake								1								1				
51	63351	Rondelle JZC8CAD.BICH Arandela Rondella	- Unterlegscheibe - Washer						8		8						8		8				
54	309016	Carter arrière droit Carter trasero derecho Carter post. dest.	- Recht hinter kasten - R.H. rear case						1		1						1		1				
55	309017	Carter arrière gauche Carter trasero izqu. Carter post. sin.	- Link hinter kasten - L.H. rear case						1		1						1		1				
56	238835	Trappe de vidange Puerta de vaciado Trappola di scarico	- Klappe Ablauf - Drain door						1		1						1		1				
57	51300708	Grille Rejilla Grata	- Gitter - Grid									1										1	
58	300476	Joint profilé (Lg 1520) Junta perfilada Guarnizione	- Dichtungsstreifen - Weatherstrip						1		1						1		1				
59	42325	Rondelle W 8ZN Arandela Rondella	- Unterlegscheibe - Washer						4		4						4		4				
60	51300650	Couvre ass., droite Ensamble de cubierta Dereche Coprire assemblea, diritto	- Abdeckungsanordnung, rechts - Cover Assy RH						1		1						1		1				
61	51300651	Couvre asse, gauche Cubierta de Ensamble, Izquierda Coprire il montaggio, a sinistra	- Abdeckungsanordnung, links - Cover Assy LH						1		1						1		1				

M

+

Catalogue : 647483

6	CARROSSERIE KAROSSERIE CARROCERIA BODY CARROZZERIA			Qte-Menge-Cant-Qty-Q.ta										9 AA 8025									
	Rep Hinw Fig Item Rif	Número Teil-Nr Numero Part-Nr Part-Nr	Désignation Bezeichnung Descripcion Description Descrizione	1	2	3	4	5	6	7	8	9	10	11	12	13	14	15	16	17	18	19	20
62	51300751	Adhésif mousse Cinta de espuma Nastro di schiuma	- Klebeband - Foam Tape						140		140						140		140				
63	51300647	Fermeture Sujetador Fermaglio	- Verschluss - 1/4 turn fastener						4		4						4		4				
64	51300648	Clip Clip Fermaglio	- Klammer - Clip						4		4						4		4				
65	51300649	Rondelle Arandela Rondella	- Unterlegscheibe - Washer						4		4						4		4				
66	51300690	l'ensemble cornière Montaje de ángulo Angolo montaggio	- Angle Versammlung - Angle Assy						1		1						1		1				
67	51300692	l'ensemble cornière Montaje de ángulo Angolo montaggio	- Angle Versammlung - Angle						2		2						2		2				
68	259946	Vis Tornillo Vite	- Schraube - Screw						7		7						7		7				
69	51400145	Complete Air admission Toma de aire compl. Completo aspir. d'aria	- Komplette Lufteinlass - Complete Air Intake						1								1						
70	51300918	Grille Rejilla Grata	- Gitter - Grid						1								1						
71	25713	Vis Tornillo Vite	- Schraube - Screw						10								10						

M

+

Catalogue : 647483

7	CARROSSERIE KAROSSERIE CARROCERIA BODY CARROZZERIA			Qte-Menge-Cant-Qty-Q.ta										9 AA 8025									
	Rep Hinw Fig Item Rif	Numéro Teil-Nr Numero Part-Nr Part-Nr	Désignation Bezeichnung Descripcion Descrizione	1	2	3	4	5	6	7	8	9	10	11	12	13	14	15	16	17	18	19	20
72	51300922	Couvre assemblage Ensamble de cubierta kansiasennelma	- Abdeckungsanordnung -Coprيره assemblea - Counterwiegth Panel - Dekselsamenstel						2								2						
73	61674	Rondelle Washer Aluslevy	- Unterlegscheibe -Rondella -Arandela -Sluitring						4		4						4		4				

M

9 AA 8026

CARROSSERIE
KAROSSERIE
CARROCERIA
BODY
CARROZZERIA

M 40-2 ST3B
M 50-2 ST3B

M 40-2H ST3B
M 50-2H ST3B

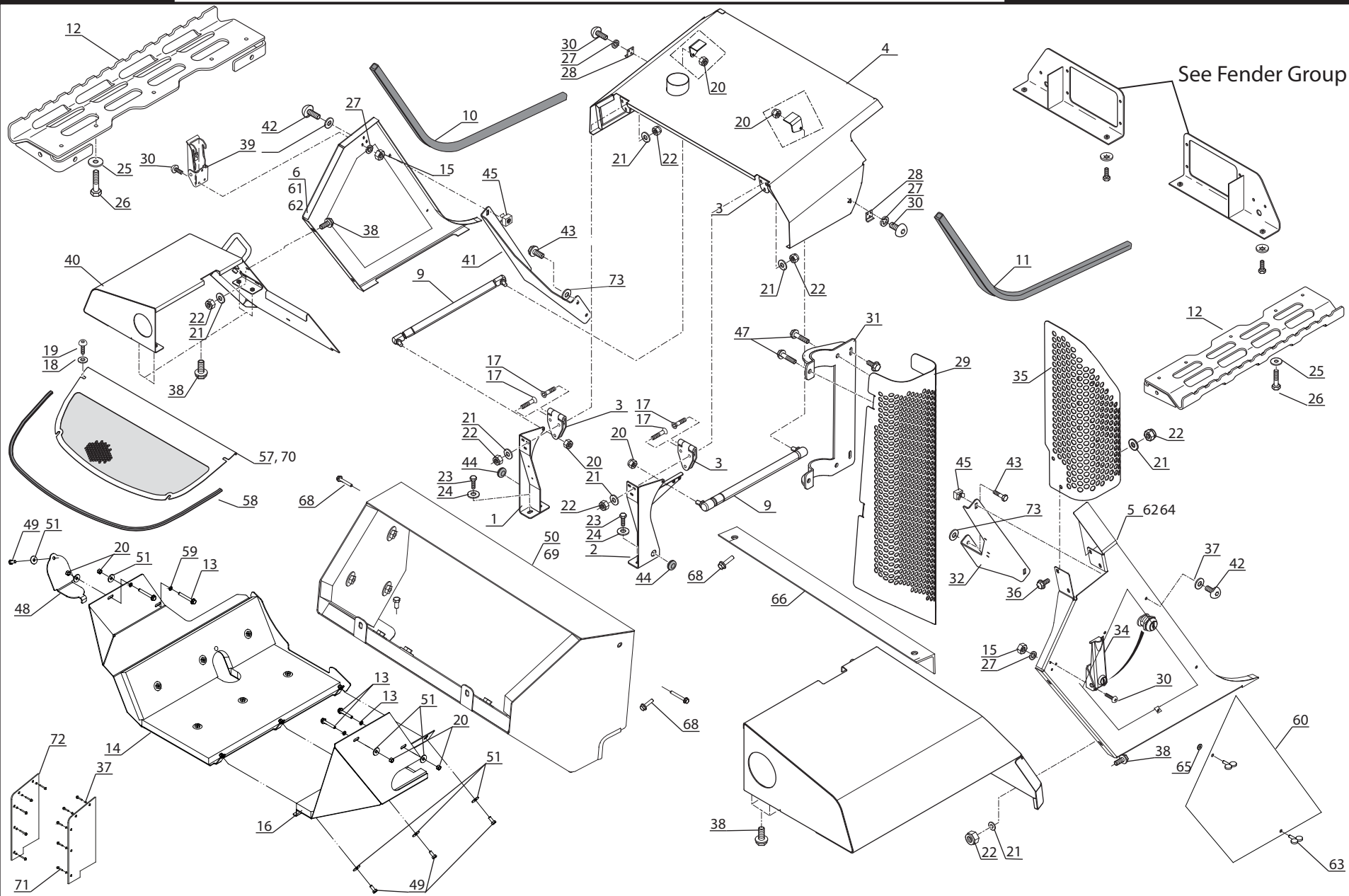

P.A.O. illus

Catalogue : 647483

2	CARROSSERIE KAROSSERIE CARROCERIA BODY CARROZZERIA		Qte-Menge-Cant-Qty-Q.ta										9 AA 8026										
	Rep Hinw Fig Item Rif	Número Teil-Nr Numero Part-Nr Part-Nr	Désignation Bezeichnung Descripcion Description Descrizione	1	2	3	4	5	6	7	8	9	10	11	12	13	14	15	16	17	18	19	20
14	51300614	Carter arrière gauche Carter trasero izqu. Carter post. sin.	- Link hinter kasten - L.H. rear case					1	1							1	1						
15	54232	Ecrou H ,M 5 ZN Tuerca Dado	- Mutter - Nut					6	6						6	6							
16	51300618	Carter arrière droit Carter trasero derecho Carter post. dest.	- Recht hinter kasten - R.H. rear case					1	1						1	1							
17	29441	Vis FHc,M 6-20-10.9-ZN5 Tornillo Vite	- Schraube - Screw					12	12						12	12							
18	198138	Rondelle L6 zinguée noire Arandela Rondella	- Unterlegscheibe - Washer					4	4						4	4							
19	205275	Vis CBHc,M 6- 20-10.9-ZN5/NOIR Tornillo Vite	- Schraube - Screw					4	4						4	4							
20	54242	Ecrou H,FR M 8 C 8 ZN..C Tuerca Dado	- Mutter - Nut					8	8						8	8							
21	459749	Rondelle L 6 ZN Arandela Rondella	- Unterlegscheibe - Washer					20	20						20	20							
22	162229	Ecrou H,FR M 6 C 8 ZN..C Tuerca Dado	- Mutter - Nut					20	20						20	20							
23	255710	Vis H,M12- 25/25-8.8-ZN8/C FR Tornillo Vite	- Schraube - Screw					4	4						4	4							
24	61678	Rondelle L 12 ZN Arandela Rondella	- Unterlegscheibe - Washer					4	4						4	4							

M

+

Catalogue : 647483

3	CARROSSERIE KAROSSERIE CARROCERIA BODY CARROZZERIA			Qte-Menge-Cant-Qty-Q.ta										9 AA 8026									
	Rep Hinw Fig Item Rif	Numéro Teil-Nr Numero Part-Nr Part-Nr	Désignation Bezeichnung Descripcion Description Descrizione	1	2	3	4	5	6	7	8	9	10	11	12	13	14	15	16	17	18	19	20
25	219852	Rondelle SP10,2x16x4ZN Arandela Rondella	- Unterlegscheibe - Washer					6	6							6	6						
26	60360	Vis H,M10-16-8.8-ZN8/C Tornillo Vite	- Schraube - Screw					6	6							6	6						
27	29483	Rondelle W 5 ZN Arandela Rondella	- Unterlegscheibe - Washer					12	12							12	12						
28	305214	Crochet Gancho Gancio	- Haken - Hook					2	2							2	2						
29	303315	Support diff. échappement Soporte difusor de escape Supporto diffusore di scarico	- Auspuff diffusor träger - Exhaust diffuser bracket					1	1							1	1						
30	184036	Vis CBHc,M 5- 16-10.9-ZN5/NOIR Tornillo Vite	- Schraube - Screw					12	12							12	12						
31	303398	Support d'échappement Soporte de escape Supporto di scarico	- Abgas träger - Exhaust bracket					1	1							1	1						
32	300395	Support latéral droit Soporte lateral der. Supporto laterale des.	- Recht seite träger - Right side bracket					1	1							1	1						
33	303658	Aile arrière droite Aleta trasera dere. Parafango post. destro	- Recht hinterkotflügel - R.H. rear fender					1	1							1	1						
34	305213	Verrou Cerrojo Catenaccio	- Riegel - Locker					1	1							1	1						
35	303411	Grille de protection Rejilla de protecc. Griglia di protezione	- Schützgitter - Protection grid					1	1							1	1						

M

+

Catalogue : 647483

4	CARROSSERIE KAROSSERIE CARROCERIA BODY CARROZZERIA		Qte-Menge-Cant-Qty-Q.ta										9 AA 8026										
	Rep Hinw Fig Item Rif	Número Teil-Nr Numero Part-Nr Part-Nr	Désignation Bezeichnung Descripcion Description Descrizione	1	2	3	4	5	6	7	8	9	10	11	12	13	14	15	16	17	18	19	20
36	273436	Vis H EMB M 6-12 8.8-ZN8/C Tornillo Vite	- Schraube - Screw					4		4						4		4					
37	189857	Rondelle M6ZN PASS.NOIRE Arandela Rondella	- Unterlegscheibe - Washer					14		4						14		4					
38	232750	Vis H EMB M6-16-8.8-ZN8/C Tornillo Vite	- Schraube - Screw					12		12						12		12					
39	303428	Verrou Cerrojo Catenaccio	- Riegel - Locker					1		1						1		1					
40	303657	Aile arrière gauche Aleta trasera izq. Parafango post. sin.	- Link hinterkotflügel - L.H. rear fender					1		1						1		1					
41	300396	Support latéral gauche Soporte lateral izq. Supporto laterale sin.	- Link seite träger - Left side bracket					1		1						1		1					
42	189172	Vis CBHc,M 6-16-10.9-ZN5/NOIR Tornillo Vite	- Schraube - Screw					4		4						4		4					
43	293804	Vis H EMB M 8-12-8.8-ZN8/C FR Tornillo Vite	- Schraube - Screw					4		4						4		4					
44	307084	Passe-fil Arandela de gaucho Passo-filo	- Gummischeibe - Cable grommet					2		2						2		2					
45	204665	Ecrou EQC M 6 D zingué Tuerca Dado	- Mutter - Nut					4		4						4		4					
47	264380	Vis H EMB M 8-25 8.8-ZN8/C Tornillo Vite	- Schraube - Screw					6		6						6		6					

M

+

Catalogue : 647483

5	CARROSSERIE KAROSSERIE CARROCERIA BODY CARROZZERIA			Qte-Menge-Cant-Qty-Q.ta										9 AA 8026									
	Rep Hinw Fig Item Rif	Numéro Teil-Nr Numero Part-Nr Part-Nr	Désignation Bezeichnung Descripcion Description Descrizione	1	2	3	4	5	6	7	8	9	10	11	12	13	14	15	16	17	18	19	20
48	238893	Trappe de vidange Puerta de vaciado Trappola di scarico	- Klappe Ablauf - Drain door							1								1					
49	42347	Vis H,M8-20-8.8-ZN8/C Tornillo Vite	- Schraube - Screw					4		4						4		4					
50	51300704	Complete Air admission Toma de aire compl. Completo aspir. d'aria	- Komplette Lufteinlass - Complete Air Intake					1		1						1		1					
51	63351	Rondelle JZC8CAD.BICH Arandela Rondella	- Unterlegscheibe - Washer					8		8						8		8					
57	51300708	Grille Rejilla Grata	- Gitter - Grid					1		1						1		1					
58	300476	Joint profilé (Lg 1520) Junta perfilada Guarnizióne	- Dichtungsstreifen - Weatherstrip					1		1						1		1					
59	42325	Rondelle W 8ZN Arandela Rondella	- Unterlegscheibe - Washer					4		4						4		4					
60	51300650	Couvre ass., droite Ensamble de cubierta Dereche Coprire assemblea, diritto	- Abdeckungsanordnung, rechts - Cover Assy RH					1		1						1		1					
61	51300651	Couvre asse, gauche Cubierta de Ensamble, Izquierda Coprire il montaggio, a sinistra	- Abdeckungsanordnung, links - Cover Assy LH					1		1						1		1					
62	51300751	Adhésif mousse Cinta de espuma Nastro di schiuma	- Klebeband - Foam Tape					140		140						140		140					

M

+

Catalogue : 647483

6	CARROSSERIE KAROSSERIE CARROCERIA BODY CARROZZERIA			Qte-Menge-Cant-Qty-Q.ta										9 AA 8026									
	Rep Hinw Fig Item Rif	Número Teil-Nr Numero Part-Nr Part-Nr	Désignation Bezeichnung Descripcion Description Descrizione	1	2	3	4	5	6	7	8	9	10	11	12	13	14	15	16	17	18	19	20
63	51300647	Fermeture Sujetador Fermaglio	- Verschluss - 1/4 turn fastener					4		4						4		4					
64	51300648	Clip Clip Fermaglio	- Klammer - Clip					4		4						4		4					
65	51300649	Rondelle Arandela Rondella	- Unterlegscheibe - Washer					4		4						4		4					
66	51300690	l'ensemble cornière Montaje de ángulo Angolo montaggio	- Angle Versammlung - Angle Assy					1		1						1		1					
67	51300692	l'ensemble cornière Angle Angolo montaggio	- Angle Versammlung - Montaje de ángulo					2		2						2		2					
68	259946	Vis Tornillo Vite	- Schraube - Screw					7		7						7		7					
69	51400145	Complete Air admission Toma de aire compl. Completo aspir. d'aria	- Komplette Lufteinlass - Complete Air Intake					1								1							
70	51300918	Grille Rejilla Grata	- Gitter - Grid					1								1							
71	25713	Vis Tornillo Vite	- Schraube - Screw					10								10							
72	51300922	Couvre assemblage Counterwiegth Panel Coprire assemblea	- Abdeckungsanordnung - Ensemble de cubierta					2								2							
73	61674	Rondelle Arandela Rondella	- Unterlegscheibe - Washer					4		4						4		4					

M

9 AB 8027

CARROSSERIE (INSONORISANT)
KAROSSERIE (SCHALLDAMPFUNGMOOS)
CARROCERIA (INSONORIZADOR)
BODY (SOUND PROOFING FOAM)
CARROZZERIA (AMMORTIZZATORE)

M 26-2 ST3B
M 30-2 ST3B

M 26-2H ST3B
M 30-2H ST3B

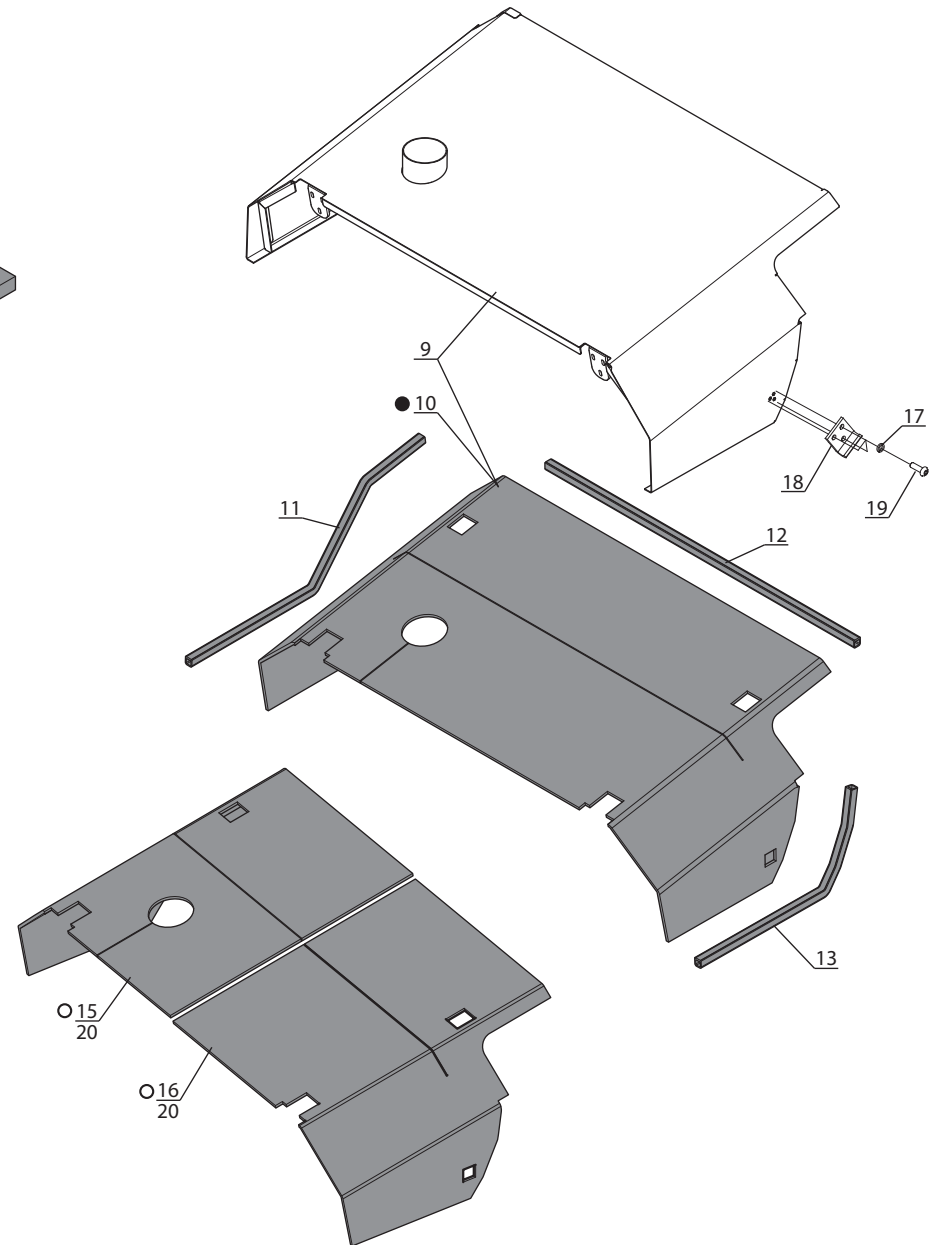
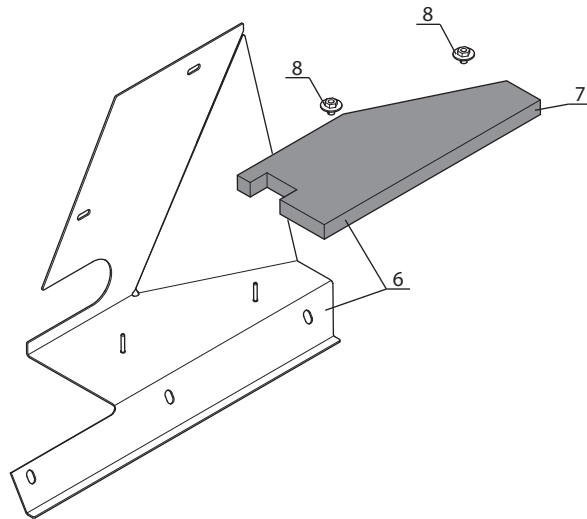
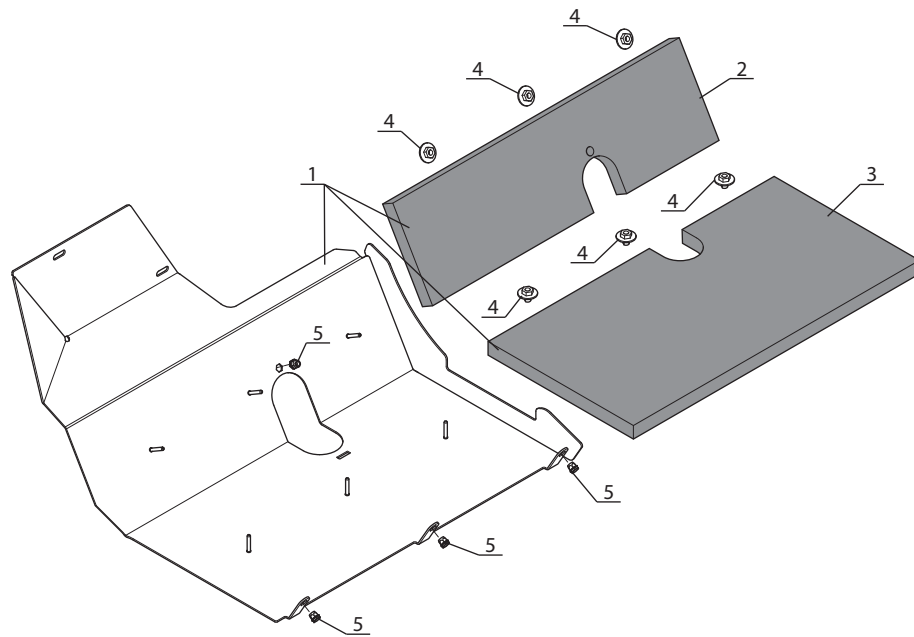

JUSQU'A LA MACHINE
BIS DER MASCHINE
HASTA LA MAQUINA
UP TO MACHINE
FINO LA MACCHINA

● → N°: 796 281

A PARTIR DE LA MACHINE
AB DER MASCHINE
A PARTIR DE LA MAQUINA
FROM MACHINE
A PARTIR DA MACCHINA

○ → N°: 796 282

Catalogue : 647483

Rep Hinw Fig Item Rif	Numéro Teil-Nr Numero Part-Nr Part-Nr	Désignation Bezeichnung Descripcion Description Descrizione	Qte-Menge-Cant-Qty-Q.ta										9 AB 8027									
			1	2	3	4	5	6	7	8	9	10	11	12	13	14	15	16	17	18	19	20
2		CARROSSERIE (INSONORISANT) KAROSSERIE (SCHALLDAMPFUNGMOOS) CARROCERIA (INSONORIZADOR) BODY (SOUND PROOFING FOAM) CARROZZERIA (AMMORTIZZATORE)																				
12	241646	Joint profilé (Lg940) Junta perfilada Guarnizióne	- Dichtungsstreifen - Weatherstrip	1		1						1		1								
13	251268	Joint profilé (Lg620) Junta perfilada Guarnizióne	- Dichtungsstreifen - Weatherstrip	1		1						1		1								
15	309976	Insonorisant gauche Insonorizador izquierdo Ammortizzatore sinistro	- Link schalldämpfungmoos - L.H. sound proofing foam	1		1						1		1								
16	309975	Insonorisant droit Insonorizador derecho Ammortizzatore destro	- Recht shalldämpfungmoos - R.H. sound proofing foam	1		1						1		1								
17	29483	Rondelle W 8 ZN Arandela Rondella	- Unterlegscheibe - Washer	12		12						12		12								
18	305214	Crochet Gancho Gancio	- Haken - Latch Plate	2		2						2		2								
19	184036	Vis Tornillo Vite	- Schraube - Screw	12		12						12		12								
20	239411	Clip Clip Fermaglio	- Klammer - Clip	18		18						18		18								

M

9 AB 8028

CARROSSERIE (INSONORISANT)
KAROSSERIE (SCHALLDAMPFUNGMOOS)
CARROCERIA (INSONORIZADOR)
BODY (SOUND PROOFING FOAM)
CARROZZERIA (AMMORTIZZATORE)

M 26-4 ST3B
M 30-4 ST3B

M 26-4H ST3B
M 30-4H ST3B

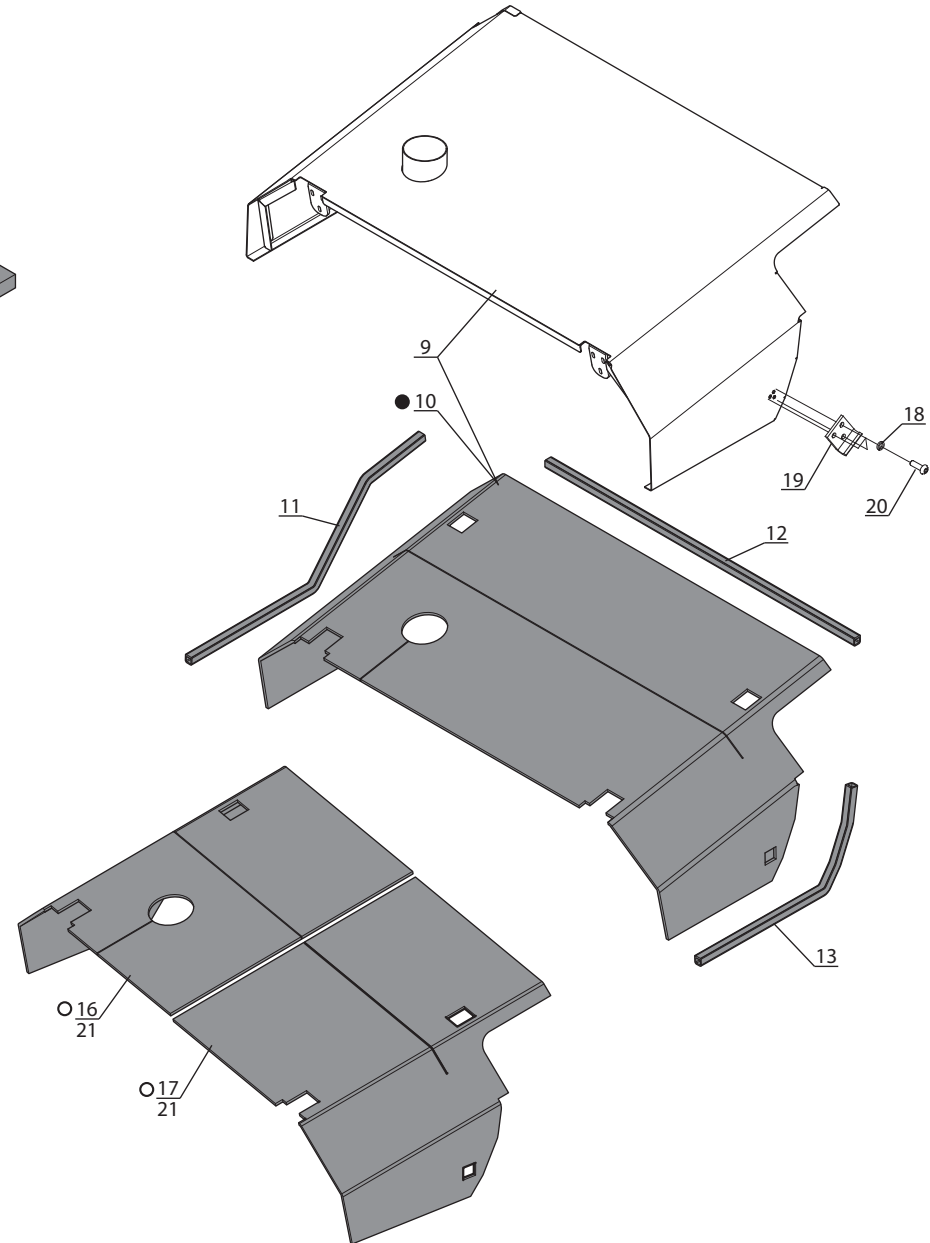
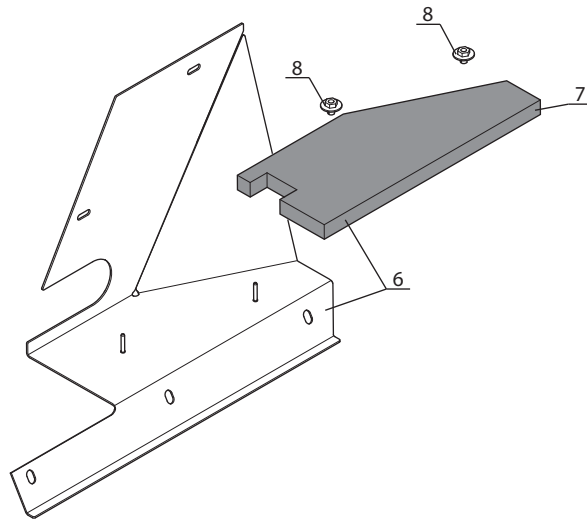
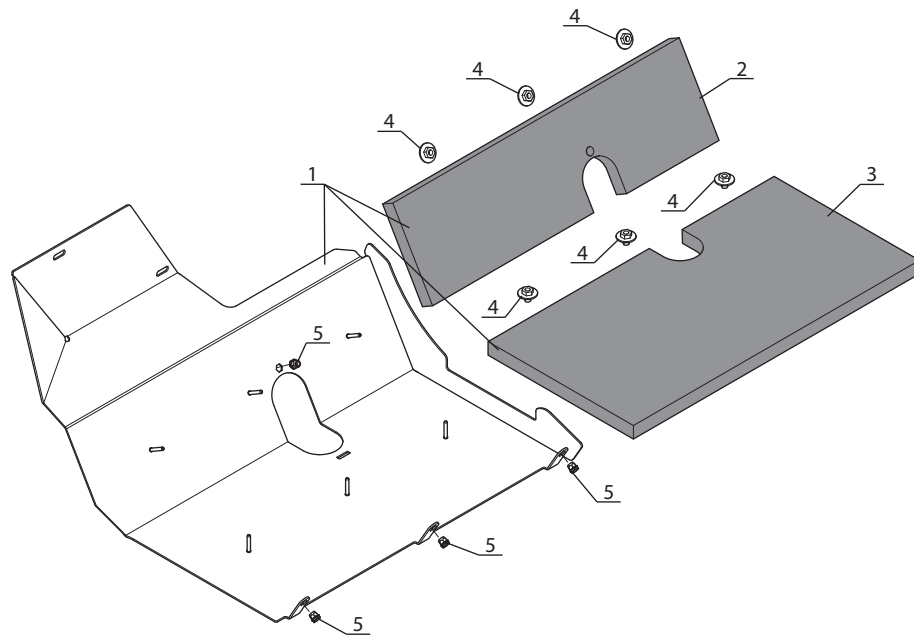

JUSQU'A LA MACHINE
BIS DER MASCHINE
HASTA LA MAQUINA
UP TO MACHINE
FINO LA MACCHINA

● → N°: 796 281

A PARTIR DE LA MACHINE
AB DER MASCHINE
A PARTIR DE LA MAQUINA
FROM MACHINE
A PARTIR DA MACCHINA

○ → N°: 796 282

Catalogue : 647483

Rep Hinw Fig Item Rif	Numéro Teil-Nr Numero Part-Nr Part-Nr	Désignation Bezeichnung Descripcion Description Descrizione	Qte-Menge-Cant-Qty-Q.ta										9 AB 8028									
			1- M26- 2 ST3B 2- M26- 4 ST3B 3- M30- 2 ST3B 4- M30- 4 ST3B 5- M40- 2 ST3B 6- M40- 4 ST3B 7- M50- 2 ST3B 8- M50- 4 ST3B 9- M26- 2H ST3B 10-M26- 4H ST3B										11 - M30- 2H ST3B 12 - M30- 4H ST3B 13 - M40- 2H ST3B 14 - M40- 4H ST3B 15 - M50- 2H ST3B 16 - M50- 4H ST3B 17 - 18 - 19 - 20 -									
			1	2	3	4	5	6	7	8	9	10	11	12	13	14	15	16	17	18	19	20
1	309017	Carter arrière gauche Carter trasero izq. Carter posterior sin. - Link hinter kasten - L.H. rear case		1		1						1		1								
2	309018	Insonorisant Insonorizador Ammortizzatore - Schalldämpfungmoos - Sound proofing foam		1		1						1		1								
3	309019	Insonorisant Insonorizador Ammortizzatore - Schalldämpfungmoos - Sound proofing foam		1		1						1		1								
4	241391	Clip Clip Fermaglio - Klammer - Clip		6		6						6		6								
5	254215	Douille M8 Casquillo Bussola - Fassung - Socket		4		4						4		4								
6	309016	Carter arrière droit Carter trasero der. Carter posterior des. - Recht hinter kasten - R.H. rear case		1		1						1		1								
7	309013	Insonorisant Insonorizador Ammortizzatore - Schalldämpfungmoos - Sound proofing foam		1		1						1		1								
8	309015	Insonorisant Insonorizador Ammortizzatore - Schalldämpfungmoos - Sound proofing foam		1		1						1		1								
9	241391	Clip Clip Fermaglio - Klammer - Clip		5		5						5		5								
10	51300632	Capot moteur Capot motor Cofano motorino - Motorhaube - Engine bonnet		1		1						1		1								
11	301489	Insonorisant Insonorizador Ammortizzatore - Schalldämpfungmoos - Sound proofing foam		1		1						1		1								

+

Catalogue : 647483

Rep Hinw Fig Item Rif	Numéro Teil-Nr Numero Part-Nr Part-Nr	Désignation Bezeichnung Descripcion Description Descrizione	Qte-Menge-Cant-Qty-Q.ta										9 AB 8028									
			1	2	3	4	5	6	7	8	9	10	11	12	13	14	15	16	17	18	19	20
2		CARROSSERIE (INSONORISANT) KAROSSERIE (SCHALLDAMPFUNGMOOS) CARROCERIA (INSONORIZADOR) BODY (SOUND PROOFING FOAM) CARROZZERIA (AMMORTIZZATORE)																				
12	300495	Joint profilé (Lg810) Junta perfilada Guarnizióne	- Dichtungsstreifen - Weatherstrip		1		1							1		1						
13	241646	Joint profilé (Lg940) Junta perfilada Guarnizióne	- Dichtungsstreifen - Weatherstrip			1		1						1		1						
14	251268	Joint profilé (Lg620) Junta perfilada Guarnizióne	- Dichtungsstreifen - Weatherstrip			1		1						1		1						
16	309976	Insonorisant gauche Insonorizador izquierdo Ammortizzatore sinistro	- Link schalldämpfungmoos - L.H. sound proofing foam		1			1						1		1						
17	309975	Insonorisant droit Insonorizador derecho Ammortizzatore destro	- Recht shalldämpfungmoos - R.H. sound proofing foam		1			1						1		1						
18	29483	Rondelle W 8 ZN Arandela Rondella	- Unterlegscheibe - Washer		12			12						12		12						
19	305214	Crochet Gancho Gancio	- Haken - Latch Plate		2			2						2		2						
20	184036	Vis Tornillo Vite	- Schraube - Screw		12			12						12		12						
21	239411	Clip Clip Fermaglio	- Klammer - Clip		18			18						18		18						

M

9 AB 8029

CARROSSERIE (INSONORISANT)
KAROSSERIE (SCHALLDAMPFUNGMOOS)
CARROCERIA (INSONORIZADOR)
BODY (SOUND PROOFING FOAM)
CARROZZERIA (AMMORTIZZATORE)

M 40-4 ST3B
M 50-4 ST3B

M 40-4H ST3B
M 50-4H ST3B

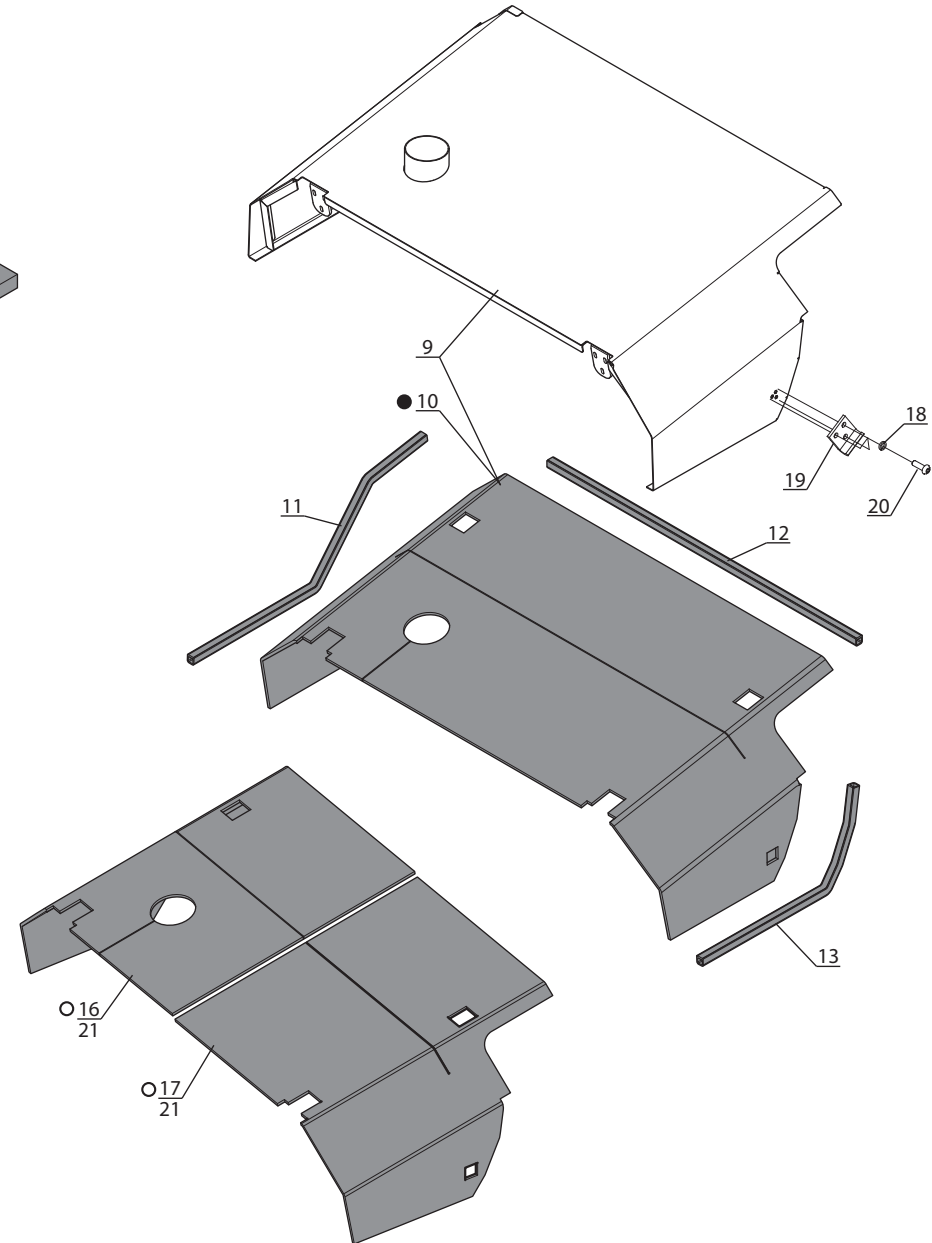
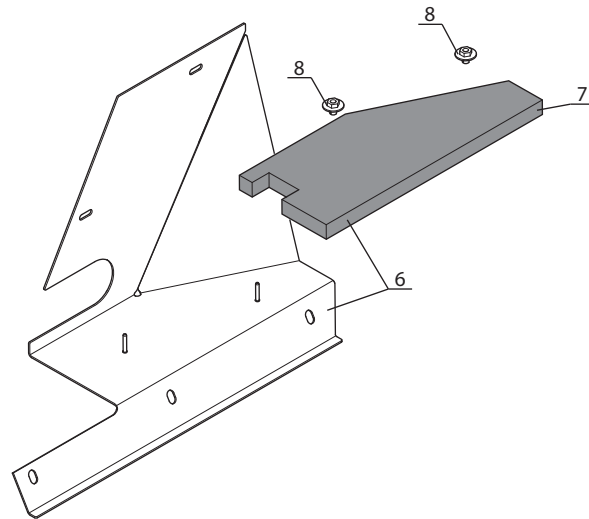
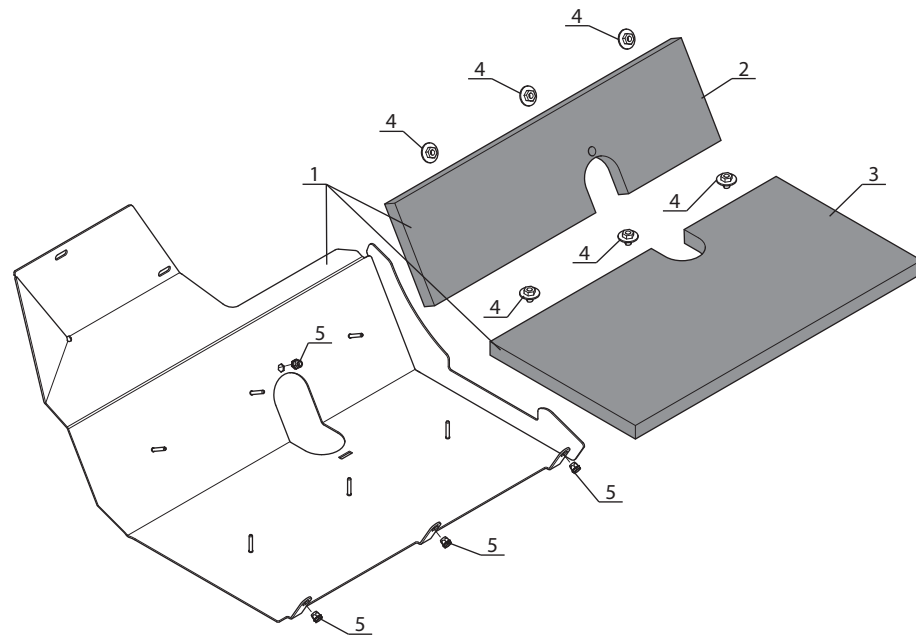

JUSQU'A LA MACHINE
BIS DER MASCHINE
HASTA LA MAQUINA
UP TO MACHINE
FINO LA MACCHINA

● → N°: 796 281

A PARTIR DE LA MACHINE
AB DER MASCHINE
A PARTIR DE LA MAQUINA
FROM MACHINE
A PARTIR DA MACCHINA

○ → N°: 796 282

Catalogue : 647483

2	CARROSSERIE (INSONORISANT) KAROSSERIE (SCHALLDAMPFUNGMOOS) CARROCERIA (INSONORIZADOR) BODY (SOUND PROOFING FOAM) CARROZZERIA (AMMORTIZZATORE)			Qte-Menge-Cant-Qty-Q.ta										9 AB 8029									
	Rep Hinw Fig Item Rif	Numéro Teil-Nr Numero Part-Nr Part-Nr	Désignation Bezeichnung Descripcion Description Descrizione	1	2	3	4	5	6	7	8	9	10	11	12	13	14	15	16	17	18	19	20
12	300495	Joint profilé (Lg810) Junta perfilada Guarnizióne	- Dichtungsstreifen - Weatherstrip						1		1						1		1				
13	241646	Joint profilé (Lg940) Junta perfilada Guarnizióne	- Dichtungsstreifen - Weatherstrip						1		1						1		1				
14	251268	Joint profilé (Lg620) Junta perfilada Guarnizióne	- Dichtungsstreifen - Weatherstrip						1		1						1		1				
16	309976	Insonorisant gauche Insonorizador izquierdo Ammortizzatore sinistro	- Link schalldämpfungmoos - L.H. sound proofing foam						1		1						1		1				
17	309975	Insonorisant droit Insonorizador derecho Ammortizzatore destro	- Recht shalldämpfungmoos - R.H. sound proofing foam						1		1						1		1				
18	29483	Rondelle W 8 ZN Arandela Rondella	- Unterlegscheibe - Washer						12		12						12		12				
19	305214	Crochet Gancho Gancio	- Haken - Latch Plate						2		2						2		2				
20	184036	Vis Tornillo Vite	- Schraube - Screw						12		12						12		12				
21	239411	Clip Clip Fermaglio	- Klammer - Clip						18		18						18		18				

M

9 AB 8030

CARROSSERIE (INSONORISANT)
KAROSSERIE (SCHALLDAMPFUNGMOOS)
CARROCERIA (INSONORIZADOR)
BODY (SOUND PROOFING FOAM)
CARROZZERIA (AMMORTIZZATORE)

M 40-2 ST3B
M 50-2 ST3B

M 40-2H ST3B
M 50-2H ST3B

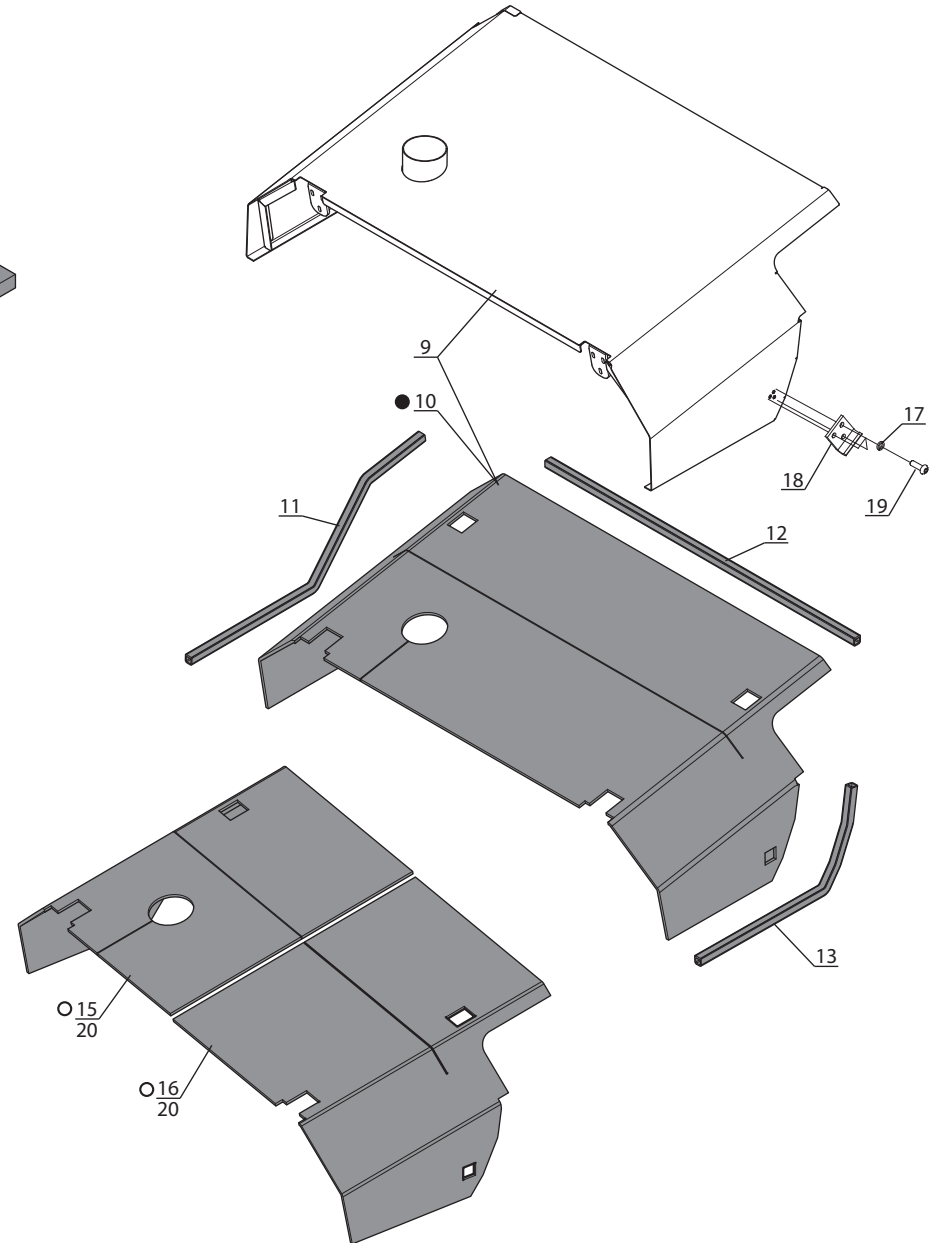
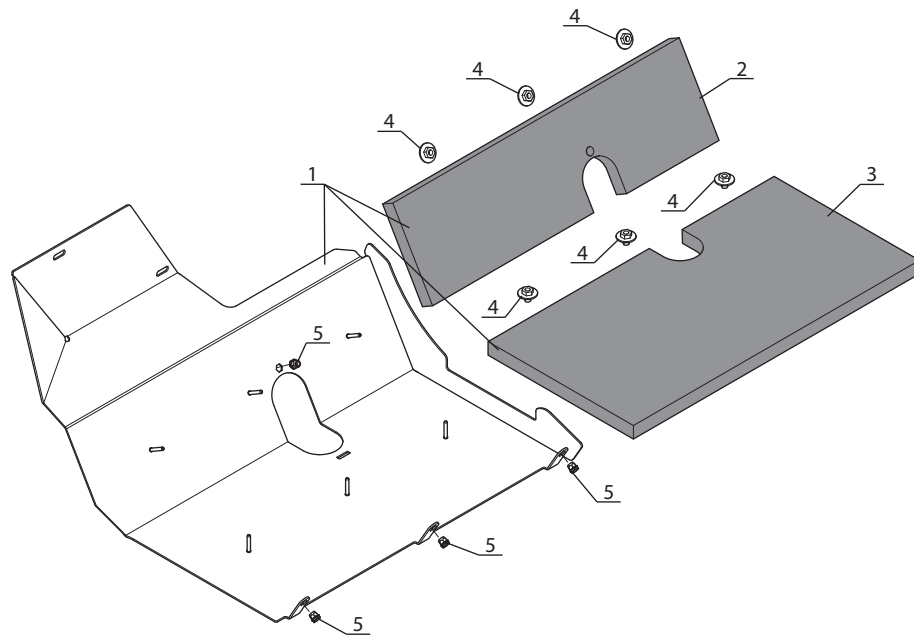

JUSQU'A LA MACHINE
BIS DER MASCHINE
HASTA LA MAQUINA
UP TO MACHINE
FINO LA MACCHINA

● → N°: 796 281

A PARTIR DE LA MACHINE
AB DER MASCHINE
A PARTIR DE LA MAQUINA
FROM MACHINE
A PARTIR DA MACCHINA

○ → N°: 796 282

Catalogue : 647483

1	CARROSSERIE (INSONORISANT) KAROSSERIE (SCHALLDAMPFUNGMOOS) CARROCERIA (INSONORIZADOR) BODY (SOUND PROOFING FOAM) CARROZZERIA (AMMORTIZZATORE)			Qte-Menge-Cant-Qty-Q.ta										9 AB 8030									
	Rep Hinw Fig Item Rif	Numéro Teil-Nr Numero Part-Nr Part-Nr	Désignation Bezeichnung Descripcion Description Descrizione	1	2	3	4	5	6	7	8	9	10	11	12	13	14	15	16	17	18	19	20
1	51300614	Carter arrière gauche Carter trasero izq. Carter posterior sin.	- Link hinter kasten - L.H. rear case					1	1							1	1						
2	308884	Insonorisant Insonorizador Ammortizzatore	- Schalldämpfungmoos - Sound proofing foam					1	1						1	1							
3	308883	Insonorisant Insonorizador Ammortizzatore	- Schalldämpfungmoos - Sound proofing foam					1	1						1	1							
4	241391	Clip Clip Fermaglio	- Klammer - Clip					6	6						6	6							
5	254215	Douille M8 Casquillo Bussola	- Fassung - Socket					4	4						4	4							
6	51300618	Carter arrière droit Carter trasero der. Carter posterior des.	- Recht hinter kasten - R.H. rear case					1	1						1	1							
7	308880	Insonorisant Insonorizador Ammortizzatore	- Schalldämpfungmoos - Sound proofing foam					1	1						1	1							
8	241391	Clip Clip Fermaglio	- Klammer - Clip					2	2						2	2							
9	51300632	Capot moteur Capot motor Cofano motorino	- Motorhaube - Engine bonnet					1	1						1	1							
10	301489	Insonorisant Insonorizador Ammortizzatore	- Schalldämpfungmoos - Sound proofing foam					1	1						1	1							
11	300495	Joint profilé (Lg810) Junta perfilada Guarnizione	- Dichtungsstreifen - Weatherstrip					1	1						1	1							

+

Catalogue : 647483

2	CARROSSERIE (INSONORISANT) KAROSSERIE (SCHALLDAMPFUNGMOOS) CARROCERIA (INSONORIZADOR) BODY (SOUND PROOFING FOAM) CARROZZERIA (AMMORTIZZATORE)			Qte-Menge-Cant-Qty-Q.ta										9 AB 8030									
	Rep Hinw Fig Item Rif	Numéro Teil-Nr Numero Part-Nr Part-Nr	Désignation Bezeichnung Descripcion Description Descrizione	1	2	3	4	5	6	7	8	9	10	11	12	13	14	15	16	17	18	19	20
12	241646	Joint profilé (Lg940) Junta perfilada Guarnizióne	- Dichtungsstreifen - Weatherstrip					1		1						1		1					
13	251268	Joint profilé (Lg620) Junta perfilada Guarnizióne	- Dichtungsstreifen - Weatherstrip					1		1						1		1					
15	309976	Insonorisant gauche Insonorizador izquierdo Ammortizzatore sinistro	- Link schalldämpfungmoos - L.H. sound proofing foam					1		1						1		1					
16	309975	Insonorisant droit Insonorizador derecho Ammortizzatore destro	- Recht shalldämpfungmoos - R.H. sound proofing foam					1		1						1		1					
17	29483	Rondelle W 8 ZN Arandela Rondella	- Unterlegscheibe - Washer					12		12						12		12					
18	305214	Crochet Gancho Gancio	- Haken - Latch Plate					2		2						2		2					
19	184036	Vis Tornillo Vite	- Schraube - Screw					12		12						12		12					
20	239411	Clip Clip Fermaglio	- Klammer - Clip					18		18						18		18					

M

Catalogue : 647483

Rep Hinw Fig Item Rif	Numéro Teil-Nr Numero Part-Nr Part-Nr	Désignation Bezeichnung Descripcion Description Descrizione	Qte-Menge-Cant-Qty-Q.ta										10 AA 8031									
			1- M26- 2 ST3B 2- M26- 4 ST3B 3- M30- 2 ST3B 4- M30- 4 ST3B 5- M40- 2 ST3B 6- M40- 4 ST3B 7- M50- 2 ST3B 8- M50- 4 ST3B 9- M26- 2H ST3B 10-M26- 4H ST3B										11 - M30- 2H ST3B 12 - M30- 4H ST3B 13 - M40- 2H ST3B 14 - M40- 4H ST3B 15 - M50- 2H ST3B 16 - M50- 4H ST3B 17 - 18 - 19 - 20 -									
			1	2	3	4	5	6	7	8	9	10	11	12	13	14	15	16	17	18	19	20
1	215535	Soufflet Fuelle Soffietto - Blasebalg - Bellows	1	1	1	1	1	1	1	1	1	1	1	1	1	1						
2	307777	Bac à huile Tanque de aceite Serbatoio olio - Ölbehälter - Oil tank	1	1	1	1	1	1	1	1	1	1	1	1	1	1						
3	167928	Raccord Union Racor Raccordo - Verschraubung - Connection	1	1	1	1	1	1	1	1	1	1	1	1	1	1						
4	77710	Rondelle HR12,5x27x2,5ZN Arandela Rondella - Unterlegscheibe - Washer	2	2	2	2	2	2	2	2	2	2	2	2	2	2						
5	77402	Crépine du circuit principal Filtro de paso de circuito principal Pigna circuito principale - Seiher hauptkreis -Principal cir. strainer	1	1	1	1	1	1	1	1	1	1	1	1	1	1						
6	77389	Jauge Galga Livello - Eichmass - Gauge	1	1	1	1	1	1	1	1	1	1	1	1	1	1						
7	63545	Vis H,M10-35-8.8-ZN8/C Tornillo Vite - Schraube - Screw	4	4	4	4	4	4	4	4	4	4	4	4	4	4						
8	63544	Vis H,M10-30-8.8-ZN8/C Tornillo Vite - Schraube - Screw	4	4	4	4	4	4	4	4	4	4	4	4	4	4						
9	304891	Verrou Cerrojo Catenaccio - Riegel - Locker	1	1	1	1	1	1	1	1	1	1	1	1	1	1						
10	259499	Bouchon de rempl. comp. Tapón de llenado completo Tappo di riempimento completo - Komplet. Einfüllverschluss - Complete Filling plug	1	1	1	1	1	1	1	1	1	1	1	1	1	1						

M

+

Catalogue : 647483

2	HYDRAULIQUE (Circuit principal) HYDRAULIK (Hauptkreis) HIDRAULICO (Circuito principal) HYDRAULIC (Principal circuit) IDRAULICO (Circuito principale)			Qte-Menge-Cant-Qty-Q.ta										10 AA 8031									
	Rep Hinw Fig Item Rif	Número Teil-Nr Numero Part-Nr Part-Nr	Désignation Bezeichnung Descripcion Description Descrizione	1	2	3	4	5	6	7	8	9	10	11	12	13	14	15	16	17	18	19	20
11	61674	Rondelle M 8 ZN Arandela Rondella	- Unterlegscheibe - Washer	1	1	1	1	1	1	1	1	1	1	1	1	1	1	1	1				
12	248096	Vis HEMB M10-25 8.8 Tornillo Vite	- Schraube - Screw	2	2	2	2	2	2	2	2	2	2	2	2	2	2	2	2				
13	58548	Ecrou H ,M12 C 8 ZN.C Tuerca Dado	- Mutter - Nut	4	4	4	4	4	4	4	4	4	4	4	4	4	4	4	4				
14	58533	Vis H,M 8-60-8.8-ZN8/C Tornillo Vite	- Schraube - Screw	1	1	1	1	1	1	1	1	1	1	1	1	1	1	1	1				
16	56354	Ecrou H ,M10 zingué Tuerca Dado	- Mutter - Nut	4	4	4	4	4	4	4	4	4	4	4	4	4	4	4	4				
17	264380	Vis H EMB M8-25 8.8-ZN8/C Tornillo Vite	- Schraube - Screw	6	6	6	6	6	6	6	6	6	6	6	6	6	6	6	6				
18	457841	Joint torique Junta tórica Anello OR	- "O" ring - "O" ring	1	1	1	1	1	1	1	1	1	1	1	1	1	1	1	1				
19	44807	Vis H,M12-25-8.8-ZN8/C Tornillo Vite	- Schraube - Screw	6	6	6	6	6	6	6	6	6	6	6	6	6	6	6	6				
20	42366	Rondelle SP10,5x30x 3ZN Arandela Rondella	- Unterlegscheibe - Washer	4	4	4	4	4	4	4	4	4	4	4	4	4	4	4	4				
21	259601	Vis H EMB M 8-20 8.8DIN6921 Tornillo Vite	- Schraube - Screw	4	4	4	4	4	4	4	4	4	4	4	4	4	4	4	4				
22	42325	Rondelle W 8 ZN Arandela Rondella	- Unterlegscheibe - Washer	1	1	1	1	1	1	1	1	1	1	1	1	1	1	1	1				

M

+

Catalogue : 647483

5	HYDRAULIQUE (Circuit principal) HYDRAULIK (Hauptkreis) HIDRAULICO (Circuito principal) HYDRAULIC (Principal circuit) IDRAULICO (Circuito principale)			Qte-Menge-Cant-Qty-Q.ta										10 AA 8031									
	Rep Hinw Fig Item Rif	Número Teil-Nr Numero Part-Nr Part-Nr	Désignation Bezeichnung Descripcion Description Descrizione	1	2	3	4	5	6	7	8	9	10	11	12	13	14	15	16	17	18	19	20
45	221172	Filt. à huile hydr. compl. Filtro aceite hidr. comp. Filtro olio idraulico comp.	- Kompletter hydr. ölfilter - Compl. hydraulic oil filter	1	1	1	1	1	1	1	1	1	1	1	1	1	1	1	1				
46	218258	Racc. Coudé Adapt. Racor Raccordo	- Verschraubung - Connection	1	1	1	1	1	1	1	1	1	1	1	1	1	1	1	1				
47	300563	Joint d'étanchéité Junta de estanqueid. Guarnizióne di tenuta	- Dichtring - Seal	1	1	1	1	1	1	1	1	1	1	1	1	1	1	1	1				
48	216267	Raccord Coudé 90° Racor Raccordo	- Verschraubung - Connection	1	1	1	1	1	1	1	1	1	1	1	1	1	1	1	1				
49	192666	Raccord Union Prolonga. Racor Raccordo	- Verschraubung - Connection	1	1	1	1	1	1	1	1	1	1	1	1	1	1	1	1				
50	210698	Levier Palanca Leva	- Hebel - Lever	1	1	1	1	1	1	1	1	1	1	1	1	1	1	1	1				
51	208546	Levier Palanca Leva	- Hebel - Lever	3	3	3	3	3	3	3	3	3	3	3	3	3	3	3	3				
52	202226	Poignée Agarrador Maniglia	- Handgriff - Handle	4	4	4	4	4	3	3	4	4	4	4	4	4	3	3	4				
53	194346	Durit Tubo flexible Manicotto	- Schlauch - Hose	1	1	1	1	1	1	1	1	1	1	1	1	1	1	1	1				
54	183026	RondelleJZC10 10,2x26x1,4CAD.BICH Arandela Rondella	- Unterlegscheibe - Washer	4	4	4	4	4	4	4	4	4	4	4	4	4	4	4	4				

M

+

Catalogue : 647483

7	HYDRAULIQUE (Circuit principal) HYDRAULIK (Hauptkreis) HIDRAULICO (Circuito principal) HYDRAULIC (Principal circuit) IDRAULICO (Circuito principale)			Qte-Menge-Cant-Qty-Q.ta										10 AA 8031									
	Rep Hinw Fig Item Rif	Numéro Teil-Nr Numero Part-Nr Part-Nr	Désignation Bezeichnung Descripcion Description Descrizione	1- M26- 2 ST3B 2- M26- 4 ST3B 3- M30- 2 ST3B 4- M30- 4 ST3B 5- M40- 2 ST3B 6- M40- 4 ST3B 7- M50- 2 ST3B 8- M50- 4 ST3B 9- M26- 2H ST3B 10-M26- 4H ST3B										11 - M30- 2H ST3B 12 - M30- 4H ST3B 13 - M40- 2H ST3B 14 - M40- 4H ST3B 15 - M50- 2H ST3B 16 - M50- 4H ST3B 17 - 18 - 19 - 20 -									
				1	2	3	4	5	6	7	8	9	10	11	12	13	14	15	16	17	18	19	20
67	185710	Durit Tubo flexible Manicotto	- Schlauch - Hose	1	1	1	1	1	1	1	1	1	1	1	1	1	1						
68	31468	Collier Abrazadera Fascetta	- Spannschelle - Clamp	2	2	2	2	2	2	2	2	2	2	2	2	2	2						
69	215536	Soufflet Fuelle Soffietto	- Blasebalg - Bellows	1	1	1	1	1	1	1	1	1	1	1	1	1							
70	311247	Distributeur Distribuidor Distributore	- Kommandosteuerventil - Valve bank	1	1	1	1	1	1	1	1	1	1	1	1	1							
71	281412	Raccord Adapteur Racor Raccordo	- Verschraubung - Connection	1	1	1	1	1	1	1	1	1	1	1	1	1							
72	307783	Levier Palanca Leva	- Hebel - Lever	1	1	1	1	1	1	1	1	1	1	1	1	1							
73	169373	Joint torique Junta tórica Anello OR	- "0" ring - "0" ring	X	X	X	X	X	X	X	X	X	X	X	X	X							
74	190876	Joint torique Junta tórica Anello OR	- "0" ring - "0" ring	X	X	X	X	X	X	X	X	X	X	X	X	X							
75	169372	Joint torique Junta tórica Anello OR	- "0" ring - "0" ring	X	X	X	X	X	X	X	X	X	X	X	X	X							
76	169374	Joint torique Junta tórica Anello OR	- "0" ring - "0" ring	X	X	X	X	X	X	X	X	X	X	X	X	X							
77	190013	Joint torique Junta tórica Anello OR	- "0" ring - "0" ring	X	X	X	X	X	X	X	X	X	X	X	X	X							

M

+

Catalogue : 647483

Rep Hinw Fig Item Rif	Numéro Teil-Nr Numero Part-Nr Part-Nr	Désignation Bezeichnung Descripcion Description Descrizione	Qte-Menge-Cant-Qty-Q.ta										10 AA 8031									
			1	2	3	4	5	6	7	8	9	10	11	12	13	14	15	16	17	18	19	20
8		HYDRAULIQUE (Circuit principal) HYDRAULIK (Hauptkreis) HIDRAULICO (Circuito principal) HYDRAULIC (Principal circuit) IDRAULICO (Circuito principale)	1- M26- 2 ST3B 2- M26- 4 ST3B 3- M30- 2 ST3B 4- M30- 4 ST3B 5- M40- 2 ST3B 6- M40- 4 ST3B 7- M50- 2 ST3B 8- M50- 4 ST3B 9- M26- 2H ST3B 10-M26- 4H ST3B										11 - M30- 2H ST3B 12 - M30- 4H ST3B 13 - M40- 2H ST3B 14 - M40- 4H ST3B 15 - M50- 2H ST3B 16 - M50- 4H ST3B 17 - 18 - 19 - 20 -									
78	190019	Joint torique Junta tórica Anello OR - "0" ring	X	X	X	X	X	X	X	X	X	X	X	X	X	X	X					
79	86788	Joint torique Junta tórica Anello OR - "0" ring	X	X	X	X	X	X	X	X	X	X	X	X	X	X	X					

M

10 AB 8032

HYDRAULIQUE (Circuit inclinaison - Elévation)
 HYDRAULIK (Neigung - Aufwinden kreis)
 HIDRAULICO (Circuito inclinación - Elevación)
 HYDRAULIC (Tilting -Lifting circuit)
 IDRAULICO (Circuito inclinazione - Sollevamento)

M 26-2/4 ST3B
 M 30-2/4 ST3B

M 26-2/4H ST3B
 M 30-2/4H ST3B

POUR FLEXIBLE ET RACCORD
 FÜR SCHLAUCH UND VERSCHRAUBUNG
 PARA FLEXIBLE Y RACOR
 FOR HOSE AND CONNECTION
 PER FLESSIBILE E RACCORDO

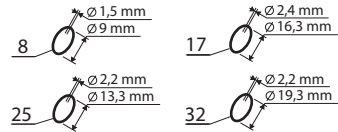

POUR TUBE - FÜR ROHR
 PARA TUBO - FOR TUBE
 PER TUBO - VOOR BUIS

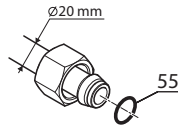

ASSEMBLY TORQUE
 10-20 BAR/145 PSI
 (SEE NOTE)

▲ SUIVANT MONTAGE
 NACH MONTAGE
 SEGUN MONTAJE
 ACCORDING TO MOUNTING
 SECONDO MONTAGGIO

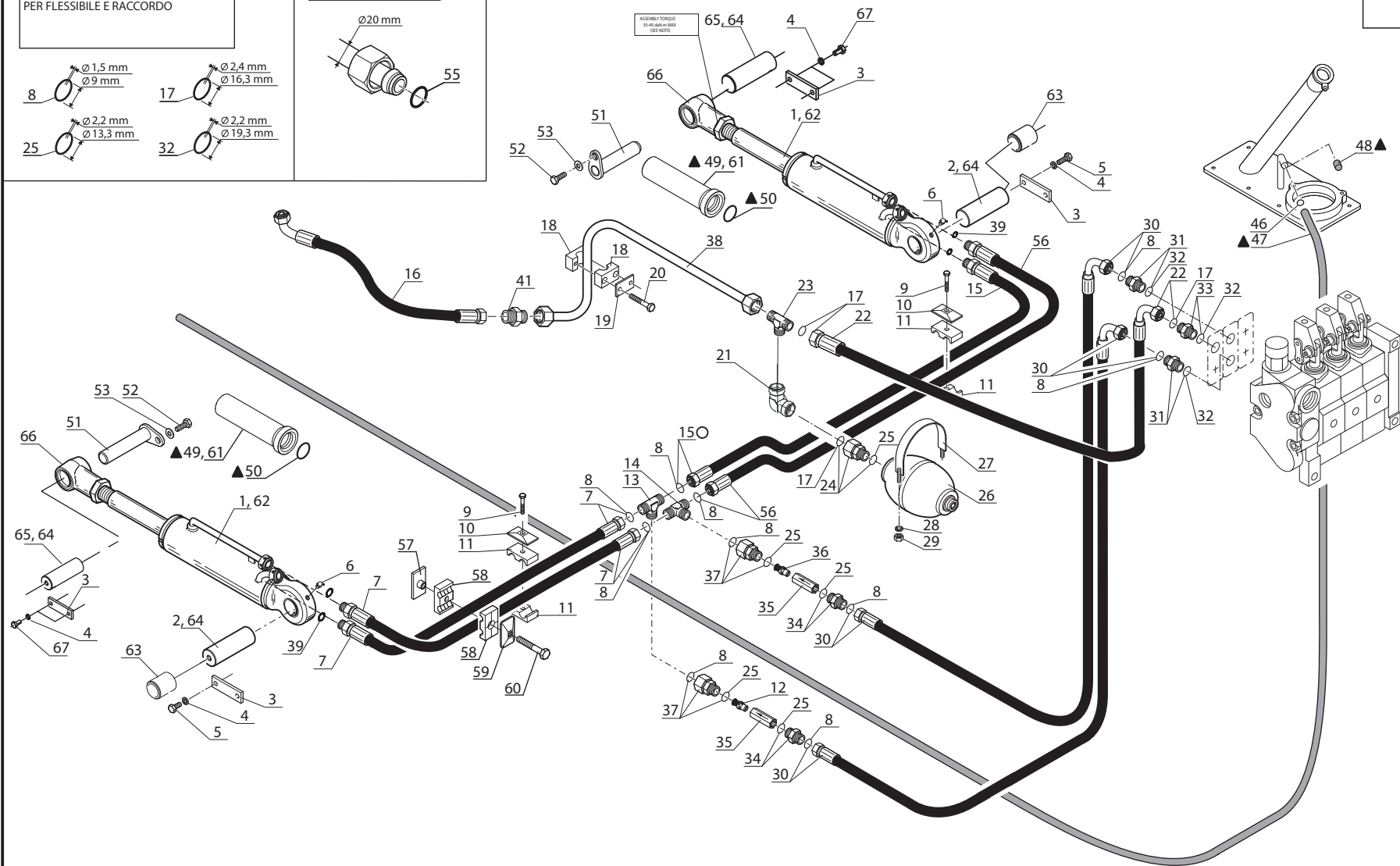

Catalogue : 647483

1	HYDRAULIQUE (Circuit incl.Elév.) HYDRAULIK (Neigung Aufwinden kre.) HIDRAULICO (Circuito inclin.Elevación) HYDRAULIC (Tilting -Lifting circuit) IDRAULICO (Circuito inclin. Sollevamento)			Qte-Menge-Cant-Qty-Q.ta										10 AB 8032									
	Rep Hinw Fig Item Rif	Numéro Teil-Nr Numero Part-Nr Part-Nr	Désignation Bezeichnung Descripcion Description Descrizione	1	2	3	4	5	6	7	8	9	10	11	12	13	14	15	16	17	18	19	20
1	51300855	Vérin inclinai.D Cilindro de inclinación Cilindro di inclinazione	- Neigungszylinder - Tilting cylinder 70x40	2	2	2	2					2	2	2	2								
2	51300971	Axe d'articulation Eje de articulación Perno di articolazione	- Gelenkachse - Articulating pin	2	2	2	2					2	2	2	2								
3	165363	Plaque de fixation Placa de fijación Piastra di fissaggio	- Befestigung Platte - Fastening plate	2	2	2	2					2	2	2	2								
4	42232	Rondelle W10 ZN Arandela Rondella	- Unterlegscheibe - Washer	4	4	4	4					4	4	4	4								
5	63727	Vis H,M10-20-8.8-ZN8/C Tornillo Vite	- Schraube - Screw	4	4	4	4					4	4	4	4								
6	55131	Graisneur coudé Engrasador acodado Ingrassatore	- Gekröpft schmiernippel - Cranked greaser	2	2	2	2					2	2	2	2								
7	307835	Flexible Flexible Flessibile	- Schlauch - Hose	2	2	2	2					2	2	2	2								
8	190874	Joint torique Junta tórica Anello OR	- "0" ring - "0" ring	X	X	X	X					X	X	X	X								
9	61323	Vis H,M8-35-8.8-ZN8/C Tornillo Vite	- Schraube - Screw	2	2	2	2					2	2	2	2								
10	168494	Plaque de protection Placa de protección Piastra di protezione	- Schutzplatte - Protection plate	2	2	2	2					2	2	2	2								
11	168492	Demi-collier Media abrazadera Fascetta	- Halb-klemme - Half-clamp	4	4	4	4					4	4	4	4								

M

+

Catalogue : 647483

Rep Hinw Fig Item Rif	Numéro Teil-Nr Numero Part-Nr Part-Nr	Désignation Bezeichnung Descripcion Description Descrizione	Qte-Menge-Cant-Qty-Q.ta										10 AB 8032									
			1- M26- 2 ST3B					11 - M30- 2H ST3B					2- M26- 4 ST3B					12 - M30- 4H ST3B				
			3- M30- 2 ST3B					13 - M40- 2H ST3B					4- M30- 4 ST3B					14 - M40- 4H ST3B				
3		HYDRAULIQUE (Circuit incl.Elév.) HYDRAULIK (Neigung Aufwinden kre.) HIDRAULICO (Circuito inclin.Elevación) HYDRAULIC (Tilting -Lifting circuit) IDRAULICO (Circuito inclin. Sollevamento)	5- M40- 2 ST3B					15 - M50- 2H ST3B					6- M40- 4 ST3B					16 - M50- 4H ST3B				
			7- M50- 2 ST3B					17 -					8- M50- 4 ST3B					18 -				
			9- M26- 2H ST3B					19 -					10-M26- 4H ST3B					20 -				
			1	2	3	4	5	6	7	8	9	10	11	12	13	14	15	16	17	18	19	20
23	89824	Raccord Té Racor Raccordo	- Verschraubung - Connection	1	1	1	1					1	1	1	1							
24	174552	Raccord Adapteur Racor Raccordo	- Verschraubung - Connection	1	1	1	1					1	1	1	1							
25	169436	Joint torique Junta tórica Anello OR	- "0" ring - "0" ring	x	x	x	x					x	x	x	x							
26	204220	Accumulateur Acumulador Accumulatore	- Akkumulator - Accumulator	1	1	1	1					1	1	1	1							
27	202661	Collier Abrazadera Fascetta	- Spannschelle - Clamp	1	1	1	1					1	1	1	1							
28	63351	Rondelle JZC 8 CAD.BICH Arandela Rondella	- Unterlegscheibe - Washer	2	2	2	2					2	2	2	2							
29	54242	Ecrou H,FR M 8 C 8 ZN..C Tuerca Dado	- Mutter - Nut	2	2	2	2					2	2	2	2							
30	171786	Flexible (Lg380) Flexible Flessibile	- Schlauch - Hose	2	2	2	2					2	2	2	2							
31	173038	Raccord Union Racor Raccordo	- Verschraubung - Connection	2	2	2	2					2	2	2	2							
32	169373	Joint torique Junta tórica Anello OR	- "0" ring - "0" ring	x	x	x	x					x	x	x	x							
33	167923	Raccord Union Racor Raccordo	- Verschraubung - Connection	1	1	1	1					1	1	1	1							

M

+

Catalogue : 647483

4	HYDRAULIQUE (Circuit incl.Elév.) HYDRAULIK (Neigung Aufwinden kre.) HIDRAULICO (Circuito inclin.Elevación) HYDRAULIC (Tilting -Lifting circuit) IDRAULICO (Circuito inclin. Sollevamento)			Qte-Menge-Cant-Qty-Q.ta										10 AB 8032									
	Rep Hinw Fig Item Rif	Número Teil-Nr Numero Part-Nr Part-Nr	Désignation Bezeichnung Descripcion Description Descrizione	1	2	3	4	5	6	7	8	9	10	11	12	13	14	15	16	17	18	19	20
34	167927	Raccord Union Racor Raccordo	- Verschraubung - Connection	2	2	2	2					2	2	2	2								
35	174231	Corps de ralentisseur Cuerpo de válvula de restricción Corpo di regolatore	- Druckregler körper - Flow restrictor body	2	2	2	2					2	2	2	2								
36	164075	Ralentisseur de débit Válvula de restricción Regolatore di flusso	- Druckregler - Flow restrictor	1	1	1	1					1	1	1	1								
37	169091	Raccord Adapteur Racor Raccordo	- Verschraubung - Connection	2	2	2	2					2	2	2	2								
38	299167	Tube Tubo Tubo	- Rohr - Tube	1	1	1	1					1	1	1	1								
39	169437	Joint d'étanchéité Junta de estanqueid. Guarnizione di tenuta	- Dichtring - Seal	4	4	4	4					4	4	4	4								
41	238229	Raccord Racor Raccordo	- Verschraubung - Connection	1	1	1	1					1	1	1	1								
46	211071	Collier Abrazadera Fascetta	- Spannschelle - Clamp	1	1	1	1					1	1	1	1								
47	203159	Durit (Lg 2300) Tubo flexible Manicotto	- Schlauch - Hose	1	1	1	1					1	1	1	1								
48	211106	Capuchon Capuchón Cappuccio	- Kappe - Cap	1	1	1	1					1	1	1	1								
49	51300980	Entretoise Separador Distanziale	- Querstrebe - Spacer, 53x40L 173	2	2	2	2					2	2	2	2								

M

+

Catalogue : 647483

Rep Hinw Fig Item Rif	Numéro Teil-Nr Numero Part-Nr Part-Nr	Désignation Bezeichnung Descripcion Description Descrizione	Qte-Menge-Cant-Qty-Q.ta										10 AB 8032									
			1- M26- 2 ST3B 2- M26- 4 ST3B 3- M30- 2 ST3B 4- M30- 4 ST3B 5- M40- 2 ST3B 6- M40- 4 ST3B 7- M50- 2 ST3B 8- M50- 4 ST3B 9- M26- 2H ST3B 10-M26- 4H ST3B										11 - M30- 2H ST3B 12 - M30- 4H ST3B 13 - M40- 2H ST3B 14 - M40- 4H ST3B 15 - M50- 2H ST3B 16 - M50- 4H ST3B 17 - 18 - 19 - 20 -									
			1	2	3	4	5	6	7	8	9	10	11	12	13	14	15	16	17	18	19	20
50	32407	Joint torique Junta tórica Anello OR - "0" ring	2	2	2	2					2	2	2	2								
51	220484	Axe d'articulation Eje de articulación Perno di articolazione - Gelenkachse - Articulating pin	2	2	2	2					2	2	2	2								
52	403357	Vis H,M10-125-25-8.8-ZN8/C Tornillo Vite - Schraube - Screw	2	2	2	2					2	2	2	2								
53	42232	Rondelle W10 ZN Arandela Rondella - Unterlegscheibe - Washer	2	2	2	2					2	2	2	2								
55	86788	Joint torique Junta tórica Anello OR - "0" ring - "0" ring	X	X	X	X					X	X	X	X								
56	307833	Flexible (Lg 550) Flexible Flessibile - Schlauch - Hose	1	1	1	1					1	1	1	1								
57	168001	Plaque d fix.(à souder) schweissen) soldar) Fastening pl(to weld) - Befestigung Plat.(zu - Placa de fijación (a - Piastra di fissaggio(a sal)	1	1	1	1					1	1	1	1								
58	168492	Demi-collier Media abrazadera Fascetta - Halb-klemme - Half-clamp	2	2	2	2					2	2	2	2								
59	168494	Plaque de protection Placa de protección Piastra di protezione - Schützplatte - Protection plate	1	1	1	1					1	1	1	1								
60	6224	Vis H,M 8-40-8.8-ZN8/C Tornillo Vite - Schraube - Screw	1	1	1	1					1	1	1	1								
61	51300981	Entretoise Separador Distanziale - Querstrebe - Spacer, 53x40L 173	2	2	2	2					2	2	2	2								

M

+

Catalogue : 647483

5	HYDRAULIQUE (Circuit incl.Elév.)) HYDRAULIK (Neigung Aufwinden kre.) HIDRAULICO (Circuito inclin.Elevación) HYDRAULIC (Tilting -Lifting circuit) IDRAULICO (Circuito inclin. Sollevamento)			Qte-Menge-Cant-Qty-Q.ta										10 AB 8032									
	Rep Hinw Fig Item Rif	Número Teil-Nr Numero Part-Nr Part-Nr	Désignation Bezeichnung Descripcion Description Descrizione	1	2	3	4	5	6	7	8	9	10	11	12	13	14	15	16	17	18	19	20
62	51300854	Vérin inclinai. Cilindro de inclinación Cilindro di inclinazione	- Neigungszylinder - Tilting cylinder 70x40	2	2	2	2					2	2	2	2								
63	51300976	Entretoise SS Spacer Distanziale	- Querstrebe - Separador	2	2	2	2					2	2	2	2								
64	4500162	Greaser Grease, ALVANIA WRO Ingrassare	- Graisse - Grasa	X	X	X	X					X	X	X	X								
65	77399	Goupille Pin Rotolo Pin	- Walzenzapfen - Perno	2	2	2	2					2	2	2	2								
66	813010	Tige de fin End, Modified Rod Canna finale	- Stange Ende - Barra de acoplamiento	2	2	2	2					2	2	2	2								
67	63544	Vis Bolt H/M10-30/30-8.8-zn8/C Vite	- Schraube - Tornillo	2	2	2	2					2	2	2	2								

M

10 AB 8033

HYDRAULIQUE (Circuit inclinaison - Elévation)
HYDRAULIK (Neigung - Aufwinden kreis)
HIDRAULICO (Circuito inclinación - Elevación)
HYDRAULIC (Tilting - Lifting circuit)
IDRAULICO (Circuito inclinazione - Sollevamento)

M 40-2/4 ST3B
M 50-2/4 ST3B

M 40-2/4H ST3B
M 50-2/4H ST3B

POUR FLEXIBLE ET RACCORD
FÜR SCHLAUCH UND VERSCHRAUBUNG
PARA FLEXIBLE Y RACOR
FOR HOSE AND CONNECTION
PER FLESSIBILE E RACCORDO

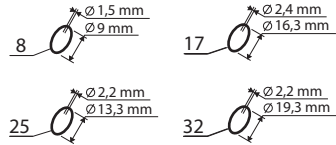

POUR TUBE - FÜR ROHR
PARA TUBO - FOR TUBE
PER TUBO - VOOR BUIS

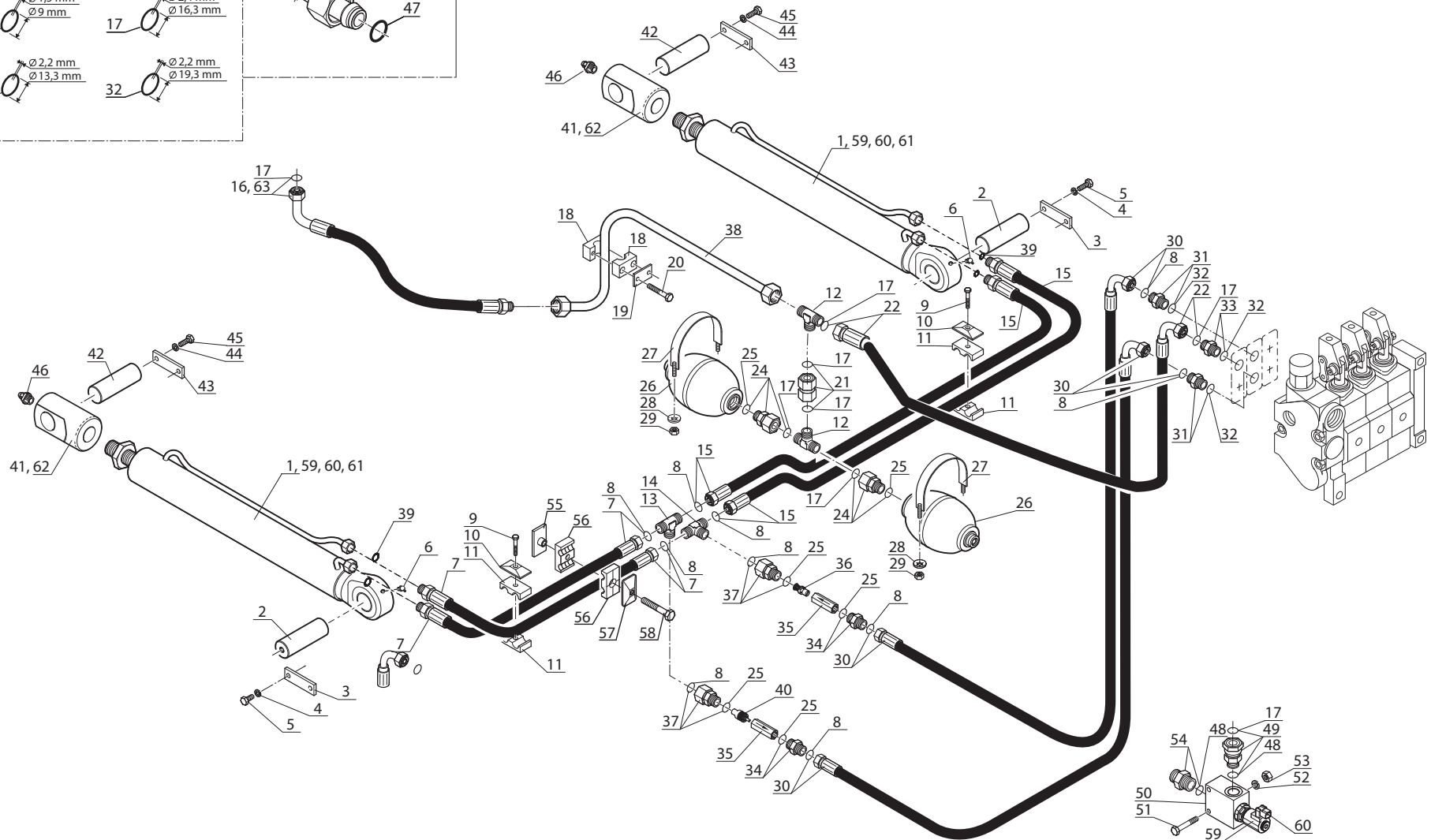
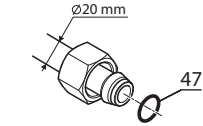

Catalogue : 647483

1	HYDRAULIQUE (Circuit incl.Elév.) HYDRAULIK (Neigung Aufwinden kre.) HIDRAULICO (Circuito inclin.Elevación) HYDRAULIC (Tilting -Lifting circuit) IDRAULICO (Circuito inclin. Sollevamento)			Qte-Menge-Cant-Qty-Q.ta										10 AB 8033									
	Rep Hinw Fig Item Rif	Numéro Teil-Nr Numero Part-Nr Part-Nr	Désignation Bezeichnung Descripcion Description Descrizione	1	2	3	4	5	6	7	8	9	10	11	12	13	14	15	16	17	18	19	20
1	219632	Vérin inclinai.D:40mmC:415mm Cilindro de inclinación Cilindro di inclinazione	- Neigungszylinder - Tilting cylinder					2	2	2	2					2	2	2	2				
2	77397	Axe d'articulation Eje de articulación Perno d articolazione	- Gelenkachse - Articulating pin					2	2	2	2					2	2	2	2				
3	165363	Plaque de fixation Placa de fijación Piastra di fissaggio	- Befestigung Platte - Fastening plate					2	2	2	2					2	2	2	2				
4	42232	Rondelle W10 ZN Arandela Rondella	- Unterlegscheibe - Washer					4	4	4	4					4	4	4	4				
5	63727	Vis H,M10-20-8.8-ZN8/C Tornillo Vite	- Schraube - Screw					4	4	4	4					4	4	4	4				
6	55131	Graisser coudé Engrasador acodado Ingrassatore	- Gekröpft schmiernippel - Cranked greaser					2	2	2	2					2	2	2	2				
7	194509	Flexible (Lg1200) Flexible Flessibile	- Schlauch - Hose					2	2	2	2					2	2	2	2				
8	190874	Joint torique Junta tórica Anello OR	- "O" ring - "O" ring					X	X	X	X					X	X	X	X				
9	61323	Vis H,M 8-35-8.8-ZN8/C Tornillo Vite	- Schraube - Screw					2	2	2	2					2	2	2	2				
10	168494	Plaque de protection Placa de protección Piastra di protezione	- Schutzplatte - Protection plate					2	2	2	2					2	2	2	2				
11	168492	Demi-collier Media abrazadera Fascetta	- Halb-klemme - Half-clamp					4	4	4	4					4	4	4	4				

M

+

Catalogue : 647483

2		HYDRAULIQUE (Circuit incl.Elév.) HYDRAULIK (Neigung Aufwinden kre.) HIDRAULICO (Circuito inclin.Elevación) HYDRAULIC (Tilting -Lifting circuit) IDRAULICO (Circuito inclin. Sollevamento)		Qte-Menge-Cant-Qty-Q.ta										10 AB 8033									
				1- M26- 2 ST3B	2- M26- 4 ST3B	3- M30- 2 ST3B	4- M30- 4 ST3B	5- M40- 2 ST3B	6- M40- 4 ST3B	7- M50- 2 ST3B	8- M50- 4 ST3B	9- M26- 2H ST3B	10-M26- 4H ST3B	11 - M30- 2H ST3B	12 - M30- 4H ST3B	13 - M40- 2H ST3B	14 - M40- 4H ST3B	15 - M50- 2H ST3B	16 - M50- 4H ST3B	17 -	18 -	19 -	20 -
Rep Hinw Fig Item Rif	Número Teil-Nr Numero Part-Nr Part-Nr	Désignation Bezeichnung Descripcion Description Descrizione		1	2	3	4	5	6	7	8	9	10	11	12	13	14	15	16	17	18	19	20
12	89824	Raccord Té Racor Raccordo	- Verschraubung - Connection					2	2	2	2					2	2	2	2				
13	168735	Raccord Té Racor Raccordo	- Verschraubung - Connection					1	1	1	1					1	1	1	1				
14	168735	Raccord Té Racor Raccordo	- Verschraubung - Connection					1	1	1	1					1	1	1	1				
15	203680	Flexible (Lg700) Flexible Flessibile	- Schlauch - Hose					2	2	2	2					2	2	2	2				
16	208154	Flexible (Lg870) Flexible Flessibile	- Schlauch - Hose					1	1	1	1					1	1	1	1				
17	86788	Joint torique Junta tórica Anello OR	- "0" ring - "0" ring					X	X	X	X					X	X	X	X				
18	168851	Demi-collier Media abrazadera Fascetta	- Halb-klemme Half-clamp					2	2	2	2					2	2	2	2				
19	168491	Plaque de protection Placa de protección Piastra di protezione	- Schützplatte - Protection plate					1	1	1	1					1	1	1	1				
20	31007	Vis H,M 6-50-8.8-ZN5/C Tornillo Vite	- Schraube - Screw					2	2	2	2					2	2	2	2				
21	76793	Raccord Racor Raccordo	- Verschraubung - Connection					1	1	1	1					1	1	1	1				
22	203676	Flexible (Lg600) Flexible Flessibile	- Schlauch - Hose					1	1	1	1					1	1	1	1				

M

+

Catalogue : 647483

3	HYDRAULIQUE (Circuit incl.Elév.) HYDRAULIK (Neigung Aufwinden kre.) HIDRAULICO (Circuito inclin.Elevación) HYDRAULIC (Tilting -Lifting circuit) IDRAULICO (Circuito inclin. Sollevamento)			Qte-Menge-Cant-Qty-Q.ta										10 AB 8033									
	Rep Hinw Fig Item Rif	Numéro Teil-Nr Numero Part-Nr Part-Nr	Désignation Bezeichnung Descripcion Description Descrizione	1- M26- 2 ST3B	2- M26- 4 ST3B	3- M30- 2 ST3B	4- M30- 4 ST3B	5- M40- 2 ST3B	6- M40- 4 ST3B	7- M50- 2 ST3B	8- M50- 4 ST3B	9- M26- 2H ST3B	10-M26- 4H ST3B	11 - M30- 2H ST3B	12 - M30- 4H ST3B	13 - M40- 2H ST3B	14 - M40- 4H ST3B	15 - M50- 2H ST3B	16 - M50- 4H ST3B	17 -	18 -	19 -	20 -
				1	2	3	4	5	6	7	8	9	10	11	12	13	14	15	16	17	18	19	20
24	174552	Raccord Adapteur Racor Raccordo	- Verschraubung - Connection					2	2	2	2					2	2	2	2				
25	169436	Joint torique Junta tórica Anello OR	- "0" ring - "0" ring					X	X	X	X				X	X	X	X					
26	204219	Accumulateur Acumulador Accumulatore	- Akkumulator - Accumulator					2	2	2	2					2	2	2	2				
27	202661	Collier Abrazadera Fascetta	- Spannschelle - Clamp					2	2	2	2					2	2	2	2				
28	63351	Rondelle JZC8CAD.BICH Arandela Rondella	- Unterlegscheibe - Washer					4	4	4	4					4	4	4	4				
29	54242	Ecrou H,FR M8C8 ZN.C Tuerca Dado	- Mutter - Nut					4	4	4	4					4	4	4	4				
30	171786	Flexible (Lg380) Flexible Flessibile	- Schlauch - Hose					2	2	2	2					2	2	2	2				
31	173038	Raccord Union Racor Raccordo	- Verschraubung - Connection					2	2	2	2					2	2	2	2				
32	169373	Joint torique Junta tórica Anello OR	- "0" ring - "0" ring					X	X	X	X				X	X	X	X					
33	167923	Raccord Union Racor Raccordo	- Verschraubung - Connection					1	1	1	1					1	1	1	1				
34	167927	Raccord Union Racor Raccordo	- Verschraubung - Connection					2	2	2	2					2	2	2	2				

M

+

Catalogue : 647483

4	HYDRAULIQUE (Circuit incl.Elév.) HYDRAULIK (Neigung Aufwinden kre.) HIDRAULICO (Circuito inclin.Elevación) HYDRAULIC (Tilting -Lifting circuit) IDRAULICO (Circuito inclin. Sollevamento)			Qte-Menge-Cant-Qty-Q.ta										10 AB 8033									
	Rep Hinw Fig Item Rif	Número Teil-Nr Numero Part-Nr Part-Nr	Désignation Bezeichnung Descripcion Description Descrizione	1	2	3	4	5	6	7	8	9	10	11	12	13	14	15	16	17	18	19	20
35	174231	Corps de ralentisseur Cuerpo de válvula de restricción Corpo di regolatore	- Druckregler körper - Flow restrictor body					2	2	2	2					2	2	2	2				
36	164075	Ralentisseur de débit Válvula de restricción Regolatore di flusso	- Druckregler - Flow restrictor					1	1	1	1					1	1	1	1				
37	169091	Raccord Adapteur Racor Raccordo	- Verschraubung - Connection					2	2	2	2					2	2	2	2				
38	300531	Tube Tubo Tubo	- Rohr - Tube					1	1	1	1					1	1	1	1				
39	169437	Joint d'étanchéité Junta de estanqueid. Guarnizione di tenuta	- Dichtring - Seal					4	4	4	4					4	4	4	4				
40	164076	Ralentisseur de débit Válvula de restriccc. Regolatore di flusso	- Druckregler - Flow restrictor					1	1	1	1					1	1	1	1				
41	219859	Embout de vérin d'incl. Cabo de cilindro de inclinación Ghiera di cilindro inclinazione	- Gabelkopf der neigezylinder - Tilt ram end tube					2	2	2	2					2	2	2	2				
42	77399	Axe d'articulation Eje de articulación Perno di articolazione	- Gelenkachse - Articulating pin					2	2	2	2					2	2	2	2				
43	165363	Plaque de fixation Placa de fijación Piastra di fissaggio	- Befestigung Platte - Fastening plate					2	2	2	2					2	2	2	2				
44	42232	Rondelle W10 ZN Arandela Rondella	- Unterlegscheibe - Washer					4	4	4	4					4	4	4	4				
45	63544	Vis H,M10-30-8.8-ZN8/C Tornillo Vite	- Schraube - Screw					4	4	4	4					4	4	4	4				

M

+

Catalogue : 647483

5	HYDRAULIQUE (Circuit incl.Elév.) HYDRAULIK (Neigung Aufwinden kre.) HIDRAULICO (Circuito inclin.Elevación) HYDRAULIC (Tilting -Lifting circuit) IDRAULICO (Circuito inclin. Sollevamento)			Qte-Menge-Cant-Qty-Q.ta										10 AB 8033									
	Rep Hinw Fig Item Rif	Numéro Teil-Nr Numero Part-Nr Part-Nr	Désignation Bezeichnung Descripcion Description Descrizione	1	2	3	4	5	6	7	8	9	10	11	12	13	14	15	16	17	18	19	20
								2	2	2	2					2	2	2	2				
46	5135	Graiss. droit(M10x150) Engrasador recto Ingrassatore destro	- Gerade schmiernippel - Straight greaser					2	2	2	2					2	2	2	2				
47	86788	Joint torique Junta tórica Anello OR	- "0" ring - "0" ring					2	2	2	2					2	2	2	2				
48	169372	Joint torique Junta torica Anello OR	- "0" ring - "0" ring					X	X	X	X					X	X	X	X				
55	168001	Plaque d fix.(àsouder) schweissen) Fastening plate (to weld)	- Befestigung Plat.(zu - Placa de fij.(a soldar) - Piast. d fissagg(a saldare)					1	1	1	1					1	1	1	1				
56	168492	Demi-collier Media abrazadera Fascetta	- Halb-klemme - Half-clamp					2	2	2	2					2	2	2	2				
57	168494	Plaque de protection Placa de protección Piastra di protezione	- Schützplatte - Protection plate					1	1	1	1					1	1	1	1				
58	6224	Vis H,M 8-40-8.8-ZN8/C Tornillo Vite	- Schraube - Screw					1	1	1	1					1	1	1	1				
59	219633	Vérin inclinai.70x40 Cilindro de inclinación Cilindro di inclinazione	- Neigungszylinder - Tilting cylinder					2	2	2	2					2	2	2	2				
60	51300860	Vérin inclinai.70x40 Cilindro de inclinación Cilindro di inclinazione	- Neigungszylinder - Tilting cylinder					2	2	2	2					2	2	2	2				
61	51300861	Vérin inclinai.70x40 Cilindro de inclinación Cilindro di inclinazione	- Neigungszylinder - Tilting cylinder					2	2	2	2					2	2	2	2				
62	813010	Tige de fin Rod End Assy Canna finale	- Stange Ende - Barra de acoplamiento					2	2	2	2					2	2	2	2				

M

Catalogue : 647483

5	HYDRAULIQUE (Circuit incl.Elév.) HYDRAULIK (Neigung Aufwinden kre.) HIDRAULICO (Circuito inclin.Elevación) HYDRAULIC (Tilting -Lifting circuit) IDRAULICO (Circuito inclin. Sollevamento)			Qte-Menge-Cant-Qty-Q.ta										10 AB 8033									
	Rep Hinw Fig Item Rif	Numéro Teil-Nr Numero Part-Nr Part-Nr	Désignation Bezeichnung Descripcion Description Descrizione	1	2	3	4	5	6	7	8	9	10	11	12	13	14	15	16	17	18	19	20
63	5130XXXX	Flexible Flexible Flessibile	- Schlauch - Hose					1	1	1	1							1	1	1	1		

M

10 AM 8034

HYDRAULIQUE (Circuit blocage differential)
HYDRAULIK (Differentialblockierung kreis)
HIDRAULICO (Circuito bloqueo diferencial)
HYDRAULIC (Differential locking circuit)
IDRAULICO (Circuito bloccaggio differenziale)

M 26-2 ST3B M 26-2H ST3B
M 30-2 ST3B M 30-2H ST3B
M 40-2 ST3B M 40-2H ST3B
M 50-2 ST3B M 50-2H ST3B

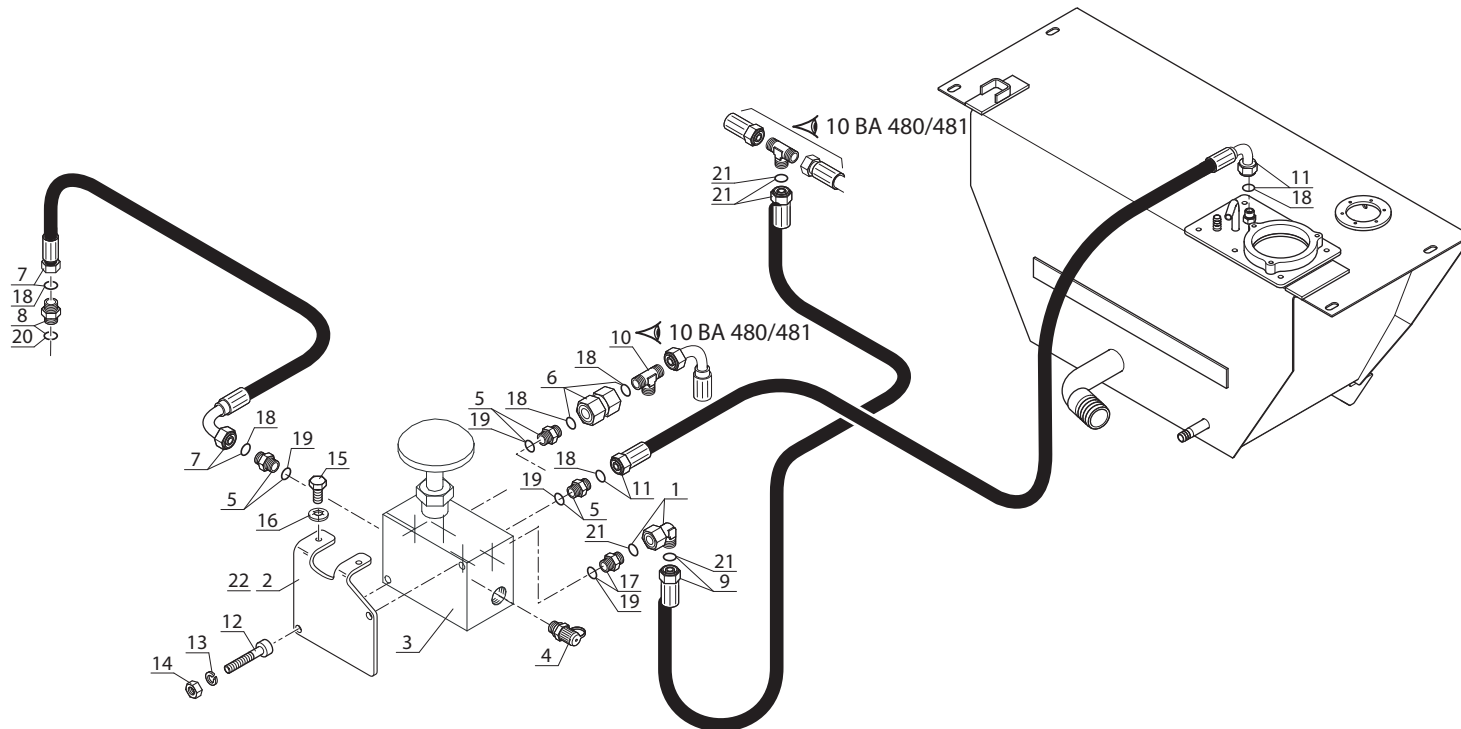

POUR FLEXIBLE ET RACCORD
FÜR SCHLAUCH UND VERSCHRAUBUNG
PARA FLEXIBLE Y RACOR
FOR HOSE AND CONNECTION
PER FLESSIBILE E RACCORDO

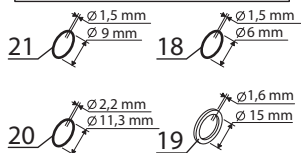

Catalogue : 647483

Rep Hinw Fig Item Rif	Numéro Teil-Nr Numero Part-Nr Part-Nr	Désignation Bezeichnung Descripcion Description Descrizione	Qte-Menge-Cant-Qty-Q.ta										10 AM 8034									
			1	2	3	4	5	6	7	8	9	10	11	12	13	14	15	16	17	18	19	20
			1		HYDRAULIQUE(Cir. bloc. diff.) HYDRAULIK (Differentialblockierung kreis) HIDRAULICO (Circuito bloqueo diferencial) HYDRAULIC (Differential locking circuit) IDRAULICO (Circuito bloccaggio differenziale)																	
1	197233	Raccord Coudé Adapteur Racor Raccordo	- Verschraubung - Connection	2		2		2		2		2		2		2		2		2		
2	51300538	Support Soporte Supporto	- Halter - Bracket	1		1				1		1										
3	306885	Valve de commande Válvula Valvola	- Ventil - Valve	1		1		1		1		1		1		1		1				
4	72339	Prise de pression Toma de presión Presa pressione	- Drückdöse - Pressure test	1		1		1		1		1		1		1		1				
5	204995	Raccord Union Racor Raccordo	- Verschraubung - Connection	3		3		3		3		3		3		3		3				
6	226342	Raccord Racor Raccordo	- Verschraubung - Connection	1		1		1		1		1		1		1		1				
7	233449	Flexible Flexible Flessibile	- Schlauch - Hose	1		1		1		1		1		1		1		1				
8	175498	Raccord Union Racor Raccordo	- Verschraubung - Connection	1		1		1		1		1		1		1		1				
9	248322	Flexible (Lg650) Flexible Flessibile	- Schlauch - Hose	1		1		1		1		1		1		1		1				
10	227458	Valve "Raccord Té" Válvula "Racor" Valvola "Raccordo"	- Vent. "Verschraubung" - Valve "Connection"	1		1		1		1		1		1		1		1				
11	224840	Flexible (Lg1950) Flexible Flessibile	- Schlauch - Hose	1		1		1		1		1		1		1		1				

+

Catalogue : 647483

2	HYDRAULIQUE(Cir. bloc. diff.) HYDRAULIK (Differentialblockierung kreis) HIDRAULICO (Circuito bloqueo diferencial) HYDRAULIC (Differential locking circuit) IDRAULICO (Circuito bloccaggio differenziale)			Qte-Menge-Cant-Qty-Q.ta										10 AM 8034									
	Rep Hinw Fig Item Rif	Número Teil-Nr Numero Part-Nr Part-Nr	Désignation Bezeichnung Descripcion Description Descrizione	1	2	3	4	5	6	7	8	9	10	11	12	13	14	15	16	17	18	19	20
12	167460	Vis CHc,M6-60-8.8-ZN5/C Tornillo Vite	- Schraube - Screw	2		2		2		2		2		2		2		2					
13	42316	Rondelle W6ZN Arandela Rondella	- Unterlegscheibe - Washer	2		2		2		2		2		2		2		2					
14	25714	Ecrou H,M6ZN Tuerca Dado	- Mutter - Nut	2		2		2		2		2		2		2		2					
15	25713	Vis H,M6-16-8.8-ZN5/C Tornillo Vite	- Schraube - Screw	2		2		2		2		2		2		2		2					
16	174132	Rondelle JZC6CAD.BICH Arandela Rondella	- Unterlegscheibe - Washer	2		2		2		2		2		2		2		2					
17	192386	Raccord Union Racor Raccordo	- Verschraubung - Connection	1		1		1		1		1		1		1		1					
18	190013	Joint torique Junta tórica Anello OR	- "0" ring - "0" ring	X		X		X		X		X		X		X		X					
19	190877	Joint torique Junta tórica Anello OR	- "0" ring - "0" ring	X		X		X		X		X		X		X		X					
20	177588	Joint torique Junta tórica Anello OR	- "0" ring - "0" ring	X		X		X		X		X		X		X		X					
21	190874	Joint torique Junta tórica Anello OR	- "0" ring - "0" ring	X		X		X		X		X		X		X		X					
22	306875	Support Soporte Supporto	- Halter - Bracket					1		1						1		1					

M

10 AA 8059

TRANSMISSION HYDROSTATIQUE
HYDROSTATISCHE GETRIEBE
TRANSMISION HYDROSTATICA
HYDROSTATIC TRANSMISSION
TRASMISSIONE IDROSTATICA

26-2/4H ST3B
30-2/4H ST3B
40-2/4H ST3B
50-2/4H ST3B

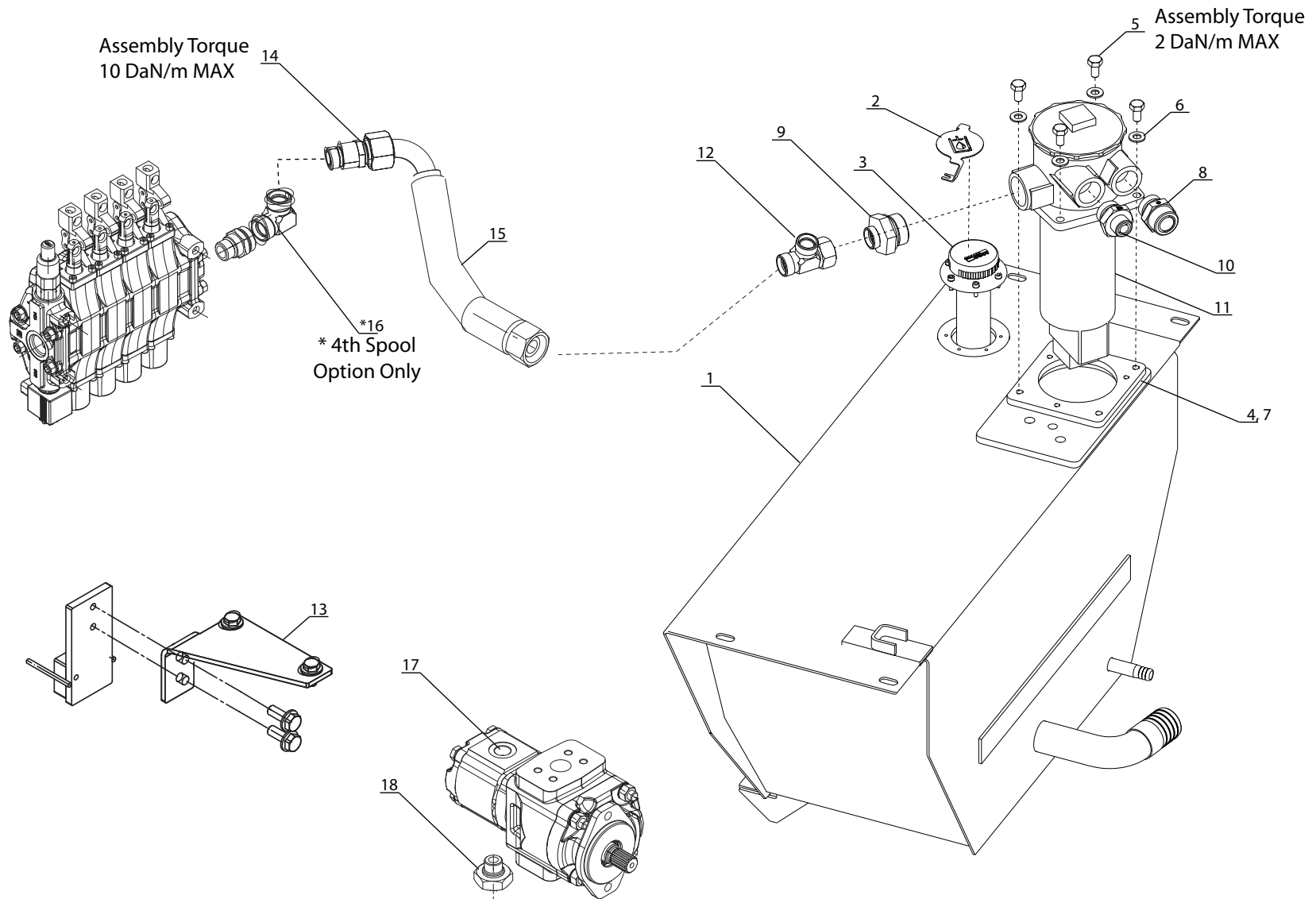

Catalogue : 647483

Rep Hinw Fig Item Rif	Numéro Teil-Nr Numero Part-Nr Part-Nr	Désignation Bezeichnung Descripcion Description Descrizione	Qte-Menge-Cant-Qty-Q.ta																	4 AB 8059																
			1- M26- 2 ST3B										11 - M30- 2H ST3B							2- M26- 4 ST3B										12 - M30- 4H ST3B						
			3- M30- 2 ST3B										13 - M40- 2H ST3B							4- M30- 4 ST3B										14 - M40- 4H ST3B						
5- M40- 2 ST3B										15 - M50- 2H ST3B							6- M40- 4 ST3B										16 - M50- 4H ST3B									
7- M50- 2 ST3B										17 -							8- M50- 4 ST3B										18 -									
9- M26- 2H ST3B										19 -							10-M26- 4H ST3B										20 -									
1	2	3	4	5	6	7	8	9	10	11	12	13	14	15	16	17	18	19	20																	
1	51300772	Réservoir complet Tank Assy Hydraulic Serbatoio completo	- Kompletter behälter - Depósito completo							1	1	1	1	1	1	1																				
2	304891	Verrouillage de remplissage d'huile Oil Fill Lock Blocco di riempimento olio	- Ölfüllung sperren - Cierre de Relleno de Aceite							1	1	1	1	1	1	1																				
3	259499	Bouchon Plug Tappo	- Stopfen - Tapón							1	1	1	1	1	1	1																				
4	802354	Joint plat Gasket Guarnizione	- Dichtung - Junta plana							1	1	1	1	1	1	1																				
5	63727	Vis Bolt, M10-1.5 X 20 Plated Hex Vite	- Schraube - Tornillo							1	1	1	1	1	1	1																				
6	29437	Rondelle Washer M 10 ZN12A/FE/CR3/I-BDM-8 Unterlegscheibe	- Unterlegscheibe - Rondelle							4	4	4	4	4	4	4																				
7	51300785	Filtre plaque de montage Filter Mounting Plate Filtro Piastra di montaggio	- Filter Montageplatte - Placa de Montage de Filtro							4	4	4	4	4	4	4																				
8	803269	Connecteur Conector, 16f42rdmlo-S Connettore	- Verbinder - Conector							1	1	1	1	1	1	1																				
9	233719	Couplage Coupling Accoppiamento	- Kupplung - Union							1	1	1	1	1	1	1																				
10	803735	Connecteur Connector Connettore	- Verbinder - Conector							1	1	1	1	1	1	1																				
11	51300969	Filtre hydrostatique Filter Hydrostatic Filtro idrostatica	- Hydrostatische Filter - Filtro Hidrostatico							1	1	1	1	1	1	1																				

M

+

Catalogue : 647483

2	TRANSMISSION HYDROSTATIQUE HYDROSTATISCHE GETRIEBE TRANSMISION HYDROSTATICA HYDROSTATIC TRANSMISSION TRASMISSIONE IDROSTATICA			Qte-Menge-Cant-Qty-Q.ta																4 AB 8062				
	Rep Hinw Fig Item Rif	Numéro Teil-Nr Numero Part-Nr Part-Nr	Désignation Bezeichnung Descripcion Description Descrizione	1	2	3	4	5	6	7	8	9	10	11	12	13	14	15	16	17	18	19	20	
12	217050	Raccord Fitting Racordo	- Verschraubung - Racor									1	1	1	1	1	1	1						
13	51300889	Angle Angle Angolo	- Winkel - Angulo									1	1	1	1	1	1	1						
14	287044	Connecteur Connection Connettore	- Verbinder - Conector									1	1	1	1	1	1	1						
15	51300938	Durit Hose/Hyd -12 x 12in Manicotto	- Schlauch - Tubo flexible									1	1	1	1	1	1	1						
16	217044	Raccord Coude Elbow MA22L Racordo	- Verschraubung - Racor									1	1	1	1	1	1	1						
17	215759	Bouchon Plug Tappo	- Stopfen - Tapón									1	1	1	1	1	1	1						
18	191707	Bouchon Plug Tappo	- Stopfen - Tapón									1	1	1	1	1	1	1						

M

10 AD 8063

MÂT - DÉPLACEMENT LATÉRAL HYDRAULIQUE KIT
MAST - HYDRAULISCHE SEITENVERSCHIEBUNG KIT
MASTIL - KIT DE DESPLAZADOR LATERAL IDRAULICO
MAST- SIDE SHIFT HYDRAULICS KIT
MAST - KIT IDRAULICO SPOSTAMENTO LATERALE

M 26-2/4 ST3BM	26-2/4H ST3B
M 30-2/4 ST3BM	30-2/4H ST3B
M 40-2/4 ST3BM	40-2/4H ST3B
M 50-4/4 ST3BM	50-4/4H ST3B

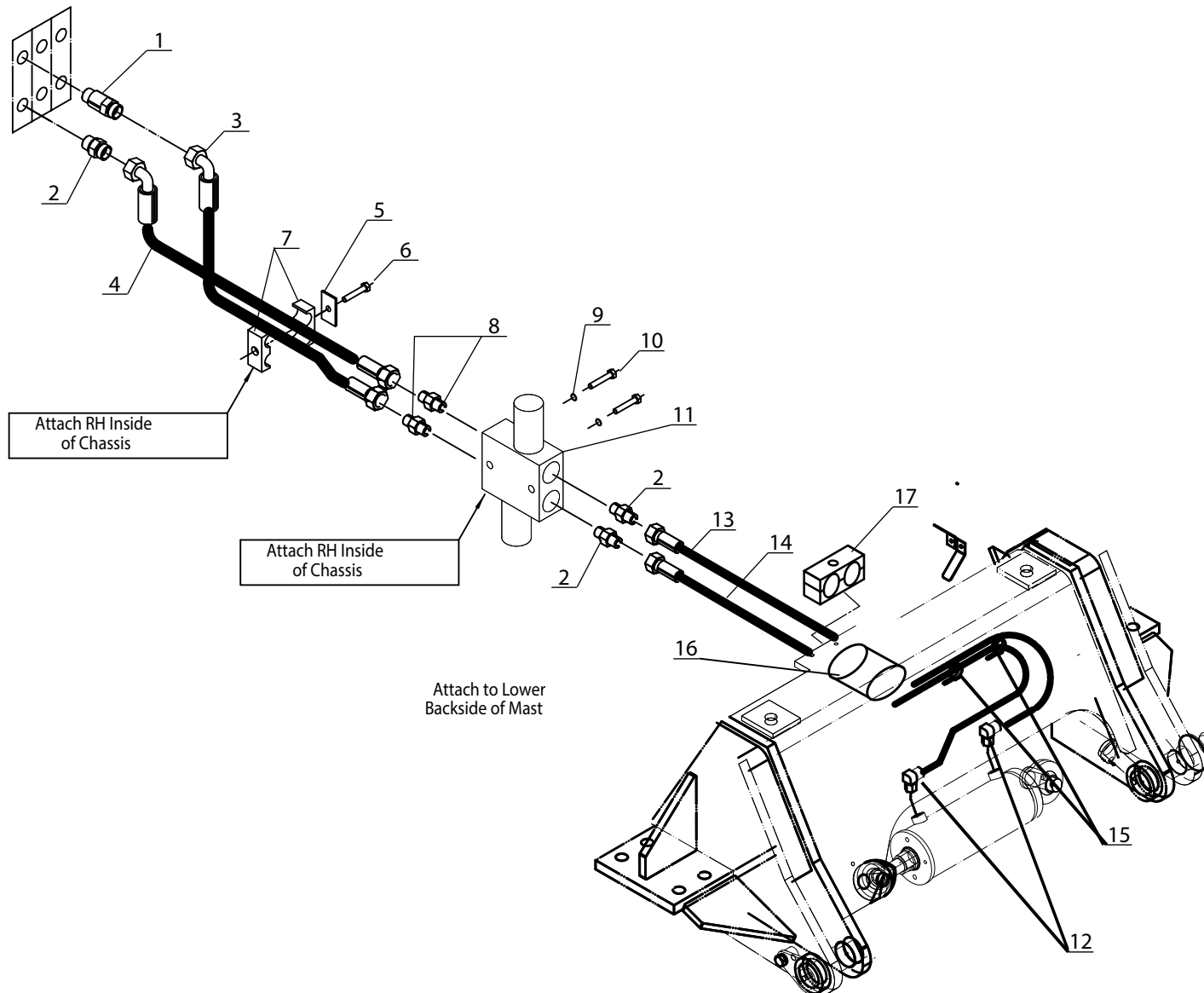

Catalogue : 647483

1	MÂT - DÉPLACEMENT LATÉRAL HYDRAULIQUE KIT MAST - HYDRAULISCHE SEITENVERSCHIEBUNG KIT MASTIL - KIT DE DESPLAZADOR LATERAL MAST- SIDE SHIFT HYDRAULICS KIT MAST - KIT IDRAULICO SPOSTAMENTO LATERALE			Qte-Menge-Cant-Qty-Q.ta										10 AD 8063									
	Rep Hinw Fig Item Rif	Numéro Teil-Nr Numero Part-Nr Part-Nr	Désignation Bezeichnung Descripcion Description Descrizione	1	2	3	4	5	6	7	8	9	10	11	12	13	14	15	16	17	18	19	20
1	5131120	Adapteur Adapter Pro+Ma16S/M22x150 Or 30 Adattore	- Adapter - Adaptador	2	2	2	2	2	2	2	2	2	2	2	2	2	2	2	2				
2	K62-6-10	Adapteur Adapter Adattore	- Adapter - Adaptador	2	2	2	2	2	2	2	2	2	2	2	2	2	2	2	2				
3	75786	Durit Hose Manicotto	- Schlauch - Tubo Flexible	1	1	1	1	1	1	1	1	1	1	1	1	1	1	1	1				
4	266177	Durit Hose.H2S13FC16S 90FC16S L 800 Manicotto	- Schlauch - Tubo Flexible	1	1	1	1	1	1	1	1	1	1	1	1	1	1	1	1				
5	168854	Plaque Plate Piastra	- Platte - Placa	3	3	3	3	3	3	3	3	3	3	3	3	3	3	3	3				
6	58530	Vis Bolt, M8-1.25 X 45 Plated Hex Vite	- Schraube - Tornillo	3	3	3	3	3	3	3	3	3	3	3	3	3	3	3	3				
7	170387	Collier Clamp Fascetta	- Klemme - Abrazadera	2	2	2	2	2	2	2	2	2	2	2	2	2	2	2	2				
8	488356	Adapteur Nipple Adattore	- Adapter - Adaptador	2	2	2	2	2	2	2	2	2	2	2	2	2	2	2	2				
9	42325	Rondelle Washer, M8 Plated Lock Rondella	- Unterlegscheibe - Arandela	2	2	2	2	2	2	2	2	2	2	2	2	2	2	2	2				
10	54951	Vis Bolt, M8-1.25 X 16 Plated Hex Vite	- Schraube - Tornillo	2	2	2	2	2	2	2	2	2	2	2	2	2	2	2	2				
11	51301039	Valve Crossover Relief Valve	- Valve - Valvula	1	1	1	1	1	1	1	1	1	1	1	1	1	1	1	1				

M

+

Catalogue : 647483

2	MÂT - DÉPLACEMENT LATÉRAL HYDRAULIQUE KIT MAST - HYDRAULISCHE SEITENVERSCHIEBUNG KIT MASTIL - KIT DE DESPLAZADOR LATERAL MAST- SIDE SHIFT HYDRAULICS KIT MAST - KIT IDRAULICO SPOSTAMENTO LATERALE			Qte-Menge-Cant-Qty-Q.ta										10 AD 8063									
	Rep Hinw Fig Item Rif	Numéro Teil-Nr Numero Part-Nr Part-Nr	Désignation Bezeichnung Descripcion Description Descrizione	1	2	3	4	5	6	7	8	9	10	11	12	13	14	15	16	17	18	19	20
12	259711	Adapteur Adapter.UN +MA16S/MA16X150 JE Adattore	- Adapter - Adaptador	2	2	2	2	2	2	2	2	2	2	2	2	2	2	2					
13	B760-1434	Durit Hose Assy Manicotto	- Schlauch - Tubo Flexible	1	1	1	1	1	1	1	1	1	1	1	1	1	1	1					
14	B760-1465	Durit Hose Assy Manicotto	- Schlauch - Tubo Flexible	1	1	1	1	1	1	1	1	1	1	1	1	1	1	1					
15	802225	Jeux de tirants Kit of tie rod Gruppo tiranti	- Spannstangensatz - Juego de tirantes	5	5	5	5	5	5	5	5	5	5	5	5	5	5	5					
16	24525-15	Emballage Wrap Imballare	- Verpacken - Embalar	1	1	1	1	1	1	1	1	1	1	1	1	1	1	1					
17	168844	Demi-collier Half-clamp Fascetta	- Halb-klemme - Media abrazadera	2	2	2	2	2	2	2	2	2	2	2	2	2	2	2					

M

10 BA 8035

HYDRAULIQUE (Circuit direction)
 HYDRAULIK (Lenkungskreis)
 HIDRAULICO (Circuito direccion)
 HYDRAULIC (Steering circuit)
 IDRAULICO (Circuito sterzo)

M 26-2 ST3B **M 26-2H ST3B**
M 30-2 ST3B **M 30-2H ST3B**
M 40-2 ST3B **M 40-2H ST3B**
M 50-2 ST3B **M 50-2H ST3B**

■ SEULEMENT POUR - NUR FÜR
 SOLAMENTE PARA - ONLY FOR - SOLO PER

□ M 30-2 ST3B

□ SEULEMENT POUR - NUR FÜR
 SOLAMENTE PARA - ONLY FOR - SOLO PER

□ M 50-2 ST3B

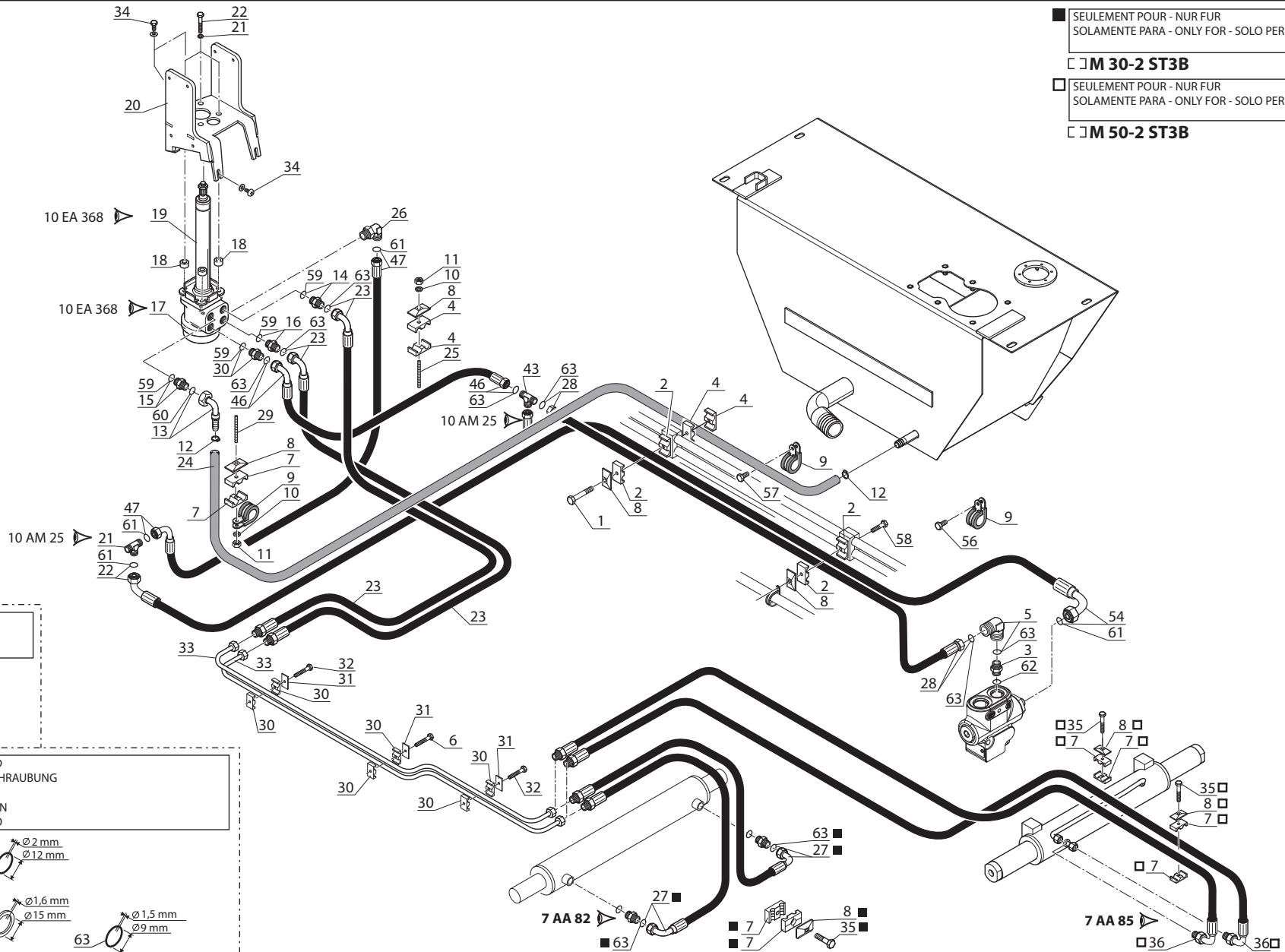

POUR TUBE - FÜR ROHR
 PARA TUBO - FOR TUBE
 PER TUBO

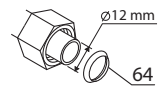

POUR FLEXIBLE ET RACCORD
 FÜR SCHLAUCH UND VERSCHRAUBUNG
 PARA FLEXIBLE Y RACOR
 FOR HOSE AND CONNECTION
 PER FLESSIBILE E RACCORDO

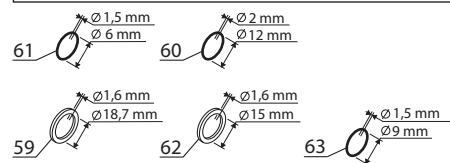

Catalogue : 647483

2	HYDRAULIQUE (Circuit direction) HYDRAULIK (Lenkungkreis) HIDRAULICO (Circuito direccion) HYDRAULIC (Steering circuit) IDRAULICO (Circuito sterzo)			Qte-Menge-Cant-Qty-Q.ta										10 BA 8035									
	Rep Hinw Fig Item Rif	Número Teil-Nr Numero Part-Nr Part-Nr	Désignation Bezeichnung Descripcion Description Descrizione	1	2	3	4	5	6	7	8	9	10	11	12	13	14	15	16	17	18	19	20
13	203240	Raccord Coudé 90° Cranté 16 Racor Raccordo	- Verschraubung - Connection	1		1		1		1		1		1		1		1					
14	482635	Raccord Union Racor Raccordo	- Verschraubung - Connection	1		1		1		1		1		1		1		1					
15	209171	Raccord Union Racor Raccordo	- Verschraubung - Connection	1		1		1		1		1		1		1		1					
16	190887	Raccord Union Racor Raccordo	- Verschraubung - Connection	2		2		2		2		2		2		2		2					
17	205960	Corps de pompe d direc Cuerpo de bomba de dirección Corpo di pompa di sterzo	- Lenkungpumpekörper - Steering pump body	1		1		1		1		1		1		1		1					
18	251784	Rondelle SP 11x20x12 Arandela Rondella	- Unterlegscheibe - Washer	4		4		4		4		4		4		4		4					
19	286875	Colonne de direction Columna de direcci Colonna sterzo	- Lenksäule - Steering column	1		1		1		1		1		1		1		1					
20	216000	Support col de direct Soporte columna de dirección Supporto colonna sterzo	- Lenksäuleträger - Steering column brac	1		1		1		1		1		1		1		1					
21	42232	Rondelle W10 ZN Arandela Rondella	- Unterlegscheibe - Washer	4		4		4		4		4		4		4		4					
22	63545	Vis H,M10-35-8.8-ZN8/C Tornillo Vite	- Schraube - Screw	4		4		4		4		4		4		4		4					
23	218082	Flexible (Lg 1250) Flexible Flessibile	- Schlauch - Hose	2		2		2		2		2		2		2		2					

M

+

Catalogue : 647483

4	HYDRAULIQUE (Circuit direction) HYDRAULIK (Lenkungkreis) HIDRAULICO (Circuito direccion) HYDRAULIC (Steering circuit) IDRAULICO (Circuito sterzo)			Qte-Menge-Cant-Qty-Q.ta										10 BA 8035									
	Rep Hinw Fig Item Rif	Número Teil-Nr Numero Part-Nr Part-Nr	Désignation Bezeichnung Descripcion Description Descrizione	1	2	3	4	5	6	7	8	9	10	11	12	13	14	15	16	17	18	19	20
				1- M26- 2 ST3B									11 - M30- 2H ST3B										
				2- M26- 4 ST3B									12 - M30- 4H ST3B										
				3- M30- 2 ST3B									13 - M40- 2H ST3B										
				4- M30- 4 ST3B									14 - M40- 4H ST3B										
				5- M40- 2 ST3B									15 - M50- 2H ST3B										
				6- M40- 4 ST3B									16 - M50- 4H ST3B										
				7- M50- 2 ST3B									17 -										
				8- M50- 4 ST3B									18 -										
				9- M26- 2H ST3B									19 -										
				10-M26- 4H ST3B									20 -										
35	61323	Vis H,M 8-35-8.8-ZN8/C Tornillo Vite	- Schraube - Screw	0		0		2		2		0		0		2		2					
36	217949	Flexible (Lg 1250) Flexible Flessibile	- Schlauch - Hose	0		0		2		2		0		0		2		2					
43	168735	Raccord Té Racor Raccordo	- Verschraubung - Connection	1		1		1		1		1		1		1		1					
46	240075	Flexible (Lg 1050) Flexible Flessibile	- Schlauch - Hose	1		1		1		1		1		1		1		1					
47	247832	Flexible (Lg 1050) Flexible Flessibile	- Schlauch - Hose H1S6FC8S90FC 8SCA	1		1		1		1		1		1		1		1					
54	76114	Flexible (Lg 1240) Flexible Flessibile	- Schlauch - Hose	1		1		1		1		1		1		1		1					
56	259946	Vis H EMB M 8-16 8.8 DIN6921 Tornillo Vite	- Schraube - Screw	1		1		1		1		1		1		1		1					
57	240822	Vis H EMB M 6-20 8.8 DIN6921 Tornillo Vite	- Schraube - Screw	1		1		1		1		1		1		1		1					
58	6224	Vis H,M 8- 40-8.8-ZN8/C Tornillo Vite	- Schraube - Screw	1		1		1		1		1		1		1		1					
59	184787	Joint torique Junta tórica Anello OR	- "0" ring - "0" ring	X		X		X		X		X		X		X		X					
60	189956	Joint torique Junta tórica Anello OR	- "0" ring - "0" ring	X		X		X		X		X		X		X		X					

M

+

10 BA 8036

HYDRAULIQUE (Circuit direction)
 HYDRAULIK (Lenkungkreis)
 HIDRAULICO (Circuito direccion)
 HYDRAULIC (Steering circuit)
 IDRAULICO (Circuito sterzo)

M 26-4 ST3B M 26-4H ST3B
 M 30-4 ST3B M 30-4H ST3B
 M 40-4 ST3B M 40-4H ST3B
 M 50-4 ST3B M 50-4H ST3B

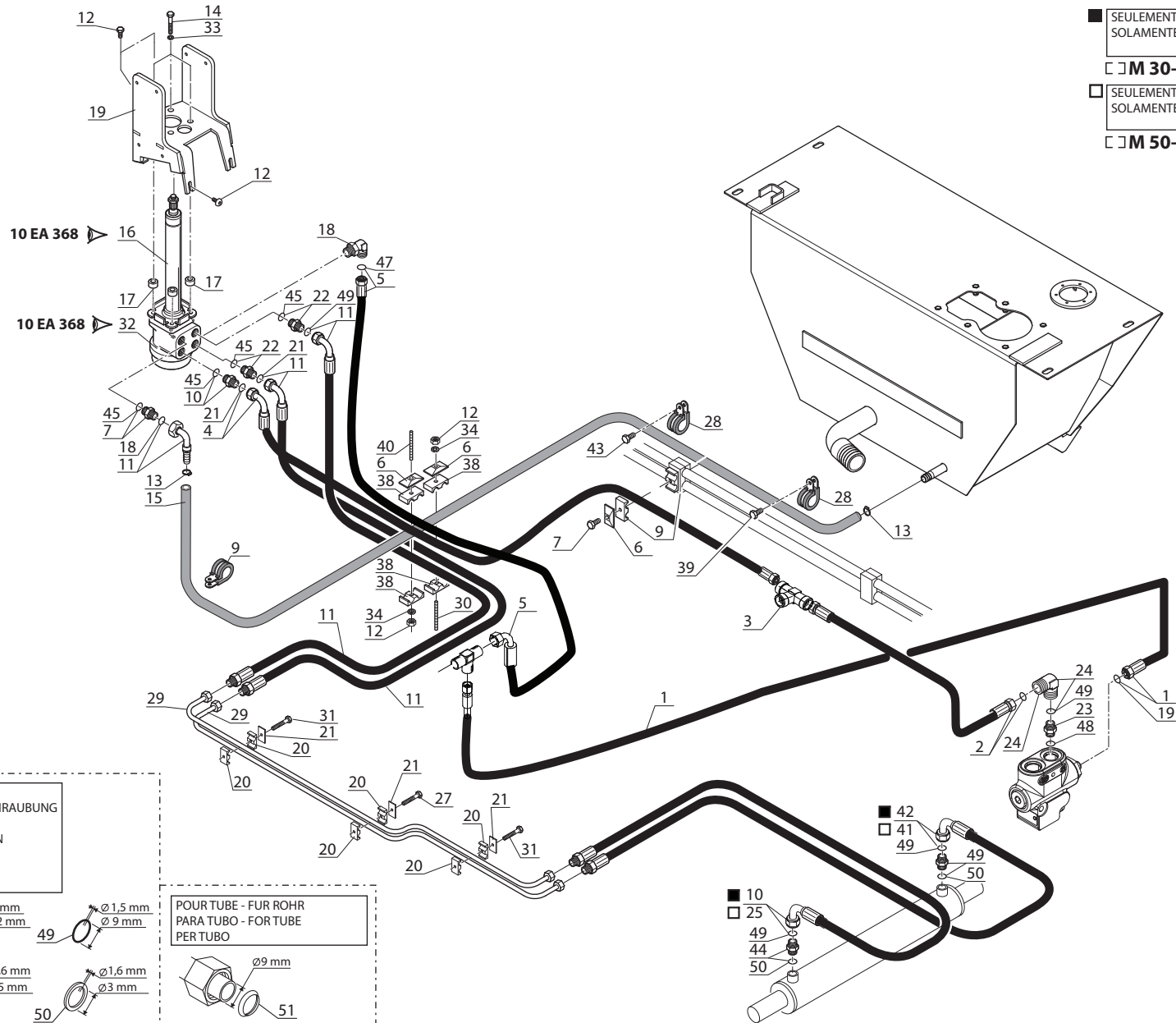

■ SEULEMENT POUR - NUR FÜR
 SOLAMENTE PARA - ONLY FOR - SOLO PER

□ M 30-4 ST3B

□ SEULEMENT POUR - NUR FÜR
 SOLAMENTE PARA - ONLY FOR - SOLO PER

□ M 50-4 ST3B

POUR FLEXIBLE ET RACCORD
 FÜR SCHLAUCH UND VERSCHRAUBUNG
 PARA FLEXIBLE Y RACOR
 FOR HOSE AND CONNECTION
 PER FLESSIBILE E RACCORDO

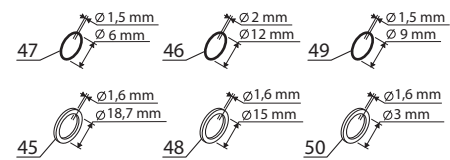

POUR TUBE - FÜR ROHR
 PARA TUBO - FOR TUBE
 PERTUBO

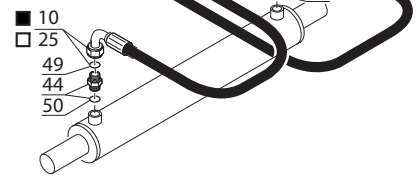

Catalogue : 647483

Rep Hinw Fig Item Rif	Numéro Teil-Nr Numero Part-Nr Part-Nr	Désignation Bezeichnung Descripcion Description Descrizione	Qte-Menge-Cant-Qty-Q.ta										10 BA 8036									
			1- M26- 2 ST3B 2- M26- 4 ST3B 3- M30- 2 ST3B 4- M30- 4 ST3B 5- M40- 2 ST3B 6- M40- 4 ST3B 7- M50- 2 ST3B 8- M50- 4 ST3B 9- M26- 2H ST3B 10-M26- 4H ST3B										11 - M30- 2H ST3B 12 - M30- 4H ST3B 13 - M40- 2H ST3B 14 - M40- 4H ST3B 15 - M50- 2H ST3B 16 - M50- 4H ST3B 17 - 18 - 19 - 20 -									
			1	2	3	4	5	6	7	8	9	10	11	12	13	14	15	16	17	18	19	20
1	76114	Flexible (Lg1240) Flexible Flessibile - Schlauch - Hose		1		1			1		1			1		1			1			
2	304246	Flexible (Lg550) Flexible Flessibile - Schlauch - Hose		1		1			1		1			1		1			1			
3	168735	Raccord Té Racor Raccordo - Verschraubung - Connection		1		1			1		1			1		1			1			
4	240075	Flexible (Lg1050) Flexible Flessibile - Schlauch - Hose		1		1			1		1			1		1			1			
5	247832	Flexible Flexible Flessibile - Schlauch - Hose		1		1			1		1			1		1			1			
6	168494	Plaque de protection Placa de protección Piastra di protezione - Schützplatte - Protection plate		4		4			4		4			4		4			4			
7	6224	Vis H,M 8-40-8.8-ZN8/C Tornillo Vite - Schraube - Screw		1		1			1		1			1		1			1			
8	58533	Vis H,M 8-60-8.8-ZN8/C Tornillo Vite - Schraube - Screw		1		1			1		1			1		1			1			
9	268218	Demi-collier Media abrazadera Fascetta - Halb-klemme - Half-clamp		4		4			4		4			4		4			4			
10	201118	Flexible (Lg490) Flexible Flessibile - Schlauch - Hose		1		1					1			1								
11	218082	Flexible (Lg1250) Flexible Flessibile - Schlauch - Hose		2		2			2		2			2		2			2			

M

+

Catalogue : 647483

2	HYDRAULIQUE (Circuit direction) HYDRAULIK (Lenkungkreis) HIDRAULICO (Circuito direccion) HYDRAULIC (Steering circuit) IDRAULICO (Circuito sterzo)			Qte-Menge-Cant-Qty-Q.ta										10 BA 8036									
	Rep Hinw Fig Item Rif	Número Teil-Nr Numero Part-Nr Part-Nr	Désignation Bezeichnung Descripcion Description Descrizione	1	2	3	4	5	6	7	8	9	10	11	12	13	14	15	16	17	18	19	20
12	58528	Ecrou H ,M 8ZN Tuerca Dado	- Mutter - Nut		2		2		2		2		2		2		2		2				
13	203512	Collier Abrazadera Fascetta	- Spannschelle - Clamp		2		2		2		2		2		2		2		2				
14	63545	Vis H,M10-35-8.8-ZN8/C Tornillo Vite	- Schraube - Screw		4		4		4		4		4		4		4		4				
15	292257	Durit Tubo flexible Manicotto	- Schlauch - Hose		1		1		1		1		1		1		1		1				
16	286875	Colonne de direction Columna de direcci Colonna sterzo	- Lenksäule - Steering column		1		1		1		1		1		1		1		1				
17	251784	Rondelle SP11x20x12 Arandela Rondella	- Unterlegscheibe - Washer		4		4		4		4		4		4		4		4				
18	225521	Raccord Coudé Racor Raccordo	- Verschraubung - Connection		1		1		1		1		1		1		1		1				
19	216000	Support colon. d direc. Sop. col. de direc. Supporto col. sterzo	- Lenksäule träger - Steering col. bracket		1		1		1		1		1		1		1		1				
20	168844	Demi-collier Media abrazadera Fascetta	- Halb-klemme - Half-clamp		6		6		6		6		6		6		6		6				
21	168849	Plaque de protection Placa de proteccion Piastra di protezione	- Schutzplatte - Protection plate		3		3		3		3		3		3		3		3				
22	190887	Raccord Union Racor Raccordo	- Verschraubung - Connection		2		2		2		2		2		2		2		2				

M

+

Catalogue : 647483

3	HYDRAULIQUE (Circuit direction) HYDRAULIK (Lenkungskreis) HIDRAULICO (Circuito direccion) HYDRAULIC (Steering circuit) IDRAULICO (Circuito sterzo)			Qte-Menge-Cant-Qty-Q.ta										10 BA 8036									
	Rep Hinw Fig Item Rif	Número Teil-Nr Numero Part-Nr Part-Nr	Désignation Bezeichnung Descripcion Description Descrizione	1	2	3	4	5	6	7	8	9	10	11	12	13	14	15	16	17	18	19	20
23	189991	Raccord Racor Raccordo	- Verschraubung - Connection		1		1		1		1		1		1		1		1				
24	168758	Demi-collier Media abrazadera Fascetta	- Halb-klemme - Half-clamp		2		2		2		2		2		2		2		2				
25	173039	Flexible Flexible Flessibile	- Schlauch - Hose						1		1					1		1					
26	209171	Raccord Union Racor Raccordo	- Verschraubung - Connection		1		1		1		1		1		1		1		1				
27	29481	Vis H,M6-45-8.8-ZN5/C Tornillo Vite	- Schraube - Screw		1		1		1		1		1		1		1		1				
28	86506	Collier Abrazadera Fascetta	- Spannschelle - Clamp		3		3		3		3		3		3		3		3				
29	303004	Tube Tubo Tubo	- Rohr - Tube		2		2		2		2		2		2		2		2				
30	282221	Vis AHc,M8-120-33H-ZINTEK AG Tornillo Vite	- Schraube - Screw		1		1		1		1		1		1		1		1				
31	54284	Vis H,M 6- 35-8.8-ZN5/C Tornillo Vite	- Schraube - Screw		2		2		2		2		2		2		2		2				
32	205960	Corps de pompe de direction Cuerpo de bomba de direcci6n Corpo di pompa di sterzo	- Lenkung pompe k6rper - Steering pump body		1		1		1		1		1		1		1		1				
33	42232	Rondelle W10 ZN Arandela Rondella	- Unterlegscheibe - Washer		4		4		4		4		4		4		4		4				

M

+

Catalogue : 647483

5	HYDRAULIQUE (Circuit direction) HYDRAULIK (Lenkungkreis) HIDRAULICO (Circuito direccion) HYDRAULIC (Steering circuit) IDRAULICO (Circuito sterzo)			Qte-Menge-Cant-Qty-Q.ta										10 BA 8036									
	Rep Hinw Fig Item Rif	Número Teil-Nr Numero Part-Nr Part-Nr	Désignation Bezeichnung Descripcion Description Descrizione	1	2	3	4	5	6	7	8	9	10	11	12	13	14	15	16	17	18	19	20
45	184787	Joint torique Junta tórica Anello OR	- "0" ring - "0" ring		X		X		X		X		X		X		X		X				
46	189956	Joint torique Junta tórica Anello OR	- "0" ring - "0" ring		X		X		X		X		X		X		X		X				
47	190013	Joint torique Junta tórica Anello OR	- "0" ring - "0" ring		X		X		X		X		X		X		X		X				
48	190877	Joint torique Junta tórica Anello OR	- "0" ring - "0" ring		X		X		X		X		X		X		X		X				
49	190874	Joint torique Junta tórica Anello OR	- "0" ring - "0" ring		X		X		X		X		X		X		X		X				
50	177637	Joint torique Junta tórica Anello OR	- "0" ring - "0" ring		X		X		X		X		X		X		X		X				
51	190874	Joint torique Junta tórica Anello OR	- "0" ring - "0" ring		X		X		X		X		X		X		X		X				

M

HYDRAULIQUE (Vérin d'inclinaison) (Inclinaison standard 15°/15°) IDRAULICO (Cilindro di inclinazione)
 HYDRAULIK (Neigungszylinder) (Standard neigung 15°/15°) (Inclinazione standard 15°/15°)
 HIDRAULICO (Cilindro de inclinación) (Inclinación estandard 15°/15°)
 HYDRAULIC (Tilting cylinder) (Standard tilting 15°/15°)

M 40-2/4 ST3B M 50-2/4 ST3B
 M 40-2/4H ST3B M 50-2/4H ST3B

10 CD 8037

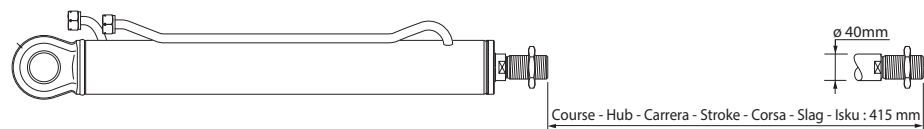

- NON LIVRE AVEC VERIN
 NICHT GELIEFERT MIT ZYLINDER
 NO ENTREGADOS CON CILINDRO
 NOT DELIVERED WITH CYLINDER
 NON CONSEGNARE CON CILINDRO
- 1er MONTAGE
 1ste MONTAGE
 1ro MONTAJE
 1st MOUNTING
 1mo MONTAGGIO
- 2ème MONTAGE
 2te MONTAGE
 2do MONTAJE
 2nd MOUNTING
 2do MONTAGGIO

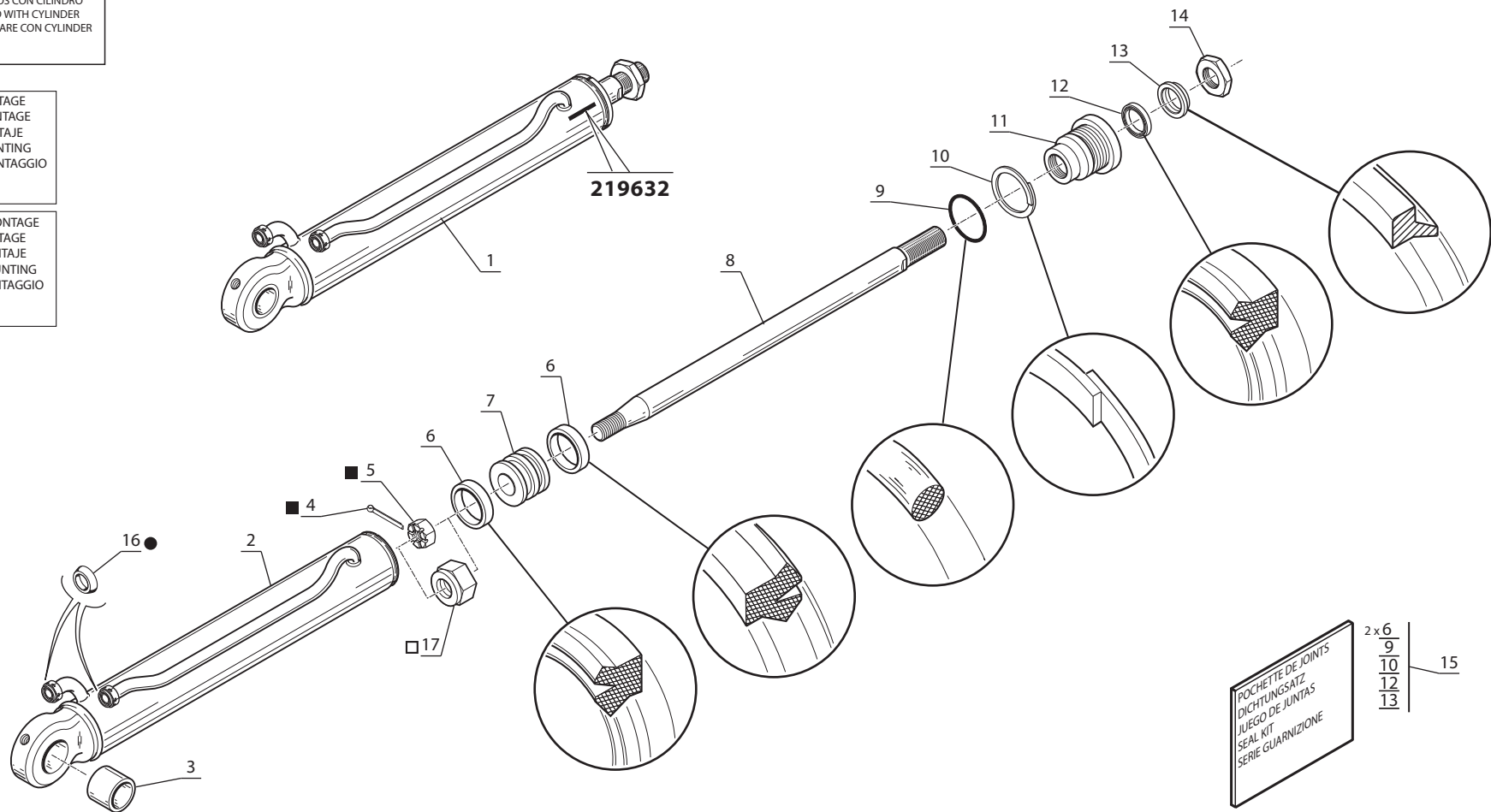

Catalogue : 647483

Rep Hinw Fig Item Rif	Numéro Teil-Nr Numero Part-Nr Part-Nr	Désignation Bezeichnung Descripcion Description Descrizione	Qte-Menge-Cant-Qty-Q.ta										10 CD 8037									
			1	2	3	4	5	6	7	8	9	10	11	12	13	14	15	16	17	18	19	20
1		HYDRAULIQUE (Vérin d'inclinaison) (Inclinaison standard 15°/15°) HYDRAULIK (Neigungszylinder)(St. neigung 15°/15°) HIDRAULICO (Cilindro de inclinación)(Inclinación estandard 15°/15°) HYDRAULIC (Tilting cylinder)(Standard tilting 15°/15°) IDRAULICO (Cilindro di inclinazione) (Inclinazione standard 15°/15°)	1- M26- 2 ST3B 2- M26- 4 ST3B 3- M30- 2 ST3B 4- M30- 4 ST3B 5- M40- 2 ST3B 6- M40- 4 ST3B 7- M50- 2 ST3B 8- M50- 4 ST3B 9- M26- 2H ST3B 10-M26- 4H ST3B	11 - M30- 2H ST3B 12 - M30- 4H ST3B 13 - M40- 2H ST3B 14 - M40- 4H ST3B 15 - M50- 2H ST3B 16 - M50- 4H ST3B 17 - 18 - 19 - 20 -																		
1	219632	Vérin inclinai. D:40mm C:415mm Cilindro de inclinación Cilindro di inclinazione	- Neigungszylinder - Tilting cylinder					2	2	2	2							2	2	2	2	
2	181257	Corps de vérin Cuerpo de cilindro Camicia del cilindro	- Zylinder körper - Cylinder body					1	1	1	1							1	1	1	1	
3	181246	Bague Anillo Anello	- Büchse - Bushing					1	1	1	1							1	1	1	1	
4	42811	Goupille V5x63 zinguée Pasador Spina	- Stift - Pin					1	1	1	1							1	1	1	1	
5	31717	Ecrou HK,M30-200zingué Tuerca Dado	- Mutter - Nut					1	1	1	1							1	1	1	1	
6	19953	Joint d'étanchéité Junta de estanquei. Guarnizione	- Dichtungsring - Seal					2	2	2	2							2	2	2	2	
7	31721	Piston de vérin Pistón de cilindro Pistone del cilindro	- Zylinderkolben - Cylinder piston					1	1	1	1							1	1	1	1	
8	181258	Tige de vérin Vástago de cilindro Stelo del cilindro	- Zylinder stange - Cylinder rod					1	1	1	1							1	1	1	1	
9	4040	Joint torique Junta tórica Anello OR	- "O" ring - "O" ring					1	1	1	1							1	1	1	1	
10	182268	Joint anti-extrusion Junta antiextrusión Guarnizione anti estrusione	- Abstützdichtung - Anti-extrusion seal					1	1	1	1							1	1	1	1	

M

+

Catalogue : 647483

Rep Hinw Fig Item Rif	Numéro Teil-Nr Numero Part-Nr Part-Nr	Désignation Bezeichnung Descripcion Description Descrizione	Qte-Menge-Cant-Qty-Q.ta										10 CD 8037									
			1	2	3	4	5	6	7	8	9	10	11	12	13	14	15	16	17	18	19	20
2		HYDRAULIQUE (Vérin d'inclinaison) (Inclinaison standard 15°/15°) HYDRAULIK (Neigungszylinder)(St. neigung 15°/15°) HIDRAULICO (Cilindro de inclinación)(Inclinación estandard 15°/15°) HYDRAULIC (Tilting cylinder)(Standard tilting 15°/15°)																				
11	186755	Bague de fermeture Anillo de cierre Anello di chiusura	- Schlussring - Fastening ring					1	1	1	1											
12	5316	Joint d'étanchéité Junta de estanque Guarnizióne	- Dichtungsring - Seal					1	1	1	1				1	1	1	1				
13	1878	Joint d'étanchéité Junta de estanque Guarnizióne	- Dichtungsring - Seal					1	1	1	1				1	1	1	1				
14	19959	Ecrou Tuerca Dado	- Mutter - Nut					1	1	1	1				1	1	1	1				
15	186760	Pochette de joints Juego de juntas Serie guarnizióne	- Dichtungssatz - Seal kit					1	1	1	1				1	1	1	1				
16	169437	Joint d'étanchéité Junta de estanquei Guarnizióne	- Dichtungsring - Seal					2	2	2	2				2	2	2	2				
17	165292	Ecrou FR, M30-200 Tuerca Dado	- Mutter - Nut					1	1	1	1				1	1	1	1				

M

1- M26- 2 ST3B	11 - M30- 2H ST3B
2- M26- 4 ST3B	12 - M30- 4H ST3B
3- M30- 2 ST3B	13 - M40- 2H ST3B
4- M30- 4 ST3B	14 - M40- 4H ST3B
5- M40- 2 ST3B	15 - M50- 2H ST3B
6- M40- 4 ST3B	16 - M50- 4H ST3B
7- M50- 2 ST3B	17 -
8- M50- 4 ST3B	18 -
9- M26- 2H ST3B	19 -
10-M26- 4H ST3B	20 -

10 CD 8038

HYDRAULIQUE (Vérin d'inclinaison) (Inclinaison standard 6°/12°)
 HYDRAULIK (Neigungszylinder) (Standard neigung 6°/12°)
 HIDRAULICO (Cilindro de inclinación) (Inclinación estandar 6°/12°)
 HYDRAULIC (Tilting cylinder) (Standard tilting 6°/12°)

IDRAULICO (Cilindro di inclinazione)
 (Inclinazione standard 6°/12°)

M 26-2/4 ST3B
M 30-2/4 ST3B

M 26-2/4H ST3B
M 30-2/4H ST3B

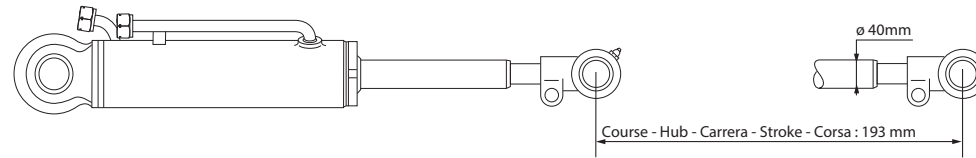

◆ NON LIVRE AVEC VERIN
 NICHT GELIEFERT MIT ZYLINDER
 NO ENTREGADOS CON CILINDRO
 NOT DELIVERED WITH CYLINDER
 NON CONSEGNARE CON CYLINDER

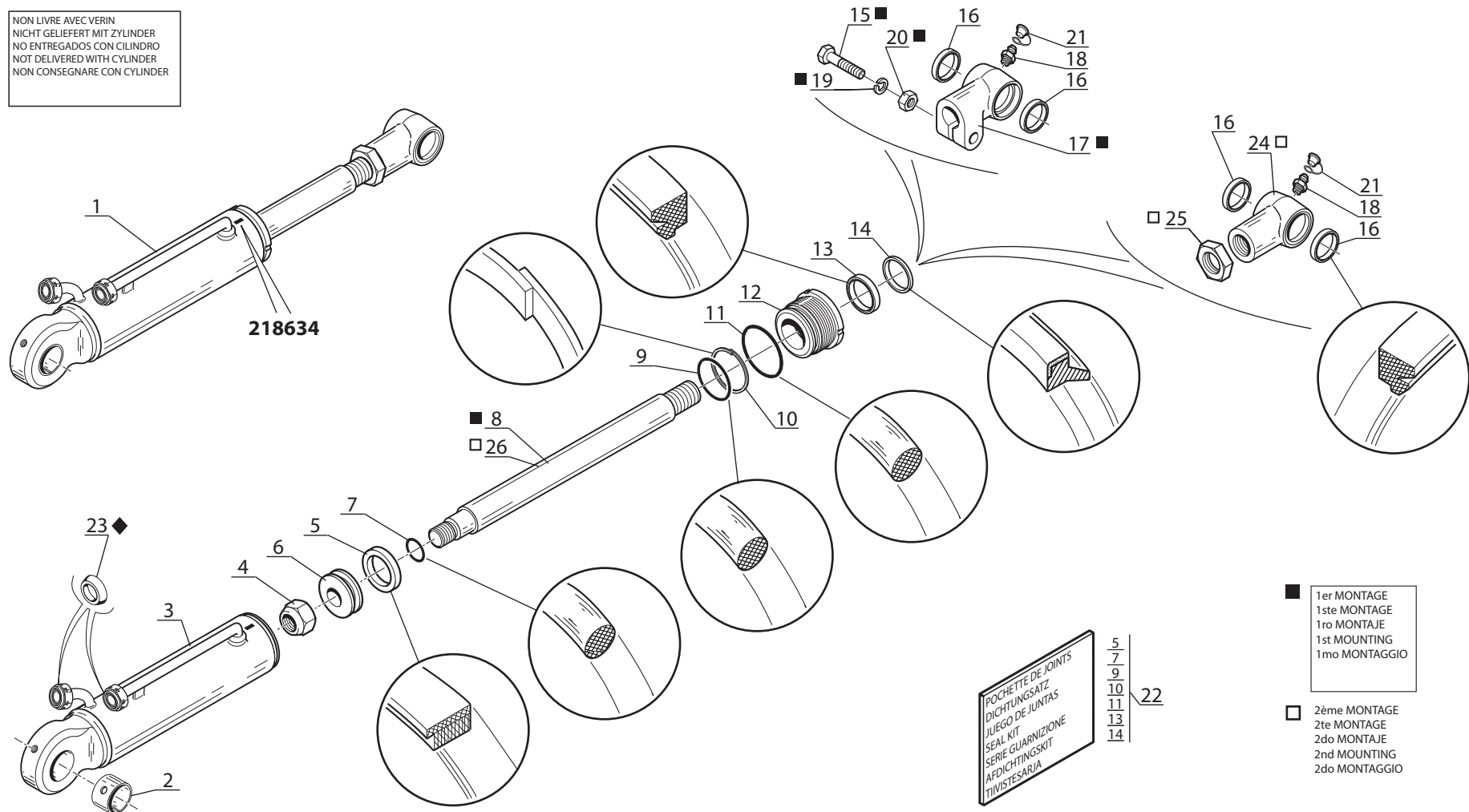

POCHETTE DE JOINTS
 DICHTUNGSATZ
 JUEGO DE JUNTAS
 SEAL KIT
 SERIE GUARNIZIONE
 ARDICHTINGSKIT
 TIIVISTESARJA

■ 1er MONTAGE
 1ste MONTAGE
 1ro MONTAJE
 1st MOUNTING
 1mo MONTAGGIO

□ 2ème MONTAGE
 2te MONTAGE
 2do MONTAJE
 2nd MOUNTING
 2do MONTAGGIO

Catalogue : 647483

Rep Hinw Fig Item Rif	Numéro Teil-Nr Numero Part-Nr Part-Nr	Désignation Bezeichnung Descripcion Description Descrizione	Qte-Menge-Cant-Qty-Q.ta										10 CD 8038									
			1	2	3	4	5	6	7	8	9	10	11	12	13	14	15	16	17	18	19	20
1		HYDRAULIQUE (Vérin d'inclinaison) (Inclinaison standard 6°/12°) HYDRAULIK (Neigungszylinder)(St. neigung 6°/12°) HIDRAULICO (Cilindro de inclinación)(Inclinación estandard 6°/12°) HYDRAULIC (Tilting cylinder)(Standard tilting 6°/12°) IDRAULICO (Cilindro di inclinazione) (Inclinazione standard 6°/12°)	11 - M30- 2H ST3B 12 - M30- 4H ST3B 13 - M40- 2H ST3B 14 - M40- 4H ST3B 15 - M50- 2H ST3B 16 - M50- 4H ST3B 17 - 18 - 19 - 20 -																			
1	218634	Vérin inclinai. D:40mm C:193mm Cilindro de inclinación Cilindro di inclinazione	- Neigungszylinder - Tilting cylinder	2	2	2	2					2	2	2	2							
2	181246	Bague Anillo Anello	- Büchse - Bushing	1	1	1	1					1	1	1	1							
3	562138	Corps de vérin Cuerpo de cilindro Corpo di cilindro	- Zylinder körper - Cylinder body	1	1	1	1					1	1	1	1							
4	165292	Ecrou FR, M30-200 Tuerca Dado	- Mutter - Nut	1	1	1	1					1	1	1	1							
5	548126	Joint d'étanchéité Junta de estanquei Guarnizione	- Dichtungsring - Seal	1	1	1	1					1	1	1	1							
6	549246	Piston de vérin Pistón de cilindro Pistone del cilindro	- Zylinderkolben - Cylinder piston	1	1	1	1					1	1	1	1							
7	172830	Joint torique Junta tórica Anello OR	- "0" ring - "0" ring	1	1	1	1					1	1	1	1							
8	565587	Tige de vérin Vástago de cilindro Stelo del cilindro	- Zylinder stange - Cylinder rod	1	1	1	1					1	1	1	1							
9	4040	Joint torique Junta tórica Anello OR	- "0" ring - "0" ring	1	1	1	1					1	1	1	1							
10	182268	Joint anti-extrusion Junta antiextrusión Guarnizione anti estrusione	- Abstützdichtung - Anti-extrusion seal	1	1	1	1					1	1	1	1							
11	161783	Joint torique Junta tórica Anello OR	- "0" ring - "0" ring	1	1	1	1					1	1	1	1							

M

+

Catalogue : 647483

Rep Hinw Fig Item Rif	Numéro Teil-Nr Numero Part-Nr Part-Nr	Désignation Bezeichnung Descripcion Description Descrizione	Qte-Menge-Cant-Qty-Q.ta										10 CD 8038									
			1	2	3	4	5	6	7	8	9	10	11	12	13	14	15	16	17	18	19	20
2		HYDRAULIQUE (Vérin d'inclinaison) (Inclinaison standard 6°/12°) HYDRAULIK (Neigungszylinder)(St. neigung 6°/12°) HIDRAULICO (Cilindro de inclinación)(Inclinación estandard 6°/12°) HYDRAULIC (Tilting cylinder)(Standard tilting 6°/12°) IDRAULICO (Cilindro di inclinazione) (Inclinazione standard 6°/12°)	1- M26- 2 ST3B	11 - M30- 2H ST3B																		
			2- M26- 4 ST3B	12 - M30- 4H ST3B																		
			3- M30- 2 ST3B	13 - M40- 2H ST3B																		
			4- M30- 4 ST3B	14 - M40- 4H ST3B																		
			5- M40- 2 ST3B	15 - M50- 2H ST3B																		
			6- M40- 4 ST3B	16 - M50- 4H ST3B																		
			7- M50- 2 ST3B	17 -																		
			8- M50- 4 ST3B	18 -																		
			9- M26- 2H ST3B	19 -																		
			10-M26- 4H ST3B	20 -																		
12	549245	Bague de fermeture Anillo de cierre Anello di chiusura	- Schlussring - Fastening ring	1	1	1	1					1	1	1	1							
13	5316	Joint d'étanchéité Junta de estanque Guarnizióne	- Dichtungsring - Seal	1	1	1	1					1	1	1	1							
14	1878	Joint d'étanchéité Junta de estanque Guarnizióne	- Dichtungsring - Seal	1	1	1	1					1	1	1	1							
15	58558	Vis H,M14-60-8.8-ZN8/C Tornillo Vite	- Schraube - Screw	1	1	1	1					1	1	1	1							
16	561269	Joint d'étanchéité Junta de estanque Guarnizióne	- Dichtungsring - Seal	2	2	2	2					2	2	2	2							
17	561268	Embout d vérin d'incli. Cabo de cilindro de inclinación Ghiera di cilindro inclinazione	- Gabelkopf der neigezylinder - Tilt ram end tube	1	1	1	1					1	1	1	1							
18	269	Graisseur Engrasador Ingrassatore	- Schmiernippel - Greaser	1	1	1	1					1	1	1	1							
19	42256	Rondelle W14 ZN Arandela Rondella	- Unterlegscheibe - Washer	1	1	1	1					1	1	1	1							
20	42324	Ecrou H ,M14 zingué Tuerca Dado	- Mutter - Nut	1	1	1	1					1	1	1	1							
21	192777	Capuchon Capuchón Cappuccio	- Kappe - Cap	1	1	1	1					1	1	1	1							

M

+

Catalogue : 647483

Rep Hinw Fig Item Rif	Numéro Teil-Nr Numero Part-Nr Part-Nr	Désignation Bezeichnung Descripcion Description Descrizione	Qte-Menge-Cant-Qty-Q.ta										10 CD 8038									
			1	2	3	4	5	6	7	8	9	10	11	12	13	14	15	16	17	18	19	20
3		HYDRAULIQUE (Vérin d'inclinaison) (Inclinaison standard 6°/12°) HYDRAULIK (Neigungszylinder)(St. neigung 6°/12°) HIDRAULICO (Cilindro de inclinación)(Inclinación estandard 6°/12°) HYDRAULIC (Tilting cylinder)(Standard tilting 6°/12°) IDRAULICO (Cilindro di inclinazione) (Inclinazione standard 6°/12°)	1- M26- 2 ST3B	11 - M30- 2H ST3B																		
			2- M26- 4 ST3B	12 - M30- 4H ST3B																		
			3- M30- 2 ST3B	13 - M40- 2H ST3B																		
			4- M30- 4 ST3B	14 - M40- 4H ST3B																		
			5- M40- 2 ST3B	15 - M50- 2H ST3B																		
			6- M40- 4 ST3B	16 - M50- 4H ST3B																		
			7- M50- 2 ST3B	17 -																		
			8- M50- 4 ST3B	18 -																		
			9- M26- 2H ST3B	19 -																		
			10-M26- 4H ST3B	20 -																		
22	548000	Pochette de joints Juego de juntas Kit guarnizióne	- Dichtungssatz - Seal kit	1	1	1	1					1	1	1	1							
23	169437	Joint d'étanchéité Junta de estanque Guarnizióne	- Dichtungsring - Seal	2	2	2	2					2	2	2	2							
24	588726	Embout de vérin Cabo de cilindro Ghiera di cilindro	- Zylinderkopf - Ram end tube	1	1	1	1					1	1	1	1							
25	588727	Ecrou Tuerca Dado	- Mutter - Nut	1	1	1	1					1	1	1	1							
26	562137	Tige de vérin Vástago de cilindro Stelo del cilindro	- Zylinder stange - Cylinder rod	1	1	1	1					1	1	1	1							

M

10 CE 8039

HYDRAULIQUE (Vérin de direction)
HYDRAULIK (Lenkungszylinder)
HIDRAULICO (Cilindro de dirección)
HYDRAULIC (Steering cylinder)
IDRAULICO (cilindro di sterzo)

M 40-2 ST3B
M 50-2 ST3B

M 40-2H ST3B
M 50-2H ST3B

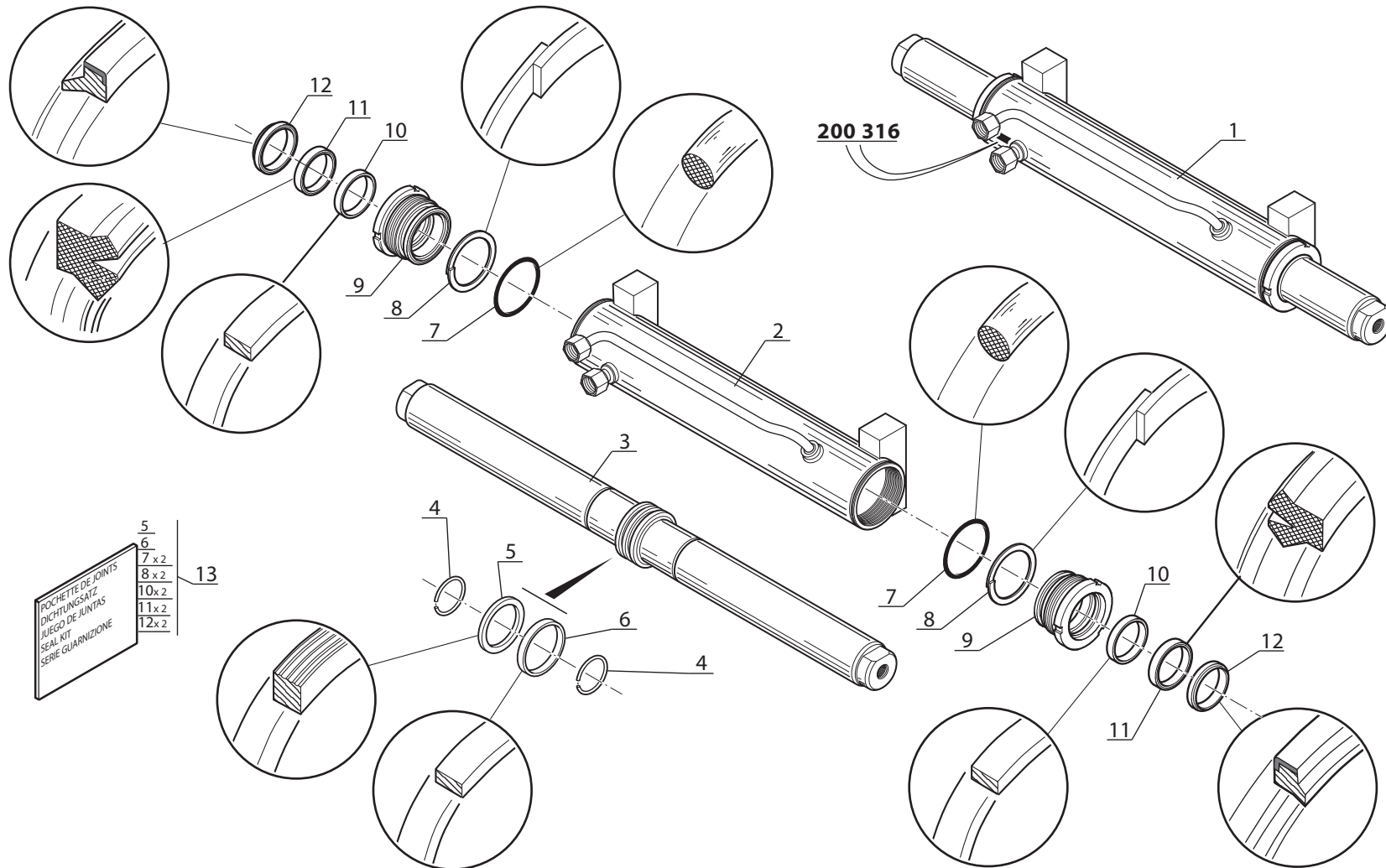
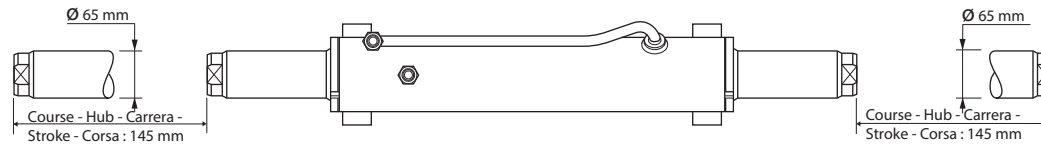

10 CE 8040

HYDRAULIQUE (Vérin de direction)
HYDRAULIK (Lenkungszylinder)
HIDRAULICO (Cilindro de dirección)
HYDRAULIC (Steering cylinder)
IDRAULICO (cilindro di sterzo)

M 26-2 ST3B
M 30-2 ST3B

M 26-2H ST3B
M 30-2H ST3B

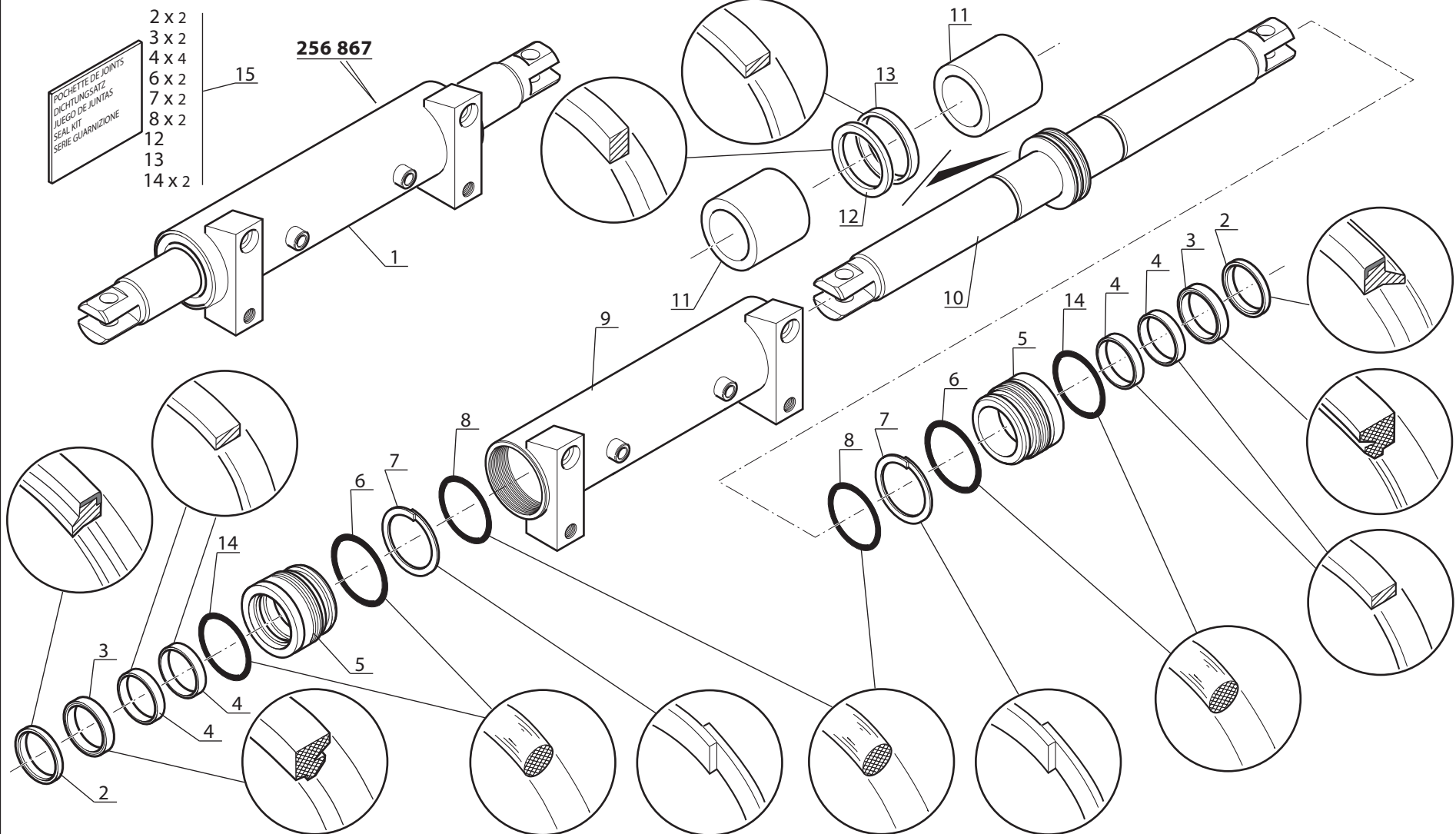
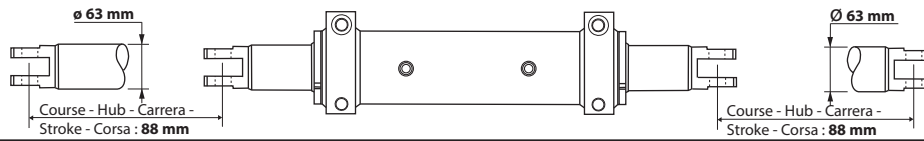

Catalogue : 647483

Rep Hinw Fig Item Rif	Numéro Teil-Nr Numero Part-Nr Part-Nr	Désignation Bezeichnung Descripcion Description Descrizione	Qte-Menge-Cant-Qty-Q.ta										10 CE 8040									
			1- M26- 2 ST3B 2- M26- 4 ST3B 3- M30- 2 ST3B 4- M30- 4 ST3B 5- M40- 2 ST3B 6- M40- 4 ST3B 7- M50- 2 ST3B 8- M50- 4 ST3B 9- M26- 2H ST3B 10-M26- 4H ST3B										11 - M30- 2H ST3B 12 - M30- 4H ST3B 13 - M40- 2H ST3B 14 - M40- 4H ST3B 15 - M50- 2H ST3B 16 - M50- 4H ST3B 17 - 18 - 19 - 20 -									
			1	2	3	4	5	6	7	8	9	10	11	12	13	14	15	16	17	18	19	20
1	256867	Vérin Cilindro Cilindro - Zylinder - Cylinder	1		1						1		1									
2	748066	Joint d'étanchéité Junta de estanquei. Guarnizione di tenuta - Dichtring - Seal	2		2						2		2									
3	731388	Joint d'étanchéité Junta de estanquei. Guarnizione di tenuta - Dichtring - Seal	2		2						2		2									
4	604119	Joint d'étanchéité Junta de estanquei. Guarnizione di tenuta - Dichtungsring - Seal	4		4						4		4									
5	748064	Bague de fermeture Anillo de cierre Anello di chiusura - Schlussring - Fastening ring	2		2						2		2									
6	746068	Joint torique Junta tórica Anello OR - "O" ring - "O" ring	2		2						2		2									
7	182283	Joint anti-extrusion Junta antiextrusión Guarnizione - Abstützdichtung - Anti-extrusion seal	2		2						2		2									
8	703170	Joint torique Junta tórica Anello OR - "O" ring - "O" ring	2		2						2		2									
9	748063	Corps de vérin Cuerpo de cilindro Corpo di cilindro - Zylinder körper - Cylinder body	1		1						1		1									
10	748067	Tige de vérin Vástago de cilindro Stelo del cilindro - Zylinderstange - Cylinder rod	1		1						1		1									
11	748068	Entretoise Separador Distanziale - Querstrebe - Spacer	2		2						2		2									

+

M

Catalogue : 647483

2	HYDRAULIQUE (Vérin d'direction) HYDRAULIK (Lenkungszylinder) HIDRAULICO (Cilindro de direccion) HYDRAULIC (Steering cylinder) IDRAULICO (Cilindro di sterzo)			Qte-Menge-Cant-Qty-Q.ta										10 CE 8040									
	Rep Hinw Fig Item Rif	Numéro Teil-Nr Numero Part-Nr Part-Nr	Désignation Bezeichnung Descripcion Description Descrizione	1	2	3	4	5	6	7	8	9	10	11	12	13	14	15	16	17	18	19	20
12	561606	Joint d'étanchéité Junta de estanquei. Guarnizióne	- Dichtungsring - Seal	1		1						1		1									
13	561605	Joint d'étanchéité Junta de estanquei. Guarnizióne	- Dichtungsring - Seal	1		1						1		1									
14	748065	Joint Junta Guarnizióne	- Dichtung - Seal	2		2						2		2									
15	748069	Pochette de joints Juego de juntas Kit guarnizióni	- Dichtungssatz - Seal kit	1		1						1		1									

M

10 DA 8041

A PARTIR DE LA MACHINE
AB DER MASCHINE
A PARTIR DE LA MAQUINA
FROM MACHINE
A PARTIR DA MACCHINA

↳ N°: 796 282

DISTRIBUTEUR
KOMMANDOSTEUERVENTIL
DISTRIBUIDOR
VALVE BANK
DISTRIBUTORE

M 26-2/4 ST3B	M 26-2/4H ST3B
M 30-2/4 ST3B	M 30-2/4H ST3B
M 40-2/4 ST3B	M 40-2/4H ST3B
M 50-2/4 ST3B	M 50-2/4H ST3B

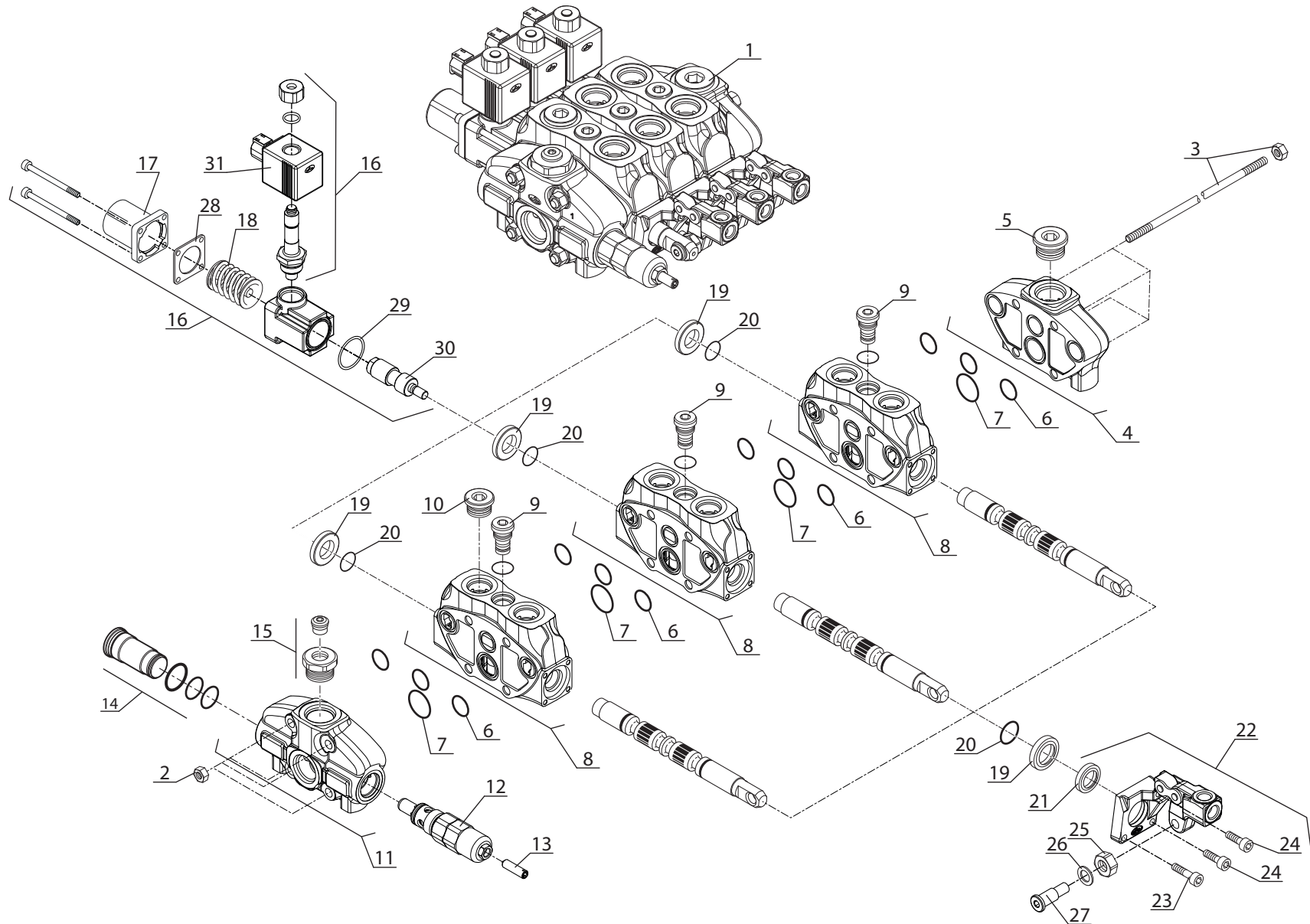

Catalogue : 647483

Rep Hinw Fig Item Rif	Numéro Teil-Nr Numero Part-Nr Part-Nr	Désignation Bezeichnung Descripcion Description Descrizione	Qte-Menge-Cant-Qty-Q.ta										10 DA 8041									
			1- M26- 2 ST3B 2- M26- 4 ST3B 3- M30- 2 ST3B 4- M30- 4 ST3B 5- M40- 2 ST3B 6- M40- 4 ST3B 7- M50- 2 ST3B 8- M50- 4 ST3B 9- M26- 2H ST3B 10-M26- 4H ST3B										11 - M30- 2H ST3B 12 - M30- 4H ST3B 13 - M40- 2H ST3B 14 - M40- 4H ST3B 15 - M50- 2H ST3B 16 - M50- 4H ST3B 17 - 18 - 19 - 20 -									
			1	2	3	4	5	6	7	8	9	10	11	12	13	14	15	16	17	18	19	20
1	311246	Distributeur Distribuidor Distributore - Kommandosteuerventil - Valve bank	1	1	1	1	1	1	1	1	1	1	1	1	1	1						
2	551359	Ecrou Tuerca Dado - Mutter - Nut	4	4	4	4	4	4	4	4	4	4	4	4	4	4						
3	798005	Jeux de tirants Juego de tirantes Gruppo tiranti - Spannstangensatz - Kit of tie rod	4	4	4	4	4	4	4	4	4	4	4	4	4	4						
4	702787	Elément d'entrée Elemento de entrada Elemento entrata - Eingangelement - Inlet member	1	1	1	1	1	1	1	1	1	1	1	1	1	1						
5	175744	Bouchon Tapón Tappo - Stopfen - Plug	1	1	1	1	1	1	1	1	1	1	1	1	1	1						
6	474734	Joint torique Junta tórica Anello OR - "O" ring - "O" ring	X	X	X	X	X	X	X	X	X	X	X	X	X	X						
7	551361	Joint torique Junta tórica Anello OR - "O" ring - "O" ring	X	X	X	X	X	X	X	X	X	X	X	X	X	X						
8	798004	Elément double effet Elemento doble efecto Elemanto doppio effetto - Doppeltwirkendelement - Double-acting member	3	3	3	3	3	3	3	3	3	3	3	3	3	3						
9	702794	Bouchon Tapón Tappo - Stopfen - Plug	3	3	3	3	3	3	3	3	3	3	3	3	3	3						
10	175743	Bouchon Tapón Tappo - Stopfen - Plug	1	1	1	1	1	1	1	1	1	1	1	1	1	1						
11	798384	Elément d'entrée Elemento de entrada Elemanto entrata - Eingangelement - Inlet member	1	1	1	1	1	1	1	1	1	1	1	1	1	1						

+

Catalogue : 647483

2	DISTRIBUTEUR KOMMANDOSTEUERVENTIL DISTRIBUIDOR VALVE BANK DISTRIBUTORE		Qte-Menge-Cant-Qty-Q.ta										10 DA 8041										
	Rep Hinw Fig Item Rif	Número Teil-Nr Numero Part-Nr Part-Nr	Désignation Bezeichnung Descripcion Description Descrizione	1	2	3	4	5	6	7	8	9	10	11	12	13	14	15	16	17	18	19	20
12	474722	Limiteur de pression Reguladores de presión Limitatore di pressionei	- Druckbegrenzventil - Relief valve	1	1	1	1	1	1	1	1	1	1	1	1	1	1	1					
13	748058	Vis Hc, M 8- 30-8.8 Tornillo Vite	- Schraube - Screw	1	1	1	1	1	1	1	1	1	1	1	1	1	1	1					
14	563817	Bouchon Tapón Tappo	- Stopfen - Plug	1	1	1	1	1	1	1	1	1	1	1	1	1	1	1					
15	746225	Bouchon Tapón Tappo	- Stopfen - Plug	1	1	1	1	1	1	1	1	1	1	1	1	1	1	1					
16	798388	Commande de rappel par ressort Mando de llamada para resorte Gruppo comando per molla	- Rückfederantrieb - Spring return drive	3	3	3	3	3	3	3	3	3	3	3	3	3	3	3					
17	798329	Chapeau Tapadera Capello	- Deckel - Cap	3	3	3	3	3	3	3	3	3	3	3	3	3	3	3					
18	551371	Ressort Muelle Molla	- Feder - Spring	3	3	3	3	3	3	3	3	3	3	3	3	3	3	3					
19	551331	Bague anti-poussière Anillo antipolvo Anello raschiapolvere	- Anti-staubbüchse - Dust excluder	6	6	6	6	6	6	6	6	6	6	6	6	6	6	6					
20	563819	Joint torique Junta tórica Anello OR	- "O" ring - "O" ring	6	6	6	6	6	6	6	6	6	6	6	6	6	6	6					
21	551362	Bague anti-poussière Anillo antipolvo Anello raschiapolvere	- Anti-staubbüchse - Dust excluder	3	3	3	3	3	3	3	3	3	3	3	3	3	3	3					
22	798009	Commande distributeur Mando distribuidor Comando distributore	- Ventilsteuerung - Valve bank drive	3	3	3	3	3	3	3	3	3	3	3	3	3	3	3					

M

+

Catalogue : 647483

3	DISTRIBUTEUR KOMMANDOSTEUERVENTIL DISTRIBUIDOR VALVE BANK DISTRIBUTORE			Qte-Menge-Cant-Qty-Q.ta										10 DA 8041									
	Rep Hinw Fig Item Rif	Número Teil-Nr Numero Part-Nr Part-Nr	Désignation Bezeichnung Descripcion Description Descrizione	1	2	3	4	5	6	7	8	9	10	11	12	13	14	15	16	17	18	19	20
23	794831	Vis CHC M5X25 Tornillo Vite	- Schraube - Screw	3	3	3	3	3	3	3	3	3	3	3	3	3	3	3	3				
24	474720	Vis CHC M5X18 Tornillo Vite	- Schraube - Screw	6	6	6	6	6	6	6	6	6	6	6	6	6	6	6	6				
25	551358	Ecrou Tuerca Dado	- Mutter - Nut	3	3	3	3	3	3	3	3	3	3	3	3	3	3	3	3				
26	798007	Rondelle Arandela Rondella	- Unterlegscheibe - Washer	3	3	3	3	3	3	3	3	3	3	3	3	3	3	3	3				
27	798006	Axe Eje Perno	- Bolzen - Pin	3	3	3	3	3	3	3	3	3	3	3	3	3	3	3	3				
28	750089	Joint plat Junta plana Guarnizióne	- Dichtung - Gasket	3	3	3	3	3	3	3	3	3	3	3	3	3	3	3	3				
29	798333	Joint Junta Guarnizióne	- Dichtung - Seal	3	3	3	3	3	3	3	3	3	3	3	3	3	3	3	3				
30	798331	Vis de réglage Tornillo de regul. Vite di regolaggio	- Stellschraube - Adjusting screw	3	3	3	3	3	3	3	3	3	3	3	3	3	3	3	3				
31	797943	Solénoïde Solenoid Solenoid	- Solenoid - Solenoid	3	3	3	3	3	3	3	3	3	3	3	3	3	3	3	3				

M

10 EA 8042

HYDRAULIQUE (Détails)
HYDRAULIK (Einzelteile)
HIDRAULICO (Detalles)
HYDRAULIC (Details)
IDRAULICO (Dettaglio)

M 26-2/4 ST3B	M 26-2/4H ST3B
M 30-2/4 ST3B	M 30-2/4H ST3B
M 40-2/4 ST3B	M 40-2/4H ST3B
M 50-2/4 ST3B	M 50-2/4H ST3B

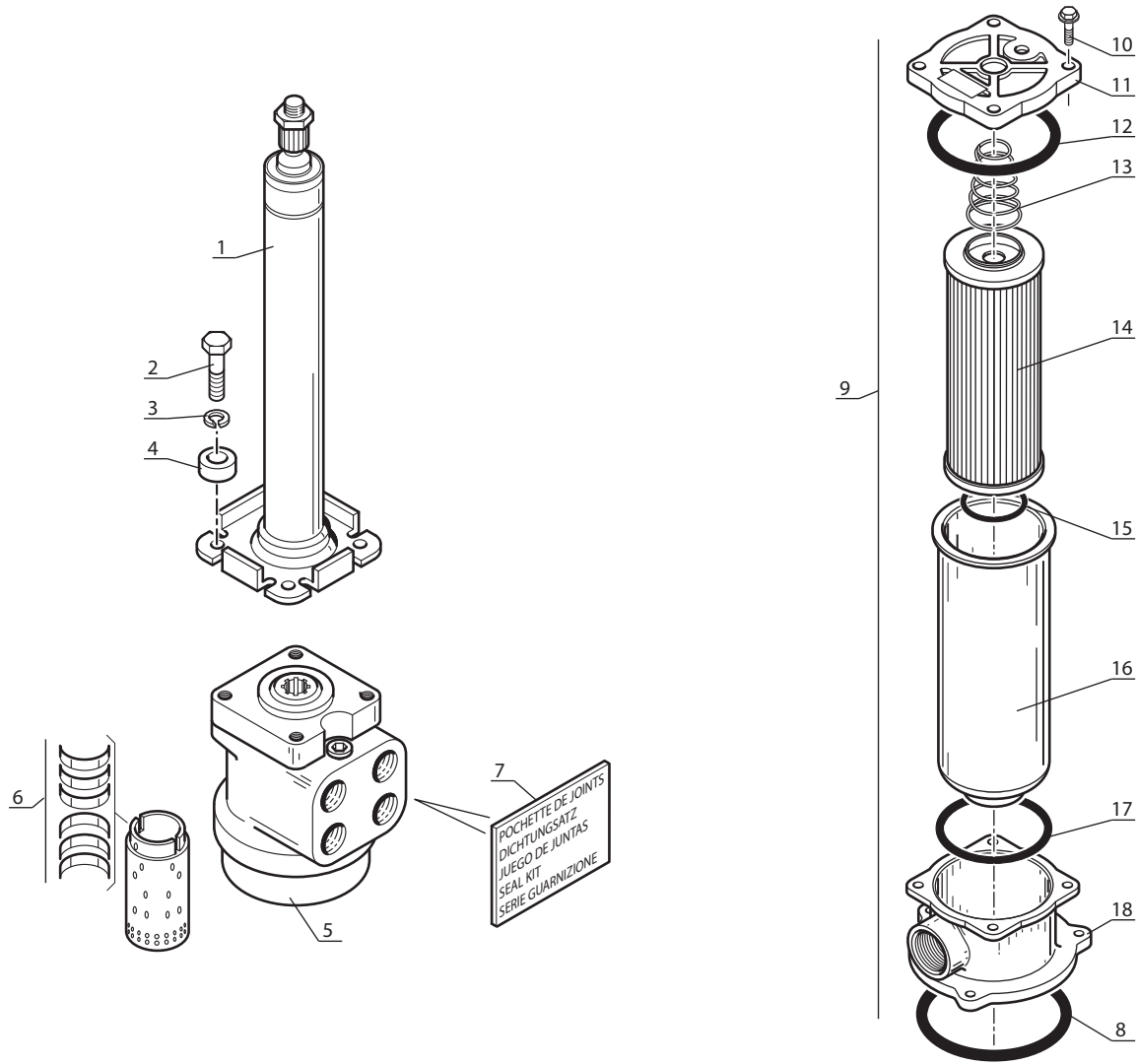

Catalogue : 647483

1	HYDRAULIQUE (Détails) HYDRAULIK (Einzelteile) HIDRAULICO (Detalles) HYDRAULIC (Details) IDRAULICO (Dettaglio)			Qte-Menge-Cant-Qty-Q.ta										10 EA 8042									
	Rep Hinw Fig Item Rif	Numéro Teil-Nr Numero Part-Nr Part-Nr	Désignation Bezeichnung Descripcion Description Descrizione	1- M26- 2 ST3B 2- M26- 4 ST3B 3- M30- 2 ST3B 4- M30- 4 ST3B 5- M40- 2 ST3B 6- M40- 4 ST3B 7- M50- 2 ST3B 8- M50- 4 ST3B 9- M26- 2H ST3B 10-M26- 4H ST3B										11 - M30- 2H ST3B 12 - M30- 4H ST3B 13 - M40- 2H ST3B 14 - M40- 4H ST3B 15 - M50- 2H ST3B 16 - M50- 4H ST3B 17 - 18 - 19 - 20 -									
				1	2	3	4	5	6	7	8	9	10	11	12	13	14	15	16	17	18	19	20
1	286875	Colonne de direction Columna de direcci. Colonna sterzo	- Lenksäule - Steering column	1	1	1	1	1	1	1	1	1	1	1	1	1	1						
2	63545	Vis H,M10-35-8.8-ZN8/C Tornillo Vite	- Schraube - Screw	4	4	4	4	4	4	4	4	4	4	4	4	4	4						
3	42232	Rondelle W10 ZN Arandela Rondella	- Unterlegscheibe - Washer	4	4	4	4	4	4	4	4	4	4	4	4	4	4						
4	251784	Rondelle SP11x20x12 Arandela Rondella	- Unterlegscheibe - Washer	4	4	4	4	4	4	4	4	4	4	4	4	4	4						
5	205960	Corps d pompe d direc. Cuerpo de bomba de direcció Corpo di pompa di sterzo	- Lenkung pompe körper - Steering pump body	1	1	1	1	1	1	1	1	1	1	1	1	1	1						
6	169586	Jeux de lamelles Juego de láminas Kit di lamella	- Lamelle satz - Lamella kit	1	1	1	1	1	1	1	1	1	1	1	1	1	1						
7	25026	Pochette de joints Juego de juntas Serie guarnizione	- Dichtungssatz - Seal kit	1	1	1	1	1	1	1	1	1	1	1	1	1	1						
8	562093	Joint d'étanchéité Junta de estanquei. Guarnizione	- Dichtungsring Seal	1	1	1	1	1	1	1	1	1	1	1	1	1	1						
9	221172	Filtre à huile hydraulique complet Filtro aceite hidraulico completo Filtro olio hidraulico completo	- Kompletter hydraulik ölfil. - Complete hydraulic oil fil.	1	1	1	1	1	1	1	1	1	1	1	1	1	1						
10	562461	Vis Tornillo Vite	- Schraube - Screw	4	4	4	4	4	4	4	4	4	4	4	4	4	4						
11	562086	Couvercle Tapadera Coperchio	- Deckel - Cover	1	1	1	1	1	1	1	1	1	1	1	1	1	1						

M

+

Catalogue : 647483

2	HYDRAULIQUE (Détails) HYDRAULIK (Einzelteile) HIDRAULICO (Detalles) HYDRAULIC (Details) IDRAULICO (Dettaglio)			Qte-Menge-Cant-Qty-Q.ta										10 EA 8042									
	Rep Hinw Fig Item Rif	Numéro Teil-Nr Numero Part-Nr Part-Nr	Désignation Bezeichnung Descripcion Description Descrizione	1- M26- 2 ST3B 2- M26- 4 ST3B 3- M30- 2 ST3B 4- M30- 4 ST3B 5- M40- 2 ST3B 6- M40- 4 ST3B 7- M50- 2 ST3B 8- M50- 4 ST3B 9- M26- 2H ST3B 10-M26- 4H ST3B										11 - M30- 2H ST3B 12 - M30- 4H ST3B 13 - M40- 2H ST3B 14 - M40- 4H ST3B 15 - M50- 2H ST3B 16 - M50- 4H ST3B 17 - 18 - 19 - 20 -									
				1	2	3	4	5	6	7	8	9	10	11	12	13	14	15	16	17	18	19	20
12	48384	Joint torique Junta tórica Anello OR	- "0" ring - "0" ring	1	1	1	1	1	1	1	1	1	1	1	1	1	1	1	1	1			
13	562088	Ressort Muelle Molla	- Feder - Spring	1	1	1	1	1	1	1	1	1	1	1	1	1	1	1	1	1			
14	221174	Cartouche fil. à huile ret. hydr. Cartucho filt. aceite ret. hidra. Cartuccia filtro olio ritorno idra.	- Patrone hydr ruckgang olfil - Cart. hydr. ret. oil filter	1	1	1	1	1	1	1	1	1	1	1	1	1	1	1	1	1			
15	562092	Joint torique Junta tórica Anello OR	- "0" ring - "0" ring	1	1	1	1	1	1	1	1	1	1	1	1	1	1	1	1	1			
16	562095	Jupe du filtre Faldón de filtro Manicotto	- Einfassung -Skirt	1	1	1	1	1	1	1	1	1	1	1	1	1	1	1	1	1			
17	562090	Joint Junta Guarnizióne	- Dichtung - Seal	1	1	1	1	1	1	1	1	1	1	1	1	1	1	1	1	1			
18	562089	Corps du filtre à huile Cuerpo de filtro de aceite Corpo filtro olio	- Ol filter körper - Oil filter body	1	1	1	1	1	1	1	1	1	1	1	1	1	1	1	1	1			

M

11 AA 8043

CIRCUIT ELECTRIQUE
STROMKREIS
CIRCUITO ELECTRICO
ELECTRIC CIRCUIT
IMPIANTO ELETTRICO

M 26-2/4 ST3B
M 30-2/4 ST3B

M 26-2/4H ST3B
M 30-2/4H ST3B

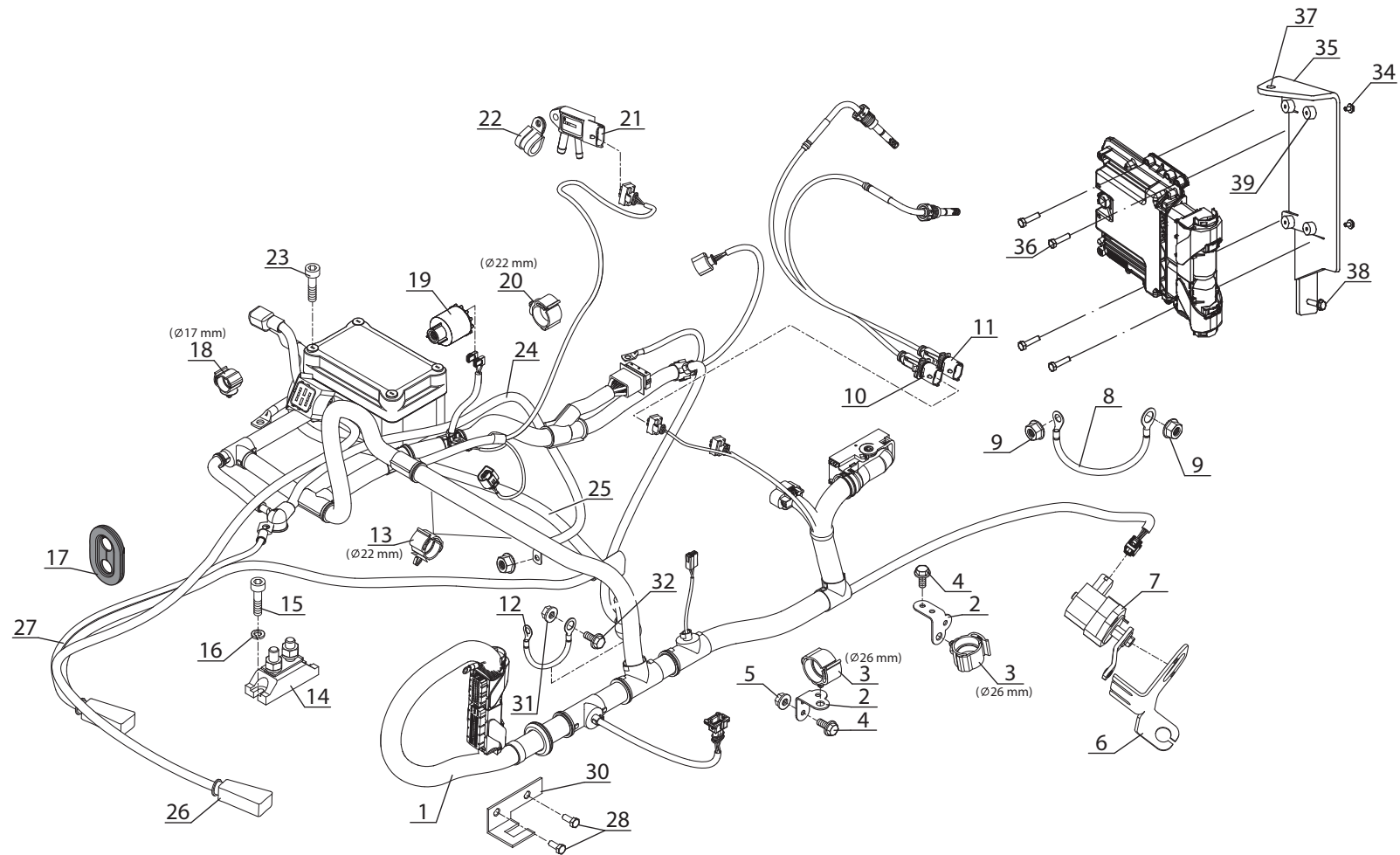

Catalogue : 647483

3	CIRCUIT ELECTRIQUE STROMKREIS CIRCUITO ELECTRICO ELECTRIC CIRCUIT IMPIANTO ELETRICO			Qte-Menge-Cant-Qty-Q.ta										11 AA 8043										
	Rep Hinw Fig Item Rif	Numéro Teil-Nr Numero Part-Nr Part-Nr	Désignation Bezeichnung Descripcion Description Descrizione	Beschrijving Kuvaus	1	2	3	4	5	6	7	8	9	10	11	12	13	14	15	16	17	18	19	20
22	194492	Collier Abrazadera Fascetta	- Spannschelle - Clamp		1	1	1	1					1	1	1	1								
23	268037	Vis CHc,M 4-16-8.8-ZN5/C Tornillo Vite	- Schraube - Screw		4	4	4	4					4	4	4	4								
24	301467	Câble 25 mm² Ø10/8 Lg 800 Cable Cavo	- Kabel - Cable		1	1	1	1					1	1	1	1								
25	312097	Câble 70/35 mm2 Lg 1000/210 Cable Cavo	- Kabel - Cable		1	1	1	1					1	1	1	1								
26	312095	Câble batterie-70 mm2 Lg 1500 Cable Cavo	- Kabel - Cable		1	1	1	1					1	1	1	1								
27	301464	Câble batterie+70/25 mm2Lg1600/700 Cable Cavo	- Kabel - Cable		1	1	1	1					1	1	1	1								
28	259946	Vis H EMBM8-168.8DIN6921 Tornillo Vite	- Schraube - Screw		2	2	2	2					2	2	2	2								
30	312561	Support ECM Soporte Supporto	- Halter - Bracket		1	1	1	1					1	1	1	1								
31	42231	Rondelle W12 ZN Arandela Rondella	- Unterlegscheibe - Washer		1	1	1	1					1	1	1	1								
32	63546	Vis H,M12-20-8.8-ZN8/C Tornillo Vite	- Schraube - Screw		1	1	1	1					1	1	1	1								
33	170884	Capuchon Capuchón Cappuccio	- Kappe - Cap		1	1	1	1					1	1	1	1								

M

+

Catalogue : 647483

4	CIRCUIT ELECTRIQUE STROMKREIS CIRCUITO ELECTRICO ELECTRIC CIRCUIT IMPIANTO ELETRICO			Qte-Menge-Cant-Qty-Q.ta										11 AA 8043									
	Rep Hinw Fig Item Rif	Numéro Teil-Nr Numero Part-Nr Part-Nr	Désignation Bezeichnung Descripcion Description Descrizione	1	2	3	4	5	6	7	8	9	10	11	12	13	14	15	16	17	18	19	20
34	273436	Vis Tornillo Vite	- Schraube - Screw	4	4	4	4					4	4	4	4								
35	51300723	Support ECM Support Supporto	- Halter - Soporte	1	1	1	1					1	1	1	1								
36	232750	Vis Tornillo Vite	- Schraube - Screw	4	4	4	4					4	4	4	4								
37	260475	Collier Abrazadera Fascetta	- Spannschelle - Clamp	2	2	2	2					2	2	2	2								
38	286323	Vis Tornillo Vite	- Schraube - Screw	2	2	2	2					2	2	2	2								
39	315689	Isolateur Aislador Isolatore	- Isolator - Isolator	4	4	4	4					4	4	4	4								

M

11 AA 8044

CIRCUIT ELECTRIQUE
STROMKREIS
CIRCUITO ELECTRICO
ELECTRIC CIRCUIT
IMPIANTO ELETTRICO

M 40-2/4 ST3B
M 50-2/4 ST3B

M 40-2/4H ST3B
M 50-2/4H ST3B

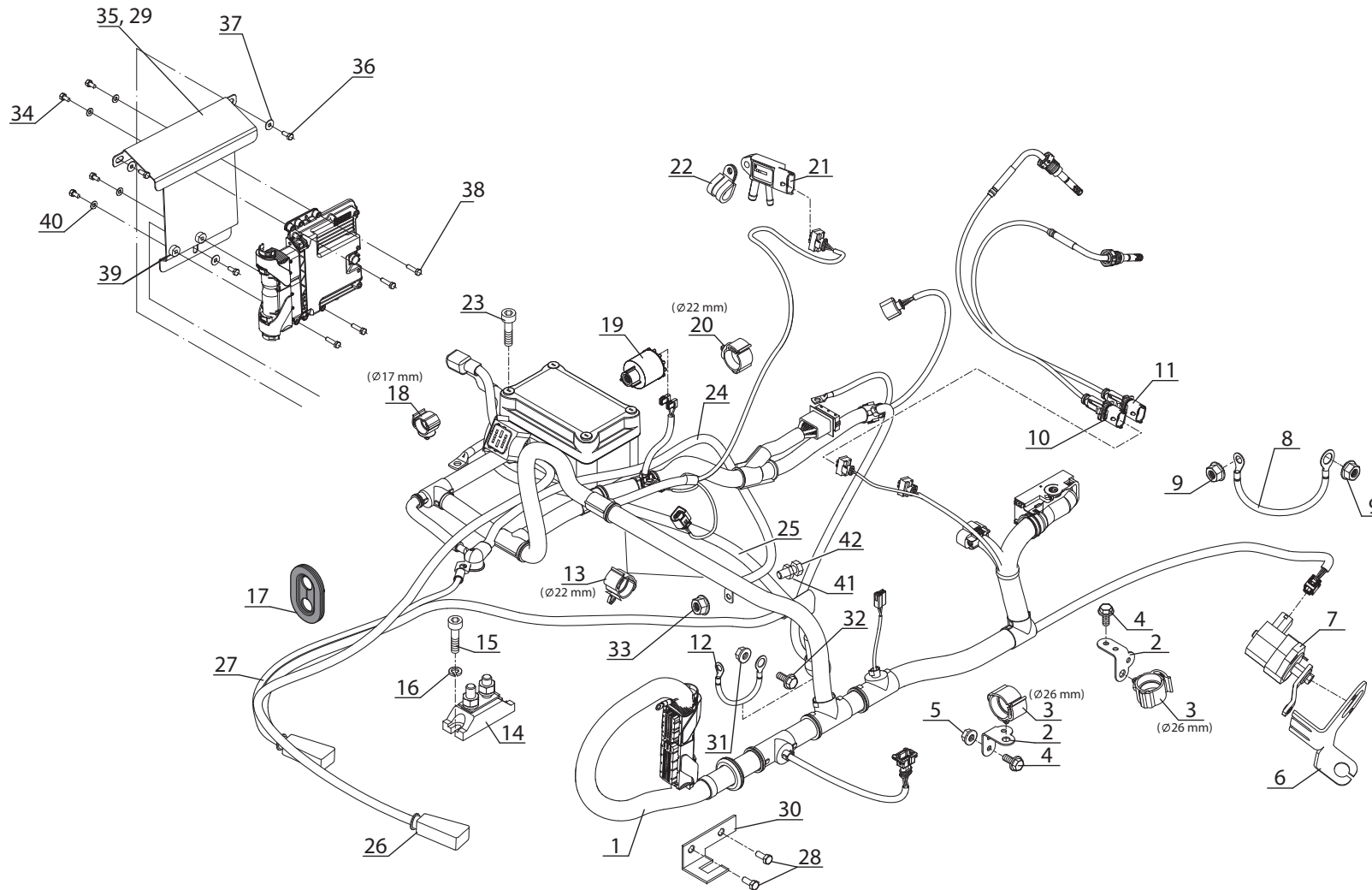

Catalogue : 647483

3	CIRCUIT ELECTRIQUE STROMKREIS CIRCUITO ELECTRICO ELECTRIC CIRCUIT IMPIANTO ELETRICO			Qte-Menge-Cant-Qty-Q.ta										11 AA 8044									
	Rep Hinw Fig Item Rif	Numéro Teil-Nr Numero Part-Nr Part-Nr	Désignation Bezeichnung Descripcion Description Descrizione	1	2	3	4	5	6	7	8	9	10	11	12	13	14	15	16	17	18	19	20
22	194492	Collier Abrazadera Fascetta	- Spanschelle - Clamp					1	1	1	1					1	1	1	1				
23	268037	Vis CHc,M4-16-8.8-ZN5/C Tornillo Vite	- Schraube - Screw					4	4	4	4					4	4	4	4				
24	301467	Câble 25mm²Ø10/8 Lg800 Cable Cavo	- Kabel - Cable					1	1	1	1					1	1	1	1				
25	312097	Câble 70/35mm2Lg1000/210 Cable Cavo	- Kabel - Cable					1	1	1	1					1	1	1	1				
26	312095	Câble batterie-70mm2Lg1500 Cable Cavo	- Kabel - Cable					1	1	1	1					1	1	1	1				
27	301464	Câble batterie+70/25mm2Lg1600/700 Cable Cavo	- Kabel - Cable					1	1	1	1					1	1	1	1				
28	259946	VisHEMB M8-168.8DIN6921 Tornillo Vite	- Schraube - Screw					2	2	2	2					2	2	2	2				
29	310006	Support ECM Soporte Supporto	- Halter - Bracket					1	1	1	1					1	1	1	1				
30	312561	Support Soporte Supporto	- Halter - Bracket					1	1	1	1					1	1	1	1				
31	42231	Rondelle W12 ZN Arandela Rondella	- Unterlegscheibe - Washer					1	1	1	1					1	1	1	1				
32	63546	Vis H,M12-20-8.8-ZN8/C Tornillo Vite	- Schraube - Screw					1	1	1	1					1	1	1	1				

M

+

Catalogue : 647483

4	CIRCUIT ELECTRIQUE STROMKREIS CIRCUITO ELECTRICO ELECTRIC CIRCUIT IMPIANTO ELETRICO			Qte-Menge-Cant-Qty-Q.ta										11 AA 8044									
	Rep Hinw Fig Item Rif	Número Teil-Nr Numero Part-Nr Part-Nr	Désignation Bezeichnung Descripcion Description Descrizione	1	2	3	4	5	6	7	8	9	10	11	12	13	14	15	16	17	18	19	20
33	170884	Capuchon Capuchón Cappuccio	- Kappe - Cap					1	1	1	1					1	1	1	1				
34	273436	Vis Tornillo Vite	- Schraube - Screw					4	4	4	4					4	4	4	4				
35	260475	Collier Abrazadera Fascetta	- Spannschelle - Clamp					2	2	2	2					2	2	2	2				
36	25713	Vis Tornillo Vite	- Schraube - Screw					9	9	9	9					9	9	9	9				
37	198138	Rondelle Arandela Rondella	- Unterlegscheibe - Washer					3	3	3	3					3	3	3	3				
38	278713	Vis Tornillo Vite	- Schraube - Screw					7	7	7	7					7	7	7	7				
39	315689	Isolateur Aislador Isolatore	- Isolator - Isolator					4	4	4	4					4	4	4	4				
40	306952	Rondelle Arandela Rondella	- Unterlegscheibe - Washer					4	4	4	4					4	4	4	4				
41	29437	Rondelle Washer Rondella	- Unterlegscheibe - Arandela					1	1	1	1					1	1	1	1				
42	63727	Vis Screw Vite	- Schraube - Tornillo					1	1	1	1					1	1	1	1				

M

11 AA 8045

CIRCUIT ELECTRIQUE
 STROMKREIS
 CIRCUITO ELETTRICO
 ELECTRIC CIRCUIT
 IMPIANTO ELETTRICO

M 26-2/4 ST3B	M 26-2/4H ST3B
M 30-2/4 ST3B	M 30-2/4H ST3B
M 40-2/4 ST3B	M 40-2/4H ST3B
M 50-2/4 ST3B	M 50-2/4H ST3B

JUSQU'A LA MACHINE
 BIS DER MASCHINE
 HASTA LA MAQUINA
 UP TO MACHINE
 FINO LA MACCHINA

● → N°: 796 281

A PARTIR DE LA MACHINE
 AB DER MASCHINE
 A PARTIR DE LA MAQUINA
 FROM MACHINE
 A PARTIR DA MACCHINA

○ → N°: 796 282

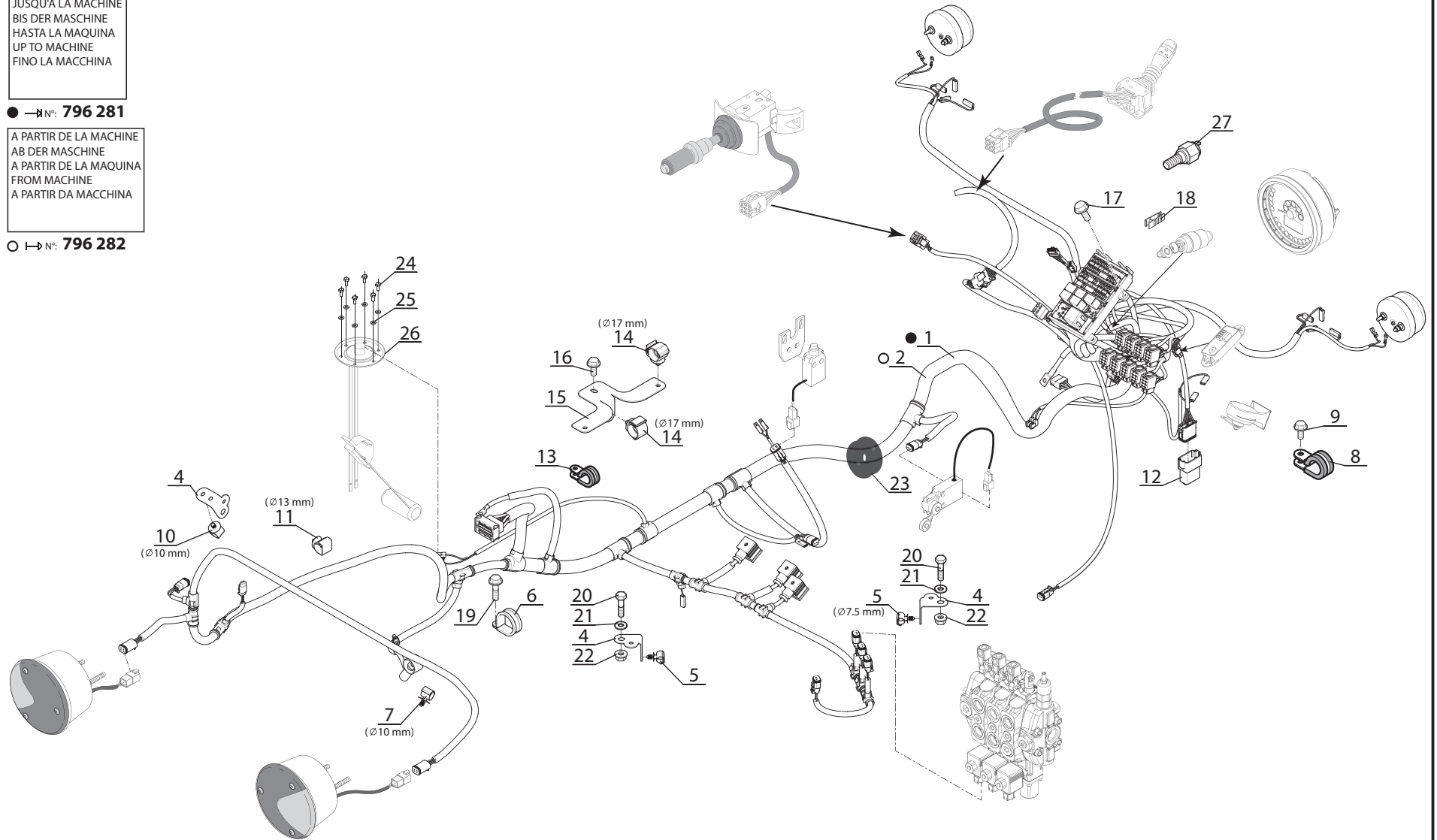

Catalogue : 647483

Rep Hinw Fig Item Rif	Numéro Teil-Nr Numero Part-Nr Part-Nr	Désignation Bezeichnung Descripcion Description Descrizione	Qte-Menge-Cant-Qty-Q.ta										11 AA 8045									
			1- M26- 2 ST3B 2- M26- 4 ST3B 3- M30- 2 ST3B 4- M30- 4 ST3B 5- M40- 2 ST3B 6- M40- 4 ST3B 7- M50- 2 ST3B 8- M50- 4 ST3B 9- M26- 2H ST3B 10-M26- 4H ST3B										11 - M30- 2H ST3B 12 - M30- 4H ST3B 13 - M40- 2H ST3B 14 - M40- 4H ST3B 15 - M50- 2H ST3B 16 - M50- 4H ST3B 17 - 18 - 19 - 20 -									
			1	2	3	4	5	6	7	8	9	10	11	12	13	14	15	16	17	18	19	20
1	51300633	Faisceau (Châssis) Haz (Bastidor) Fascio (Telaio)	- Kabelbaum (Gestell) - Wiring harness (Frame)	1	1	1	1	1	1	1	1	1	1	1	1	1	1	1	1	1		
2	311245	Faisceau (Châssis) Haz (Bastidor) Fascio (Telaio)	- Kabelbaum (Gestell) - Wiring harness (Frame)	1	1	1	1	1	1	1	1	1	1	1	1	1	1	1	1	1		
4	257779	Support collier Soporte abrazadera Supporto fascetta	- Klemmeträger - Clamp bracket	3	3	3	3	3	3	3	3	3	3	3	3	3	3	3	3	3		
5	260472	Collier Ø 7,5 Abrazadera Fascetta	- Spannschelle - Clamp	2	2	2	2	2	2	2	2	2	2	2	2	2	2	2	2	2		
6	273846	Collier Abrazadera Fascetta	- Spannschelle - Clamp	1	1	1	1	1	1	1	1	1	1	1	1	1	1	1	1	1		
7	260473	Collier Ø10 Abrazadera Fascetta	- Spannschelle - Clamp	1	1	1	1	1	1	1	1	1	1	1	1	1	1	1	1	1		
8	249209	Collier Abrazadera Fascetta	- Spannschelle - Clamp	1	1	1	1	1	1	1	1	1	1	1	1	1	1	1	1	1		
9	259946	Vis H EMB M 8-168.8DIN6921 Tornillo Vite	- Schraube - Screw	1	1	1	1	1	1	1	1	1	1	1	1	1	1	1	1	1		
10	260473	Collier Ø10 Abrazadera Fascetta	- Spannschelle - Clamp	2	2	2	2	2	2	2	2	2	2	2	2	2	2	2	2	2		
11	260474	Collier Ø13 Abrazadera Fascetta	- Spannschelle - Clamp	1	1	1	1	1	1	1	1	1	1	1	1	1	1	1	1	1		
12	220408	Shunt Shunt Shunt	- Nebenschluss - Shunt	1	1	1	1	1	1	1	1	1	1	1	1	1	1	1	1	1		

+

Catalogue : 647483

2	CIRCUIT ELECTRIQUE STROMKREIS CIRCUITO ELECTRICO ELECTRIC CIRCUIT IMPIANTO ELETRICO			Qte-Menge-Cant-Qty-Q.ta										11 AA 8045									
	Rep Hinw Fig Item Rif	Número Teil-Nr Numero Part-Nr Part-Nr	Désignation Bezeichnung Descripcion Description Descrizione	1	2	3	4	5	6	7	8	9	10	11	12	13	14	15	16	17	18	19	20
13	255587	Collier Abrazadera Fascetta	- Spawnschelle - Clamp	1	1	1	1	1	1	1	1	1	1	1	1	1	1	1	1				
14	260475	Collier Ø17 Abrazadera Fascetta	- Spawnschelle - Clamp	2	2	2	2	2	2	2	2	2	2	2	2	2	2	2	2				
15	307635	Patte de fixation Brida de fijación Flangia di fissaggio	- Befestigung auge - Fastening lug	1	1	1	1	1	1	1	1	1	1	1	1	1	1	1	1				
16	54951	Vis H EMB M6-16-8.8-ZN8/C Tornillo Vite	- Schraube - Screw	1	1	1	1	1	1	1	1	1	1	1	1	1	1	1	1				
17	232750	Vis H EMBM6-16-8.8-ZN8/C Tornillo Vite	- Schraube - Screw	1	1	1	1	1	1	1	1	1	1	1	1	1	1	1	1				
18	245295	Pince à fusible Pinza a fusible Pinza fusibili	- Lichtsicherung Kneifen - Fuse pincers	1	1	1	1	1	1	1	1	1	1	1	1	1	1	1	1				
19	259946	Vis H EMBM8-20 8.8DIN6921 Tornillo Vite	- Schraube - Screw	3	3	3	3	3	3	3	3	3	3	3	3	3	3	3	3				
20	57446	Vis H,M 8-25-8.8-ZN8/C Tornillo Vite	- Schraube - Screw	2	2	2	2	2	2	2	2	2	2	2	2	2	2	2	2				
21	61674	Rondelle M 8 ZN Arandela Rondella	- Unterlegscheibe - Washer	2	2	2	2	2	2	2	2	2	2	2	2	2	2	2	2				
22	254177	Ecrou H EMB M8C8ZN8/C Tuerca Dado	- Mutter - Nut	2	2	2	2	2	2	2	2	2	2	2	2	2	2	2	2				
23	82520	Passe-fil Arandela de gaucho Passo-filo	- Gummischeibe - Cable grommet	1	1	1	1	1	1	1	1	1	1	1	1	1	1	1	1				

M

+

11 CB 8046

ELECTRICITE (Détails)
 ELEKTIZITÄT (Einzelheiten)
 ELECTRICIDAD (Detalles)
 ELECTRICITY (Details)
 ELETTRICO (Dettaglio)

M 26-2/4 ST3B	M 26-2/4H ST3B
M 30-2/4 ST3B	M 30-2/4H ST3B
M 40-2/4 ST3B	M 40-2/4H ST3B
M 50-2/4 ST3B	M 50-2/4H ST3B

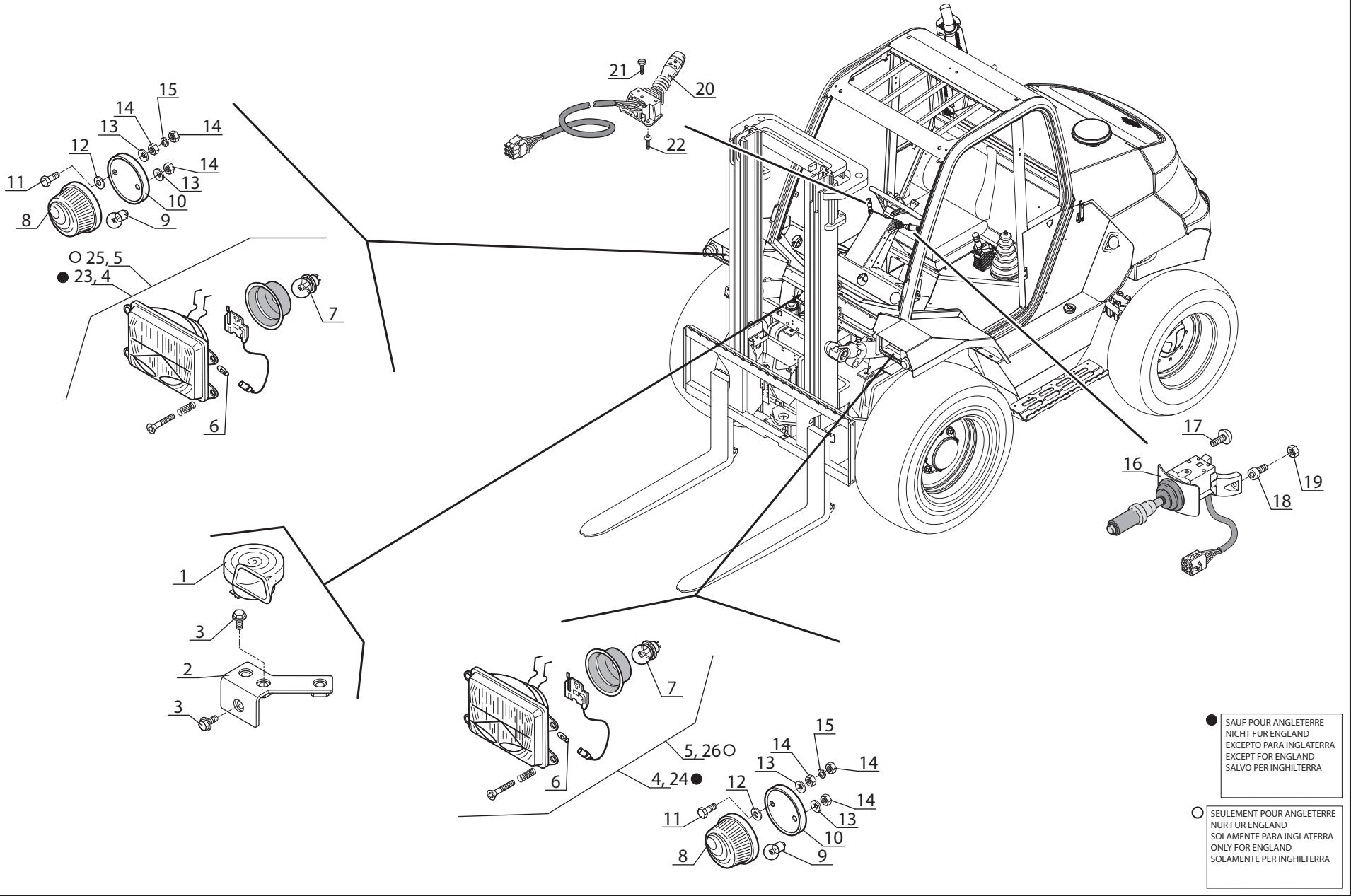

● SAUF POUR ANGLETERRE
 NICHT FÜR ENGLAND
 EXCEPTO PARA INGLATERRA
 SALVO PER INGHILTERRA

○ SEULEMENT POUR ANGLETERRE
 NUR FÜR ENGLAND
 SOLAMENTE PARA INGLATERRA
 ONLY FOR ENGLAND
 SOLAMENTE PER INGHILTERRA

Catalogue : 647483

1	ELECTRICITE (Détails) ELEKTIZITÄT (Einzelheiten) ELECTRICIDAD (Detalles) ELECTRICITY (Details) ELETRICO (Dettaglio)			Qte-Menge-Cant-Qty-Q.ta										11 CB 8046									
	Rep Hinw Fig Item Rif	Numéro Teil-Nr Numero Part-Nr Part-Nr	Désignation Bezeichnung Descripcion Description Descrizione	1- M26- 2 ST3B 2- M26- 4 ST3B 3- M30- 2 ST3B 4- M30- 4 ST3B 5- M40- 2 ST3B 6- M40- 4 ST3B 7- M50- 2 ST3B 8- M50- 4 ST3B 9- M26- 2H ST3B 10-M26- 4H ST3B										11 - M30- 2H ST3B 12 - M30- 4H ST3B 13 - M40- 2H ST3B 14 - M40- 4H ST3B 15 - M50- 2H ST3B 16 - M50- 4H ST3B 17 - 18 - 19 - 20 -									
				1	2	3	4	5	6	7	8	9	10	11	12	13	14	15	16	17	18	19	20
1	20125	Avertisseur Bocina Signalatore acustico	- Hüpe - Horn	1	1	1	1	1	1	1	1	1	1	1	1	1							
2	307736	Patte de fixation Brida de fijación Flangia di fissaggio	- Befestigung auge - Fastening lug	1	1	1	1	1	1	1	1	1	1	1	1	1							
3	259946	Vis H EMB M8-16 8.8DIN6921 Tornillo Vite	- Schraube - Screw	3	3	3	3	3	3	3	3	3	3	3	3	3							
4	*189007	Phare avant complet Faro delantero completo Faro di livaro anteriore completo	- Komplette vorn scheinwerfer - Complete front headlight	2	2	2	2	2	2	2	2	2	2	2	2	2							
5	*189008	Phare avant complet Faro delantero completo Faro di livaro anteriore completo	- Komplette vorn scheinwerfer - Complete front headlight	2	2	2	2	2	2	2	2	2	2	2	2	2							
6	32058	Ampoule (blanche) Bombilla (blanca) Lampadina (Bianca)	- Birne (weiss) - Bulb (white)	1	1	1	1	1	1	1	1	1	1	1	1	1							
7	20996	Ampoule (12 V -4 W) Bombilla Lampadina	- Birne - Bulb	1	1	1	1	1	1	1	1	1	1	1	1	1							
8	296524	Clignotant Intermittente Vetro	- Blinklichter - Direction lights	2	2	2	2	2	2	2	2	2	2	2	2	2							
9	675	Ampoule (12 V - 21W) Bombilla Lampadina	- Birne - Bulb	2	2	2	2	2	2	2	2	2	2	2	2	2							
10	296523	Platine clignotant Platina Piastra	- Anschluss - Delivery port conn.	2	2	2	2	2	2	2	2	2	2	2	2	2							

M

+

Catalogue : 647483

2	ELECTRICITE (Détails) ELEKTIZITÄT (Einzelheiten) ELECTRICIDAD (Detalles) ELECTRICITY (Details) ELETRICO (Dettaglio)			Qte-Menge-Cant-Qty-Q.ta										11 CB 8046									
	Rep Hinw Fig Item Rif	Número Teil-Nr Numero Part-Nr Part-Nr	Désignation Bezeichnung Descripcion Description Descrizione	1	2	3	4	5	6	7	8	9	10	11	12	13	14	15	16	17	18	19	20
11	54230	Vis H,M 5-20-8.8-ZN5/C Tornillo Vite	- Schraube - Screw	4	4	4	4	4	4	4	4	4	4	4	4	4	4	4	4				
12	28959	Rondelle M5 ZN Arandela Rondella	- Unterlegscheibe - Washer	2	2	2	2	2	2	2	2	2	2	2	2	2	2	2	2				
13	192310	Rondelle JZC5CAD.BICH Arandela Rondella	- Unterlegscheibe - Washer	4	4	4	4	4	4	4	4	4	4	4	4	4	4	4	4				
14	54232	Ecrou H ,M 5 ZN Tuerca Dado	- Mutter - Nut	6	6	6	6	6	6	6	6	6	6	6	6	6	6	6	6				
15	29483	Rondelle W 5 ZN Arandela Rondella	- Unterlegscheibe - Washer	2	2	2	2	2	2	2	2	2	2	2	2	2	2	2	2				
16	234956	Inverseur de marche Inversor de marcha Invertitore di marcia	- Umsteuergetriebe - Reversing gears	1	1	1	1	1	1	1	1	1	1	1	1	1	1	1	1				
17	230853	Vis CBHc,M 5-8-10.9-ZN5/NOIR Tornillo Vite	- Schraube - Screw	2	2	2	2	2	2	2	2	2	2	2	2	2	2	2	2				
18	5323	Vis Tornillo Vite	- Schraube - Screw	2	2	2	2	2	2	2	2	2	2	2	2	2	2	2	2				
19	54232	Ecrou H ,M5 ZN Tuerca Dado	- Mutter - Nut	8	8	8	8	8	8	8	8	8	8	8	8	8	8	8	8				
20	191384	Comm. d'éclairage Conmutador de luces Comm. di illumina.	- Beleuchtungschalter - Lighting switch	1	1	1	1	1	1	1	1	1	1	1	1	1	1	1	1				
21	184036	Vis CBHc,M 5-16-10.9-ZN5/NOIR Tornillo Vite	- Schraube - Screw	14	14	14	14	14	14	14	14	14	14	14	14	14	14	14	14				

M

+

11 CB 8047

ELECTRICITE (Détails)
ELEKTIZITÄT (Einzelheiten)
ELECTRICIDAD (Detalles)
ELECTRICITY (Details)
ELETTRICO (Dettaglio)

M 26-2/4 ST3B	M 26-2/4H ST3B
M 30-2/4 ST3B	M 30-2/4H ST3B
M 40-2/4 ST3B	M 40-2/4H ST3B
M 50-2/4 ST3B	M 50-2/4H ST3B

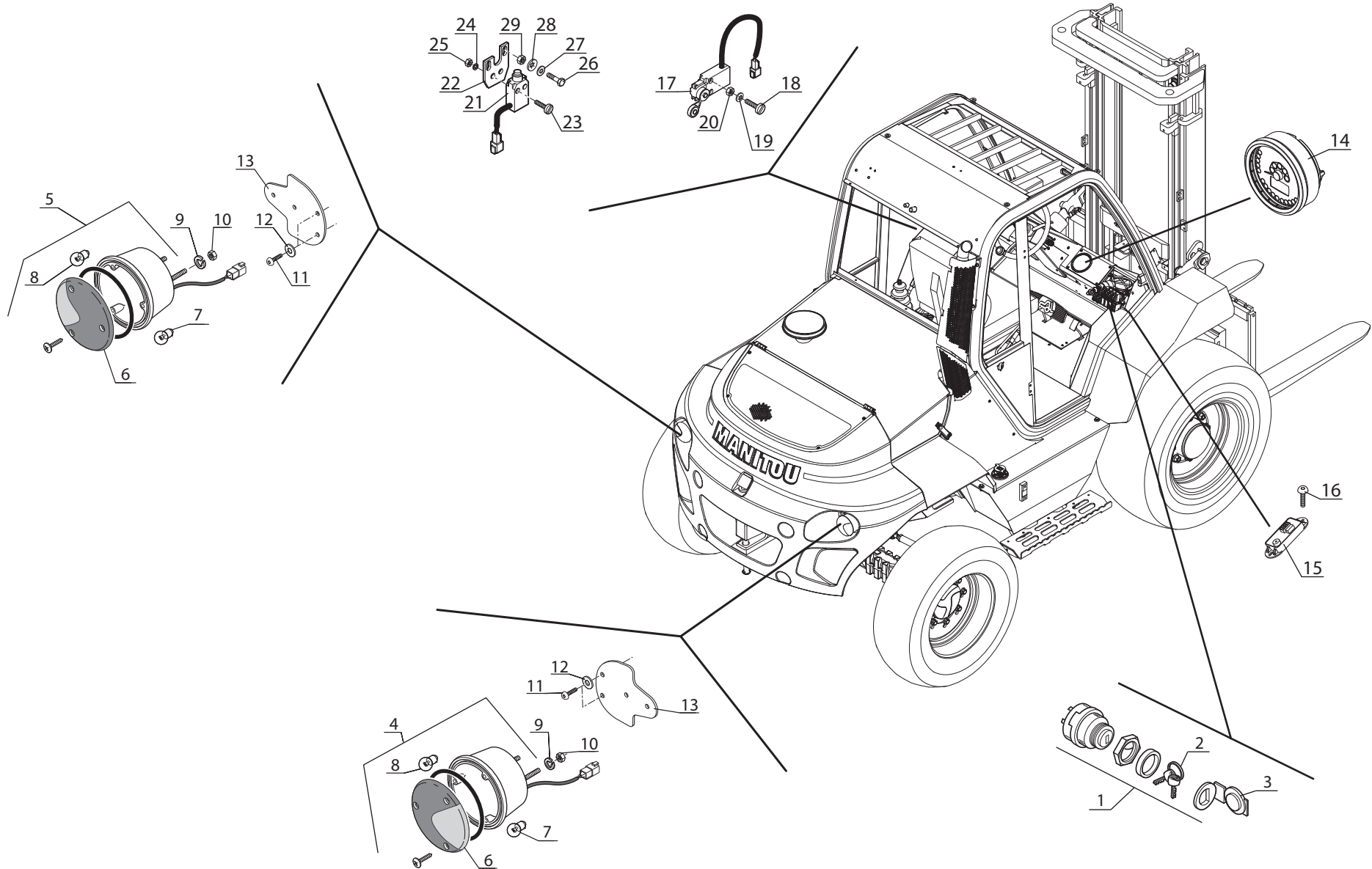

Catalogue : 647483

1	ELECTRICITE (Détails) ELEKTIZITÄT (Einzelheiten) ELECTRICIDAD (Detalles) ELECTRICITY (Details) ELETRICO (Dettaglio)			Qte-Menge-Cant-Qty-Q.ta										11 CB 8047									
	Rep Hinw Fig Item Rif	Numéro Teil-Nr Numero Part-Nr Part-Nr	Désignation Bezeichnung Descripcion Description Descrizione	1- M26- 2 ST3B 2- M26- 4 ST3B 3- M30- 2 ST3B 4- M30- 4 ST3B 5- M40- 2 ST3B 6- M40- 4 ST3B 7- M50- 2 ST3B 8- M50- 4 ST3B 9- M26- 2H ST3B 10-M26- 4H ST3B										11 - M30- 2H ST3B 12 - M30- 4H ST3B 13 - M40- 2H ST3B 14 - M40- 4H ST3B 15 - M50- 2H ST3B 16 - M50- 4H ST3B 17 - 18 - 19 - 20 -									
				1	2	3	4	5	6	7	8	9	10	11	12	13	14	15	16	17	18	19	20
1	184817	Contacteur à clé Contactor a llave Interruttore chiaven	- Zündschalter - Ignition switch	1	1	1	1	1	1	1	1	1	1	1	1	1	1						
2	184818	Clé de contact Llave de contact Chiave	- Schlüssel - Key	1	1	1	1	1	1	1	1	1	1	1	1	1	1						
3	77522	Capuchon Capuchón Cappuccio	- Kappe - Cap	1	1	1	1	1	1	1	1	1	1	1	1	1	1						
4	234523	Feu arrière droit comp. Faro tras. der. comp. Fanale post. destro com.	- Komple. recht schlusslatern - Complete R.H. tail light	1	1	1	1	1	1	1	1	1	1	1	1	1	1						
5	234524	Feu arrière gauc. comp. Faro tras. izqui. comp. Fanale post. sin. comp.	- Komple. link schluslaterne - Complete L.H. tail light	1	1	1	1	1	1	1	1	1	1	1	1	1	1						
6	602005	Verre de feu arrière Vidrio de faro trasero Vetro di fanale posteriore	- Schlusslaterne glas - Tail light glass	1	1	1	1	1	1	1	1	1	1	1	1	1	1						
7	675	Ampoule (12 V-21W) Bombilla Lampadina	- Birne - Bulb	2	2	2	2	2	2	2	2	2	2	2	2	2	2						
8	31867	Ampoule (12V-21W-5W) Bombilla Lampadina	- Birne - Bulb	2	2	2	2	2	2	2	2	2	2	2	2	2	2						
9	42316	Rondelle W 6 ZN Arandela Rondella	- Unterlegscheibe - Washer	4	4	4	4	4	4	4	4	4	4	4	4	4	4						
10	25714	Ecrou H ,M 6 ZN Tuerca Dado	- Mutter - Nut	4	4	4	4	4	4	4	4	4	4	4	4	4	4						

M

+

Catalogue : 647483

2	ELECTRICITE (Détails) ELEKTIZITÄT (Einzelheiten) ELECTRICIDAD (Detalles) ELECTRICITY (Details) ELETRICO (Dettaglio)			Qte-Menge-Cant-Qty-Q.ta										11 CB 8047																													
	Rep Hinw Fig Item Rif	Numéro Teil-Nr Numero Part-Nr Part-Nr	Désignation Bezeichnung Descripcion Description Descrizione	<table border="0"> <tr> <td>1- M26- 2 ST3B</td><td>11 - M30- 2H ST3B</td> <td>2- M26- 4 ST3B</td><td>12 - M30- 4H ST3B</td> <td>3- M30- 2 ST3B</td><td>13 - M40- 2H ST3B</td> <td>4- M30- 4 ST3B</td><td>14 - M40- 4H ST3B</td> <td>5- M40- 2 ST3B</td><td>15 - M50- 2H ST3B</td> <td>6- M40- 4 ST3B</td><td>16 - M50- 4H ST3B</td> <td>7- M50- 2 ST3B</td><td>17 -</td> <td>8- M50- 4 ST3B</td><td>18 -</td> <td>9- M26- 2H ST3B</td><td>19 -</td> <td>10-M26- 4H ST3B</td><td>20 -</td> </tr> </table>																				1- M26- 2 ST3B	11 - M30- 2H ST3B	2- M26- 4 ST3B	12 - M30- 4H ST3B	3- M30- 2 ST3B	13 - M40- 2H ST3B	4- M30- 4 ST3B	14 - M40- 4H ST3B	5- M40- 2 ST3B	15 - M50- 2H ST3B	6- M40- 4 ST3B	16 - M50- 4H ST3B	7- M50- 2 ST3B	17 -	8- M50- 4 ST3B	18 -	9- M26- 2H ST3B	19 -	10-M26- 4H ST3B	20 -
				1- M26- 2 ST3B	11 - M30- 2H ST3B	2- M26- 4 ST3B	12 - M30- 4H ST3B	3- M30- 2 ST3B	13 - M40- 2H ST3B	4- M30- 4 ST3B	14 - M40- 4H ST3B	5- M40- 2 ST3B	15 - M50- 2H ST3B	6- M40- 4 ST3B	16 - M50- 4H ST3B	7- M50- 2 ST3B	17 -	8- M50- 4 ST3B	18 -	9- M26- 2H ST3B	19 -	10-M26- 4H ST3B	20 -																				
1	2	3	4	5	6	7	8	9	10	11	12	13	14	15	16	17	18	19	20																								
11	205275	Vis CBHc,M10-20zinguée Tornillo Vite	- Schraube - Screw	4	4	4	4	4	4	4	4	4	4	4	4	4	4	4	4	4																							
12	198138	Rondelle L 10 ZN Arandela Rondella	- Unterlegscheibe - Washer	4	4	4	4	4	4	4	4	4	4	4	4	4	4	4	4	4																							
13	247251	Support feu arrière Soporte faro tras. Supporto fanale post.	- Schlusslaterne träger - Tail light bracket	2	2	2	2	2	2	2	2	2	2	2	2	2	2	2	2	2																							
14	302050	Horamètre Horametro Tachimetro	- Stundenzähler - Hour recorder	1	1	1	1	1	1	1	1	1	1	1	1	1	1	1	1	1																							
15	287435	Module Módulo Modulo	- Modul - Module	1	1	1	1	1	1	1	1	1	1	1	1	1	1	1	1	1																							
16	79533	Vis CBHc,M 5-10-10.9-ZN5/NOIR Tornillo Vite	- Schraube - Screw	2	2	2	2	2	2	2	2	2	2	2	2	2	2	2	2	2																							
17	219100	Contact. coup. transm. Contactor corte transmisión Contatorre taglio trasmissione	- Getriebe trenn schalter - Transmission cut-off switch	1	1	1	1	1	1	1	1	1	1	1	1	1	1	1	1	1																							
18	802986	Vis CS,M 4-20 zinguée Tornillo Vite	- Schraube - Screw	2	2	2	2	2	2	2	2	2	2	2	2	2	2	2	2	2																							
19	78806	Rondelle JZC4CAD.BICH Arandela Rondella	- Unterlegscheibe - Washer	2	2	2	2	2	2	2	2	2	2	2	2	2	2	2	2	2																							
20	25758	Ecrou H,M4ZN Tuerca Dado	- Mutter - Nut	2	2	2	2	2	2	2	2	2	2	2	2	2	2	2	2	2																							

M

+

Catalogue : 647483

3	ELECTRICITE (Détails) ELEKTIZITÄT (Einzelheiten) ELECTRICIDAD (Detalles) ELECTRICITY (Details) ELETRICO (Dettaglio)			Qte-Menge-Cant-Qty-Q.ta										11 CB 8047									
	Rep Hinw Fig Item Rif	Numéro Teil-Nr Numero Part-Nr Part-Nr	Désignation Bezeichnung Descripcion Description Descrizione																				
				1	2	3	4	5	6	7	8	9	10	11	12	13	14	15	16	17	18	19	20
21	279810	Contact. frein à main Conta. fr. de mano Contattore freno a mano	- Handbremseschalter - Handbrake switch	1	1	1	1	1	1	1	1	1	1	1	1	1	1	1					
22	193643	Support contacteur Soporte contactor Supporto contattore	- Schalter träger - Switch bracket	1	1	1	1	1	1	1	1	1	1	1	1	1	1	1					
23	31120	Vis CS,M 4-20 zinguée Tornillo Vite	- Schraube - Screw	2	2	2	2	2	2	2	2	2	2	2	2	2	2	2					
24	28987	Rondelle W 4 ZN Arandela Rondella	- Unterlegscheibe - Washer	2	2	2	2	2	2	2	2	2	2	2	2	2	2	2					
25	25758	Ecrou H,M4ZN Tuerca Dado	- Mutter - Nut	2	2	2	2	2	2	2	2	2	2	2	2	2	2	2					
26	25713	Vis H,M 6-16-8.8-ZN5/C Tornillo Vite	- Schraube - Screw	1	1	1	1	1	1	1	1	1	1	1	1	1	1	1					
27	29469	Rondelle M 6 ZN Arandela Rondella	- Unterlegscheibe - Washer	1	1	1	1	1	1	1	1	1	1	1	1	1	1	1					
28	174132	Rondelle JZC6CAD.BICH Arandela Rondella	- Unterlegscheibe - Washer	1	1	1	1	1	1	1	1	1	1	1	1	1	1	1					
29	25714	Ecrou H ,M 6 ZN Tuerca Dado	- Mutter - Nut	1	1	1	1	1	1	1	1	1	1	1	1	1	1	1					

M

11 CC 8048

ELECTRICITE (Poste de conduite)
 ELEKTRIZITÄT (Fahrerstand)
 ELECTRICIDAD (Puesto del conductor)
 ELECTRICITY (Cab structure)
 ELETTRICO (Posto di pilotaggio)

M 26-2/4 ST3B **M 26-2/4H ST3B**
M 30-2/4 ST3B **M 30-2/4H ST3B**
M 40-2/4 ST3B **M 40-2/4H ST3B**
M 50-2/4 ST3B **M 50-2/4H ST3B**

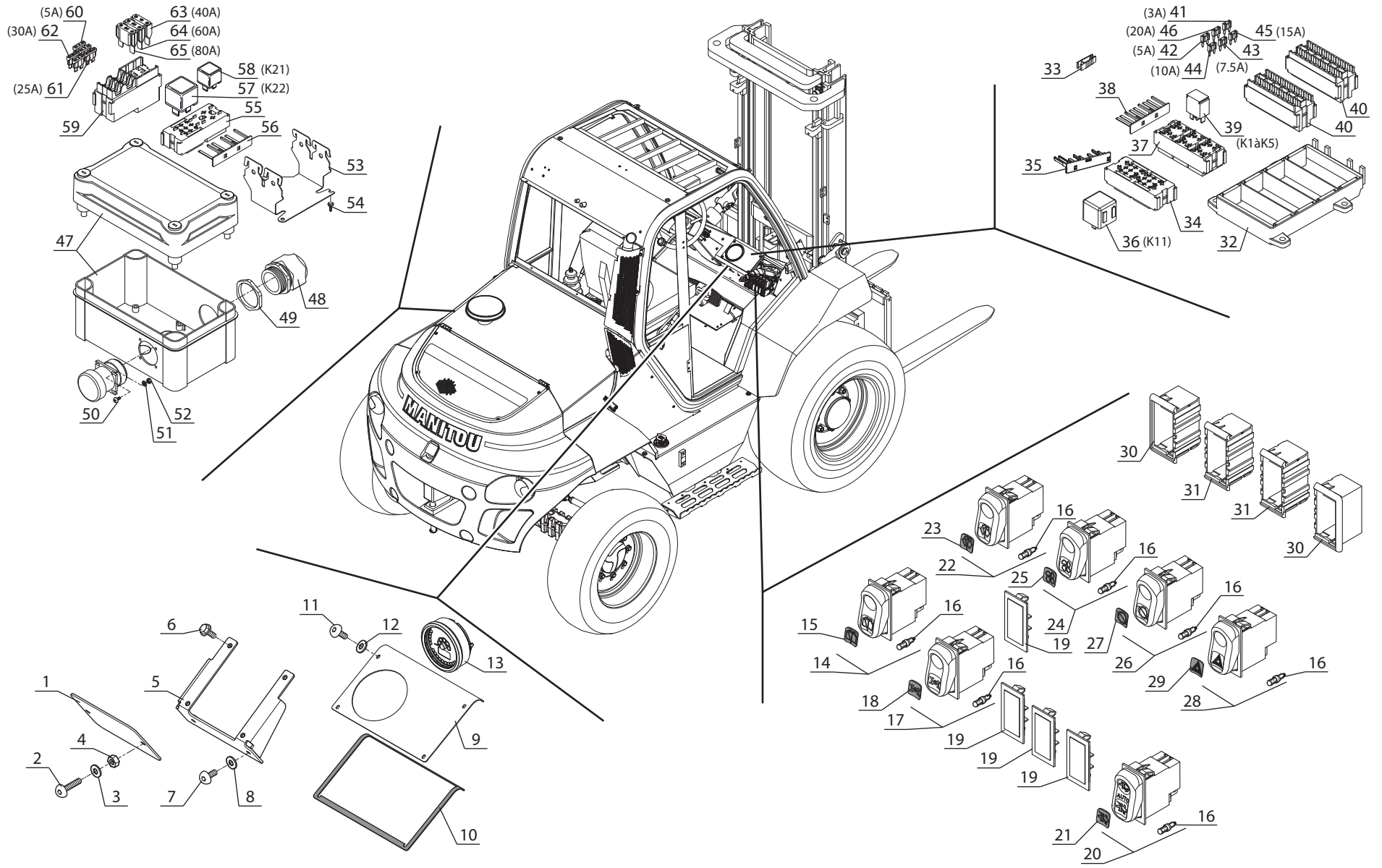

Catalogue : 647483

2	ELECTRICITE (Poste de conduite) ELEKTRIZITÄT (Fahrerstand) ELECTRICIDAD (Puesto del conductor) ELECTRICITY (Cab structure) ELECTRICO (Posto di pilotaggio)			Qte-Menge-Cant-Qty-Q.ta										11 CC 8048									
	Rep Hinw Fig Item Rif	Numéro Teil-Nr Numero Part-Nr Part-Nr	Désignation Bezeichnung Descripcion Description Descrizione	1	2	3	4	5	6	7	8	9	10	11	12	13	14	15	16	17	18	19	20
				1- M26- 2 ST3B	11 - M30- 2H ST3B																		
				2- M26- 4 ST3B	12 - M30- 4H ST3B																		
				3- M30- 2 ST3B	13 - M40- 2H ST3B																		
				4- M30- 4 ST3B	14 - M40- 4H ST3B																		
				5- M40- 2 ST3B	15 - M50- 2H ST3B																		
				6- M40- 4 ST3B	16 - M50- 4H ST3B																		
				7- M50- 2 ST3B	17 -																		
				8- M50- 4 ST3B	18 -																		
				9- M26- 2H ST3B	19 -																		
				10-M26- 4H ST3B	20 -																		
12	189858	Rondelle M5ZN PASS.NOIRE Arandela Rondella	- Unterlegscheibe - Washer	4	4	4	4	4	4	4	4	4	4	4	4	4	4	4					
13	302050	Horamètre Horametro Tachimetro	- Stundenzähler - Hour recorder	1	1	1	1	1	1	1	1	1	1	1	1	1	1	1					
14	272628	Interrupteur essuie-gl. de toit Interruptor limpia hielo de techo Interruttore pulisce ghiaccio di tetto	- Abwischen sie dacheis schal - Windscreen of roof switch	1	1	1	1	1	1	1	1	1	1	1	1	1	1	1					
15	747554	Lentille Lente Vetrino	- Linse - Lens	X	X	X	X	X	X	X	X	X	X	X	X	X	X	X					
16	170836	Ampoule Bombilla Lampadina	- Birne - Bulb	1	1	1	1	1	1	1	1	1	1	1	1	1	1	1					
17	304523	Interr. 4 roues motr. Interruptor 4 ruedas motrices Interruttore 4 ruote motrici	- Schalter 4 transporträder - Switch 4 driving wheels	0	1	0	1	0	1	0	1	0	1	0	1	0	1	0	1				
18	797952	Lentille 4 roues motr. Lente 4 ruedas motrices Vetrino 4 ruote motrici	- Linse 4 transporträder - Lens 4 driving wheels	0	1	0	1	0	1	0	1	0	1	0	1	0	1	0	1				
19	224775	Obturateur Obturador Tappo	- Stopfen - Plug	4	4	4	4	4	4	4	4	4	4	4	4	4	4	4					
20	309549	Interrupteur Interruptor Interruttore	- Schalter - Switch	1	1	1	1	1	1	1	1	1	1	1	1	1	1	1					
21	796552	Lentille Lente Vetrino	- Linse - Lens	1	1	1	1	1	1	1	1	1	1	1	1	1	1	1					

M

+

Catalogue : 647483

4	ELECTRICITE (Poste de conduite) ELEKTRIZITÄT (Fahrerstand) ELECTRICIDAD (Puesto del conductor) ELECTRICITY (Cab structure) ELECTRICO (Posto di pilotaggio)			Qte-Menge-Cant-Qty-Q.ta										11 CC 8048																													
	Rep Hinw Fig Item Rif	Numéro Teil-Nr Numero Part-Nr Part-Nr	Désignation Bezeichnung Descripcion Description Descrizione	<table border="1"> <tr> <td>1- M26- 2 ST3B</td><td>11 - M30- 2H ST3B</td> <td>2- M26- 4 ST3B</td><td>12 - M30- 4H ST3B</td> <td>3- M30- 2 ST3B</td><td>13 - M40- 2H ST3B</td> <td>4- M30- 4 ST3B</td><td>14 - M40- 4H ST3B</td> <td>5- M40- 2 ST3B</td><td>15 - M50- 2H ST3B</td> <td>6- M40- 4 ST3B</td><td>16 - M50- 4H ST3B</td> <td>7- M50- 2 ST3B</td><td>17 -</td> <td>8- M50- 4 ST3B</td><td>18 -</td> <td>9- M26- 2H ST3B</td><td>19 -</td> <td>10-M26- 4H ST3B</td><td>20 -</td> </tr> </table>																				1- M26- 2 ST3B	11 - M30- 2H ST3B	2- M26- 4 ST3B	12 - M30- 4H ST3B	3- M30- 2 ST3B	13 - M40- 2H ST3B	4- M30- 4 ST3B	14 - M40- 4H ST3B	5- M40- 2 ST3B	15 - M50- 2H ST3B	6- M40- 4 ST3B	16 - M50- 4H ST3B	7- M50- 2 ST3B	17 -	8- M50- 4 ST3B	18 -	9- M26- 2H ST3B	19 -	10-M26- 4H ST3B	20 -
				1- M26- 2 ST3B	11 - M30- 2H ST3B	2- M26- 4 ST3B	12 - M30- 4H ST3B	3- M30- 2 ST3B	13 - M40- 2H ST3B	4- M30- 4 ST3B	14 - M40- 4H ST3B	5- M40- 2 ST3B	15 - M50- 2H ST3B	6- M40- 4 ST3B	16 - M50- 4H ST3B	7- M50- 2 ST3B	17 -	8- M50- 4 ST3B	18 -	9- M26- 2H ST3B	19 -	10-M26- 4H ST3B	20 -																				
1	2	3	4	5	6	7	8	9	10	11	12	13	14	15	16	17	18	19	20																								
31	224773	Support interrupteur Soporte interruptor Supporto interruttore	- Schalter träger - Switch bracket	2	2	2	2	2	2	2	2	2	2	2	2	2	2	2	2	2																							
32	746186	Support Soporte Supporto	- Träger - Bracket	1	1	1	1	1	1	1	1	1	1	1	1	1	1	1	1	1																							
33	245295	Pince Alicates Pinze	- Zange - Pliers	1	1	1	1	1	1	1	1	1	1	1	1	1	1	1	1	1																							
34	797792	Module relais Módulo Relé Modulo rele	- Modul relais - Relay modulus	1	1	1	1	1	1	1	1	1	1	1	1	1	1	1	1	1																							
35	797793	Verrou Cerrojo Catenaccio	- Riegel - Locker	1	1	1	1	1	1	1	1	1	1	1	1	1	1	1	1	1																							
36	297210	Centrale clignotante Central intermiten. Centralina vetra	- Blinkschalter - Flasher unit	1	1	1	1	1	1	1	1	1	1	1	1	1	1	1	1	1																							
37	797314	Module Módulo Modulo	- Modul - Modulus	1	1	1	1	1	1	1	1	1	1	1	1	1	1	1	1	1																							
38	797315	Verrou Cerrojo Catenaccio	- Riegel - Locker	1	1	1	1	1	1	1	1	1	1	1	1	1	1	1	1	1																							
39	245700	Relais Relé Centralina rele	- Relais - Relay	5	5	5	5	5	5	5	5	5	5	5	5	5	5	5	5	5																							
40	748071	Module Módulo Modulo	- Modul - Modulus	2	2	2	2	2	2	2	2	2	2	2	2	2	2	2	2	2																							
41	250606	Fusible (mini 3 A) Fusible Fusibile	- Lichtsicherung - Fuse	X	X	X	X	X	X	X	X	X	X	X	X	X	X	X	X	X																							

M

+

Catalogue : 647483

Rep Hinw Fig Item Rif	Numéro Teil-Nr Numero Part-Nr Part-Nr	Désignation Bezeichnung Descripcion Description Descrizione	Qte-Menge-Cant-Qty-Q.ta										11 CC 8048									
			1	2	3	4	5	6	7	8	9	10	11	12	13	14	15	16	17	18	19	20
			6		ELECTRICITE (Poste de conduite) ELEKTRIZITÄT (Fahrerstand) ELECTRICIDAD (Puesto del conductor) ELECTRICITY (Cab structure) ELECTRICO (Posto di pilotaggio)	1- M26- 2 ST3B 2- M26- 4 ST3B 3- M30- 2 ST3B 4- M30- 4 ST3B 5- M40- 2 ST3B 6- M40- 4 ST3B 7- M50- 2 ST3B 8- M50- 4 ST3B 9- M26- 2H ST3B 10-M26- 4H ST3B										11 - M30- 2H ST3B 12 - M30- 4H ST3B 13 - M40- 2H ST3B 14 - M40- 4H ST3B 15 - M50- 2H ST3B 16 - M50- 4H ST3B 17 - 18 - 19 - 20 -						
53	279148	Support Soporte Supporto - Halter - Bracket	1	1	1	1	1	1	1	1	1	1	1	1	1	1	1					
54	192041	Vis CLS, ST 3,5-9,5-F-ZN12/C Tornillo Vite - Schraube - Screw	3	3	3	3	3	3	3	3	3	3	3	3	3	3	3					
55	797762	Module Módulo Modulo - Modul - Modulus	1	1	1	1	1	1	1	1	1	1	1	1	1	1	1					
56	797763	Verrou Cerrojo Catenaccio - Riegel - Locker	1	1	1	1	1	1	1	1	1	1	1	1	1	1	1					
57	288318	Relais (70 A) Relé Centralina rele - Relais - Relay	1	1	1	1	1	1	1	1	1	1	1	1	1	1	1					
58	231245	Relais Relé Centralina rele - Relais - Relay	1	1	1	1	1	1	1	1	1	1	1	1	1	1	1					
59	795611	Module Módulo Modulo - Modul - Modulus	1	1	1	1	1	1	1	1	1	1	1	1	1	1	1					
60	207007	Fusible (5 A) Fusible Fusibile - Lichtsicherung - Fuse	X	X	X	X	X	X	X	X	X	X	X	X	X	X	X					
61	473080	Fusible (25A) Fusible Fusibile - Lichtsicherung - Fuse	X	X	X	X	X	X	X	X	X	X	X	X	X	X	X					
62	473081	Fusible (30A) Fusible Fusibile - Lichtsicherung - Fuse	X	X	X	X	X	X	X	X	X	X	X	X	X	X	X					
63	243480	Fusible (40A) Fusible Fusibile - Lichtsicherung - Fuse	X	X	X	X	X	X	X	X	X	X	X	X	X	X	X					

M

+

Catalogue : 647483

7	ELECTRICITE (Poste de conduite) ELEKTRIZITÄT (Fahrerstand) ELECTRICIDAD (Puesto del conductor) ELECTRICITY (Cab structure) ELECTRICO (Posto di pilotaggio)			Qte-Menge-Cant-Qty-Q.ta										11 CC 8048									
	Rep Hinw Fig Item Rif	Número Teil-Nr Numero Part-Nr Part-Nr	Désignation Bezeichnung Descripcion Description Descrizione	1	2	3	4	5	6	7	8	9	10	11	12	13	14	15	16	17	18	19	20
64	251178	Fusible (60A) Fusible Fusibile	- Lichtsicherung - Fuse	X	X	X	X	X	X	X	X	X	X	X	X	X	X	X	X				
65	243481	Fusible (80A) Fusible Fusibile	- Lichtsicherung - Fuse	X	X	X	X	X	X	X	X	X	X	X	X	X	X	X	X				

M

11 CC 8049

ELECTRICITE (Poste de conduite)
 ELEKTRIZITÄT (Fahrerstand)
 ELECTRICIDAD (Puesto del conductor)
 ELECTRICITY (Cab structure)
 ELETTRICO (Posto di pilotaggio)

M 26-2/4 ST3B	M 26-2/4H ST3B
M 30-2/4 ST3B	M 30-2/4H ST3B
M 40-2/4 ST3B	M 40-2/4H ST3B
M 50-2/4 ST3B	M 50-2/4H ST3B

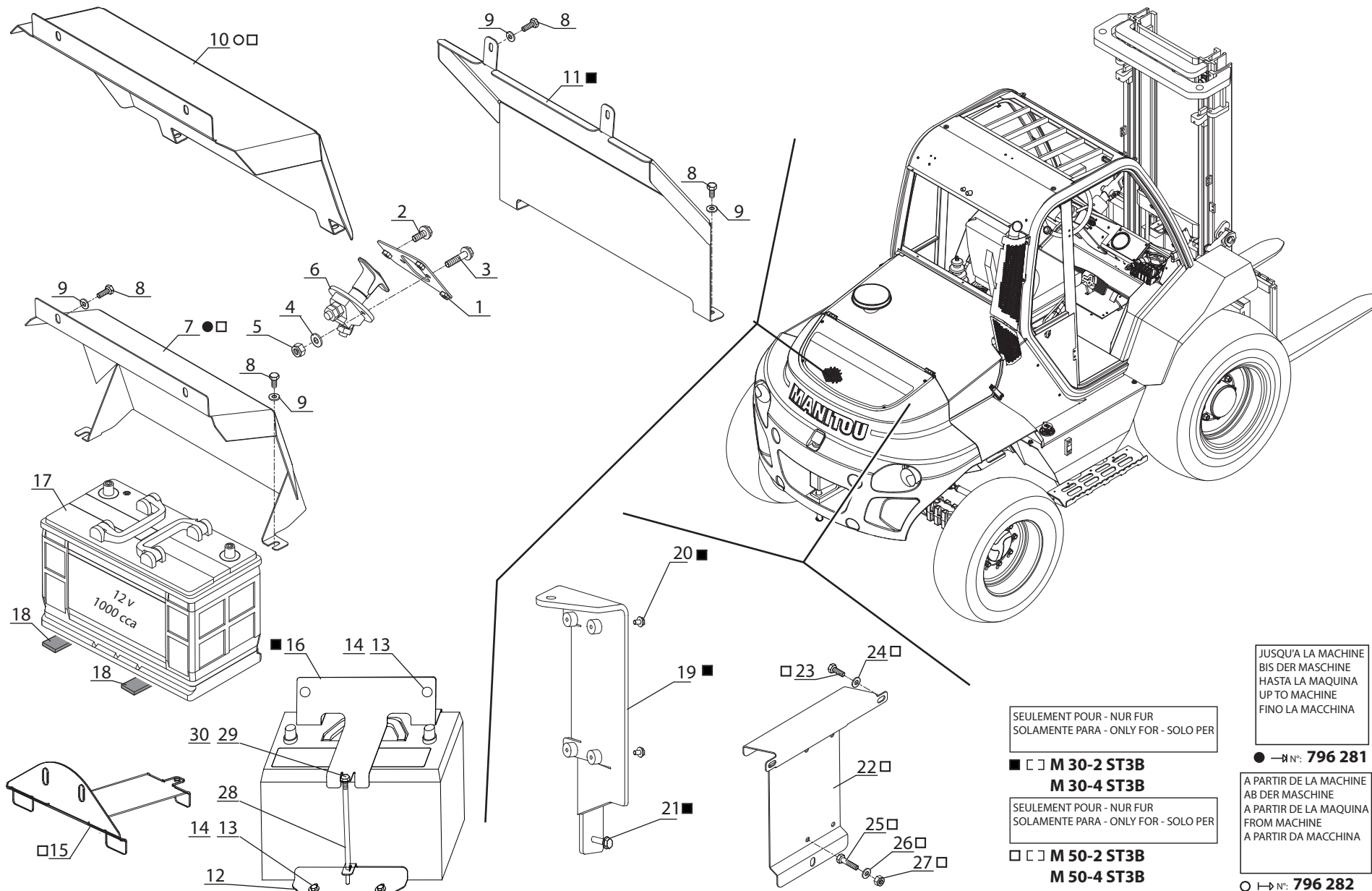

SEULEMENT POUR - NUR FÜR
 SOLAMENTE PARA - ONLY FOR - SOLO PER

■ □ M 30-2 ST3B
 M 30-4 ST3B

SEULEMENT POUR - NUR FÜR
 SOLAMENTE PARA - ONLY FOR - SOLO PER

□ □ M 50-2 ST3B
 M 50-4 ST3B

JUSQU'À LA MACHINE
 BIS DER MASCHINE
 HASTA LA MAQUINA
 UP TO MACHINE
 FINO LA MACCHINA

● → N°: 796 281

A PARTIR DE LA MACHINE
 AB DER MASCHINE
 A PARTIR DE LA MAQUINA
 FROM MACHINE
 A PARTIR DA MACCHINA

○ → N°: 796 282

Catalogue : 647483

Rep Hinw Fig Item Rif	Numéro Teil-Nr Numero Part-Nr Part-Nr	Désignation Bezeichnung Descripcion Description Descrizione	Qte-Menge-Cant-Qty-Q.ta										11 CC 8049									
			1	2	3	4	5	6	7	8	9	10	11	12	13	14	15	16	17	18	19	20
			1	307026	Platine Platina Piastra - Anschluss - Delivery port conn.	1	1	1	1	1	1	1	1	1	1	1	1	1	1	1		
2	278713	Vis H EMB M 6-10-8.8-ZN8/C Tornillo Vite - Schraube - Screw	3	3	3	3	3	3	3	3	3	3	3	3	3	3	3					
3	240822	Vis H EMB M6-20 8.8DIN6921 Tornillo Vite - Schraube - Screw	2	2	2	2	2	2	2	2	2	2	2	2	2	2	2					
4	29469	Rondelle M 6 ZN Arandela Rondella - Unterlegscheibe - Washer	2	2	2	2	2	2	2	2	2	2	2	2	2	2	2					
5	162229	Ecrou H,FR M6C 8 ZN.C Tuerca Dado - Mutter - Nut	3	3	3	3	3	3	3	3	3	3	3	3	3	3	3					
6	518886	Coupe-batterie Corte batería Interruttore batteria - Unterbrecher - Breaker circuit	1	1	1	1	1	1	1	1	1	1	1	1	1	1	1					
7	300539	Tôle Chapa Lamiera - Blech - Sheat	1	1	1	1	1	1	1	1	1	1	1	1	1	1	1					
8	25713	Vis H,M 6-16-8.8-ZN5/C Tornillo Vite - Schraube - Screw	4	4	4	4	4	4	4	4	4	4	4	4	4	4	4					
9	198138	Rondelle L6 zinguée noire Arandela Rondella - Unterlegscheibe - Washer	4	4	4	4	4	4	4	4	4	4	4	4	4	4	4					
10	300534	Tôle Chapa Lamiera - Blech - Sheat					1	1	1	1				1	1	1	1					
11	303208	Tôle Chapa Lamiera - Blech - Sheat	1	1	1	1					1	1	1	1								

+

M

Catalogue : 647483

Rep Hinw Fig Item Rif	Numéro Teil-Nr Numero Part-Nr Part-Nr	Désignation Bezeichnung Descripcion Description Descrizione	Qte-Menge-Cant-Qty-Q.ta										11 CC 8049									
			1- M26- 2 ST3B					11 - M30- 2H ST3B					2- M26- 4 ST3B					12 - M30- 4H ST3B				
			3- M30- 2 ST3B					13 - M40- 2H ST3B					4- M30- 4 ST3B					14 - M40- 4H ST3B				
2		ELECTRICITE (Poste de conduite) ELEKTRIZITÄT (Fahrerstand) ELECTRICIDAD (Puesto del conductor) ELECTRICITY (Cab structure) ELECTRICO (Posto di pilotaggio)	5- M40- 2 ST3B					15 - M50- 2H ST3B					6- M40- 4 ST3B					16 - M50- 4H ST3B				
			7- M50- 2 ST3B					17 -					8- M50- 4 ST3B					18 -				
			9- M26- 2H ST3B					19 -					10-M26- 4H ST3B					20 -				
			1	2	3	4	5	6	7	8	9	10	11	12	13	14	15	16	17	18	19	20
12	51300578	Patte de fixation Brida de fijación Flangia di fissaggio	- Befestigung auge - Fastening lug	1	1	1	1	1	1	1	1	1	1	1	1	1	1	1				
13	261501	Vis H,M 6-14-8.8-ZN/5C FR Tornillo Vite	- Schraube - Screw	4	4	4	4	4	4	4	4	4	4	4	4	4	4	4				
14	198138	Rondelle L6 zinguée noire Arandela Rondella	- Unterlegscheibe - Washer	4	4	4	4	4	4	4	4	4	4	4	4	4	4	4				
15	51300579	Support batterie Soporte batería Supporto batteria	- Batterie Halter - Battery bracket	1	1	1	1					1	1	1	1							
16	51300580	Support batterie Soporte batería Supporto batteria	- Batterie Halter - Battery bracket					1	1	1	1				1	1	1	1				
17	51300732	Batterie Batería Batteria	- Batterie - Battery	1	1	1	1	1	1	1	1	1	1	1	1	1	1	1				
18	41077	Bande caoutchouc Cinta goma Gomma	- Gummireifen - Rubber strip	2	2	2	2	2	2	2	2	2	2	2	2	2	2	2				
19	51300723	Support Soporte Supporto	- Halter - Bracket	1	1	1	1					1	1	1	1							
20	273436	Vis H,M 6-25-8.8-ZN5/C FR Tornillo Vite	- Schraube - Screw	4	4	4	4					4	4	4	4							
21	286323	Vis H EMB M6-10-8.8-ZN8/C FR Tornillo Vite	- Schraube - Screw	2	2	2	2					2	2	2	2							
22	310006	Support Soporte Supporto	- Halter - Bracket					1	1	1	1				1	1	1	1				

M

+

11 CD 8050

ELECTRICITE (Moteur - Transmission)
ELEKTIZITÄT (Motor - Getriebe)
ELECTRICIDAD (Motor - Transmission)
ELECTRICITY (Engine - Transmission)
ELETRICO (Motore - Trasmissione)

M 26-2/4 ST3B	M 26-2/4H ST3B
M 30-2/4 ST3B	M 30-2/4H ST3B
M 40-2/4 ST3B	M 40-2/4H ST3B
M 50-2/4 ST3B	M 50-2/4H ST3B

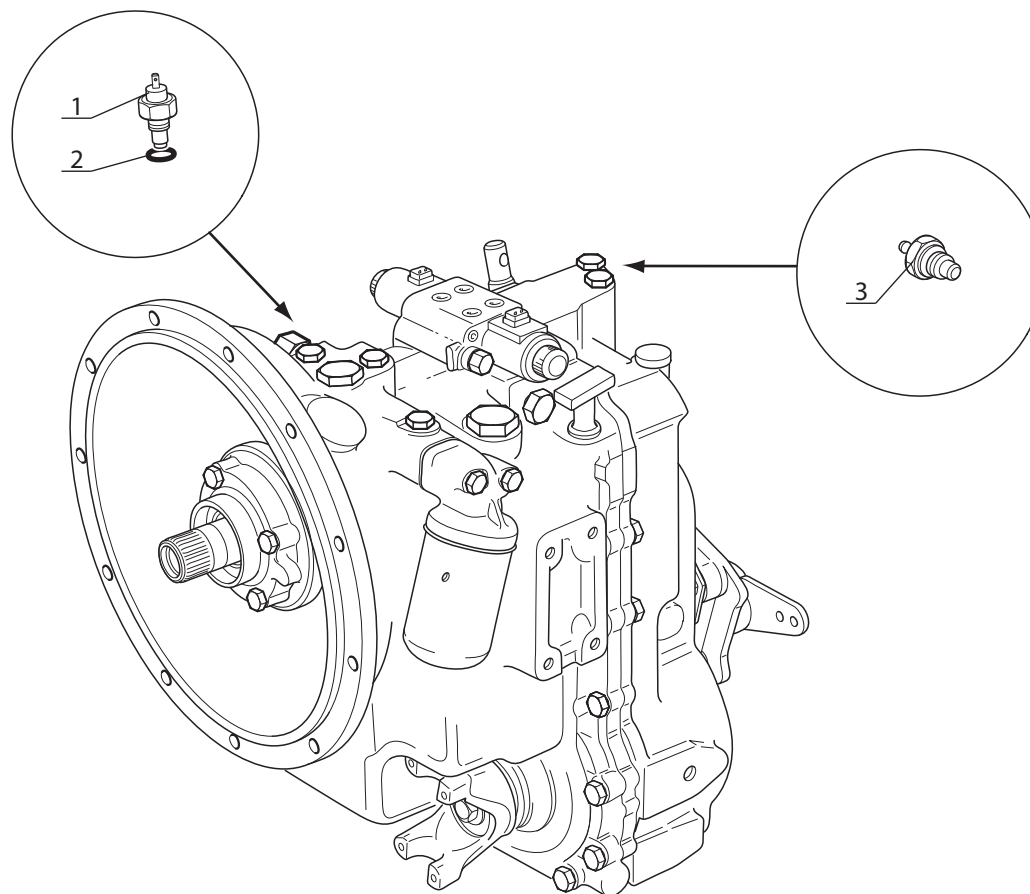

Catalogue : 647483

1	ELECTRICITE (Moteur - Transmission) ELEKTIZITÄT (Motor - Getreibe) ELECTRICIDAD (Motor - Transmission) ELECTRICITY (Engine - Transmission) ELETTRICO (Motore - Trasmissione)			Qte-Menge-Cant-Qty-Q.ta										11 CD 8050									
	Rep Hinw Fig Item Rif	Numéro Teil-Nr Numero Part-Nr Part-Nr	Désignation Bezeichnung Descripcion Description Descrizione	1	2	3	4	5	6	7	8	9	10	11	12	13	14	15	16	17	18	19	20
1	702388	Sonde de température huile Sonda de temperatura de aceite Sonda temperatura olio	- Ol temperatur transmitter - Oil temperature sensor	1	1	1	1	1	1	1	1	1	1	1	1	1	1	1	1				
2	109657	Joint torique Junta tórica Anello OR	- "0" ring - "0" ring	1	1	1	1	1	1	1	1	1	1	1	1	1	1	1	1				
3	705009	Mano-contact pression huile transmission Ol transmission druckschalter Mano contacto presión de aceite transmisión Transm oil pressure switch Interruttore pressione olio trasmissione		1	1	1	1	1	1	1	1	1	1	1	1	1	1	1	1				

M

11 CD 8060

SCHEMA - HIDROSTATIQUE
 SCHEMA HYDROSTATISCHEN
 ESQUEMA - HIDROSTATICO
 LAYOUT - HYDROSTATIC
 SCHEMA - IDROSTATICA

26-2/4H ST3B
 30-2/4H ST3B
 40-2/4H ST3B
 50-4/4H ST3B

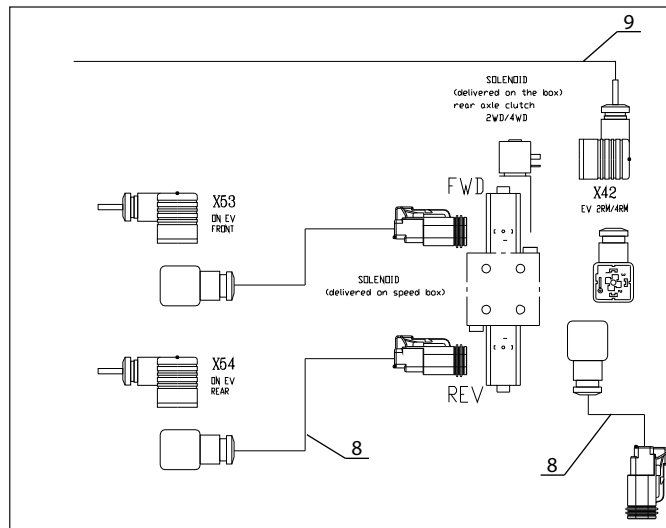
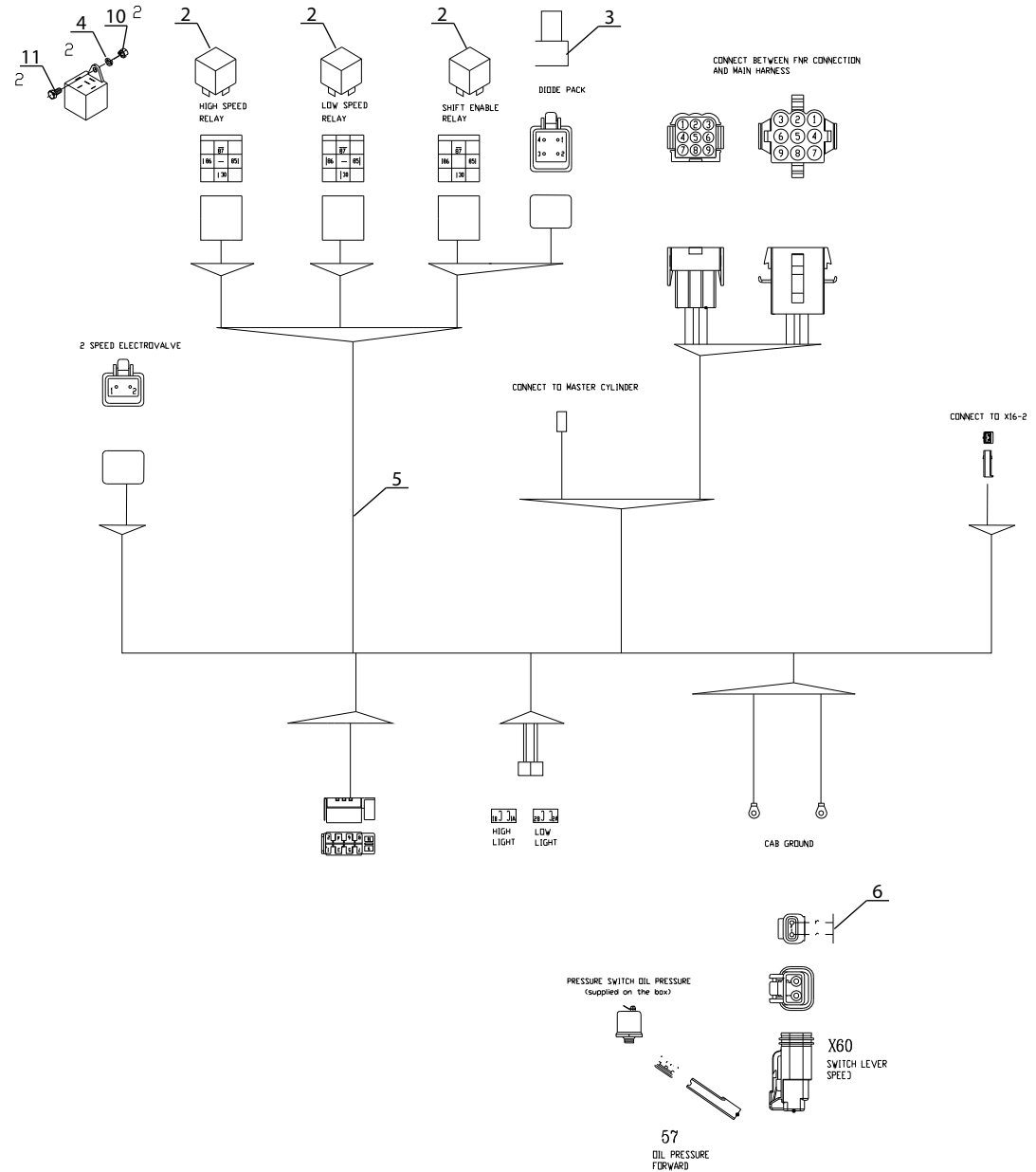
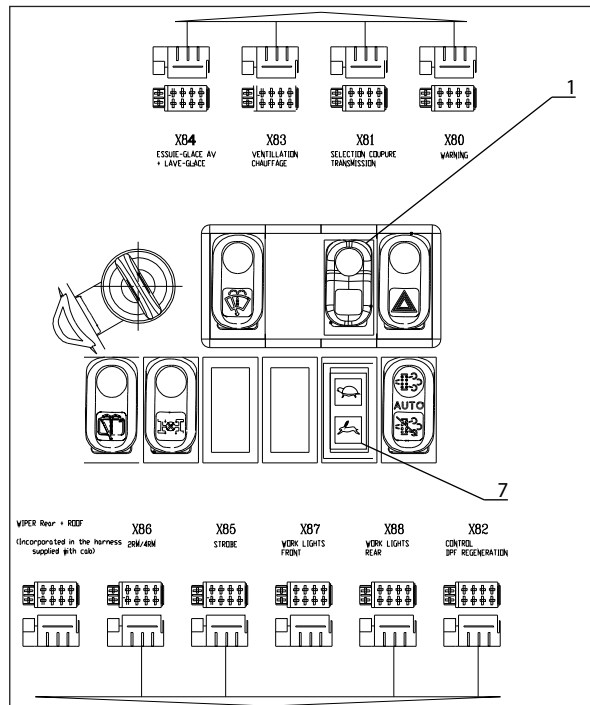

Catalogue : 647483

1	SCHEMA - HIDROSTATIQUE SCHEMA HYDROSTATISCHEN ESQUEMA - HIDROSTATICO LAYOUT - HYDROSTATIC SCHEMA - IDROSTATICA			Qte-Menge-Cant-Qty-Q.ta																11 CD 8060				M
	Rep Hinw Fig Item Rif	Numéro Teil-Nr Numero Part-Nr Part-Nr	Désignation Bezeichnung Descripcion Description Descrizione	1	2	3	4	5	6	7	8	9	10	11	12	13	14	15	16	17	18	19	20	
1	272648	Commutateur 2 vitesses Switch 2 Speed Interruttore 2 velocità	- Schalten 2 Geschwindigkeit - Interruptor de 2 velocidades									1	1	1	1	1	1	1	1					
2	806876	Relais Tyco/Bosch Relay, 12v 30a Std Relé	- Relais - Relé									3	3	3	3	3	3	3	3					
3	800465	Module Module, Diode Modulo	- Modul - Módulo									1	1	1	1	1	1	1	1					
4	28959	Rondelle Washer, M5 Plated Flat Unterlegscheibe	- Unterlegscheibe - Rondelle									2	2	2	2	2	2	2	2					
5	51300990	Harnais 2 Vitesse Harness 2 Speed Imbrigliare 2 Velocità	- Harness 2 Geschwindigkeit - Arnés de 2 velocidades									1	1	1	1	1	1	1	1					
6	802784	Jumper Jumper Jumper	- Jumper - Puente									1	1	1	1	1	1	1	1					
7	231464	Haut / Bas Vitesse Lumière High Low Gear Light Luce High / Low ingranaggi	- High / Low Gang Licht - Luz de Alta/Baja									1	1	1	1	1	1	1	1					
8	51301006	Harnais Jumper Harness Jumper Harness Jumper	- Harness Jumper - Puente de Arnes									2	3	2	3	2	3	2	3					
9	802936	Harnais Montage Harness Assy Cablaggio Assemblaggio	- Baummontage - Arnés Ensemble									1	1	1	1	1	1	1	1					
10	54232	Ecrou Nut, H.M5 C8 Dado	- Mutter - Tuerca									10	10	10	10	10	10	10	10					
11	79533	Vis Bolt CBHC M 5-10-10.9-Zn5/Noir Vite	- Schraube - Tornillo									4	4	4	4	4	4	4	4					

12 AA 8051

ADHESIFS
KLEBSTOFF
ADHESIVO
ADHESIVE
ADESIVO

M 26-2/4 ST3B
M 30-2/4 ST3B
M 40-2/4 ST3B
M 50-2/4 ST3B

M 26-2/4H ST3B
M 30-2/4H ST3B
M 40-2/4H ST3B
M 50-2/4H ST3B

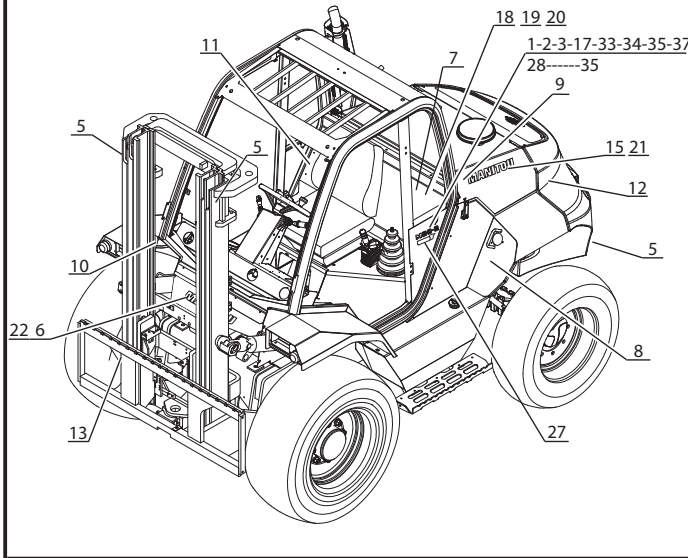

23 1 | M30-2 M26-2
24 2 | M30-4 M26-2
26 17 | M50-2 M40-2
25 3 | M50-4 M40-4

MANITOU
500 mm

MANITOU
300 mm

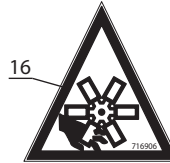
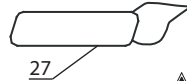

8

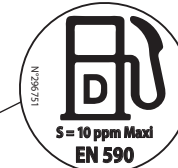
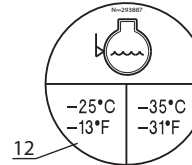
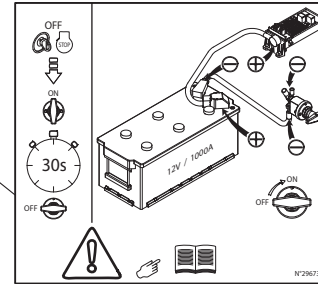

5



MANITOU		MANITOU		MANITOU	
MODEL	MODEL	MODEL	SEDE	SEDE	SEDE
MODEL	MODEL	MODEL	SEDE	SEDE	SEDE
Année de fabrication / Year of manufacture / Año de fabricación / Annullationsjahr N° de série / Number of serie / Serial / Seriennummer		Année modèle / Año modelo / Modeller / Modelljahr N° de série / Number of serie / Serial / Seriennummer		Référence / Reference / Referenz / Referenznummer Page / Page / Seite / Seitennummer Référence / Reference / Referenz / Referenznummer	
Masse à vide / Mass a vuoto / Legegewicht / Legegewicht Poids net / Netto peso / Nettogewicht / Nettogewicht		Capacité max. nominale / Nominal capacity / Nennleistung / Nennleistung Capacité max. réelle / Actual capacity / Wirkleistung / Wirkleistung Capacité max. nominale / Nominal capacity / Nennleistung / Nennleistung		Capacité max. nominale / Nominal capacity / Nennleistung / Nennleistung Capacité max. réelle / Actual capacity / Wirkleistung / Wirkleistung Capacité max. nominale / Nominal capacity / Nennleistung / Nennleistung	
PTA / PTA / Max. tonnage / Max. tonnage No. ton weight / P.T.A. / Max. tonnage / Max. tonnage		PTA / PTA / Max. tonnage / Max. tonnage No. ton weight / P.T.A. / Max. tonnage / Max. tonnage		PTA / PTA / Max. tonnage / Max. tonnage No. ton weight / P.T.A. / Max. tonnage / Max. tonnage	
Effort de traction / Force de traction / Tractive effort / Tractive effort Effort de traction / Force de traction / Tractive effort / Tractive effort		Effort de traction / Force de traction / Tractive effort / Tractive effort Effort de traction / Force de traction / Tractive effort / Tractive effort		Effort de traction / Force de traction / Tractive effort / Tractive effort Effort de traction / Force de traction / Tractive effort / Tractive effort	
Pression des pneumatiques (bar) / Pneumatic pressure (bar) / Pression des pneumatiques (bar) / Pneumatic pressure (bar)		Pression des pneumatiques (bar) / Pneumatic pressure (bar) / Pression des pneumatiques (bar) / Pneumatic pressure (bar)		Pression des pneumatiques (bar) / Pneumatic pressure (bar) / Pression des pneumatiques (bar) / Pneumatic pressure (bar)	
Type pneumatic / Type pneumatic / Type pneumatic / Type pneumatic Pression des pneumatiques (bar) / Pneumatic pressure (bar) / Pression des pneumatiques (bar) / Pneumatic pressure (bar)		Type pneumatic / Type pneumatic / Type pneumatic / Type pneumatic Pression des pneumatiques (bar) / Pneumatic pressure (bar) / Pression des pneumatiques (bar) / Pneumatic pressure (bar)		Type pneumatic / Type pneumatic / Type pneumatic / Type pneumatic Pression des pneumatiques (bar) / Pneumatic pressure (bar) / Pression des pneumatiques (bar) / Pneumatic pressure (bar)	
Année / Année / Année / Année Année / Année / Année / Année		Année / Année / Année / Année Année / Année / Année / Année		Année / Année / Année / Année Année / Année / Année / Année	

18 20

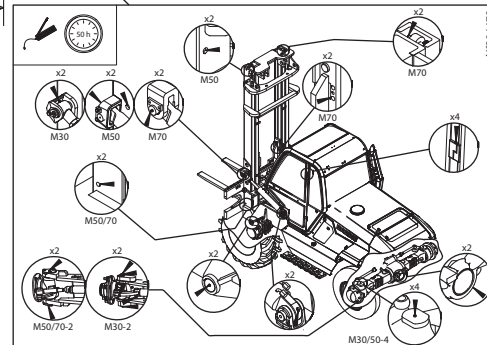
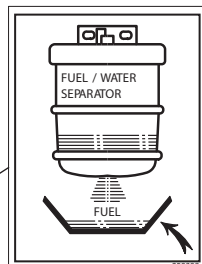

Catalogue : 647483

1	ADHESIFS KLEBSTOFF ADHESIVO ADHESIVE ADESIVO			Qte-Menge-Cant-Qty-Q.ta										12 AA 8051									
	Rep Hinw Fig Item Rif	Numéro Teil-Nr Numero Part-Nr Part-Nr	Désignation Bezeichnung Descripcion Description Descrizione	1- M26- 2 ST3B 2- M26- 4 ST3B 3- M30- 2 ST3B 4- M30- 4 ST3B 5- M40- 2 ST3B 6- M40- 4 ST3B 7- M50- 2 ST3B 8- M50- 4 ST3B 9- M26- 2H ST3B 10-M26- 4H ST3B										11 - M30- 2H ST3B 12 - M30- 4H ST3B 13 - M40- 2H ST3B 14 - M40- 4H ST3B 15 - M50- 2H ST3B 16 - M50- 4H ST3B 17 - 18 - 19 - 20 -									
				1	2	3	4	5	6	7	8	9	10	11	12	13	14	15	16	17	18	19	20
1	219416	Adhésif "M30-2" Adhesivo Adesivo	- Klebstoff - Adhesive			2									2								
2	219418	Adhésif "M30-4" Adhesivo Adesivo	- Klebstoff - Adhesive				2								2								
3	219421	Adhésif "M50-4" Adhesivo Adesivo	- Klebstoff - Adhesive							2									2				
4	305405	Adhésif "Diesel P210" Adhesivo Adesivo	- Klebstoff - Adhesive	1	1	1	1	1	1	1	1	1	1	1	1	1	1	1	1	1			
5	24653	Adhésif "Crochet point d'élingage" Adhesivo Adesivo	- Klebstoff - Adhesive	5	5	5	5	5	5	5	5	5	5	5	5	5	5	5	5	5			
6	240808	Adhésif "MANITOU" Lg500 Adhesivo Adesivo	- Klebstoff - Adhesive	1	1	1	1	1	1	1	1	1	1	1	1	1	1	1	1	1			
7	239595	Plaque "Puissance acoust 105dB" Placa Piastra	- Platte - Plate	1	1	1	1	1	1	1	1	1	1	1	1	1	1	1	1	1			
8	309443	Adhésif "Dépannage/Coupe-batt." Adhesivo Adesivo	- Klebstoff - Adhesive	1	1	1	1	1	1	1	1	1	1	1	1	1	1	1	1	1			
9	259398	Adhésif "Séparateur eau/fuel" Adhesivo Adesivo	- Klebstoff - Adhesive	1	1	1	1	1	1	1	1	1	1	1	1	1	1	1	1	1			
10	268491	Fiche "Indicateur liquide fr." Ficha Spina	- Blatt - Card	1	1	1	1	1	1	1	1	1	1	1	1	1	1	1	1	1			
11	304478	Adhésif "Graissage" Adhesivo Adesivo	- Klebstoff - Adhesive	1	1	1	1	1	1	1	1	1	1	1	1	1	1	1	1	1			

M

+

Catalogue : 647483

2	ADHESIFS KLEBSTOFF ADHESIVO ADHESIVE ADESIVO			Qte-Menge-Cant-Qty-Q.ta										12 AA 8051									
	Rep Hinw Fig Item Rif	Numéro Teil-Nr Numero Part-Nr Part-Nr	Désignation Bezeichnung Descripcion Description Descrizione	1	2	3	4	5	6	7	8	9	10	11	12	13	14	15	16	17	18	19	20
12	293887	Adhésif "Antigel" Adhesivo Adesivo	- Klebstoff - Adhesive	1	1	1	1	1	1	1	1	1	1	1	1	1	1	1					
13	288174	Adhésif Adhesivo Adesivo	- Klebstoff - Adhesive	1	1	1	1	1	1	1	1	1	1	1	1	1	1	1					
14	234798	Adhésif "Huile hydr.lev." Adesivo Adesivo	- Klebstoff - Adhesive	1	1	1	1	1	1	1	1	1	1	1	1	1	1	1					
15	240807	Adhésif "MANITOU" Lg300 (blanc) Adhesivo (blanco) Adesivo (bianco)	- Klebstoff (weiss) - Adhesive (white)	2	2	2	2	2	2	2	2	2	2	2	2	2	2	2					
16	716906	Adhésif "Danger Coupure Vent." Adhesivo Adesivo	- Klebstoff - Adhesive	1	1	1	1	1	1	1	1	1	1	1	1	1	1	1					
17	303890	Adhésif "M50-2" Lg286 Adhesivo Adesivo	- Klebstoff - Adhesive							2							2						
18	51300591	Tableau des spécifications Tabla de Especificaciones Tabella delle specifiche	- Tabelle Technische Daten - Specs. Table	1	1	1	1	1	1	1	1	1	1	1	1	1	1	1					
19	163658	Rivets Remaches Remaches	- Nieten - Rivet 3.2 x RF16630410	4	4	4	4	4	4	4	4	4	4	4	4	4	4	4					
20	295449	Plaque de données Placa de datos Placa de datos	- Datenplatte - Data Plate-Const Isotr	1	1	1	1	1	1	1	1	1	1	1	1	1	1	1					
21	267789	Adhésif "MANITOU"Rouge Lg300 Adhesivo Adesivo	- Klebstoff - Adhesive	1	1	1	1	1	1	1	1	1	1	1	1	1	1	1					

M

+

Catalogue : 647483

3	ADHESIFS KLEBSTOFF ADHESIVO ADHESIVE ADESIVO		Qte-Menge-Cant-Qty-Q.ta										12 AA 8051										
	Rep Hinw Fig Item Rif	Numéro Teil-Nr Numero Part-Nr Part-Nr	Désignation Bezeichnung Descripcion Description Descrizione	1	2	3	4	5	6	7	8	9	10	11	12	13	14	15	16	17	18	19	20
22	267942	Adhésif "MANITOU" Rouge Lg500 Adhesivo Adesivo	- Klebstoff - Adhesive	1	1	1	1	1	1	1	1	1	1	1	1	1	1	1	1				
23	267934	Adhésif "M30-2" Rouge L283 Adhesivo Adesivo	- Klebstoff - Adhesive			2								2									
24	267936	Adhésif "M30-4" Rouge L293 Adhesivo Adesivo	- Klebstoff - Adhesive				2								2								
25	267939	Adhésif "M50-4" Adhesivo Adesivo	- Klebstoff - Adhesive							2									2				
26	304185	Adhésif "M50-2" Rouge Lg286 Adhesivo Adesivo	- Klebstoff - Adhesive							2								2					
27	309207	Adhésif ST3B Compl. Adhesivo Adesivo	- Klebstoff - Adhesive	1	1	1	1	1	1	1	1	1	1	1	1	1	1	1	1				
28	219420	Adhésif "M40-4" (blanc) Adhesivo Adesivo	- Klebstoff - Adhesive						2								2						
29	267938	Adhésif "M40-4" Rouge Adhesivo Adesivo	- Klebstoff - Adhesive						2								2						
30	51300845	Adhésif "M40-2" (blanc) Adhesivo Adesivo	- Klebstoff - Adhesive					2								2							
31	51300846	Adhésif "M40-2" Rouge Adhesivo Adesivo	- Klebstoff - Adhesive					2								2							
32	219417	Adhésif "M26-4" (blanc) Adhesivo	- Klebstoff - Adhesive		2								2										

M

+

Catalogue : 647483

4	ADHESIFS KLEBSTOFF ADHESIVO ADHESIVE ADESIVO			Qte-Menge-Cant-Qty-Q.ta										12 AA 8051									
	Rep Hinw Fig Item Rif	Número Teil-Nr Numero Part-Nr Part-Nr	Désignation Bezeichnung Descripcion Description Descrizione	1	2	3	4	5	6	7	8	9	10	11	12	13	14	15	16	17	18	19	20
33	267935	Adesivo Adhésif "M26-4" Rouge Adhesivo Adesivo	- Klebstoff - Adhesive		2								2										
34	219415	Adhésif "M26-2" (blanc) Adhesivo Adesivo	- Klebstoff - Adhesive		2							2											
35	267933	Adhésif "M26-2" Rouge Adhesivo Adesivo	- Klebstoff - Adhesive		2							2											

M

12 AA 8052

ADHESIFS
KLEBSTOFF
ADHESIVO
ADHESIVE
ADESIVO

M 26-2/4 ST3B	M 26-2/4H ST3B
M 30-2/4 ST3B	M 30-2/4H ST3B
M 40-2/4 ST3B	M 40-2/4H ST3B
M 50-2/4 ST3B	M 50-2/4H ST3B

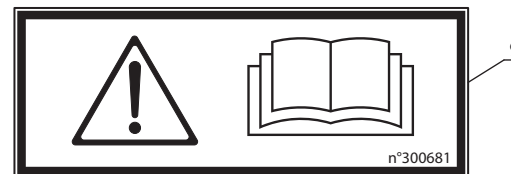
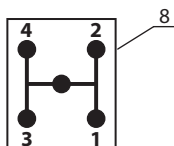
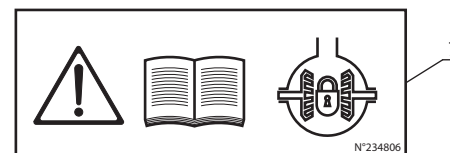
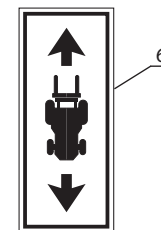
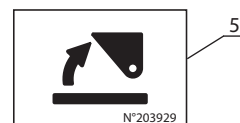
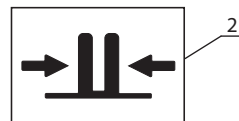
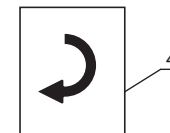
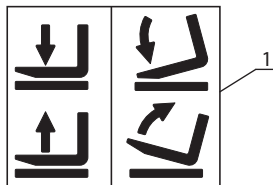
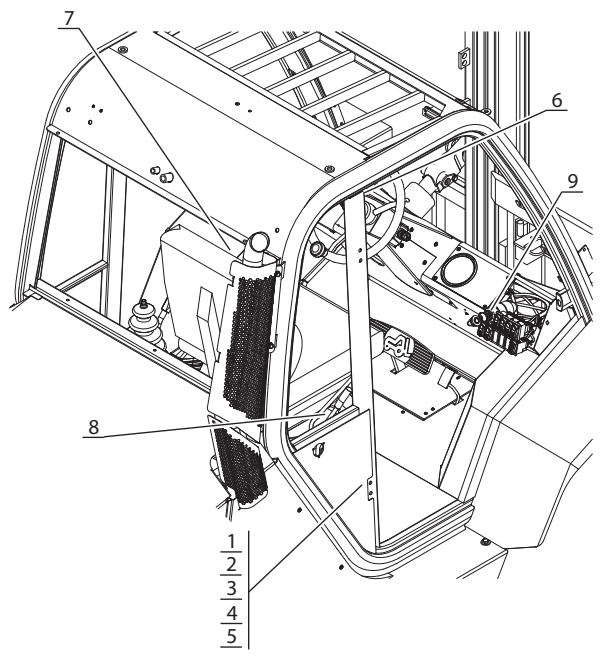

12 AA 8053

ADHESIFS
KLEBSTOFF
ADHESIVO
ADHESIVE
ADESIVO

M 26-2/4 ST3B M 26-2/4H ST3B
M 30-2/4 ST3B M 30-2/4H ST3B
M 40-2/4 ST3B M 40-2/4H ST3B
M 50-2/4 ST3B M 50-2/4H ST3B

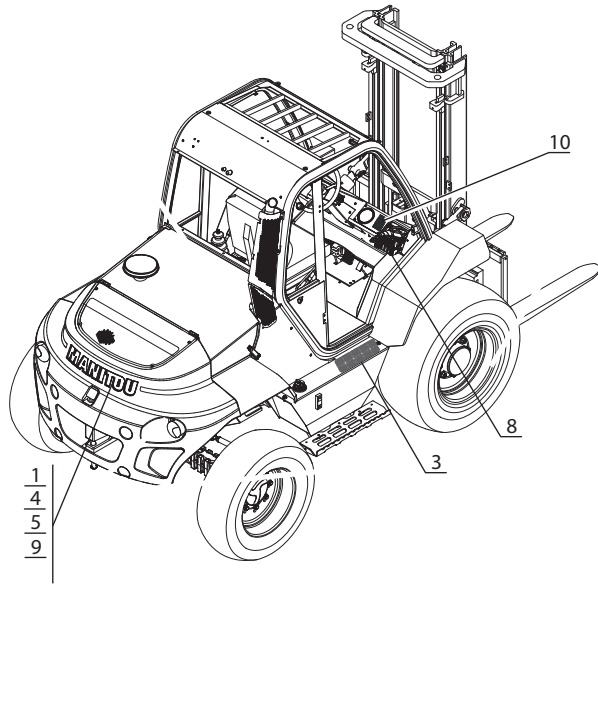

N°309444

K11		K12	
K6	DPT	K5	K4
K3	K2	K1	
F10	F9	F8	F7
F6	F5	F4	F3
F2	F1		
F20	F19	F18	F17
F16	F15	F14	F13
F12	F11		
F30	F29	F28	F27
F26	F25	F24	F23
F22	F21		
F40	F39	F38	F37
F36	F35	F34	F33
F32	F31		

Packing Kit

MANITOU Americas
6461 Imperial Drive, P.O. Box 22286
 Reno, NV 89522 - USA
 Tel: +1 775 799 7325
 Fax: +1 775 799 7325
 WWW.MANITOU.COM

Poids BRUT _____
Poids NET _____

DESTINATAIRE : _____

MARQUES : _____ N° COLIS _____

N°97226

MANITOU

635 mm

MOTEUR - MOTOR

MOTOR - ENGINE

MOTORE

TYPE - TYPEN

TIPO - TYPE

TIPO

JS 71001

REFERENCE - NUMMER

NUMERO - NUMBER

RIFERIMENTO

298 453

AP 8064

POUR MOTEUR
FÜR MOTOR
PARA MOTOR
FOR ENGINE
PER MOTORE

Type: **JS 71001**
 Ref: **298 453**

ADAPTATION MOTEUR
MOTOR ANPASSUNG
ADAPTACION MOTOR
ENGINE ADAPTATION
ADATTAMENTO MOTORE

M 26-2/4 ST3B
M 30-2/4 ST3B
M 40-2/4 ST3B
M 50-2/4 ST3B

M 26-2/4H ST3B
M 30-2/4H ST3B
M 40-2/4H ST3B
M 50-2/4H ST3B

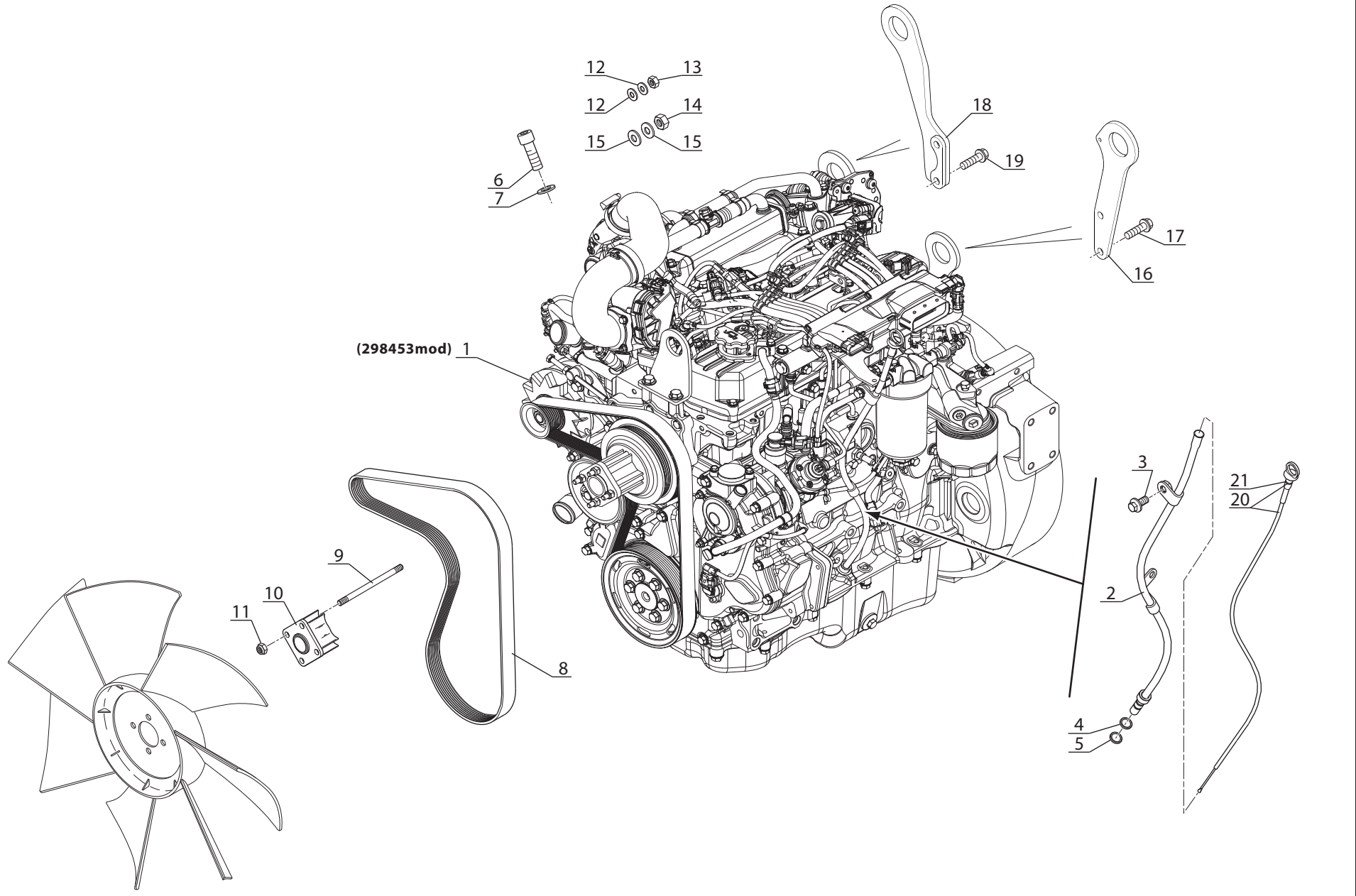

Catalogue : 647483

Rep Hinw Fig Item Rif	Numéro Teil-Nr Numero Part-Nr Part-Nr	Désignation Bezeichnung Descripcion Description Descrizione	Qte-Menge-Cant-Qty-Q.ta										AP 8064									
			1- M26- 2 ST3B										11 - M30- 2H ST3B									
			2- M26- 4 ST3B										12 - M30- 4H ST3B									
3- M30- 2 ST3B										13 - M40- 2H ST3B												
4- M30- 4 ST3B										14 - M40- 4H ST3B												
5- M40- 2 ST3B										15 - M50- 2H ST3B												
6- M40- 4 ST3B										16 - M50- 4H ST3B												
7- M50- 2 ST3B										17 -												
8- M50- 4 ST3B										18 -												
9- M26- 2H ST3B										19 -												
10- M26- 4H ST3B										20 -												
			1	2	3	4	5	6	7	8	9	10	11	12	13	14	15	16	17	18	19	20
1	298453	Moteur complet Motor completo Motore completo - Kompletter motor - Complete engine	1	1	1	1	1	1	1	1	1	1	1	1	1	1	1	1				
2	798622	Tube Tubo Tubo - Rohr - Tube	1	1	1	1	1	1	1	1	1	1	1	1	1	1	1	1				
3	552727	Vis Tornillo Vite - Schraube - Screw	1	1	1	1	1	1	1	1	1	1	1	1	1	1	1	1				
4	797348	Joint torique Junta tórica Anello OR - "0" ring - "0" ring	1	1	1	1	1	1	1	1	1	1	1	1	1	1	1	1				
5	797348	Joint torique Junta tórica Anello OR - "0" ring - "0" ring	1	1	1	1	1	1	1	1	1	1	1	1	1	1	1	1				
6	798634	Vis Tornillo Vite - Schraube - Screw	1	1	1	1	1	1	1	1	1	1	1	1	1	1	1	1				
7	798635	Rondelle Arandela Rondella - Unterlegscheibe - Washer	1	1	1	1	1	1	1	1	1	1	1	1	1	1	1	1				
8	798537	Courroie d'alternateur Correa de alternador Cinghia di alternatore - Wechselstromgeneratorriemen - Alternator belt	1	1	1	1	1	1	1	1	1	1	1	1	1	1	1	1				
9	798540	Goujon Espárrago Prigioniero - Stiftschraube - Stud-bolt	4	4	4	4	4	4	4	4	4	4	4	4	4	4	4	4				
10	798539	Entretoise Separador Distanziale - Querstrebe - Spacer	1	1	1	1	1	1	1	1	1	1	1	1	1	1	1	1				
11	473939	Ecrou Tuerca Dado - Mutter - Nut	4	4	4	4	4	4	4	4	4	4	4	4	4	4	4	4				

M

+

Catalogue : 647483

2	ADAPTATION MOTEUR MOTOR ANPASSUNG ADAPTACION MOTOR ENGINE ADAPTATION ADATTAMENTO MOTORE			Qte-Menge-Cant-Qty-Q.ta										AP 8064									
	Rep Hinw Fig Item Rif	Numéro Teil-Nr Numero Part-Nr Part-Nr	Désignation Bezeichnung Descripcion Description Descrizione	1	2	3	4	5	6	7	8	9	10	11	12	13	14	15	16	17	18	19	20
12	28959	Rondelle M 5 ZN Arandela Rondella	- Unterlegscheibe - Washer	2	2	2	2	2	2	2	2	2	2	2	2	2	2	2	2				
13	54232	Ecrou H ,M 5 ZN Tuerca Dado	- Mutter - Nut	1	1	1	1	1	1	1	1	1	1	1	1	1	1	1	1				
14	25714	Ecrou H ,M 6 ZN Tuerca Dado	- Mutter - Nut	1	1	1	1	1	1	1	1	1	1	1	1	1	1	1	1				
15	29469	Rondelle M 6 ZN Arandela Rondella	- Unterlegscheibe - Washer	2	2	2	2	2	2	2	2	2	2	2	2	2	2	2	2				
16	798640	Patte de fixation Brida de fijación Flangia di fissaggio	- Befestigung auge - Fastening lug	1	1	1	1	1	1	1	1	1	1	1	1	1	1	1	1				
17	473958	Vis 10 x 30 Tornillo Vite	- Schraube - Screw	2	2	2	2	2	2	2	2	2	2	2	2	2	2	2	2				
18	798639	Patte Brida Piastra	- Auge - Lug	1	1	1	1	1	1	1	1	1	1	1	1	1	1	1	1				
19	705398	Vis Tornillo Vite	- Schraube - Screw	2	2	2	2	2	2	2	2	2	2	2	2	2	2	2	2				
20	798703	Jauge Galga Livello	- Eichmass - Gauge	1	1	1	1	1	1	1	1	1	1	1	1	1	1	1	1				
21	797347	Joint torique Junta tórica Anello OR	- "O" ring - "O" ring	1	1	1	1	1	1	1	1	1	1	1	1	1	1	1	1				

M

AP 3244

POUR MOTEUR
FÜR MOTOR
PARA MOTOR
FOR ENGINE
PER MOTORE

□ Type: **JS 71001**
□ Ref: **298 453**

BLOC CYLINDRES
ZYLINDERBLOCK
BLOQUE DE CILINDROS
CYLINDER BLOCK
MONOBLOCCO CILINDRO

M 26-2/4 ST3B
M 30-2/4 ST3B
M 40-2/4 ST3B
M 50-2/4 ST3B

M 26-2/4H ST3B
M 30-2/4H ST3B
M 40-2/4H ST3B
M 50-2/4H ST3B

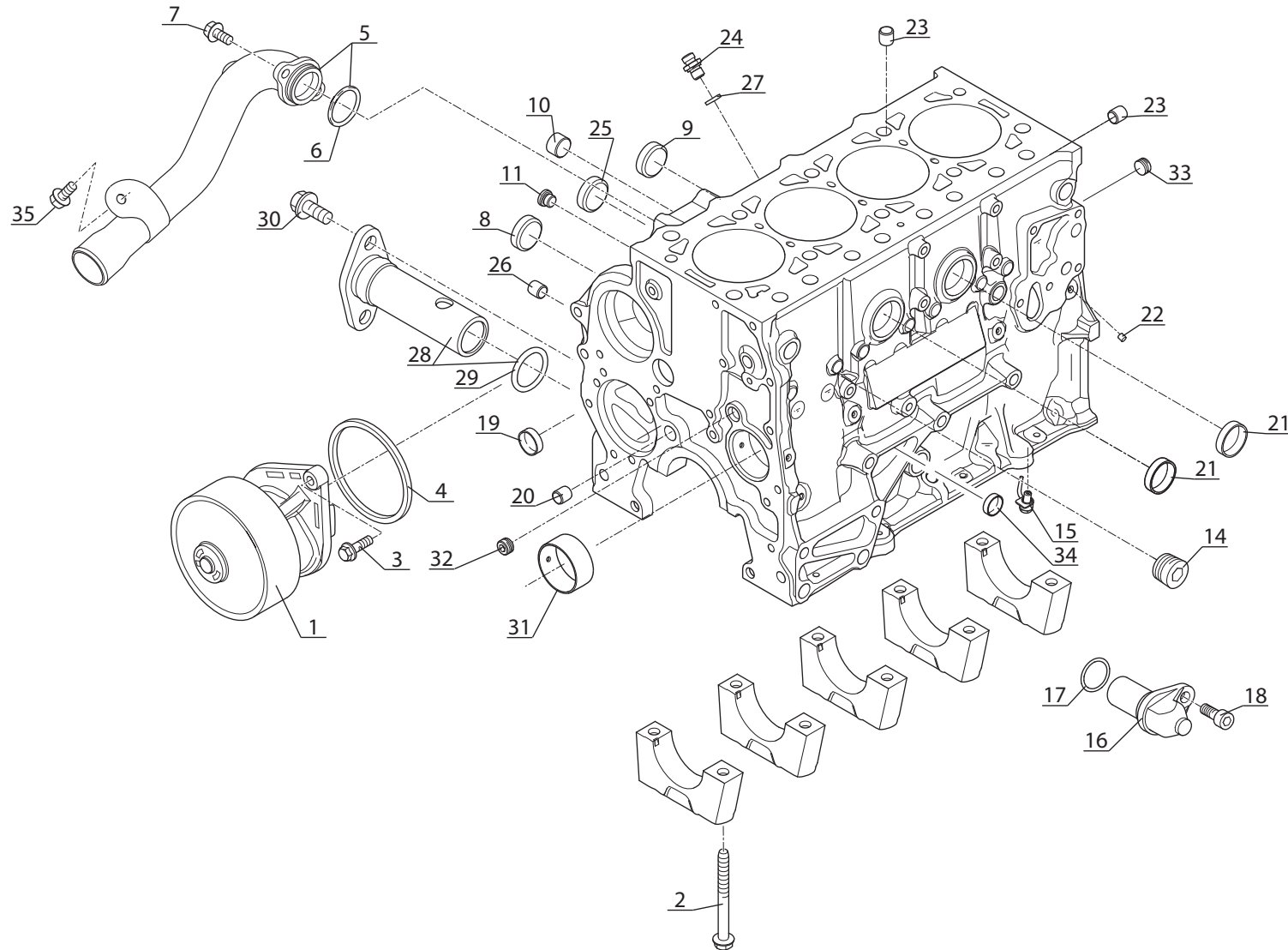

Catalogue : 298453MOD

3	BLOC CYLINDRES ZYLINDERBLOCK BLOQUE DE CILINDROS CYLINDER BLOCK MONOBLOCCO CILINDRO			Qte-Menge-Cant-Qty-Q.ta										AP 3244									
	Rep Hinw Fig Item Rif	Numéro Teil-Nr Numero Part-Nr Part-Nr	Désignation Bezeichnung Descripcion Description Descrizione	1-	2-	3-	4-	5-	6-	7-	8-	9-	10-	11-	12-	13-	14-	15-	16-	17-	18-	19-	20-
30	474018	Vis (6 x 14) Screw	- Schraube - Vite	- Tornillo	2																		
31	797602	Bague Bushing	- Büchse - Anello	- Anillo	1																		
32	797594	Bouchon Plug	- Stopfen - Tappo	- Tapón	1																		
33	797594	Bouchon Plug	- Stopfen - Tappo	- Tapón	2																		
34	797595	Bouchon Plug	- Stopfen - Tappo	- Tapón	1																		
35	797606	Vis Screw	- Schraube - Vite	- Tornillo	1																		

M

Catalogue : 298453MOD

2	PISTONS - BIELLES - VILEBREQUIN KOLBEN - PLEUELSTANGE - KURBELWELLE PISTONES - BIELAS - CIGUENAL PISTONS - CONNECTING RODS - CRANK SHAFT PISTONI - BIELLE - ALBERO A MANOVELLA			Qte-Menge-Cant-Qty-Q.ta										AP 3245									
	Rep Hinw Fig Item Rif	Numéro Teil-Nr Numero Part-Nr Part-Nr	Désignation Bezeichnung Descripcion Description Descrizione	1-	2-	3-	4-	5-	6-	7-	8-	9-	10-	11-	12-	13-	14-	15-	16-	17-	18-	19-	20-
14	797564	Jeu segments piston de piston tiche	- Kolbenringsatz - Kit piston ring	- Juego de segmentos - Kit fascie elas-	1																		
15	797563	Circlips Circlip	- Sicherungsring - Anello elastico	- Aro retén	2																		
16	797567	Jeu de coussinets Bearing kit	- Lagersatz - Kit cuscinetto	- Juego cojinetes	4																		
16	797568	Jeu de coussinets (-0,508 mm) Bearing kit	- Lagersatz - Kit cuscinet	- Juego cojinetes	4																		
16	797569	Jeu de coussinets (-0,254 mm) Bearing kit	- Lagersatz - Kit cuscinet	- Juego cojinetes	4																		
17	798417	Vis Screw	- Schraube - Vite	- Tornillo	6																		

M

AP 3246

POUR MOTEUR
FÜR MOTOR
PARA MOTOR
FOR ENGINE
PER MOTORE

□ Type: JS 71001
□ Ref: 298 453

CULASSE
ZYLINDERKOPF
CULATA
CYLINDER HEAD
TESTATA

M 26-2/4 ST3B M 26-2/4H ST3B
M 30-2/4 ST3B M 30-2/4H ST3B
M 40-2/4 ST3B M 40-2/4H ST3B
M 50-2/4 ST3B M 50-2/4H ST3B

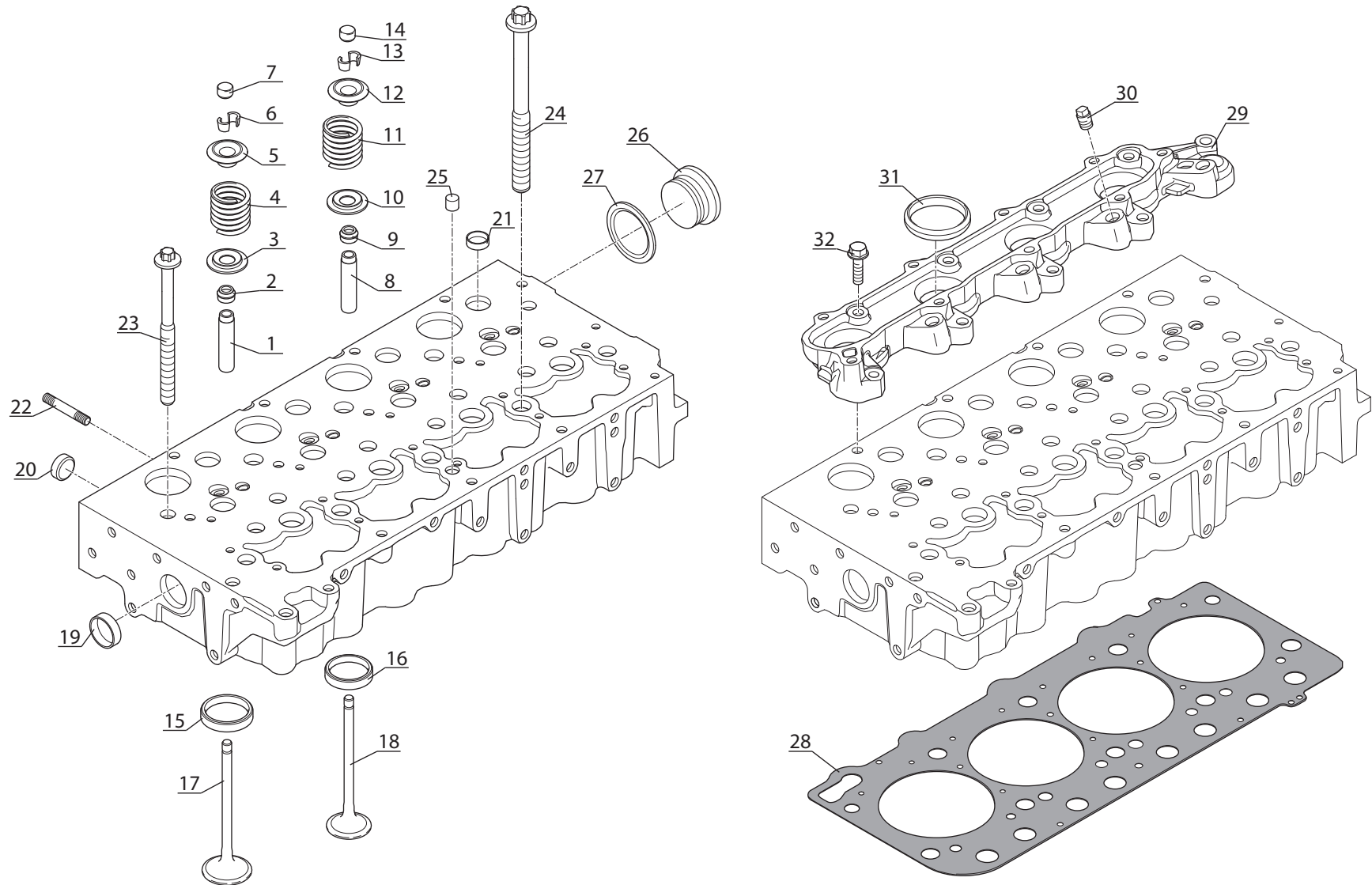

Catalogue : 298453MOD

1	CULASSE ZYLINDERKOPF CULATA CYLINDER HEAD TESTATA			Qte-Menge-Cant-Qty-Q.ta										AP 3246									
	Rep Hinw Fig Item Rif	Numéro Teil-Nr Numero Part-Nr Part-Nr	Désignation Bezeichnung Descripcion Description Descrizione	1	2	3	4	5	6	7	8	9	10	11	12	13	14	15	16	17	18	19	20
0	298453	Moteur complet Complete engine	- Kompletter motor - Motore completo - Motor completo	1																			
1	797576	Guide Guide	- Führungs - Guida	4																			
1	797592	Guide (+0,1 mm) Guide	- Führungs - Guida	4																			
1	797593	Guide (+0,2 mm) Guide	- Führungs - Guida	4																			
2	797339	Joint de tige Rod seal	- Kolbenstangendichtung - Guarnizióne	4																			
3	797582	Siège de ressort Seat spring	- Federteller - Inserto mollo	4																			
4	797583	Ressort de soupape Spring valve	- Ventil feder - Molla di valvola	4																			
5	797584	Siège de ressort Seat spring	- Federteller - Inserto mollo	4																			
6	797585	Demi-lune Cotter	- Splint - Mezza-luna	8																			
7	797586	Chapeau Cap	- Deckel - Capello	4																			
8	797576	Guide Guide	- Führungs - Guida	4																			
8	797592	Guide (+0,1 mm) Guide	- Führungs - Guida	4																			
8	797593	Guide (+0,2 mm) Guide	- Führungs - Guida	4																			
9	797339	Joint de tige Rod seal	- Kolbenstangendichtung - Guarnizióne	4																			

M

+

Catalogue : 298453MOD

2	CULASSE ZYLINDERKOPF CULATA CYLINDER HEAD TESTATA			Qte-Menge-Cant-Qty-Q.ta										AP 3246									
	Rep Hinw Fig Item Rif	Numéro Teil-Nr Numero Part-Nr Part-Nr	Désignation Bezeichnung Descrpcion Description Descrizione	1-	2-	3-	4-	5-	6-	7-	8-	9-	10-	11-	12-	13-	14-	15-	16-	17-	18-	19-	20-
10	797582	Siège de ressort Seat spring	- Federteller - Inserto mollo	- Asiento de muelle	4																		
11	797583	Ressort de soupape Spring valve	- Ventil feder - Molla di valvola	- Resorte de válvula	4																		
12	797584	Siège de ressort Seat spring	- Federteller - Inserto mollo	- Asiento de muelle	4																		
13	797585	Demi-lune Cotter	- Splint - Mezza-luna	- Chaveta	8																		
14	797586	Chapeau Cap	- Deckel - Capello	- Tapadera	4																		
15	797577	Guide(Soupape adm.) Guide (Inlet valve)	- Führungs (Einlassve.) - Guida (Valvola aspir)	- Guía (Valv de adm.)	4																		
16	797578	Guide (Soup d'échappem) Guide (Escape valve)	- Führungs (Auspuffven) - Guida (Valv scarico)	- Guía (Válv de esca)	4																		
17	797581	Soupape admission Inlet valve	- Einlassventil - Valvola aspirazione	- Valvula de admisión	4																		
18	797587	Soupape d'échappement Flusing and boost press. val	- Auspuffventil	- Válvula de escape - Valvola scarico	4																		
19	797550	Bouchon Plug	- Stopfen - Tappo	- Tapón	1																		
20	797579	Bouchon Plug	- Stopfen - Tappo	- Tapón	4																		
21	797580	Bouchon Plug	- Stopfen - Tappo	- Tapón	8																		
22	797590	Goujon Stud-bolt	- Stiftschraube - Prigioniero	- Espárrago	8																		
23	797588	Vis Screw	- Schraube - Vite	- Tornillo	4																		

M

+

Catalogue : 298453MOD

3	CULASSE ZYLINDERKOPF CULATA CYLINDER HEAD TESTATA			Qte-Menge-Cant-Qty-Q.ta										AP 3246									
	Rep Hinw Fig Item Rif	Numéro Teil-Nr Numero Part-Nr Part-Nr	Désignation Bezeichnung Descripcion Description Descrizione	1-	2-	3-	4-	5-	6-	7-	8-	9-	10-	11-	12-	13-	14-	15-	16-	17-	18-	19-	20-
24	797589	Vis Screw	- Schraube - Vite	- Tornillo	6																		
25	797591	Pion Pin	- Stift - Spina	- Espiga	1																		
26	797670	Bouchon Plug	- Stopfen - Tappo	- Tapón	1																		
27	797336	Joint Seal	- Dichtung - Guarnizióne	- Junta	1																		
28	797321	Joint de culas(0,8 mm) Cylinder head gasket	- Zylinderkopfdichtung - Guarnizióne testata	- Junta de culata	1																		
28	797322	Joint de culas(0,7 mm) Cylinder head gasket	- Zylinderkopfdichtung - Guarnizióne testata	- Junta de culata	1																		
29	797616	Adaptateur Adaptor	- Verbindung - Adattatore	- Adaptador	1																		
30	797617	Goujon Stud-bolt	- Stiftschraube - Prigioniero	- Espárrago	4																		
31	797323	Joint torique "O" ring	- "O" ring - Anello OR	- Junta tórica	4																		
32	797618	Vis Screw	- Schraube - Vite	- Tornillo	9																		

M

AP 3247

POUR MOTEUR
FÜR MOTOR
PARA MOTOR
FOR ENGINE
PER MOTORE

□ Type: **JS 71001**
□ Ref: **298 453**

RAMPE DES CULBUTEURS
KIPPEBELWELLE
PERFIL DE BALANCIN
ROCKER ARM SHAFT
ASSE A BILANCIERI

M 26-2/4 ST3B
M 30-2/4 ST3B
M 40-2/4 ST3B
M 50-2/4 ST3B

M 26-2/4H ST3B
M 30-2/4H ST3B
M 40-2/4H ST3B
M 50-2/4H ST3B

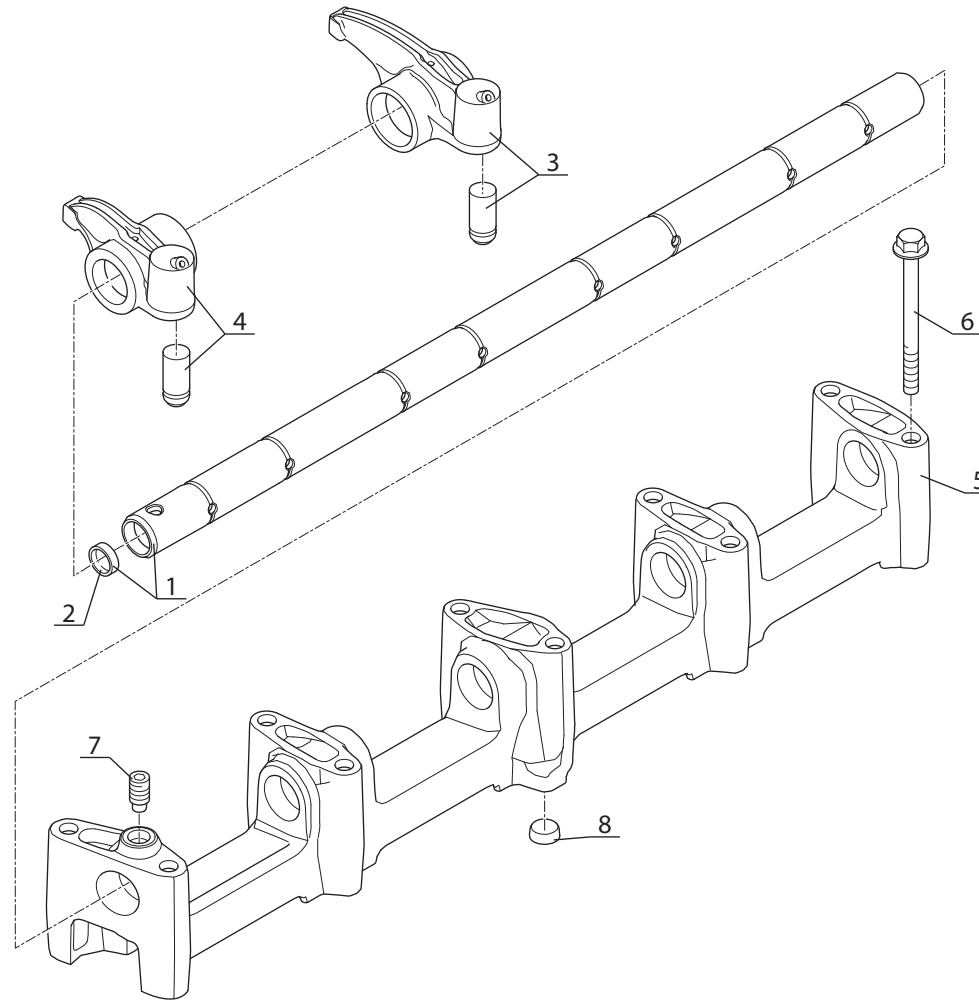

AP 3248

POUR MOTEUR
FÜR MOTOR
PARA MOTOR
FOR ENGINE
PER MOTORE

□ Type: **JS 71001**
□ Ref: **298 453**

DISTRIBUTION ET ARBRE A CAMES
STEUERGETRIEBE UND NOCKENWELLE
DISTRIBUCION Y ARBOL DE LEVAS
TIMING GEAR AND CAMSHAFT
INGRANAGGI E ALBERO DELLA DISTRIBUZIONE

M 26-2/4 ST3B
M 30-2/4 ST3B
M 40-2/4 ST3B
M 50-2/4 ST3B

M 26-2/4H ST3B
M 30-2/4H ST3B
M 40-2/4H ST3B
M 50-2/4H ST3B

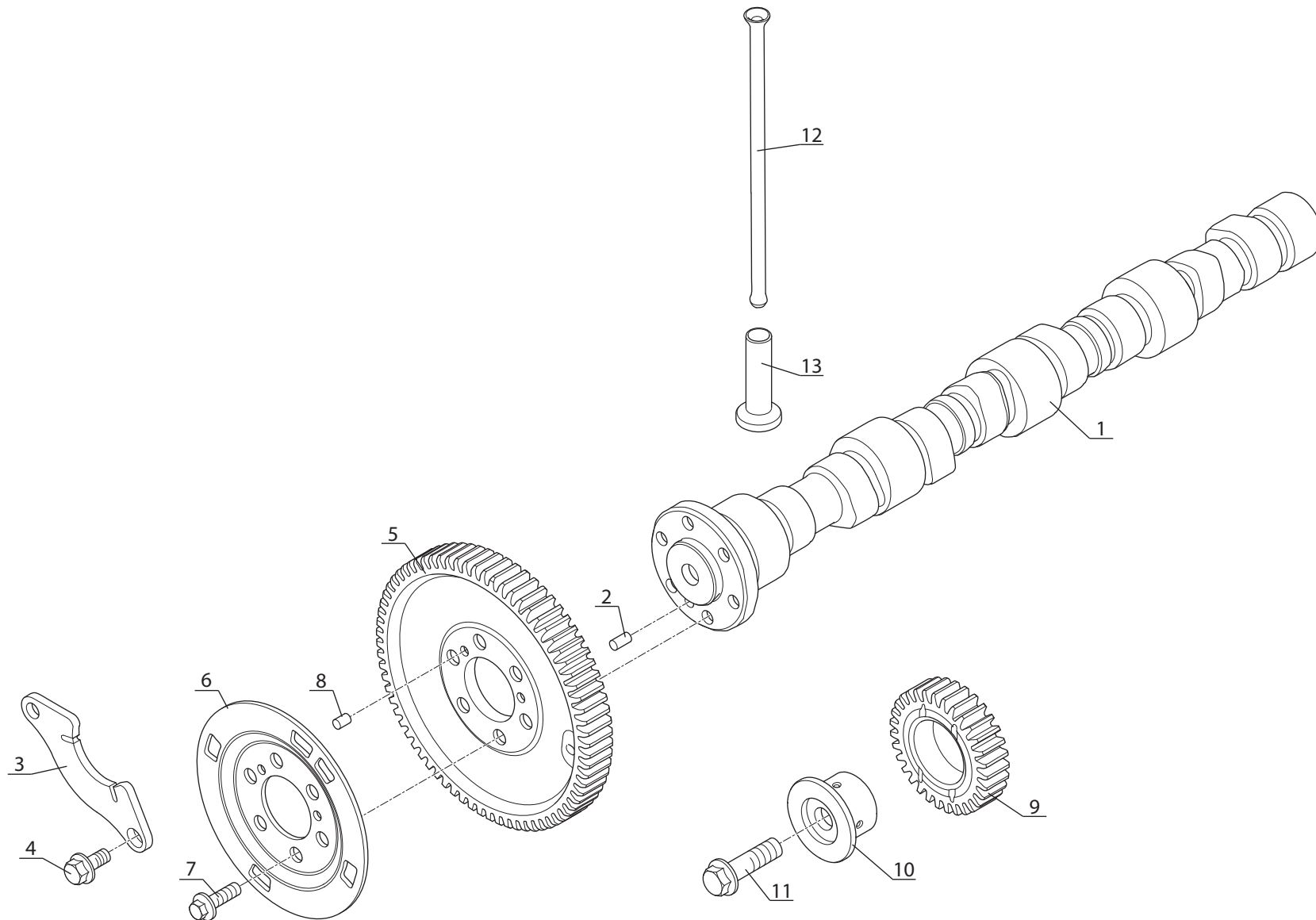

Catalogue : 298453MOD

1	DISTRIBUTION ET ARBRE A CAMES STUERGETRIEBE UND NOCKENWELLE DISTRIBUCION Y ARBOL DE LEVAS TIMING GEAR AND CAMSHAFT INGRANAGGI E ALBERO DELLA DISTRIBUZIONE			Qte-Menge-Cant-Qty-Q.ta										AP 3248									
	Rep Hinw Fig Item Rif	Numéro Teil-Nr Numero Part-Nr Part-Nr	Désignation Bezeichnung Descripcion Description Descrizione	1-	2-	3-	4-	5-	6-	7-	8-	9-	10-	11-	12-	13-	14-	15-	16-	17-	18-	19-	20-
0	298453	Moteur complet Complete engine	- Kompletter motor - Motore completo - Motor completo	1																			
1	797603	Arbre à cames Camshaft	- Nockenwelle - Albero a camme	1																			
2	797604	Pion de centrage Centering pin	- Zentrierstift - Perno di centraggio	1																			
3	797605	Support Bracket	- Halter - Supporto	1																			
4	797606	Vis Screw	- Schraube - Vite	1																			
5	797607	Pignon Gear	- Zahnrad - Ingranaggio	1																			
6	797608	Bride Flange	- Brida - Flangia	1																			
7	473986	Vis (8 x 25) Screw	- Schraube - Vite	6																			
8	797609	Pion de centrage Centering pin	- Zentrierstift - Perno di centraggio	2																			
9	797610	Pignon Gear	- Zahnrad - Ingranaggio	1																			
10	797611	Bague Bushing	- Büchse - Anello	1																			
11	797612	Vis Screw	- Schraube - Vite	1																			
12	797613	Tige de poussoir Push rod	- Stosselstange - Stelo di spintore	8																			
13	797614	Poussoir Tappet	- Stössel - Spintore	8																			

M

+

AP 3249

POUR MOTEUR
FÜR MOTOR
PARA MOTOR
FOR ENGINE
PER MOTORE

□ Type: JS 71001
□ Ref: 298 453

CARTER DE DISTRIBUTION
VERTEILERGEHÄUSE
CARTER DE DISTRIBUCION
TIMING GEAR HOUSING
CARTER DI DISTRIBUZIONE

M 26-2/4 ST3B M 26-2/4H ST3B
M 30-2/4 ST3B M 30-2/4H ST3B
M 40-2/4 ST3B M 40-2/4H ST3B
M 50-2/4 ST3B M 50-2/4H ST3B

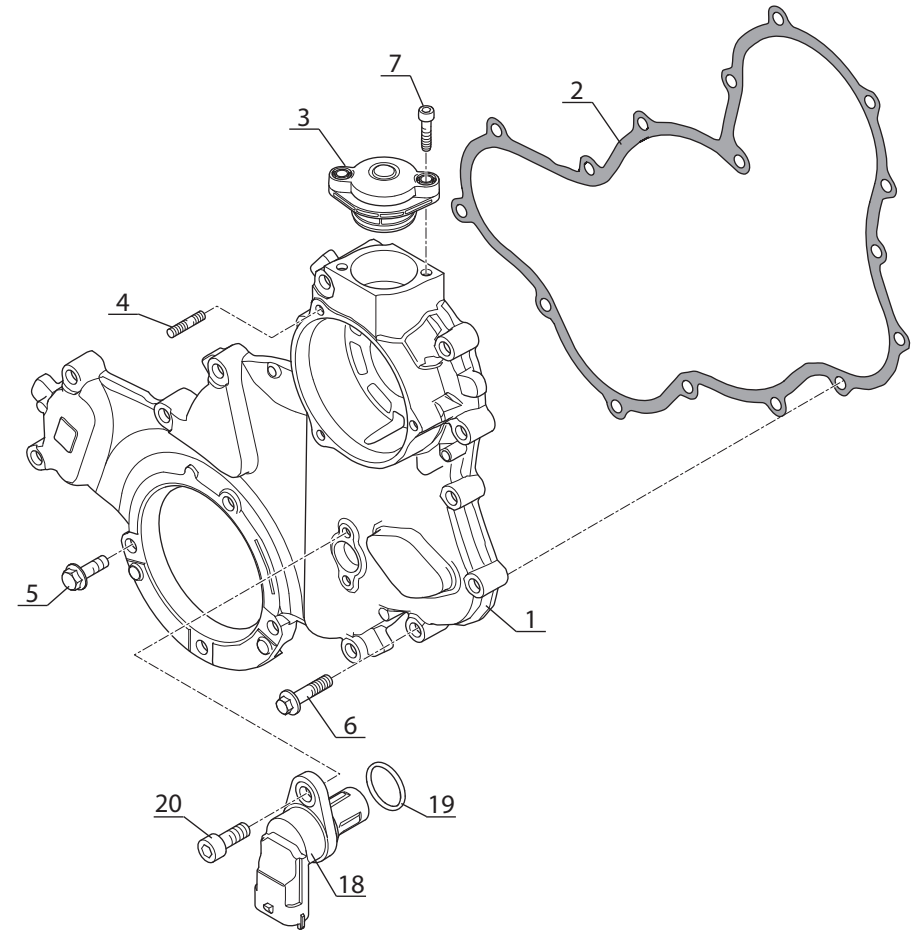
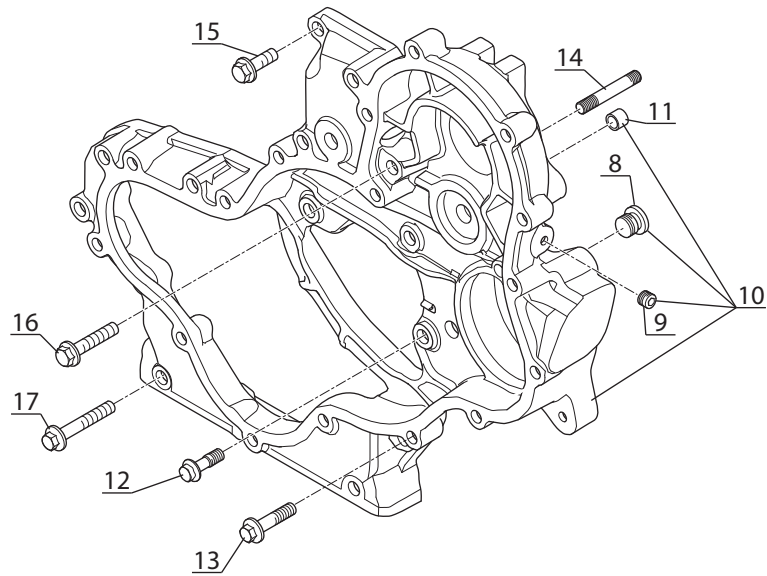

Catalogue : 298453MOD

1		CARTER DE DISTRIBUTION VERTEILERGEHÄUSE CARTER DE DISTRIBUCION TIMING GEAR HOUSING CARTER DI DISTRIBUZIONE			Qte-Menge-Cant-Qty-Q.ta-										AP 3249					M				
Rep Hinw Fig Item Rif	Numéro Teil-Nr Numero Part-Nr Part-Nr	Désignation Bezeichnung Descripcion Descrizione			1-	2-	3-	4-	5-	6-	7-	8-	9-	10-	11 -	12 -	13 -	14 -	15 -	16 -	17 -	18 -	19 -	20 -
				1	2	3	4	5	6	7	8	9	10	11	12	13	14	15	16	17	18	19	20	
0	298453	Moteur complet Complete engine	- Kompletter motor - Motore completo	- Motor completo	1																			
1	798637	Carter de distribution Timing gear housing	- Verteilergehäuse - Carter di distribu.	- Carter de distribu. - Distributietand	1																			
2	797320	Joint d'étanchéité Seal	- Dichtring - Guarnizione di tenuta	- Junta de estanqueid	1																			
3	797686	Soupape Valve	- Ventil - Valvola	- Válvula	1																			
4	797690	Goujon Stud-bolt	- Stiftschraube - Prigioniero	- Espárrago	3																			
5	797636	Vis Screw	- Schraube - Vite	- Tornillo	3																			
6	473951	Vis (8 x 35) Screw	- Schraube - Vite	- Tornillo	13																			
7	797691	Vis Screw	- Schraube - Vite	- Tornillo	2																			
8	797684	Bouchon Plug	- Stopfen - Tappo	- Tapón	1																			
9	797683	Goujon Stud-bolt	- Stiftschraube - Prigioniero	- Espárrago	1																			
10	798636	Carter de distribution Timing gear housing	- Verteilergehäuse - Carter di distribu.	- Carter de distribu.	1																			
11	797591	Pion Pin	- Stift - Spina	- Espiga	2																			
12	797689	Vis Screw	- Schraube - Vite	- Tornillo	3																			
13	473951	Vis (8 x 35) Screw	- Schraube - Vite	- Tornillo	2																			

+

Catalogue : 298453MOD

2	CARTER DE DISTRIBUTION VERTEILERGEHÄUSE CARTER DE DISTRIBUCION TIMING GEAR HOUSING CARTER DI DISTRIBUZIONE			Qte-Menge-Cant-Qty-Q.ta										AP 3249									
	Rep Hinw Fig Item Rif	Numéro Teil-Nr Numero Part-Nr Part-Nr	Désignation Bezeichnung Descripcion Description Descrizione	1-	2-	3-	4-	5-	6-	7-	8-	9-	10-	11-	12-	13-	14-	15-	16-	17-	18-	19-	20-
14	797687	Goujon Stud-bolt	- Stiftschraube - Prigioniero	- Espárrago	3																		
15	797636	Vis Screw	- Schraube - Vite	- Tornillo	1																		
16	474028	Vis (8 x 50) Screw	- Schraube - Vite	- Tornillo	1																		
17	797688	Vis Screw	- Schraube - Vite	- Tornillo	7																		
18	797363	Capteur de vitesse Speed sensor	- Geschwindig keit sen - Sónda di velocità	- Sensor de velocidad	1																		
19	797625	Joint torique "O" ring	- "O" ring - Anello OR	- Junta tórica	1																		
20	797623	Vis Screw	- Schraube - Vite	- Tornillo	1																		

M

AP 3250

POUR MOTEUR
FÜR MOTOR
PARA MOTOR
FOR ENGINE
PER MOTORE

□ Type: **JS 71001**
□ Ref: **298 453**

CARTER D' HUILE - POMPE A HUILE
OLWANNE - SCHMIEROLPUMPE
CARTER DE ACEITE - BOMBA DE ACEITE
OIL SUMP - LUBRICATING OIL PUMP
COPPA OLIO - POMPA LUBRIFICAZIONE

M 26-2/4 ST3B
M 30-2/4 ST3B
M 40-2/4 ST3B
M 50-2/4 ST3B

M 26-2/4H ST3B
M 30-2/4H ST3B
M 40-2/4H ST3B
M 50-2/4H ST3B

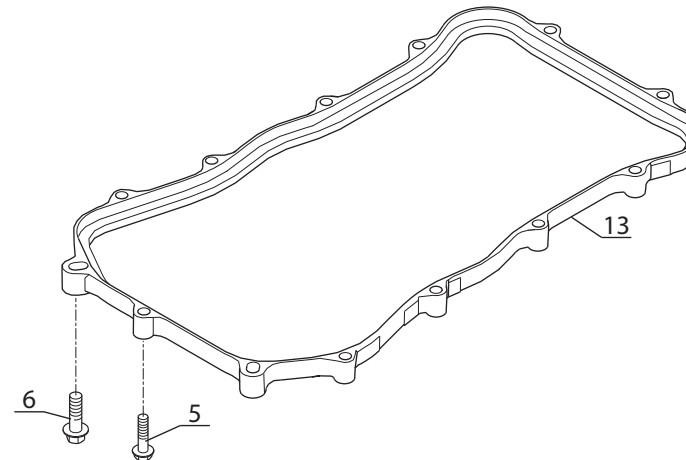
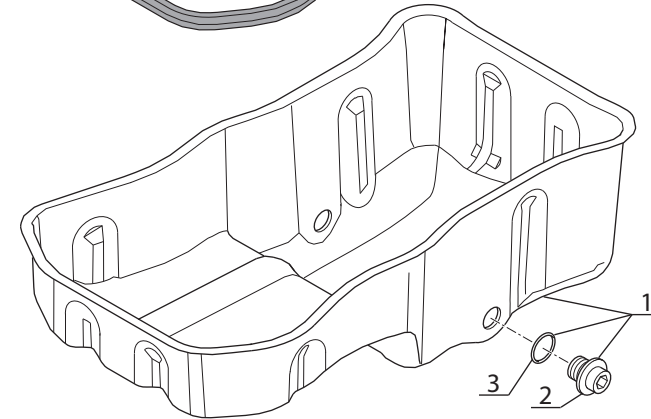
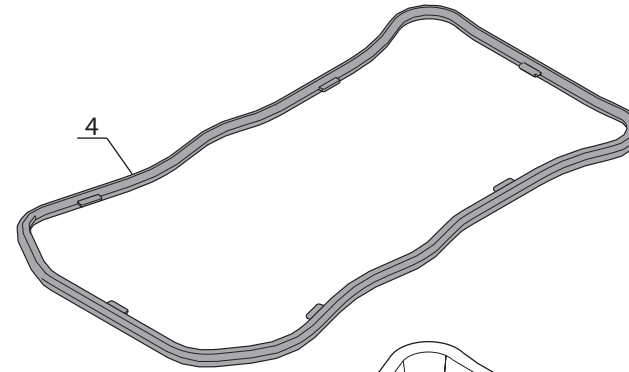
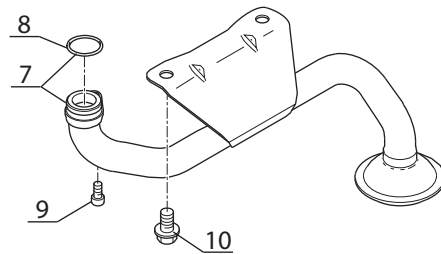
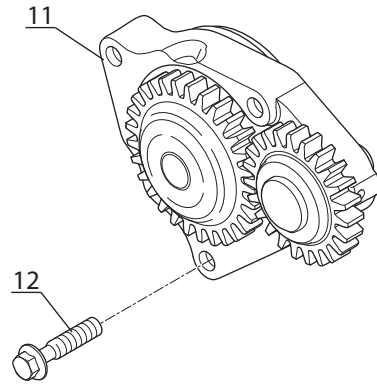

Catalogue : 298453MOD

1 CARTER D' HUILE - POMPE A HUILE OLWANNE - SCHMIEROLPUMPE CARTER DE ACEITE - BOMBA DE ACEITE OIL SUMP - LUBRICATING OIL PUMP COPPA OLIO - POMPA				Qte-Menge-Cant-Qty-Q.ta										AP 3250										
				1- 298453MOD 11 - 2- 12 - 3- 13 - 4- 14 - 5- 15 - 6- 16 - 7- 17 - 8- 18 - 9- 19 - 10- 20 -																				
Rep Hinw Fig Item Rif	Numéro Teil-Nr Numero Part-Nr Part-Nr	Désignation Bezeichnung Descripcion Description Descrizione			1	2	3	4	5	6	7	8	9	10	11	12	13	14	15	16	17	18	19	20
0	298453	Moteur complet Complete engine	- Kompletter motor - Motore completo	- Motor completo	1																			
1	798413	Carter d'huile Oil sump	- Olwanne - Carter d'olio	- Carter de aceite	1																			
2	797644	Bouchon de vidange Drain plug	- Ablasschraube - Tappo di scarico	- Tapón de vaciado	1																			
3	797342	Joint Seal	- Dichtung - Guarnizióne	- Junta	1																			
4	798414	Joint d'étanchéité Seal	- Dichtring - Guarnizi di tenuta	- Junta de estanqueid	1																			
5	473951	Vis (8 x 35) Screw	- Schraube - Vite	- Tornillo	11																			
6	473290	Vis Screw	- Schraube - Vite	- Tornillo	2																			
7	798416	Pipe d'aspiration Suction pipe	- Saugleitung - Tubo di aspirazione	- Tubo de aspiración	1																			
8	797350	Joint torique "O" ring	- "O" ring - Anello OR	- Junta tórica	1																			
9	797646	Vis Screw	- Schraube - Vite	- Tornillo	1																			
10	798417	Vis Screw	- Schraube - Vite	- Tornillo	2																			
11	797692	Pompe à huile Lubricating oil pump	- Schmierölpumpe - Pompa lubrificazione	- Bomba de aceite	1																			
12	797693	Vis Screw	- Schraube - Vite	- Tornillo	3																			
13	798415	Plaque de fixation Fastening plate	- Befestigung Platte - Piastra di fissaggio	- Placa de fijación	1																			

AP 3251

POUR MOTEUR
FÜR MOTOR
PARA MOTOR
FOR ENGINE
PER MOTORE

□ Type: **JS 71001**
□ Ref: **298 453**

CACHE CULBUTEUR ET RENIFLARD
KIPPHEBELDECKEL UND ENTLÜFTERROHR
TAPA DE BALANCIN Y RESPIRADERO
ROCKER LEVER COVER AND BREATHER
PARA-BILANCIERE E SFIATATOIO

M 26-2/4 ST3B
M 30-2/4 ST3B
M 40-2/4 ST3B
M 50-2/4 ST3B

M 26-2/4H ST3B
M 30-2/4H ST3B
M 40-2/4H ST3B
M 50-2/4H ST3B

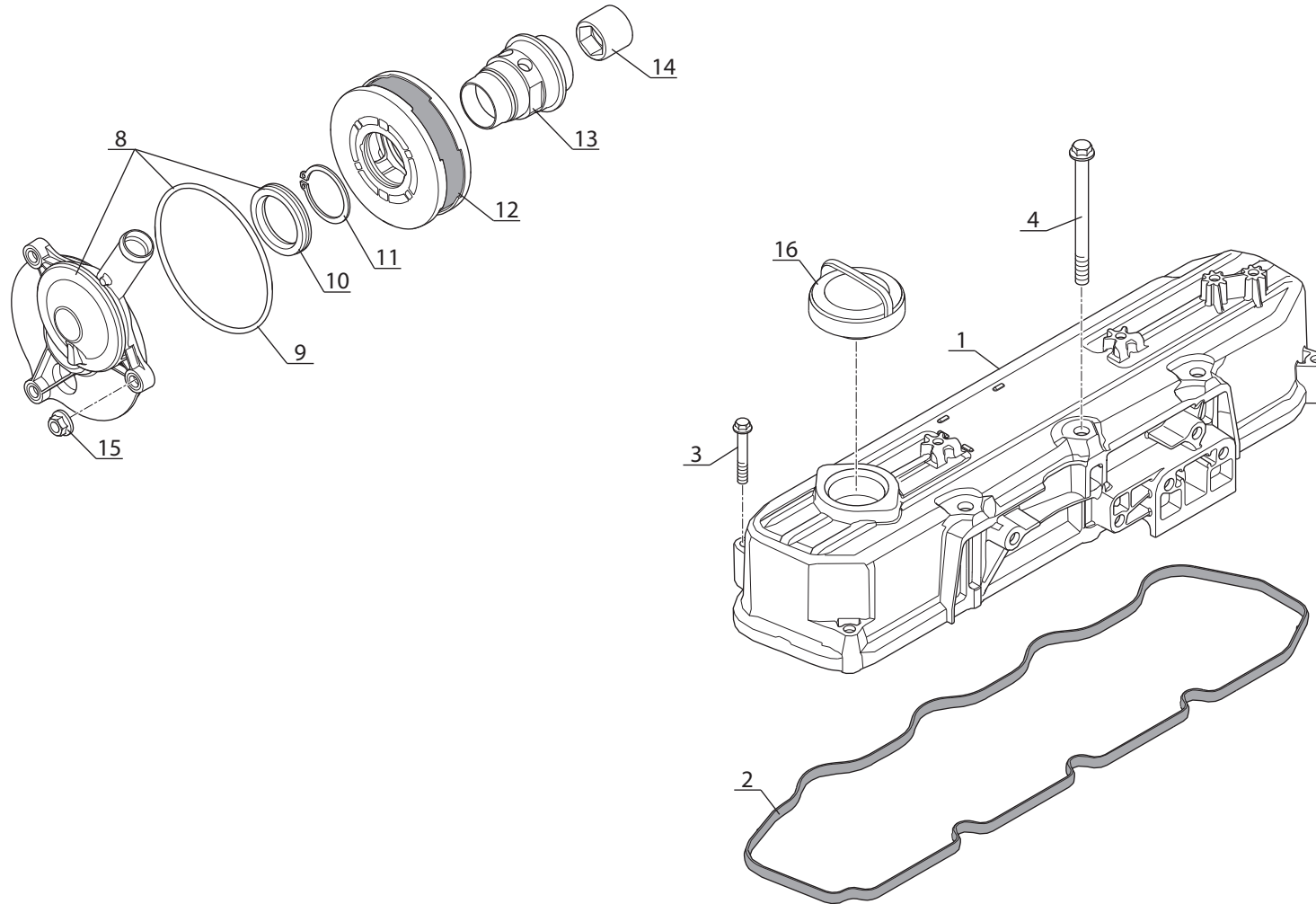

Catalogue : 298453MOD

Rep Hinw Fig Item Rif	Numéro Teil-Nr Numero Part-Nr Part-Nr	Désignation Bezeichnung Descripcion Description Descrizione	Qte-Menge-Cant-Qty-Q.ta										AP 3251									
			1	2	3	4	5	6	7	8	9	10	11	12	13	14	15	16	17	18	19	20
2		CACHE CULBUTEUR ET RENIFLARD KIPPHEBELDECKEL UND ENTLÜFTERROHR TAPA DE BALANCIN Y RESPIRADERO ROCKER LEVER COVER AND BREATHER PARA-BILANCIERE E SFIATATOIO	1- 298453MOD 11 - 2- 12 - 3- 13 - 4- 14 - 5- 15 - 6- 16 - 7- 17 - 8- 18 - 9- 19 - 10- 20 -																			
16	798420	Bouchon de remplissage - Einfüllverschluss - Tapón de llenado Filling plug - Tappo di riempimento	1																			

M

AP 3252

POUR MOTEUR
FÜR MOTOR
PARA MOTOR
FOR ENGINE
PER MOTORE

Type: **JS 71001**
 Ref: **298 453**

FILTRE A HUILE ET REFROIDISSEUR D' HUILE
SCHMIER ÖLFILTER UND MOTORSEITIGER ÖLKÜHLER
FILTRO Y ENFRIADOR INTEGRAL
LUBRICATING OIL FILTER AND INTEGRAL OIL COOLER
FILTRO OLIO E REFRIGERATORE

M 26-2/4 ST3B
M 30-2/4 ST3B
M 40-2/4 ST3B
M 50-2/4 ST3B

M 26-2/4H ST3B
M 30-2/4H ST3B
M 40-2/4H ST3B
M 50-2/4H ST3B

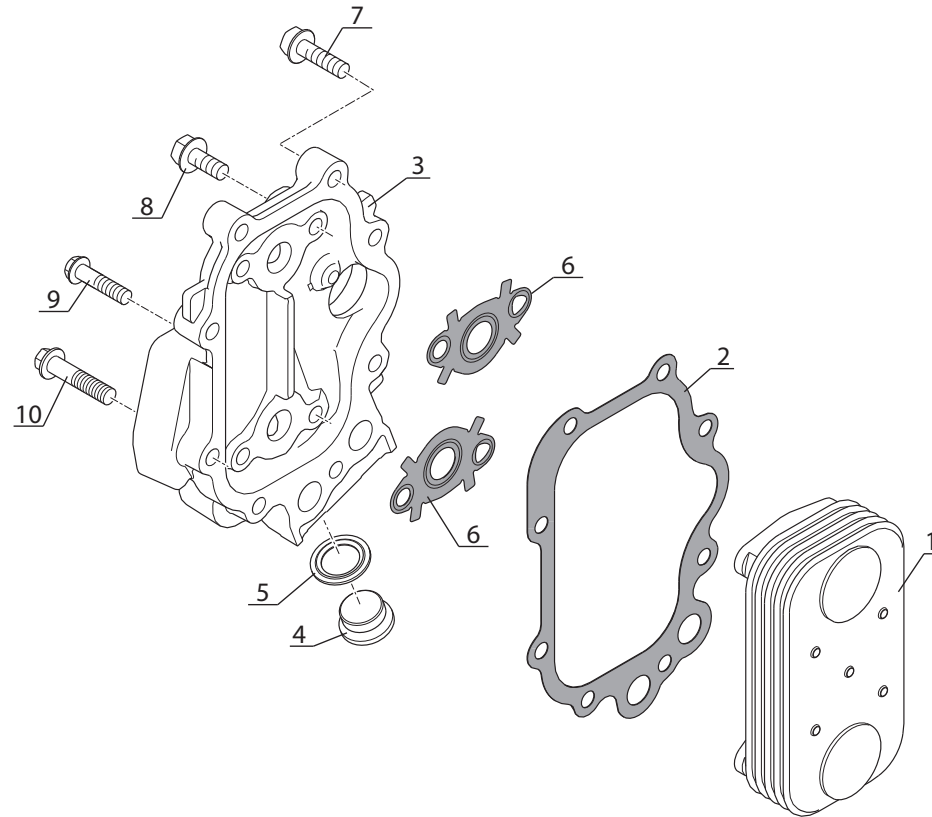

Catalogue : 298453MOD

1	FILTRE A HUILE ET REFROIDISSEUR D' HUILE SCHMIER ÖLFILTER UND MOTORSEITIGER ÖLKHLE FILTRO Y ENFRIADOR INTEGRAL LUBRICATING OIL FILTER AND INTEGRAL OIL COOLER FILTRO OLIO E REFRIGERATORE			Qte-Menge-Cant-Qty-Q.ta										AP 3252									
	Rep Hinw Fig Item Rif	Numéro Teil-Nr Numero Part-Nr Part-Nr	Désignation Bezeichnung Descripcion Description Descrizione	Beschrijving Kuvaus	1-	2-	3-	4-	5-	6-	7-	8-	9-	10-	11-	12-	13-	14-	15-	16-	17-	18-	19-
0	298453	Moteur complet Complete engine	- Kompletter motor - Motore completo	- Motor completo	1																		
1	797656	Refroidisseur d'huile Oil cooler	- Olkühler - Refrigerat integrale	- Enfriador de aceite	1																		
2	798422	Joint plat Gasket	- Dichtung - Guarnizióne	- Junta plana	1																		
3	798421	Support Bracket	- Halter - Supporto	- Soporte	1																		
4	797729	Bouchon Plug	- Stopfen - Tappo	- Tapón	2																		
5	797728	Joint Seal	- Dichtung - Guarnizióne	- Junta	2																		
6	797333	Joint plat Gasket	- Dichtung - Guarnizióne	- Junta plana	2																		
7	797618	Vis Screw	- Schraube - Vite	- Tornillo	7																		
8	797633	Vis Screw	- Schraube - Vite	- Tornillo	2																		
9	473951	Vis (8 x 35) Screw	- Schraube - Vite	- Tornillo	2																		
10	797688	Vis Screw	- Schraube - Vite	- Tornillo	1																		

M

+

AP 3253

POUR MOTEUR
FÜR MOTOR
PARA MOTOR
FOR ENGINE
PER MOTORE

Type: **JS 71001**
 Ref: **298 453**

SONDE DE PRESSION
DRUCKSENSOR
SENSOR DE PRESION
PRESSURE SENSOR
SENSORE DI PRESSIONE

M 26-2/4 ST3B
M 30-2/4 ST3B
M 40-2/4 ST3B
M 50-2/4 ST3B

M 26-2/4H ST3B
M 30-2/4H ST3B
M 40-2/4H ST3B
M 50-2/4H ST3B

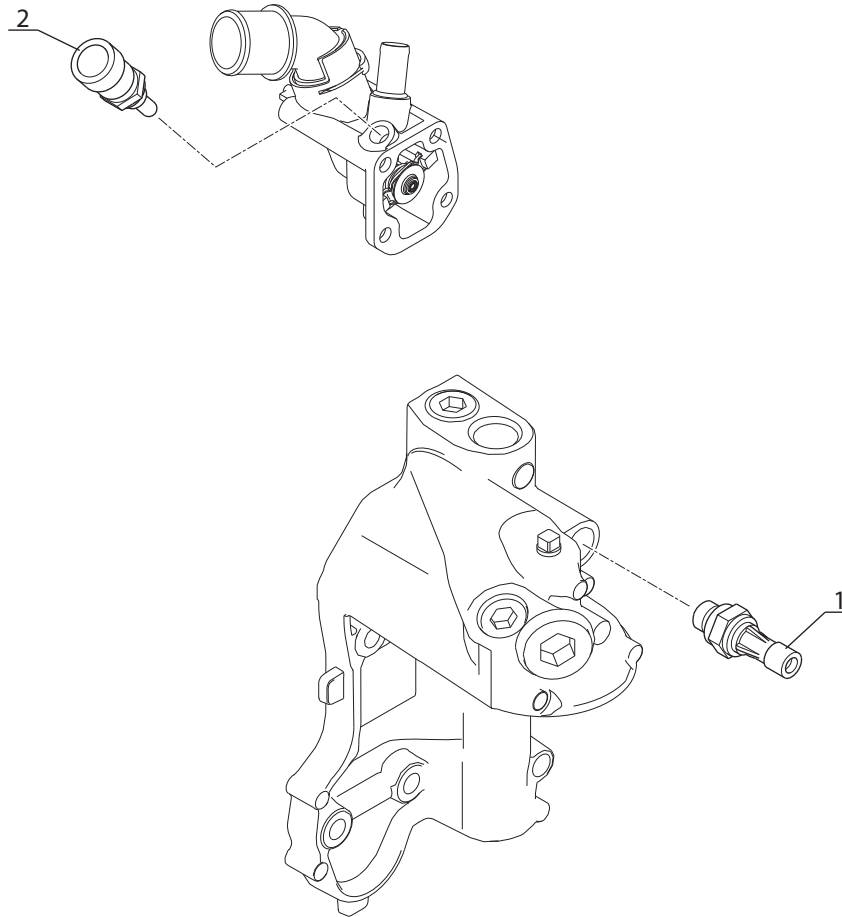

Catalogue : 298453MOD

1	SONDE DE PRESSION DRUCKSENSOR SENSOR DE PRESION PRESSURE SENSOR SENSORE DI PRESSIONE			Qte-Menge-Cant-Qty-Q.ta										AP 3253									
	Rep Hinw Fig Item Rif	Numéro Teil-Nr Numero Part-Nr Part-Nr	Désignation Bezeichnung Descripcion Description Descrizione	1-	2-	3-	4-	5-	6-	7-	8-	9-	10-	11-	12-	13-	14-	15-	16-	17-	18-	19-	20-
0	298453	Moteur complet Complete engine	- Kompletter motor - Motore completo	- Motor completo	1																		
1	797369	Sonde de press d'huile aceite olio	- Oldruck transmitter - Oil pressure sensor - Oliedruksensor	- Sonda de presión de - Sonda de pressione	1																		
2	797357	Sonde de température Temperature sensor	- Temperatur transmitt. - Sonda di temperatura	- Sonda de temperat.	1																		

M

AP 3254

POUR MOTEUR
FÜR MOTOR
PARA MOTOR
FOR ENGINE
PER MOTORE

□ Type: **JS 71001**
□ Ref: **298 453**

THERMOSTAT
THERMOSTAT
TERMOSTATO
THERMOSTAT
TERMOSTATO

M 26-2/4 ST3B
M 30-2/4 ST3B
M 40-2/4 ST3B
M 50-2/4 ST3B

M 26-2/4H ST3B
M 30-2/4H ST3B
M 40-2/4H ST3B
M 50-2/4H ST3B

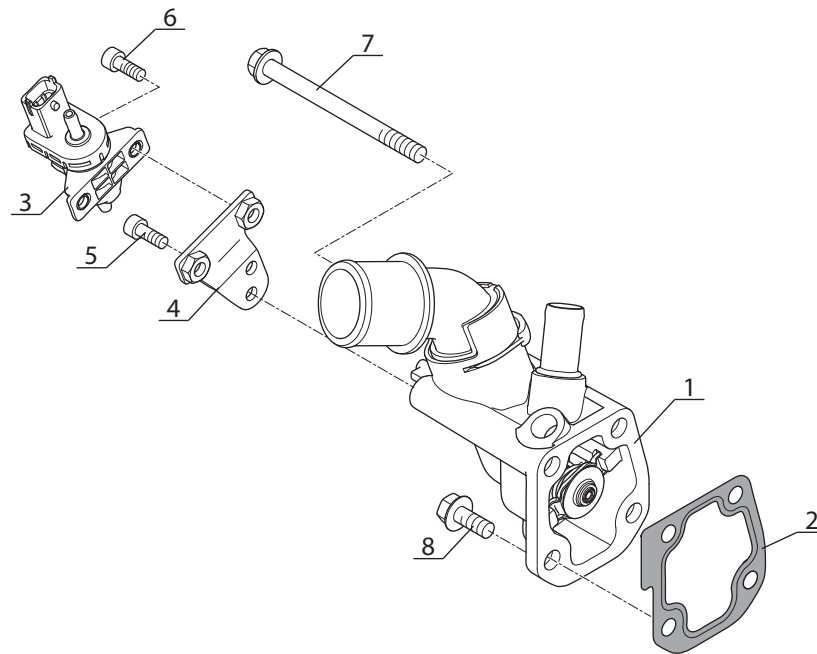

AP 3255

POUR MOTEUR
FÜR MOTOR
PARA MOTOR
FOR ENGINE
PER MOTORE

□ Type: **JS 71001**
□ Ref: **298 453**

COLLECTEUR D' ECHAPPEMENT
AUSPUFFSAMMELROHR
COLECTOR DE ESCAPE
EXHAUST MANIFOLD
COLLETORE DI SCARICO

M 26-2/4 ST3B
M 30-2/4 ST3B
M 40-2/4 ST3B
M 50-2/4 ST3B

M 26-2/4H ST3B
M 30-2/4H ST3B
M 40-2/4H ST3B
M 50-2/4H ST3B

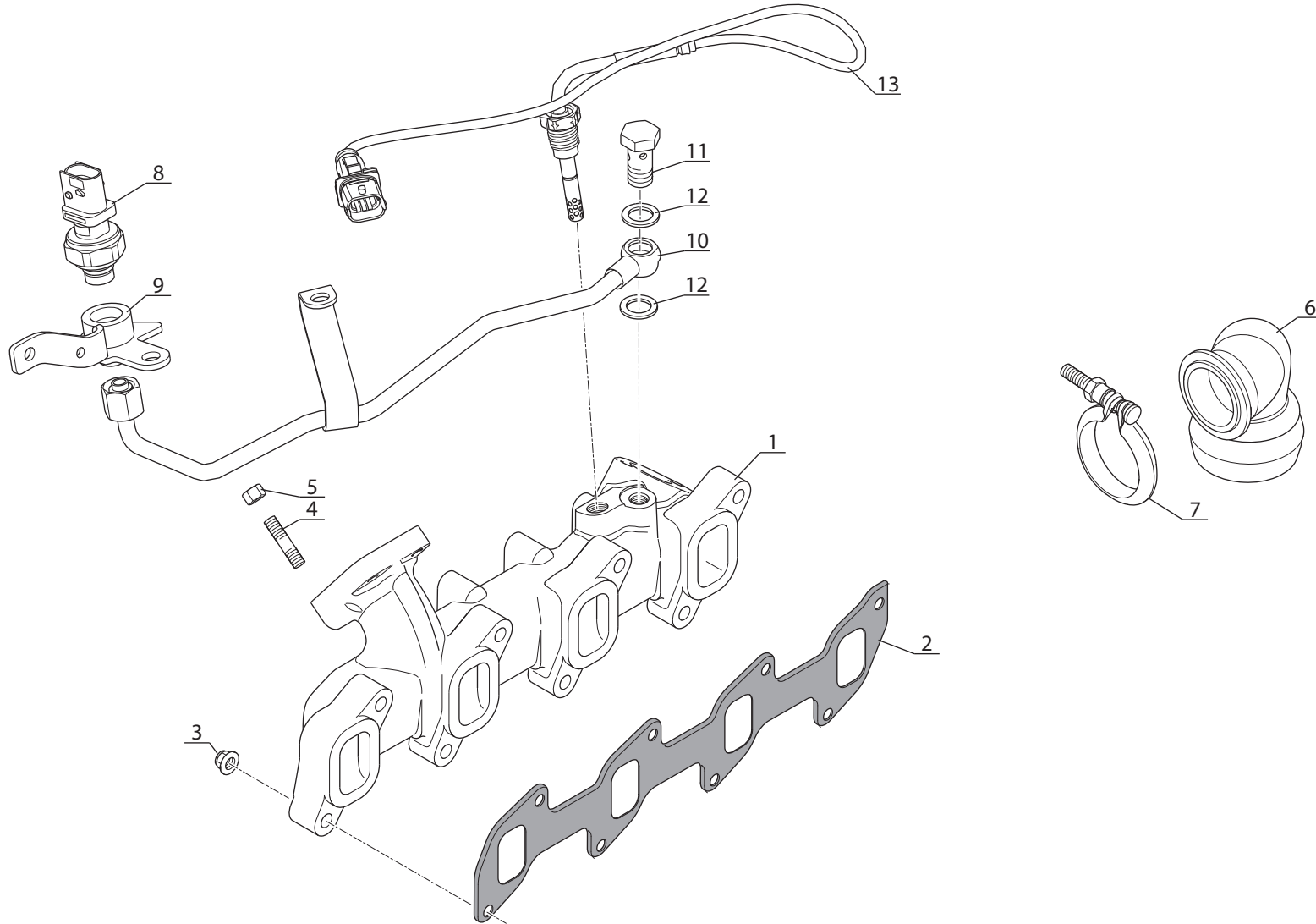

AP 3256

POUR MOTEUR
FÜR MOTOR
PARA MOTOR
FOR ENGINE
PER MOTORE

□ Type: JS 71001
□ Ref: 298 453

FILTRE À PARTICULES D'ÉCHAPPEMENT
RUBPARTIKELFILTER
FILTRO DE PARTICULAS
EXHAUST PARTICULATE FILTER
FILTRA ANTIPARTICULTO DI SCARICO

M 26-2/4 ST3B
M 30-2/4 ST3B
M 40-2/4 ST3B
M 50-2/4 ST3B

M 26-2/4H ST3B
M 30-2/4H ST3B
M 40-2/4H ST3B
M 50-2/4H ST3B

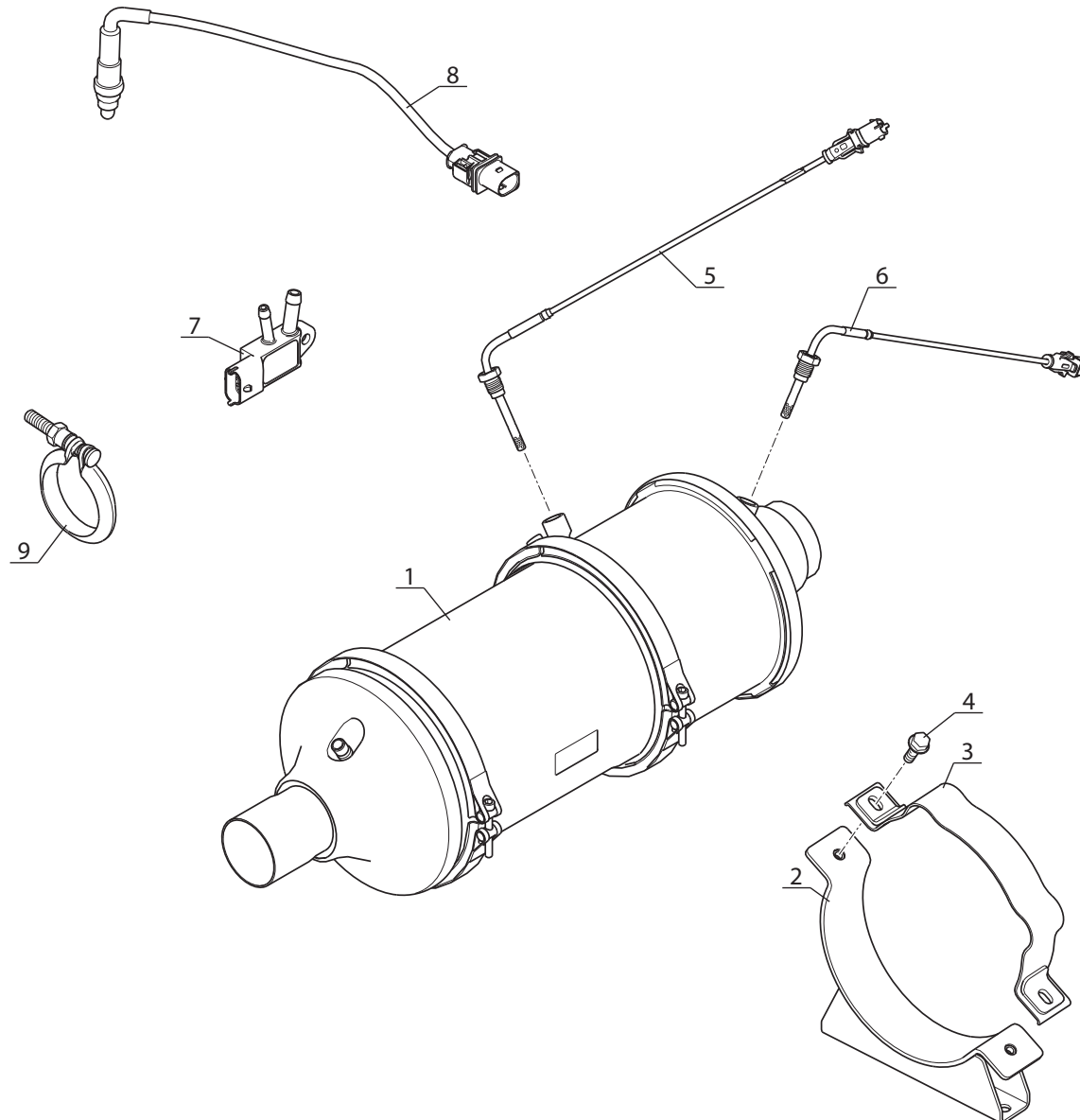

Catalogue : 298453MOD

1	FILTRE À PARTICULES D'ÉCHAPPEMENT RUBPARTIKELFILTER FILTRO DE PARTICULAS EXHAUST PARTICULATE FILTER FILTRA ANTIPARTICULTO DI SCARICO			Qte-Menge-Cant-Qty-Q.ta										AP 3256									
	Rep Hinw Fig Item Rif	Numéro Teil-Nr Numero Part-Nr Part-Nr	Désignation Bezeichnung Descripcion Description Descrizione	1-	2-	3-	4-	5-	6-	7-	8-	9-	10-	11-	12-	13-	14-	15-	16-	17-	18-	19-	20-
				1	2	3	4	5	6	7	8	9	10	11	12	13	14	15	16	17	18	19	20
1	798642	Filtre à particules d'échappement Filtro de particulas Filtra antiparticulto di scarico	- Rubpartikelfilter - Exhaust particulate filter	1																			
2	797721	Support Bracket	- Halter - Supporto	- Soporte	2																		
3	797722	Support Bracket	- Halter - Supporto	- Soporte	2																		
4	797636	Vis Screw	- Schraube - Vite	- Tornillo	4																		
5	797360	Sonde de température Temperature sensor	- Temperatur transmit. - Sonda di temperatura	- Sonda de temperat.	1																		
6	797359	Sonde de température Temperature sensor	- Temperatur transmit. - Sonda di temperatura	- Sonda de temperat.	1																		
7	797362	Capteur Sensor	- Sensor - Sonda	- Sensor	1																		
8	797361	Sonde Sensor	- Transmitter - Sonda	- Sonda	1																		
9	797719	Collier Clamp	- Spannschelle - Fascetta	- Abrazadera	2																		

M

+

AP 3257

POUR MOTEUR
FÜR MOTOR
PARA MOTOR
FOR ENGINE
PER MOTORE

□ Type: JS 71001
□ Ref: 298 453

COLLECTEUR D'ADMISSION
ANSAUGLEITUNG
COLECTOR DE ADMISION
INTAKE MANIFOLD
COLLETTORE DI AMMISSIONE

M 26-2/4 ST3B	M 26-2/4H ST3B
M 30-2/4 ST3B	M 30-2/4H ST3B
M 40-2/4 ST3B	M 40-2/4H ST3B
M 50-2/4 ST3B	M 50-2/4H ST3B

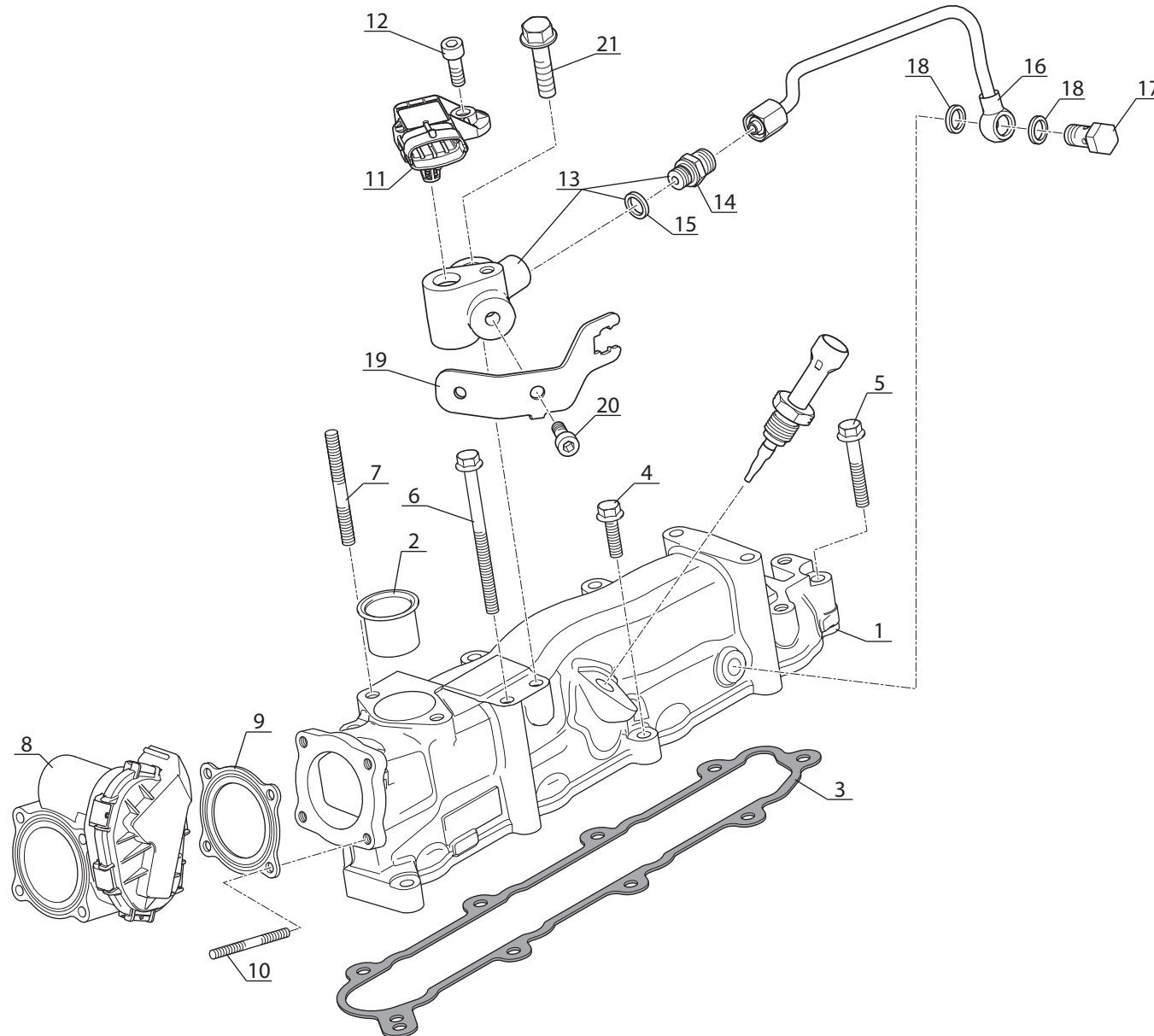

Catalogue : 298453MOD

1	COLLECTEUR D'ADMISSION ANSAUGLEITUNG COLECTOR DE ADMISION INTAKE MANIFOLD COLLETTORE DI AMMISSIONE			Qte-Menge-Cant-Qty-Q.ta										AP 3257									
	Rep Hinw Fig Item Rif	Numéro Teil-Nr Numero Part-Nr Part-Nr	Désignation Bezeichnung Descripcion Description Descrizione	1-	2-	3-	4-	5-	6-	7-	8-	9-	10-	11-	12-	13-	14-	15-	16-	17-	18-	19-	20-
1	798693	Collecteur d'admission Intake manifold	- Ansaugleitung - Collettore di ammiss	- Colector de admisi.	1																		
2	797725	Raccord Adapteur Connection	- Verschraubung - Raccordo	- Racor	1																		
3	797325	Joint plat Gasket	- Dichtung - Guarnizióne	- Junta plana	1																		
4	797618	Vis Screw	- Schraube - Vite	- Tornillo	2																		
5	797688	Vis Screw	- Schraube - Vite	- Tornillo	2																		
6	775835	Vis Screw	- Schraube - Vite	- Tornillo	5																		
7	797703	Goujon Stud-bolt	- Stiftschraube - Prigioniero	- Espárrago	2																		
8	797704	Valve Valve	- Ventil - Valvola	- Válvula	1																		
9	797326	Joint plat Gasket	- Dichtung - Guarnizióne	- Junta plana	1																		
10	797705	Goujon Stud-bolt	- Stiftschraube - Prigioniero	- Espárrago	2																		
11	797365	Sonde de press. d'air Pressure sensor	- Drucksensor - Sensore di pressione	- Sensor de presion	1																		
12	797623	Vis Screw	- Schraube - Vite	- Tornillo	1																		
13	798697	Support Bracket	- Halter - Supporto	- Soporte	1																		
14	798698	Raccord Union Connection	- Verschraubung - Raccordo	- Racor	1																		

M

+

Catalogue : 298453MOD

2	COLLECTEUR D'ADMISSION ANSAUGLEITUNG COLECTOR DE ADMISION INTAKE MANIFOLD COLLETTORE DI AMMISSIONE			Qte-Menge-Cant-Qty-Q.ta										AP 3257									
	Rep Hinw Fig Item Rif	Numéro Teil-Nr Numero Part-Nr Part-Nr	Désignation Bezeichnung Descripcion Description Descrizione	1	2	3	4	5	6	7	8	9	10	11	12	13	14	15	16	17	18	19	20
15	798699	Rondelle Washer	- Unterlegscheibe - Rondella	- Arandela	1																		
16	798700	Tube Tube	- Rohr - Tubo	- Tubo	1																		
17	798701	Vis creuse Hollow screw	- Hohlschraube - Vite cava	- Tornillo hueco	1																		
18	798699	Rondelle Washer	- Unterlegscheibe - Rondella	- Arandela	2																		
19	798702	Support Bracket	- Halter - Supporto	- Soporte	1																		
20	797673	Vis Screw	- Schraube - Vite	- Tornillo	1																		
21	797618	Vis Screw	- Schraube - Vite	- Tornillo	1																		

M

AP 3258

POUR MOTEUR
FÜR MOTOR
PARA MOTOR
FOR ENGINE
PER MOTORE

□ Type: **JS 71001**
□ Ref: **298 453**

MÉLANGEUR
MISCHER
MEZCLADOR
MIXER
MISCELATORE

M 26-2 ST3B
M 26-4 ST3B
M 30-2 ST3B
M 30-4 ST3B

M 40-2 ST3B
M 40-4 ST3B
M 50-2 ST3B
M 50-4 ST3B

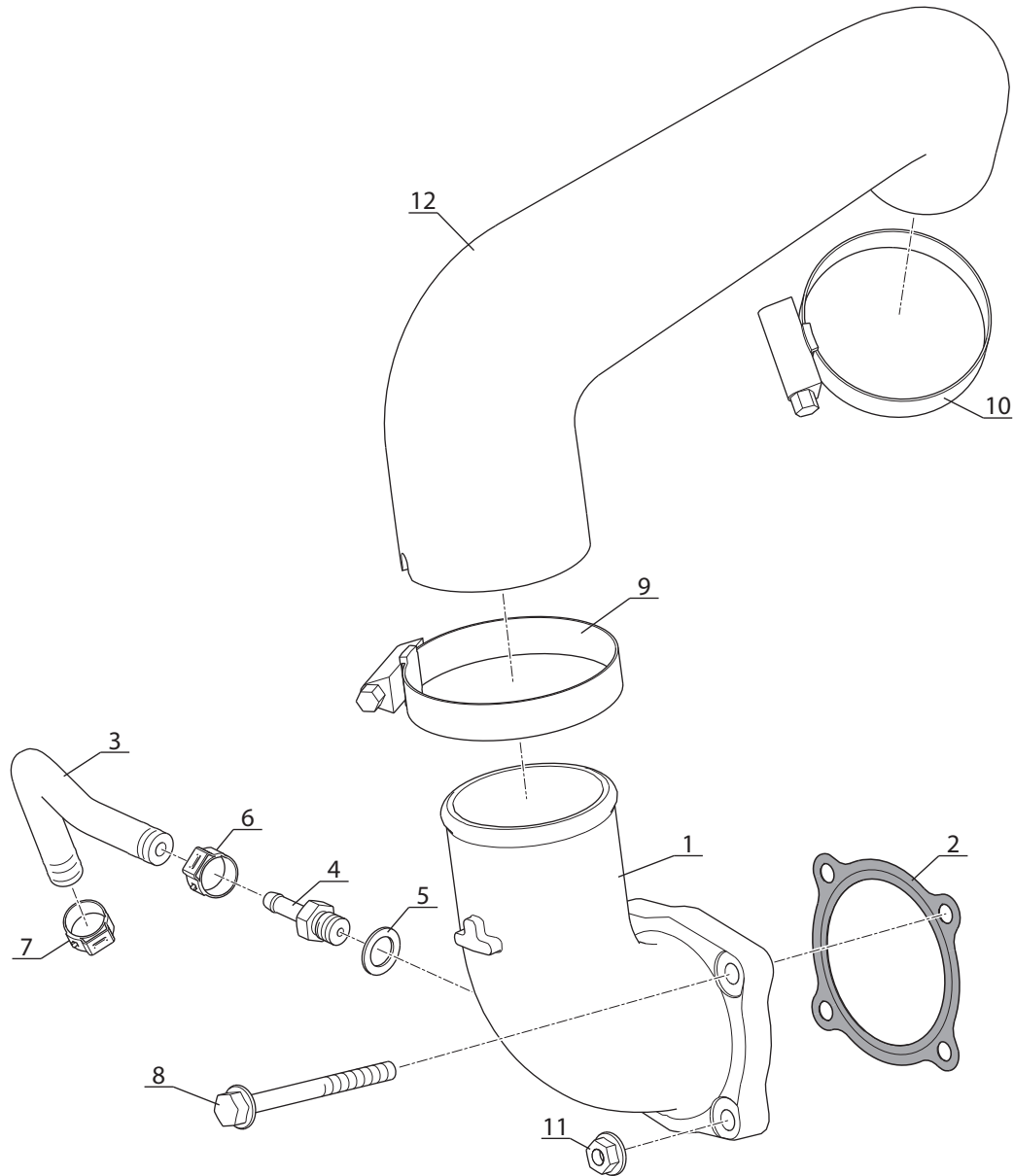

Catalogue : 298453MOD

1	MÉLANGEUR MISCHER MEZCLADOR MIXER MISCELATORE			Qte-Menge-Cant-Qty-Q.ta										AP 3258									
	Rep Hinw Fig Item Rif	Numéro Teil-Nr Numero Part-Nr Part-Nr	Désignation Bezeichnung Descripcion Description Descrizione	1	2	3	4	5	6	7	8	9	10	11	12	13	14	15	16	17	18	19	20
0	308397	Moteur complet Complete engine	- Kompletter motor - Motore completo	1																			
1	798643	Coude Bend	- Rohrbogen - Gomito	1																			
2	797326	Joint plat Gasket	- Dichtung - Guarnizióne	1																			
3	797724	Durit Hose	- Schlauch - Manicotto	1																			
4	797725	Raccord Adapteur Connection	- Verschraubung - Raccordo	1																			
5	797726	Joint Seal	- Dichtung - Guarnizióne	1																			
6	798647	Collier Clamp	- Spannschelle - Fascetta	1																			
7	798647	Collier Clamp	- Spannschelle - Fascetta	1																			
8	797727	Vis Screw	- Schraube - Vite	2																			
9	798645	Collier Clamp	- Spannschelle - Fascetta	1																			
10	798646	Collier Clamp	- Spannschelle - Fascetta	1																			
11	474068	Ecrou Nut	- Mutter - Dado	2																			
12	798644	Durit Hose	- Schlauch - Manicotto	1																			

M

AP 3259

POUR MOTEUR
FÜR MOTOR
PARA MOTOR
FOR ENGINE
PER MOTORE

□ Type: **JS 71001**
□ Ref: **298 453**

ALTERNATEUR
WECHSELSTROMGENERATOR
ALTERNADOR
ALTERNATOR
ALTERNATORE

M 26-2/4 ST3B
M 30-2/4 ST3B
M 40-2/4 ST3B
M 50-2/4 ST3B

M 26-2/4H ST3B
M 30-2/4H ST3B
M 40-2/4H ST3B
M 50-2/4H ST3B

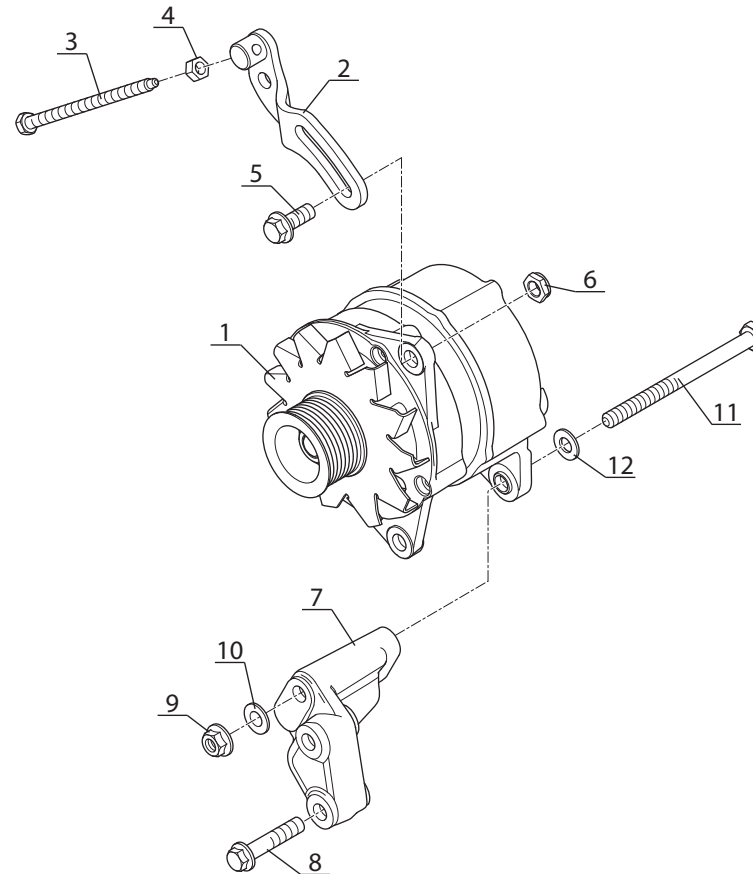

Catalogue : 298453MOD

1	ALTERNATEUR WECHSELSTROMGENERATOR ALTERNADOR ALTERNATOR ALTERNATORE			Qte-Menge-Cant-Qty-Q.ta										AP 3259									
				1- 298453MOD 11 - 2- 12 - 3- 13 - 4- 14 - 5- 15 - 6- 16 - 7- 17 - 8- 18 - 9- 19 - 10- 20 -																			
	Rep Hinw Fig Item Rif	Numéro Teil-Nr Numero Part-Nr Part-Nr	Désignation Bezeichnung Descripcion Description Descrizione	1	2	3	4	5	6	7	8	9	10	11	12	13	14	15	16	17	18	19	20
0	298453	Moteur complet Motor completo	- Kompletter motor - Motore completo	- Complete engine	1																		
1	797316	Alternateur Alternador	- Wechselstromgenerator - Alternatore	- Alternator	1																		
2	797675	Levier Palanca	- Hebel - Leva	- Lever	1																		
3	797676	Vis Tornillo	- Schraube - Vite	- Screw	1																		
4	552728	Ecrou Tuerca	- Mutter - Dado	- Nut	1																		
5	473956	Vis Tornillo	- Schraube - Vite	- Screw	2																		
6	797677	Ecrou Tuerca	- Mutter - Dado	- Nut	1																		
7	797678	Support Soporte	- Halter - Supporto	- Bracket	1																		
8	473988	Vis Tornillo	- Schraube - Vite	- Screw	2																		
9	473969	Ecrou Tuerca	- Mutter - Dado	- Nut	1																		
10	797679	Rondelle Arandela	- Unterlegscheibe - Rondella	- Washer	1																		
11	797680	Vis Tornillo	- Schraube - Vite	- Screw	1																		
12	797679	Rondelle Arandela	- Unterlegscheibe - Rondella	- Washer	1																		

M

AP 3260

POUR MOTEUR
FÜR MOTOR
PARA MOTOR
FOR ENGINE
PER MOTORE
 Type: **JS 71001**
 Ref: **298 453**

VOLANT-MOTEUR
SCHWUNGRAD
VOLANTE-MOTOR
FLYWHEEL
VOLANO MOTORE

M 26-2/4 ST3B	M 26-2/4H ST3B
M 30-2/4 ST3B	M 30-2/4H ST3B
M 40-2/4 ST3B	M 40-2/4H ST3B
M 50-2/4 ST3B	M 50-2/4H ST3B

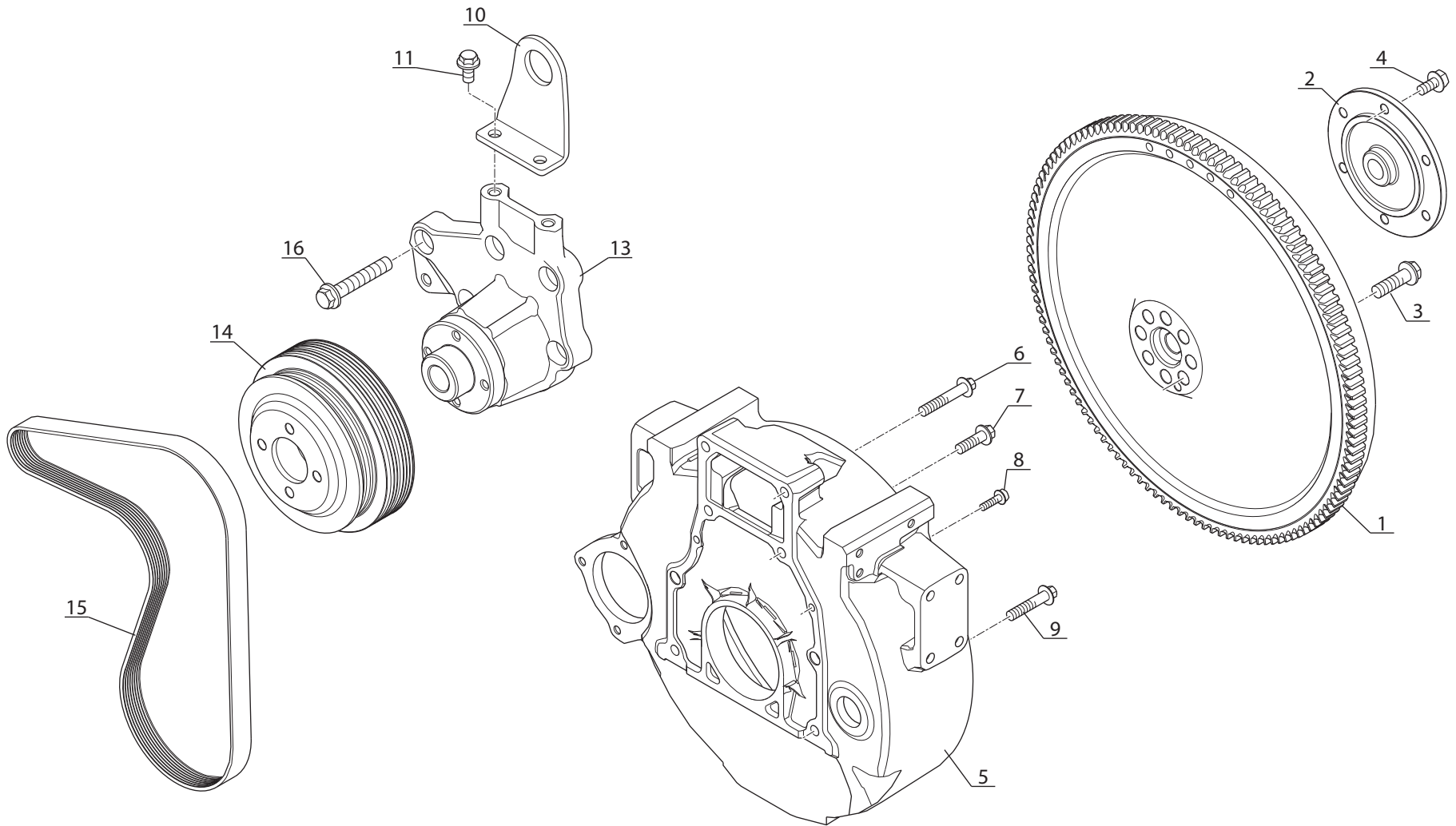

Catalogue : 298453MOD

1	VOLANT-MOTEUR SCHWUNGRAD VOLANTE-MOTOR FLYWHEEL VOLANO MOTORE			Qte-Menge-Cant-Qty-Q.ta										AP 3260									
	Rep Hinw Fig Item Rif	Numéro Teil-Nr Numero Part-Nr Part-Nr	Désignation Bezeichnung Descripcion Description Descrizione	1-	2-	3-	4-	5-	6-	7-	8-	9-	10-	11-	12-	13-	14-	15-	16-	17-	18-	19-	20-
				1	2	3	4	5	6	7	8	9	10	11	12	13	14	15	16	17	18	19	20
0	298453	Moteur complet Complete engine	- Kompletter motor - Motore completo	1																			
1	798534	Volant moteur Fly wheel	- Schwungrad - Volano motore	1																			
2	798410	Bride Flange	- Brida - Flangia	1																			
3	798411	Vis Screw	- Schraube - Vite	8																			
4	797606	Vis Screw	- Schraube - Vite	6																			
5	798532	Carter volant moteur Flywheel housing	- Schwungradgehäuse - Carcassa volano moto	1																			
6	798533	Vis Screw	- Schraube - Vite	2																			
7	797612	Vis Screw	- Schraube - Vite	2																			
8	797618	Vis Screw	- Schraube - Vite	2																			
9	797635	Vis Screw	- Schraube - Vite	4																			
10	797749	Patte Lug	- Auge - Piastra	1																			
11	798638	Vis Screw	- Schraube - Vite	2																			
13	798535	Support Bracket	- Halter - Supporto	1																			
14	798536	Poulie Pulley	- Riemen - Puleggia	1																			

M

+

Catalogue : 298453MOD

2	VOLANT-MOTEUR SCHWUNGRAD VOLANTE-MOTOR FLYWHEEL VOLANO MOTORE			Qte-Menge-Cant-Qty-Q.ta										AP 3260									
	Rep Hinw Fig Item Rif	Número Teil-Nr Numero Part-Nr Part-Nr	Désignation Bezeichnung Descripcion Description Descrizione	1-	2-	3-	4-	5-	6-	7-	8-	9-	10-	11-	12-	13-	14-	15-	16-	17-	18-	19-	20-
15	798537	Courroie d'alternateur alternador alternatore	- Wechselstromgeneratorriemen - Alternator belt - Alternatorriem	- Correa de - Cinghia di	1																		
16	473986	Vis (8 x 25) Screw	- Schraube - Vitei	- Tornillo	5																		

M

AP 3261

POUR MOTEUR
FÜR MOTOR
PARA MOTOR
FOR ENGINE
PER MOTORE

Type: **JS 71001**
 Ref: **298 453**

DEMARREUR
ANLASSER
MOTOR DE ARANQUE
STARTER MOTOR
MOTORINO AVVIAMENTO

M 26-2/4 ST3B
M 30-2/4 ST3B
M 40-2/4 ST3B
M 50-2/4 ST3B

M 26-2/4H ST3B
M 30-2/4H ST3B
M 40-2/4H ST3B
M 50-2/4H ST3B

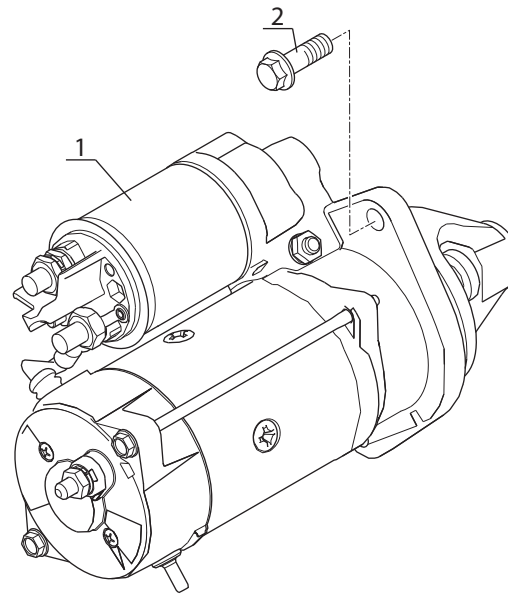

Catalogue : 298453MOD

1	DEMARREUR ANLASSER MOTOR DE ARANQUE STARTER MOTOR MOTORINO AVVIAMENTO			Qte-Menge-Cant-Qty-Q.ta-										AP 3261									
	Rep Hinw Fig Item Rif	Numéro Teil-Nr Numero Part-Nr Part-Nr	Désignation Bezeichnung Descripcion Description Descrizione	1	2	3	4	5	6	7	8	9	10	11	12	13	14	15	16	17	18	19	20
0	298453	Moteur complet Complete engine	- Kompletter motor - Motore completo - Motor completo	1																			
1	798412	Démarrreur Starter motor	- Anlasser - Motorino avviamento - Arrancador	1																			
2	473958	Vis (10 x 30) Screw	- Schraube - Vite - Tornillo	3																			

M

AP 3262

POUR MOTEUR
FÜR MOTOR
PARA MOTOR
FOR ENGINE
PER MOTORE

□ Type: JS 71001
□ Ref: 298 453

TURBO-COMPRESSEUR (Détails)
TURBOKOMPRESSOR (Einzelteile)
TURBOCOMPRESSOR (Details)
TURBOCHARGER (Details)
TURBOCOMPRESSORE (Dettaglio)

M 26-2/4 ST3B
M 30-2/4 ST3B
M 40-2/4 ST3B
M 50-2/4 ST3B

M 26-2/4H ST3B
M 30-2/4H ST3B
M 40-2/4H ST3B
M 50-2/4H ST3B

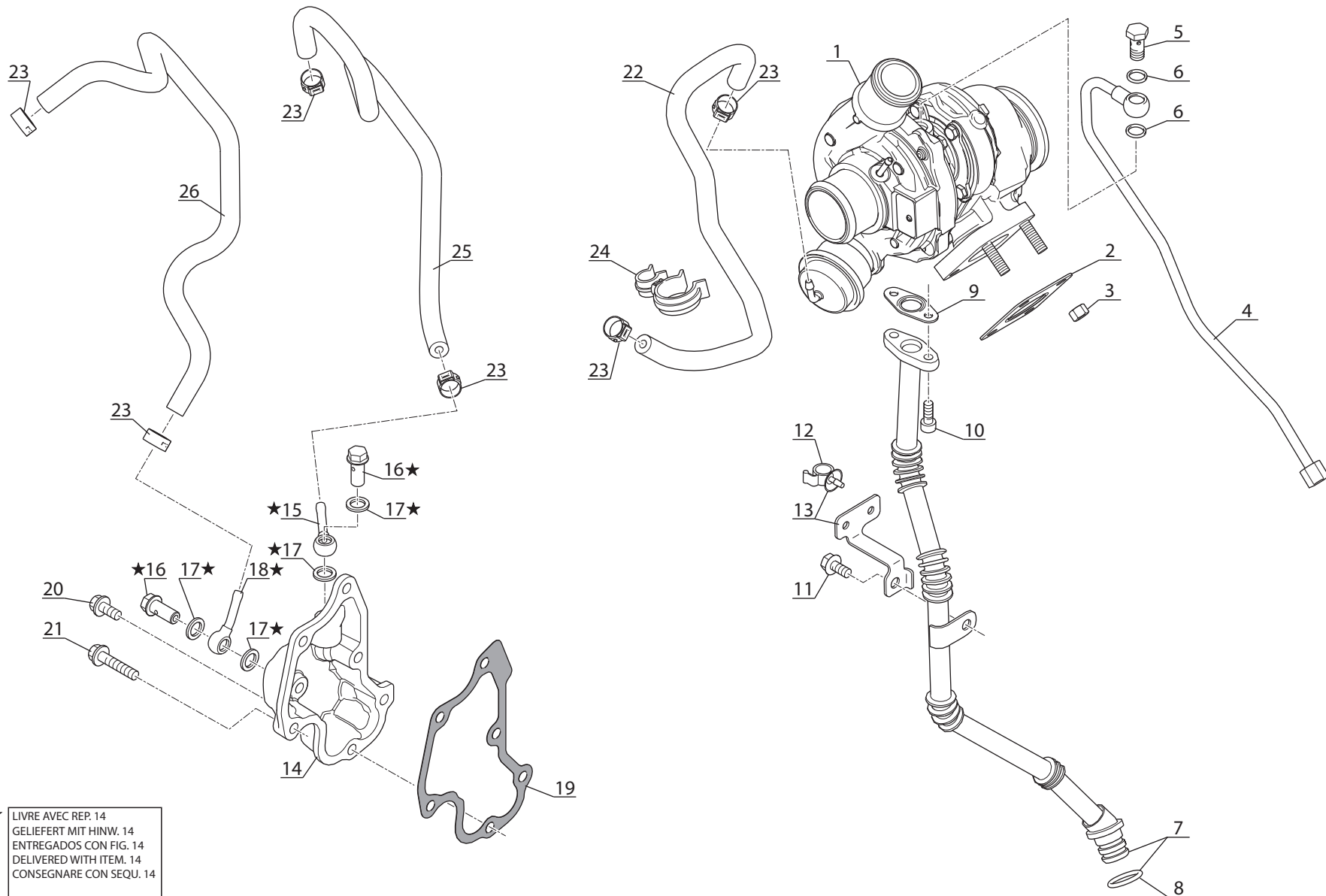

★ LIVRE AVEC REP. 14
GELIEFERT MIT HINW. 14
ENTREGADOS CON FIG. 14
DELIVERED WITH ITEM. 14
CONSEGNARE CON SEQU. 14

Catalogue : 298453MOD

1	TURBO-COMPRESSEUR (Détails) TURBOKOMPRESSOR (Einzelteile) TURBOCOMPRESOR (Detalles) TURBOCHARGER (Details) TURBOCOMPRESSORE (Dettaglio)			Qte-Menge-Cant-Qty-Q.ta																AP 3262				M			
	Rep Hinw Fig Item Rif	Numéro Teil-Nr Numero Part-Nr Part-Nr	Désignation Bezeichnung Descripcion Description Descrizione																								
				1	2	3	4	5	6	7	8	9	10	11	12	13	14	15	16	17	18	19	20				
1	797372	Turbo-compresseur Turbocharger	- Turbolader - Turbocompressore	- Turbo compresor	1																						
2	797329	Joint plat Gasket	- Dichtung - Guarnizióne	- Junta plana	1																						
3	797694	Ecrou Nut	- Mutter - Dado	- Tuerca	2																						
4	797695	Tube Tube	- Rohr - Tubo	- Tubo	1																						
5	797629	Vis creuse Hollow screw	- Hohlschraube - Vite cava	- Tornillo hueco	1																						
6	797331	Joint Seal	- Dichtung - Guarnizióne	- Junta	2																						
7	798688	Tuyau Hose	- Schlauch - Tubo	- Tubo	1																						
8	797344	Joint torique "O" ring	- "O" ring - Anello OR	- Junta tórica	2																						
9	797330	Joint plat Gasket	- Dichtung - Guarnizióne	- Junta plana	1																						
10	797673	Vis Screw	- Schraube - Vite	- Tornillo	2																						
11	797606	Vis Screw	- Schraube - Vite	- Tornillo	1																						
12	798447	Collier Clamp	- Spannschelle - Fascetta	- Abrazadera	2																						
13	798692	Support Bracket	- Halter - Supporto	- Soporte	1																						
14	798689	Carter Housing	- Gehäuse - Carter	- Cártter	1																						

+

Catalogue : 298453MOD

2	TURBO-COMPRESSEUR (Détails) TURBOKOMPRESSOR (Einzelteile) TURBOCOMPRESOR (Detalles) TURBOCHARGER (Details) TURBOCOMPRESSORE (Dettaglio)				Qte-Menge-Cant-Qty-Q.ta										AP 3262										M
	1- 298453MOD	11 -	2-	12 -	3-	13 -	4-	14 -	5-	15 -	6-	16 -	7-	17 -	8-	18 -	9-	19 -	10-	20 -					
Rep	Numéro	Désignation			1	2	3	4	5	6	7	8	9	10	11	12	13	14	15	16	17	18	19	20	
Hinw	Teil-Nr	Bezeichnung																							
Fig	Numero	Descricion																							
Item	Part-Nr	Description																							
Rif	Part-Nr	Descrizione																							
15	798696	Raccord banjo Banjo connection	- Verschraubung - Raccordo	- Racor banjo	1																				
16	798441	Vis creuse Hollow screw	- Hohlschraube - Vite cava	- Tornillo hueco	2																				
17	798442	Joint Seal	- Dichtung - Guarnizióne	- Junta	4																				
18	798695	Raccord banjo Banjo connection	- Verschraubung - Raccordo	- Racor banjo	1																				
19	798445	Joint plat Gasket	- Dichtung - Guarnizióne	- Junta plana	1																				
20	474018	Vis (6 x 14) Screw	- Schraube - Vite	- Tornillo	3																				
21	563275	Vis Screw	- Schraube - Vite	- Tornillo	3																				
22	798694	Tube Tube	- Rohr - Tubo	- Tubo	1																				
23	798647	Collier Clamp	- Spannschelle - Fascetta	- Abrazadera	6																				
24	797697	Collier Clamp	- Spannschelle - Fascetta	- Abrazadera	1																				
25	798690	Tube Tube	- Rohr - Tubo	- Tubo	1																				
26	798691	Tube Tube	- Rohr - Tubo	- Tubo	1																				

AP 3263

POUR MOTEUR
FÜR MOTOR
PARA MOTOR
FOR ENGINE
PER MOTORE

□ Type: JS 71001
□ Ref: 298 453

TURBO-COMPRESSEUR (Détails)
TURBOKOMPRESSOR (Einzelteile)
TURBOCOMPRESSOR (Detalles)
TURBOCHARGER (Details)
TURBOCOMPRESSORE (Dettaglio)

M 26-2/4 ST3B
M 30-2/4 ST3B
M 40-2/4 ST3B
M 50-2/4 ST3B

M 26-2/4H ST3B
M 30-2/4H ST3B
M 40-2/4H ST3B
M 50-2/4H ST3B

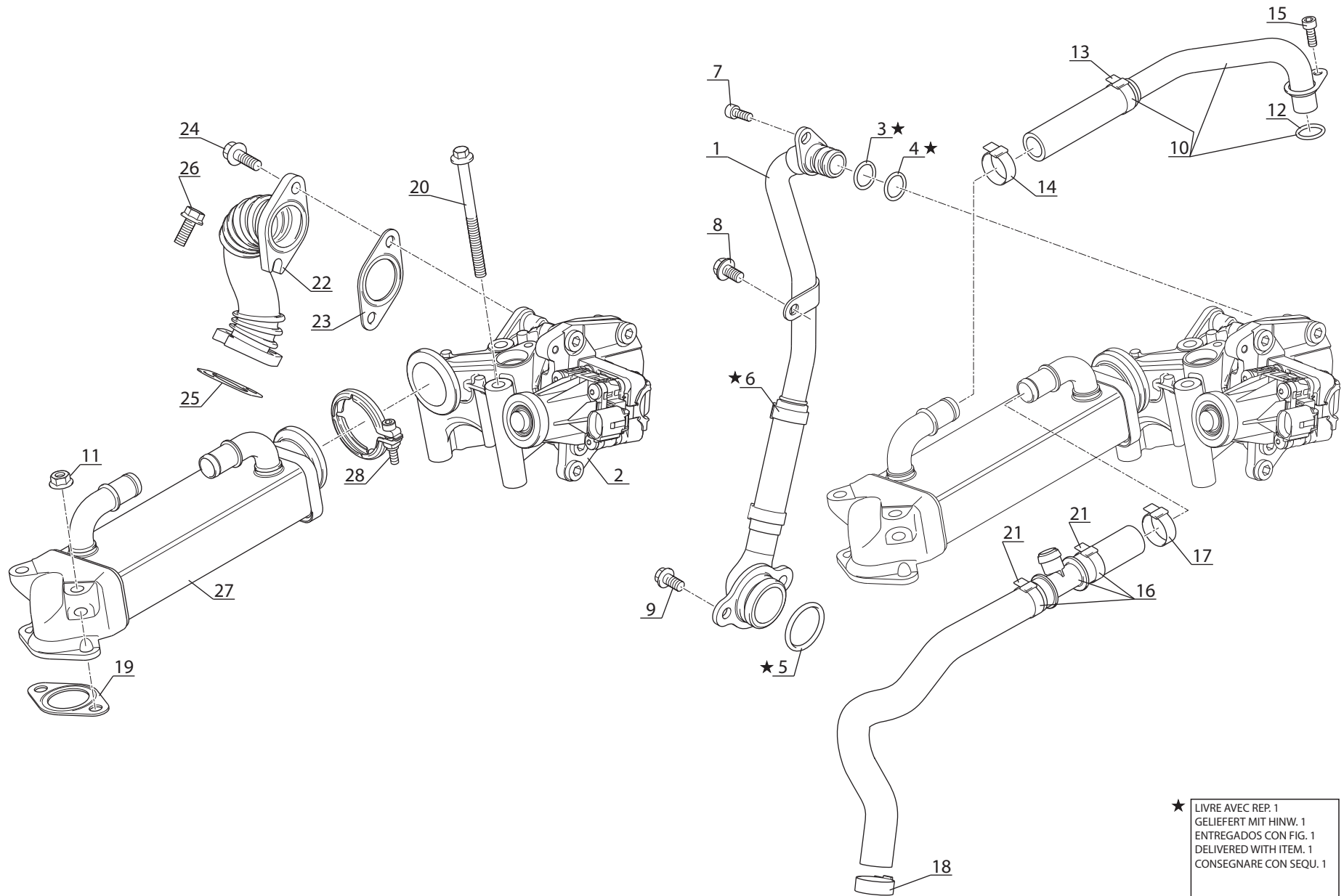

★ LIVRE AVEC REP. 1
GELIEFERT MIT HINW. 1
ENTREGADOS CON FIG. 1
DELIVERED WITH ITEM. 1
CONSEGNARE CON SEQU. 1

Catalogue : 298453MOD

1	TURBO-COMPRESSEUR (Détails) TURBOKOMPRESSOR (Einzelteile) TURBOCOMPRESOR (Detalles) TURBOCHARGER (Details) TURBOCOMPRESSORE (Dettaglio)			Qte-Menge-Cant-Qty-Q.ta										AP 3263									
	Rep Hinw Fig Item Rif	Numéro Teil-Nr Numero Part-Nr Part-Nr	Désignation Bezeichnung Descripcion Description Descrizione	1-	2-	3-	4-	5-	6-	7-	8-	9-	10-	11 -	12 -	13 -	14 -	15 -	16 -	17 -	18 -	19 -	20 -
				1	2	3	4	5	6	7	8	9	10	11	12	13	14	15	16	17	18	19	20
1	797713	Tube Tube	- Rohr - Tubo	1																			
2	797710	Valve Valve	- Ventil - Valvola	1																			
3	797344	Joint torique "0" ring	- "0" ring - Anello OR	1																			
4	797344	Joint torique "0" ring	- "0" ring - Anello OR	1																			
5	797345	Joint torique "0" ring	- "0" ring - Anello OR	1																			
6	797714	Clip Clip	- Klammer - Fermaglio	2																			
7	797673	Vis Screw	- Schraube - Vite	1																			
8	552727	Vis Screw	- Schraube - Vite	1																			
9	797715	Vis Screw	- Schraube - Vite	2																			
10	797716	Tube Tube	- Rohr - Tubo	1																			
11	473939	Ecrou Nut	- Mutter - Dado	2																			
12	797344	Joint torique "0" ring	- "0" ring - Anello OR	1																			
13	797714	Clip Clip	- Klammer - Fermaglio	1																			
14	797714	Clip Clip	- Klammer - Fermaglio	1																			

M

+

Catalogue : 298453MOD

2	TURBO-COMPRESSEUR (Détails) TURBOKOMPRESSOR (Einzelteile) TURBOCOMPRESOR (Detalles) TURBOCHARGER (Details) TURBOCOMPRESSORE (Dettaglio)			Qte-Menge-Cant-Qty-Q.ta-Boel-Suure										AP 3263									
	Rep Hinw Fig Item Rif	Número Teil-Nr Numero Part-Nr Part-Nr	Désignation Bezeichnung Descripcion Description Descrizione	1-	2-	3-	4-	5-	6-	7-	8-	9-	10-	11-	12-	13-	14-	15-	16-	17-	18-	19-	20-
15	797673	Vis Screw	- Schraube - Vite	- Tornillo	1																		
16	797717	Tube Tube	- Rohr - Tubo	- Tubo	1																		
17	797714	Clip Clip	- Klammer - Fermaglio	- Clip	1																		
18	797714	Clip Clip	- Klammer - Fermaglio	- Clip	1																		
19	797327	Joint plat Gasket	- Dichtung - Guarnizióne	- Junta plana	1																		
20	775836	Vis Screw	- Schraube - Vite	- Tornillo	3																		
21	797714	Clip Clip	- Klammer - Fermaglio	- Clip	2																		
22	797712	Tuyau Hose	- Schlauch - Tubo	- Tubo	1																		
23	797327	Joint plat Gasket	- Dichtung - Guarnizióne	- Junta plana	1																		
24	797636	Vis Screw	- Schraube - Vite	- Tornillo	2																		
25	797327	Joint plat Gasket	- Dichtung - Guarnizióne	- Junta plana	1																		
26	797633	Vis Screw	- Schraube - Vite	- Tornillo	2																		
27	797709	Echangeur thermique calor	- Wärmetauscher - Heat exchanger	- Intercambiador de - Scambiatore termico	1																		
28	797711	Collier Clamp Puristin	- Spannschelle - Fascetta	- Abrazadera - Klem	1																		

M

AP 3264

POUR MOTEUR
FÜR MOTOR
PARA MOTOR
FOR ENGINE
PER MOTORE

Type: **JS 71001**
 Ref: **298 453**

MODULE COMMANDE MOTEUR
MOTORSTEUERGERAT
MOTOR DE LA UNIDAD DE CONTROL
ENGINE CONTROL MODULE
UNITA DI CONTROLLO MOTORE

M 26-2/4 ST3B
M 30-2/4 ST3B
M 40-2/4 ST3B
M 50-2/4 ST3B

M 26-2/4H ST3B
M 30-2/4H ST3B
M 40-2/4H ST3B
M 50-2/4H ST3B

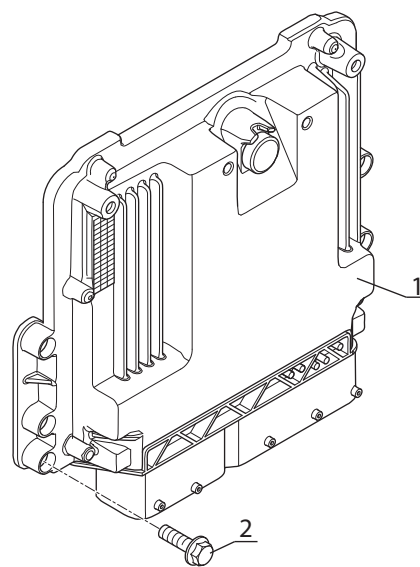

Catalogue : 298453MOD

1	MODULE COMMANDE MOTEUR MOTORSTEUERGERAT MOTOR DE LA UNIDAD DE CONTROL ENGINE CONTROL MODULE UNITA DI CONTROLLO MOTORE			Qte-Menge-Cant-Qty-Q.ta										AP 3264									
	Rep Hinw Fig Item Rif	Numéro Teil-Nr Numero Part-Nr Part-Nr	Désignation Bezeichnung Descripcion Description Descrizione	1	2	3	4	5	6	7	8	9	10	11	12	13	14	15	16	17	18	19	20
0	298453	Moteur complet Complete engine	- Kompletter motor - Motore completo - Motor completo	1																			
1	797659	Module commande moteur de control motore	- Motorsteuergerat - Engine control mod. - Unita di controllo	1																			
2	552894	Vis Screw	- Schraube - Vite - Tornillo	2																			

M

AP 3265

POUR MOTEUR
FÜR MOTOR
PARA MOTOR
FOR ENGINE
PER MOTORE

□ Type: **JS 71001**
□ Ref: **298 453**

CIRCUIT COMBUSTIBLE
BRENNSTOFFKREIS
CIRCUITO COMBUSTIBLE
FUEL CIRCUIT
SISTEMA NAFTA

M 26-2/4 ST3B	M 26-2/4H ST3B
M 30-2/4 ST3B	M 30-2/4H ST3B
M 40-2/4 ST3B	M 40-2/4H ST3B
M 50-2/4 ST3B	M 50-2/4H ST3B

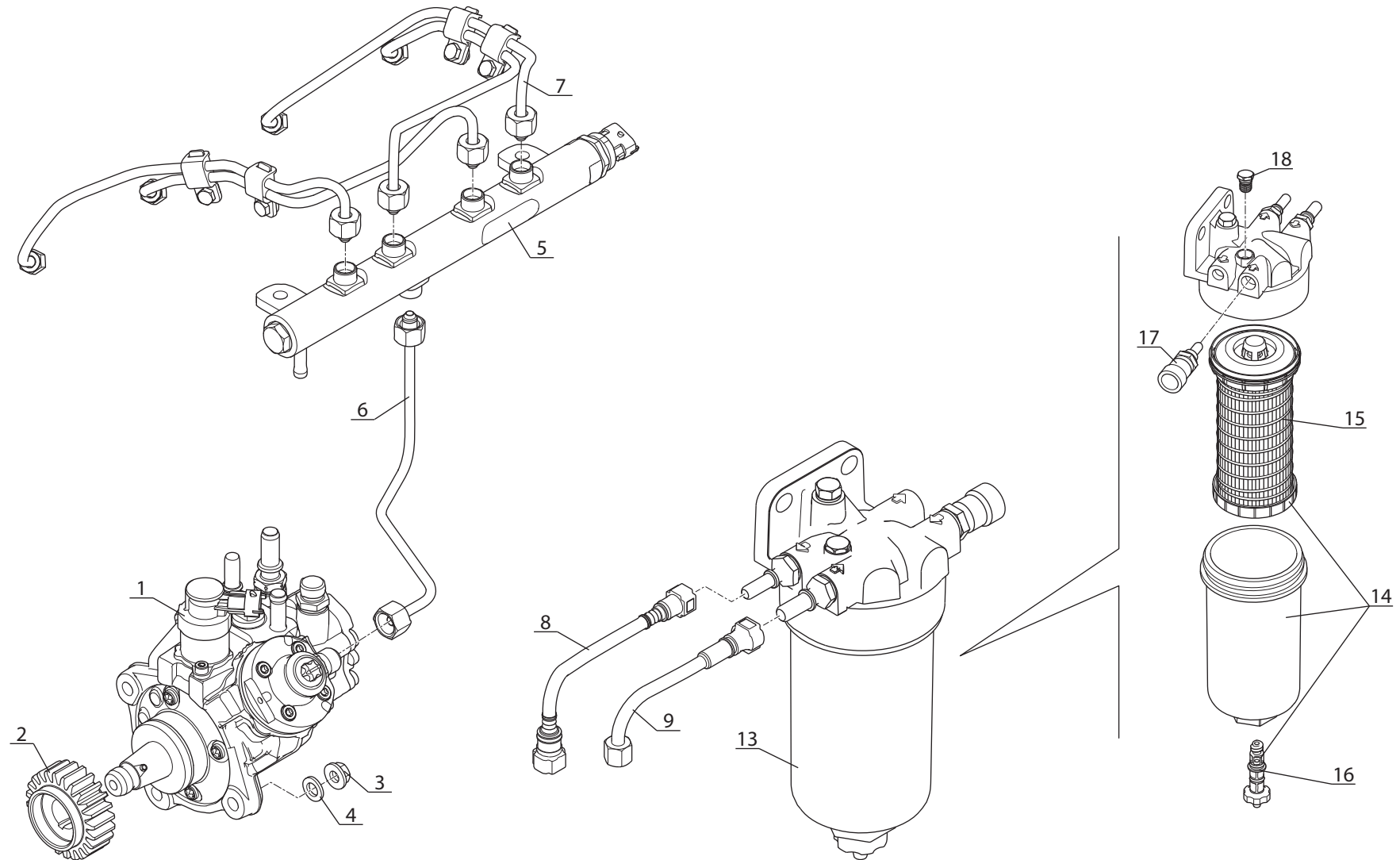

Catalogue : 298453MOD

1				CIRCUIT COMBUSTIBLE BRENNSTOFFKREIS CIRCUITO COMBUSTIBLE FUEL CIRCUIT SISTEMA NAFTA		Qte-Menge-Cant-Qty-Q.ta										AP 3265									
Rep Hinw Fig Item Rif	Numéro Teil-Nr Numero Part-Nr Part-Nr	Désignation Bezeichnung Descripcion Description Descrizione			1-	2-	3-	4-	5-	6-	7-	8-	9-	10-	11-	12-	13-	14-	15-	16-	17-	18-	19-	20-	
0	298453	Moteur complet Complete engine	- Kompletter motor - Motore completo	- Motor completo	1																				
1	797374	Pompe d'injection Injection pump	- Einspritzpumpe - Pompa iniezione	- Bomba de inyección	1																				
2	797622	Pignon Gear	- Zahnrad - Ingranaggio	- Piñón	1																				
3	473939	Ecrou Nut	- Mutter - Dado	- Tuerca	3																				
4	109358	Rondelle Washer	- Unterlegscheibe - Rondella	- Arandela	3																				
5	797373	Rampe d'injection Injection manifold	- Injektionsverteiler - Collettore di iniez	- Colector de inyecc.	1																				
6	797376	Tuyau d'injection Injection pipe	- Einspritz leitung - Tubo iniezione	- Tubo de inyección	1																				
7	797375	Tuyau d'injection Injection pipe	- Einspritz leitung - Tubo iniezione	- Tubo de inyección	1																				
8	798460	Durit Hose	- Schlauch - Manicotto	- Tubo flexible	1																				
9	798461	Tube Tube	- Rohr - Tubo	- Tubo	1																				
13	797740	Filtre à combust comp. comp.	- Komplet. brennstoffi. - Complete fuel filter	-Filtro de combust - Filtro gasolio comp	1																				
14	797741	Filtre Filter	- Filter - Filtro	- Filtro	1																				
15	296854	Filtre à combustible Fuel filter	- Brennstofffilter - Filtro gasolio	- Filtro de combust.	1																				
16	797743	Bouchon de vidange Drain plug	- Ablassschraube - Tappo di scarico	- Tapón de vaciado	1																				

M

Catalogue : 298453MOD

Rep Hinw Fig Item Rif	Numéro Teil-Nr Numero Part-Nr Part-Nr	Désignation Bezeichnung Descripcion Description Descrizione	Beschrijving Kuvaus	Qte-Menge-Cant-Qty-Q.ta																				
				1	2	3	4	5	6	7	8	9	10	11	12	13	14	15	16	17	18	19	20	
2		CIRCUIT COMBUSTIBLE BRENNSTOFFKREIS CIRCUITO COMBUSTIBLE FUEL CIRCUIT SISTEMA NAFTA			AP 3265																			
				1- 298453MOD	11 -																			
				2-	12 -																			
				3-	13 -																			
				4-	14 -																			
				5-	15 -																			
				6-	16 -																			
				7-	17 -																			
				8-	18 -																			
				9-	19 -																			
				10-	20 -																			
17	797357	Sonde de température Temperature sensor	- Temperatur transmit. - Sonda de temperat. - Sonda di temperatura	1																				
18	797744	Bouchon Plug	- Stopfen - Tappo	1																				

M

AP 3266

POUR MOTEUR
FÜR MOTOR
PARA MOTOR
FOR ENGINE
PER MOTORE

□ Type: **JS 71001**
□ Ref: **298 453**

CIRCUIT COMBUSTIBLE
BRENNSTOFFKREIS
CIRCUITO COMBUSTIBLE
FUEL CIRCUIT
SISTEMA NAFTA

M 26-2/4 ST3B
M 30-2/4 ST3B
M 40-2/4 ST3B
M 50-2/4 ST3B

M 26-2/4H ST3B
M 30-2/4H ST3B
M 40-2/4H ST3B
M 50-2/4H ST3B

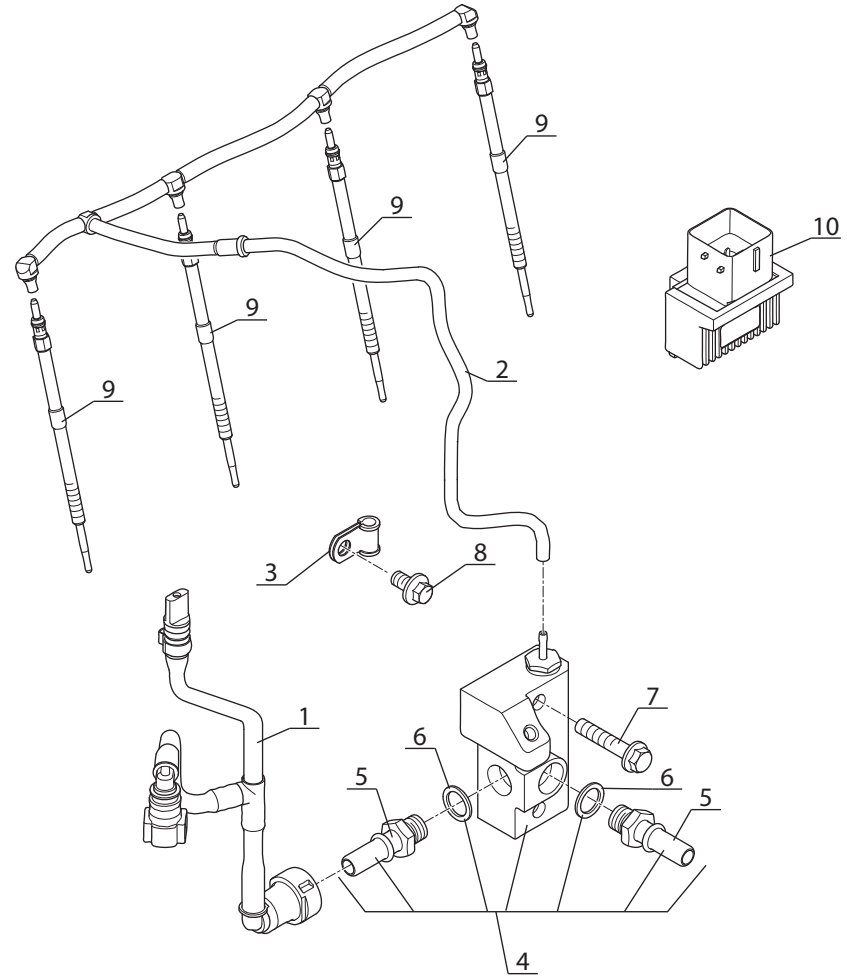

Catalogue : 298453MOD

1	CIRCUIT COMBUSTIBLE BRENNSTOFFKREIS CIRCUITO COMBUSTIBILE FUEL CIRCUIT SISTEMA NAFTA			Qte-Menge-Cant-Qty-Q.ta																AP 3266	M		
	Rep Hinw Fig Item Rif	Numéro Teil-Nr Numero Part-Nr Part-Nr	Désignation Bezeichnung Descripcion Description Descrizione	1-	2-	3-	4-	5-	6-	7-	8-	9-	10-	11-	12-	13-	14-	15-	16-	17-	18-	19-	20-
				1	2	3	4	5	6	7	8	9	10	11	12	13	14	15	16	17	18	19	20
0	298453	Moteur complet Complete engine	- Kompletter motor - Motore completo - Motor completo	1																			
1	797734	Durit Hose	- Schlauch - Manicotto	- Tubo flexible	1																		
2	797735	Durit Hose	- Schlauch - Manicotto	- Tubo flexible	1																		
3	797736	Collier Clamp	- Spannschelle - Fascetta	- Abrazadera	1																		
4	797737	Jonction Junction	- Einsatz - Attacco	- Junta	1																		
5	797738	Raccord Connection	- Verschraubung - Raccordo	- Racor	2																		
6	797739	Joint Seal	- Dichtung - Guarnizióne	- Junta	2																		
7	474028	Vis (8 x 50) Screw	- Schraube - Vite	- Tornillo	2																		
8	552727	Vis Screw	- Schraube - Vite	- Tornillo	1																		
9	797353	Bougie de préchauffage tamiento	- Glühkerze - Heating plug	- Bujía de precalen- - Termostarter	4																		
10	297828	Boîtier de contrôle préchauffage Box	- Kasten - Scàtola	- Cártar	1																		

AP 3267

POUR MOTEUR
FÜR MOTOR
PARA MOTOR
FOR ENGINE
PER MOTORE

□ Type: **JS 71001**
□ Ref: **298 453**

CIRCUIT COMBUSTIBLE
BRENNSTOFFKREIS
CIRCUITO COMBUSTIBLE
FUEL CIRCUIT
SISTEMA NAFTA

M 26-2/4 ST3B
M 30-2/4 ST3B
M 40-2/4 ST3B
M 50-2/4 ST3B

M 26-2/4H ST3B
M 30-2/4H ST3B
M 40-2/4H ST3B
M 50-2/4H ST3B

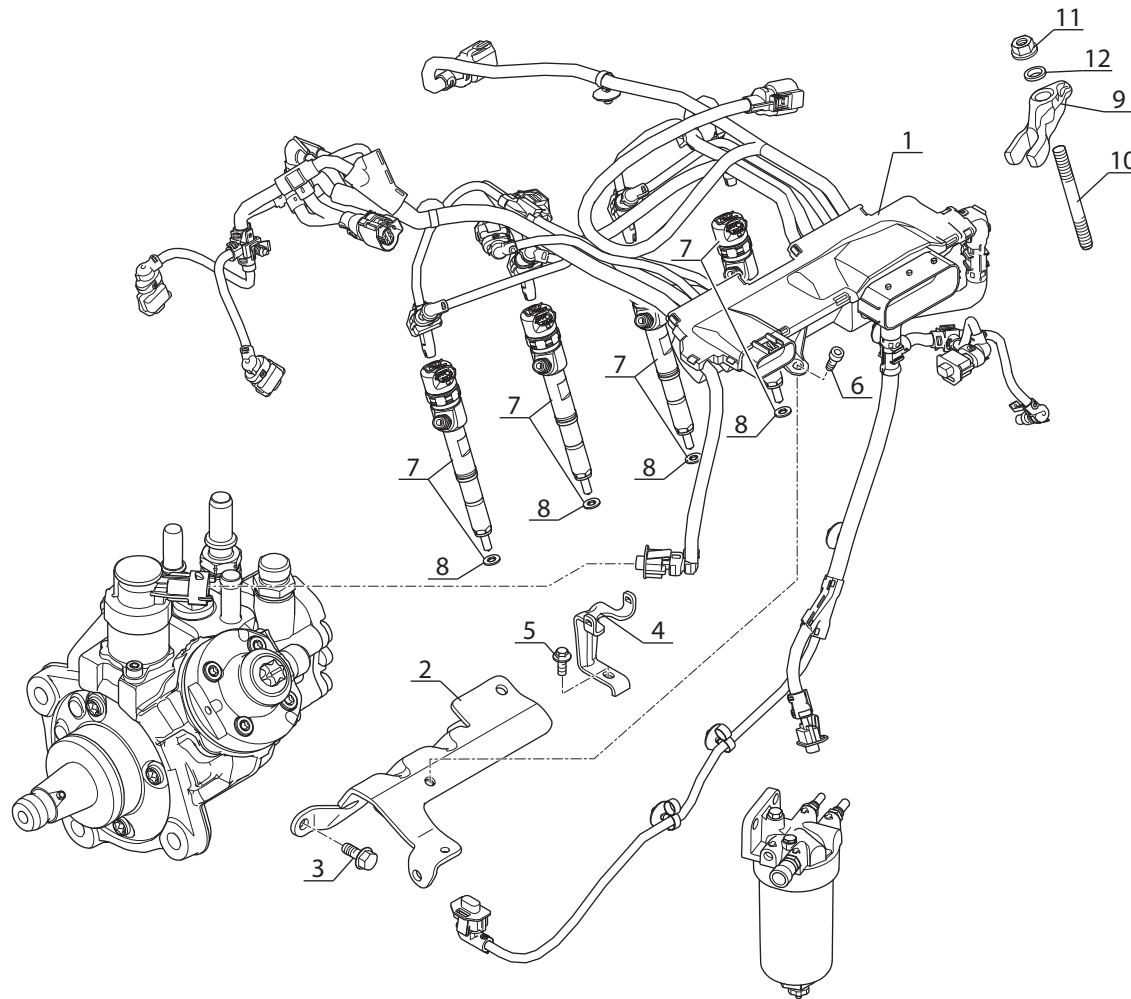

Catalogue : 298453MOD

1	CIRCUIT COMBUSTIBLE BRENNSTOFFKREIS CIRCUITO COMBUSTIBLE FUEL CIRCUIT SISTEMA NAFTA			Qte-Menge-Cant-Qty-Q.ta																AP 3267				
	Rep Hinw Fig Item Rif	Numéro Teil-Nr Numero Part-Nr Part-Nr	Désignation Bezeichnung Descripcion Description Descrizione	1- 298453MOD	11 -	2 -	12 -	3 -	13 -	4 -	14 -	5 -	15 -	6 -	16 -	7 -	17 -	8 -	18 -	9 -	19 -	10 -	20 -	
0	298453	Moteur complet Complete engine	- Kompletter motor - Motore completo - Motor completo	1																				
1	797354	Faisceau moteur Engine wiring harness	- Motor kabelbaum - Fascio motore	1																				
2	797750	Support Bracket	- Halter - Supporto	1																				
3	797633	Vis Screw	- Schraube - Vite	3																				
4	797751	Support Bracket	- Halter - Supporto	2																				
5	474018	Vis (6 x 14) Screw	- Schraube - Vite	2																				
6	797752	Vis Screw	- Schraube - Vite	1																				
7	797317	Injecteur Injector	- Einspritzdüse - Atomizzatore	4																				
8	797356	Rondelle Washer	- Unterlegscheibe - Rondella	4																				
9	797619	Pince Pliers	- Zange - Pinze	4																				
10	797620	Goujon Stud-bolt	- Stiftschraube - Prigioniero	4																				
11	473939	Ecrou Nut	- Mutter - Dado	4																				
12	797621	Rondelle Washer	- Unterlegscheibe - Rondella	4																				

AP 3268

POUR MOTEUR
FÜR MOTOR
PARA MOTOR
FOR ENGINE
PER MOTORE

Type: **JS 71001**
 Ref: **298 453**

FILTRE A HUILE
ÖLFILTER
FILTRO DE ACEITE
OIL FILTER
FILTRO OLIO

M 26-2/4 ST3B
M 30-2/4 ST3B
M 40-2/4 ST3B
M 50-2/4 ST3B

M 26-2/4H ST3B
M 30-2/4H ST3B
M 40-2/4H ST3B
M 50-2/4H ST3B

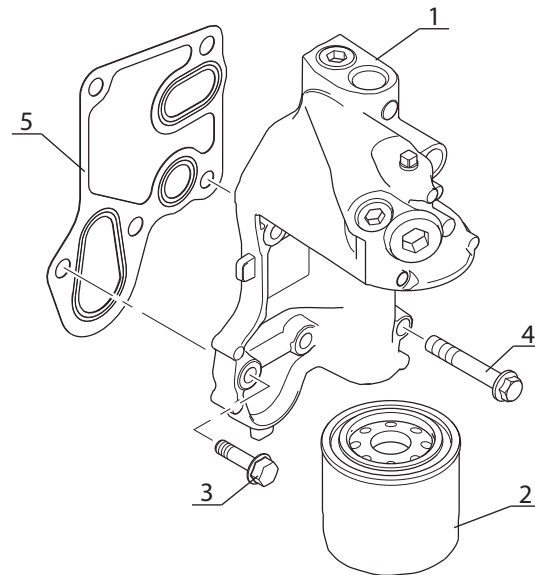

Catalogue : 298453MOD

1		FILTRE A HUILE ÖLFILTER FILTRO DE ACEITE OIL FILTER FILTRO OLIO			Qte-Menge-Cant-Qty-Q.ta										AP 3268									
Rep Hinw Fig Item Rif	Numéro Teil-Nr Numero Part-Nr Part-Nr	Désignation Bezeichnung Descripcion Description Descrizione			1- 298453MOD 11 - 2- 12 - 3- 13 - 4- 14 - 5- 15 - 6- 16 - 7- 17 - 8- 18 - 9- 19 - 10- 20 -																			
					1	2	3	4	5	6	7	8	9	10	11	12	13	14	15	16	17	18	19	20
0	298453	Moteur complet Complete engine	- Kompletter motor - Motore completo	- Motor completo	1																			
1	798423	Support Bracket	- Halter - Supporto	- Soporte	1																			
2	924194	Filtre à huile Oil filter	- Ölfilter - Filtro olio	- Filtro aceite	1																			
3	797618	Vis Screw	- Schraube - Vite	- Tornillo	3																			
4	474039	Vis Screw	- Schraube - Vite	- Tornillo	2																			
5	798425	Joint plat Gasket	- Dichtung - Guarnizióne	- Junta plana	1																			

M

AP 3269

POUR MOTEUR
FÜR MOTOR
PARA MOTOR
FOR ENGINE
PER MOTORE

□ □ Type: **JS 71001**
□ □ Ref: **298 453**

BRIDE D'ADAPTATION
ANPASSUNG BRIDA
FLANGIA ADAPTACION
ADAPTACION FLANGE
FLANGIA ADATTAMENTO

M 26-2/4 ST3B
M 30-2/4 ST3B
M 40-2/4 ST3B
M 50-2/4 ST3B

M 26-2/4H ST3B
M 30-2/4H ST3B
M 40-2/4H ST3B
M 50-2/4H ST3B

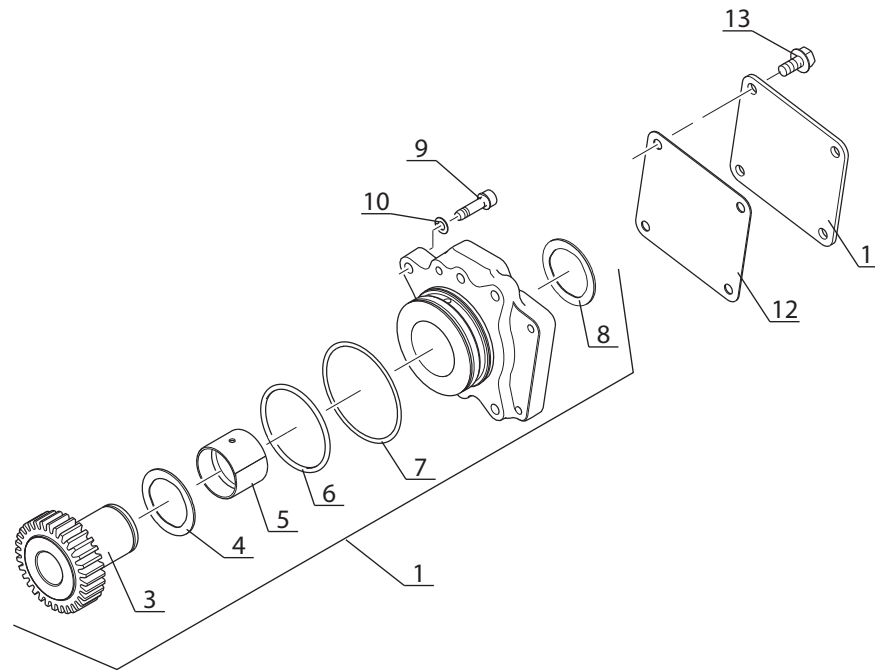

Catalogue : 298453MOD

1	BRIDE D'ADAPTATION ANPASSUNG BRIDA FLANGIA ADAPTACION ADAPTACION FLANGE FLANGIA ADATTAMENTO			Qte-Menge-Cant-Qty-Q.ta										AP 3269									
	Rep Hinw Fig Item Rif	Numéro Teil-Nr Numero Part-Nr Part-Nr	Désignation Bezeichnung Descripcion Description Descrizione	1-	2-	3-	4-	5-	6-	7-	8-	9-	10-	11-	12-	13-	14-	15-	16-	17-	18-	19-	20-
				1	2	3	4	5	6	7	8	9	10	11	12	13	14	15	16	17	18	19	20
0	298453	Moteur complet Complete engine	- Kompletter motor - Motore completo - Motor completo	1																			
1	798427	Pignon entraineur Drive gear	- Zahnradmitnehmer - Ingranaggio de dispositivo di trasmissione - Piñón arrastrador	1																			
3	798428	Pignon Gear	- Zahnrad - Ingranaggio - Piñón	1																			
4	798429	Rondelle Washer	- Unterlegscheibe - Rondella - Arandela	1																			
5	798430	Bague Bushing	- Büchse - Anello - Anillo	1																			
6	798431	Joint torique "O" ring	- "O" ring - Anello OR - Junta tórica	1																			
7	797346	Joint torique "O" ring	- "O" ring - Anello OR - Junta tórica	1																			
8	798429	Rondelle Washer	- Unterlegscheibe - Rondella - Arandela	1																			
9	797746	Vis Screw	- Schraube - Vite - Tornillo	3																			
10	798432	Rondelle Washer	- Unterlegscheibe - Rondella - Arandela	3																			
11	798433	Plaque de fermeture Fastening plate	- Schlussplatte - Piastra di chiusura - Placa de cierre	1																			
12	798434	Joint plat Gasket	- Dichtung - Guarnizióne - Junta plana	1																			
13	797606	Vis Screw	- Schraube - Vite - Tornillo	4																			

M

BOITE DE VITESSES - GETRIEBEKASTEN

CAJA DE VELOCIDADES - GEAR BOX

CAMBIO

TYPE - TYPEN

TIPO - TYPE

TIPO

16564

REFERENCE - NUMMER

NUMERO - NUMBER

RIFERIMENTO

264 389

BP 8065

POUR BOITE DE VITESSES
FÜR GETRIEBEKASTEN
PARA CAJA DE VELOCIDADES
FOR GEAR BOX
PER CAMBIO

Type: **16564**
Réf: **264 389**

BOITE DE VITESSES ET CONVERTISSEUR
GETRIEBEKASTEN UND UMFORMER
CAJA DE VELOCIDADES Y CONVERTIDOR
GEAR BOX AND CONVERTER
CAMBIO E CONVERTITORE

M 26-2 ST3B
M 30-2 ST3B
M 40-2 ST3B
M 50-2 ST3B

M 26-2H ST3B
M 30-2H ST3B
M 40-2H ST3B
M 50-2H ST3B

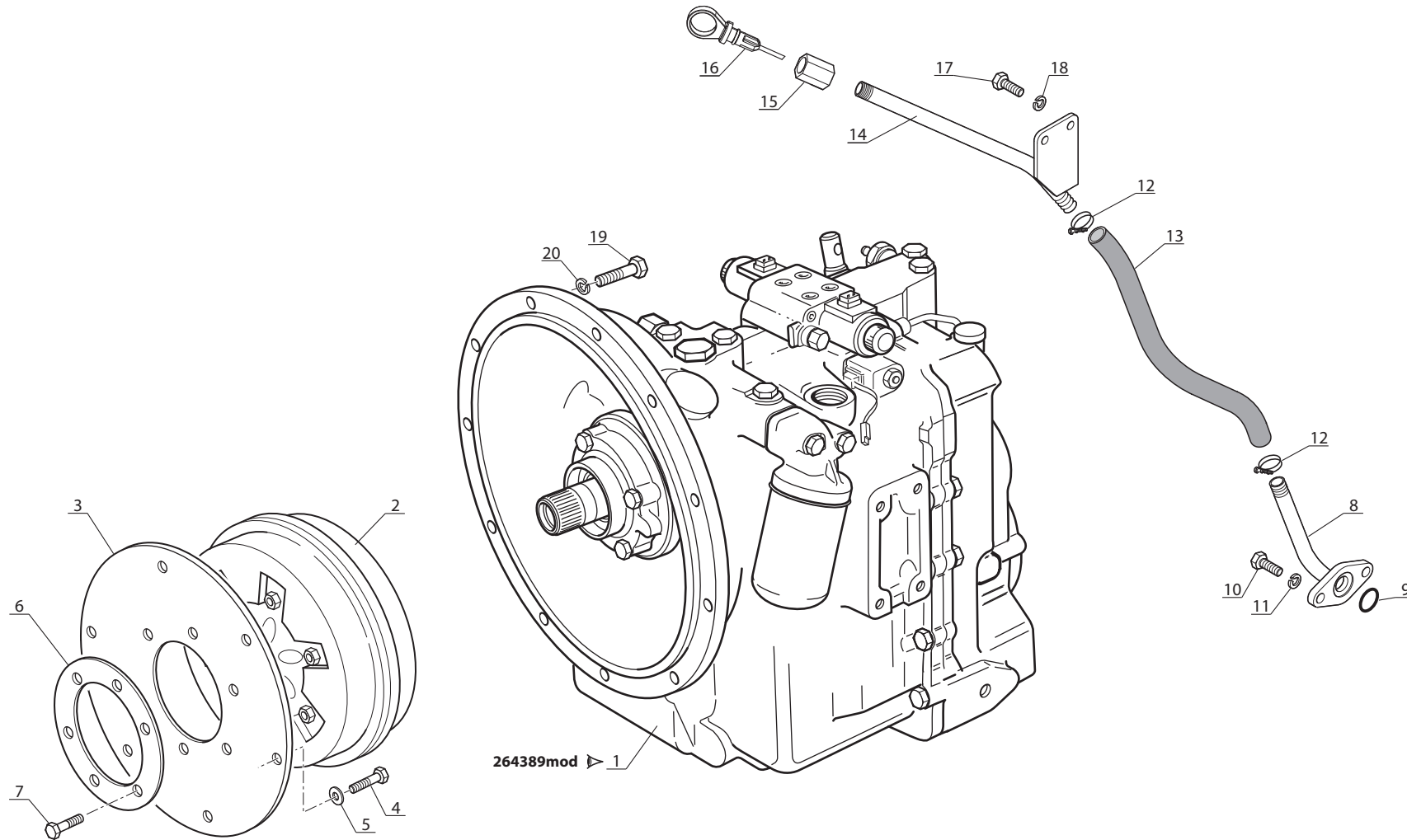

Catalogue : 647483

1	BOITE DE VITESSES ET CONVERTISSEUR GETRIEBEKASTEN UND UMFORMER CAJA DE VELOCIDADES Y CONVERTIDOR GEAR BOX AND CONVERTER CAMBIO E CONVERTITORE			Qte-Menge-Cant-Qty-Q.ta										BP 8065									
	Rep Hinw Fig Item Rif	Numéro Teil-Nr Numero Part-Nr Part-Nr	Désignation Bezeichnung Descripcion Description Descrizione	1	2	3	4	5	6	7	8	9	10	11	12	13	14	15	16	17	18	19	20
				1- M26- 2 ST3B																			
				2- M26- 4 ST3B																			
				3- M30- 2 ST3B																			
				4- M30- 4 ST3B																			
				5- M40- 2 ST3B																			
				6- M40- 4 ST3B																			
				7- M50- 2 ST3B																			
				8- M50- 4 ST3B																			
				9- M26- 2H ST3B																			
				10-M26- 4H ST3B																			
				11 - M30- 2H ST3B																			
				12 - M30- 4H ST3B																			
				13 - M40- 2H ST3B																			
				14 - M40- 4H ST3B																			
				15 - M50- 2H ST3B																			
				16 - M50- 4H ST3B																			
				17 -																			
				18 -																			
				19 -																			
				20 -																			
	1	264389	Boîte de vitesse complète Caja de velocidades completo Scàtola del cambio complete	- Kompletter getriebekasten - Complete gear box	1		1		1			1		1		1		1					
	2	209372	Convertisseur Convertidor Convertitore	- Umformer - Converter	1		1		1			1		1		1		1					
	3	209373	Plateau intermédiaire Placa intermediario Piatto intermedio	- Zwischenflansch - Intermediate piece	1		1		1			1		1		1		1					
	4	209375	Vis H,5/16-16-UNC-REF.SF161 Tornillo Vite	- Schraube - Screw	6		6		6			6		6		6		6					
	5	188544	Rondelle M 8ZN 160HV Arandela Rondella	- Unterlegscheibe - Washer	6		6		6			6		6		6		6					
	6	209374	Plateau de renfort Placa refuerzo Piatto di rinforzo	- Umformer verstärkung platte - Reinforcement plate	1		1		1			1		1		1		1					
	7	209376	Vis H,3/ 8- 13-UNF-REF.SF160 Tornillo Vite	- Schraube - Screw	6		6		6			6		6		6		6					
	8	219432	Tubulure Tobera Tubo introduttore	- Leitung - Pipe	1		1		1			1		1		1		1					
	9	4039	Joint torique Junta tórica Anello OR	- O ring - O ring	1		1		1			1		1		1		1					
	10	44807	Vis H,M12-25-8.8-ZN8/C Tornillo Vite	- Schraube - Screw	2		2		2			2		2		2		2					

M

+

Catalogue : 647483

2	BOITE DE VITESSES ET CONVERTISSEUR GETRIEBEKASTEN UND UMFORMER CAJA DE VELOCIDADES Y CONVERTIDOR GEAR BOX AND CONVERTER CAMBIO E CONVERTITORE			Qte-Menge-Cant-Qty-Q.ta										BP 8065									
	Rep Hinw Fig Item Rif	Numéro Teil-Nr Numero Part-Nr Part-Nr	Désignation Bezeichnung Descripcion Description Descrizione	1	2	3	4	5	6	7	8	9	10	11	12	13	14	15	16	17	18	19	20
11	42231	Rondelle W12 ZN Arandela Rondella	- Unterlegscheibe - Washer	2		2		2		2		2		2		2		2					
12	71940	Collier Abrazadera Fascetta	- Spannschelle - Clamp	2		2		2		2		2		2		2		2					
13	251492	Durit (Lg 255) Tubo flexible Manicotto	- Schlauch - Hose	1		1		1		1		1		1		1		1					
14	251488	Tubulure Tobera Tubo introduttore	- Leitung - Pipe	1		1		1		1		1		1		1		1					
15	252997	Embout Tapón Ghiera	- Stopfen - Plug	1		1		1		1		1		1		1		1					
16	252947	Jauge (Lg 703) Galga Livello	- Eichmass - Gauge	1		1		1		1		1		1		1		1					
17	63546	Vis H,M12-20-8.8-ZN8/C Tornillo Vite	- Schraube - Screw	2		2		2		2		2		2		2		2					
18	42231	Rondelle W12 ZN Arandela Rondella	- Unterlegscheibe - Washer	2		2		2		2		2		2		2		2					
19	63545	Vis H,M10-35-8.8-ZN8/C Tornillo Vite	- Schraube - Screw	12		12		12		12		12		12		12		12					
20	42232	Rondelle W10 ZN Arandela Rondella	- Unterlegscheibe - Washer	12		12		12		12		12		12		12		12					

M

BP 256

POUR BOITE DE VITESSE
 FÜR GETRIEBEKASTEN
 PARA CAJA DE VELOCIDADES
 FOR GEAR BOX
 PER CAMBIO

Type: **16564**
 Réf: **264 389**

BOITE DE VITESSES (Détails)
 GETRIEBEKASTEN (Einzelteile)
 CAJA DE VELOCIDADES (detalles)
 GEAR BOX (Details)
 CAMBO (Dettaglio)

M 26-2 ST3B **M 26-2H ST3B**
M 30-2 ST3B **M 30-2H ST3B**
M 40-2 ST3B **M 40-2H ST3B**
M 50-2 ST3B **M 50-2H ST3B**



→ N°:
 ↳ N°:

VOIR NOMENCLATURE *
 SIEHE STÜCKLISTE *
 VER NOMENCLATURA *
 SEE NOMENCLATURE *
 VEDERE NOMENCLATURA *

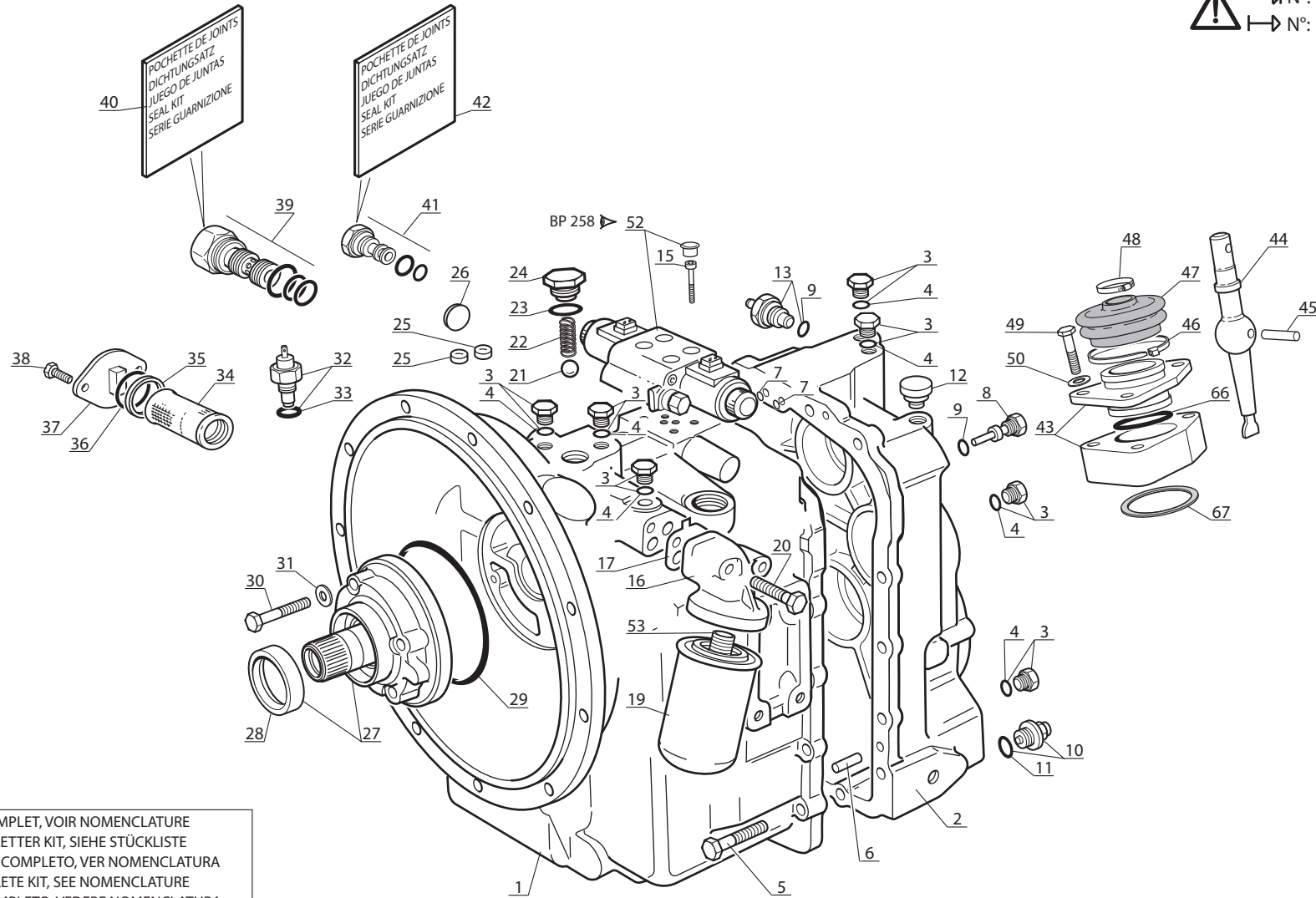

KIT COMPLET, VOIR NOMENCLATURE
 KOMPLETTER KIT, SIEHE STÜCKLISTE
 JUEGO COMPLETO, VER NOMENCLATURA
 COMPLETE KIT, SEE NOMENCLATURE
 KIT COMPLETO, VEDERE NOMENCLATURA

Rep - Hinw - Fig - Item - Sequenza
60 - 61 - 62 - 63

Catalogue : 264389MOD

Qté-Menge-Cant-Qty-Q.ta | **BP** **256** | **M**

1

BOITE DE VITESSES (Détails)
 GETRIEBKASTEN (Einzelteile)
 CAJA DE VELOCIDADES (Detalles)
 GEAR BOX (Details)
 CAMBIO (Dettaglio)

1-	264389MOD	11-
2-		12-
3-		13-
4-		14-
5-		15-
6-		16-
7-		17-
8-		18-
9-		19-
10-		20-

Rep Hinw Fig Item Rif	Numéro Teil-Nr Numero Part-Nr Part-Nr	Désignation Bezeichnung Descripcion Description Descrizione	Qté-Menge-Cant-Qty-Q.ta																			
			1	2	3	4	5	6	7	8	9	10	11	12	13	14	15	16	17	18	19	20
1	561840	Carter transmission Carter transmisión Scatola e cambio	- Transmission gehäuse - Transmission housing -	1																		
2	561841	Carter arrière transmission Carter trasero transmisión Scatola e cambio posteriore	- Transmission hinten kasten - Transmission rear case -	1																		
3	550705	Bouchon Tapón Tappo	- Stopfen - Plug -	12																		
4	109657	Joint torique Junta tórica Anello OR	- "0" ring - "0" ring -	12																		
5	109727	Vis Tornillo Vite	- Schraube - Screw -	16																		
6	109703	Goujon Espárrago Prigioniero	- Stiftschraube - Stud-bolt -	2																		
7	561833	Joint torique Junta tórica Anello OR	- "0" ring - "0" ring -	3																		
8	562823	Bouchon Tapón Tappo	- Stopfen - Plug -	1																		
9	109657	Joint torique Junta tórica Anello OR	- "0" ring - "0" ring -	1																		
10	473366	Bouchon de vidange Tapón de vaciado Tappo di scarico	- Ablassschraube - Drain plug -	1																		
11	473915	Joint torique Junta tórica Anello OR	- "0" ring - "0" ring -	1																		

+

Catalogue : 264389MOD

2

BOITE DE VITESSES (Détails)
 GETRIEBKASTEN (Einzelteile)
 CAJA DE VELOCIDADES (Detalles)
 GEAR BOX (Details)
 CAMBIO (Dettaglio)

Qté-Menge-Cant-Qty-Q.ta

BP

256

M

1-	264389MOD	11-
2-		12-
3-		13-
4-		14-
5-		15-
6-		16-
7-		17-
8-		18-
9-		19-
10-		20-

Rep Hinw Fig Item Rif	Numéro Teil-Nr Numero Part-Nr Part-Nr	Désignation Bezeichnung Descripcion Description Descrizione	Qté-Menge-Cant-Qty-Q.ta																			
			1	2	3	4	5	6	7	8	9	10	11	12	13	14	15	16	17	18	19	20
12	109705	Reniflard - Entluftung Respiradero - Air breather Sfiato -	1																			
13	705009	Mano-contact pression huile transmission Ol transmission druckschalter Mano contacto presión de aceite transmisión Transm oil pressure switch Interruttore pressione olio trasmissione	1																			
15	561829	Vis - Schraube Tornillo - Screw Vite -	4																			
16	561837	Carter filtre - Filter gehäuse Carter filtro - Filter housing Carter filtro -	1																			
17	109646	Joint plat - Dichtung Junta plana - Gasket Guarnizióne -	1																			
19	561749	Filtre à huile transmission - Ol filter getriebe Filtro aceite transmisión - Oil filter transmission Filtro olio trasmissione -	1																			
20	748347	Vis - Schraube Tornillo - Screw Vite -	2																			
21	561836	Bille - Kugel Bola - Ball Sfera -	1																			
22	561765	Ressort - Feder Muelle - Spring Molla -	1																			
23	561827	Joint torique - "O" ring Junta tórica - "O" ring Anello OR -	1																			
24	748346	Bouchon - Stopfen Tapón - Plug Tappo -	1																			

+

Catalogue : 264389MOD

3

BOITE DE VITESSES (Détails)
 GETRIEBKASTEN (Einzelteile)
 CAJA DE VELOCIDADES (Detalles)
 GEAR BOX (Details)
 CAMBIO (Dettaglio)

Qté-Menge-Cant-Qty-Q.ta

BP

256

M

1-	264389MOD	11-
2-		12-
3-		13-
4-		14-
5-		15-
6-		16-
7-		17-
8-		18-
9-		19-
10-		20-

Rep Hinw Fig Item Rif	Numéro Teil-Nr Numero Part-Nr Part-Nr	Désignation Bezeichnung Descripcion Description Descrizione	Qté-Menge-Cant-Qty-Q.ta																			
			1	2	3	4	5	6	7	8	9	10	11	12	13	14	15	16	17	18	19	20
25	561822	Bouchon Tapón Tappo	- Stopfen - Plug -	2																		
26	561834	Bouchon d'expansion Tapón Tappo	- Stopfen - Plug -	1																		
27	561930	Pompe complète Bomba completa Pompa completa	- Kompletter Pumpe - Complete Pump -	1																		
28	109690	Joint d'étanchéité Junta de estanqueidad Guarnizióne	- Dichtungsring - Seal -	1																		
29	109676	Joint torique Junta tórica Anello OR	- "0" ring - "0" ring -	1																		
30	561760	Vis Tornillo Vite	- Schraube - Screw -	4																		
31	564381	Rondelle Arandela Rondella	- Unterlegscheibe - Washer -	4																		
32	702388	Sonde de température huile Sonda de temperatura de aceite- Sonda temperatura olio	- Öl temperatur transmitter - Oil temperature sensor -	1																		
33	109657	Joint torique Junta tórica Anello OR	- "0" ring - "0" ring -	1																		
34	109565	Crépine d'aspiration Alcachofa de aspiración Pigna d'aspirazione	- Ansaugen seihe - Suction strainer -	1																		
35	550626	Rondelle Arandela Rondella	- Unterlegscheibe - Washer -	1																		

+

Catalogue : 264389MOD

Qté-Menge-Cant-Qty-Q.ta | BP 256 | M

4

BOITE DE VITESSES (Détails)
 GETRIEBKASTEN (Einzelteile)
 CAJA DE VELOCIDADES (Detalles)
 GEAR BOX (Details)
 CAMBIO (Dettaglio)

1-	264389MOD	11-
2-		12-
3-		13-
4-		14-
5-		15-
6-		16-
7-		17-
8-		18-
9-		19-
10-		20-

Rep Hinw Fig Item Rif	Numéro Teil-Nr Numero Part-Nr Part-Nr	Désignation Bezeichnung Descripcion Description Descrizione	Qté-Menge-Cant-Qty-Q.ta																			
			1	2	3	4	5	6	7	8	9	10	11	12	13	14	15	16	17	18	19	20
36	550627	Joint torique - "0" ring Junta tórica - "0" ring Anello OR -	1																			
37	473368	Couvercle - Deckel Tapadera - Cover Coperchio -	1																			
38	748351	Vis - Schraube Tornillo - Screw Vite -	2																			
39	561830	Valve (Régulateur de pression) - Ventil (Druckregulierung) Válvula (Ajuste presión) - Valve (Pressure regulation) Valvola (Regolatore) -	1																			
40	561946	Pochette de joints - Dichtungssatz Juego de juntas - Seal kit Serie guarnizióne -	1																			
41	561823	Clapet de surpression - Druck ventil Válvula de superpresión - Over pressure valve Valvola di sovrappresione -	1																			
42	561945	Pochette de joints - Dichtungssatz Juego de juntas - Seal kit Serie guarnizióne -	1																			
43	562040	Siège supérieur - Ober Sitz Asiento superior - Upper seat Sedille superiore -	1																			
44	561816	Pied de levier de vitesses - Schalthebel fuss Pie de palanca de velocidades - Gear lever foot Braccio leva del cambio -	1																			
45	109681	Goupille - Stift Pasador - Pin Spina -	1																			
46	561820	Collier - Spannschelle Abrazadera - Clamp Fascetta -	1																			

+

Catalogue : 264389MOD

Qté-Menge-Cant-Qty-Q.ta

BP

256

M

5

BOITE DE VITESSES (Détails)
 GETRIEBKASTEN (Einzelteile)
 CAJA DE VELOCIDADES (Detalles)
 GEAR BOX (Details)
 CAMBIO (Dettaglio)

1-	264389MOD	11-
2-		12-
3-		13-
4-		14-
5-		15-
6-		16-
7-		17-
8-		18-
9-		19-
10-		20-

Rep Hinw Fig Item Rif	Número Teil-Nr Numero Part-Nr Part-Nr	Désignation Bezeichnung Descripcion Description Descrizione																				
			1	2	3	4	5	6	7	8	9	10	11	12	13	14	15	16	17	18	19	20
47	109612	Cache poussière Guardapolvo Coperchio raschiapolvere	- Staubschützer - Dust cover -	1																		
48	561821	Collier Abrazadera Fascetta	- Spannschelle - Clamp -	1																		
49	561760	Vis Tornillo Vite	- Schraube - Screw -	3																		
50	561761	Rondelle Arandela Rondella	- Unterlegscheibe - Washer -	3																		
52	702639	Valve de contrôle électrique Válvula de control electrico Valvola di controllo elettrico-	- Elektrische kontrollventil - Electrical control valve -	1																		
53	705954	Raccord Racor Raccordo	- Verschraubung - Connection -	1																		
60	561931	Kit pompe Kit bomba Kit pompa	- Kit pumpe - Pump kit -	X																		
61	561934	Kit petites pièces Juego pequeñas piezas Kit piccoli pezzi	- Einzelteile satz - Small parts kit -	X																		
62	562002	Pochette de joints Juego de juntas Serie guarnizióne	- Dichtungssatz - Seal kit -	X																		
63	562003	Pochette de joints Juego de juntas Serie guarnizióne	- Dichtungssatz - Seal kit -	X																		
66	600365	Joint plat Junta plana Guarnizióne	- Dichtung - Gasket -	1																		

+

Catalogue : 264389MOD

6

BOITE DE VITESSES (Détails)
 GETRIEBKASTEN (Einzelteile)
 CAJA DE VELOCIDADES (Detalles)
 GEAR BOX (Details)
 CAMBIO (Dettaglio)

Qté-Menge-Cant-Qty-Q.ta

BP

256

M

1-	264389MOD	11-
2-		12-
3-		13-
4-		14-
5-		15-
6-		16-
7-		17-
8-		18-
9-		19-
10-		20-

Rep Hinw Fig Item Rif	Numéro Teil-Nr Numero Part-Nr Part-Nr	Désignation Bezeichnung Descripcion Description Descrizione
-----------------------------------	---	---

1	2	3	4	5	6	7	8	9	10	11	12	13	14	15	16	17	18	19	20
---	---	---	---	---	---	---	---	---	----	----	----	----	----	----	----	----	----	----	----

67	600366	<p>Joint torique - "0" ring Junta tórica - "0" ring Anello OR -</p> <p>* M26-2 Série 3 M30-2 Série 3 MC 30 Série 3</p> <p>A PARTIR DE LA MACHINE N° 253625 AB DER MASCHINE N° 253625 A PARTIR DE LA MAQUINA N° 253625 FROM MACHINE N° 253625 A PARTIR DA MACCHINA N° 253625</p> <p>* Composition des Kits Kitzusammensetzung Composición de los conjuntos Kits composition Composizione kit</p> <p>- 561931 = Rep,Hinw,Fig,Item 27,29,31</p> <p>- 561934 = Rep,Hinw,Fig,Item 3,21,22,45,46,47,48 (BP256) + 54,55,56 (BP 257)</p> <p>- 562002 = Rep,Hinw,Fig,Item 49,57,80 (BP257) + 4,7,11,23,36 (BP 256)</p> <p>- 562003 = Rep,Hinw,Fig,Item 25,26,28,29,31 (BP256) + 6,40,47 (BP 257)</p>
----	--------	--

1																				
---	--	--	--	--	--	--	--	--	--	--	--	--	--	--	--	--	--	--	--	--

BP 257

POUR BOITE DE VITESSES
FÜR GETRIEBEKASTEN
PARA CAJA DE VELOCIDADES
FOR GEAR BOX
PER CAMBIO

□ Type: **16 564**
□ Ref: **264 389**

BOITE DE VITESSES (Détails
mécanismes - Pignonnerie)
GETRIEBEKASTEN (Mechanismus
einzelteile - Zahnrad)
CAJA DE VELOCIDADES (Detalles
mecanismo - Pinón)

GEAR BOX (Mechanism details - Gear)
CAMBIO (Particolari Meccanici - Pignone)

M 26-2 ST3B **M 26-2H ST3B**
M 30-2 ST3B **M 30-2H ST3B**
M 40-2 ST3B **M 40-2H ST3B**
M 50-2 ST3B **M 50-2H ST3B**

KIT COMPLET, VOIR NOMENCLATURE
KOMPLETTER KIT, SIEHE STÜCKLISTE
JUEGO COMPLETO, VER NOMENCLATURA
COMPLETE KIT, SEE NOMENCLATURE
KIT COMPLETO, VEDERE NOMENCLATURA

Rep - Hinw - Fig - Item - Seqenza
70 - 71 - 72 - 73 - 74 - 75 - 76
77 - 78



→ N°:
→ N°:

VOIR NOMENCLATURE *
SIEHE STÜCKLISTE *
VER NOMENCLATURA *
SEE NOMENCLATURE *
VEDERE NOMENCLATURA *

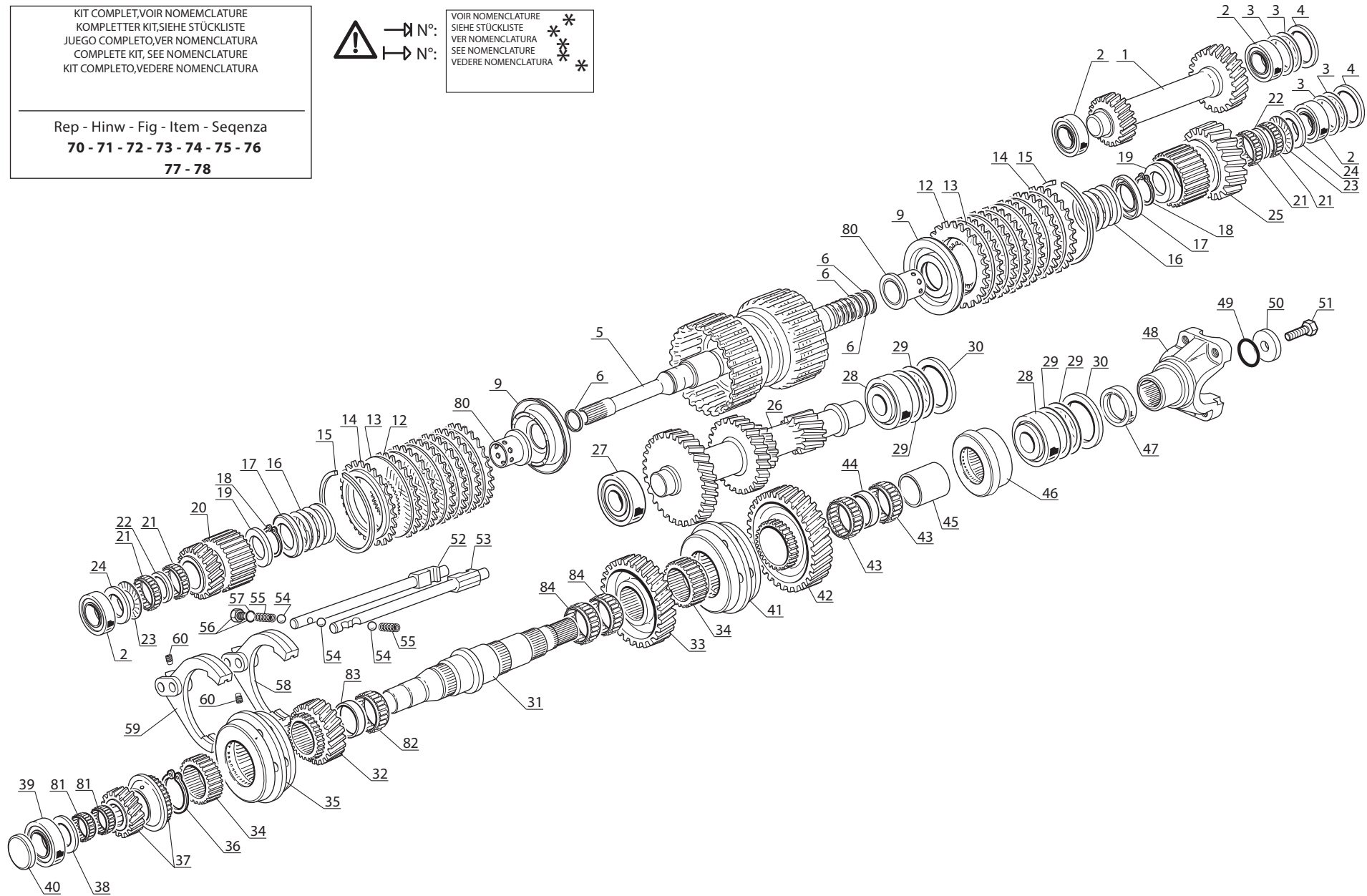

Catalogue : 264389MOD

Qté-Menge-Cant-Qty-Q.ta

BP

257

M

1

BOITE DE VITESSES (Détails mécanismes - Pignonnerie)
 GETRIEBKASTEN (Mechanismus einzelteile - Zahnrad)
 CAJA DE VELOCIDADES (Detalles mecanismo - Piñón)
 GEAR BOX (Mechanism details - Gear)
 CAMBIO (Particolari meccanici - Pignone)

1-	264389MOD	11-
2-		12-
3-		13-
4-		14-
5-		15-
6-		16-
7-		17-
8-		18-
9-		19-
10-		20-

Rep Hinw Fig Item Rif	Numéro Teil-Nr Numero Part-Nr Part-Nr	Désignation Bezeichnung Descripcion Description Descrizione																				
			1	2	3	4	5	6	7	8	9	10	11	12	13	14	15	16	17	18	19	20
1	561791	Pignon d'inverseur Piñón de inversor Ingranaggio di invertitore	- Umstellzahnrad - Reverse idler gear -	1																		
2	109701	Roulement Rodamiento Cuscinetto	- Lager - Bearing -	4																		
3	109615	Cale d'épaisseur 0,051 mm Cala de espesor Spessore	- Ausgleichscheibe - Shim -	X																		
3	109616	Cale d'épaisseur 0,076 mm Cala de espesor Spessore	- Ausgleichscheibe - Shim -	X																		
3	109617	Cale d'épaisseur 0,127 mm Cala de espesor Spessore	- Ausgleichscheibe - Shim -	X																		
3	109618	Cale d'épaisseur 0,178 mm Cala de espesor Spessore	- Ausgleichscheibe - Shim -	X																		
3	109619	Cale d'épaisseur 0,381 mm Cala de espesor Spessore	- Ausgleichscheibe - Shim -	X																		
3	109620	Cale d'épaisseur 0,508 mm Cala de espesor Spessore	- Ausgleichscheibe - Shim -	X																		
4	109597	Entretoise Separador Distanziale	- Querstrebe - Spacer -	2																		
5	602729	Arbre d'entrée Arbol de entrada Albero di entrato	- Antriebswelle - Input shaft -	1																		
6	109624	Joint d'étanchéité Junta de estanqueidad Guarnizióne	- Dichtungsring - Seal -	4																		

+

Catalogue : 264389MOD

Qté-Menge-Cant-Qty-Q.ta | **BP** **257** | **M**

2

BOITE DE VITESSES (Détails mécanismes - Pignonnerie)
 GETRIEBKASTEN (Mechanismus einzelteile - Zahnrad)
 CAJA DE VELOCIDADES (Detalles mecanismo - Piñón)
 GEAR BOX (Mechanism details - Gear)
 CAMBIO (Particolari meccanici - Pignone)

1-	264389MOD	11-
2-		12-
3-		13-
4-		14-
5-		15-
6-		16-
7-		17-
8-		18-
9-		19-
10-		20-

Rep Hinw Fig Item Rif	Numéro Teil-Nr Numero Part-Nr Part-Nr	Désignation Bezeichnung Descripcion Description Descrizione																				
			1	2	3	4	5	6	7	8	9	10	11	12	13	14	15	16	17	18	19	20
9	702819	Kit piston Kit pistón Kit pistone	- Kolben kit - Piston kit -	2																		
12	561797	Disque d'embrayage Disco de embrague Disco d'innesto	- Kupplung disk - Clutch disc -	12																		
13	561798	Disque de friction Disco de fricción Disco frizione	- Reibung disk - Friction disc -	12																		
14	561796	Plateau Placa Piatto	- Platte - Plate -	2																		
15	561795	Circlips Aro retén Anello elastico	- Sicherungsring - Circlip -	2																		
16	561801	Ressort Muelle Molla	- Feder - Spring -	2																		
17	561800	Bague Anillo Anello	- Büchse - Bushing -	2																		
18	561799	Circlips Aro retén Anello elastico	- Sicherungsring - Circlip -	2																		
19	561789	Rondelle de poussée Arandela de presión Rondella	- Druck unterlegscheibe - Thrustwasher -	2																		
20	561793	Pignon primaire marche avant Piñón primario marcha adelante Ingranaggio primario marcia avanti	- Vorwärtsgang primär zahnrad - Forward primary gear -	1																		
21	109651	Roulement à aiguilles Rodamiento de agujas Cuscinetto	- Rollenlager - Roller bearing -	4																		

+

Catalogue : 264389MOD

3

BOITE DE VITESSES (Détails mécanismes - Pignonnerie)
 GETRIEBKASTEN (Mechanismus einzelteile - Zahnrad)
 CAJA DE VELOCIDADES (Detalles mecanismo - Piñón)
 GEAR BOX (Mechanism details - Gear)
 CAMBIO (Particolari meccanici - Pignone)

Qté-Menge-Cant-Qty-Q.ta

BP

257

M

1-	264389MOD	11-
2-		12-
3-		13-
4-		14-
5-		15-
6-		16-
7-		17-
8-		18-
9-		19-
10-		20-

Rep Hinw Fig Item Rif	Numéro Teil-Nr Numero Part-Nr Part-Nr	Désignation Bezeichnung Descripcion Description Descrizione																				
			1	2	3	4	5	6	7	8	9	10	11	12	13	14	15	16	17	18	19	20
22	561809	Entretoise - Querstrebe Separador - Spacer Distanziale -	2																			
23	561762	Roulement - Läger Rodamiento - Bearing Cuscinetto -	2																			
24	561764	Rondelle de butée - Anschlagunterlegscheibe Arandela de tope - Stop washer Rondella reggisp -	2																			
25	561794	Pignon primaire marche arrière (27 dents) Rückwärtsgang primär Zahnrad Piñón primario marcha atrás - Backward primary gear Pignone primario retro-marcia -	1																			
26	561790	Arbre de renvoi - Vorgelegewelle Arbo de reenvio - Countershaft Albero di rinvio -	1																			
27	109622	Roulement - Läger Rodamiento - Bearing Cuscinetto -	1																			
28	561786	Roulement - Läger Rodamiento - Bearing Cuscinetto -	2																			
29	109599	Cale d'épaisseur 0,051 mm - Ausgleichscheibe Cala de espesor - Shim Spessore -	X																			
29	109600	Cale d'épaisseur 0,076 mm - Ausgleichscheibe Cala de espesor - Shim Spessore -	X																			
29	109601	Cale d'épaisseur 0,178 mm - Ausgleichscheibe Cala de espesor - Shim Spessore -	X																			
29	109602	Cale d'épaisseur 0,559 mm - Ausgleichscheibe Cala de espesor - Shim Spessore -	X																			

+

Catalogue : 264389MOD

BOITE DE VITESSES (Détails mécanismes - Pignonnerie)
 GETRIEBKASTEN (Mechanismus einzelteile - Zahnrad)
 CAJA DE VELOCIDADES (Detalles mecanismo - Piñón)
 GEAR BOX (Mechanism details - Gear)
 CAMBIO (Particolari meccanici - Pignone)

Qté-Menge-Cant-Qty-Q.ta

BP 257

M

Rep Hinw Fig Item Rif	Numéro Teil-Nr Numero Part-Nr Part-Nr	Désignation Bezeichnung Descripcion Description Descrizione	Qté-Menge-Cant-Qty-Q.ta																								
			1	2	3	4	5	6	7	8	9	10	11	12	13	14	15	16	17	18	19	20					
4			1- 264389MOD	11-																							
			2-	12-																							
			3-	13-																							
			4-	14-																							
			5-	15-																							
			6-	16-																							
			7-	17-																							
			8-	18-																							
			9-	19-																							
			10-	20-																							
30	109598	Entretoise Separador Distanziale	- Querstrebe - Spacer -		2																						
31	746716	Arbre de sortie Arbol de salida Albero di uscita	- Ausgangs welle - Out put shaft -		1																						
32	748349	Pignon 3ème vitesse Piñón 3ra velocidad Ingranaggio 3° marcia	- Zahnrad 3ten gang - 3rd gear -		1																						
33	748350	Pignon 2ème vitesse Piñón 2da velocidad Ingranaggio 2° marcia	- Zahnrad 2te gang - 2nd gear -		1																						
34	109586	Manchon cannelé Manguito acanalado Manicotto	- Kupplungsmuffe - Coupling sleeve -		2																						
35	109665	Ensemble synchro Conjunto sincrón Insieme sincronizzazione	- Kompletter Drehmelder - Synchro assy -		1																						
36	109664	Circlips Aro retén Anello elastico	- Sicherungsring - Circlip -		1																						
37	748348	Pignon 4ème vitesse Piñón 4ta velocidad Ingranaggio 4° marcia	- Zahnrad 4ten gang - 4th gear -		1																						
38	561784	Rondelle Arandela Rondella	- Unterlegscheibe - Washer -		1																						
39	561788	Roulement Rodamiento Cuscinetto	- Lager - Bearing -		1																						
40	550632	Bouchon Tapón Tappo	- Stopfen - Plug -		1																						



Catalogue : 264389MOD

Qté-Menge-Cant-Qty-Q.ta

BP

257

M

5

BOITE DE VITESSES (Détails mécanismes - Pignonnerie)
 GETRIEBKASTEN (Mechanismus einzelteile - Zahnrad)
 CAJA DE VELOCIDADES (Detalles mecanismo - Piñón)
 GEAR BOX (Mechanism details - Gear)
 CAMBIO (Particolari meccanici - Pignone)

1-	264389MOD	11-
2-		12-
3-		13-
4-		14-
5-		15-
6-		16-
7-		17-
8-		18-
9-		19-
10-		20-

Rep Hinw Fig Item Rif	Numéro Teil-Nr Numero Part-Nr Part-Nr	Désignation Bezeichnung Descripcion Description Descrizione	1	2	3	4	5	6	7	8	9	10	11	12	13	14	15	16	17	18	19	20
41	109665	Ensemble synchro - Kompletter Drehmelder Conjunto sincrón - Synchro assy Insieme sincronizzazione -	1																			
42	109568	Pignon lère vitesse (43 dents) - Zahnrad lten gang Piñón lra velocidad - Out put shaft 1st gear Ingranaggio 1° marcia -	1																			
43	109621	Roulement - Läger Rodamiento - Bearing Cuscinetto -	2																			
44	109653	Entretoise - Querstrebe Separador - Spacer Distanziale -	1																			
45	109652	Manchon - Muffe Manguito - Coupling Manicotto -	1																			
46	551373	Entretoise - Querstrebe Separador - Spacer Distanziale -	1																			
47	781700	Joint d'étanchéité - Dichtring Junta de estanqueidad - Seal Guarnizione di tenuta -	1																			
48	561807	Chape d'accouplement - Gabelkupplung Horquilla de acoplamiento - End yoke Forcella -	1																			
49	550636	Joint torique - "O" ring Junta tórica - "O" ring Anello OR -	1																			
50	109798	Rondelle - Unterlegscheibe Arandela - Washer Rondella -	1																			
51	561810	Vis - Schraube Tornillo - Screw Vite -	1																			

+

Catalogue : 264389MOD

6

BOITE DE VITESSES (Détails mécanismes - Pignonnerie)
 GETRIEBKASTEN (Mechanismus einzelteile - Zahnrad)
 CAJA DE VELOCIDADES (Detalles mecanismo - Piñón)
 GEAR BOX (Mechanism details - Gear)
 CAMBIO (Particolari meccanici - Pignone)

Qté-Menge-Cant-Qty-Q.ta

BP

257

M

1-	264389MOD	11-
2-		12-
3-		13-
4-		14-
5-		15-
6-		16-
7-		17-
8-		18-
9-		19-
10-		20-

Rep Hinw Fig Item Rif	Numéro Teil-Nr Numero Part-Nr Part-Nr	Désignation Bezeichnung Descripcion Description Descrizione																				
			1	2	3	4	5	6	7	8	9	10	11	12	13	14	15	16	17	18	19	20
52	561814	Coulisseau de 1ère et 2ème - Führung 1ten und 2ten Riel cambio velocidades 1ra y 2ra 1st and 2nd shift rod Guida 1 e 2 -	1																			
53	561815	Coulisseau de 3ème et 4ème - Führung 3ten und 4ten Riel cambio velocidades 3ra y 4ra 3rd and 4th shift rod Guida 3 e 4 -	1																			
54	109709	Bille - Kugel Bola - Ball Sfera -	3																			
55	473920	Ressort - Feder Muelle - Spring Molla -	2																			
56	550705	Bouchon - Stopfen Tapón - Plug Tappo -	1																			
57	109657	Joint torique - "O" ring Junta tórica - "O" ring Anello OR -	1																			
58	561812	Fourchette 1ère et 2ème - Gabel 1ten und 2ten Horquilla 1ra y 2da - 1st and 2nd shift fork Forcella 1 e 2 -	1																			
59	561813	Fourchette 3ème et 4ème - Gabel 3ten und 4ten Horquilla 3ra y 4ra - 3rd and 4th shift fork Forcella 3 e 4 -	1																			
60	109737	Vis - Schraube Tornillo - Screw Vite -	2																			
70	705892	Kit embrayage - Kupplungsatz Juego de embrague - Clutch pack kit Kit innesto -	X																			
71	703472	Kit embrayage complet - Kompletter Kupplungsatz Juego de embrague completo - Complete clutch pack kit Kit innesto completo -	X																			

+

Catalogue : 264389MOD

Qté-Menge-Cant-Qty-Q.ta

BP

257

M

7

BOITE DE VITESSES (Détails mécanismes - Pignonnerie)
 GETRIEBKASTEN (Mechanismus einzelteile - Zahnrad)
 CAJA DE VELOCIDADES (Detalles mecanismo - Piñón)
 GEAR BOX (Mechanism details - Gear)
 CAMBIO (Particolari meccanici - Pignone)

1-	264389MOD	11-
2-		12-
3-		13-
4-		14-
5-		15-
6-		16-
7-		17-
8-		18-
9-		19-
10-		20-

Rep Hinw Fig Item Rif	Numéro Teil-Nr Numero Part-Nr Part-Nr	Désignation Bezeichnung Descripcion Description Descrizione	Qté-Menge-Cant-Qty-Q.ta																			
			1	2	3	4	5	6	7	8	9	10	11	12	13	14	15	16	17	18	19	20
72	561934	Kit petites pièces Juego pequeñas piezas Kit piccoli pezzi	- Einzelteile satz - Small parts kit -	X																		
73	562001	Jeu de roulement Juego cojinete Kit cuscinetto	- Lagersatz - Bearing kit -	X																		
74	562002	Pochette de joints Juego de juntas Serie guarnizióne	- Dichtungssatz - Seal kit -	X																		
75	562003	Pochette de joints Juego de juntas Serie guarnizióne	- Dichtungssatz - Seal kit -	X																		
76	562004	Jeu de circlips Juego de aro retén Kit anello elastico	- Sicherungsring satz - Circlip kit -	X																		
77	562005	Jeu de rondelles Juego de arandelas Kit rondella	- Unterlagscheibesatz - Washer kit -	X																		
78	561940	Jeu de rondelles de poussée Juego de arandela de presión Kit rondella	- Druckscheibe satz - Thrust washer kit -	X																		
80	602730	Bague Anillo Anello	- Büchse - Bushing -	2																		
81	109651	Roulement à aiguilles Rodamiento de agujas Cuscinetto	- Rollenlager - Roller bearing -	2																		
82	564454	Roulement à aiguilles Rodamiento de agujas Cuscinetto	- Rollenlager - Roller bearing -	1																		
83	746717	Rondelle Arandela Rondella	- Unterlegscheibe - Washer -	1																		

+

Catalogue : 264389MOD

8

BOITE DE VITESSES (Détails mécanismes - Pignonnerie)
 GETRIEBKASTEN (Mechanismus einzelteile - Zahnrad)
 CAJA DE VELOCIDADES (Detalles mecanismo - Piñón)
 GEAR BOX (Mechanism details - Gear)
 CAMBIO (Particolari meccanici - Pignone)

Qté-Menge-Cant-Qty-Q.ta

BP

257

M

1-	264389MOD	11-
2-		12-
3-		13-
4-		14-
5-		15-
6-		16-
7-		17-
8-		18-
9-		19-
10-		20-

Rep Hinw Fig Item Rif	Numéro Teil-Nr Numero Part-Nr Part-Nr	Désignation Bezeichnung Descripcion Description Descrizione
84	109621	<p>Roulement - Läger Rodamiento - Bearing Cuscinetto -</p> <p>* M26-2 Série 3 M30-2 Série 3 MC 30 Série 3</p> <p>A PARTIR DE LA MACHINE N° 253625 AB DER MASCHINE N° 253625 A PARTIR DE LA MAQUINA N° 253625 FROM MACHINE N° 253625 A PARTIR DA MACCHINA N° 253625</p> <p>* Composition des Kits Kitzusammensetzung Composición de los conjuntos Kits composition Composizione kit</p> <p>- 705892 = Rep,Hinw,Fig,Item 9,12,13,14,15,16,17,18,80 - 703472 = Rep,Hinw,Fig,Item 5 (BP257) + kit 70 - 561934 = Rep,Hinw,Fig,Item 3,21,22,45,46,47,48 (BP256) + 54,55,56 (BP257) - 561940 = Rep,Hinw,Fig,Item 19,24,38 - 562001 = Rep,Hinw,Fig,Item 35 (BP256) + 2,21,23,27,28,39,43,45 (BP257) - 562002 = Rep,Hinw,Fig,Item 49,57,80 (BP257) + 4,7,11,23,36 (BP256) - 562003 = Rep,Hinw,Fig,Item 25,26,28,29,31 (BP256) + 6,40,47 (BP257) - 562004 = Rep,Hinw,Fig,Item 15,18,36 - 562005 = Rep,Hinw,Fig,Item 3,29</p>

1	2	3	4	5	6	7	8	9	10	11	12	13	14	15	16	17	18	19	20
2																			

BP 203

VALVE DE CONTROLE ELECTRIQUE
 ELEKTRISCHE KONTROLLVENTIL
 VALVULA DE CONTROL ELECTRICA
 ELECTRICAL CONTROL VALVE
 VAVOLA DI CONTROLLO ELLETTRICO

M 26-2 ST3B **M 26-2H ST3B**
M 30-2 ST3B **M 30-2H ST3B**
M 40-2 ST3B **M 40-2H ST3B**
M 50-2 ST3B **M 50-2H ST3B**

POUR BOITE DE VITESSE
 FÜR GETREIBEKASTEN
 PARA CAJA DE VELOCIDADES
 FOR GEAR BOX
 PER CAMBIO

A PARTIR DE LA BOITE DE VITESSE
 AB DER GETREIBEKASTEN
 A PARTIR DE LA CAJA DE VELOCIDADES
 FROM GEAR BOX
 A PARTIR DEL CAMBIO



→ N°:
 ↳ N°:

VOIR NOMENCLATURE
 SIEHE STÜCKLISTE
 VER NOMENCLATURA
 SEE NOMENCLATURA
 VEDERE NOMENCLATURA



NON LIVRE AVEC REP. 1
 NICHT GELIEFERT MIT HINW. 1
 NO ENTREGADOS CON FIG. 1
 NOT DELIVERED WITH ITEM. 1
 NO CONSEGNARE CON SEQU. 1

■ KIT COMPLET, VOIR NOMENCLATURE
 KOMPLETTER KIT, SIEHE STÜCKLISTE
 JUEGO COMPLETO, VER NOMENCLATURA
 COMPLETE KIT, SEE NOMENCLATURA
 KIT COMPLETO, VEDERE NOMENCLATURA

Rep - Hinw - Fig - Item - Sequenza
8

- | | | |
|---|---------------------|--------------------------|
| <input type="checkbox"/> Type: 15984 | Réf: 222 572 | ↳ N°: G03 - 2639 |
| <input type="checkbox"/> Type: 15985 | Réf: 222 573 | ↳ N°: G03 - 2208 |
| <input type="checkbox"/> Type: 16025 | Réf: 226 228 | ↳ N°: G03 - 14975 |
| <input type="checkbox"/> Type: 16024 | Réf: 226 229 | ↳ N°: G03 - 10170 |
| <input type="checkbox"/> Type: 16097 | Réf: 232 444 | ↳ N°: G03 - 1253 |
| <input type="checkbox"/> Type: 16335 | Réf: 247 596 | |
| <input type="checkbox"/> Type: 16486 | Réf: 258 799 | |
| <input type="checkbox"/> Type: 16486 | Réf: 258 800 | |
| <input type="checkbox"/> Type: 16564 | Réf: 264 389 | |
| <input type="checkbox"/> Type: 16568 | Réf: 264 390 | |
| <input type="checkbox"/> Type: 16566 | Réf: 264 391 | |

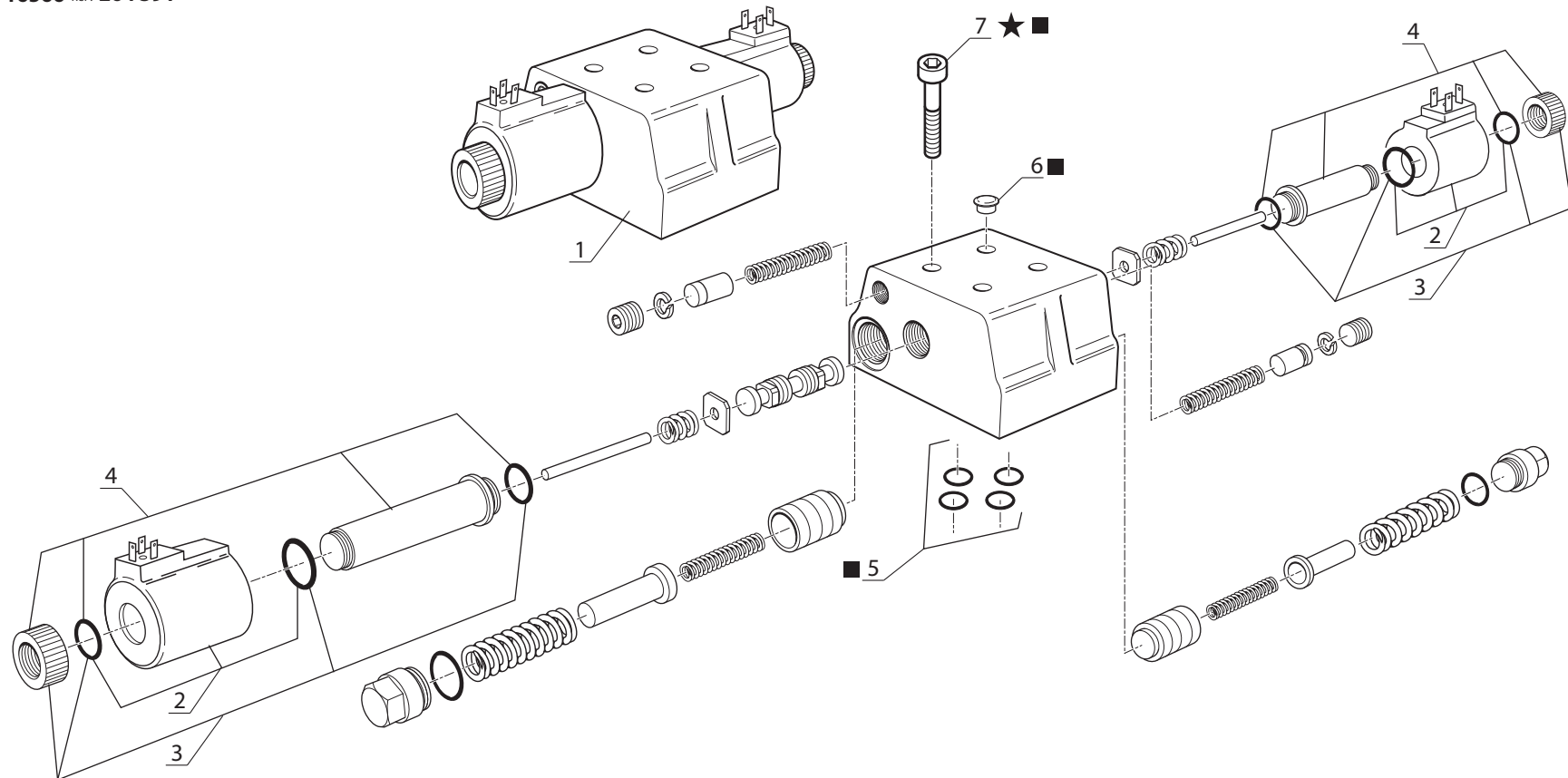

Catalogue : 264390MOD

Qté-Menge-Cant-Qty-Q.ta | **BP** | **203** | **M**

1	VALVE DE CONTROLE ELECTRIQUE ELEKTRISCHE KONTROLLVENTIL VALVULA DE CONTROL ELECTRICO ELECTRICAL CONTROL VALVE VALVOLA DI CONTROLLO ELLETTRICO			11- 264390MOD 12- 13- 14- 15- 16- 17- 18- 19- 20-																			
	Rep Hinw Fig Item Rif	Numéro Teil-Nr Numero Part-Nr Part-Nr	Désignation Bezeichnung Descripcion Description Descrizione	1	2	3	4	5	6	7	8	9	10	11	12	13	14	15	16	17	18	19	20
1	702639	Valve de contrôle électrique - Elektrische kontrollventil Válvula de control electrico - Electrical control valve Valvola di controllo elettrico-	1																				
2	702381	Solénoïde - Solenoid Solenoid - Solenoid Solenoid -	2																				
3	702382	Kit petites pièces - Einzelteile satz Juego pequeña piezas - Small parts kit Kit piccoli pezzi -	2																				
4	702383	Support solénoïde - Solenoid tr�ager Soporte solenoide - Solenoid bracket Supporto solenoide -	2																				
5	561943	Pochette de joints - Dichtungssatz Juego de juntas - Seal kit Serie guarnizi�one -	1																				
6	562043	Bouchon - Stopfen Tap�n - Plug Tappo -	4																				
7	561829	Vis - Schraube Tornillo - Screw Vite -	4																				
8	702384	Kit petites pi�ces - Einzelteile satz Juego peque�a piezas - Small parts kit Kit piccoli pezzi - * M26-4 S�rie 3 M30-4 S�rie 3 M40-4 S�rie 3 M50-4 S�rie 3 A PARTIR DE LA MACHINE 253873 AB DER MASCHINE 253873 A PARTIR DE LA MAQUINA 253873 FROM MACHINE 253873 A PARTIR DA MACCHINA 253873	1																				

BOITE DE VITESSES - GETRIEBEKASTEN

CAJA DE VELOCIDADES - GEAR BOX

CAMBIO

TYPE - TYPEN

TIPO - TYPE

TIPO

16568

REFERENCE - NUMMER

NUMERO - NUMBER

RIFERIMENTO

264 390

BP 8066

POUR BOITE DE VITESSES
FÜR GETRIEBKASTEN
PARA CAJA DE VELOCIDADES
FOR GEAR BOX
PER CAMBIO

Type: **16 568**

Ref: **264 390**

BOITE DE VITESSES ET CONVERTISSEUR
GETRIEBKASTEN UND UMFORMER
CAJA DE VELOCIDADES Y CONVERTIDOR
GEAR BOX AND CONVERTER
CAMBIO E CONVERTITORE

M 26-4 ST3B

M 30-4 ST3B

M 40-4 ST3B

M 50-4 ST3B

M 26-4H ST3B

M 30-4H ST3B

M 40-4H ST3B

M 50-4H ST3B

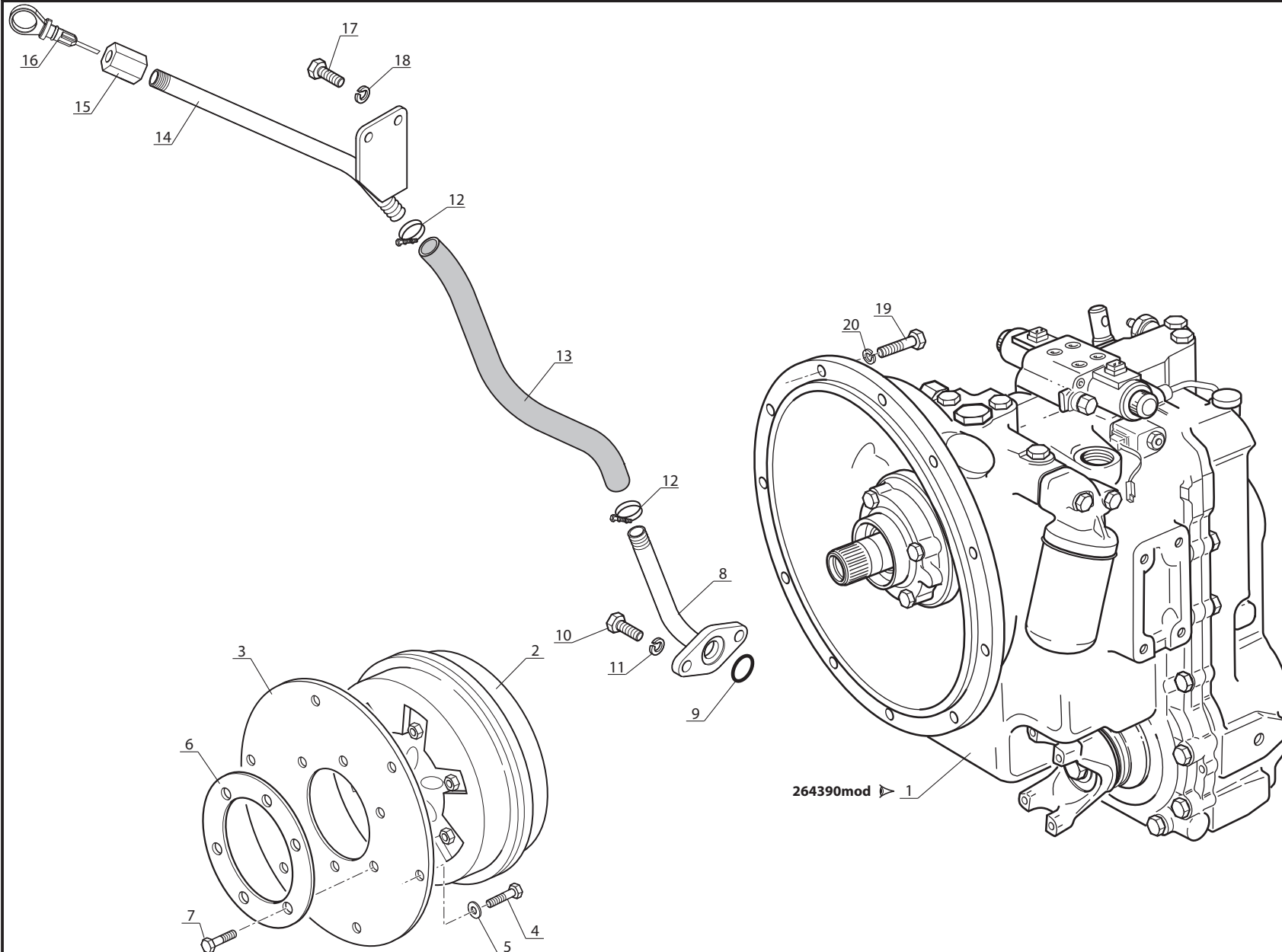

Catalogue : 647483

1	BOITE DE VITESSES ET CONVERTISSEUR GETRIEBEKASTEN UND UMFORMER CAJA DE VELOCIDADES Y CONVERTIDOR GEAR BOX AND CONVERTER CAMBIO E CONVERTITORE			Qte-Menge-Cant-Qty-Q.ta										BP 8066					M				
	Rep Hinw Fig Item Rif	Numéro Teil-Nr Numero Part-Nr Part-Nr	Désignation Bezeichnung Descripcion Description Descrizione	1	2	3	4	5	6	7	8	9	10	11	12	13	14	15		16	17	18	19
1	264390	Boîte de vitesse comp. Caja de velocidades completo Scàtola del cambio complete	- Kompletter getriebekasten - Complete gear box		1		1		1		1		1		1		1		1				
2	209372	Convertisseur Convertidor Convertitore	- Umformer - Converter		1		1		1		1		1		1		1		1				
3	209373	Plateau intermédiaire Placa intermediario Piatto intermedio	- Zwischenflansch - Intermediate piece		1		1		1		1		1		1		1		1				
4	209375	Vis H,5/16-16-UNC-REF.SF161 Tornillo Vite	- Schraube - Screw		6		6		6		6		6		6		6		6				
5	188544	Rondelle M8ZN 160HV Arandela Rondella	- Unterlegscheibe - Washer		6		6		6		6		6		6		6		6				
6	209374	Plateau de renfort Placa refuerzo Piatto di rinforzoä	- Umformer verstärkung platte - Converter reinforcement pl.		1		1		1		1		1		1		1		1				
7	209376	Vis H,3/8-13-UNF-REF.SF160 Tornillo Vite	- Schraube - Screw		6		6		6		6		6		6		6		6				
8	219432	Tubulure Tobera Tubo introduziore	- Leitung - Pipe		1		1		1		1		1		1		1		1				
9	4039	Joint torique Junta tórica Anello OR	- "0" ring - "0" ring		1		1		1		1		1		1		1		1				
10	44807	Vis H,M12-25-8.8-ZN8/C Tornillo Vite	- Schraube - Screw		2		2		2		2		2		2		2		2				
11	42231	RondelleW12ZN Arandela Rondella	- Unterlegscheibe - Washer		2		2		2		2		2		2		2		2				

+

Catalogue : 647483

2	BOITE DE VITESSES ET CONVERTISSEUR GETRIEBEKASTEN UND UMFORMER CAJA DE VELOCIDADES Y CONVERTIDOR GEAR BOX AND CONVERTER CAMBIO E CONVERTITORE			Qte-Menge-Cant-Qty-Q.ta										BP 8066									
	Rep Hinw Fig Item Rif	Número Teil-Nr Numero Part-Nr Part-Nr	Désignation Bezeichnung Descripcion Description Descrizione	1	2	3	4	5	6	7	8	9	10	11	12	13	14	15	16	17	18	19	20
12	71940	Collier Abrazadera Fascetta	- Spansschelle - Clamp		2		2		2		2		2		2		2		2				
13	251492	Durit (Lg 255) Tubo flexible Manicotto	- Schlauch - Hose		1		1		1		1		1		1		1		1				
14	251488	Tubulure Tobera Tubo introduttore	- Leitung - Pipe		1		1		1		1		1		1		1		1				
15	252997	Embout Tapón Ghiera	- Stopfen - Plug		1		1		1		1		1		1		1		1				
16	252947	Jauge (Lg703) Galga Livello	- Eichmass - Gauge		1		1		1		1		1		1		1		1				
17	63546	Vis H,M12-20-8.8-ZN8/C Tornillo Vite	- Schraube - Screw		2		2		2		2		2		2		2		2				
18	42231	Rondelle W12ZN Arandela Rondella	- Unterlegscheibe - Washer		2		2		2		2		2		2		2		2				
19	63545	Vis H,M10-35-8.8-ZN8/C Tornillo Vite	- Schraube - Screw		12		12		12		12		12		12		12		12				
20	42232	Rondelle W10 ZN Arandela Rondella	- Unterlegscheibe - Washer		12		12		12		12		12		12		12		12				

M

BP 268

POUR BOITE DE VITESSE
FÜR GETRIEBEKASTEN
PARA CAJA DE VELOCIDADES
FOR GEAR BOX
PER CAMBIO

Type: **16568**

Réf: **264 390**

BOITE DE VITESSES (Détails)
GETRIEBEKASTEN (Einzelteile)
CAJA DE VELOCIDADES (Detalles)
GEAR BOX (Details)
CAMBO (Dettaglio)

M 26-4 ST3B
M 30-4 ST3B
M 40-4 ST3B
M 50-4 ST3B

M 26-4H ST3B
M 30-4H ST3B
M 40-4H ST3B
M 50-4H ST3B



→ N°:
→ N°:

VOIR NOMENCLATURE *
SIEHE STÜCKLISTE *
VER NOMENCLATURA *
SEE NOMENCLATURE *
VEDERE NOMENCLATURA *

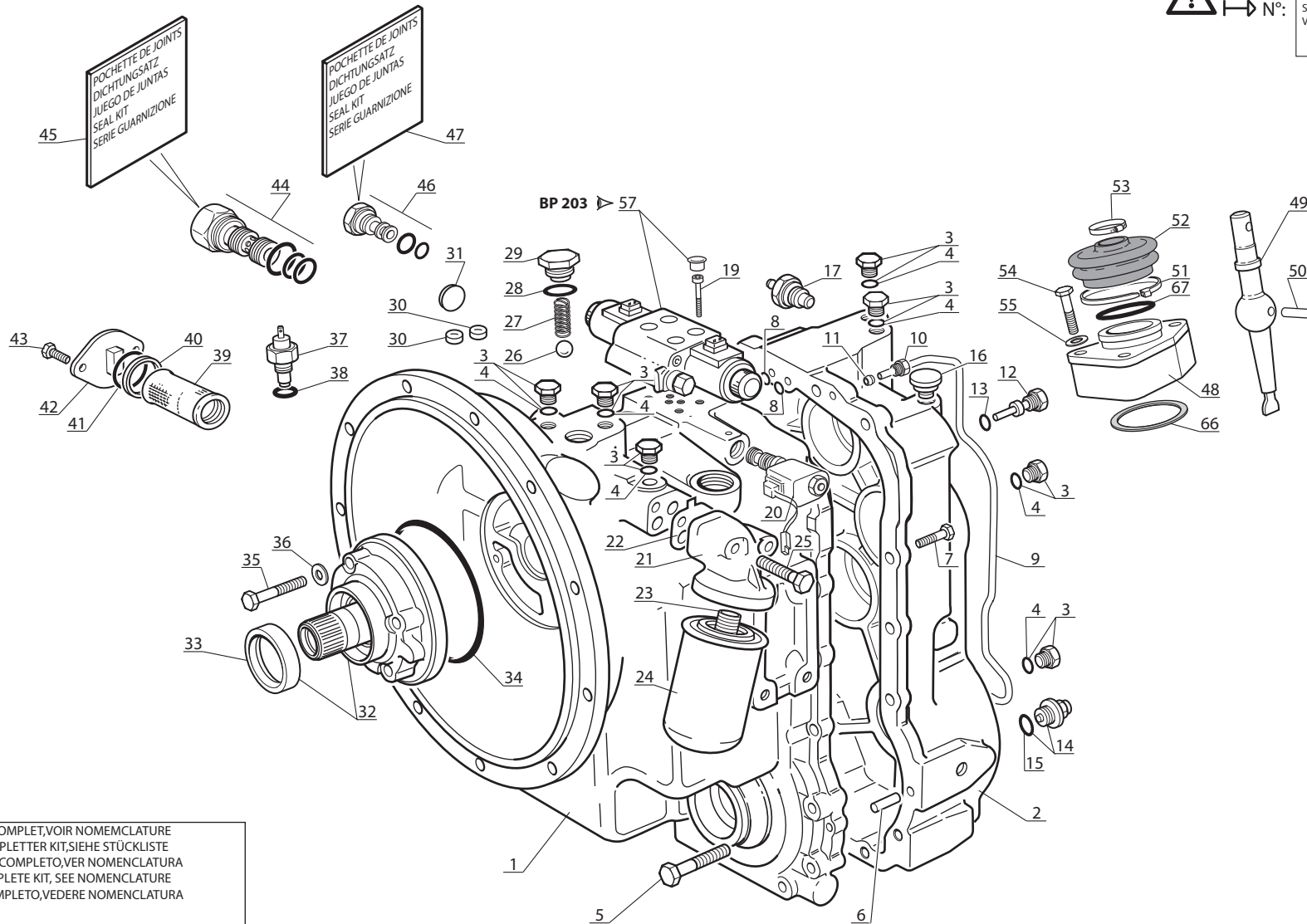

KIT COMPLET, VOIR NOMENCLATURE
KOMPLETTER KIT, SIEHE STÜCKLISTE
JUEGO COMPLETO, VER NOMENCLATURA
COMPLETE KIT, SEE NOMENCLATURE
KIT COMPLETO, VEDERE NOMENCLATURA

Rep - Hinw - Fig - Item - Sequenza
61 - 62 - 63

Catalogue : 264390MOD

Qté-Menge-Cant-Qty-Q.ta

BP

268

M

1

BOITE DE VITESSES (Détails)
 GETRIEBKASTEN (Einzelteile)
 CAJA DE VELOCIDADES (Detalles)
 GEAR BOX (Details)
 CAMBIO (Dettaglio)

1-	264390MOD	11-
2-		12-
3-		13-
4-		14-
5-		15-
6-		16-
7-		17-
8-		18-
9-		19-
10-		20-

Rep Hinw Fig Item Rif	Numéro Teil-Nr Numero Part-Nr Part-Nr	Désignation Bezeichnung Descripcion Description Descrizione	Qté-Menge-Cant-Qty-Q.ta																			
			1	2	3	4	5	6	7	8	9	10	11	12	13	14	15	16	17	18	19	20
1	561757	Carter transmission Carter transmisión Carter trasmissione - Transmission gehäuse - Transmission housing -	1																			
2	561758	Carter arrière transmission Carter trasero transmisión Carter posteriore trasmissione- - Transmission hinten kasten - Transmission rear case	1																			
3	550705	Bouchon Tapón Tappo - Stopfen - Plug -	11																			
4	109661	Bouchon Tapón Tappo - Stopfen - Plug -	11																			
5	561759	Vis Tornillo Vite - Schraube - Screw -	4																			
6	109703	Goujon Espárrago Prigioniero - Stiftschraube - Stud-bolt -	2																			
7	109727	Vis Tornillo Vite - Schraube - Screw -	13																			
8	561833	Joint torique Junta tórica Anello OR - "O" ring - "O" ring -	3																			
9	561825	Tubulure Tobera Tubo introduttore - Leitung - Pipe -	1																			
10	561824	Ecrou Tuerca Dado - Mutter - Nut -	2																			
11	561826	Olive Oliva Oliva - Schneidring - Olive -	2																			

+

Catalogue : 264390MOD

Qté-Menge-Cant-Qty-Q.ta

BP

268

M

2

BOITE DE VITESSES (Détails)
 GETRIEBKASTEN (Einzelteile)
 CAJA DE VELOCIDADES (Detalles)
 GEAR BOX (Details)
 CAMBIO (Dettaglio)

1-	264390MOD	11-
2-		12-
3-		13-
4-		14-
5-		15-
6-		16-
7-		17-
8-		18-
9-		19-
10-		20-

Rep Hinw Fig Item Rif	Numéro Teil-Nr Numero Part-Nr Part-Nr	Désignation Bezeichnung Descripcion Description Descrizione	Qté-Menge-Cant-Qty-Q.ta																			
			1	2	3	4	5	6	7	8	9	10	11	12	13	14	15	16	17	18	19	20
12	562823	Bouchon Tapón Tappo - Stopfen - Plug -	1																			
13	109657	Joint torique Junta tórica Anello OR - "0" ring - "0" ring -	1																			
14	473366	Bouchon de vidange Tapón de vaciado Tappo di scarico - Ablasschraube - Drain plug -	1																			
15	473915	Joint torique Junta tórica Anello OR - "0" ring - "0" ring -	1																			
16	109705	Reniflard Respiradero Sfiato - Entlüftung - Air breather -	1																			
17	705009	Mano-contact pression huile transmission Ol transmission druckschalter Mano contacto presión de aceite transmisión Transm oil pressure switch Interruttore pressione olio transmissione	1																			
19	561829	Vis Tornillo Vite - Schraube - Screw -	4																			
20	561831	Solénoïde Solenoid Solenoid - Solenoid - Solenoid -	1																			
21	561837	Carter filtre Carter filtro Carter filtro - Filter gehäuse - Filter housing -	1																			
22	109646	Joint plat Junta plana Guarnizióne - Dichtung - Gasket -	1																			
23	705954	Raccord Racor Raccordo - Verschraubung - Connection -	1																			

+

Catalogue : 264390MOD

Qté-Menge-Cant-Qty-Q.ta

BP

268

M

3

BOITE DE VITESSES (Détails)
 GETRIEBKASTEN (Einzelteile)
 CAJA DE VELOCIDADES (Detalles)
 GEAR BOX (Details)
 CAMBIO (Dettaglio)

1-	264390MOD	11-
2-		12-
3-		13-
4-		14-
5-		15-
6-		16-
7-		17-
8-		18-
9-		19-
10-		20-

Rep Hinw Fig Item Rif	Numéro Teil-Nr Numero Part-Nr Part-Nr	Désignation Bezeichnung Descripcion Description Descrizione	Qté-Menge-Cant-Qty-Q.ta																			
			1	2	3	4	5	6	7	8	9	10	11	12	13	14	15	16	17	18	19	20
24	561749	Filtre à huile transmission - Öl filter getriebe Filtro aceite transmisión - Oil filter transmission Filtro olio trasmissione -	1																			
25	748347	Vis - Schraube Tornillo - Screw Vite -	2																			
26	561836	Bille - Kugel Bola - Ball Sfera -	1																			
27	561765	Ressort - Feder Muelle - Spring Molla -	1																			
28	561827	Joint torique - "0" ring Junta tórica - "0" ring Anello OR -	1																			
29	561828	Bouchon - Stopfen Tapón - Plug Tappo -	1																			
30	561822	Bouchon - Stopfen Tapón - Plug Tappo -	2																			
31	561834	Bouchon d'expansion - Stopfen Tapón - Plug Tappo -	1																			
32	561930	Pompe complète - Kompletter Pumpe Bomba completa - Complete Pump Pompa completa -	1																			
33	109690	Joint d'étanchéité - Dichtungsring Junta de estanqueidad - Seal Guarnizióne -	1																			
34	109676	Joint torique - "0" ring Junta tórica - "0" ring Anello OR -	1																			

+

Catalogue : 264390MOD

Qté-Menge-Cant-Qty-Q.ta

BP

268

M

4

BOITE DE VITESSES (Détails)
 GETRIEBKASTEN (Einzelteile)
 CAJA DE VELOCIDADES (Detalles)
 GEAR BOX (Details)
 CAMBIO (Dettaglio)

1- 264390MOD 11-
 2- 12-
 3- 13-
 4- 14-
 5- 15-
 6- 16-
 7- 17-
 8- 18-
 9- 19-
 10- 20-

Rep Hinw Fig Item Rif	Numéro Teil-Nr Numero Part-Nr Part-Nr	Désignation Bezeichnung Descripcion Description Descrizione	Qté-Menge-Cant-Qty-Q.ta																			
			1	2	3	4	5	6	7	8	9	10	11	12	13	14	15	16	17	18	19	20
35	561760	Vis Tornillo Vite	- Schraube - Screw -	4																		
36	564381	Rondelle Arandela Rondella	- Unterlegscheibe - Washer -	4																		
37	702388	Sonde de température huile Sonda de temperatura de aceite Sonda temperatura olio	- Öl temperatur transmitter - Oil temperature sensor -	1																		
38	109657	Joint torique Junta tórica Anello OR	- "0" ring - "0" ring -	1																		
39	109565	Crépine d'aspiration Alcachofa de aspiración Pigna d'aspirazione	- Ansaugen seihe - Suction strainer -	1																		
40	550626	Rondelle Arandela Rondella	- Unterlegscheibe - Washer -	1																		
41	550627	Joint torique Junta tórica Anello OR	- "0" ring - "0" ring -	1																		
42	473368	Couvercle Tapadera Coperchio	- Deckel - Cover -	1																		
43	748351	Vis Tornillo Vite	- Schraube - Screw -	2																		
44	561830	Valve (Régulateur de pression) Válvula (Ajuste presión) Valvola (Regolatore)	- Ventil (Druckregulierung) - Valve (Pressure regulation) -	1																		
45	561946	Pochette de joints Juego de juntas Serie guarnizióne	- Dichtungssatz - Seal kit -	1																		

+

Catalogue : 264390MOD

Qté-Menge-Cant-Qty-Q.ta | BP 268 | M

5

BOITE DE VITESSES (Détails)
 GETRIEBKASTEN (Einzelteile)
 CAJA DE VELOCIDADES (Detalles)
 GEAR BOX (Details)
 CAMBIO (Dettaglio)

1-	264390MOD	11-
2-		12-
3-		13-
4-		14-
5-		15-
6-		16-
7-		17-
8-		18-
9-		19-
10-		20-

Rep Hinw Fig Item Rif	Numéro Teil-Nr Numero Part-Nr Part-Nr	Désignation Bezeichnung Descripcion Description Descrizione	Qté-Menge-Cant-Qty-Q.ta																			
			1	2	3	4	5	6	7	8	9	10	11	12	13	14	15	16	17	18	19	20
46	561823	Clapet de surpression - Druck ventil Válvula de superpresión - Over pressure valve Valvola di sovrappressione -	1																			
47	561945	Pochette de joints - Dichtungssatz Juego de juntas - Seal kit Serie guarnizióne -	1																			
48	562040	Siège supérieur - Ober Sitz Asiento superior - Upper seat Sedille superiore -	1																			
49	561816	Pied de levier de vitesses - Schalthebel fuss Pie de palanca de velocidades - Gear lever foot Braccio leva del cambio -	1																			
50	109681	Goupille - Stift Pasador - Pin Spina -	1																			
51	561820	Collier - Spannschelle Abrazadera - Clamp Fascetta -	1																			
52	109612	Cache poussière - Staubschützer Guardapolvo - Dust cover Coperchio raschiapolvere -	1																			
53	561821	Collier - Spannschelle Abrazadera - Clamp Fascetta -	1																			
54	561760	Vis - Schraube Tornillo - Screw Vite -	3																			
55	561761	Rondelle - Unterlegscheibe Arandela - Washer Rondella -	3																			
57	702639	Valve de contrôle électrique - Elektrische kontrollventil Válvula de control electrico - Electrical control valve Valvola di controllo elettrico-	1																			

+

Catalogue : 264390MOD

6

BOITE DE VITESSES (Détails)
 GETRIEBKASTEN (Einzelteile)
 CAJA DE VELOCIDADES (Detalles)
 GEAR BOX (Details)
 CAMBIO (Dettaglio)

Qté-Menge-Cant-Qty-Q.ta

BP

268

M

1-	264390MOD	11-
2-		12-
3-		13-
4-		14-
5-		15-
6-		16-
7-		17-
8-		18-
9-		19-
10-		20-

Rep Hinw Fig Item Rif	Numéro Teil-Nr Numero Part-Nr Part-Nr	Désignation Bezeichnung Descripcion Description Descrizione	Qté-Menge-Cant-Qty-Q.ta																			
			1	2	3	4	5	6	7	8	9	10	11	12	13	14	15	16	17	18	19	20
61	561934	Kit petites pièces Juego pequeñas piezas Kit piccoli pezzi	- Einzelteile satz - Small parts kit -	X																		
62	562002	Pochette de joints Juego de juntas Serie guarnizióne	- Dichtungssatz - Seal kit -	X																		
63	562003	Pochette de joints Juego de juntas Serie guarnizióne	- Dichtungssatz - Seal kit -	X																		
66	600366	Joint torique Junta tórica Anello OR	- "0" ring - "0" ring -	1																		
67	600365	Joint plat Junta plana Guarnizióne * M26-4 Série 3 M30-4 Série 3 M40-4 Série 3 M50-4 Série 3 A PARTIR DE LA MACHINE 253873 AB DER MASCHINE 253873 A PARTIR DE LA MAQUINA 253873 FROM MACHINE 253873 A PARTIR DA MACCHINA 253873 * Composition des Kits Kitzusammensetzung Composición de los conjuntos Kits composition Composizione kit - 561934 = Rep,Hinw,Fig,Item 3,26,27,50,51,52,53 (BP268) + 73,74,75 (BP269) - 562002 = Rep,Hinw,Fig,Item 49,64,76,100 (BP269) + 4,8,15,28,41 (BP268) - 562003 = Rep,Hinw,Fig,Item 30,31,33,34,36 (BP268) + 6,40,47,65 (BP269)	- Dichtung - Gasket -	1																		

BP 269

POUR BOITE DE VITESSES PER CAMBIO
FÜR GETRIEBEKASTEN
PARA CAJA DE VELOCIDADES
FOR GEAR BOX

Type: **16568**
Réf: **264 390**

BOITE DE VITESSES (Détails
mécanismes - Pignonnerie)
GETRIEBEKASTEN (Mechanismus
einzelteile - Zahnrad)
CAJA DE VELOCIDADES (Detalles
mecanismo - Pinón)

GEAR BOX (Mechanism details - Gear)
CAMBIO (Particolari Meccanici - Pignone)

M 26-4 ST3B M 26-4H ST3B
M 30-4 ST3B M 30-4H ST3B
M 40-4 ST3B M 40-4H ST3B
M 50-4 ST3B M 50-4H ST3B

KIT COMPLET, VOIR NOMENCLATURE
KOMPLETTER KIT, SIEHE STÜCKLISTE
JUEGO COMPLETO, VER NOMENCLATURA
COMPLETE KIT, SEE NOMENCLATURE
KIT COMPLETO, VEDERE NOMENCLATURA

Rep - Hinw - Fig - Item - Sequenza
90 - 91 - 92 - 93 - 94 - 95 - 96
97 - 98 - 103 - 104



→ N°:
→ N°:

VOIR NOMENCLATURE *
SIEHE STÜCKLISTE *
VER NOMENCLATURA *
SEE NOMENCLATURE *
VEDERE NOMENCLATURA *

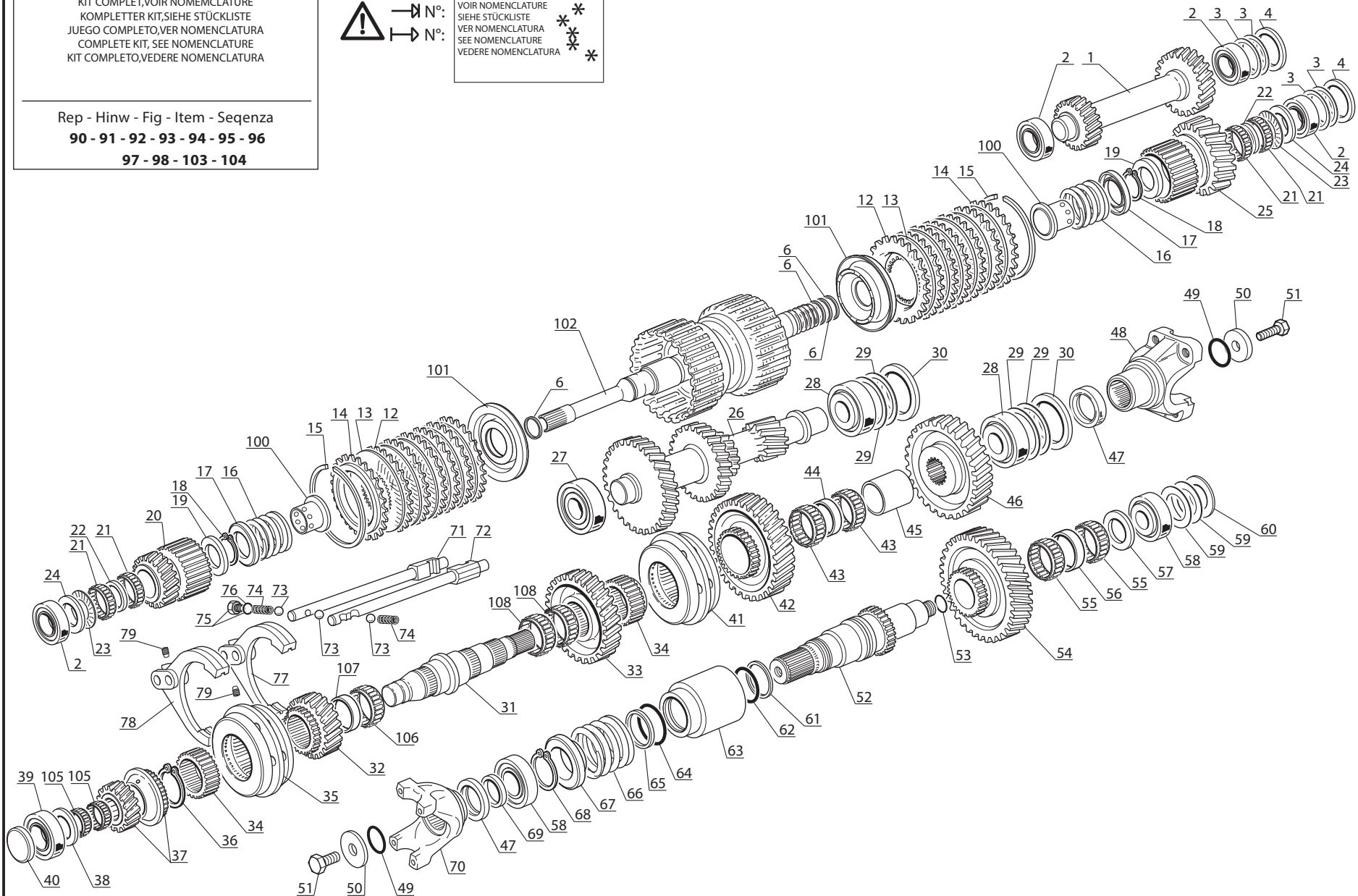

Catalogue : 264390MOD

Qté-Menge-Cant-Qty-Q.ta

BP

269

M

1

BOITE DE VITESSES (Détails mécanismes - Pignonnerie)
 GETRIEBKASTEN (Mechanismus einzelteile - Zahnrad)
 CAJA DE VELOCIDADES (Detalles mecanismo - Piñón)
 GEAR BOX (Mechanism details - Gear)
 CAMBIO (Particolari meccanici - Pignone)

1-	264390MOD	11-
2-		12-
3-		13-
4-		14-
5-		15-
6-		16-
7-		17-
8-		18-
9-		19-
10-		20-

Rep Hinw Fig Item Rif	Numéro Teil-Nr Numero Part-Nr Part-Nr	Désignation Bezeichnung Descripcion Description Descrizione																				
			1	2	3	4	5	6	7	8	9	10	11	12	13	14	15	16	17	18	19	20
1	561791	Pignon d'inverseur Piñón de inversor Ingranaggio di invertitore	- Umstellzahnrad - Reverse idler gear -	1																		
2	109701	Roulement Rodamiento Cuscinetto	- Lager - Bearing -	4																		
3	109615	Cale d'épaisseur 0,051 mm Cala de espesor Spessore	- Ausgleichscheibe - Shim -	4																		
3	109616	Cale d'épaisseur 0,076 mm Cala de espesor Spessore	- Ausgleichscheibe - Shim -	X																		
3	109617	Cale d'épaisseur 0,127 mm Cala de espesor Spessore	- Ausgleichscheibe - Shim -	X																		
3	109618	Cale d'épaisseur 0,178 mm Cala de espesor Spessore	- Ausgleichscheibe - Shim -	X																		
3	109619	Cale d'épaisseur 0,381 mm Cala de espesor Spessore	- Ausgleichscheibe - Shim -	X																		
3	109620	Cale d'épaisseur 0,508 mm Cala de espesor Spessore	- Ausgleichscheibe - Shim -	X																		
4	109597	Entretoise Separador Distanziale	- Querstrebe - Spacer -	2																		
6	109624	Joint d'étanchéité Junta de estanqueidad Guarnizione	- Dichtungsring - Seal -	4																		
12	561797	Disque d'embrayage Disco de embrague Disco d'innesto	- Kupplung disk - Clutch disc -	12																		

+

Catalogue : 264390MOD

Qté-Menge-Cant-Qty-Q.ta

BP

269

M

2

BOITE DE VITESSES (Détails mécanismes - Pignonnerie)
 GETRIEBKASTEN (Mechanismus einzelteile - Zahnrad)
 CAJA DE VELOCIDADES (Detalles mecanismo - Piñón)
 GEAR BOX (Mechanism details - Gear)
 CAMBIO (Particolari meccanici - Pignone)

1-	264390MOD	11-
2-		12-
3-		13-
4-		14-
5-		15-
6-		16-
7-		17-
8-		18-
9-		19-
10-		20-

Rep Hinw Fig Item Rif	Numéro Teil-Nr Numero Part-Nr Part-Nr	Désignation Bezeichnung Descripcion Description Descrizione																					
			1	2	3	4	5	6	7	8	9	10	11	12	13	14	15	16	17	18	19	20	
13	561798	Disque de friction Disco de fricción Disco frizione	-	Reibung disk																			12
14	561796	Plateau Placa Piatto	-	Platte																			2
15	561795	Circlips Aro retén Anello elastico	-	Sicherungsring																			2
16	561801	Ressort Muelle Molla	-	Feder																			2
17	561800	Bague Anillo Anello	-	Büchse																			2
18	561799	Circlips Aro retén Anello elastico	-	Sicherungsring																			2
19	561789	Rondelle de poussée Arandela de presión Rondella	-	Druck unterlegscheibe																			2
20	561793	Pignon primaire marche avant Piñón primario marcha adelante Ingranaggio primario marcia avanti	-	Vorwärtsgang primär zahnrad																			1
21	109651	Roulement à aiguilles Rodamiento de agujas Cuscinetto	-	Rollenlager																			4
22	561809	Entretoise Separador Distanziale	-	Querstrebe																			2
23	561762	Roulement Rodamiento Cuscinetto	-	Läger																			2

+

Catalogue : 264390MOD

Qté-Menge-Cant-Qty-Q.ta

BP

269

M

3

BOITE DE VITESSES (Détails mécanismes - Pignonnerie)
 GETRIEBKASTEN (Mechanismus einzelteile - Zahnrad)
 CAJA DE VELOCIDADES (Detalles mecanismo - Piñón)
 GEAR BOX (Mechanism details - Gear)
 CAMBIO (Particolari meccanici - Pignone)

1-	264390MOD	11-
2-		12-
3-		13-
4-		14-
5-		15-
6-		16-
7-		17-
8-		18-
9-		19-
10-		20-

Rep Hinw Fig Item Rif	Numéro Teil-Nr Numero Part-Nr Part-Nr	Désignation Bezeichnung Descripcion Description Descrizione																				
			1	2	3	4	5	6	7	8	9	10	11	12	13	14	15	16	17	18	19	20
24	561764	Rondelle de butée - Anschlagunterlegscheibe Arandela de tope - Stop washer Rondella reggisp -	2																			
25	561794	Pignon primaire marche arrière (27 dents) Rückwärtsgang primär Zahnrad Piñón primario marcha atrás - Backward primary gear Pignone primario retro-marcia -	1																			
26	561790	Arbre de renvoi - Vorgelegewelle Arbo de reenvio - Countershaft Albero di rinvio -	1																			
27	109622	Roulement - Lager Rodamiento - Bearing Cuscinetto -	1																			
28	561786	Roulement - Lager Rodamiento - Bearing Cuscinetto -	2																			
29	109599	Cale d'épaisseur 0,051 mm - Ausgleichscheibe Cala de espesor - Shim Spessore -	X																			
29	109600	Cale d'épaisseur 0,076 mm - Ausgleichscheibe Cala de espesor - Shim Spessore -	X																			
29	109601	Cale d'épaisseur 0,178 mm - Ausgleichscheibe Cala de espesor - Shim Spessore -	X																			
29	109602	Cale d'épaisseur 0,559 mm - Ausgleichscheibe Cala de espesor - Shim Spessore -	X																			
30	109598	Entretoise - Querstrebe Separador - Spacer Distanziale -	2																			
31	746716	Arbre de sortie - Ausgangs welle Arbol de salida - Out put shaft Albero di uscita -	1																			

+

Catalogue : 264390MOD

Qté-Menge-Cant-Qty-Q.ta | BP 269 | M

4

BOITE DE VITESSES (Détails mécanismes - Pignonnerie)
 GETRIEBKASTEN (Mechanismus einzelteile - Zahnrad)
 CAJA DE VELOCIDADES (Detalles mecanismo - Piñón)
 GEAR BOX (Mechanism details - Gear)
 CAMBIO (Particolari meccanici - Pignone)

1-	264390MOD	11-
2-		12-
3-		13-
4-		14-
5-		15-
6-		16-
7-		17-
8-		18-
9-		19-
10-		20-

Rep Hinw Fig Item Rif	Numéro Teil-Nr Numero Part-Nr Part-Nr	Désignation Bezeichnung Descripcion Description Descrizione	Qté-Menge-Cant-Qty-Q.ta																			
			1	2	3	4	5	6	7	8	9	10	11	12	13	14	15	16	17	18	19	20
32	748349	Pignon 3ème vitesse Piñón 3ra velocidad Ingranaggio 3° marcia	-	Zahnrad 3ten gang - 3rd gear -	1																	
33	748350	Pignon 2ème vitesse Piñón 2da velocidad Ingranaggio 2° marcia	-	Zahnrad 2te gang - 2nd gear -	1																	
34	109586	Manchon cannelé Manguito acanalado Manicotto	-	Kupplungsmuffe - Coupling sleeve -	2																	
35	109665	Ensemble synchro Conjunto sincrón Insieme sincronizzazione	-	Kompletter Drehmelder - Synchro assy -	1																	
36	109664	Circlips Aro retén Anello elastico	-	Sicherungsring - Circlip -	1																	
37	748348	Pignon 4ème vitesse Piñón 4ta velocidad Ingranaggio 4° marcia	-	Zahnrad 4ten gang - 4th gear -	1																	
38	561784	Rondelle Arandela Rondella	-	Unterlegscheibe - Washer -	1																	
39	561788	Roulement Rodamiento Cuscinetto	-	Läger - Bearing -	1																	
40	550632	Bouchon Tapón Tappo	-	Stopfen - Plug -	1																	
41	109665	Ensemble synchro Conjunto sincrón Insieme sincronizzazione	-	Kompletter Drehmelder - Synchro assy -	1																	
42	109568	Pignon 1ère vitesse (43 dents) Piñón 1ra velocidad Ingranaggio 1° marcia	-	Zahnrad 1ten gang - Out put shaft 1st gear -	1																	



Catalogue : 264390MOD

Qté-Menge-Cant-Qty-Q.ta | **BP** | **269** | **M**

5

BOITE DE VITESSES (Détails mécanismes - Pignonnerie)
 GETRIEBKASTEN (Mechanismus einzelteile - Zahnrad)
 CAJA DE VELOCIDADES (Detalles mecanismo - Piñón)
 GEAR BOX (Mechanism details - Gear)
 CAMBIO (Particolari meccanici - Pignone)

1-	264390MOD	11-
2-		12-
3-		13-
4-		14-
5-		15-
6-		16-
7-		17-
8-		18-
9-		19-
10-		20-

Rep Hinw Fig Item Rif	Numéro Teil-Nr Numero Part-Nr Part-Nr	Désignation Bezeichnung Descripcion Description Descrizione																				
			1	2	3	4	5	6	7	8	9	10	11	12	13	14	15	16	17	18	19	20
43	109621	Roulement - Läger Rodamiento - Bearing Cuscinetto -	2																			
44	109653	Entretoise - Querstrebe Separador - Spacer Distanziale -	1																			
45	109652	Manchon - Muffe Manguito - Coupling Manicotto -	1																			
46	561777	Pignon d'entraînement arbre de sortie (37 dents) Auslaufwelle antrieb zahnrad Piñon de arrastre árbol de salida Out put shaft drive gear Ingranaggio alimentazione del albero di uscita	1																			
47	781700	Joint d'étanchéité - Dichtring Junta de estanqueidad - Seal Guarnizione di tenuta -	2																			
48	561807	Chape d'accouplement - Gabelkupplung Horquilla de acoplamiento - End yoke Forcella -	1																			
49	550636	Joint torique - "0" ring Junta tórica - "0" ring Anello OR -	2																			
50	109798	Rondelle - Unterlegscheibe Arandela - Washer Rondella -	2																			
51	561810	Vis - Schraube Tornillo - Screw Vite -	2																			
52	561771	Arbre de sortie - Ausgangs welle Arbol de salida - Out put shaft Albero di uscita -	1																			
53	561778	Joint torique - "0" ring Junta tórica - "0" ring Anello OR -	1																			

+

Catalogue : 264390MOD

Qté-Menge-Cant-Qty-Q.ta

BP

269

M

6

BOITE DE VITESSES (Détails mécanismes - Pignonnerie)
 GETRIEBKASTEN (Mechanismus einzelteile - Zahnrad)
 CAJA DE VELOCIDADES (Detalles mecanismo - Piñón)
 GEAR BOX (Mechanism details - Gear)
 CAMBIO (Particolari meccanici - Pignone)

1-	264390MOD	11-
2-		12-
3-		13-
4-		14-
5-		15-
6-		16-
7-		17-
8-		18-
9-		19-
10-		20-

Rep Hinw Fig Item Rif	Numéro Teil-Nr Numero Part-Nr Part-Nr	Désignation Bezeichnung Descripcion Description Descrizione	Qté-Menge-Cant-Qty-Q.ta																																										
			1	2	3	4	5	6	7	8	9	10	11	12	13	14	15	16	17	18	19	20																							
54	561772	Pignon (37 dents) Piñón (37 dientes) Ingranaggio (37 dente)	-																					- Zahnrad (37 zähne) - Gear (37 teeth) -	1																				
55	561838	Roulement à aiguilles Rodamiento de agujas Cuscinetto	-																					- Rollenlager - Roller bearing -	2																				
56	561839	Entretoise Separador Distanziale	-																					- Querstrebe - Spacer -	1																				
57	561773	Rondelle Arandela Rondella	-																					- Unterlegscheibe - Washer -	1																				
58	561787	Roulement Rodamiento Cuscinetto	-																					- Lager - Bearing -	2																				
59	561780	Cale d'épaisseur 0,051 mm Cala de espesor Spessore	-																					- Ausgleichscheibe - Shim -	X																				
59	561781	Cale d'épaisseur 0,076 mm Cala de espesor Spessore	-																					- Ausgleichscheibe - Shim -	X																				
59	561782	Cale d'épaisseur 0,178 mm Cala de espesor Spessore	-																					- Ausgleichscheibe - Shim -	X																				
59	561783	Cale d'épaisseur 0,599 mm Cala de espesor Spessore	-																					- Ausgleichscheibe - Shim -	X																				
60	561779	Entretoise Separador Distanziale	-																					- Querstrebe - Spacer -	1																				
61	561763	Joint d'étanchéité Junta de estanqueidad Guarnizióne	-																					- Dichtungsring - Seal -	1																				

+

Catalogue : 264390MOD

Qté-Menge-Cant-Qty-Q.ta | BP 269 | M

7

BOITE DE VITESSES (Détails mécanismes - Pignonnerie)
 GETRIEBKASTEN (Mechanismus einzelteile - Zahnrad)
 CAJA DE VELOCIDADES (Detalles mecanismo - Piñón)
 GEAR BOX (Mechanism details - Gear)
 CAMBIO (Particolari meccanici - Pignone)

1-	264390MOD	11-
2-		12-
3-		13-
4-		14-
5-		15-
6-		16-
7-		17-
8-		18-
9-		19-
10-		20-

Rep Hinw Fig Item Rif	Número Teil-Nr Numero Part-Nr Part-Nr	Désignation Bezeichnung Descripcion Description Descrizione	Qté-Menge-Cant-Qty-Q.ta																			
			1	2	3	4	5	6	7	8	9	10	11	12	13	14	15	16	17	18	19	20
62	561766	Joint torique Junta tórica Anello OR	- "0" ring - "0" ring -	1																		
63	561768	Manchon Manguito Manicotto	- Muffe - Coupling -	1																		
64	561818	Joint torique Junta tórica Anello OR	- "0" ring - "0" ring -	1																		
65	561819	Joint d'étanchéité Junta de estanqueidad Guarnizione	- Dichtungsring - Seal -	1																		
66	561769	Ressort Muelle Molla	- Feder - Spring -	1																		
67	561770	Support ressort Soporte Muelle Supporto molla	- Feder Träger - Spring bracket -	1																		
68	561767	Circlips Aro retén Anello elastico	- Sicherungsring - Circlip -	1																		
69	561808	Entretoise Separador Distanziale	- Querstrebe - Spacer -	1																		
70	561807	Chape d'accouplement Horquilla de acoplamiento Forcella	- Gabelkupplung - End yoke -	1																		
71	561814	Coulisseau de 1ère et 2ème Riel cambio velocidades 1ra y 2ra 1st and 2nd shift rod Guida 1 e 2	- Führung 1ten und 2ten - -	1																		
72	561815	Coulisseau de 3ème et 4ème Riel cambio velocidades 3ra y 4ra 3rd and 4th shift rod Guida 3 e 4	- Führung 3ten und 4ten - -	1																		

+

Catalogue : 264390MOD

Qté-Menge-Cant-Qty-Q.ta | **BP** | **269** | **M**

8

BOITE DE VITESSES (Détails mécanismes - Pignonnerie)
 GETRIEBKASTEN (Mechanismus einzelteile - Zahnrad)
 CAJA DE VELOCIDADES (Detalles mecanismo - Piñón)
 GEAR BOX (Mechanism details - Gear)
 CAMBIO (Particolari meccanici - Pignone)

1-	264390MOD	11-
2-		12-
3-		13-
4-		14-
5-		15-
6-		16-
7-		17-
8-		18-
9-		19-
10-		20-

Rep Hinw Fig Item Rif	Número Teil-Nr Numero Part-Nr Part-Nr	Désignation Bezeichnung Descripcion Description Descrizione	Qté-Menge-Cant-Qty-Q.ta																			
			1	2	3	4	5	6	7	8	9	10	11	12	13	14	15	16	17	18	19	20
73	109709	Bille Bola Sfera - Kugel - Ball -	3																			
74	473920	Ressort Muelle Molla - Feder - Spring -	2																			
75	550705	Bouchon Tapón Tappo - Stopfen - Plug -	1																			
76	109657	Joint torique Junta tórica Anello OR - "0" ring - "0" ring -	1																			
77	561812	Fourchette 1ère et 2ème Horquilla 1ra y 2da Forcella 1 e 2 - Gabel 1ten und 2ten - 1st and 2nd shift fork -	1																			
78	561813	Fourchette 3ème et 4ème Horquilla 3ra y 4ra Forcella 3 e 4 - Gabel 3ten und 4ten - 3rd and 4th shift fork -	1																			
79	109737	Vis Tornillo Vite - Schraube - Screw -	2																			
90	705892	Kit embrayage Juego de embrague Kit innesto - Kupplungsatz - Clutch pack kit -	X																			
91	703472	Kit embrayage complet Juego de embrague completo Kit innesto completo - Kompletter Kupplungsatz - Complete clutch pack kit -	X																			
92	561934	Kit petites pièces Juego pequeñas piezas Kit piccoli pezzi - Einzelteile satz - Small parts kit -	X																			
93	562001	Jeu de roulement Juego cojinete Kit cuscinetto - Lagersatz - Bearing kit -	X																			

+

Catalogue : 264390MOD

Qté-Menge-Cant-Qty-Q.ta

BP

269

M

9

BOITE DE VITESSES (Détails mécanismes - Pignonnerie)
 GETRIEBKASTEN (Mechanismus einzelteile - Zahnrad)
 CAJA DE VELOCIDADES (Detalles mecanismo - Piñón)
 GEAR BOX (Mechanism details - Gear)
 CAMBIO (Particolari meccanici - Pignone)

1-	264390MOD	11-
2-		12-
3-		13-
4-		14-
5-		15-
6-		16-
7-		17-
8-		18-
9-		19-
10-		20-

Rep Hinw Fig Item Rif	Numéro Teil-Nr Numero Part-Nr Part-Nr	Désignation Bezeichnung Descripcion Description Descrizione	Qté-Menge-Cant-Qty-Q.ta																			
			1	2	3	4	5	6	7	8	9	10	11	12	13	14	15	16	17	18	19	20
94	562002	Pochette de joints Juego de juntas Serie guarnizióne	- Dichtungssatz - Seal kit -	X																		
95	562003	Pochette de joints Juego de juntas Serie guarnizióne	- Dichtungssatz - Seal kit -	X																		
96	562004	Jeu de circlips Juego de aro retén Kit anello elastico	- Sicherungsring satz - Circlip kit -	X																		
97	562005	Jeu de rondelles Juego de arandelas Kit rondella	- Unterlagscheibensatz - Washer kit -	X																		
98	561940	Jeu de rondelles de poussée Juego de arandela de presión Kit rondella	- Druckscheibe satz - Thrust washer kit -	X																		
100	602730	Bague Anillo Anello	- Büchse - Bushing -	2																		
101	702819	Kit piston Kit pistón Kit pistone	- Kolben kit - Piston kit -	2																		
102	602729	Arbre d'entrée Arbol de entrada Albero di entrato	- Antriebswelle - Input shaft -	1																		
103	705892	Kit embrayage Juego de embrague Kit innesto	- Kupplungsatz - Clutch pack kit -	X																		
104	703472	Kit embrayage complet Juego de embrague completo Kit innesto completo	- Kompletter Kupplungsatz - Complete clutch pack kit -	X																		
105	109651	Roulement à aiguilles Rodamiento de agujas Cuscinetto	- Rollenlager - Roller bearing -	2																		

+

Catalogue : 264390MOD

BOITE DE VITESSES (Détails mécanismes - Pignonnerie)
 GETRIEBKASTEN (Mechanismus einzelteile - Zahnrad)
 CAJA DE VELOCIDADES (Detalles mecanismo - Piñón)
 GEAR BOX (Mechanism details - Gear)
 CAMBIO (Particolari meccanici - Pignone)

Qté-Menge-Cant-Qty-Q.ta

BP

269

M

10

1-	264390MOD	11-
2-		12-
3-		13-
4-		14-
5-		15-
6-		16-
7-		17-
8-		18-
9-		19-
10-		20-

Rep Hinw Fig Item Rif	Numéro Teil-Nr Numero Part-Nr Part-Nr	Désignation Bezeichnung Descripcion Description Descrizione
-----------------------------------	---	---

1	2	3	4	5	6	7	8	9	10	11	12	13	14	15	16	17	18	19	20
---	---	---	---	---	---	---	---	---	----	----	----	----	----	----	----	----	----	----	----

106	564454	Roulement à aiguilles Rodamiento de agujas Cuscinetto - Rollenlager - Roller bearing -
107	746717	Rondelle Arandela Rondella - Unterlegscheibe - Washer -
108	109621	Roulement Rodamiento Cuscinetto - Läger - Bearing - * M26-4 Série 3 M30-4 Série 3 M40-4 Série 3 M50-4 Série 3 A PARTIR DE LA MACHINE 253873 AB DER MASCHINE 253873 A PARTIR DE LA MAQUINA 253873 FROM MACHINE 253873 A PARTIR DA MACCHINA 253873 * Composition des Kits Kitzusammensetzung Composición de los conjuntos Kits composition Composizione kit - 705892 = Rep,Hinw, Fig, Item 12,13,14,15,16,17,18,100,101 - 703472 = Rep,Hinw, Fig, Item 102 (BP269) + Kit 103 - 561934 = Rep,Hinw, Fig, Item 3,26,27,50,51,52,53 (BP268) + 73,74,75 (BP269) - 561940 = Rep,Hinw, Fig, Item 19,24,38 - 562001 = Rep,Hinw, Fig, Item 2,21,23,27,28,39,43,45,58 - 562002 = Rep,Hinw, Fig, Item 49,64,76,100 (BP269) + 4,8,15,28,41 (BP268) - 562003 = Rep,Hinw, Fig, Item 30,31,33,34,36 (BP268) + 6,40,47,65 (BP269)

1																				
1																				
2																				

+

Catalogue : 264390MOD

11

BOITE DE VITESSES (Détails mécanismes - Pignonnerie)
 GETRIEBKASTEN (Mechanismus einzelteile - Zahnrad)
 CAJA DE VELOCIDADES (Detalles mecanismo - Piñón)
 GEAR BOX (Mechanism details - Gear)
 CAMBIO (Particolari meccanici - Pignone)

Qté-Menge-Cant-Qty-Q.ta

BP

269

M

1-	264390MOD	11-
2-		12-
3-		13-
4-		14-
5-		15-
6-		16-
7-		17-
8-		18-
9-		19-
10-		20-

Rep Hinw Fig Item Rif	Numéro Teil-Nr Numero Part-Nr Part-Nr	Désignation Bezeichnung Descripcion Description Descrizione
		- 562004 = Rep,Hinw,Fig,Item 15,18,36 - 562005 = Rep,Hinw,Fig,Item 3,29

1	2	3	4	5	6	7	8	9	10	11	12	13	14	15	16	17	18	19	20	

BP 203

VALVE DE CONTROLE ELECTRIQUE
 ELEKTRISCHE KONTROLLVENTIL
 VALVULA DE CONTROL ELECTRICA
 ELECTRICAL CONTROL VALVE
 VAVOLA DI CONTROLLO ELLETTRICO

M 26-4 ST3B **M 26-4H ST3B**
M 30-4 ST3B **M 30-4H ST3B**
M 40-4 ST3B **M 40-4H ST3B**
M 50-4 ST3B **M 50-4H ST3B**

POUR BOITE DE VITESSE
 FÜR GETREIBEKASTEN
 PARA CAJA DE VELOCIDADES
 FOR GEAR BOX
 PER CAMBIO

A PARTIR DE LA BOITE DE VITESSE
 AB DER GETREIBEKASTEN
 A PARTIR DE LA CAJA DE VELOCIDADES
 FROM GEAR BOX
 A PARTIR DEL CAMBIO



→ N°:
 ↳ N°:

VOIR NOMENCLATURE
 SIEHE STÜCKLISTE
 VER NOMENCLATURA
 SEE NOMENCLATURA
 VEDERE NOMENCLATURA



NON LIVRE AVEC REP. 1
 NICHT GELIEFERT MIT HINW. 1
 NO ENTREGADOS CON FIG. 1
 NOT DELIVERED WITH ITEM. 1
 NO CONSEGNARE CON SEQU. 1

■ KIT COMPLET, VOIR NOMENCLATURE
 KOMPLETTER KIT, SIEHE STÜCKLISTE
 JUEGO COMPLETO, VER NOMENCLATURA
 COMPLETE KIT, SEE NOMENCLATURA
 KIT COMPLETO, VEDERE NOMENCLATURA

Rep - Hinw - Fig - Item - Sequenza
8

- Type: **15984** Réf: **222 572**
- Type: **15985** Réf: **222 573**
- Type: **16025** Réf: **226 228**
- Type: **16024** Réf: **226 229**
- Type: **16097** Réf: **232 444**
- Type: **16335** Réf: **247 596**
- Type: **16486** Réf: **258 799**
- Type: **16486** Réf: **258 800**
- Type: **16564** Réf: **264 389**
- Type: **16568** Réf: **264 390**
- Type: **16566** Réf: **264 391**

- ↳ N°: **G03 - 2639**
- ↳ N°: **G03 - 2208**
- ↳ N°: **G03 - 14975**
- ↳ N°: **G03 - 10170**
- ↳ N°: **G03 - 1253**

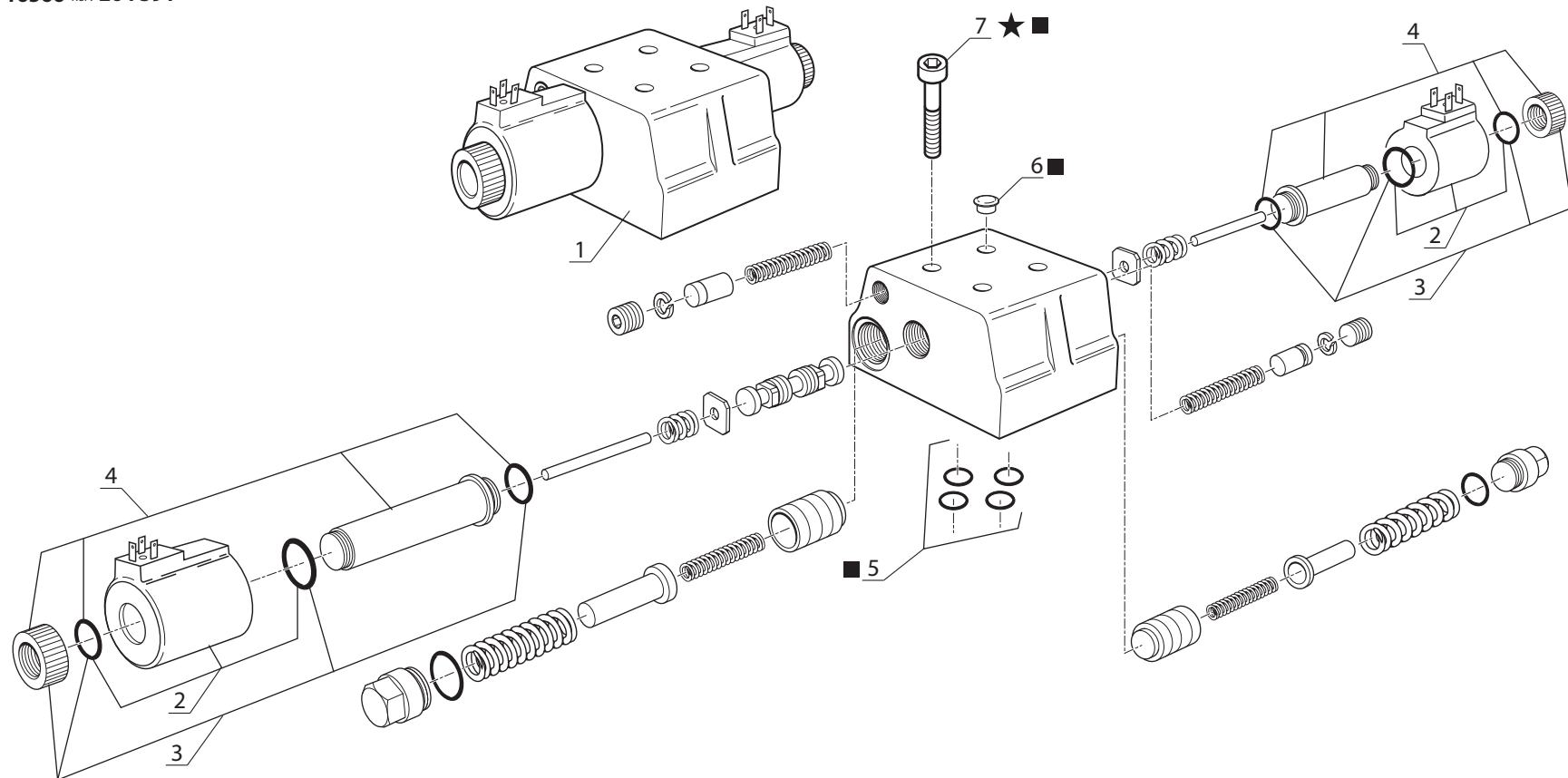

Catalogue : 264389MOD

Qté-Menge-Cant-Qty-Q.ta

BP

203

M

1

VALVE DE CONTROLE ELECTRIQUE
ELEKTRISCHE KONTROLLVENTIL
VALVULA DE CONTROL ELECTRICO
ELECTRICAL CONTROL VALVE
VALVOLA DI CONTROLLO ELLETTRICO

1- 264389MOD 11-
2- 12-
3- 13-
4- 14-
5- 15-
6- 16-
7- 17-
8- 18-
9- 19-
10- 20-

Rep Hinw Fig Item Rif	Numéro Teil-Nr Numero Part-Nr Part-Nr	Désignation Bezeichnung Descripcion Description Descrizione	Qté-Menge-Cant-Qty-Q.ta																			
			1	2	3	4	5	6	7	8	9	10	11	12	13	14	15	16	17	18	19	20
1	702639	Valve de contrôle électrique - Elektrische kontrollventil Válvula de control electrico - Electrical control valve Valvola di controllo elettrico-	1																			
2	702381	Solénoïde - Solenoid Solenoid - Solenoid Solenoid -	2																			
3	702382	Kit petites pièces - Einzelteile satz Juego pequeña piezas - Small parts kit Kit piccoli pezzi -	2																			
4	702383	Support solénoïde - Solenoid tr�ager Soporte solenoide - Solenoid bracket Supporto solenoide -	2																			
5	561943	Pochette de joints - Dichtungssatz Juego de juntas - Seal kit Serie guarnizi�one -	1																			
6	562043	Bouchon - Stopfen Tap�n - Plug Tappo -	4																			
7	561829	Vis - Schraube Tornillo - Screw Vite -	4																			
8	702384	Kit petites pi�ces - Einzelteile satz Juego peque�a piezas - Small parts kit Kit piccoli pezzi - * M26-2 S�rie 3 M30-2 S�rie 3 MC 30 S�rie 3 A PARTIR DE LA MACHINE N� 253625 AB DER MASCHINE N� 253625 A PARTIR DE LA MAQUINA N� 253625 FROM MACHINE N� 253625 A PARTIR DA MACCHINA N� 253625	1																			

CARDAN DE TRANSMISSION BOITE - ESSIEU ARRIERE

KARDANKUPPLUNG GETRIEBEKASTEN - HINTERACHSE

CARDAN DE TRANSMISION CAJA - EJE TRASERO

CARDAN COUPLING GEAR BOX - REAR AXLE

CARDANO DI TRASMISSIONE CAMBIO - PONTE POSTERIORE

295 114

BP 290

CARDAN DE TRANSMISSION BOITE - ESSIEU ARRIERE
KARDANKUPPLUNG GETRIEBEKASTEN - HINTERACHSE
CARDAN DE TRANSMISION CAJA - EJE TRASERO
CARDAN COUPLING GEAR BOX - REAR AXLE
CARDANO DI TRASMISSIONE CAMBIO - PONTE POSTERIORE

M 26-4 ST3B	M 26-4H ST3B
M 30-4 ST3B	M 30-4H ST3B
M 40-4 ST3B	M 40-4H ST3B
M 50-4 ST3B	M 50-4H ST3B

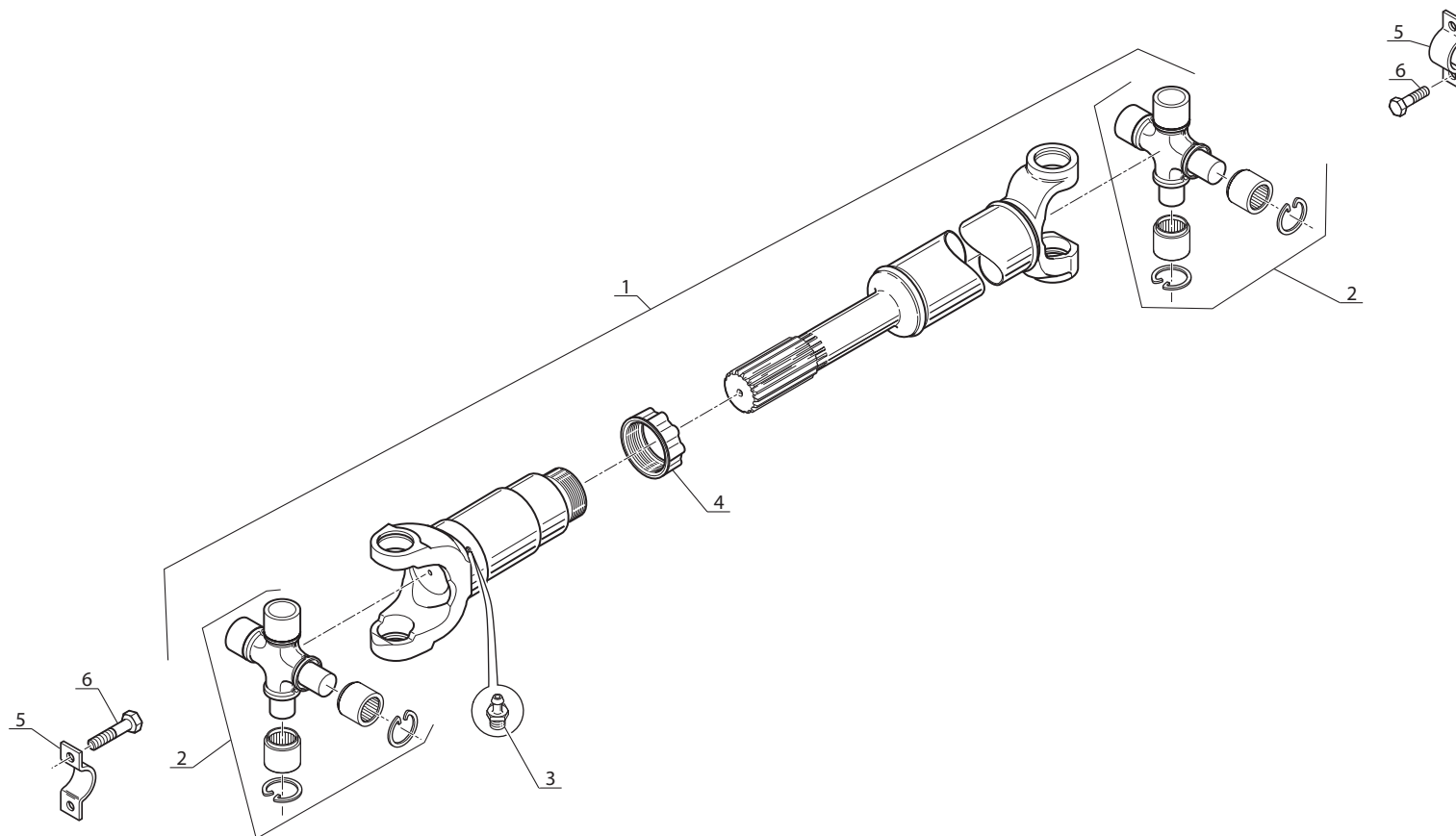

Catalogue : 295114MOD

1

CARDAN DE TRANSMISSION BOITE - ESSIEU ARRIERE
 KARDANKUPPLUNG GETRIEBEKASTEN - HINTERACHSE
 CARDAN DE TRANSMISION CAJA - EJE TRASERO
 CARDAN COUPLING GEAR BOX - REAR AXLE
 CARDANO DI TRASMISSIONE CAMBIO - PONTE POSTERIORE

Qté-Menge-Cant-Qty-Q.ta

BP

290

M

1-	295114MOD	11-
2-		12-
3-		13-
4-		14-
5-		15-
6-		16-
7-		17-
8-		18-
9-		19-
10-		20-

Rep Hinw Fig Item Rif	Numéro Teil-Nr Numero Part-Nr Part-Nr	Désignation Bezeichnung Descripcion Description Descrizione																				
			1	2	3	4	5	6	7	8	9	10	11	12	13	14	15	16	17	18	19	20
1	295114	Cardan de transmission Cardán de transmisión Cardano di trasmissione	- Kardankupplung - Cardan coupling -	1																		
2	749824	Croisillon Cruceta Crocera	- Querholz - Cross piece -	2																		
3	109754	Graisseur Engrasador Ingrassatore	- Schmiernippel - Greaser -	1																		
4	109755	Joint d'étanchéité Junta de estanqueidad Guarnizióne	- Dichtungsring - Seal -	1																		
5	109751	Demi-collier Media abrazadera Fascetta	- Halb-klemme - Half-clamp -	4																		
6	109752	Vis Tornillo Vite	- Schraube - Screw -	8																		

CARDAN DE TRANSMISSION BOITE - ESSIEU AVANT

KARDANKUPPLUNG GETRIEBEKASTEN - VORNACHSE

CARDAN DE TRANSMISION CAJA - EJE DELANTERO

CARDAN COUPLING GEAR BOX - FRONT AXLE

CARDANO DI TRASMISSIONE CAMBIO - ASSALE ANTERIORE

295 117

BP 324

CARDAN DE TRANSMISSION BOITE - ESSIEU AVANT
KARDANKUPPLUNG GETRIEBKASTEN - VORNACHSE
CARDAN DE TRANSMISION CAJA - EJE DELANTERO
CARDAN COUPLING GEAR BOX - FRONT AXLE
CARDANO DI TRASMISSIONE CAMBIO - PONTE ANTERIORE

M 26-2/4 ST3B **M 26-2/4H ST3B**
M 30-2/4 ST3B **M 30-2/4H ST3B**

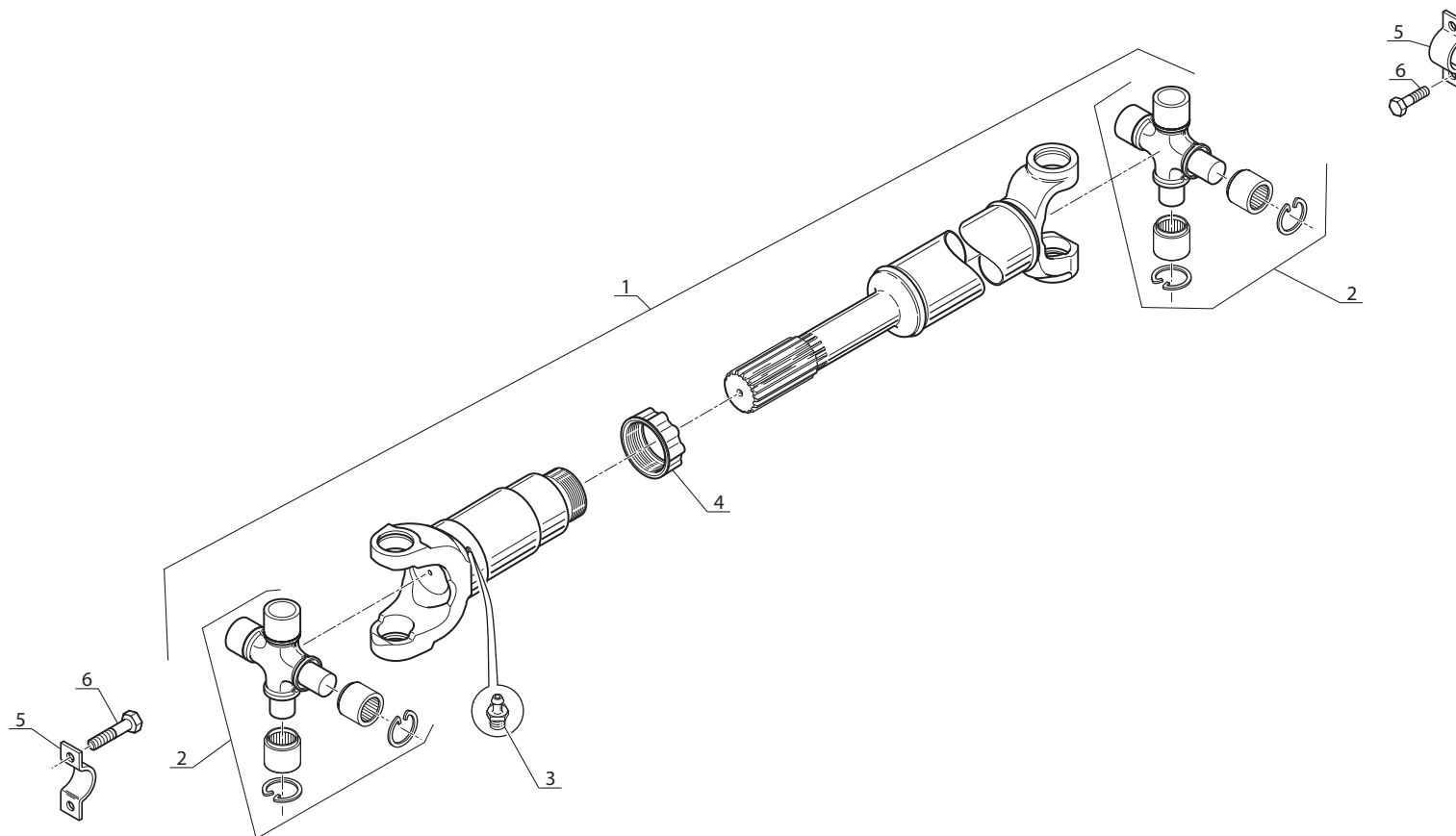

Catalogue : 295117MOD

Qté-Menge-Cant-Qty-Q.ta

BP

324

M

1

CARDAN DE TRANSMISSION BOITIER REDUCTEUR - ESSIEU AVANT
 KARDANKUPPLUNG REDUKTIONGETREIBE - VORNACHSE
 CARDAN DE TRANSMISION REDUCTOR - EJE DELANTERO
 CARDAN COUPLING REDUCTION GEAR - FRONT AXLE
 CARDANO DI TRASMISSIONE SCATOLA REDUZIONE - ASSALE ANTERIORE

1- 295117MOD 11-
 2- 12-
 3- 13-
 4- 14-
 5- 15-
 6- 16-
 7- 17-
 8- 18-
 9- 19-
 10- 20-

Rep Hinw Fig Item Rif	Numéro Teil-Nr Numero Part-Nr Part-Nr	Désignation Bezeichnung Descripcion Description Descrizione																				
			1	2	3	4	5	6	7	8	9	10	11	12	13	14	15	16	17	18	19	20
1	295117	Cardan de transmission Cardán de transmisión Cardano di trasmissione	- Kardankupplung - Cardan coupling -	1																		
2	749824	Croisillon Cruceta Crocera	- Querholz - Cross piece -	2																		
3	109754	Graisseur Engrasador Ingrassatore	- Schmiernippel - Greaser -	1																		
4	109755	Joint d'étanchéité Junta de estanqueidad Guarnizióne	- Dichtungsring - Seal -	1																		
5	109751	Demi-collier Media abrazadera Fascetta	- Halb-klemme - Half-clamp -	4																		
6	109752	Vis Tornillo Vite * M 26-2 T S3-E3 / M 30-2 T S3-E3 M 26-4 T S3-E3 / M 30-4 T S3-E3 M 40-4 T S3-E3 / M 50-4 T S3-E3 A PARTIR DE LA MACHINE N° 594571 AB DER MASCHINE N° 594571 A PARTIR DE LA MAQUINA N° 594571 FROM MACHINE N° 594571 A PARTIR DA MACCHINA N° 594571	- Schraube - Screw -	8																		

CARDAN DE TRANSMISSION BOITE - ESSIEU AVANT

KARDANKUPPLUNG GETRIEBKASTEN - VORNACHSE

CARDAN DE TRANSMISION CAJA - EJE DELANTERO

CARDAN COUPLING GEAR BOX - FRONT AXLE

CARDANO DI TRASMISSIONE CAMBIO - PONTE ANTERIORE

301500

BP 327

CARDAN DE TRANSMISSION BOITE - ESSIEU AVANT
KARDANKUPPLUNG GETRIEBKASTEN - VORNACHSE
CARDAN DE TRANSMISION CAJA - EJE DELANTERO
CARDAN COUPLING GEAR BOX - FRONT AXLE
CARDANO DI TRASMISSIONE CAMBIO - PONTE ANTERIORE

M 40-2/4 ST3B
M 50-2/4 ST3B

M 40-2/4H ST3B
M 50-2/4H ST3B

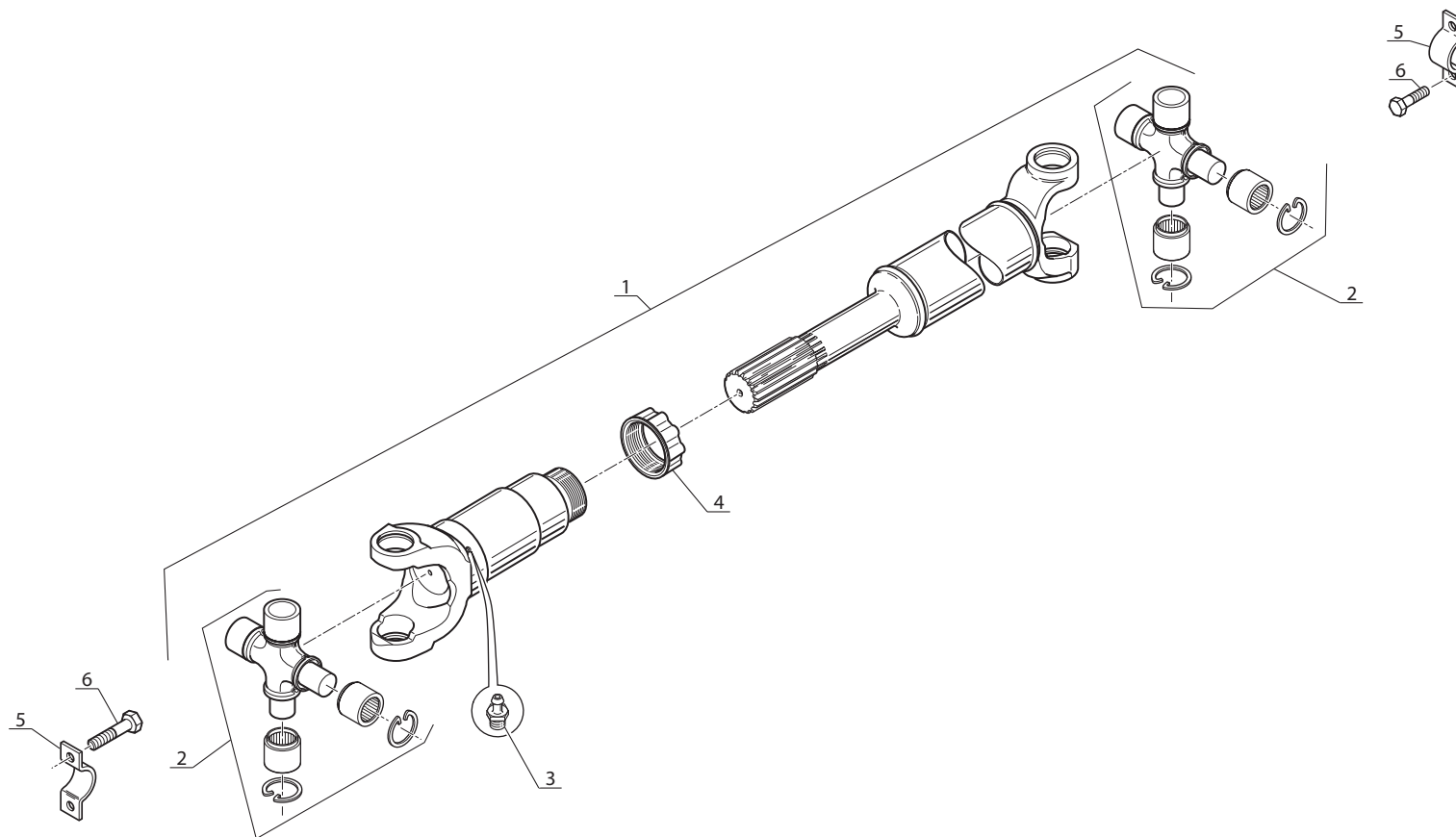

Catalogue : 301500MOD

Qté-Menge-Cant-Qty-Q.ta

BP

327

M

1

CARDAN DE TRANSMISSION BOITIER REDUCTEUR - ESSIEU AVANT
 KARDANKUPPLUNG REDUKTIONGETREIBE - VORNACHSE
 CARDAN DE TRANSMISSION REDUCTOR - EJE DELANTERO
 CARDAN COUPLING REDUCTION GEAR - FRONT AXLE
 CARDANO DI TRASMISSIONE SCATOLA REDUZIONE - ASSALE ANTERIORE

1-	301500MOD	11-
2-		12-
3-		13-
4-		14-
5-		15-
6-		16-
7-		17-
8-		18-
9-		19-
10-		20-

Rep Hinw Fig Item Rif	Numéro Teil-Nr Numero Part-Nr Part-Nr	Désignation Bezeichnung Descripcion Description Descrizione																				
			1	2	3	4	5	6	7	8	9	10	11	12	13	14	15	16	17	18	19	20
1	301500	Cardan de transmission Cardán de transmisión Cardano di trasmissione	- Kardankupplung - Cardan coupling -	1																		
2	749824	Croisillon Cruceta Crocera	- Querholz - Cross piece -	2																		
3	109754	Graisseur Engrasador Ingrassatore	- Schmiernippel - Greaser -	1																		
4	109755	Joint d'étanchéité Junta de estanqueidad Guarnizióne	- Dichtungsring - Seal -	1																		
5	109751	Demi-collier Media abrazadera Fascetta	- Halb-klemme - Half-clamp -	4																		
6	109752	Vis Tornillo Vite	- Schraube - Screw -	8																		

ESSIEU AVANT - VORNACHSE
EJE DELANTERO - FRONT AXLE
ASSALE ANTERIORE

TYPE - TYPEN
TIPO - TYPE
TIPO

112 / 203

REFERENCE - NUMMER
NUMERO - NUMBER
RIFERIMENTO

302 510

AX 8069

POUR ESSIEU AVANT
FÜR VORNACHSE
PARA EJE DELANTERO
FOR FRONT AXLE
PER PONTE ANTERIORE

- Type : **112 / 203**
- Ref : **302 510**

ESSIEU AVANT
VORNACHSE
EJE DELANTERO
FRONT AXLE
PONTE ANTERIORE

M 26-2 ST3B
M 30-2 ST3B
M 40-2 ST3B
M 50-2 ST3B

M 26-2H ST3B
M 30-2H ST3B
M 40-2H ST3B
M 50-2H ST3B

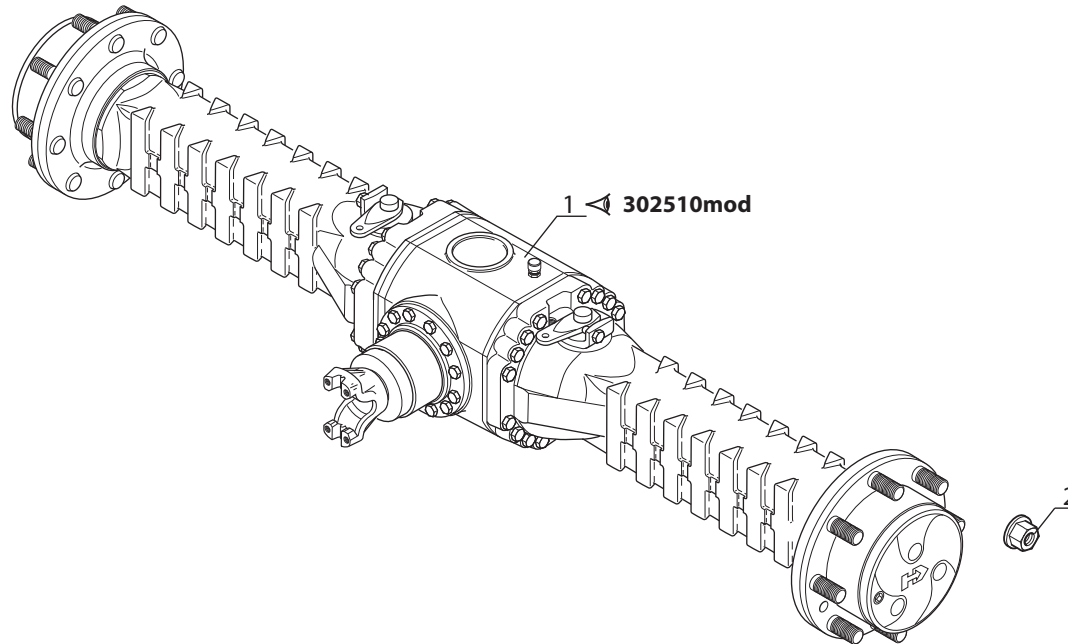

Catalogue : 647483

Rep Hinw Fig Item Rif	Numéro Teil-Nr Numero Part-Nr Part-Nr	Désignation Bezeichnung Descripcion Description Descrizione	Qte-Menge-Cant-Qty-Q.ta										AX 8069									
			1- M26- 2 ST3B 11 - M30- 2H ST3B 2- M26- 4 ST3B 12 - M30- 4H ST3B 3- M30- 2 ST3B 13 - M40- 2H ST3B 4- M30- 4 ST3B 14 - M40- 4H ST3B 5- M40- 2 ST3B 15 - M50- 2H ST3B 6- M40- 4 ST3B 16 - M50- 4H ST3B 7- M50- 2 ST3B 17 - 8- M50- 4 ST3B 18 - 9- M26- 2H ST3B 19 - 10-M26- 4H ST3B 20 -																			
			1	2	3	4	5	6	7	8	9	10	11	12	13	14	15	16	17	18	19	20
1	245767	Ecrou de roue - Radmutter - Tuerca de rueda Wheel nut - Dado ruote - Moer Mutteri	16		16		16		16		16		16		16							
2	302510	Essieu avant complet - Kompletter vornachse - Eje delantero completo - Complete front axle - Assale anteriore completo - Vooras - Etuakseli	1		1		1		1		1		1		1							

M

AX 2117

POUR ESSIEU AVANT
FÜR VORNACHSE
PARA EJE DELANTERO
FOR FRONT AXLE
PER PONTE ANTERIORE

Type : **112 - 203**
 Ref : **302 510**

CARTER ESSIEU AVANT
VORNACHSE GEHÄUSE
CARTER EJE DELANTERO
FRONT AXLE CASING
CARTER ASSALE ANTERIORE

M 26-2 ST3B
M 30-2 ST3B
M 40-2 ST3B
M 50-2 ST3B

M 26-2H ST3B
M 30-2H ST3B
M 40-2H ST3B
M 50-2H ST3B

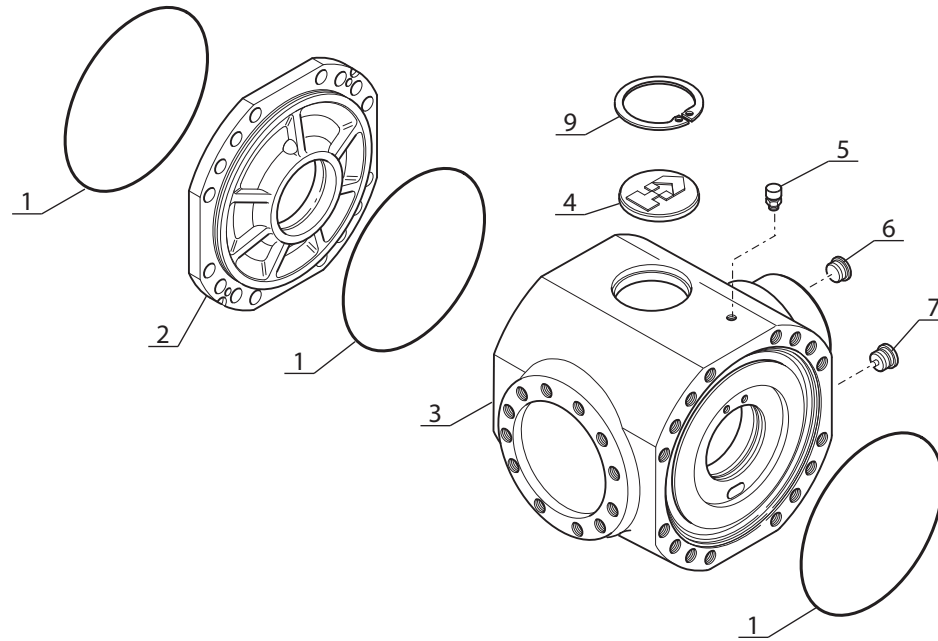

Catalogue : 302510MOD

Qté-Menge-Cant-Qty-Q.ta

AX

2117

M

1

CARTER ESSIEU AVANT
 VORNACHSE GEHAUSE
 CARTER EJE DELANTERO
 FRONT AXLE CASING
 CARTER ASSALE ANTERIORE

1- 302510MOD 11-
 2- 12-
 3- 13-
 4- 14-
 5- 15-
 6- 16-
 7- 17-
 8- 18-
 9- 19-
 10- 20-

Rep Hinw Fig Item Rif	Numéro Teil-Nr Numero Part-Nr Part-Nr	Désignation Bezeichnung Descripcion Description Descrizione	Qté-Menge-Cant-Qty-Q.ta																			
			1	2	3	4	5	6	7	8	9	10	11	12	13	14	15	16	17	18	19	20
1	106533	Joint torique Junta tórica Anello OR - "0" ring - "0" ring -	3																			
2	894514	Carter Cárter Carter - Gehäuse - Housing -	1																			
3	702754	Carter central Cárter central Carter centrale - Zentralgehäuse - Central casing -	1																			
4	602293	Bouchon Tapón Tappo - Stopfen - Plug -	1																			
5	881383	Reniflard Respiradero Sfiato - Entlüftung - Air breather -	1																			
6	603638	Bouchon Tapón Tappo - Stopfen - Plug -	1																			
7	702418	Bouchon magnétique Tapón magnetico Tappo magnetico - Magnetischstopfen - Magnetic plug -	1																			
9	133044	Circlips Aro retén Anello elastico - Sicherungsring - Circlip -	1																			

AX 2118

POUR ESSIEU AVANT
FÜR VORNACHSE
PARA EJE DELANTERO
FOR FRONT AXLE
PER PONTE ANTERIORE

Type : 112 - 203
 Ref : 302 510

DIFFERENTIEL ESSIEU AVANT
VORNACHSEDIFFERENTIAL
DIFERENCIAL EJE DELANTERO
FRONT AXLE DIFFERENTIAL
DIFFERENZIALE ASSALE ANTERIORE

M 26-2 ST3B	M 26-2H ST3B
M 30-2 ST3B	M 30-2H ST3B
M 40-2 ST3B	M 40-2H ST3B
M 50-2 ST3B	M 50-2H ST3B

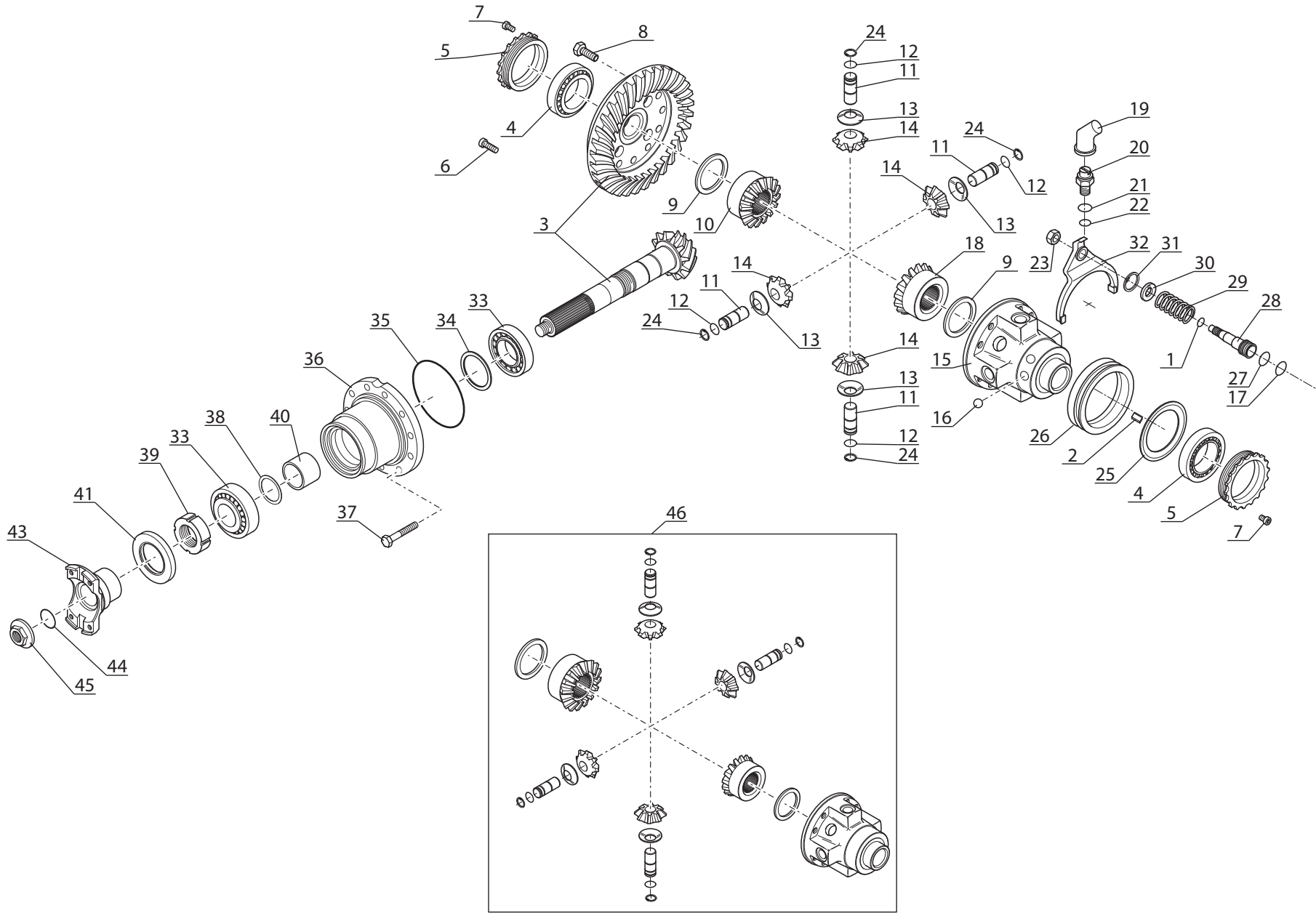

Catalogue : 302510MOD

Qté-Menge-Cant-Qty-Q.ta

AX

2118

M

1

DIFFERENTIEL ESSIEU AVANT
VORNACHSE DIFFERENTIAL
DIFERENCIAL EJE DELANTERO
FRONT AXLE DIFFERENTIAL
DIFFERENZIALE ASSALE ANTERIORE

1- 302510MOD 11-
2- 12-
3- 13-
4- 14-
5- 15-
6- 16-
7- 17-
8- 18-
9- 19-
10- 20-

Rep Hinw Fig Item Rif	Numéro Teil-Nr Numero Part-Nr Part-Nr	Désignation Bezeichnung Descripcion Description Descrizione	Qté-Menge-Cant-Qty-Q.ta																			
			1	2	3	4	5	6	7	8	9	10	11	12	13	14	15	16	17	18	19	20
1	601945	Circlips Aro retén Anello elastico	- Sicherungsring - Circlip -	1																		
2	601935	Clavette Chaveta Chiavetta	- Keil - Key -	1																		
3	601558	Couple conique Par conica Coppia conica	- Kegelpaar - Bevel drive gear -	1																		
4	106550	Roulement Rodamiento Cuscinetto	- Läger - Bearing -	2																		
5	562474	Ecrou Tuerca Dado	- Mutter - Nut -	2																		
6	749001	Vis Tornillo Vite	- Schraube - Screw -	4																		
7	748144	Vis Tornillo Vite	- Schraube - Screw -	2																		
8	601243	Vis Tornillo Vite	- Schraube - Screw -	12																		
9	562476	Rondelle Arandela Rondella	- Unterlegscheibe - Washer -	2																		
10	562477	Planétaire Planetario Planetario	- Ausgleichswellenrad - Planetary -	1																		
11	705646	Axe Eje Perno	- Bolzen - Pin -	4																		

+

Catalogue : 302510MOD

2

DIFFERENTIEL ESSIEU AVANT
 VORNACHSE DIFFERENTIAL
 DIFERENCIAL EJE DELANTERO
 FRONT AXLE DIFFERENTIAL
 DIFFERENZIALE ASSALE ANTERIORE

Qté-Menge-Cant-Qty-Q.ta

AX

2118

M

1-	302510MOD	11-
2-		12-
3-		13-
4-		14-
5-		15-
6-		16-
7-		17-
8-		18-
9-		19-
10-		20-

Rep Hinw Fig Item Rif	Numéro Teil-Nr Numero Part-Nr Part-Nr	Désignation Bezeichnung Descripcion Description Descrizione	Qté-Menge-Cant-Qty-Q.ta																			
			1	2	3	4	5	6	7	8	9	10	11	12	13	14	15	16	17	18	19	20
12	562479	Circlips Aro retén Anello elastico	- Sicherungsring - Circlip -	4																		
13	562480	Rondelle Arandela Rondella	- Unterlegscheibe - Washer -	4																		
14	705645	Satellite Satélite Satellite	- Planetenrad - Planet wheel -	4																		
15	603310	Carter différentiel Cárter diferencial Carter differenziale	- Differentialgehäuse - Differential housing -	1																		
16	601941	Bille Bola Sfera	- Kugel - Ball -	6																		
17	601943	Bague Anillo Anello	- Büchse - Bushing -	1																		
18	601937	Planétaire Planetario Planetario	- Ausgleichswellenrad - Planetary -	1																		
19	603311	Capuchon Capuchón Cappuccio	- Kappe - Cap -	1																		
20	603303	Contacteur Contactor Contattore	- Schalter - Switch -	1																		
21	704613	Joint d'étanchéité Junta de estanqueidad Guarnizione di tenuta	- Dichtungsring - Seal -	1																		
22	477473	Joint torique Junta tórica Anello OR	- "O" ring - "O" ring -	1																		

+

Catalogue : 302510MOD

3

DIFFERENTIEL ESSIEU AVANT
 VORNACHSE DIFFERENTIAL
 DIFERENCIAL EJE DELANTERO
 FRONT AXLE DIFFERENTIAL
 DIFFERENZIALE ASSALE ANTERIORE

Qté-Menge-Cant-Qty-Q.ta

AX

2118

M

1-	302510MOD	11-
2-		12-
3-		13-
4-		14-
5-		15-
6-		16-
7-		17-
8-		18-
9-		19-
10-		20-

Rep Hinw Fig Item Rif	Numéro Teil-Nr Numero Part-Nr Part-Nr	Désignation Bezeichnung Descripcion Description Descrizione																				
			1	2	3	4	5	6	7	8	9	10	11	12	13	14	15	16	17	18	19	20
23	601949	Ecrou Tuerca Dado - Mutter - Nut -	1																			
24	562486	Circlips Aro retén Anello elastico - Sicherungsring - Circlip -	4																			
25	603312	Tôle de protection Chapa de protección Lamiera di protezione - Schutzblech - Cover plate -	1																			
26	601998	Manchon Manguito Manicotto - Muffe - Coupling -	1																			
27	477693	Joint torique Junta tórica Anello OR - "0" ring - "0" ring -	1																			
28	601944	Piston Pistón Pistone - Kolben - Piston -	1																			
29	601946	Ressort Muelle Molla - Feder - Spring -	1																			
30	601947	Bouchon Tapón Tappo - Stopfen - Plug -	1																			
31	601948	Circlips Aro retén Anello elastico - Sicherungsring - Circlip -	1																			
32	601950	Fourchette Horquilla Forcella - Gabel - Fork -	1																			
33	133069	Roulement Rodamiento Cuscinetto - Läger - Bearing -	2																			



Catalogue : 302510MOD

Qté-Menge-Cant-Qty-Q.ta

AX

2118

M

4

DIFFERENTIEL ESSIEU AVANT
VORNACHSE DIFFERENTIAL
DIFERENCIAL EJE DELANTERO
FRONT AXLE DIFFERENTIAL
DIFFERENZIALE ASSALE ANTERIORE

1-	302510MOD	11-
2-		12-
3-		13-
4-		14-
5-		15-
6-		16-
7-		17-
8-		18-
9-		19-
10-		20-

Rep Hinw Fig Item Rif	Numéro Teil-Nr Numero Part-Nr Part-Nr	Désignation Bezeichnung Descripcion Description Descrizione	Qté-Menge-Cant-Qty-Q.ta																			
			1	2	3	4	5	6	7	8	9	10	11	12	13	14	15	16	17	18	19	20
34	474298	Cale d'épaisseur 0,20 mm Cala de espesor Spessore - Ausgleichscheibe - Shim -	X																			
34	474300	Cale d'épaisseur 0,30 mm Cala de espesor Spessore - Ausgleichscheibe - Shim -	X																			
34	551615	Cale d'épaisseur 0,15 mm Cala de espesor Spessore - Ausgleichscheibe - Shim -	X																			
34	552516	Cale d'épaisseur 0,10 mm Cala de espesor Spessore - Ausgleichscheibe - Shim -	X																			
35	562265	Joint torique Junta tórica Anello OR - "0" ring - "0" ring -	1																			
36	602780	Couvercle Tapadera Coperchio - Deckel - Cover -	1																			
37	749002	Vis Tornillo Vite - Schraube - Screw -	12																			
38	550556	Cale d'épaisseur 0,15 mm Cala de espesor Spessore - Ausgleichscheibe - Shim -	X																			
38	550557	Cale d'épaisseur 0,20 mm Cala de espesor Spessore - Ausgleichscheibe - Shim -	X																			
38	551616	Cale d'épaisseur 0,40 mm Cala de espesor Spessore - Ausgleichscheibe - Shim -	X																			
38	552517	Cale d'épaisseur 0,50 mm Cala de espesor Spessore - Ausgleichscheibe - Shim -	X																			

+

Catalogue : 302510MOD

5

DIFFERENTIEL ESSIEU AVANT
 VORNACHSE DIFFERENTIAL
 DIFERENCIAL EJE DELANTERO
 FRONT AXLE DIFFERENTIAL
 DIFFERENZIALE ASSALE ANTERIORE

Qté-Menge-Cant-Qty-Q.ta

AX

2118

M

Rep Hinw Fig Item Rif	Numéro Teil-Nr Numero Part-Nr Part-Nr	Désignation Bezeichnung Descripcion Description Descrizione	11- 302510MOD 11- 12- 13- 14- 15- 16- 17- 18- 19- 20-																						
			1	2	3	4	5	6	7	8	9	10	11	12	13	14	15	16	17	18	19	20			
39	133570	Ecrou Tuerca Dado - Mutter - Nut -	1																						
40	562483	Entretoise Separador Distanziale - Querstrebe - Spacer -	1																						
41	748145	Joint d'étanchéité Junta de estanqueidad Guarnizione di tenuta - Dichtring - Seal -	1																						
43	704684	Bride Flangia Flangia - Brida - Flange -	1																						
44	562472	Joint torique Junta tórica Anello OR - "0" ring - "0" ring -	1																						
45	562485	Ecrou Tuerca Dado - Mutter - Nut -	1																						
46	704612	Kit différentiel Kit diferencial Kit differeziale - Differential kit - Differential kit -	1																						

AX 2119

POUR ESSIEU AVANT
 FÜR VORNACHSE
 PARA EJE DELANTERO
 FOR FRONT AXLE
 PER PONTE ANTERIORE

Type : 112 - 203
 Ref : 302 510

REDUCTEUR ESSIEU AVANT
 VORNACHSE REDUKTIONSGETREIBE
 REDUCTOR EJE DELANTERO
 FRONT AXLE REDUCTION GEAR
 RIDUZIONE EPICICLOIDALE ASSALE ANTERIORE

M 26-2 ST3B	M 26-2H ST3B
M 30-2 ST3B	M 30-2H ST3B
M 40-2 ST3B	M 40-2H ST3B
M 50-2 ST3B	M 50-2H ST3B

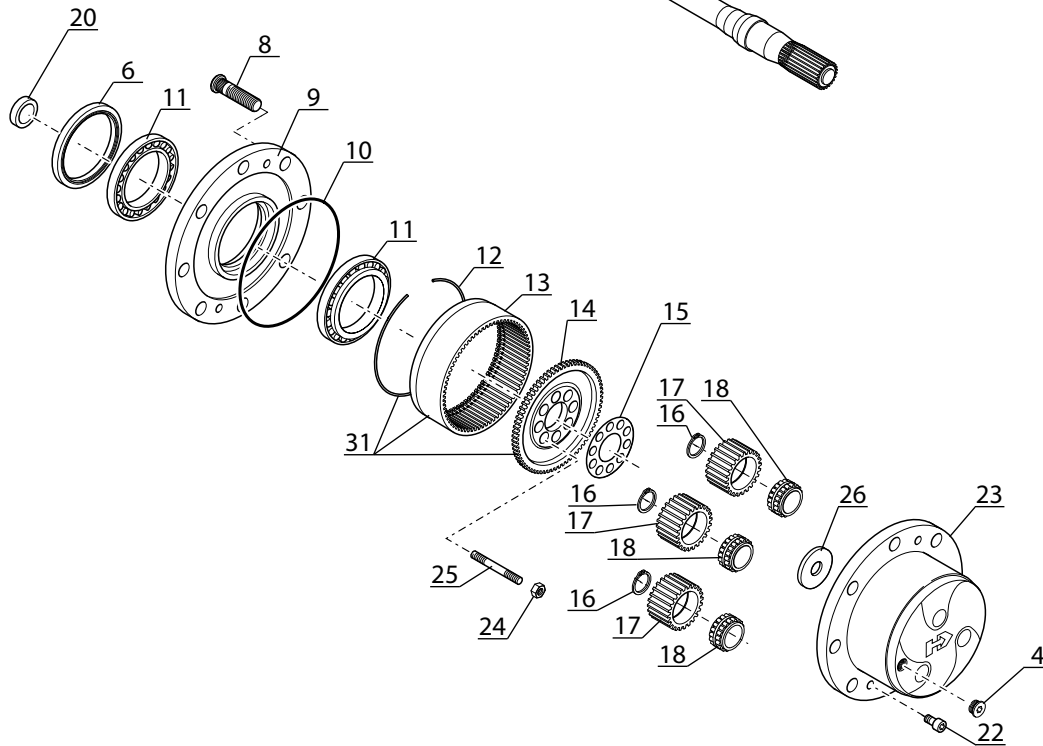
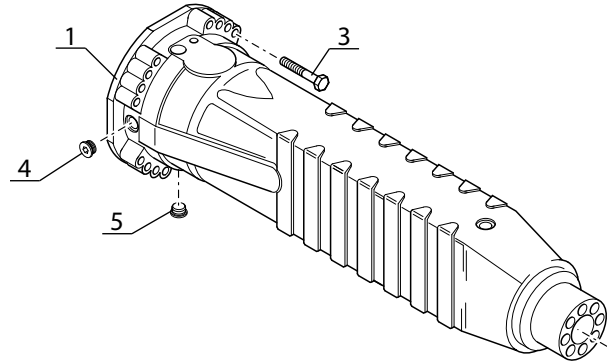

GAUCHE - LINK
 IZQUIERDO - L.H
 SINISTRA

AVANT MACHINE - FRONT OF THE MACHINE
 VOORKANT VAN MACHINE - KONEEN ETUOSA

DROIT - RECHT
 DERECHO - R.H
 DESTRA

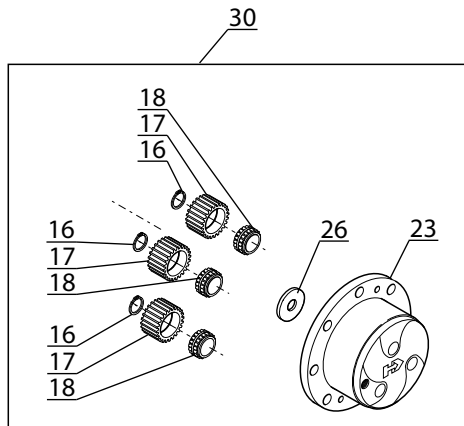

Catalogue : 302510MOD

Qté-Menge-Cant-Qty-Q.ta

AX

2119

M

1

REDUCTEUR ESSIEU AVANT
VORNACHSE REDUKTIONSGETRIEBE
REDUCTOR EJE DELANTERO
FRONT AXLE REDUCTION GEAR
RIDUTTORE ASSALE ANTERIORE

1-	302510MOD	11-
2-		12-
3-		13-
4-		14-
5-		15-
6-		16-
7-		17-
8-		18-
9-		19-
10-		20-

Rep Hinw Fig Item Rif	Numéro Teil-Nr Numero Part-Nr Part-Nr	Désignation Bezeichnung Descripcion Description Descrizione	Qté-Menge-Cant-Qty-Q.ta																			
			1	2	3	4	5	6	7	8	9	10	11	12	13	14	15	16	17	18	19	20
1	603314	Carter latéral Cárter lateral Carter laterale - - -	-	-	-	-	-	-	-	-	-	-	-	-	-	-	-	-	-	-	-	
3	702138	Vis M16x100x 40 Tornillo Vite - -	-	-	-	-	-	-	-	-	-	-	-	-	-	-	-	-	-	-	-	
4	603638	Bouchon Tapón Tappo - -	-	-	-	-	-	-	-	-	-	-	-	-	-	-	-	-	-	-	-	
5	702418	Bouchon magnétique Tapón magnetico Tappo magnetico -	-	-	-	-	-	-	-	-	-	-	-	-	-	-	-	-	-	-	-	
6	604656	Joint d'étanchéité Junta de estanqueidad Guarnizióne di tenuta -	-	-	-	-	-	-	-	-	-	-	-	-	-	-	-	-	-	-	-	
7	603315	Arbre d'entraînement Arbol de arrastre Albero trasmissione -	-	-	-	-	-	-	-	-	-	-	-	-	-	-	-	-	-	-	-	
8	704616	Goujon de roue Espárrago de rueda Prigioniero di ruota -	-	-	-	-	-	-	-	-	-	-	-	-	-	-	-	-	-	-	-	
9	601246	Moyeu de roue Cubo de rueda Mozzo ruota -	-	-	-	-	-	-	-	-	-	-	-	-	-	-	-	-	-	-	-	
10	106533	Joint torique Junta tórica Anello OR -	-	-	-	-	-	-	-	-	-	-	-	-	-	-	-	-	-	-	-	
11	562504	Roulement Rodamiento Cuscinetto -	-	-	-	-	-	-	-	-	-	-	-	-	-	-	-	-	-	-	-	
12	562514	Circlips Aro retén Anello elastico -	-	-	-	-	-	-	-	-	-	-	-	-	-	-	-	-	-	-	-	

+

Catalogue : 302510MOD

Qté-Menge-Cant-Qty-Q.ta

AX

2119

M

2

REDUCTEUR ESSIEU AVANT
 VORNACHSE REDUKTIONSGETRIEBE
 REDUCTOR EJE DELANTERO
 FRONT AXLE REDUCTION GEAR
 RIDUTTORE ASSALE ANTERIORE

1-	302510MOD	11-
2-		12-
3-		13-
4-		14-
5-		15-
6-		16-
7-		17-
8-		18-
9-		19-
10-		20-

Rep Hinw Fig Item Rif	Numéro Teil-Nr Numero Part-Nr Part-Nr	Désignation Bezeichnung Descripcion Description Descrizione																				
			1	2	3	4	5	6	7	8	9	10	11	12	13	14	15	16	17	18	19	20
13	564133	Couronne dentée (70 dents) Corona dentada Corona dentata	- Zahnkranz - Gear ring -	2																		
14	565998	Support porte couronne Soporte portacorona Supporto porta corona	- Zahnkranz träger - Ring gear bracket -	2																		
15	562515	Tôle de sécurité Chapa de seguridad Lamiere di sicurezza	- Sicherungsblech - Locking plate -	2																		
16	562508	Circlips Aro retén Anello elastico	- Sicherungsring - Circlip -	6																		
17	562509	Satellite (27 dents) Satélite Satellite	- Planetenrad - Planet wheel -	6																		
18	562510	Roulement Rodamiento Cuscinetto	- Lager - Bearing -	6																		
20	750543	Joint d'étanchéité Junta de estanqueidad Guarnizione di tenuta	- Dichtring - Seal -	2																		
22	600670	Vis Tornillo Vite	- Schraube - Screw -	4																		
23	604252	Support satellites Soporte satélite Supporto satelliti	- Planetenrad träger - Planet wheel bracket -	2																		
24	750337	Ecrou Tuerca Dado	- Mutter - Nut -	16																		
25	749982	Goujon Espárrago Prigioniero	- Stiftschraube - Stud-bolt -	16																		

+

Catalogue : 302510MOD

3

REDUCTEUR ESSIEU AVANT
 VORNACHSE REDUKTIONSGETRIEBE
 REDUCTOR EJE DELANTERO
 FRONT AXLE REDUCTION GEAR
 RIDUTTORE ASSALE ANTERIORE

Qté-Menge-Cant-Qty-Q.ta

AX

2119

M

1-	302510MOD	11-
2-		12-
3-		13-
4-		14-
5-		15-
6-		16-
7-		17-
8-		18-
9-		19-
10-		20-

Rep Hinw Fig Item Rif	Numéro Teil-Nr Numero Part-Nr Part-Nr	Désignation Bezeichnung Descripcion Descrizione
26	603640	Rondelle Arandela Rondella - Unterlegscheibe - Washer -
30	706957	Kit support satellites Kit soporte satélite Kit supporto satelliti - Planetenrad träger kit - Planet wheel bracket kit -
31	706355	Support porte couronne Soporte portacorona Supporto porta corona - Zahnkranz träger - Ring gear bracket -

1	2	3	4	5	6	7	8	9	10	11	12	13	14	15	16	17	18	19	20
2																			
2																			
1																			

AX 2120

POUR ESSIEU AVANT
FÜR VORNACHSE
PARA EJE DELANTERO
FOR FRONT AXLE
PER PONTE ANTERIORE
☐ Type : **112 - 203**
☐ Ref : **302 510**

FREIN A DISQUE A BAIN D' HUILE - ESSIEU AVANT
ÖLBADSCHIEBENBREMSE - VORNACHSE
FRENO DE DISCO A BANO DE ACEITE - EJE DELANTERO
OIL BATH DISC BRAKE - FRONT AXLE
FRENO A DISCO IN BAGNO D'OLIO ASSALE ANTERIORE

M 26-2 ST3B **M 26-2H ST3B**
M 30-2 ST3B **M 30-2H ST3B**
M 40-2 ST3B **M 40-2H ST3B**
M 50-2 ST3B **M 50-2H ST3B**

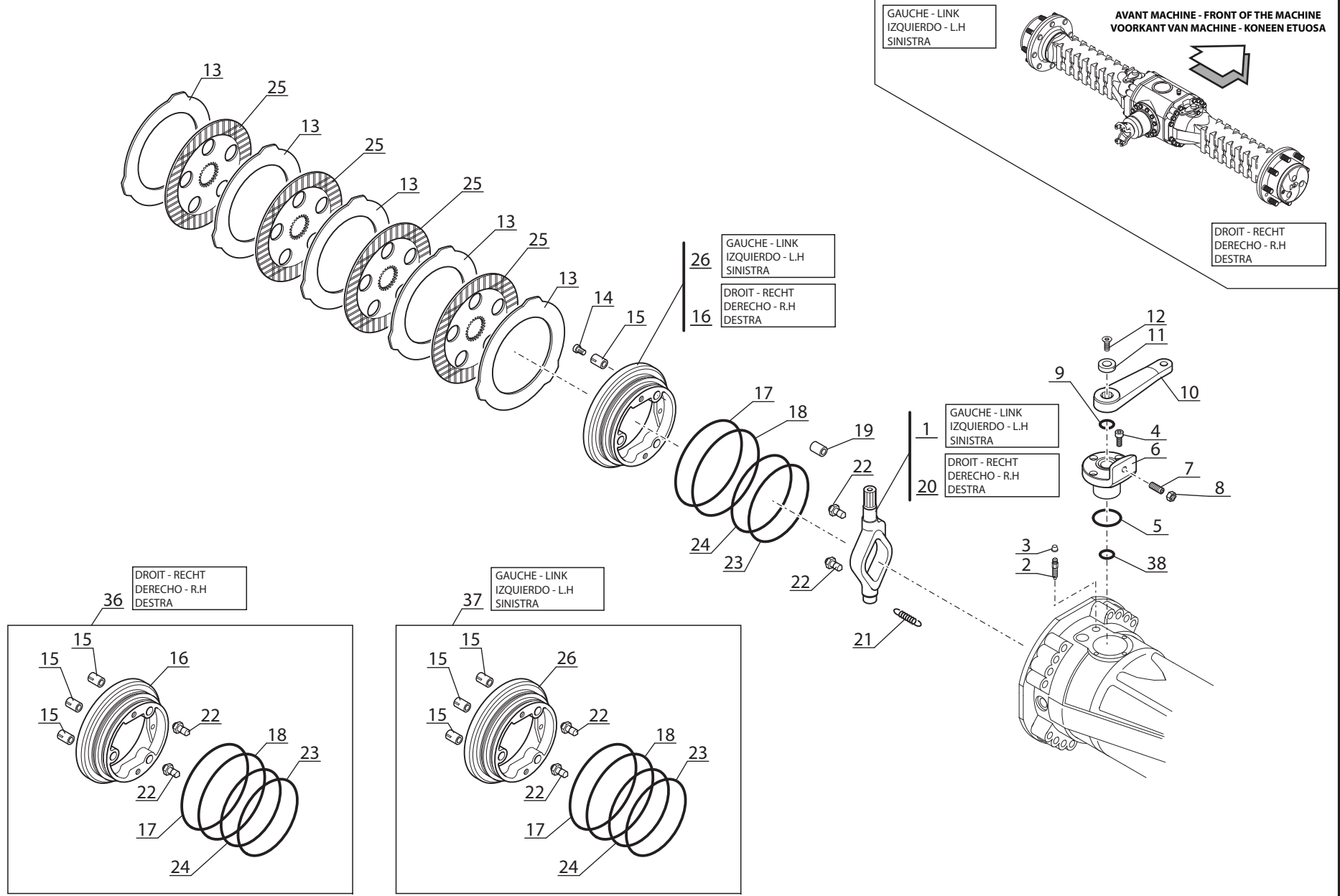

Catalogue : 302510MOD

Qté-Menge-Cant-Qty-Q.ta

AX

2120

M

1

FREIN A DISQUE A BAIN D'HUILE - ESSIEU AVANT
 ÖLBADSCHHEIBENBREMSE - VORNACHSE
 FRENO DE DISCO A BANO DE ACEITE - EJE DELANTERO
 OIL BATH DISC BRAKE - FRONT AXLE
 FRENO A DISCO IN BAGNO D'OLIO - ASSALE ANTERIORE

1- 302510MOD 11-
 2- 12-
 3- 13-
 4- 14-
 5- 15-
 6- 16-
 7- 17-
 8- 18-
 9- 19-
 10- 20-

Rep Hinw Fig Item Rif	Numéro Teil-Nr Numero Part-Nr Part-Nr	Désignation Bezeichnung Descripcion Description Descrizione																				
			1	2	3	4	5	6	7	8	9	10	11	12	13	14	15	16	17	18	19	20
1	562547	Levier Palanca Leva - Hebel - Lever -	1																			
2	106010	Vis de purge Tornillo de purga Vite spurgo - Entlüftungsschraube - Bleeder screw -	2																			
3	107796	Bouchon Tapón Tappo - Stopfen - Plug -	2																			
4	562548	Vis Tornillo Vite - Schraube - Screw -	6																			
5	475059	Joint torique Junta tórica Anello OR - "0" ring - "0" ring -	2																			
6	602218	Manchon de réduction Manguito de reducción Manicotto riduttore - Reduktionsbüchse - Reduction bush -	2																			
7	562550	Pointeau Punzón Puntalino - Nadelventil - Needle valve -	2																			
8	133088	Ecrou Tuerca Dado - Mutter - Nut -	2																			
9	476289	Joint torique Junta tórica Anello OR - "0" ring - "0" ring -	2																			
10	604253	Levier Palanca Leva - Hebel - Lever -	2																			
11	476290	Rondelle Arandela Rondella - Unterlegscheibe - Washer -	2																			

+

Catalogue : 302510MOD

			Qté-Menge-Cant-Qty-Q.ta	AX		2120														M					
2			FREIN A DISQUE A BAIN D'HUILE - ESSIEU AVANT ÖLBADSCHEIBENBREMSE - VORNACHSE FRENO DE DISCO A BANO DE ACEITE - EJE DELANTERO OIL BATH DISC BRAKE - FRONT AXLE FRENO A DISCO IN BAGNO D'OLIO - ASSALE ANTERIORE		1- 302510MOD	11-																			
Rep Hinw Fig Item Rif	Numéro Teil-Nr Numero Part-Nr Part-Nr	Désignation Bezeichnung Descripcion Description Descrizione	11- 12- 13- 14- 15- 16- 17- 18- 19- 20-																						
			1	2	3	4	5	6	7	8	9	10	11	12	13	14	15	16	17	18	19	20			
12	133199	Vis - Schraube Tornillo - Screw Vite -	2																						
13	562525	Disque intermédiaire - Zwischenscheibe Disco intermediario - Intermediate disc Disco intermediario -	10																						
14	738926	Vis de réglage - Stellschraube Tornillo de regulación - Adjusting screw Vite di regolaggio -	6																						
15	602296	Ressort - Feder Muelle - Spring Molla -	6																						
16	563905	Piston - Kolben Pistón - Piston Pistone -	1																						
17	562521	Joint anti-extrusion - Abstützdichtung Junta antiextrusión - Anti-extrusion seal Guarnizióne anti estrusione -	2																						
18	562522	Joint torique - "0" ring Junta tórica - "0" ring Anello OR -	2																						
19	107751	Pion de centrage - Zentrierstift Espiga de centraje - Centering pin Perno di centraggio -	2																						
20	562554	Levier - Hebel Palanca - Lever Leva -	1																						
21	562520	Ressort - Feder Muelle - Spring Molla -	6																						
22	107286	Pointeau - Nadelventil Punzón - Needle valve Puntalino -	4																						

+

Catalogue : 302510MOD

3

FREIN A DISQUE A BAIN D'HUILE - ESSIEU AVANT
 ÖLBADSCHEIBENBREMSE - VORNACHSE
 FRENO DE DISCO A BANO DE ACEITE - EJE DELANTERO
 OIL BATH DISC BRAKE - FRONT AXLE
 FRENO A DISCO IN BAGNO D'OLIO - ASSALE ANTERIORE

Qté-Menge-Cant-Qty-Q.ta

AX

2120

M

1-	302510MOD	11-
2-		12-
3-		13-
4-		14-
5-		15-
6-		16-
7-		17-
8-		18-
9-		19-
10-		20-

Rep Hinw Fig Item Rif	Numéro Teil-Nr Numero Part-Nr Part-Nr	Désignation Bezeichnung Descripcion Description Descrizione																				
			1	2	3	4	5	6	7	8	9	10	11	12	13	14	15	16	17	18	19	20
23	562523	Joint anti-extrusion Junta antiextrusión Guarnizióne anti estrusione	-	Abstützdichtung - Anti-extrusion seal -	2																	
24	562524	Joint torique Junta tórica Anello OR	-	"0" ring - "0" ring -	2																	
25	786594	Disque de frein Disco de freno Disco freno	-	Scheibenbremse - Brake disc -	8																	
26	563906	Piston Pistón Pistone	-	Kolben - Piston -	1																	
36	600582	Kit piston Kit pistón Kit pistone	-	Kolben kit - Piston kit -	1																	
37	600558	Kit piston Kit pistón Kit pistone	-	Kolben kit - Piston kit -	1																	
38	602007	Joint torique Junta tórica Anello OR	-	"0" ring - "0" ring -	2																	

ESSIEU AVANT - VORNACHSE
EJE DELANTERO - FRONT AXLE
ASSALE ANTERIORE

TYPE - TYPEN
TIPO - TYPE
TIPO

212 / 204

REFERENCE - NUMMER
NUMERO - NUMBER
RIFERIMENTO

302 511

AX 8070

POUR ESSIEU AVANT
FÜR VORNACHSE
PARA EJE DELANTERO
FOR FRONT AXLE
PER PONTE ANTERIORE

- Type : **112 / 204**
- Ref : **302 511**

ESSIEU AVANT
VORNACHSE
EJE DELANTERO
FRONT AXLE
PONTE ANTERIORE

M 26-4 ST3B	M 26-4H ST3B
M 30-4 ST3B	M 30-4H ST3B
M 40-4 ST3B	M 40-4H ST3B
M 50-4 ST3B	M 50-4H ST3B

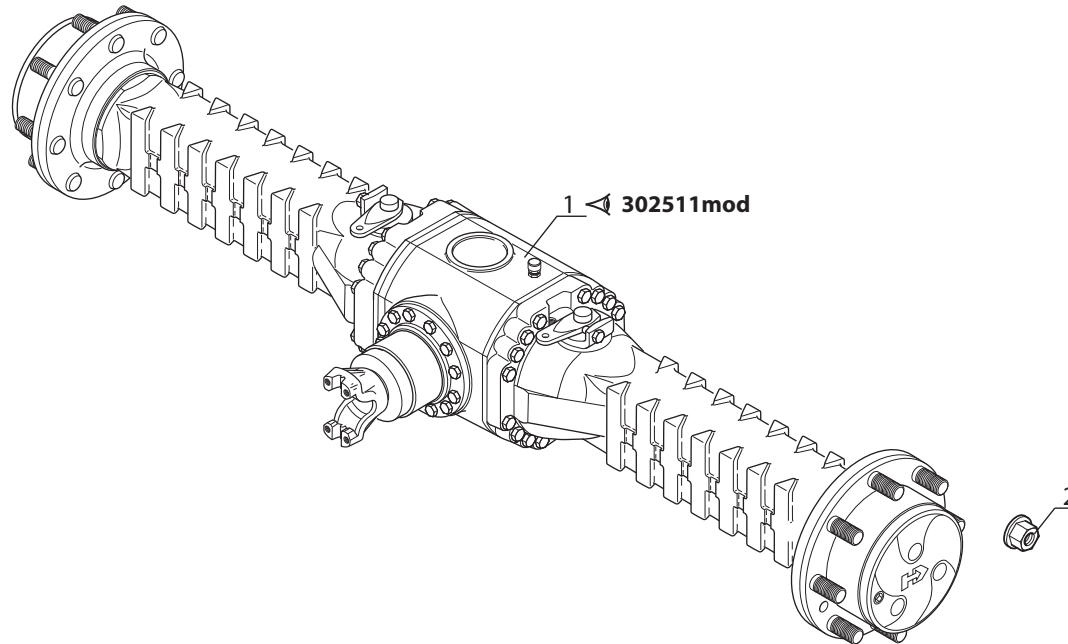

Catalogue : 647483

1	ESSIEU AVANT VORNACHSE EJE DELANTERO FRONT AXLE PONTE ANTERIORE			Qte-Menge-Cant-Qty-Q.ta										AX 8070									
	Rep Hinw Fig Item Rif	Numéro Teil-Nr Numero Part-Nr Part-Nr	Désignation Bezeichnung Descripcion Description Descrizione	1	2	3	4	5	6	7	8	9	10	11	12	13	14	15	16	17	18	19	20
1	302511	Essieu avant complet completo completo	- Kompletter vornachse - Complete front axle - Vooras - Eje delantero - Assale anteriore - Etuakseli		1		1		1		1		1		1		1		1				
2	245767	Ecrou de roue Wheel nut Mutteri	- Radmutter - Dado ruote - Tuerca de rueda - Moer		16		16		16		16		16		16		16		16				

M

AX 2121

POUR ESSIEU AVANT
FÜR VORNACHSE
PARA EJE DELANTERO
FOR FRONT AXLE
PER PONTE ANTERIORE

Type : **112 - 204**
 Ref : **302 511**

CARTER ESSIEU AVANT
VORNACHSE GEHÄUSE
CARTER EJE DELANTERO
FRONT AXLE CASING
CARTER ASSALE ANTERIORE

M 26-4 ST3B
M 30-4 ST3B
M 40-4 ST3B
M 50-4 ST3B

M 26-4H ST3B
M 30-4H ST3B
M 40-4H ST3B
M 50-4H ST3B

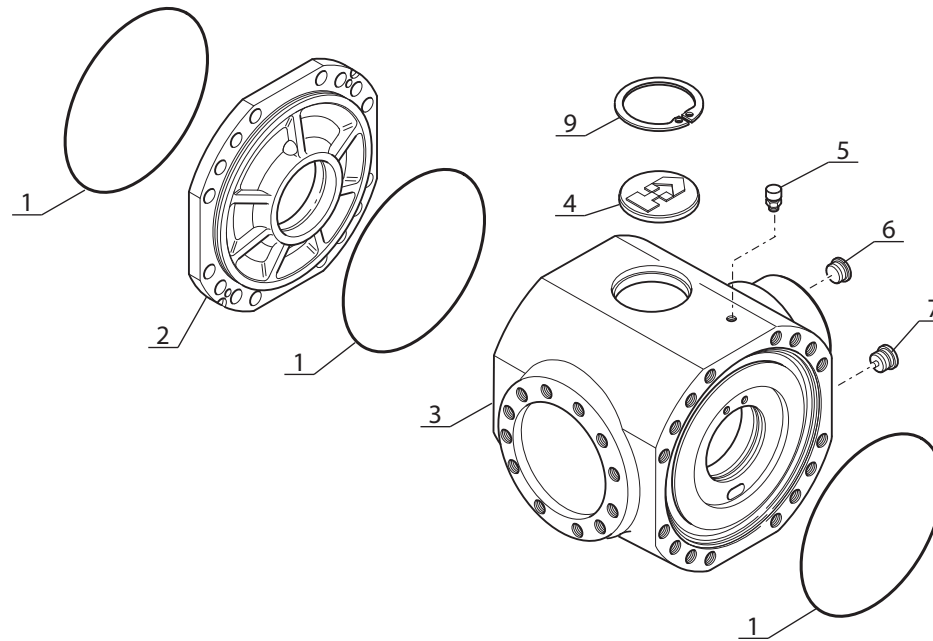

Catalogue : 302511MOD

Qté-Menge-Cant-Qty-Q.ta

AX

2121

M

1

CARTER ESSIEU AVANT
VORNACHSE GEHAUSE
CARTER EJE DELANTERO
FRONT AXLE CASING
CARTER ASSALE ANTERIORE

1- 302511MOD 11-
2- 12-
3- 13-
4- 14-
5- 15-
6- 16-
7- 17-
8- 18-
9- 19-
10- 20-

Rep Hinw Fig Item Rif	Número Teil-Nr Numero Part-Nr Part-Nr	Désignation Bezeichnung Descripcion Description Descrizione	Qté-Menge-Cant-Qty-Q.ta																			
			1	2	3	4	5	6	7	8	9	10	11	12	13	14	15	16	17	18	19	20
1	106533	Joint torique Junta tórica Anello OR - "0" ring - "0" ring -	3																			
2	894514	Carter Cárter Carter - Gehäuse - Housing -	1																			
3	604254	Carter central Cárter central Carter centrale - Zentralgehäuse - Central casing -	1																			
4	602293	Bouchon Tapón Tappo - Stopfen - Plug -	1																			
5	881383	Reniflard Respiradero Sfiato - Entlüftung - Air breather -	1																			
6	603638	Bouchon Tapón Tappo - Stopfen - Plug -	1																			
7	702418	Bouchon magnétique Tapón magnetico Tappo magnetico - Magnetischstopfen - Magnetic plug -	1																			
8	133044	Circlips Aro retén Anello elastico - Sicherungsring - Circlip -	1																			

AX 2122

POUR ESSIEU AVANT
FÜR VORNACHSE
PARA EJE DELANTERO
FOR FRONT AXLE
PER PONTE ANTERIORE

□ Type : 112 - 204
□ Ref : 302 511

DIFFERENTIEL ESSIEU AVANT
VORNACHSEDIFFERENTIAL
DIFERENCIAL EJE DELANTERO
FRONT AXLE DIFFERENTIAL
DIFFERENZIALE ASSALE ANTERIORE

M 26-4 ST3B	M 26-4H ST3B
M 30-4 ST3B	M 30-4H ST3B
M 40-4 ST3B	M 40-4H ST3B
M 50-4 ST3B	M 50-4H ST3B

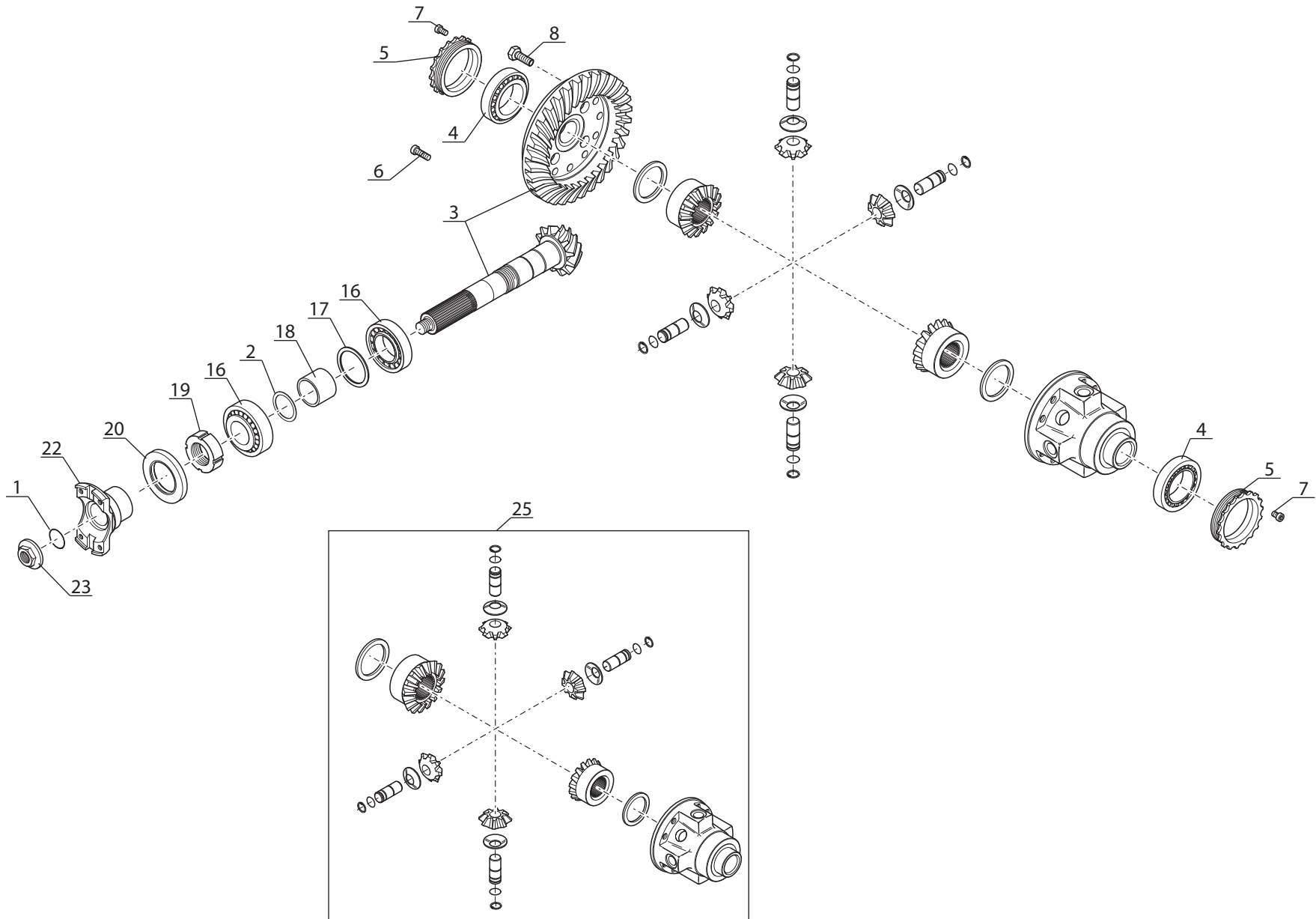

Catalogue : 302511MOD

Qté-Menge-Cant-Qty-Q.ta | **AX** | **2122** | **M**

1

DIFFERENTIEL ESSIEU AVANT
 VORNACHSE DIFFERENTIAL
 DIFERENCIAL EJE DELANTERO
 FRONT AXLE DIFFERENTIAL
 DIFFERENZIALE ASSALE ANTERIORE

1-	302511MOD	11-
2-		12-
3-		13-
4-		14-
5-		15-
6-		16-
7-		17-
8-		18-
9-		19-
10-		20-

Rep Hinw Fig Item Rif	Numéro Teil-Nr Numero Part-Nr Part-Nr	Désignation Bezeichnung Descripcion Description Descrizione																				
			1	2	3	4	5	6	7	8	9	10	11	12	13	14	15	16	17	18	19	20
1	562472	Joint torique Junta tórica Anello OR - "0" ring - "0" ring -	1																			
2	550556	Cale d'épaisseur 0,15 mm Cala de espesor Spessore - Ausgleichscheibe - Shim -	X																			
2	550557	Cale d'épaisseur 0,20 mm Cala de espesor Spessore - Ausgleichscheibe - Shim -	X																			
2	551616	Cale d'épaisseur 0,40 mm Cala de espesor Spessore - Ausgleichscheibe - Shim -	X																			
2	552517	Cale d'épaisseur 0,50 mm Cala de espesor Spessore - Ausgleichscheibe - Shim -	X																			
3	601558	Couple conique Par conica Coppia conica - Kegelpaar - Bevel drive gear -	1																			
4	106550	Roulement Rodamiento Cuscinetto - Läger - Bearing -	2																			
5	562474	Ecrou Tuerca Dado - Mutter - Nut -	2																			
6	749001	Vis Tornillo Vite - Schraube - Screw -	4																			
7	748144	Vis Tornillo Vite - Schraube - Screw -	2																			
8	601243	Vis Tornillo Vite - Schraube - Screw -	12																			

+

2

Catalogue : 302511MOD

DIFFERENTIEL ESSIEU AVANT
VORNACHSE DIFFERENTIAL
DIFERENCIAL EJE DELANTERO
FRONT AXLE DIFFERENTIAL
DIFFERENZIALE ASSALE ANTERIORE

Qté-Menge-Cant-Qty-Q.ta

AX

2122

M

Rep Hinw Fig Item Rif	Numéro Teil-Nr Numero Part-Nr Part-Nr	Désignation Bezeichnung Descripcion Description Descrizione	1- 302511MOD		11-		12-		13-		14-		15-		16-		17-		18-		19-		20-	
			1	2	3	4	5	6	7	8	9	10	11	12	13	14	15	16	17	18	19	20		
16	133069	Roulement Rodamiento Cuscinetto	-	Läger	-	Bearing	-		-		-		-		-		-		-		-		-	
17	474298	Cale d'épaisseur 0,20 mm Cala de espesor Spessore	-	Ausgleichscheibe	-	Shim	-		X															
17	474300	Cale d'épaisseur 0,30 mm Cala de espesor Spessore	-	Ausgleichscheibe	-	Shim	-		X															
17	551615	Cale d'épaisseur 0,15 mm Cala de espesor Spessore	-	Ausgleichscheibe	-	Shim	-		X															
17	552516	Cale d'épaisseur 0,10 mm Cala de espesor Spessore	-	Ausgleichscheibe	-	Shim	-		X															
18	562483	Entretoise Separador Distanziale	-	Querstrebe	-	Spacer	-		1															
19	133570	Ecrou Tuerca Dado	-	Mutter	-	Nut	-		1															
20	748145	Joint d'étanchéité Junta de estanqueidad Guarnizione di tenuta	-	Dichtring	-	Seal	-		1															
22	704684	Bride Flangia Flangia	-	Brida	-	Flange	-		1															
23	562485	Ecrou Tuerca Dado	-	Mutter	-	Nut	-		1															
25	747047	Différentiel complet Diferencial completo Differenziale completo	-	Kompletter differential	-	Complete differential	-		1															

AX 2123

POUR ESSIEU AVANT
 FÜR VORNACHSE
 PARA EJE DELANTERO
 FOR FRONT AXLE
 PER PONTE ANTERIORE

Type : 112 - 204
 Ref : 302 511

REDUCTEUR ESSIEU AVANT
 VORNACHSE REDUKTIONSGETREIBE
 REDUCTOR EJE DELANTERO
 FRONT AXLE REDUCTION GEAR
 RIDUZIONE EPICICLOIDALE ASSALE ANTERIORE

M 26-4 ST3B	M 26-4H ST3B
M 30-4 ST3B	M 30-4H ST3B
M 40-4 ST3B	M 40-4H ST3B
M 50-4 ST3B	M 50-4H ST3B

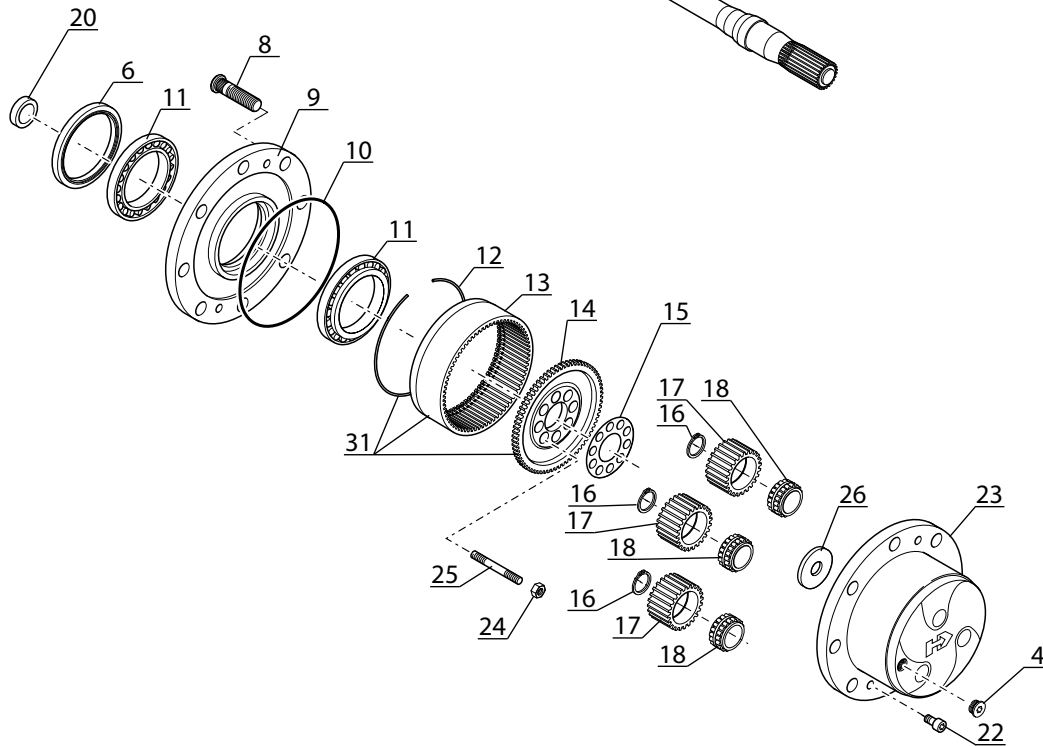
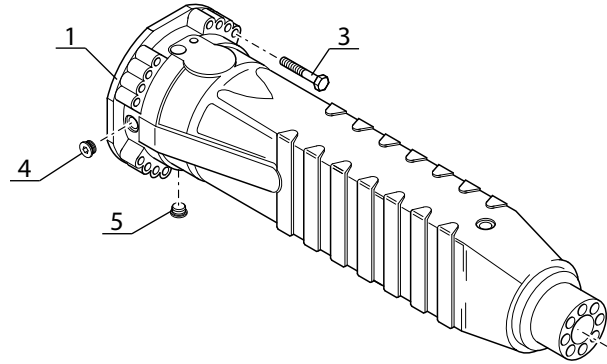

GAUCHE - LINK
 IZQUIERDO - L.H
 SINISTRA

AVANT MACHINE - FRONT OF THE MACHINE
 VOORKANT VAN MACHINE - KONEEN ETUUSA

DROIT - RECHT
 DERECHO - R.H
 DESTRA

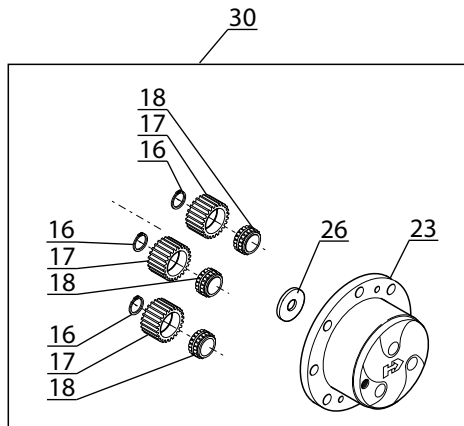

Catalogue : 302511MOD

Qté-Menge-Cant-Qty-Q.ta

AX

2123

M

1

REDUCTEUR ESSIEU AVANT
VORNACHSE REDUKTIONSGETRIEBE
REDUCTOR EJE DELANTERO
FRONT AXLE REDUCTION GEAR
RIDUTTORE ASSALE ANTERIORE

1-	302511MOD	11-
2-		12-
3-		13-
4-		14-
5-		15-
6-		16-
7-		17-
8-		18-
9-		19-
10-		20-

Rep Hinw Fig Item Rif	Numéro Teil-Nr Numero Part-Nr Part-Nr	Désignation Bezeichnung Descripcion Description Descrizione	Qté-Menge-Cant-Qty-Q.ta																			
			1	2	3	4	5	6	7	8	9	10	11	12	13	14	15	16	17	18	19	20
1	603314	Carter latéral Cárter lateral Carter laterale	-	-	-	-	-	-	-	-	-	-	-	-	-	-	-	-	-	-	-	-
3	702138	Vis M16x100x 40 Tornillo Vite	-	-	-	-	-	-	-	-	-	-	-	-	-	-	-	-	-	-	-	-
4	603638	Bouchon Tapón Tappo	-	-	-	-	-	-	-	-	-	-	-	-	-	-	-	-	-	-	-	-
5	702418	Bouchon magnétique Tapón magnetico Tappo magnetico	-	-	-	-	-	-	-	-	-	-	-	-	-	-	-	-	-	-	-	-
6	604656	Joint d'étanchéité Junta de estanqueidad Guarnizióne di tenuta	-	-	-	-	-	-	-	-	-	-	-	-	-	-	-	-	-	-	-	-
7	603315	Arbre d'entraînement Arbol de arrastre Albero trasmissione	-	-	-	-	-	-	-	-	-	-	-	-	-	-	-	-	-	-	-	-
8	704616	Goujon de roue Espárrago de rueda Prigioniero di ruota	-	-	-	-	-	-	-	-	-	-	-	-	-	-	-	-	-	-	-	-
9	601246	Moyeu de roue Cubo de rueda Mozzo ruota	-	-	-	-	-	-	-	-	-	-	-	-	-	-	-	-	-	-	-	-
10	106533	Joint torique Junta tórica Anello OR	-	-	-	-	-	-	-	-	-	-	-	-	-	-	-	-	-	-	-	-
11	562504	Roulement Rodamiento Cuscinetto	-	-	-	-	-	-	-	-	-	-	-	-	-	-	-	-	-	-	-	-
12	562514	Circlips Aro retén Anello elastico	-	-	-	-	-	-	-	-	-	-	-	-	-	-	-	-	-	-	-	-

+

Catalogue : 302511MOD

2

REDUCTEUR ESSIEU AVANT
VORNACHSE REDUKTIONSGETRIEBE
REDUCTOR EJE DELANTERO
FRONT AXLE REDUCTION GEAR
RIDUTTORE ASSALE ANTERIORE

Qté-Menge-Cant-Qty-Q.ta

AX

2123

M

1-	302511MOD	11-
2-		12-
3-		13-
4-		14-
5-		15-
6-		16-
7-		17-
8-		18-
9-		19-
10-		20-

Rep Hinw Fig Item Rif	Numéro Teil-Nr Numero Part-Nr Part-Nr	Désignation Bezeichnung Descripcion Description Descrizione																				
			1	2	3	4	5	6	7	8	9	10	11	12	13	14	15	16	17	18	19	20
13	564133	Couronne dentée (70 dents) Corona dentada Corona dentata	- Zahnkranz - Gear ring -	2																		
14	565998	Support porte couronne Soporte portacorona Supporto porta corona	- Zahnkranz träger - Ring gear bracket -	2																		
15	562515	Tôle de sécurité Chapa de seguridad Lamiera di sicurezza	- Sicherungsblech - Locking plate -	2																		
16	562508	Circlips Aro retén Anello elastico	- Sicherungsring - Circlip -	6																		
17	562509	Satellite (27 dents) Satélite Satellite	- Planetenrad - Planet wheel -	6																		
18	562510	Roulement Rodamiento Cuscinetto	- Lager - Bearing -	6																		
20	750543	Joint d'étanchéité Junta de estanqueidad Guarnizione di tenuta	- Dichtring - Seal -	2																		
22	600670	Vis Tornillo Vite	- Schraube - Screw -	4																		
23	604252	Support satellites Soporte satélite Supporto satelliti	- Planetenrad träger - Planet wheel bracket -	2																		
24	750337	Ecrou Tuerca Dado	- Mutter - Nut -	16																		
25	749982	Goujon Espárrago Prigioniero	- Stiftschraube - Stud-bolt -	16																		



Catalogue : 302511MOD

3

REDUCTEUR ESSIEU AVANT
 VORNACHSE REDUKTIONSGETRIEBE
 REDUCTOR EJE DELANTERO
 FRONT AXLE REDUCTION GEAR
 RIDUTTORE ASSALE ANTERIORE

Qté-Menge-Cant-Qty-Q.ta

AX

2123

M

1-	302511MOD	11-
2-		12-
3-		13-
4-		14-
5-		15-
6-		16-
7-		17-
8-		18-
9-		19-
10-		20-

Rep Hinw Fig Item Rif	Numéro Teil-Nr Numero Part-Nr Part-Nr	Désignation Bezeichnung Descripcion Descrizione
26	603640	Rondelle - Unterlegscheibe Arandela - Washer Rondella -
30	706957	Kit support satellites - Planetenrad träger kit Kit soporte satélite - Planet wheel bracket kit Kit supporto satelliti -
31	706355	Support porte couronne - Zahnkranz träger Soporte portacorona - Ring gear bracket Supporto porta corona -

1	2	3	4	5	6	7	8	9	10	11	12	13	14	15	16	17	18	19	20
2																			
2																			
1																			

AX 2124

POUR ESSIEU AVANT
FÜR VORNACHSE
PARA EJE DELANTERO
FOR FRONT AXLE
PER PONTE ANTERIORE

☐ Type : 112 - 204
☐ Ref : 302 511

FREIN A DISQUE A BAIN D' HUILE - ESSIEU AVANT
ÖLBADSCHREIBENBREMSE - VORNACHSE
FRENO DE DISCO A BANO DE ACEITE - EJE
DELANTERO
OIL BATH DISC BRAKE - FRONT AXLE

FRENO A DISCO IN BAGNO D'OLIO
ASSALE ANTERIORE

M 26-4 ST3B
M 30-4 ST3B
M 40-4 ST3B
M 50-4 ST3B

M 26-4H ST3B
M 30-4H ST3B
M 40-4H ST3B
M 50-4H ST3B

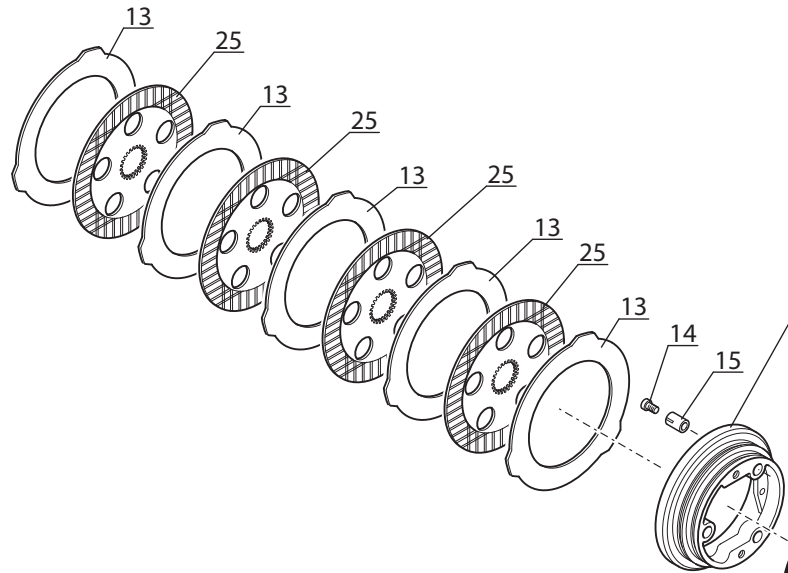

GAUCHE - LINK
IZQUIERDO - L.H
SINISTRA

DROIT - RECHT
DERECHO - R.H
DESTRA

GAUCHE - LINK
IZQUIERDO - L.H
SINISTRA

AVANT MACHINE - FRONT OF THE MACHINE
VOORKANT VAN MACHINE - KONEEN ETUOSA

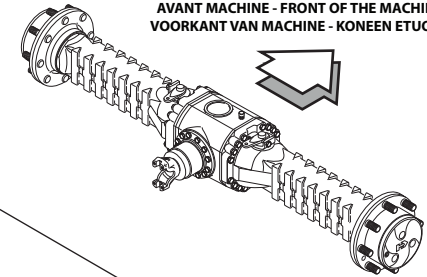

DROIT - RECHT
DERECHO - R.H
DESTRA

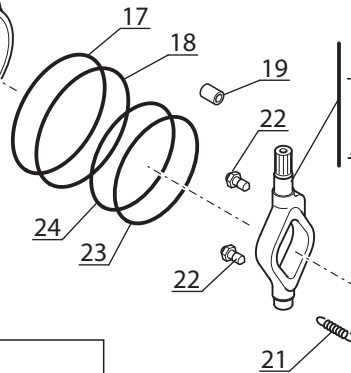

GAUCHE - LINK
IZQUIERDO - L.H
SINISTRA

DROIT - RECHT
DERECHO - R.H
DESTRA

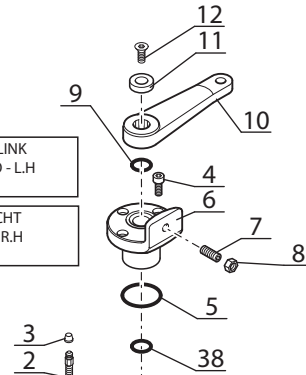

DROIT - RECHT
DERECHO - R.H
DESTRA

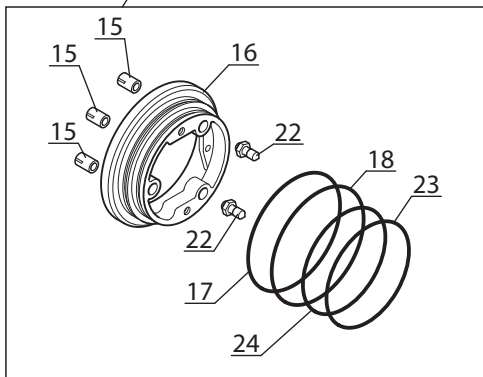

GAUCHE - LINK
IZQUIERDO - L.H
SINISTRA

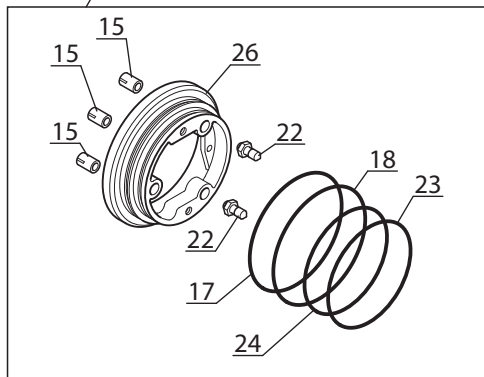

Catalogue : 302511MOD

Qté-Menge-Cant-Qty-Q.ta

AX

2124

M

1

FREIN A DISQUE A BAIN D'HUILE - ESSIEU AVANT
 ÖLBADSCHEIBENBREMSE - VORNACHSE
 FRENO DE DISCO A BANO DE ACEITE - EJE DELANTERO
 OIL BATH DISC BRAKE - FRONT AXLE
 FRENO A DISCO IN BAGNO D'OLIO - ASSALE ANTERIORE

1- 302511MOD 11-
 2- 12-
 3- 13-
 4- 14-
 5- 15-
 6- 16-
 7- 17-
 8- 18-
 9- 19-
 10- 20-

Rep Hinw Fig Item Rif	Numéro Teil-Nr Numero Part-Nr Part-Nr	Désignation Bezeichnung Descripcion Description Descrizione																				
			1	2	3	4	5	6	7	8	9	10	11	12	13	14	15	16	17	18	19	20
1	562547	Levier Palanca Leva - Hebel - Lever -	1																			
2	106010	Vis de purge Tornillo de purga Vite spurgo - Entlüftungsschraube - Bleeder screw -	2																			
3	107796	Bouchon Tapón Tappo - Stopfen - Plug -	2																			
4	562548	Vis Tornillo Vite - Schraube - Screw -	6																			
5	475059	Joint torique Junta tórica Anello OR - "0" ring - "0" ring -	2																			
6	602218	Manchon de réduction Manguito de reducción Manicotto riduttore - Reduktionsbüchse - Reduction bush -	2																			
7	562550	Pointeau Punzón Puntalino - Nadelventil - Needle valve -	2																			
8	133088	Ecrou Tuerca Dado - Mutter - Nut -	2																			
9	476289	Joint torique Junta tórica Anello OR - "0" ring - "0" ring -	2																			
10	604253	Levier Palanca Leva - Hebel - Lever -	2																			
11	476290	Rondelle Arandela Rondella - Unterlegscheibe - Washer -	2																			

+

Catalogue : 302511MOD

2

FREIN A DISQUE A BAIN D'HUILE - ESSIEU AVANT
 ÖLBADSCHEIBENBREMSE - VORNACHSE
 FRENO DE DISCO A BANO DE ACEITE - EJE DELANTERO
 OIL BATH DISC BRAKE - FRONT AXLE
 FRENO A DISCO IN BAGNO D'OLIO - ASSALE ANTERIORE

Qté-Menge-Cant-Qty-Q.ta

AX

2124

M

1-	302511MOD	11-
2-		12-
3-		13-
4-		14-
5-		15-
6-		16-
7-		17-
8-		18-
9-		19-
10-		20-

Rep Hinw Fig Item Rif	Numéro Teil-Nr Numero Part-Nr Part-Nr	Désignation Bezeichnung Descripcion Description Descrizione																				
			1	2	3	4	5	6	7	8	9	10	11	12	13	14	15	16	17	18	19	20
12	133199	Vis Tornillo Vite - Schraube - Screw -	2																			
13	562525	Disque intermédiaire Disco intermediario Disco intermediario - Zwischenscheibe - Intermediate disc -	10																			
14	738926	Vis de réglage Tornillo de regulación Vite di regolaggio - Stellschraube - Adjusting screw -	6																			
15	602296	Ressort Muelle Molla - Feder - Spring -	6																			
16	563905	Piston Pistón Pistone - Kolben - Piston -	1																			
17	562521	Joint anti-extrusion Junta antiextrusión Guarnizione anti estrusione - Abstützdichtung - Anti-extrusion seal -	2																			
18	562522	Joint torique Junta tórica Anello OR - "0" ring - "0" ring -	2																			
19	107751	Pion de centrage Espiga de centraje Perno di centraggio - Zentrierstift - Centering pin -	2																			
20	562554	Levier Palanca Leva - Hebel - Lever -	1																			
21	562520	Ressort Muelle Molla - Feder - Spring -	6																			
22	107286	Pointeau Punzón Puntalino - Nadelventil - Needle valve -	4																			

+

Catalogue : 302511MOD

3

FREIN A DISQUE A BAIN D'HUILE - ESSIEU AVANT
 ÖLBADSCHEIBENBREMSE - VORNACHSE
 FRENO DE DISCO A BANO DE ACEITE - EJE DELANTERO
 OIL BATH DISC BRAKE - FRONT AXLE
 FRENO A DISCO IN BAGNO D'OLIO - ASSALE ANTERIORE

Qté-Menge-Cant-Qty-Q.ta

AX

2124

M

1-	302511MOD	11-
2-		12-
3-		13-
4-		14-
5-		15-
6-		16-
7-		17-
8-		18-
9-		19-
10-		20-

Rep Hinw Fig Item Rif	Numéro Teil-Nr Numero Part-Nr Part-Nr	Désignation Bezeichnung Descripcion Description Descrizione																				
			1	2	3	4	5	6	7	8	9	10	11	12	13	14	15	16	17	18	19	20
23	562523	Joint anti-extrusion Junta antiextrusión Guarnizióne anti estrusione	-	Abstützdichtung Anti-extrusion seal -	2																	
24	562524	Joint torique Junta tórica Anello OR	-	"0" ring "0" ring -	2																	
25	786594	Disque de frein Disco de freno Disco freno	-	Scheibenbremse Brake disc -	8																	
26	563906	Piston Pistón Pistone	-	Kolben Piston -	1																	
36	600582	Kit piston Kit pistón Kit pistone	-	Kolben kit Piston kit -	1																	
37	600558	Kit piston Kit pistón Kit pistone	-	Kolben kit Piston kit -	1																	
38	602007	Joint torique Junta tórica Anello OR	-	"0" ring "0" ring -	2																	

ESSIEU ARRIERE - HINTERACHSE

EJE TRASERO - REAR AXLE

PONTE POSTERIORE

**TYPE - TYPEN
TIPO - TYPE
TIPO**

211 / 137

**REFERENCE - NUMMER
NUMERO - NUMBER
RIFERIMENTO**

289 504

AX 8068

POUR ESSIEU ARRIERE
FÜR INTERACHSE
PARA EJE TRASERO
FOR REAR AXLE
PER ASSALE POSTERIORE

- Type : **211 / 137**
- Ref: **289 504**

ESSIEU ARRIERE
HINTERACHSE
EJE TRASERO
REAR AXLE
ASSALE POSTERIORE

M 26-4 ST3B
M 30-4 ST3B

M 26-4H ST3B
M 30-4H ST3B

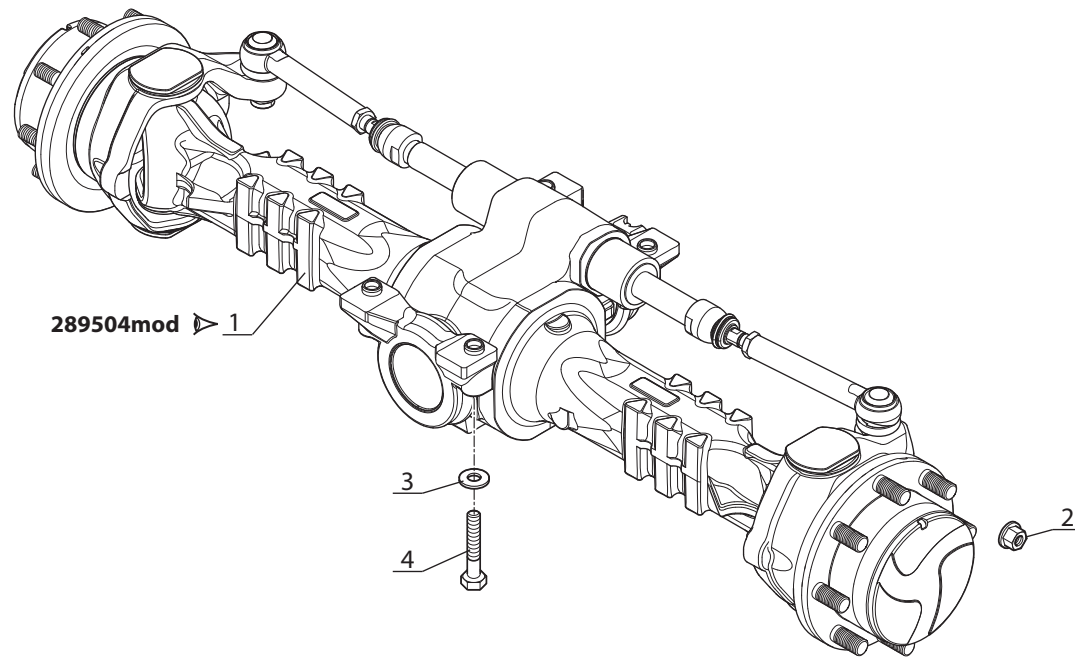

Catalogue : 647483

1	ESSIEU ARRIERE HINTERACHSE EJE TRASERO REAR AXLE ASSALE POSTERIORE			Qte-Menge-Cant-Qty-Q.ta										AX 8068									
	Rep Hinw Fig Item Rif	Numéro Teil-Nr Numero Part-Nr Part-Nr	Désignation Bezeichnung Descripcion Description Descrizione	1	2	3	4	5	6	7	8	9	10	11	12	13	14	15	16	17	18	19	20
1	289504	Essieu arrière Rear axle Taka-akseli	- Hinterachse - Assale posteriore - Eje trasero - Achteras		1		1						1		1								
2	247292	Ecrou de roue Wheel nut Mutteri	- Radmutter - Dado ruote - Tuerca de rueda - Moer		16		16						16		16								
3	42349	Rondelle W20 ZN Washer Aluslevy	- Unterlegscheibe - Rondella - Arandela - Sluitring		4		4						4		4								
4	58633	Vis H,M20-120-8.8-ZN8/C Screw Ruuvi	- Schraube - Vite - Tornillo - Schroef		4		4						4		4								

M

AX 2133

POUR ESSIEU ARRIERE
FÜR INTERACHSE
PARA EJE TRASERO
FOR REAR AXLE
PER ASSALE POSTERIORE

Type : **211 / 137**

Ref : **289 504**

CARTER ESSIEU ARRIERE
HINTERACHSE GEHÄUSE
CARTER EJE TRASERO
REAR AXLE CASING
CARTER ASSALE POSTERIORE

M 26-4 ST3B
M 30-4 ST3B

M 26-4H ST3B
M 30-4H ST3B

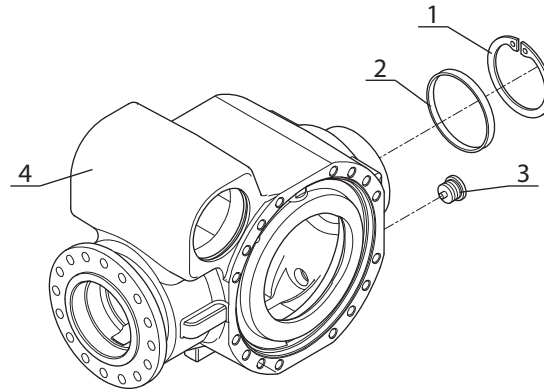

Catalogue : 289504MOD

1

CARTER ESSIEU ARRIERE
 HINTERACHSE GEHAÄSE
 CARTER EJE TRASERO
 REAR AXLE CASING
 CARTER ASSALE POSTERIORE

Qté-Menge-Cant-Qty-Q.ta

AX

2133

M

1- 289504MOD	11-
2-	12-
3-	13-
4-	14-
5-	15-
6-	16-
7-	17-
8-	18-
9-	19-
10-	20-

Rep Hinw Fig Item Rif	Numéro Teil-Nr Numero Part-Nr Part-Nr	Désignation Bezeichnung Descripcion Description Descrizione
1	133044	Circlips Aro retén Anello elastico - Sicherungsring - Circlip -
2	602293	Bouchon Tapón Tappo - Stopfen - Plug -
3	746522	Bouchon magnétique Tapón magnetico Tappo magnetico - Magnetischstopfen - Magnetic plug -
4	749007	Carter central Cárter central Carter centrale - Zentralgehäuse - Central casing -

1	2	3	4	5	6	7	8	9	10	11	12	13	14	15	16	17	18	19	20
1																			
1																			
1																			
1																			

AX 2134

POUR ESSIEU ARRIERE
FÜR INTERACHSE
PARA EJE TRASERO
FOR REAR AXLE
PER ASSALE POSTERIORE

Type: **211 / 137**
 Ref: **289 504**

DIFFERENTIEL ESSIEU ARRIERE
HINTERACHSEDIFFERENTIAL
DIFERENCIAL EJE TRASERO
REAR AXLE DIFFERENTIAL
DIFFERENZIALE ASSALE POSTERIORE

M 26-4 ST3B
M 30-4 ST3B

M 26-4H ST3B
M 30-4H ST3B

JUSQU'A L' ESSIEU
BIS DER ACHSE
HASTA EL EJE
UP TO AXLE
FINO PONTE

■ → N°: **R-HUN-119840**

A PARTIR DE L' ESSIEU
AB DER ACHSE
A PARTIR DEL EJE
FROM AXLE
A PARTIR DEL PONTE

□ → N°: **R-HUN-119841**

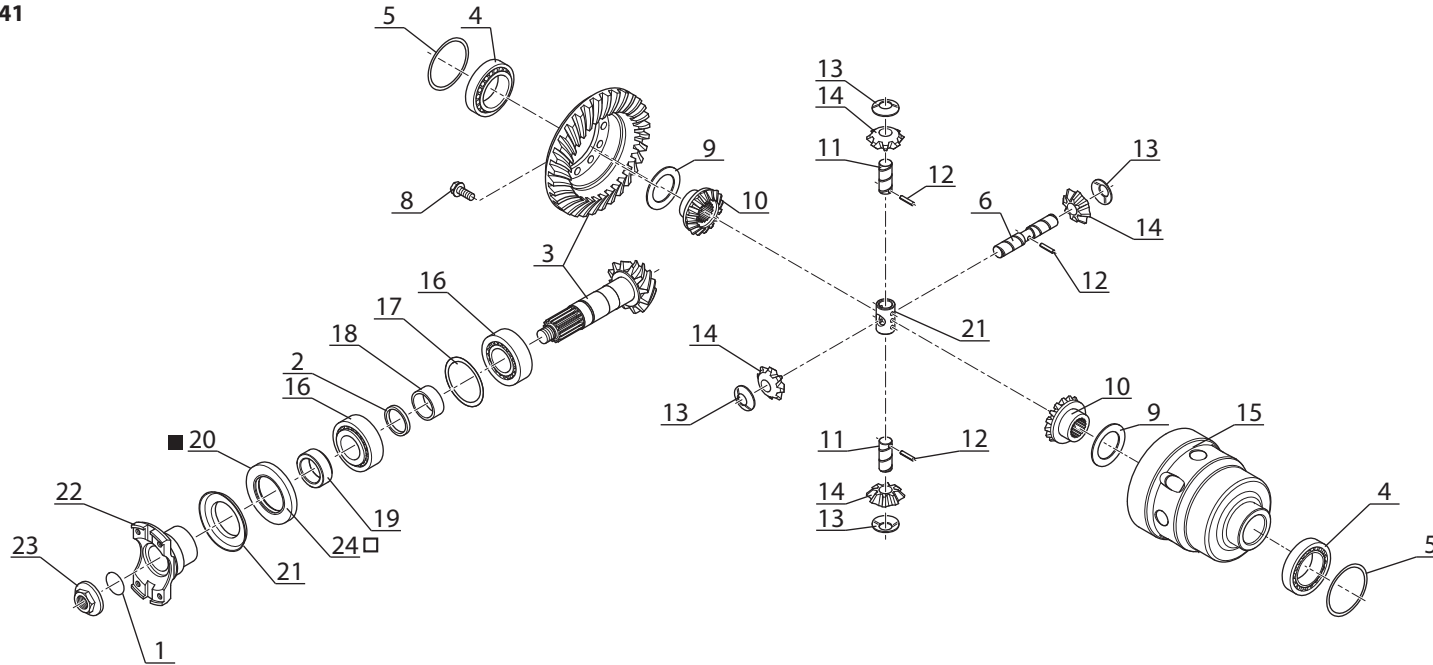

Catalogue : 289504MOD

Qté-Menge-Cant-Qty-Q.ta

AX

2134

M

1

DIFFERENTIEL ESSIEU ARRIERE
HINTERACHSEDIFFERENTIAL
DIFERENCIAL EJE TRASERO
REAR AXLE DIFFERENTIAL
DIFFERENZIALE ASSALE POSTERIORE

1- 289504MOD 11-
2- 12-
3- 13-
4- 14-
5- 15-
6- 16-
7- 17-
8- 18-
9- 19-
10- 20-

Rep Hinw Fig Item Rif	Numéro Teil-Nr Numero Part-Nr Part-Nr	Désignation Bezeichnung Descripcion Description Descrizione	Qté-Menge-Cant-Qty-Q.ta																			
			1	2	3	4	5	6	7	8	9	10	11	12	13	14	15	16	17	18	19	20
1	133026	Joint torique Junta tórica Anello OR - "0" ring - "0" ring -	1																			
2	703053	Cale d'épaisseur 5,9 mm Cala de espesor Spessore - Ausgleichscheibe - Shim -	1																			
2	703054	Cale d'épaisseur 3,08 mm Cala de espesor Spessore - Ausgleichscheibe - Shim -	1																			
3	748948	Couple conique Par conica Coppia conica - Kegelpaar - Bevel drive gear -	1																			
4	133066	Roulement à rouleaux coniques Rodamiento de rodillos cónicos Cuscinetto - Kegelwalzelager - Taper roller bearing -	2																			
5	703069	Cale d'épaisseur 0,10 mm Cala de espesor Spessore - Ausgleichscheibe - Shim -	2																			
5	703070	Cale d'épaisseur 0,15 mm Cala de espesor Spessore - Ausgleichscheibe - Shim -	2																			
5	703071	Cale d'épaisseur 0,20 mm Cala de espesor Spessore - Ausgleichscheibe - Shim -	2																			
5	703072	Cale d'épaisseur 0,30 mm Cala de espesor Spessore - Ausgleichscheibe - Shim -	2																			
6	748941	Axe Eje Perno - Bolzen - Pin -	1																			
7	745600	Croisillon Cruceta Crocera - Querholz - Cross piece -	1																			

+

Catalogue : 289504MOD

Qté-Menge-Cant-Qty-Q.ta

AX

2134

M

2

DIFFERENTIEL ESSIEU ARRIERE
HINTERACHSEDIFFERENTIAL
DIFERENCIAL EJE TRASERO
REAR AXLE DIFFERENTIAL
DIFFERENZIALE ASSALE POSTERIORE

1-	289504MOD	11-
2-		12-
3-		13-
4-		14-
5-		15-
6-		16-
7-		17-
8-		18-
9-		19-
10-		20-

Rep Hinw Fig Item Rif	Numéro Teil-Nr Numero Part-Nr Part-Nr	Désignation Bezeichnung Descripcion Description Descrizione	Qté-Menge-Cant-Qty-Q.ta																			
			1	2	3	4	5	6	7	8	9	10	11	12	13	14	15	16	17	18	19	20
8	745597	Vis Tornillo Vite - Schraube - Screw -	12																			
9	703110	Rondelle Arandela Rondella - Unterlegscheibe - Washer -	2																			
10	747311	Planétaire Planetario Planetario - Ausgleichswellenrad - Planetary -	2																			
11	748940	Axe Eje Perno - Bolzen - Pin -	2																			
12	703065	Goupille Pasador Spina - Stift - Pin -	3																			
13	703063	Rondelle Arandela Rondella - Unterlegscheibe - Washer -	4																			
14	747312	Satellite de différentiel Satélite diferencial Satellite differenziale - Ausgleichskegelrad - Differential spider pinion -	4																			
15	737456	Carter différentiel Cárter diferencial Carter differenziale - Differentialgehäuse - Differential housing -	1																			
16	703049	Roulement Rodamiento Cuscinetto - Lager - Bearing -	2																			
17	703055	Cale d'épaisseur 0,10 mm Cala de espesor Spessore - Ausgleichscheibe - Shim -	1																			
17	703056	Cale d'épaisseur 0,15 mm Cala de espesor Spessore - Ausgleichscheibe - Shim -	1																			

+

Catalogue : 289504MOD

3

DIFFERENTIEL ESSIEU ARRIERE
HINTERACHSEDIFFERENTIAL
DIFERENCIAL EJE TRASERO
REAR AXLE DIFFERENTIAL
DIFFERENZIALE ASSALE POSTERIORE

Qté-Menge-Cant-Qty-Q.ta

AX

2134

M

1-	289504MOD	11-
2-		12-
3-		13-
4-		14-
5-		15-
6-		16-
7-		17-
8-		18-
9-		19-
10-		20-

Rep Hinw Fig Item Rif	Numéro Teil-Nr Numero Part-Nr Part-Nr	Désignation Bezeichnung Descripcion Description Descrizione																					
			1	2	3	4	5	6	7	8	9	10	11	12	13	14	15	16	17	18	19	20	
17	703057	Cale d'épaisseur 0,20 mm Cala de espesor Spessore	- Ausgleichscheibe - Shim -	1																			
18	745612	Entretoise Separador Distanziale	- Querstrebe - Spacer -	1																			
19	703052	Entretoise Separador Distanziale	- Querstrebe - Spacer -	1																			
20	107293	Joint d'étanchéité Junta de estanqueidad Guarnizione	- Dichtungsring - Seal -	1																			
21	703051	Flasque Placa Flangia	- Flansch - Flange -	1																			
22	703048	Bride Flangia Flangia	- Brida - Flange -	1																			
23	475074	Ecrou Tuerca Dado	- Mutter - Nut -	1																			
24	748145	Joint d'étanchéité Junta de estanqueidad Guarnizione di tenuta	- Dichtring - Seal -	1																			

AX 2135

POUR ESSIEU ARRIERE
 FÜR INTERACHSE
 PARA EJE TRASERO
 FOR REAR AXLE
 PER ASSALE POSTERIORE

Type : **211 / 137**
 Ref: **289 504**

REDUCTEUR ESSIEU ARRIERE
 HINTERACHSE REDUKTIONSGETRIEBE
 REDUCTOR EJE TRASERO
 REAR AXLE REDUCTION GEAR
 RIDUZIONE EPICICLODALE ASSALE POSTERIORE

M 26-4 ST3B
M 30-4 ST3B

M 26-4H ST3B
M 30-4H ST3B

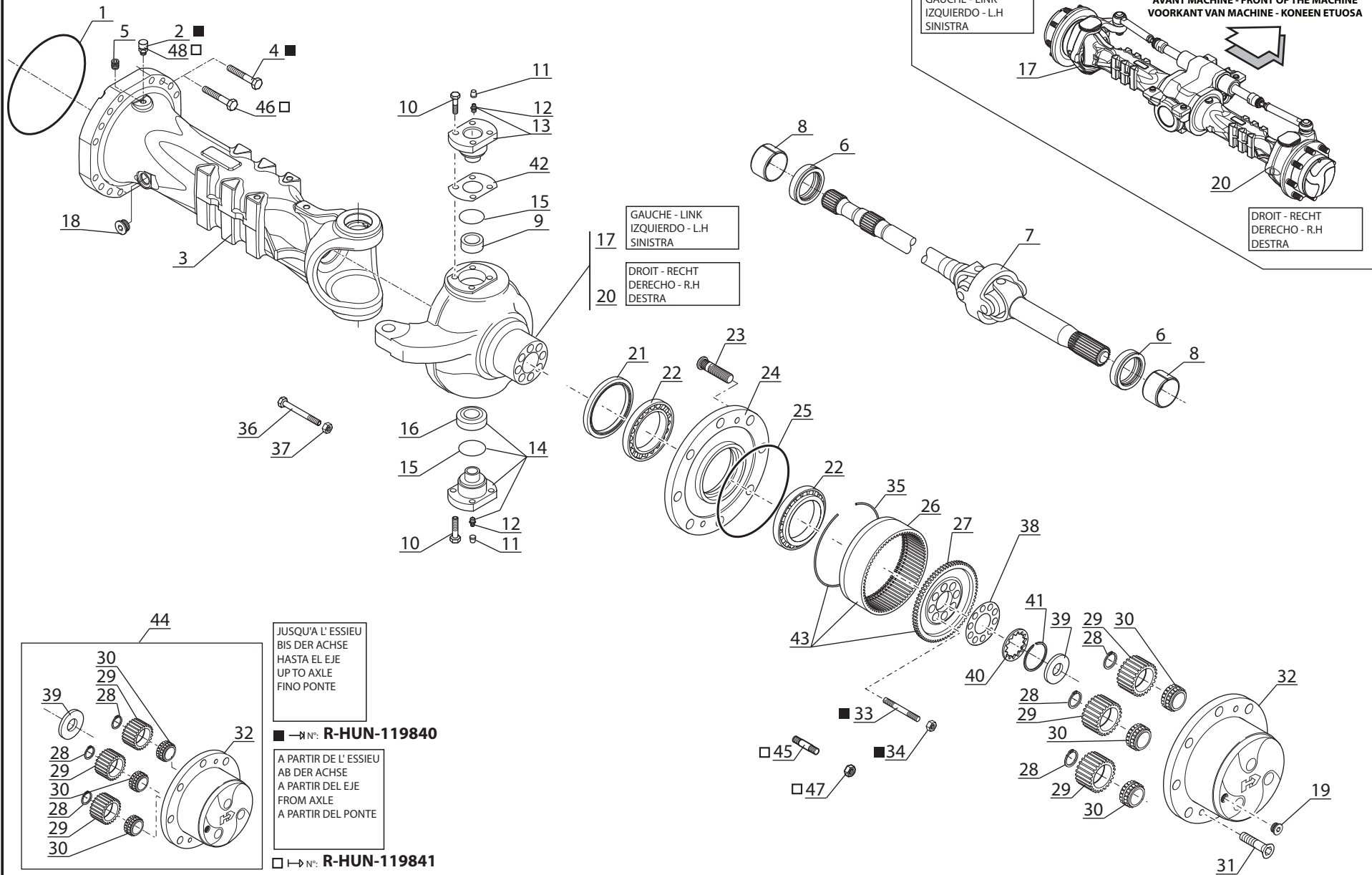

JUSQU'A L'ESSIEU
 BIS DER ACHSE
 HASTA EL EJE
 UP TO AXLE
 FINO PONTE

■ → N°: **R-HUN-119840**

A PARTIR DE L'ESSIEU
 AB DER ACHSE
 A PARTIR DEL EJE
 FROM AXLE
 A PARTIR DEL PONTE

□ → N°: **R-HUN-119841**

Catalogue : 289504MOD

Qté-Menge-Cant-Qty-Q.ta

AX

2135

M

1

REDUCTEUR ESSIEU ARRIERE
HINTERACHSE REDUKTIONSGETRIEBE
REDUCTOR EJE TRASERO
REAR AXLE REDUCTION GEAR
REDUZIONE EPICICLOIDALE ASSALE POSTERIORE

1- 289504MOD 11-
2- 12-
3- 13-
4- 14-
5- 15-
6- 16-
7- 17-
8- 18-
9- 19-
10- 20-

Rep Hinw Fig Item Rif	Numéro Teil-Nr Numero Part-Nr Part-Nr	Désignation Bezeichnung Descripcion Description Descrizione	Qté-Menge-Cant-Qty-Q.ta																			
			1	2	3	4	5	6	7	8	9	10	11	12	13	14	15	16	17	18	19	20
1	107189	Joint torique Junta tórica Anello OR - "0" ring - "0" ring -	2																			
2	562470	Reniflard Respiradero Sfiato - Entlüftung - Air breather -	1																			
3	737391	Carter latéral Cárter lateral Carter laterale - Seitlichgehäuse - Lateral axle case -	2																			
4	703074	Vis Tornillo Vite - Schraube - Screw -	32																			
5	106530	Vis de fermeture Tornillo de cierre Vite di chiusura - Verschlusschraube - Locking screw -	1																			
6	703077	Joint d'étanchéité Junta de estanqueidad Guarnizióne di tenuta - Dichtungsring - Seal -	4																			
7	737392	Arbre à cardan Arbol Albero - Kardanwelle - Shaft -	2																			
8	703076	Douille Casquillo Bussola - Fassung - Socket -	2																			
9	744806	Bague Anillo Anello - Büchse - Bushing -	2																			
10	601243	Vis Tornillo Vite - Schraube - Screw -	20																			
11	107796	Bouchon Tapón Tappo - Stopfen - Plug -	4																			

+

Catalogue : 289504MOD

2

REDUCTEUR ESSIEU ARRIERE
 HINTERACHSE REDUKTIONSGETRIEBE
 REDUCTOR EJE TRASERO
 REAR AXLE REDUCTION GEAR
 REDUZIONE EPICICLOIDALE ASSALE POSTERIORE

Qté-Menge-Cant-Qty-Q.ta

AX

2135

M

1-	289504MOD	11-
2-		12-
3-		13-
4-		14-
5-		15-
6-		16-
7-		17-
8-		18-
9-		19-
10-		20-

Rep Hinw Fig Item Rif	Numéro Teil-Nr Numero Part-Nr Part-Nr	Désignation Bezeichnung Descripcion Description Descrizione																				
			1	2	3	4	5	6	7	8	9	10	11	12	13	14	15	16	17	18	19	20
12	133103	Graisseur Engrasador Ingrassatore	- Schmiernippel - Greaser -	4																		
13	703079	Pivot de direction Pivote de dirección Perno di sterzo	- Lenkung zapfen - Pivot pin -	2																		
14	703085	Pivot de direction Pivote de dirección Perno di sterzo	- Lenkung zapfen - Pivot pin -	2																		
15	703083	Joint d'étanchéité Junta de estanqueidad Guarnizione di tenuta	- Dichtungsring - Seal -	4																		
16	703084	Douille Casquillo Bussola	- Fassung - Socket -	2																		
17	749010	Boîtier de direction Cárter de dirección Scatola di sterzo	- Lenkunggehäuse - Steering case -	1																		
18	748493	Bouchon Tapón Tappo	- Stopfen - Plug -	2																		
19	603638	Bouchon Tapón Tappo	- Stopfen - Plug -	2																		
20	749009	Boîtier de direction Cárter de dirección Scatola di sterzo	- Lenkunggehäuse - Steering case -	1																		
21	717507	Joint d'étanchéité Junta de estanqueidad Guarnizione di tenuta	- Dichtungsring - Seal -	2																		
22	601146	Roulement Rodamiento Cuscinetto	- Lager - Bearing -	4																		

+

Catalogue : 289504MOD

Qté-Menge-Cant-Qty-Q.ta

AX

2135

M

3

REDUCTEUR ESSIEU ARRIERE
HINTERACHSE REDUKTIONSGETRIEBE
REDUCTOR EJE TRASERO
REAR AXLE REDUCTION GEAR
REDUZIONE EPICICLOIDALE ASSALE POSTERIORE

1-	289504MOD	11-
2-		12-
3-		13-
4-		14-
5-		15-
6-		16-
7-		17-
8-		18-
9-		19-
10-		20-

Rep Hinw Fig Item Rif	Numéro Teil-Nr Numero Part-Nr Part-Nr	Désignation Bezeichnung Descripcion Description Descrizione	Qté-Menge-Cant-Qty-Q.ta																			
			1	2	3	4	5	6	7	8	9	10	11	12	13	14	15	16	17	18	19	20
23	702778	Goujon de roue Espárrago de rueda Prigioniero di ruota	- Stiftschraube - Wheel stud -	16																		
24	703094	Moyeu de roue Cubo de rueda Mozzo ruota	- Radnabe - Wheel hub -	2																		
25	106533	Joint torique Junta tórica Anello OR	- "0" ring - "0" ring -	2																		
26	564133	Couronne dentée (70 dents) Corona dentada Corona dentata	- Zahnkranz - Gear ring -	2																		
27	703089	Moyeu porte couronne Cubo Mozzo	- Nabe - Hub -	2																		
28	562508	Circlips Aro retén Anello elastico	- Sicherungsring - Circlip -	6																		
29	562509	Satellite (27 dents) Satélite Satellite	- Planetenrad - Planet wheel -	6																		
30	562510	Roulement Rodamiento Cuscinetto	- Lager - Bearing -	6																		
31	600670	Vis Tornillo Vite	- Schraube - Screw -	4																		
32	604252	Support satellites Soporte satélite Supporto satelliti	- Planetenrad träger - Planet wheel bracket -	2																		
33	703093	Goujon Espárrago Prigioniero	- Stiftschraube - Stud-bolt -	16																		

+

Catalogue : 289504MOD

Qté-Menge-Cant-Qty-Q.ta

AX

2135

M

4

REDUCTEUR ESSIEU ARRIERE
HINTERACHSE REDUKTIONSGETRIEBE
REDUCTOR EJE TRASERO
REAR AXLE REDUCTION GEAR
REDUZIONE EPICICLOIDALE ASSALE POSTERIORE

1-	289504MOD	11-
2-		12-
3-		13-
4-		14-
5-		15-
6-		16-
7-		17-
8-		18-
9-		19-
10-		20-

Rep Hinw Fig Item Rif	Numéro Teil-Nr Numero Part-Nr Part-Nr	Désignation Bezeichnung Descripcion Description Descrizione	Qté-Menge-Cant-Qty-Q.ta																			
			1	2	3	4	5	6	7	8	9	10	11	12	13	14	15	16	17	18	19	20
34	563219	Ecrou Tuerca Dado - Mutter - Nut -	16																			
35	562514	Circlips Aro retén Anello elastico - Sicherungsring - Circlip -	2																			
36	749008	Vis de réglage Tornillo de regulación Vite di regolaggio - Stellschraube - Adjusting screw -	4																			
37	474313	Ecrou Tuerca Dado - Mutter - Nut -	4																			
38	748945	Tôle de sécurité Chapa de seguridad Lamiera di sicurezza - Sicherungsblech - Locking plate -	2																			
39	603640	Rondelle Arandela Rondella - Unterlegscheibe - Washer -	2																			
40	748946	Bague Anillo Anello - Büchse - Bushing -	2																			
41	703092	Circlips Aro retén Anello elastico - Sicherungsring - Circlip -	2																			
42	703080	Cale d'épaisseur 0,15 mm Cala de espesor Spessore - Ausgleichscheibe - Shim -	X																			
42	703081	Cale d'épaisseur 0,20 mm Cala de espesor Spessore - Ausgleichscheibe - Shim -	X																			
42	703083	Joint d'étanchéité Junta de estanqueidad Guarnizione di tenuta - Dichtungsring - Seal -	X																			

+

Catalogue : 289504MOD

5

REDUCTEUR ESSIEU ARRIERE
 HINTERACHSE REDUKTIONSGETRIEBE
 REDUCTOR EJE TRASERO
 REAR AXLE REDUCTION GEAR
 REDUZIONE EPICICLOIDALE ASSALE POSTERIORE

Qté-Menge-Cant-Qty-Q.ta

AX

2135

M

1-	289504MOD	11-
2-		12-
3-		13-
4-		14-
5-		15-
6-		16-
7-		17-
8-		18-
9-		19-
10-		20-

Rep Hinw Fig Item Rif	Numéro Teil-Nr Numero Part-Nr Part-Nr	Désignation Bezeichnung Descripcion Description Descrizione
-----------------------------------	---	---

1	2	3	4	5	6	7	8	9	10	11	12	13	14	15	16	17	18	19	20
---	---	---	---	---	---	---	---	---	----	----	----	----	----	----	----	----	----	----	----

43	745610	Support porte couronne Soporte portacorona Supporto porta corona	- Zahnkranz träger - Ring gear bracket -
44	706957	Kit support satellites Kit soporte satélite Kit supporto satelliti	- Planetenrad träger kit - Planet wheel bracket kit -
45	787935	Goujon Espárrago Prigioniero	- Stiftschraube - Stud-bolt -
46	750540	Vis Tornillo Vite	- Schraube - Screw -
47	750506	Ecrou Tuerca Dado	- Mutter - Nut -
48	881383	Reniflard Respiradero Sfiato	- Entlüftung - Air breather -

1																				
1																				
1																				
16																				
32																				
16																				
1																				

AX 2136

POUR ESSIEU ARRIERE
FÜR INTERACHSE
PARA EJE TRASERO
FOR REAR AXLE
PER ASSALE POSTERIORE

□ Type : **211 / 137**
□ Ref : **289 504**

SYSTEME DE DIRECTION ESSIEU ARRIERE
HINTERACHSE LENKSYSTEM
SISTEMA DE DIRECCION EJE TRASERO
REAR AXLE STEERING SYSTEM
SISTEMA DI STERZO ASSALE POSTERIORE

M 26-4 ST3B
M 30-4 ST3B

M 26-4H ST3B
M 30-4H ST3B

GAUCHE - LINK
IZQUIERDO - L.H
SINISTRA

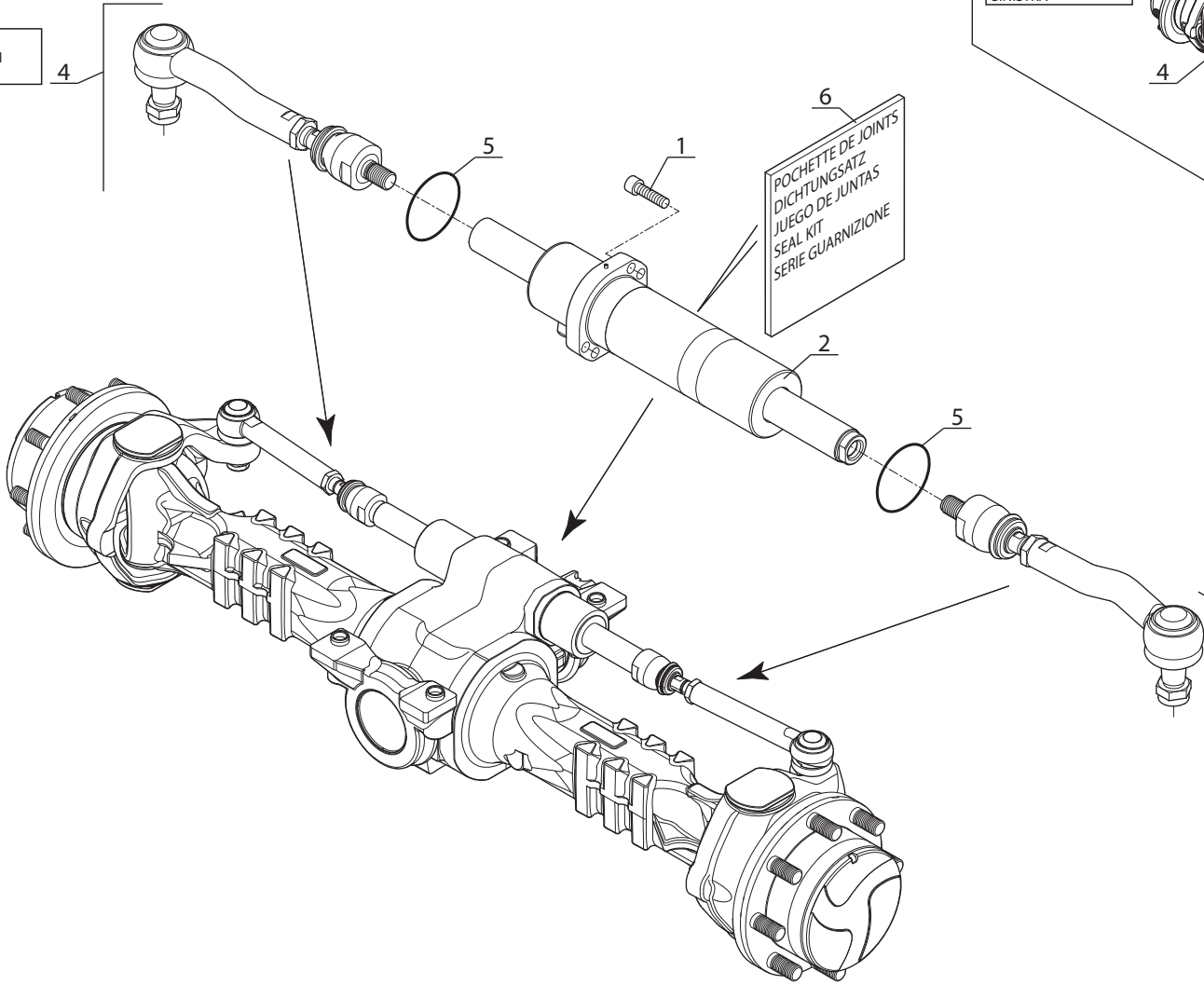

GAUCHE - LINK
IZQUIERDO - L.H
SINISTRA

POCHETTE DE JOINTS
DICHTUNGSATZ
JUEGO DE JUNTAS
SEAL KIT
SERIE GUARNIZIONE

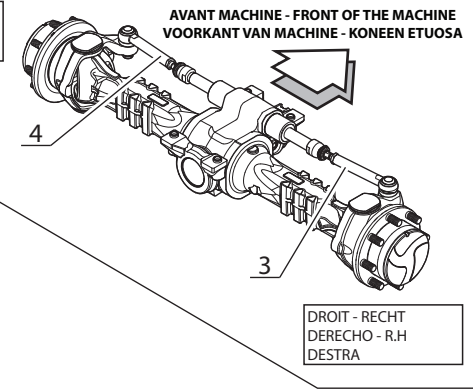

DROIT - RECHT
DERECHO - R.H
DESTRA

Catalogue : 289504MOD

Qté-Menge-Cant-Qty-Q.ta

AX

2136

M

1

SYSTEME DE DIRECTION ESSIEU ARRIERE
 HINTERACHSE LENKSYSTEM
 SISTEMA DE DIRECCION EJE TRASERO
 REAR AXLE STEERING SYSTEM
 SISTEMA DI STERZO ASSALE POSTERIORE

1-	289504MOD	11-
2-		12-
3-		13-
4-		14-
5-		15-
6-		16-
7-		17-
8-		18-
9-		19-
10-		20-

Rep Hinw Fig Item Rif	Numéro Teil-Nr Numero Part-Nr Part-Nr	Désignation Bezeichnung Descripcion Description Descrizione	Qté-Menge-Cant-Qty-Q.ta																			
			1	2	3	4	5	6	7	8	9	10	11	12	13	14	15	16	17	18	19	20
1	748947	Vis Tornillo Vite - Schraube - Screw -	4																			
2	749011	Vérin de direction Cilindro de direccion Cilindro di sterzo - Lenkzylinder - Steering cylinder -	1																			
3	705269	Barre d'accouplement Barra de acoplamiento Barra de accoppiamento - Spurstange - Cross rod -	1																			
4	705269	Barre d'accouplement Barra de acoplamiento Barra de accoppiamento - Spurstange - Cross rod -	1																			
5	703098	Bague Anillo Anello - Büchse - Bushing -	2																			

AX 2137

POUR ESSIEU ARRIERE
FÜR INTERACHSE
PARA EJE TRASERO
FOR REAR AXLE
PER ASSALE POSTERIORE

Type : **211 / 137**
 Ref : **289 504**

SUPPORT ESSIEU ARRIERE
HINTERACHSE TRÄGER
SOPORTE EJE TRASERO
REAR AXLE BRACKET
SUPPORTO ASSALE POSTERIORE

M 26-4 ST3B
M 30-4 ST3B

M 26-4H ST3B
M 30-4H ST3B

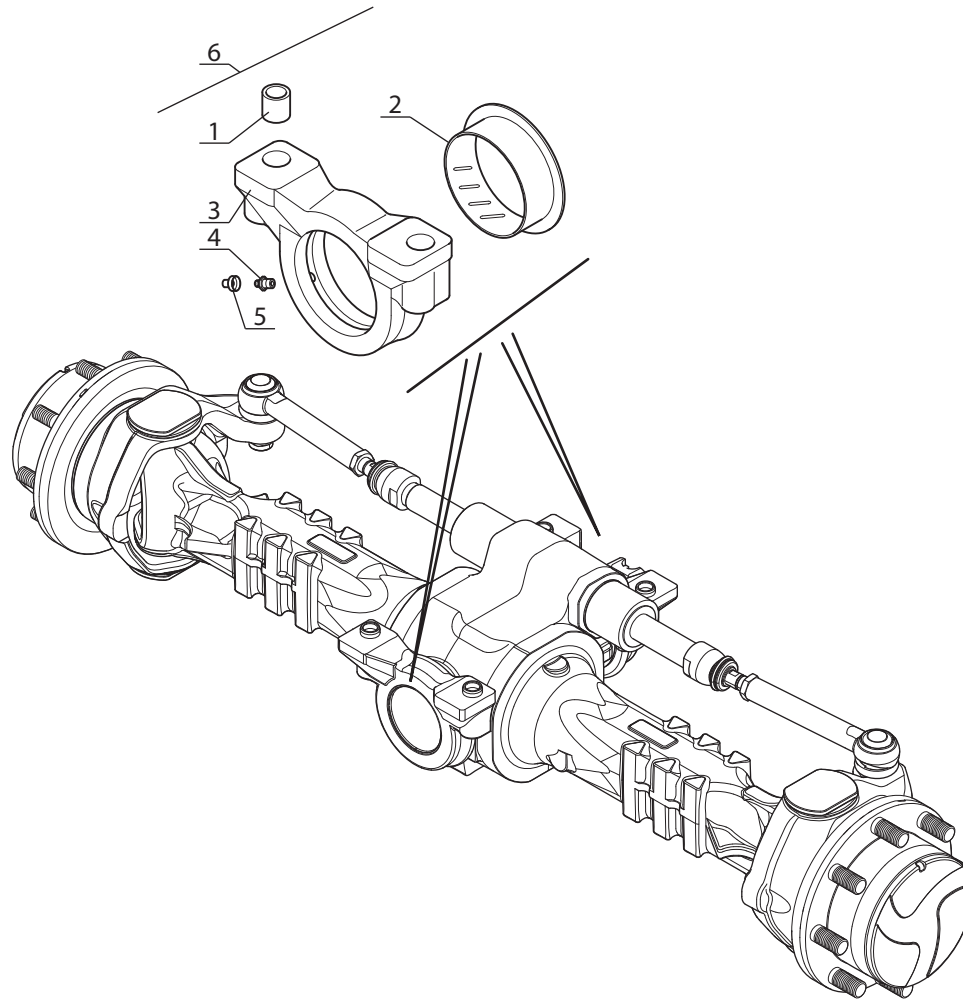

Catalogue : 289504MOD

Qté-Menge-Cant-Qty-Q.ta

AX

2137

M

1

SUPPORT ESSIEU ARRIERE
HINTERACHSE TRAGER
SOPORTE EJE TRASERO
REAR AXLE BRACKET
SUPPORTO PONTE POSTERIORE

1- 289504MOD 11-
2- 12-
3- 13-
4- 14-
5- 15-
6- 16-
7- 17-
8- 18-
9- 19-
10- 20-

Rep Hinw Fig Item Rif	Numéro Teil-Nr Numero Part-Nr Part-Nr	Désignation Bezeichnung Descripcion Description Descrizione	Qté-Menge-Cant-Qty-Q.ta																			
			1	2	3	4	5	6	7	8	9	10	11	12	13	14	15	16	17	18	19	20
1	477964	Manchon Manguito Manicotto	- Muffe - Coupling -	4																		
2	703100	Douille Casquillo Bussola	- Fassung - Socket -	2																		
3	703101	Support essieu Soporte eje Supporto assale	- Achse träger - Axle bracket -	2																		
4	133103	Graisneur Engrasador Ingrassatore	- Schmiernippel - Greaser -	2																		
5	107796	Bouchon Tapón Tappo	- Stopfen - Plug -	2																		
6	703102	Support essieu complet Soporte eje Supporto assale	- Achse träger - Axle bracket -	2																		

ESSIEU ARRIERE - HINTERACHSE

EJE TRASERO - REAR AXLE

PONTE POSTERIORE

**TYPE - TYPEN
TIPO - TYPE
TIPO**

212 / 493

**REFERENCE - NUMMER
NUMERO - NUMBER
RIFERIMENTO**

247 290

AX 8067

POUR ESSIEU ARRIERE
FÜR HINTERACHSE
PARA EJE TRASERO
FOR REAR AXLE
PER ASSALE POSTERIORE

- Type : **212 / 493**
- Ref : **247 290**

ESSIEU ARRIERE
HINTERACHSE
EJE TRASERO
REAR AXLE
ASSALE POSTERIORE

M 40-4 ST3B
M 50-4 ST3B

M 40-4H ST3B
M 50-4H ST3B

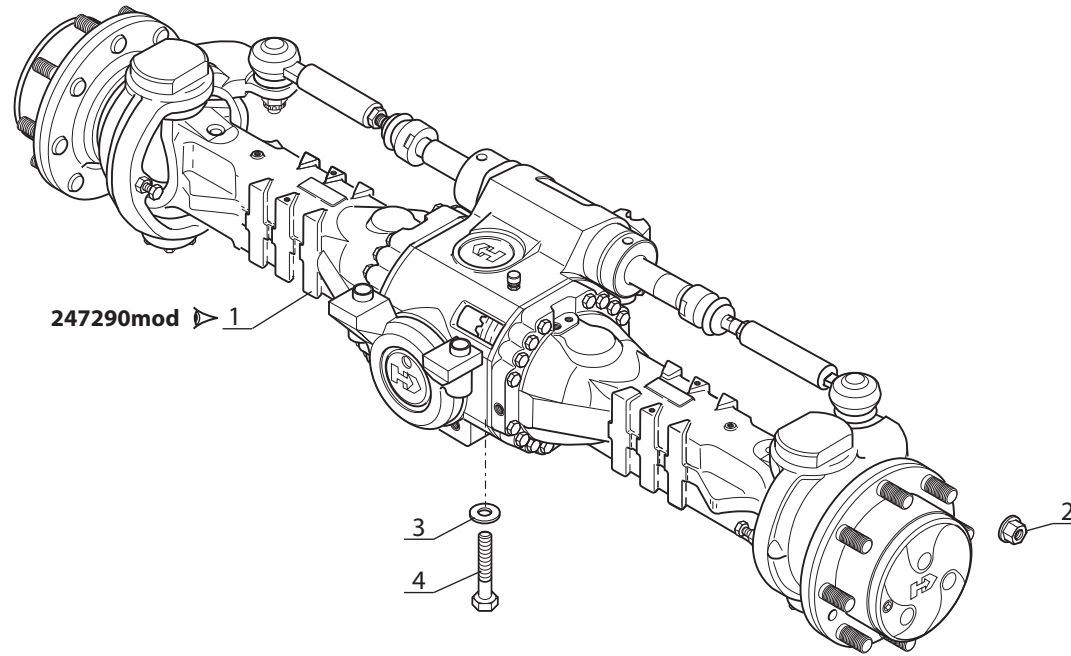

Catalogue : 647483

1	ESSIEU ARRIERE HINTERACHSE EJE TRASERO REAR AXLE ASSALE POSTERIORE			Qte-Menge-Cant-Qty-Q.ta										AX 8067									
	Rep Hinw Fig Item Rif	Numéro Teil-Nr Numero Part-Nr Part-Nr	Désignation Bezeichnung Descripcion Description Descrizione	1	2	3	4	5	6	7	8	9	10	11	12	13	14	15	16	17	18	19	20
1	247290	Essieu arrière Rear axle Taka-akseli	- Hinterachse - Assale posteriore - Eje trasero - Achteras						1		1						1		1				
2	247292	Ecrou de roue Wheel nut Mutteri	- Radmutter - Dado ruote - Tuerca de rueda - Moer						16		16						16		16				
3	42349	Rondelle W20 ZN Washer Aluslevy	- Unterlegscheibe - Rondella - Arandela - Sluitring						4		4						4		4				
4	58633	Vis H,M20-120-8.8-ZN8/C Screw Ruuvi	- Schraube - Vite - Tornillo - Schroef						4		4						4		4				

M

AX 1585

POUR ESSIEU ARRIERE
FÜR INTERACHSE
PARA EJE TRASERO
FOR REAR AXLE
PER ASSALE POSTERIORE

□ Type : **212 / 493**
□ Ref : **247 290**

CARTER ESSIEU ARRIERE
HINTERACHSE GEHÄUSE
CARTER EJE TRASERO
REAR AXLE CASING
CARTER ASSALE POSTERIORE

M 40-4 ST3B
M 50-4 ST3B

M 40-4H ST3B
M 50-4H ST3B

JUSQU'A L'ESSIEU
BIS DER ACHSE
HASTA EL EJE
UP TO AXLE
FINO PONTE

- → N°: **G.ITA.750 868**
- → N°: **M.ITA.726 703**
- ▲ → N°: **N.ITA.701 704**
- ★ → N°: **P.ITA.709 624**

A PARTIR DE L'ESSIEU
AB DER ACHSE
A PARTIR DEL EJE
FROM AXLE
A PARTIR DEL PONTE

- → N°: **G.ITA.750 869**
- → N°: **M.ITA.726 704**
- △ → N°: **N.ITA.701 705**
- ☆ → N°: **P.ITA.709 625**

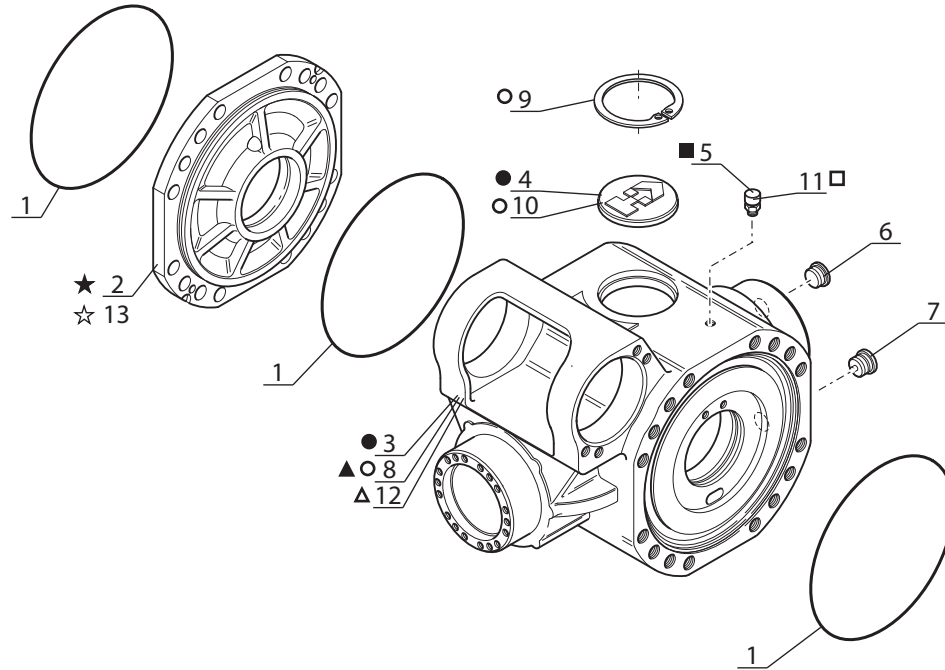

Catalogue : 247290MOD

Qté-Menge-Cant-Qty-Q.ta

AX

1585

M

1

CARTER ESSIEU ARRIERE
HINTERACHSE GEHAÄSE
CARTER EJE TRASERO
REAR AXLE CASING
CARTER ASSALE POSTERIORE

1- 247290MOD 11-
2- 12-
3- 13-
4- 14-
5- 15-
6- 16-
7- 17-
8- 18-
9- 19-
10- 20-

Rep Hinw Fig Item Rif	Numéro Teil-Nr Numero Part-Nr Part-Nr	Désignation Bezeichnung Descripcion Description Descrizione	Qté-Menge-Cant-Qty-Q.ta																			
			1	2	3	4	5	6	7	8	9	10	11	12	13	14	15	16	17	18	19	20
1	106533	Joint torique Junta tórica Anello OR - "0" ring - "0" ring -	3																			
2	562531	Carter Cárter Carter - Gehäuse - Housing -	1																			
3	562469	Carter central Cárter central Carter centrale - Zentralgehäuse - Central casing -	1																			
4	600549	Couvercle Tapadera Coperchio - Deckel - Cover -	1																			
5	562470	Reniflard Respiradero Sfiato - Entlüftung - Air breather -	1																			
6	603638	Bouchon Tapón Tappo - Stopfen - Plug -	1																			
7	702418	Bouchon magnétique Tapón magnetico Tappo magnetico - Magnetischstopfen - Magnetic plug -	1																			
8	706031	Carter central Cárter central Carter centrale - Zentralgehäuse - Central casing -	1																			
9	133044	Circlips Aro retén Anello elastico - Sicherungsring - Circlip -	1																			
10	602293	Bouchon Tapón Tappo - Stopfen - Plug -	1																			
11	881383	Reniflard Respiradero Sfiato - Entlüftung - Air breather -	1																			

+

2

Catalogue : 247290MOD

CARTER ESSIEU ARRIERE
 HINTERACHSE GEHAÄSE
 CARTER EJE TRASERO
 REAR AXLE CASING
 CARTER ASSALE POSTERIORE

Qté-Menge-Cant-Qty-Q.ta

AX

1585

M

Rep Hinw Fig Item Rif	Numéro Teil-Nr Numero Part-Nr Part-Nr	Désignation Bezeichnung Descripcion Description Descrizione																				
			1	2	3	4	5	6	7	8	9	10	11	12	13	14	15	16	17	18	19	20
12	750502	Carter central Cárter central Carter centrale	- Zentralgehäuse - Central casing -	1																		
13	894514	Carter Cárter Carter	- Gehäuse - Housing -	1																		

AX 1586

POUR ESSIEU ARRIERE
 FÜR INTERACHSE
 PARA EJE TRASERO
 FOR REAR AXLE
 PER ASSALE POSTERIORE
 □ Type: **212 / 493**
 □ Ref: **247 290**

DIFFERENTIEL ESSIEU ARRIERE
 HINTERACHSEDIFFERENTIAL
 DIFERENCIAL EJE TRASERO
 REAR AXLE DIFFERENTIAL
 DIFFERENZIALE ASSALE POSTERIORE

M 40-4 ST3B
M 50-4 ST3B

M 40-4H ST3B
M 50-4H ST3B

JUSQU'A L'ESSIEU
 BIS DER ACHSE
 HASTA EL EJE
 UP TO AXLE
 FINO PONTE

- → N°: **F.ITA.771 160**
- → N°: **G.ITA.706 924**
- ▲ → N°: **I.ITA.779 782**
- ◆ → N°: **K.ITA.727 146**
- ★ → N°: **K.ITA.759 671**

A PARTIR DE L'ESSIEU
 AB DER ACHSE
 A PARTIR DEL EJE
 FROM AXLE
 A PARTIR DEL PONTE

- → N°: **F.ITA.771 161**
- → N°: **G.ITA.706 925**
- △ → N°: **I.ITA.779 783**
- ◇ → N°: **K.ITA.727 147**
- ☆ → N°: **K.ITA.759 672**

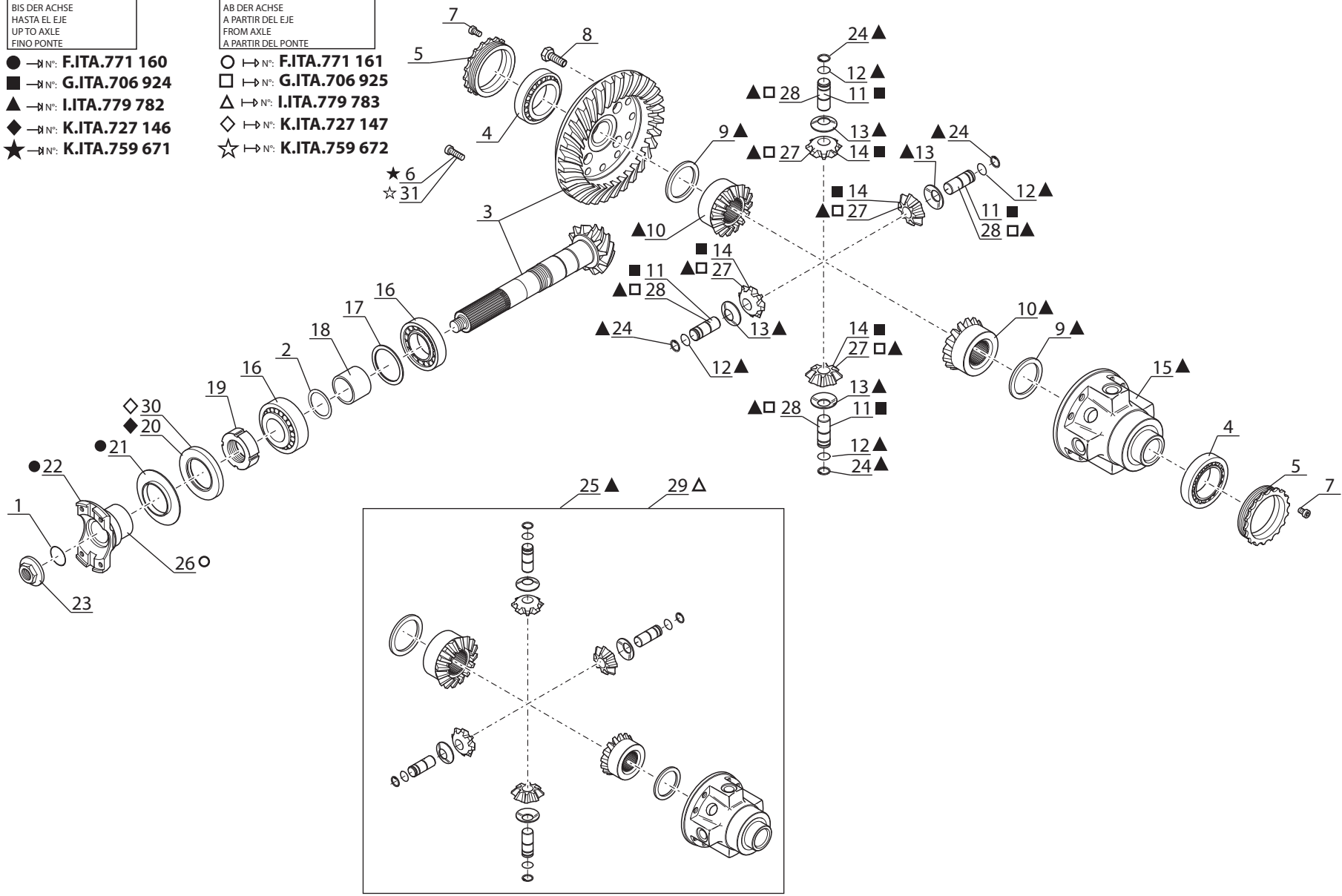

Catalogue : 247290MOD

Qté-Menge-Cant-Qty-Q.ta

AX

1586

M

1

DIFFERENTIEL ESSIEU ARRIERE
HINTERACHSEDIFFERENTIAL
DIFERENCIAL EJE TRASERO
REAR AXLE DIFFERENTIAL
DIFFERENZIALE ASSALE POSTERIORE

1- 247290MOD 11-
2- 12-
3- 13-
4- 14-
5- 15-
6- 16-
7- 17-
8- 18-
9- 19-
10- 20-

Rep Hinw Fig Item Rif	Numéro Teil-Nr Numero Part-Nr Part-Nr	Désignation Bezeichnung Descripcion Description Descrizione	Qté-Menge-Cant-Qty-Q.ta																			
			1	2	3	4	5	6	7	8	9	10	11	12	13	14	15	16	17	18	19	20
1	562472	Joint torique Junta tórica Anello OR - "0" ring - "0" ring -	1																			
2	550556	Cale d'épaisseur 0,15 mm Cala de espesor Spessore - Ausgleichscheibe - Shim -	X																			
2	550557	Cale d'épaisseur 0,20 mm Cala de espesor Spessore - Ausgleichscheibe - Shim -	X																			
2	551616	Cale d'épaisseur 0,40 mm Cala de espesor Spessore - Ausgleichscheibe - Shim -	X																			
2	552517	Cale d'épaisseur 0,50 mm Cala de espesor Spessore - Ausgleichscheibe - Shim -	X																			
3	603660	Couple conique Par conica Coppia conica - Kegelpaar - Bevel drive gear -	1																			
4	106550	Roulement Rodamiento Cuscinetto - Läger - Bearing -	2																			
5	562474	Ecrou Tuerca Dado - Mutter - Nut -	2																			
6	133186	Vis Tornillo Vite - Schraube - Screw -	4																			
7	748144	Vis Tornillo Vite - Schraube - Screw -	2																			
8	601243	Vis Tornillo Vite - Schraube - Screw -	12																			

+

Catalogue : 247290MOD

Qté-Menge-Cant-Qty-Q.ta

AX

1586

M

2

DIFFERENTIEL ESSIEU ARRIERE
HINTERACHSEDIFFERENTIAL
DIFERENCIAL EJE TRASERO
REAR AXLE DIFFERENTIAL
DIFFERENZIALE ASSALE POSTERIORE

1- 247290MOD 11-
2- 12-
3- 13-
4- 14-
5- 15-
6- 16-
7- 17-
8- 18-
9- 19-
10- 20-

Rep Hinw Fig Item Rif	Numéro Teil-Nr Numero Part-Nr Part-Nr	Désignation Bezeichnung Descripcion Description Descrizione	1 2 3 4 5 6 7 8 9 10 11 12 13 14 15 16 17 18 19 20																			
			1	2	3	4	5	6	7	8	9	10	11	12	13	14	15	16	17	18	19	20
9	562476	Rondelle Arandela Rondella - Unterlegscheibe - Washer -	2																			
10	562477	Planétaire Planetario Planetario - Ausgleichswellenrad - Planetary -	2																			
11	562478	Axe Eje Perno - Bolzen - Pin -	4																			
12	562479	Circlips Aro retén Anello elastico - Sicherungsring - Circlip -	4																			
13	562480	Rondelle Arandela Rondella - Unterlegscheibe - Washer -	4																			
14	562481	Satellite Satélite Satellite - Planetenrad - Planet wheel -	4																			
15	562482	Carter différentiel Cárter diferencial Scatola differenziale - Differentialgehäuse - Differential housing -	1																			
16	133069	Roulement Rodamiento Cuscinetto - Lager - Bearing -	2																			
17	474298	Cale d'épaisseur 0,20 mm Cala de espesor Spessore - Ausgleichscheibe - Shim -	X																			
17	474300	Cale d'épaisseur 0,30 mm Cala de espesor Spessore - Ausgleichscheibe - Shim -	X																			
17	551615	Cale d'épaisseur 0,15 mm Cala de espesor Spessore - Ausgleichscheibe - Shim -	X																			

+

Catalogue : 247290MOD

Qté-Menge-Cant-Qty-Q.ta

AX

1586

M

3

DIFFERENTIEL ESSIEU ARRIERE
HINTERACHSEDIFFERENTIAL
DIFERENCIAL EJE TRASERO
REAR AXLE DIFFERENTIAL
DIFFERENZIALE ASSALE POSTERIORE

1-	247290MOD	11-
2-		12-
3-		13-
4-		14-
5-		15-
6-		16-
7-		17-
8-		18-
9-		19-
10-		20-

Rep Hinw Fig Item Rif	Numéro Teil-Nr Numero Part-Nr Part-Nr	Désignation Bezeichnung Descripcion Description Descrizione	Qté-Menge-Cant-Qty-Q.ta																			
			1	2	3	4	5	6	7	8	9	10	11	12	13	14	15	16	17	18	19	20
17	552516	Cale d'épaisseur 0,10 mm Cala de espesor Spessore - Ausgleichscheibe - Shim -	X																			
18	562483	Entretoise Separador Distanziale - Querstrebe - Spacer -	1																			
19	133570	Ecrou Tuerca Dado - Mutter - Nut -	1																			
20	107293	Joint d'étanchéité Junta de estanqueidad Guarnizione - Dichtungsring - Seal -	1																			
21	107294	Tôle de protection Chapa de protección Lamiere di protezione - Schutzblech - Cover plate -	1																			
22	563904	Bride Flangia Flangia - Brida - Flange -	1																			
23	562485	Ecrou Tuerca Dado - Mutter - Nut -	1																			
24	562486	Circlips Aro retén Anello elastico - Sicherungsring - Circlip -	4																			
25	600552	Differential complet Diferencial completo Differenziale completo - Kompletter differential - Complete differential -	1																			
26	704684	Bride Flangia Flangia - Brida - Flange -	1																			
27	705645	Satellite Satélite Satellite - Planetenrad - Planet wheel -	4																			

+

Catalogue : 247290MOD

4

DIFFERENTIEL ESSIEU ARRIERE
 HINTERACHSEDIFFERENTIAL
 DIFERENCIAL EJE TRASERO
 REAR AXLE DIFFERENTIAL
 DIFFERENZIALE ASSALE POSTERIORE

Qté-Menge-Cant-Qty-Q.ta

AX

1586

M

1-	247290MOD	11-
2-		12-
3-		13-
4-		14-
5-		15-
6-		16-
7-		17-
8-		18-
9-		19-
10-		20-

Rep Hinw Fig Item Rif	Numéro Teil-Nr Numero Part-Nr Part-Nr	Désignation Bezeichnung Descripcion Description Descrizione	1	2	3	4	5	6	7	8	9	10	11	12	13	14	15	16	17	18	19	20	
28	705646	Axe Eje Perno - Bolzen - Pin -	4																				
29	747047	Différentiel complet Diferencial completo Differenziale completo - Kompletter differential - Complete differential -	1																				
30	748145	Joint d'étanchéité Junta de estanqueidad Guarnizione di tenuta - Dichtring - Seal -	1																				
31	749001	Vis Tornillo Vite - Schraube - Screw -	4																				

AX 1587

POUR ESSIEU ARRIERE
FÜR INTERACHSE
PARA EJE TRASERO
FOR REAR AXLE
PER ASSALE POSTERIORE

□ Type : **212 / 493**
□ Ref: **247 290**

REDUCTEUR ESSIEU ARRIERE
HINTERACHSE REDUKTIONSGETRIEBE
REDUCTOR EJE TRASERO
REAR AXLE REDUCTION GEAR
RIDUZIONE EPICICLODALE ASSALE POSTERIORE

M 40-4 ST3B
M 50-4 ST3B

M 40-4H ST3B
M 50-4H ST3B

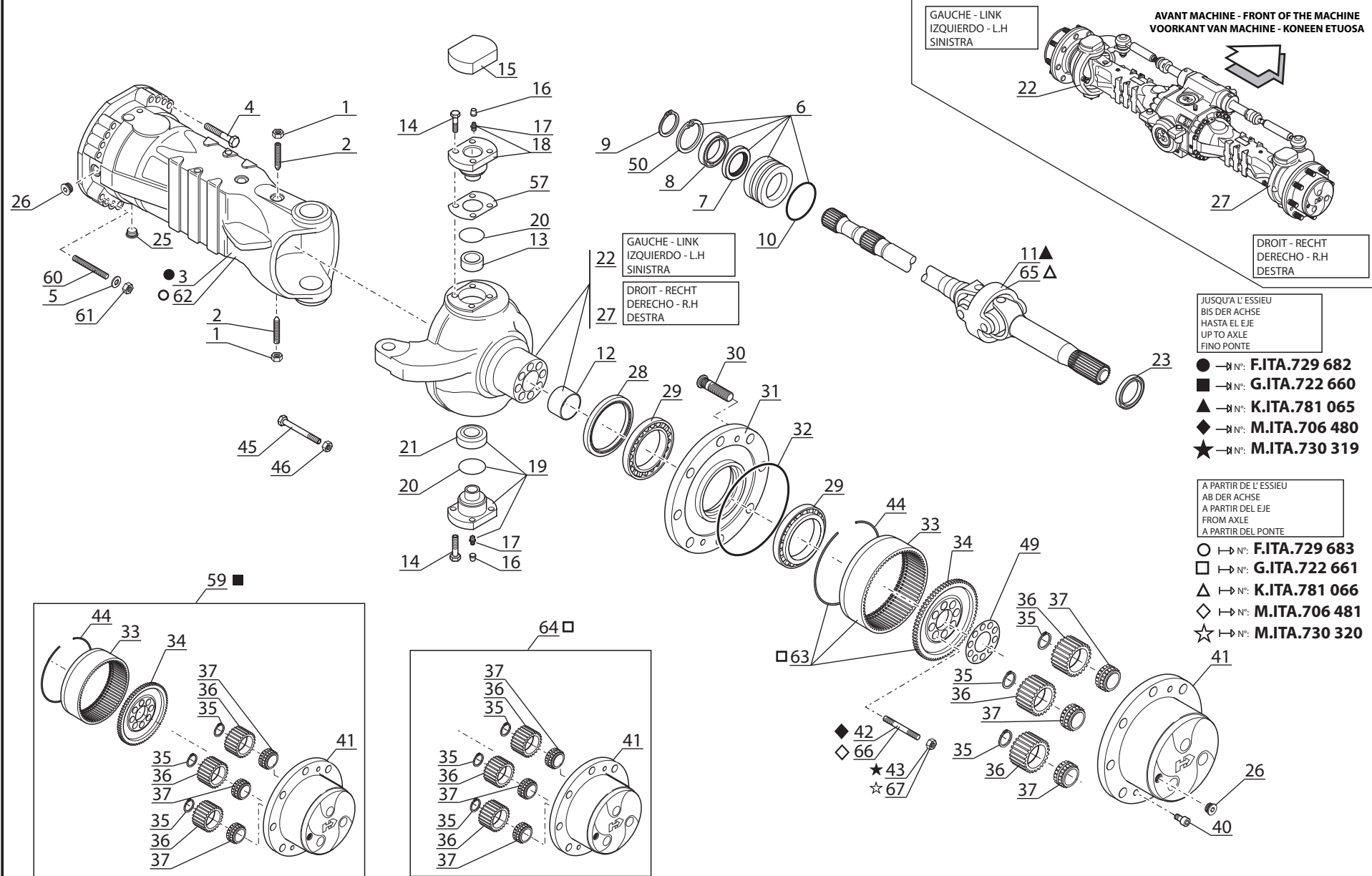

Catalogue : 247290MOD

Qté-Menge-Cant-Qty-Q.ta

AX

1587

M

1

REDUCTEUR ESSIEU ARRIERE
 HINTERACHSE REDUKTIONSGETRIEBE
 REDUCTOR EJE TRASERO
 REAR AXLE REDUCTION GEAR
 REDUZIONE EPICICLOIDALE ASSALE POSTERIORE

1-	247290MOD	11-
2-		12-
3-		13-
4-		14-
5-		15-
6-		16-
7-		17-
8-		18-
9-		19-
10-		20-

Rep Hinw Fig Item Rif	Numéro Teil-Nr Numero Part-Nr Part-Nr	Désignation Bezeichnung Descripcion Description Descrizione	Qté-Menge-Cant-Qty-Q.ta																			
			1	2	3	4	5	6	7	8	9	10	11	12	13	14	15	16	17	18	19	20
1	133090	Ecrou Tuerca Dado - Mutter - Nut -	2																			
2	562750	Pointeau Punzón Puntalino - Nadelventil - Needle valve -	2																			
3	603649	Carter latéral Cárter lateral Carter laterale - Seitlichgehäuse - Lateral axle case -	2																			
4	702138	Vis M16x100x 40 Tornillo Vite - Schraube - Screw -	28																			
5	562490	Rondelle Arandela Rondella - Unterlegscheibe - Washer -	4																			
6	563903	Bride Flangia Flangia - Brida - Flange -	2																			
7	108100	Joint d'étanchéité Junta de estanqueidad Guarnizióne - Dichtungsring - Seal -	2																			
8	105101	Roulement Rodamiento Cuscinetto - Läger - Bearing -	2																			
9	105424	Circlips Aro retén Anello elastico - Sicherungsring - Circlip -	2																			
10	562752	Joint torique Junta tórica Anello OR - "O" ring - "O" ring -	2																			
11	603650	Cardan Cardán Cardano - Kardan - Cardan -	2																			

+

Catalogue : 247290MOD

2

REDUCTEUR ESSIEU ARRIERE
 HINTERACHSE REDUKTIONSGETRIEBE
 REDUCTOR EJE TRASERO
 REAR AXLE REDUCTION GEAR
 REDUZIONE EPICICLOIDALE ASSALE POSTERIORE

Qté-Menge-Cant-Qty-Q.ta

AX

1587

M

1-	247290MOD	11-
2-		12-
3-		13-
4-		14-
5-		15-
6-		16-
7-		17-
8-		18-
9-		19-
10-		20-

Rep Hinw Fig Item Rif	Numéro Teil-Nr Numero Part-Nr Part-Nr	Désignation Bezeichnung Description Descrizione	Qté-Menge-Cant-Qty-Q.ta																			
			1	2	3	4	5	6	7	8	9	10	11	12	13	14	15	16	17	18	19	20
12	477847	Bague Anillo Anello - BÜchse - Bushing -	2																			
13	603651	Bague Anillo Anello - BÜchse - Bushing -	2																			
14	562475	Vis Tornillo Vite - Schraube - Screw -	20																			
15	600559	Couvercle Tapadera Coperchio - Deckel - Cover -	2																			
16	107796	Bouchon Tapón Tappo - Stopfen - Plug -	4																			
17	133103	Graisser Engrasador Ingrassatore - Schmiernippel - Greaser -	4																			
18	564903	Pivot de direction Pivote de dirección Perno di sterzo - Lenkung zapfen - Pivot pin -	2																			
19	564898	Pivot de direction Pivote de dirección Perno di sterzo - Lenkung zapfen - Pivot pin -	2																			
20	562499	Joint d'étanchéité Junta de estanqueidad Guarnizione - Dichtungsring - Seal -	4																			
21	562500	Bague Anillo Anello - BÜchse - Bushing -	2																			
22	604256	Boîtier de direction Cárter de dirección Scatola di sterzo - Lenkungsgehäuse - Steering case -	1																			

+

Catalogue : 247290MOD

3

REDUCTEUR ESSIEU ARRIERE
 HINTERACHSE REDUKTIONSGETRIEBE
 REDUCTOR EJE TRASERO
 REAR AXLE REDUCTION GEAR
 REDUZIONE EPICICLOIDALE ASSALE POSTERIORE

Qté-Menge-Cant-Qty-Q.ta

AX

1587

M

1-	247290MOD	11-
2-		12-
3-		13-
4-		14-
5-		15-
6-		16-
7-		17-
8-		18-
9-		19-
10-		20-

Rep Hinw Fig Item Rif	Numéro Teil-Nr Numero Part-Nr Part-Nr	Désignation Bezeichnung Descripcion Description Descrizione	Qté-Menge-Cant-Qty-Q.ta																			
			1	2	3	4	5	6	7	8	9	10	11	12	13	14	15	16	17	18	19	20
23	603653	Joint d'étanchéité Junta de estanqueidad Guarnizione di tenuta	- Dichtungsring - Seal -	2																		
25	702418	Bouchon magnétique Tapón magnetico Tappo magnetico	- Magnetischstopfen - Magnetic plug -	2																		
26	603638	Bouchon Tapón Tappo	- Stopfen - Plug -	4																		
27	604257	Boîtier de direction Cárter de dirección Scatola di sterzo	- Lenkungsgehäuse - Steering case -	1																		
28	604656	Joint d'étanchéité Junta de estanqueidad Guarnizione di tenuta	- Dichtungsring - Seal -	2																		
29	562504	Roulement Rodamiento Cuscinetto	- Lager - Bearing -	4																		
30	702778	Goujon de roue Espárrago de rueda Prigioniero di ruota	- Stiftschraube - Wheel stud -	16																		
31	601246	Moyeu de roue Cubo de rueda Mozzo ruota	- Radnabe - Wheel hub -	2																		
32	106533	Joint torique Junta tórica Anello OR	- "O" ring - "O" ring -	2																		
33	564133	Couronne dentée (70 dents) Corona dentada Corona dentata	- Zahnkranz - Gear ring -	2																		
34	565998	Support porte couronne Soporte portacorona Supporto porta corona	- Zahnkranz träger - Ring gear bracket -	2																		

+

Catalogue : 247290MOD

4

REDUCTEUR ESSIEU ARRIERE
 HINTERACHSE REDUKTIONSGETRIEBE
 REDUCTOR EJE TRASERO
 REAR AXLE REDUCTION GEAR
 REDUZIONE EPICICLOIDALE ASSALE POSTERIORE

Qté-Menge-Cant-Qty-Q.ta

AX

1587

M

1-	247290MOD	11-
2-		12-
3-		13-
4-		14-
5-		15-
6-		16-
7-		17-
8-		18-
9-		19-
10-		20-

Rep Hinw Fig Item Rif	Numéro Teil-Nr Numero Part-Nr Part-Nr	Désignation Bezeichnung Descripcion Description Descrizione	1	2	3	4	5	6	7	8	9	10	11	12	13	14	15	16	17	18	19	20
35	562508	Circlips Aro retén Anello elastico - Sicherungsring - Circlip -	6																			
36	562509	Satellite (27 dents) Satélite Satellite - Planetenrad - Planet wheel -	6																			
37	562510	Roulement Rodamiento Cuscinetto - Läger - Bearing -	6																			
40	600670	Vis Tornillo Vite - Schraube - Screw -	4																			
41	604252	Support satellites Soporte satélite Supporto satelliti - Planetenrad träger - Planet wheel bracket -	2																			
42	562512	Goujon Espárrago Prigioniero - Stiftschraube - Stud-bolt -	16																			
43	562513	Ecrou Tuerca Dado - Mutter - Nut -	16																			
44	562514	Circlips Aro retén Anello elastico - Sicherungsring - Circlip -	2																			
45	602219	Vis de réglage Tornillo de regulación Vite di regolaggio - Stellschraube - Adjusting screw -	4																			
46	474313	Ecrou Tuerca Dado - Mutter - Nut -	4																			
49	562515	Tôle de sécurité Chapa de seguridad Lamiera di sicurezza - Sicherungsblech - Locking plate -	2																			

+

Catalogue : 247290MOD

5

REDUCTEUR ESSIEU ARRIERE
 HINTERACHSE REDUKTIONSGETRIEBE
 REDUCTOR EJE TRASERO
 REAR AXLE REDUCTION GEAR
 REDUZIONE EPICICLOIDALE ASSALE POSTERIORE

Qté-Menge-Cant-Qty-Q.ta

AX

1587

M

1-	247290MOD	11-
2-		12-
3-		13-
4-		14-
5-		15-
6-		16-
7-		17-
8-		18-
9-		19-
10-		20-

Rep Hinw Fig Item Rif	Numéro Teil-Nr Numero Part-Nr Part-Nr	Désignation Bezeichnung Descripcion Description Descrizione	Qté-Menge-Cant-Qty-Q.ta																			
			1	2	3	4	5	6	7	8	9	10	11	12	13	14	15	16	17	18	19	20
50	133044	Circlips Aro retén Anello elastico	- Sicherungsring - Circlip -	2																		
57	564679	Cale d'épaisseur 0,15 mm Cala de espesor Spessore	- Ausgleichscheibe - Shim -	X																		
57	564680	Cale d'épaisseur 0,20 mm Cala de espesor Spessore	- Ausgleichscheibe - Shim -	X																		
57	564681	Cale d'épaisseur 0,50 mm Cala de espesor Spessore	- Ausgleichscheibe - Shim -	X																		
59	603723	Support satellites Soporte satélite Supporto satelliti	- Planetenträger - Planet wheel bracket -	1																		
60	603655	Goujon Espárrago Prigioniero	- Stiftschraube - Stud-bolt -	4																		
61	602275	Ecrou Tuerca Dado	- Mutter - Nut -	4																		
62	706961	Carter latéral Cárter lateral Carter laterale	- Seitlichgehäuse - Lateral axle case -	1																		
63	706355	Support porte couronne Soporte portacorona Supporto porta corona	- Zahnkranz träger - Ring gear bracket -	1																		
64	706962	Kit support satellites Kit soporte satélite Kit supporto satelliti	- Planetenrad träger kit - Planet wheel bracket kit -	1																		
65	787988	Cardan Cardán Cardano	- Kardan - Cardan -	2																		

+

Catalogue : 247290MOD

6

REDUCTEUR ESSIEU ARRIERE
 HINTERACHSE REDUKTIONSGETRIEBE
 REDUCTOR EJE TRASERO
 REAR AXLE REDUCTION GEAR
 REDUZIONE EPICICLOIDALE ASSALE POSTERIORE

Qté-Menge-Cant-Qty-Q.ta

AX

1587

M

1-	247290MOD	11-
2-		12-
3-		13-
4-		14-
5-		15-
6-		16-
7-		17-
8-		18-
9-		19-
10-		20-

Rep Hinw Fig Item Rif	Numéro Teil-Nr Numero Part-Nr Part-Nr	Désignation Bezeichnung Descripcion Description Descrizione
66	749982	Goujon - Stiftschraube Espárrago - Stud-bolt Prigioniero -
67	750337	Ecrou - Mutter Tuerca - Nut Dado -

1	2	3	4	5	6	7	8	9	10	11	12	13	14	15	16	17	18	19	20	
16																				
16																				

AX 1588

POUR ESSIEU ARRIERE
 FÜR INTERACHSE
 PARA EJE TRASERO
 FOR REAR AXLE
 PER ASSALE POSTERIORE

□ Type : **212 / 493**
 □ Ref: **247 290**

SYSTEME DE DIRECTION ESSIEU ARRIERE
 HINTERACHSE LENKSYSTEM
 SISTEMA DE DIRECCION EJE TRASERO
 REAR AXLE STEERING SYSTEM
 SISTEMA DI STERZO ASSALE POSTERIORE

M 40-4 ST3B
M 50-4 ST3B

M 40-4H ST3B
M 50-4H ST3B

GAUCHE - LINK
 IZQUIERDO - L.H
 SINISTRA

■ 6
 □ 10

GAUCHE - LINK
 IZQUIERDO - L.H
 SINISTRA

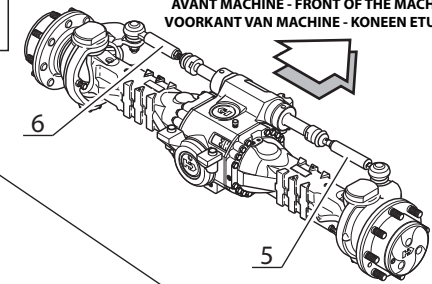

AVANT MACHINE - FRONT OF THE MACHINE
 VOORKANT VAN MACHINE - KONEEN ETUOSA

DROIT - RECHT
 DERECHO - R.H
 DESTRA

POCHETTE DE JOINTS
 DICHTUNGSATZ
 JUEGO DE JUNTAS
 SEAL KIT
 SERIE GUARNIZIONE

1 ●
 8 ○

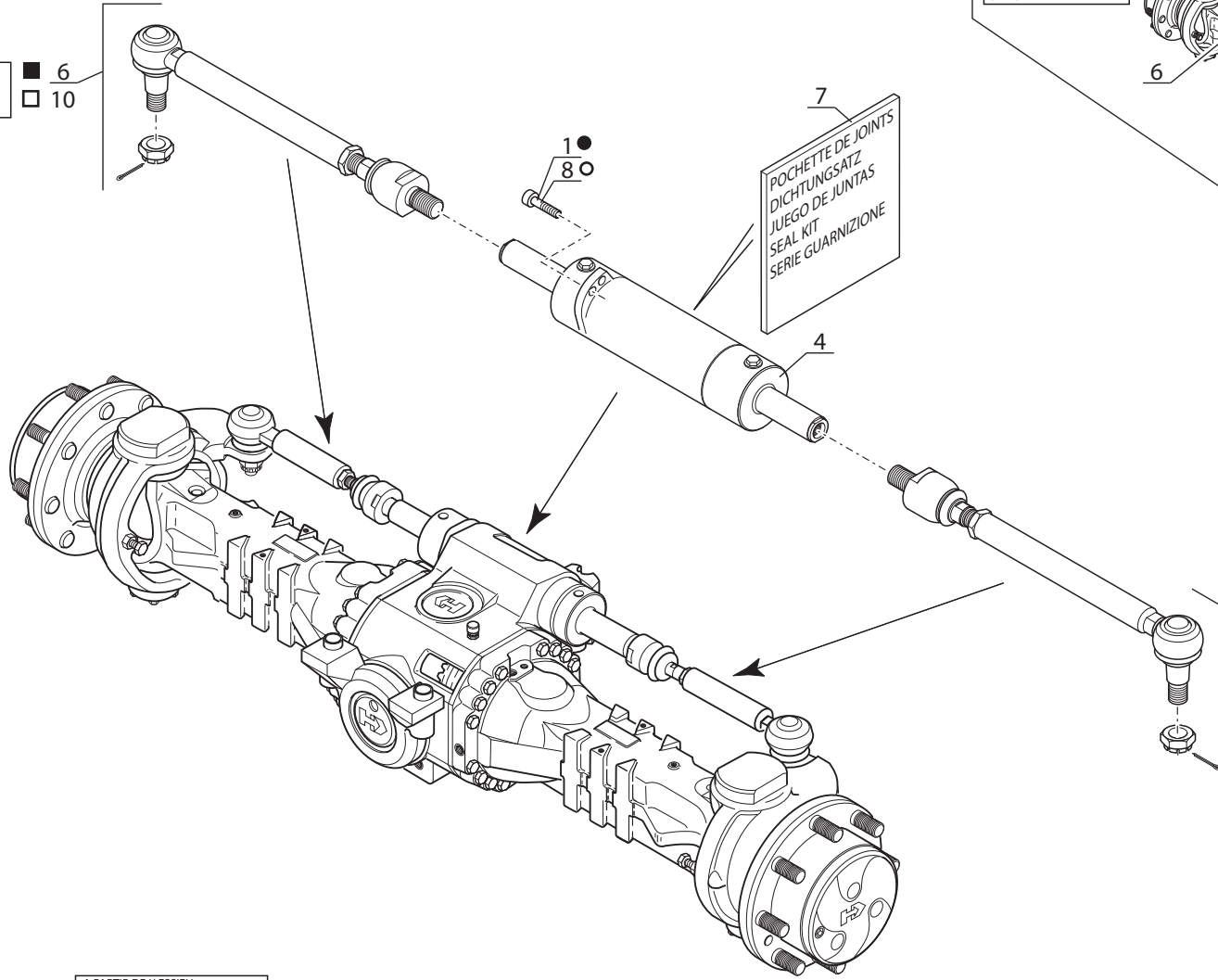

5 ■ DROIT - RECHT
 DERECHO - R.H
 9 □ DESTRA

JUSQU'A L' ESSIEU
 BIS DER ACHSE
 HASTA EL EJE
 UP TO AXLE
 FINO PONTE

● → N°: **K.ITA.757 396**
 ■ → N°: **P.ITA.709 627**

A PARTIR DE L' ESSIEU
 AB DER ACHSE
 A PARTIR DEL EJE
 FROM AXLE
 A PARTIR DEL PONTE

○ → N°: **K.ITA.757 397**
 □ → N°: **P.ITA.709 628**

Catalogue : 247290MOD

Qté-Menge-Cant-Qty-Q.ta

AX

1588

M

1
 SYSTEME DE DIRECTION ESSIEU ARRIERE
 HINTERACHSE LENKSYSTEM
 SISTEMA DE DIRECCION EJE TRASERO
 REAR AXLE STEERING SYSTEM
 SISTEMA DI STERZO ASSALE POSTERIORE

1-	247290MOD	11-
2-		12-
3-		13-
4-		14-
5-		15-
6-		16-
7-		17-
8-		18-
9-		19-
10-		20-

Rep Hinw Fig Item Rif	Numéro Teil-Nr Numero Part-Nr Part-Nr	Désignation Bezeichnung Descripcion Description Descrizione
-----------------------------------	---	---

1	2	3	4	5	6	7	8	9	10	11	12	13	14	15	16	17	18	19	20
---	---	---	---	---	---	---	---	---	----	----	----	----	----	----	----	----	----	----	----

1	562526	Vis Tornillo Vite - Schraube - Screw -
4	702067	Vérin de direction Cilindro de direccion Cilindro di sterzo - Lenkzylinder - Steering cylinder -
5	603657	Barre d'accouplement articulée- Barra acoplamiento articulada - Barra de accoppiamento - Gelenkte Spurstange Linked tie-rod -
6	603657	Barre d'accouplement articulée- Barra acoplamiento articulada - Barra de accoppiamento - Gelenkte Spurstange Linked tie-rod -
7	702147	Pochette de joints Juego de juntas Kit guarnizióni - Dichtungssatz - Seal kit -
8	748435	Vis Tornillo Vite - Schraube - Screw -
9	894466	Barre d'accouplement Barra de acoplamiento Barra de accoppiamento - Spurstange - Cross rod -
10	894466	Barre d'accouplement Barra de acoplamiento Barra de accoppiamento - Spurstange - Cross rod -

4																			
1																			
1																			
1																			
1																			
4																			
1																			
1																			

AX 1589

POUR ESSIEU ARRIERE
FÜR INTERACHSE
PARA EJE TRASERO
FOR REAR AXLE
PER ASSALE POSTERIORE

Type : **212 / 493**

Ref: **247 290**

SUPPORT ESSIEU ARRIERE
HINTERACHSE TRÄGER
SOPORTE EJE TRASERO
REAR AXLE BRACKET
SUPPORTO ASSALE POSTERIORE

M 40-4 ST3B
M 50-4 ST3B

M 40-4H ST3B
M 50-4H ST3B

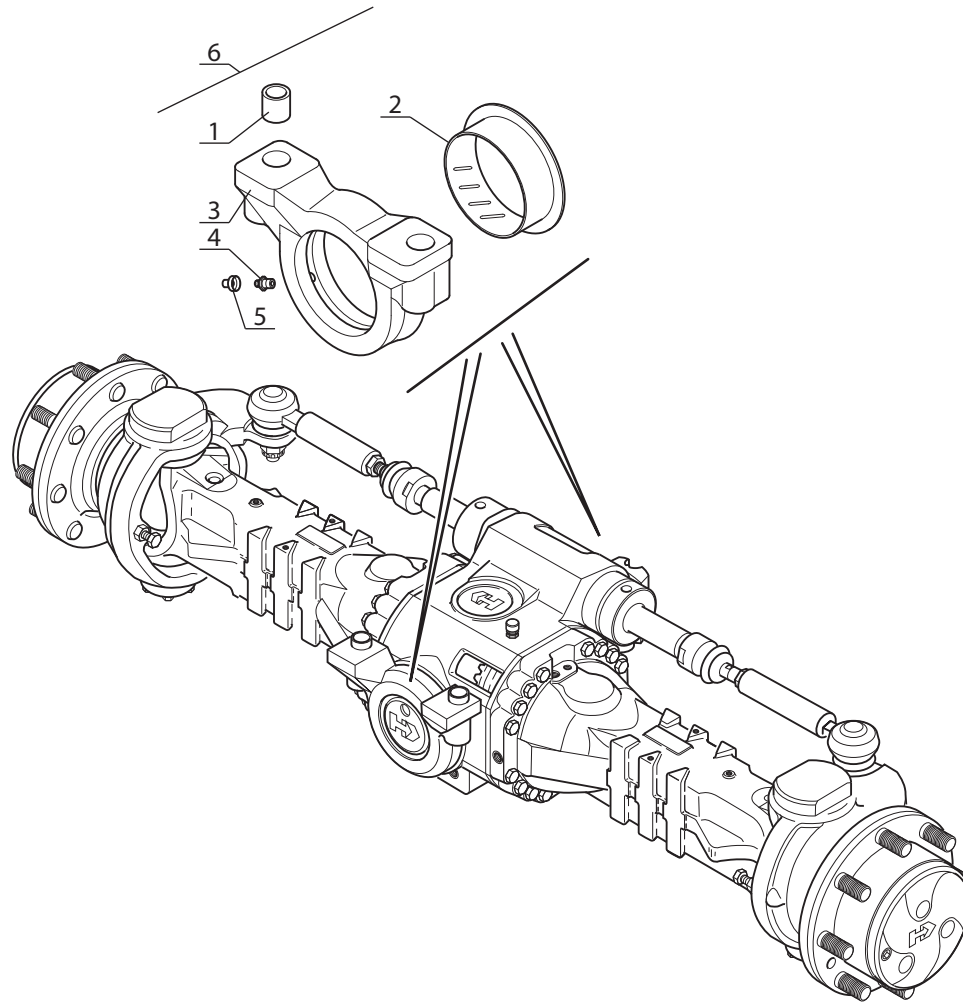

Catalogue : 247290MOD

Qté-Menge-Cant-Qty-Q.ta

AX

1589

M

1

SUPPORT ESSIEU ARRIERE
HINTERACHSE TRAGER
SOPORTE EJE TRASERO
REAR AXLE BRACKET
SUPPORTO PONTE POSTERIORE

1- 247290MOD 11-
2- 12-
3- 13-
4- 14-
5- 15-
6- 16-
7- 17-
8- 18-
9- 19-
10- 20-

Rep Hinw Fig Item Rif	Numéro Teil-Nr Numero Part-Nr Part-Nr	Désignation Bezeichnung Descripcion Description Descrizione	Qté-Menge-Cant-Qty-Q.ta																			
			1	2	3	4	5	6	7	8	9	10	11	12	13	14	15	16	17	18	19	20
1	477964	Manchon Manguito Manicotto	- Muffe - Coupling -	4																		
2	477538	Bague Anillo Anello	- Büchse - Bushing -	2																		
3	564693	Support essieu Soporte eje Supporto assale	- Achse träger - Axle bracket -	2																		
4	133103	Graisneur Engrasador Ingrassatore	- Schmiernippel - Greaser -	2																		
5	107796	Bouchon Tapón Tappo	- Stopfen - Plug -	2																		
6	601561	Support essieu Soporte eje Supporto assale	- Achse träger - Axle bracket -	2																		