



MANITOU NORTH AMERICA, INC.

6401 IMPERIAL DRIVE
Waco, TX 76712-6803

M30/40/50/60-2 H/L
M30/40/50/60-4 H/L

**HYDROSTATIC & 4-SPEED
TRANSMISSIONS
- TIER I ENGINE -**

PARTS MANUAL

S/N: 181964 thru 750818 (except 750503)
(including 170493 & 170514)

For Parts Orders contact your Manitou North America Dealer or call:
Manitou North America, Parts Dept. 800-425-3727 or (254) 799-0232
Parts Dept. Fax: (254) 867-6504 Website: www.manitou-na.com

M-SERIES

FORKLIFT MODEL DESCRIPTION

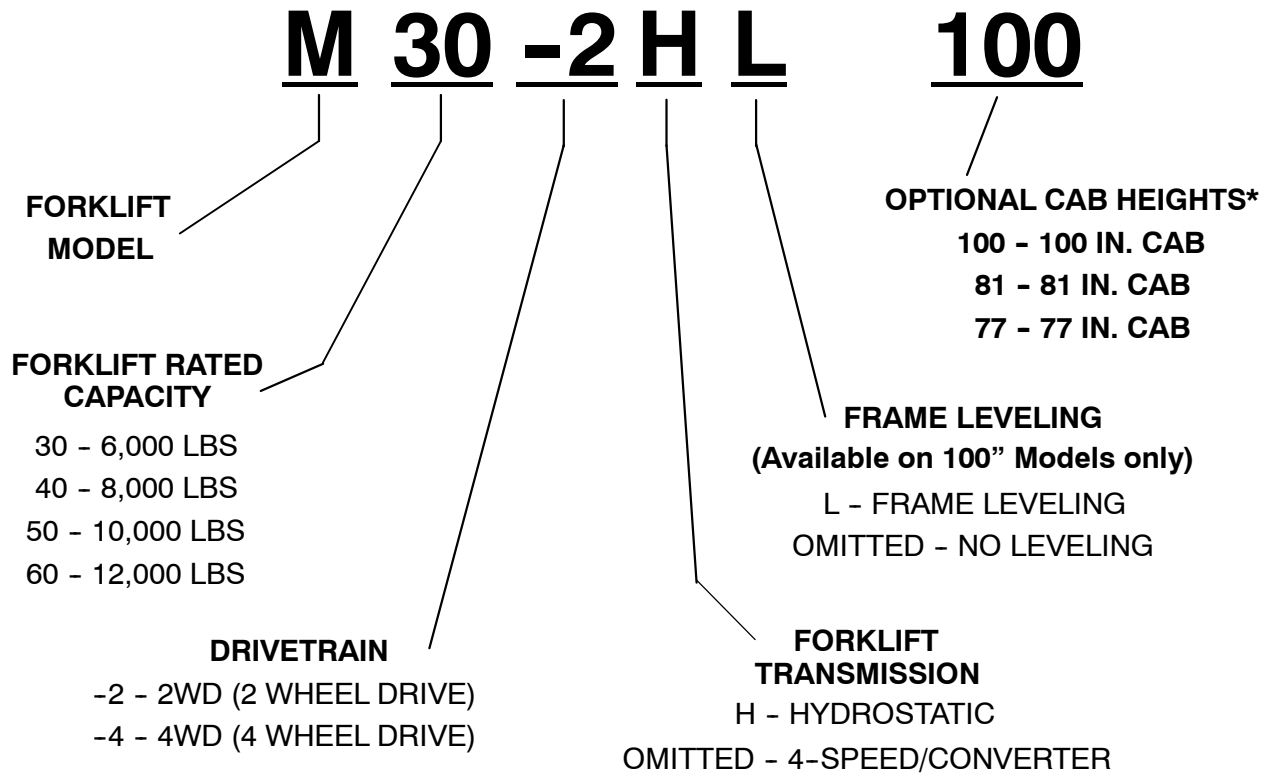

* Dimensions may vary depending on tires, additional options, etc.

M-SERIES POWERTRAIN COMPONENT IDENTIFICATION

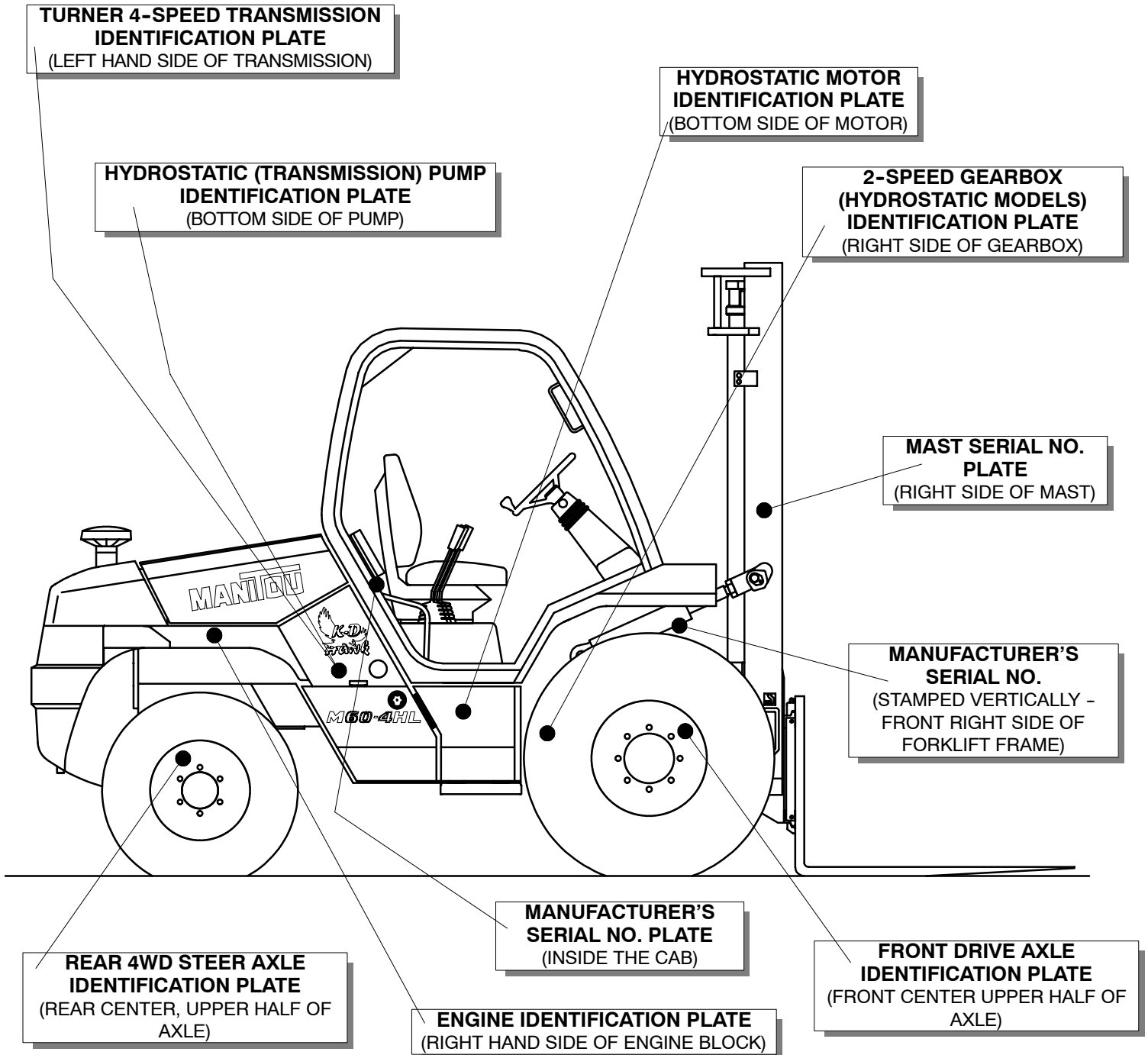

GENERAL INFORMATION

The purpose of this catalog is to provide illustrations for identifying and ordering assorted forklift parts. The illustrations provide a general description and may not show the *exact* shape or detail of the parts or components represented.

The parts are identified by an Item number on the Illustration Page. Find the Item Number for the part desired, then locate that Item Number under the "Items" column on the parts page. The part number will be located directly to the right of the Item Number. Also provided is a part description, dimensions (where necessary), quantity of parts required and the Truck Model Identification.

Manitou North America, Inc. continues to improve product design as new technologies are developed, and reserves the right to make revisions without prior notice. Please contact your nearest dealer or the Manitou North America Parts Dept. if you have any questions.

When ordering parts or requesting technical information, the following numbers are required:

Truck Model No: _____

Serial No: _____

Mast Model No: _____

Serial No: _____

Engine Name (Cat or Perkins): _____

Engine (List) No: _____

Transmission (Hydrostatic or 4-Speed): _____

Model (MANITOU) reference: _____

Serial No: _____

Hydrostatic (Hydrostatic Models only) Motor: _____

Model No: _____

Serial No: _____

Gearbox (Hydrostatic Models only) Model No: _____

Serial No: _____

Front Drive Axle No: _____

MANITOU reference: _____

Serial No: _____

Rear Drive Axle (4WD) No: _____

MANITOU reference: _____

Serial No: _____

Attachment Model No: _____

Serial No: _____

For quick reference it is recommended these numbers be recorded as soon as possible.

ALPHABETICAL CONTENTS

CATALOG 802832, R03-04

Description, (Drawing No.), Assembly Ref. No.

ACCELERATOR PEDAL ASSEMBLY, 100 IN. CAB ONLY, (27), 6BB11	ELECTRICAL SWITCHES, SWITCH BOXES, BULBS, ETC., (72.01), 11CC09
ACCELERATOR PEDAL ASSEMBLY, 77 & 81 IN. CAB, (28.01), 6BB21	ELECTRICAL, OVERHEAD WORK LIGHTS, (69), 11BA10
AIR INTAKE SYSTEM, INSTALLATION, (3), 4AA10	ELECTRICAL, POULTRY/BACK DOCK LIGHTING OPTION, (71), 11BA30
ALTERNATOR INSTALLATION, PERKINS, (88), AP1437	ELECTRICAL, ROAD LIGHTING OPTION, (70), 11BA20
BRAKE SYSTEM ASSEMBLY, HYDRAULIC, 100 IN. CAB ONLY, (26), 6BB10	ELECTRICAL, WARNING BEACON OPTION, (72), 11BA40
BRAKE SYSTEM ASSEMBLY, HYDRAULIC, 77 & 81 IN. CAB, (28), 6BB20	ENGINE CONVERSION KIT, TO TIER 2, (88.10), TIER 2
CAB ASSEMBLY, 100 IN. FULLY ENCLOSED, (32), 8AA10	ENGINE COVER AND COUNTERWEIGHT COVER, (60), 9AA11
CAB ASSEMBLY, 100 IN. OPEN, (42), 8AA30	ENGINE MOUNTING, (7), 4AA40
CAB ASSEMBLY, 100 IN. SEMI-ENCLOSED, (38), 8AA20	ENGINE SHUTDOWN KIT, (78), 11CD10
CAB ASSEMBLY, 77 & 81 IN. 4-SPEED, (43), 8AA40	ENGINE, COMPLETE, (82), AP2054
CAB ASSEMBLY, 77 & 81 IN. HYDROSTATIC, (44), 8AA50	EXHAUST SYSTEM ASSEMBLY, (4), 4AA20
CAB DETAILS 1, 100 IN. FULLY ENCLOSED, (33), 8AA11	FILTER ASSEMBLIES, HYDRAULIC TANK, (62.02), 10AA40
CAB DETAILS 1, 100 IN. SEMI-ENCLOSED, (39), 8AA21	FILTERS AND BELTS, (1), 2AA79A
CAB DETAILS 2, 100 IN. FULLY ENCLOSED, (34), 8AA12	FRAME AND COUNTERWEIGHTS, (16), 6AA10
CAB DETAILS 2, 100 IN. SEMI-ENCLOSED, (40), 8AA22	FRONT DRIVE AXLE AND DRIVESHAFT INSTALLATION (EXCEPT FRAME LEVELING), (18.00), 6AA20
CAB DETAILS 3, 100 IN. FULLY ENCLOSED, (34.01), 8AA13	FRONT DRIVE AXLE AND DRIVESHAFT INSTALLATION (FRAME LEVELING), (20), 6AA30
CAB DETAILS 3, 100 IN. SEMI-ENCLOSED, (41), 8AA23	FRONT DRIVE AXLE PRE-INSTALLATION (FRAME LEVELING ONLY), (21), 6AA31
CAB DETAILS 4, 100 IN. FULLY ENCLOSED, (35), 8AA14	FRONT FENDER EXTENSIONS, 100 IN. CAB, (55), 8AA121
CAB DETAILS 5, 100 IN. FULLY ENCLOSED, (36), 8AA15	FRONT FENDERS, 100 IN. CAB, (54), 8AA120
CAB DETAILS 6, 100 IN. FULLY ENCLOSED, (37), 8AA16	FRONT FENDERS, 81 & 77 IN. CABS, (56), 8AA122
CAB MOUNTING ASSEMBLY, (45), 8AA100	FUEL TANK AND LIFT PUMP INSTALLATION, (15), 4AC11
CAB WIRING HARNESS, 77, 81, & 100 IN. (OPEN CABS ONLY), (73), 11CC10	FUEL TANK ASSEMBLY, (14), 4AC10
CYLINDER, FRAME LEVELING, INSTALLATION, (22), 6AA32	GAUGES, OIL TEMP, OIL PRESS, WATER TEMP, (77), 11CC14
DECALS, (81), 12AA10	GEAR LEVER ASSEMBLY, 4-SPEED TRANSMISSION, 2WD & 4WD, (9), 4AA51
DRIVE AXLE OIL COOLER I (TORQUE CONVERTER OPTION), (79.50), 11CD30	GEARBOX, 2-SPEED REDUCTION, (90), AX1225
DRIVE AXLE OIL COOLER II (TORQUE CONVERTER OPTION), (79.51), 11CD31	HEATER, SEMI AND OPEN CAB, (68.50), 11AB10
DRIVE AXLE, FRONT, (91), AX2519A	HYDRAULIC DIFFERENTIAL LOCKING ASSEMBLY, (64), 10AF10
DRIVE AXLE, FRONT, CASING, (92), AX1412	HYDRAULIC SYSTEM, PUMP AND CONTROLS, (63), 10AE10
DRIVE AXLE, FRONT, DIFFERENTIAL, (93), AX1449	HYDRAULIC TANK ASSEMBLY, 4-SPEED TRANSMISSION, (61), 10AA10
DRIVE AXLE, FRONT, DISC BRAKES, (95), AX1415	HYDRAULIC TANK ASSEMBLY, HYDROSTATIC TRANSMISSION, (62), 10AA20
DRIVE AXLE, FRONT, REDUCTION GEAR, (94), AX1450	HYDRAULIC VALVE BANK ASSEMBLY, (66), 10DA88
ELECTRICAL ASSEMBLY (BREAKERS), 4-SPEED, (67.01), 11AA11	HYDROSTATIC (TRANSMISSION) ANTI-FOAM FIELD INSTALLATION, (10.50), 4AB10.5
ELECTRICAL ASSEMBLY (FUSES), 4-SPEED, (67), 11AA10	HYDROSTATIC (TRANSMISSION) SYSTEM ASSEMBLY, 1ST MOUNTING, (10), 4AB10
ELECTRICAL ASSEMBLY (BREAKERS), HYDROSTATIC, (68.01), 11AA21	HYDROSTATIC (TRANSMISSION) SYSTEM ASSEMBLY, 2ND MOUNTING, (10.10), 4AB10.1
ELECTRICAL ASSEMBLY (FUSES), HYDROSTATIC, (68), 11AA20	

ALPHABETICAL CONTENTS

CATALOG 802832, R03-04

Description, (Drawing No.), Assembly Ref. No.

HYDROSTATIC (TRANSMISSION) SYSTEM ASSEMBLY, 3RD MOUNTING, (10.20), 4AB10.2	STEERING COLUMN ASSEMBLY, 100 IN. SEMI & FULLY ENCLOSED CAB, (46), 8AA101
HYDROSTATIC COUPLING, (11), 4AB10A	STEERING COLUMN ASSEMBLY, 100 IN. OPEN CAB, (47), 8AA102
HYDROSTATIC GEARBOX HYDRAULICS, (13), 4AB12	STEERING COLUMN ASSEMBLY, 81 & 77 IN. CAB, (48), 8AA103
HYDROSTATIC INCHING VALVE, TH7, (13), 4AB12	STEERING COLUMN ASSEMBLY, TILTING, 100 IN. SEMI & ENCLOSED CAB, (48.01), 8AA104
HYDROSTATIC GEARBOX SOLENOID HARNESS, (79), 11CD20	STEERING COLUMN ASSEMBLY, TILTING, 100 IN. OPEN CAB, (49), 8AA105
HYDROSTATIC MOTOR, (102), BC108	STEERING COLUMN ASSEMBLY, TILTING, 81 & 77 IN. OPEN CAB, (50), 8AA106
HYDROSTATIC SYSTEM ASSEMBLY, (12), 4AB11	STEERING CYLINDER, 2WD, (65.01), 10CE15
MAST MOUNTING HARDWARE, (15.50), 5AA10	STEERING CYLINDER, 4WD STEER AXLE, (100), AX1419
MAST TILT AND SIDE-SHIFT CYLINDER ASSEMBLY, (63.01), 10AE11	STEERING HYDRAULICS, 2WD AND 4WD, (65), 10BA10
OIL COOLER, HYDROSTATIC, POULTRY, OPTIONAL, (62.01), 10AA30	TACHOMETER OPTION, (76), 11CC13
OIL FILTER BRACKET, PERKINS, (85), AP1434	TIRES AND WHEELS, FRONT, (2.01), 3AA10
PARKING BRAKE ASSEMBLY, EXCEPT 100 IN. SEMI & ENCLOSED CABS, (24), 6BA20	TIRES AND WHEELS, REAR, (2.02), 3AA20
PARKING BRAKE ASSEMBLY, 100 IN. SEMI & ENCLOSED CABS, (23), 6BA10	TRANSMISSION INSTALLATION, 4-SPEED (2WD & 4WD), (8), 4AA50
PARKING BRAKE LEVER, 100 IN. SEMI AND ENCLOSED CABS, (25), 6BA54	TRANSMISSION, 4-SPEED, 2WD, (104), BP177
RADIATOR COOLING TRAY, (6), 4AA31	TRANSMISSION, 4-SPEED, 2WD, CONTROL VALVE, (107), BP180
RADIATOR INSTALLATION, (5), 4AA30	TRANSMISSION, 4-SPEED, 2WD, EXTERNAL COMPONENTS, (105), BP 178
SEAT ASSEMBLY, 100 IN. CAB, (51), 8AA110	TRANSMISSION, 4-SPEED, 2WD, INTERNAL COMPONENTS, (106), BP179
SEAT ASSEMBLY, HIGH BACK, 77 & 81 IN. CAB, (53), 8AA112	TRANSMISSION, 4-SPEED, 4WD, (108), BP181
SEAT ASSEMBLY, LOW BACK, 77 & 81 IN. CAB, (52), 8AA111	TRANSMISSION, 4-SPEED, 4WD, CONTROL VALVE, (111), BP184
SENSORS, ENGINE (PERKINS) AND TRANSMISSION (4-SPEED, 2WD/4WD), (80), 11CD58	TRANSMISSION, 4-SPEED, 4WD, EXTERNAL COMPONENTS, (109), BP 182
SIDE PANELS, REAR FENDERS, AND HOOD LIFT CYLINDER, (59), 9AA10	TRANSMISSION, 4-SPEED, 4WD, INTERNAL COMPONENTS, (110), BP183
SIDE STEP INSTALLATION, (17), 6AA11	TRANSMISSION, HYDROSTATIC PUMP, (103), BC139
STARTER MOTOR, PERKINS, (83), AP1430	VALVE COVER AND BREATHER, PERKINS, (84), AP1432
STEER AXLE CASING, 4WD, (97), AX1416	WATER OUTLET CONNECTIONS, PERKINS, (87), AP1436
STEER AXLE DIFFERENTIAL, 4WD, (98), AX1417	WATER PUMP, PERKINS, (86), AP1435
STEER AXLE REDUCTION GEAR, 4WD, (99), AX1418	WINDSHIELD KIT, 100 IN. OPEN CAB (CAB 802656), (57), 8AA123
STEER AXLE SUPPORT BRACKET, 4WD, (101), AX1420	WINDSHIELD KIT, 77 AND 81 IN. OPEN CAB (HYDROSTATIC OR 4-SPEED), (58), 8AA124
STEER AXLE, 2WD, (30), 7AA11	WINDSHIELD WIPER INSTALLATION, 100 IN. CAB (CAB 802656), (74), 11CC11
STEER AXLE, 4WD, (96), AX2520	WINDSHIELD WIPER INSTALLATION, 77 & 81 IN. CAB, (75), 11CC12
STEERING AXLE AND DRIVESHAFT INSTALLATION, 4WD, (31), 7AB10	
STEERING AXLE AND HANGER INSTALLATION, 2WD, (29), 7AA10	

2 AA 79A

128982 Perkins fuel filter, glass w/ hardware
132795 Engine oil filter
601749 Transmission oil filter (4-speed transmission)
464171* Cat Engine fuel filter (Caterpillar, no glass bowl)
431206P Perkins Engine fuel filter (propylene glass bowl, not included)
321174 (4-4000) Hydraulic return oil filter
802086 (hydraulic) Hydraulic return oil filter
430001 Filter cap for hydraulic oil tank
474048 Fan belt alternator Side TOSSER & BELOW
466716 Fan belt alternator Side TOSSER & ABOVE
802185 Cap vent filter (700 in. enclosed only)
803072 Air intake Pre-filter
803073 Fan Cap Pre-filter
847794 Suction strainer (holds hydraulic oil tank)
150848 Turbo I
* The Cat Mark

1.00

3 AA 10

TREAD TREAD 8000R
TREAD TREAD 8000R
TREAD TREAD 8000R
800D YEAR TREAD 8000R
MICHELIN TREAD 8000R
MICHELIN TREAD 8000R
MICHELIN TREAD 8000R
MICHELIN TREAD 8000R

2.01

3 AA 20

CYR TREAD 8000R (2PK)
CYR TREAD 8000R (2PK)
CYR TREAD 8000R (2PK)
MICHELIN TREAD 8000R (2PK)

2.02

4 AA 10

VELOCAR CL. JAMER (STEEL HOUSING) - POLYMER ONLY - 5/16" PUMP & ABOVE
MANTOU AIR CLEANER (PLASTIC HOUSING)

3.00

4 AA 20

1ST MOUNTING
2ND MOUNTING
SUPPLIED BY ENGINE (PART NO. 94170)

4.00

4 AA 30

VIEW A

5.00

4 AA 31

6.00

4 AA 40

SEE NOTE
SEE NOTE
SEE NOTE

7.00

4 AA 50 4-SPEED

APPLY LOCTITE #2
APPLY LOCTITE #2
SEE 6441

8.00

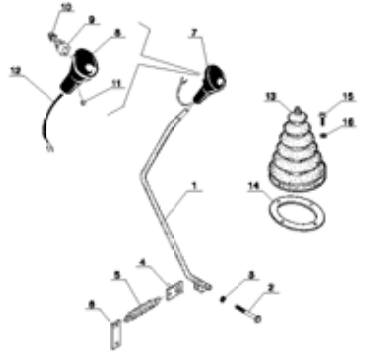
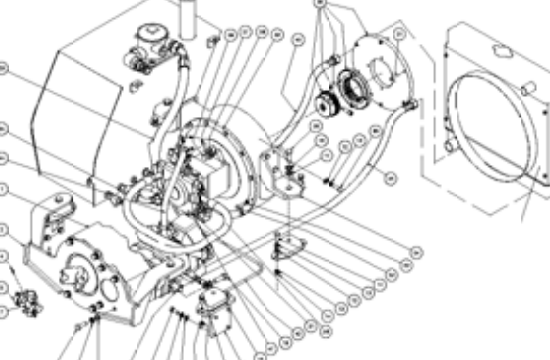
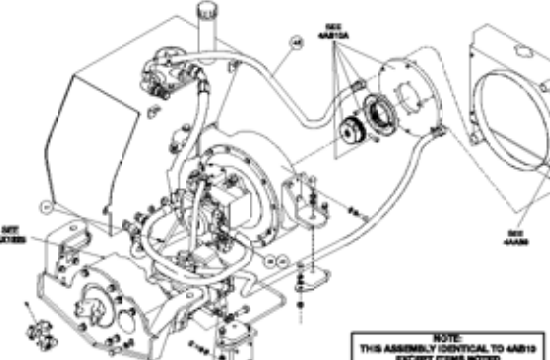
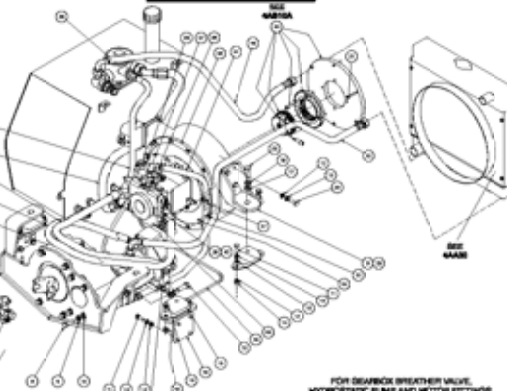
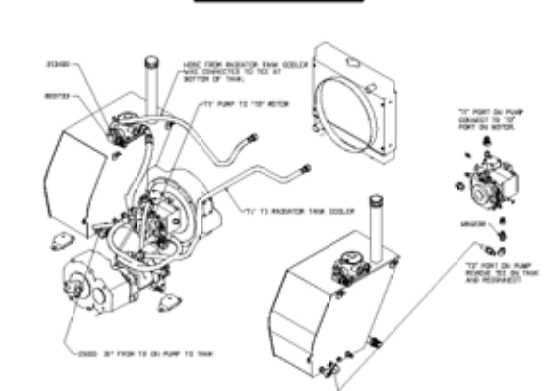
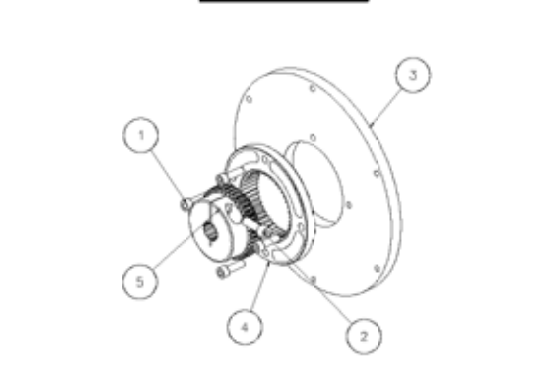
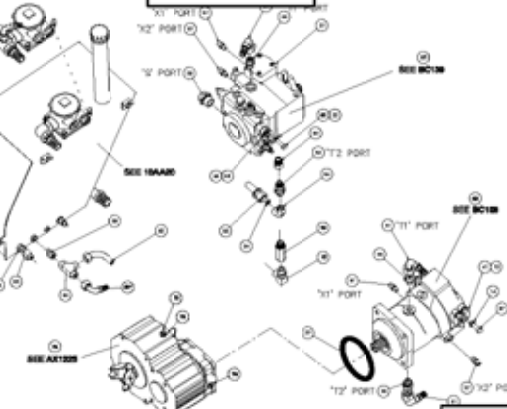
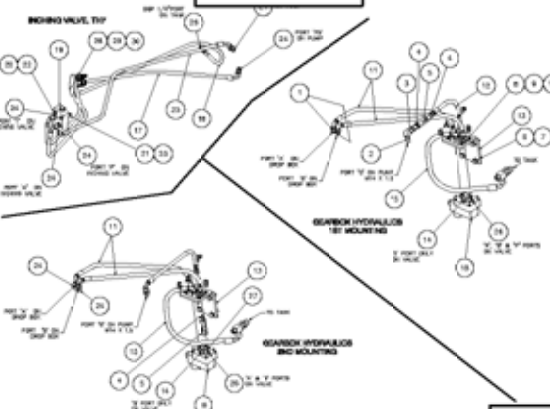
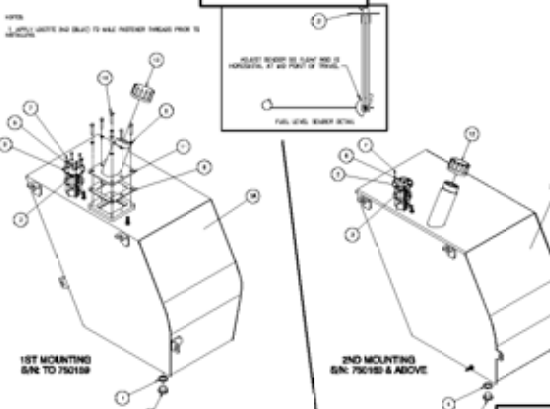
<p>4 AA 51 4-SPEED</p>  <p>9.00</p>	<p>4 AB 10 HYDROSTATIC</p>  <p>10.00</p>	<p>4 AB 10.1 HYDROSTATIC</p>  <p>NOTE: THIS ASSEMBLY IS IDENTICAL TO 4AB10 EXCEPT ITEMS NOTED</p> <p>10.10</p>
<p>4 AB 10.2</p>  <p>FOR GEARBOX BREAKER VALVE, HYDROSTATIC PUMP AND MOTOR FITTINGS, SEE 4AB11</p> <p>10.20</p>	<p>4 AB 10.5 HYDROSTATIC</p>  <p>10.50</p>	<p>4 AB 10A HYDROSTATIC</p>  <p>11.00</p>
<p>4 AB 11 HYDROSTATIC</p>  <p>12.00</p>	<p>4 AB 12</p>  <p>13.00</p>	<p>4 AC 10</p>  <p>1ST MOUNTING SIN: TO 750158</p> <p>2ND MOUNTING SIN: 750158 & ABOVE</p> <p>14.00</p>

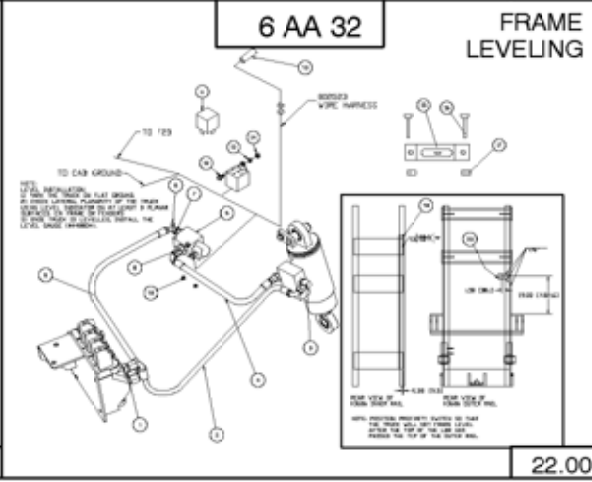
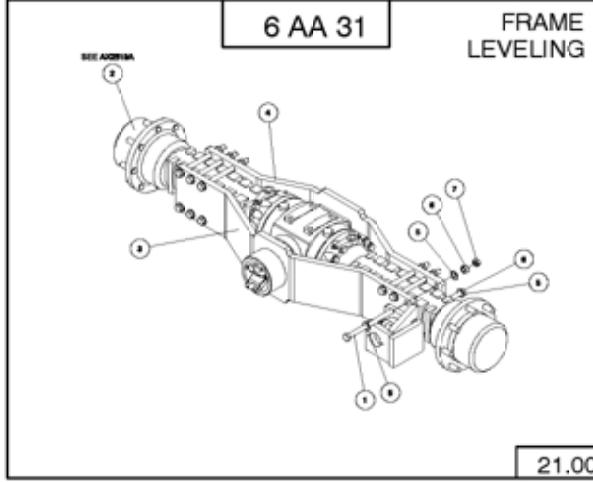
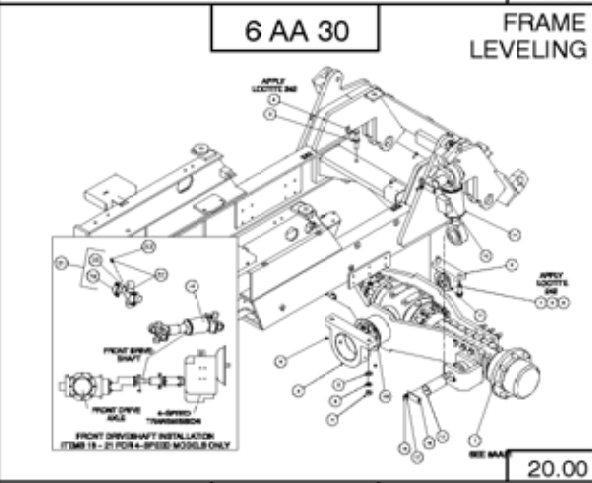
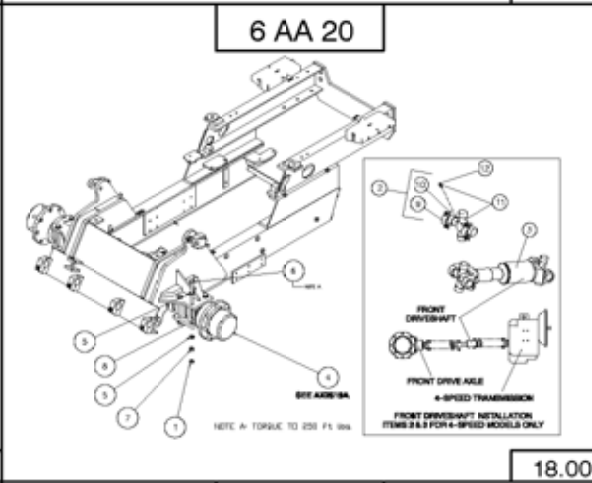
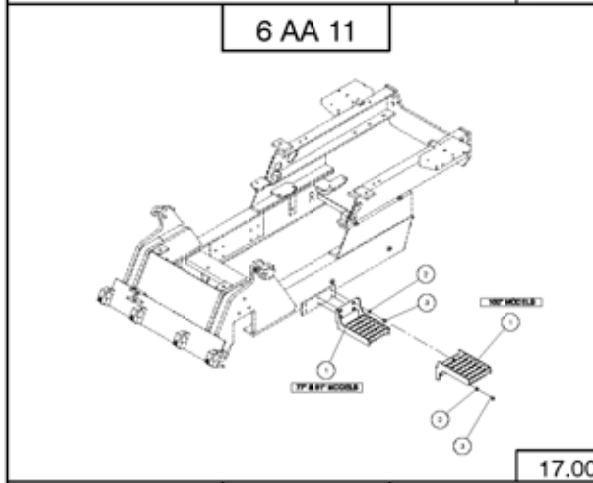
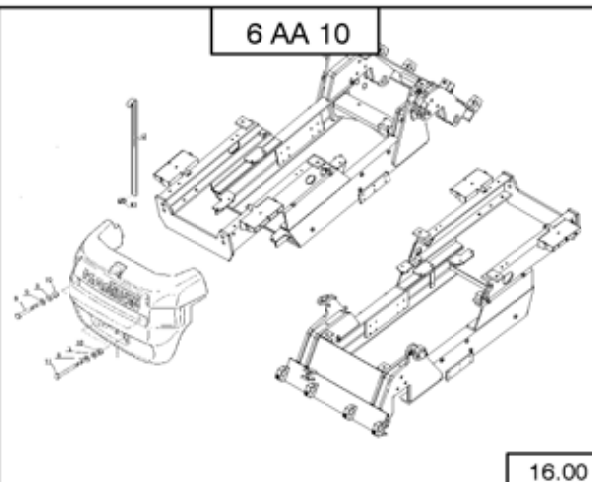
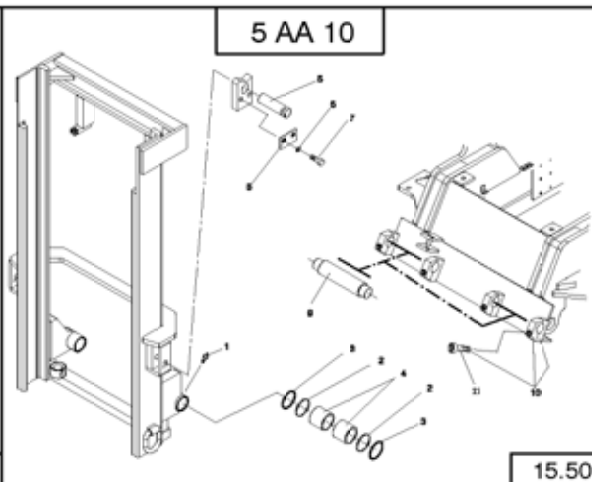
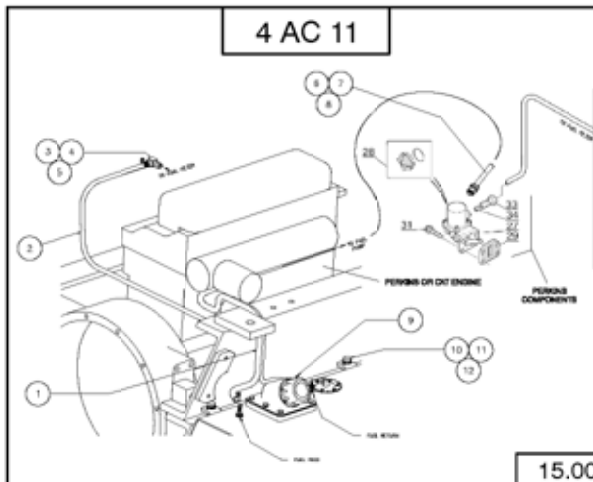

<p>6 BA 10 100 IN. CAB</p> <p>NOTE: MAINTAIN CLEARANCE BETWEEN SWITCH & FLAT WHEN HANDBRAKE ENGAGED WHEN HANDBRAKE IS NOT ENGAGED ADJUST SWITCH JUST ENOUGH TO CLOSE</p> <p style="text-align: right;">23.00</p>	<p>6 BA 20 77 & 81 IN. CAB</p> <p style="text-align: center;">VIEW A</p> <p style="text-align: right;">24.00</p>	<p>6 BA 54</p> <p style="text-align: right;">25.00</p>
<p>6 BB 10 100 IN. CAB</p> <p style="text-align: right;">26.00</p>	<p>6 BB 11 100 IN. CAB</p> <p style="text-align: right;">27.00</p>	<p>6 BB 20 77 & 81 IN. CAB</p> <p style="text-align: right;">28.00</p>
<p>6 BB 21 77 & 81 IN. CAB</p> <p>ENGINE THROTTLE NO CHANGE</p> <p>SET MOUNTING THROTTLE PEDAL SIN 75046 & BELOW</p> <p>2ND MOUNTING THROTTLE PEDAL SIN 75047 & ABOVE</p> <p style="text-align: right;">28.01</p>	<p>7 AA 10</p> <p>SEE 7AA11</p> <p>1ST MOUNTING SIN 75036 & BELOW</p> <p>2ND MOUNTING SIN 75036 & ABOVE</p> <p>NOTE: APPLY LUBRICANT TO THE SURFACE OF ALL BOLTS DURING</p> <p style="text-align: right;">29.00</p>	<p style="text-align: right;">29.00</p>

7 AA 11

1ST MOUNTING (SN 750471 & BELOW)
STEERING ASSEMBLY
80394 (DISCONTINUED)

2ND MOUNTING
(SN 750472 & ABOVE)
STEERING ASSEMBLY
80391 (REPLACES 80394)

SEE 10C816

HUB ASSEMBLY
(ITEM 12)

30.00

7 AB 10

SEE SPECIFICATIONS AND INSTRUCTIONS TO THE THREADS OF ALL BOLTS DURING INSTALLATION.

REAR DRIVE SHAFT

REAR DRIVE SHAFT INSTALLATION
(ITEMS 8 & 9 FOR HYDROSTATIC 4WD MODELS ONLY)

HYDROSTATIC DRIVE SHAFT

REAR DRIVE SHAFT

REAR DRIVE SHAFT INSTALLATION
(ITEMS 8 & 9A FOR 4-SPEED 4WD MODELS ONLY)

4-SPEED TRANSMISSION

31.00

8 AA 10 100 IN. CAB ENCLOSED

32.00

8 AA 11 100 IN. CAB ENCLOSED

33.00

8 AA 12 100 IN. CAB ENCLOSED

34.00

8 AA 13 100 IN. CAB ENCLOSED

34.01



8 AA 14 100 IN. CAB ENCLOSED

35.00

8 AA 15 100 IN. CAB ENCLOSED

36.00

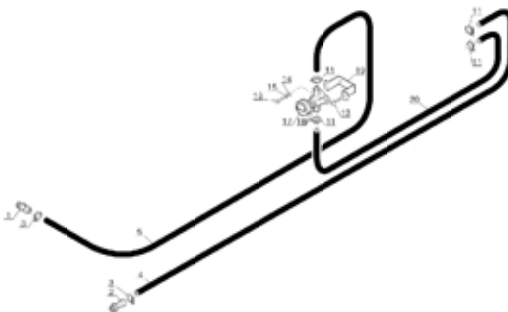
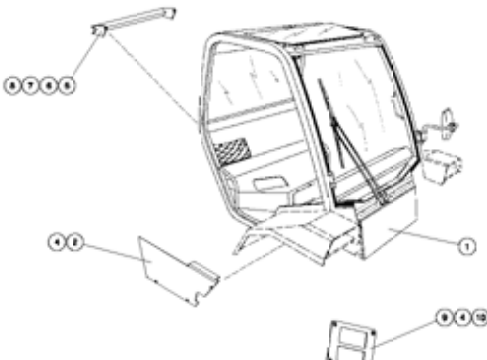
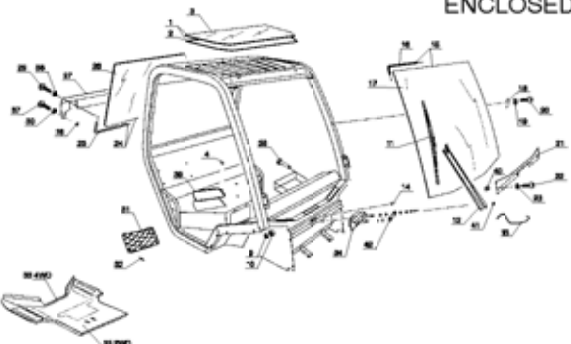
INDEX

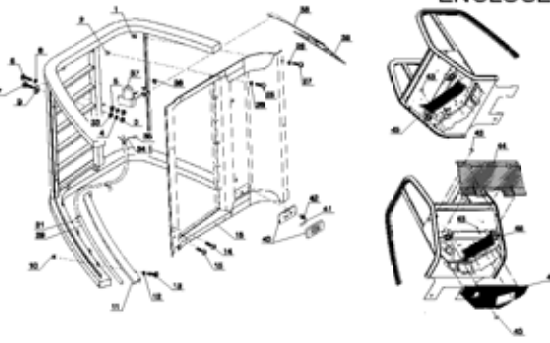
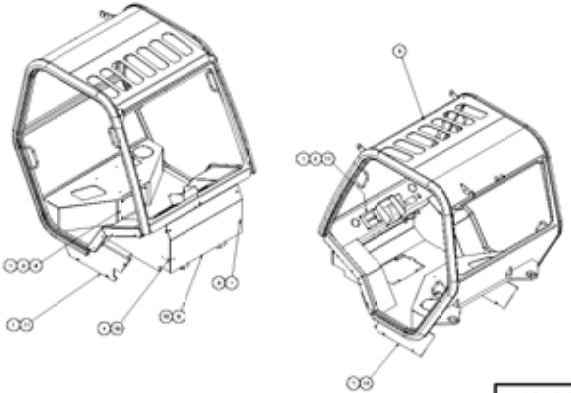
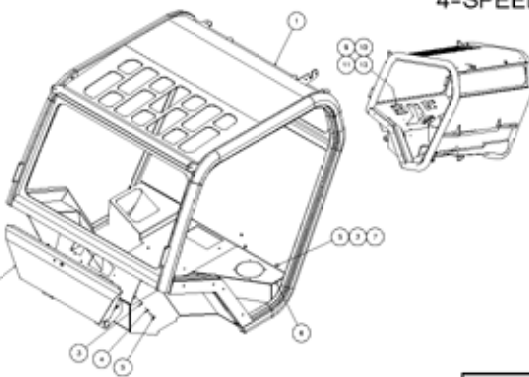
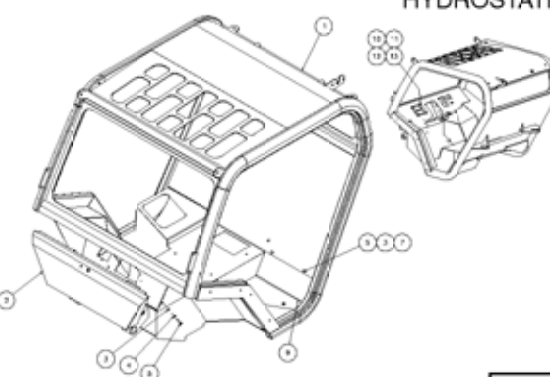
<p>8 AA 16 100 IN. CAB ENCLOSED</p>  <p style="text-align: right;">37.00</p>	<p>8 AA 20 100 IN. CAB SEMI-ENCLOSED</p>  <p style="text-align: right;">38.00</p>	<p>8 AA 21 100 IN. CAB SEMI-ENCLOSED</p>  <p style="text-align: right;">39.00</p>
<p>8 AA 22 100 IN. CAB SEMI-ENCLOSED</p>  <p style="text-align: right;">40.00</p>	<p>8 AA 23 100 IN. CAB SEMI-ENCLOSED</p>  <p style="text-align: right;">41.00</p>	<p>8 AA 30 100 IN. CAB OPEN</p>  <p style="text-align: right;">42.00</p>
<p>8 AA 40 77 & 81 IN. CAB OPEN 4-SPEED</p>  <p style="text-align: right;">43.00</p>	<p>8 AA 50 77 & 81 IN. CAB OPEN HYDROSTATIC</p>  <p style="text-align: right;">44.00</p>	<p style="text-align: right;">44.00</p>

<p>8 AA 100</p> <p>45.00</p>	<p>8 AA 101 100 IN. CAB ENCLOSED SEMI-ENCLOSED</p> <p>46.00</p>	<p>8 AA 102 100 IN. CAB OPEN</p> <p>47.00</p>
<p>8 AA 103 77 & 81 IN. CAB</p> <p>48.00</p>	<p>8 AA 104 100 IN. CAB ENCLOSED SEMI-ENCLOSED</p> <p>48.01</p>	<p>8 AA 105 100 IN. CAB OPEN</p> <p>49.00</p>
<p>8 AA 106 77 & 81 IN. CAB</p> <p>50.00</p>	<p>8 AA 110 100 IN. CAB</p> <p>51.00</p>	<p></p>

INDEX

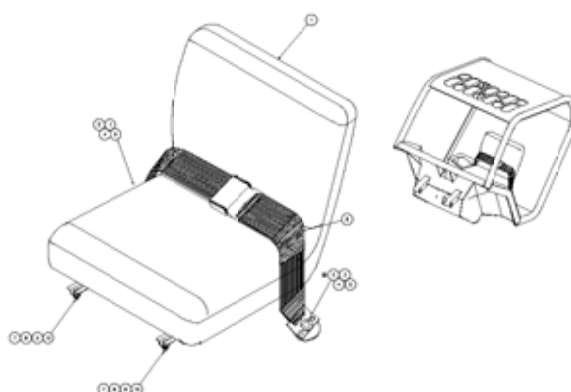
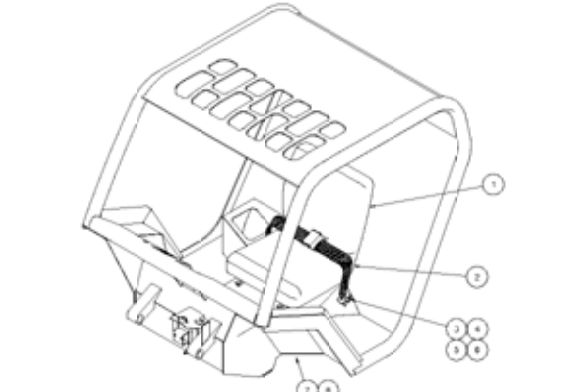
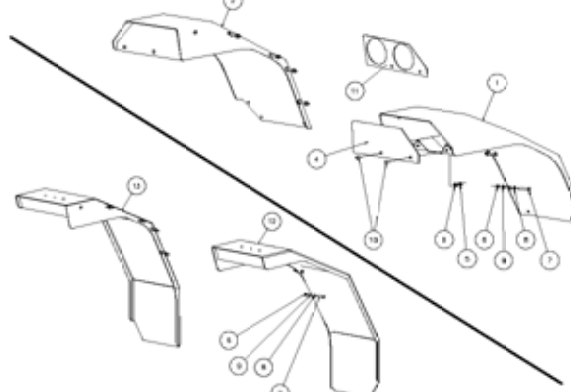
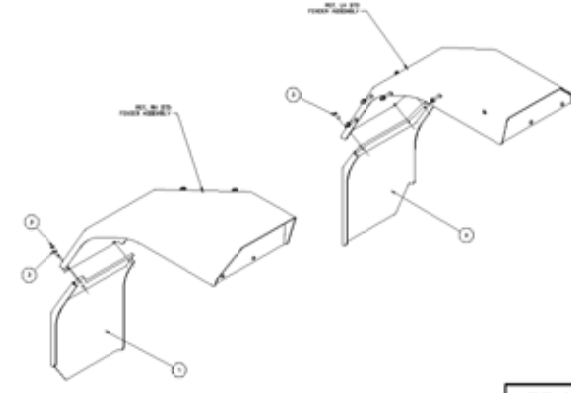
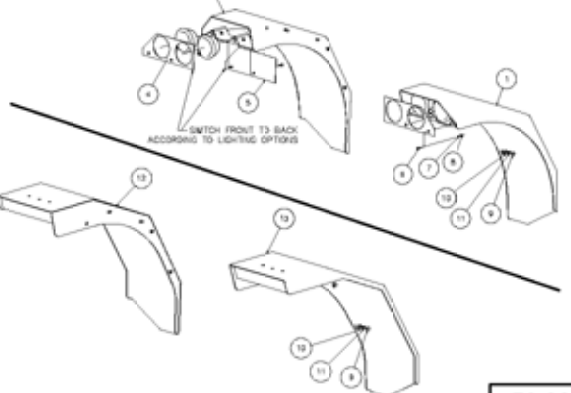
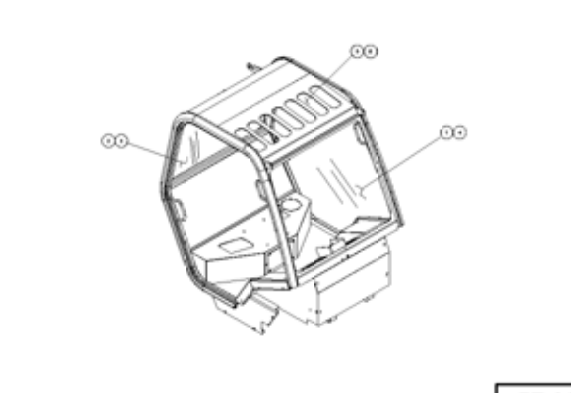
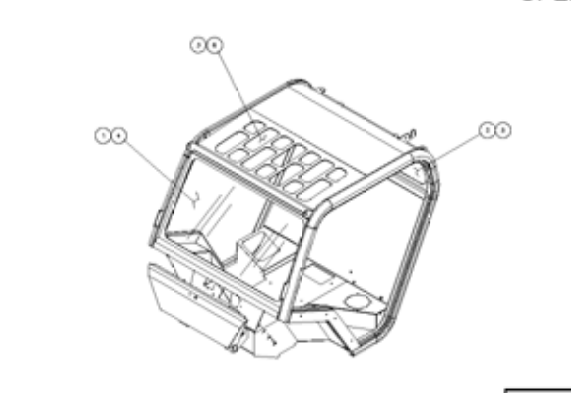
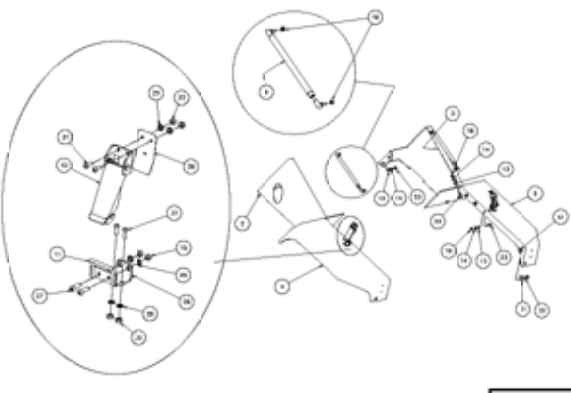
<p>8 AA 111 77 & 81 IN. CAB</p>  <p style="text-align: right;">52.00</p>	<p>8 AA 112 77 & 81 IN. CAB</p>  <p style="text-align: right;">53.00</p>	<p>8 AA 120 100 IN. CAB</p>  <p style="text-align: right;">54.00</p>
<p>8 AA 121 100 IN. CAB</p>  <p style="text-align: right;">55.00</p>	<p>8 AA 122 77 & 81 IN. CAB</p>  <p style="text-align: right;">56.00</p>	<p>8 AA 123 100 IN. CAB OPEN</p>  <p style="text-align: right;">57.00</p>
<p>8 AA 124 77 & 81 IN. CAB OPEN</p>  <p style="text-align: right;">58.00</p>	<p>9 AA 10</p>  <p style="text-align: right;">59.00</p>	<p style="text-align: right;">59.00</p>

<p style="text-align: center;">9 AA 11</p> <p style="text-align: right;">60.00</p>	<p style="text-align: center;">10 AA 10 4-SPEED</p> <p style="text-align: right;">61.00</p>	<p style="text-align: center;">10 AA 20 HYDROSTATIC</p> <p style="text-align: right;">62.00</p>
<p style="text-align: center;">10 AA 30</p> <p style="text-align: right;">62.01</p>	<p style="text-align: center;">10 AA 40</p> <p style="text-align: right;">62.02</p>	<p style="text-align: center;">10 AE 10</p> <p style="text-align: right;">63.00</p>
<p style="text-align: center;">10 AE 11</p> <p style="text-align: right;">63.01</p>	<p style="text-align: center;">10 AF 10</p> <p style="text-align: right;">64.00</p>	<p style="text-align: center;"> </p> <p style="text-align: right;"> </p>

<p>10 BA 10</p> <p>65.00</p>	<p>10 CE 15</p> <p>65.01</p>	<p>10 DA 88</p> <p>66.00</p>
<p>11 AA 10 4-SPEED</p> <p>67.00</p>	<p>11 AA 11 4-SPEED</p> <p>67.01</p>	<p>11 AA 20 HYDROSTATIC</p> <p>68.00</p>
<p>11 AA 21 HYDROSTATIC</p> <p>68.01</p>	<p>11 AB 10</p> <p>68.50</p>	<p></p>

11 BA 10

69.00

11 BA 20 ROAD LIGHTS

Wiring diagram for road lights including a '1ST MOUNTING HEADLIGHTS' section and a '2ND MOUNTING HEADLIGHTS' section. Includes a 'WIRING DIAGRAM' table and a 'COVER SHOWN FROM BACK' view.

70.00

11 BA 30 POULTRY LIGHTS

71.00

11 BA 40

72.00

11 CC 09

72.01

11 CC 10

73.00

11 CC 11 100 IN. CAB (802656) OPEN

74.00

11 CC 12 77 & 81 IN. CAB OPEN

75.00

11 CC 13

TACHOMETER
ACCESSORY PLUG CAB (EXISTING)
ALTERNATOR

76.00

11 CC 14

1ST MOUNTING
2ND MOUNTING
TACHOMETER
WIRING
MOUNTING

77.00

11 CD 10

BATTERY 12V
STARTER
FUSE POSTION 23
REPLACE ORIGINAL GREEN WIRE
REPLACE ORIGINAL PURPLE WIRE
REPLACE ORIGINAL RED WIRE
REPLACE ORIGINAL BLACK WIRE
REPLACE ORIGINAL 1/4 INCH WIRE
REPLACE ORIGINAL 3/16 INCH WIRE
REPLACE ORIGINAL 1/8 INCH WIRE
REPLACE ORIGINAL 1/4 INCH WIRE
REPLACE ORIGINAL 3/16 INCH WIRE
REPLACE ORIGINAL 1/8 INCH WIRE

1ST MOUNTING
2ND MOUNTING
3RD MOUNTING

78.00

11 CD 20

BATTERY 12V
STARTER
FUSE POSTION 23
REPLACE ORIGINAL GREEN WIRE
REPLACE ORIGINAL PURPLE WIRE
REPLACE ORIGINAL RED WIRE
REPLACE ORIGINAL BLACK WIRE
REPLACE ORIGINAL 1/4 INCH WIRE
REPLACE ORIGINAL 3/16 INCH WIRE
REPLACE ORIGINAL 1/8 INCH WIRE

1ST MOUNTING
2ND MOUNTING
3RD MOUNTING

79.00

11 CD 30

1ST MOUNTING
TACHOMETER
WIRING
MOUNTING

79.50

11 CD 31

2ND MOUNTING
TACHOMETER
WIRING
MOUNTING

79.51

11 CD 58

1ST MOUNTING
TACHOMETER
WIRING
MOUNTING

80.00

12 AA 10 DECALS

1
2
3
4
5
6
7
8
9
10

81.00

12 AA 11 DECALS

1
2
3
4
5
6
7
8
9
10

81.00

<p style="text-align: center;">AP 2054 PERKINS</p> <p style="text-align: right;">82.00</p>	<p style="text-align: center;">AP 1430 PERKINS</p> <p style="text-align: right;">83.00</p>	<p style="text-align: center;">AP 1432 PERKINS</p> <p style="text-align: right;">84.00</p>
<p style="text-align: center;">AP 1434 PERKINS</p> <p style="text-align: right;">85.00</p>	<p style="text-align: center;">AP 1435 PERKINS</p> <p style="text-align: right;">86.00</p>	<p style="text-align: center;">AP 1436 PERKINS</p> <p style="text-align: right;">87.00</p>
<p style="text-align: center;">AP 1437 PERKINS</p> <p style="text-align: right;">88.00</p>	<p style="text-align: center;">TIER 2 PERKINS CAT</p> <p style="text-align: right;">88.10</p>	<p style="text-align: center;">[Empty Box]</p>

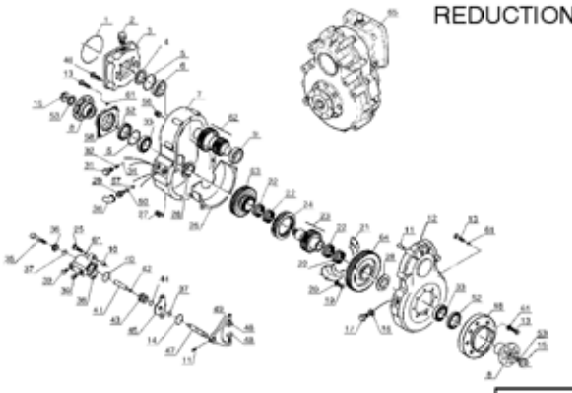
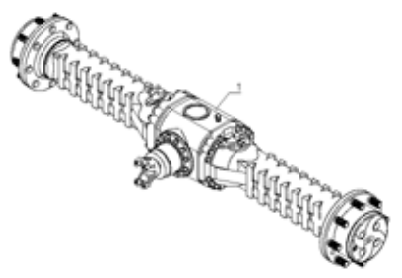
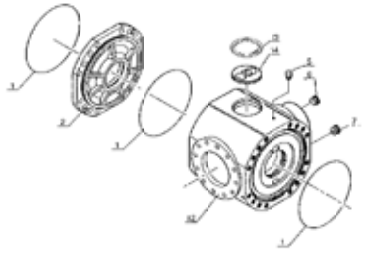
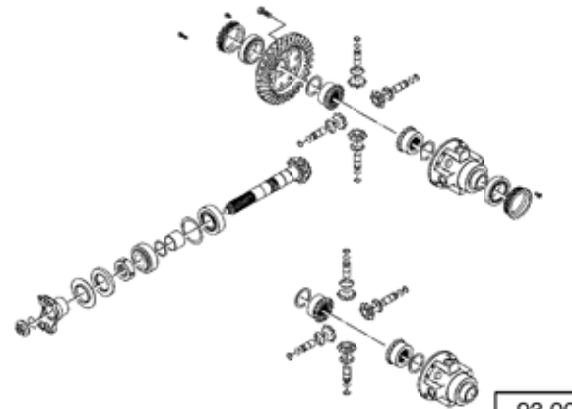
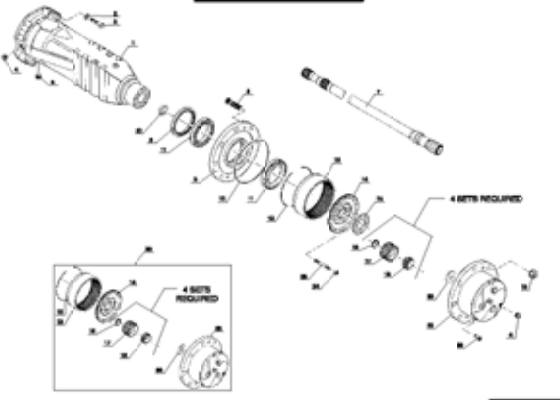
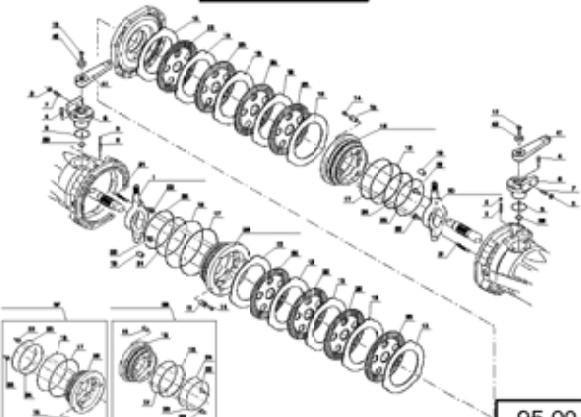
<p>AX 1225 GEARBOX, 2-SPEED REDUCTION</p>  <p style="text-align: right;">90.00</p>	<p>AX 2519A FRONT AXLE</p>  <p style="text-align: right;">91.00</p>	<p>AX 1412 FRONT AXLE</p>  <p style="text-align: right;">92.00</p>
<p>AX 1449 FRONT AXLE</p>  <p style="text-align: right;">93.00</p>	<p>AX 1450 FRONT AXLE</p>  <p style="text-align: right;">94.00</p>	<p>AX 1415 FRONT AXLE</p>  <p style="text-align: right;">95.00</p>
<p style="text-align: center;">[]</p>	<p style="text-align: center;">[]</p>	<p style="text-align: center;">[]</p>

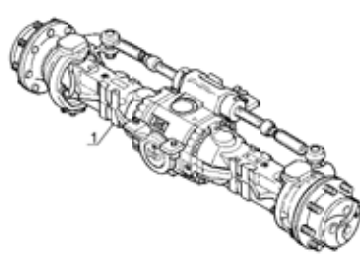
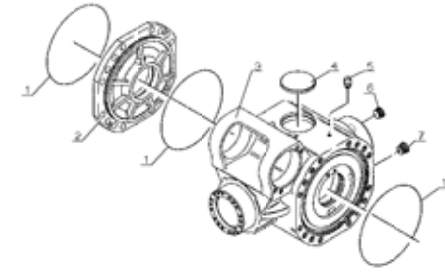
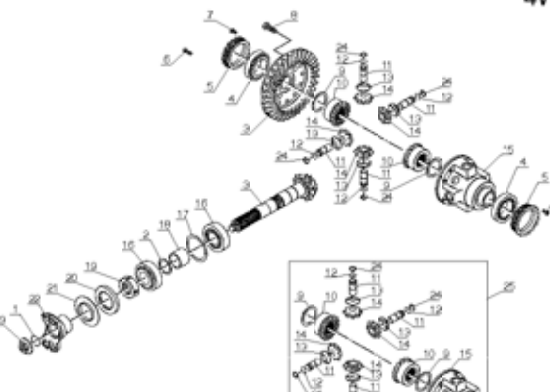
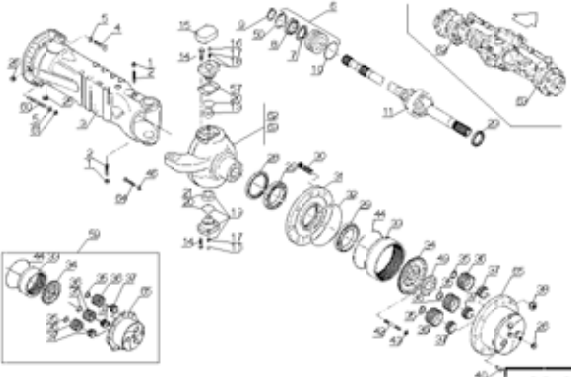
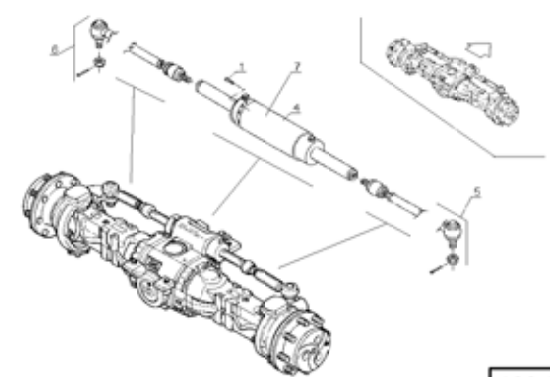
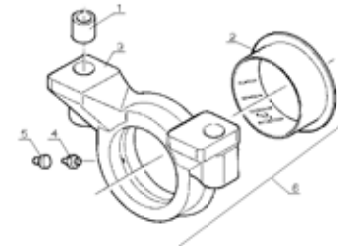
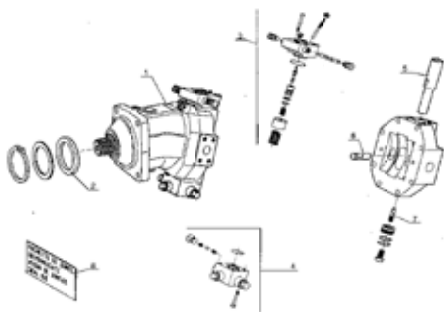
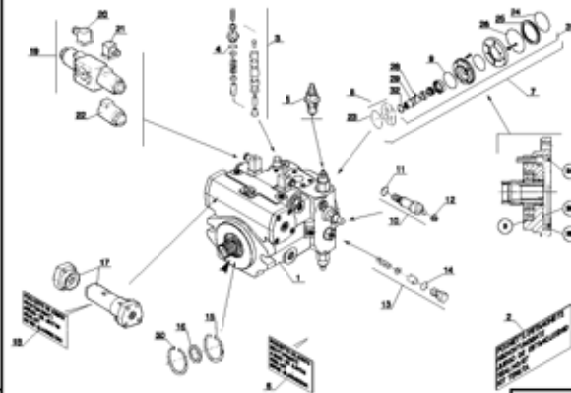
<p style="text-align: center;">AX 2520 REAR AXLE 4WD</p>  <p style="text-align: right;">96.00</p>	<p style="text-align: center;">AX 1416 REAR AXLE 4WD</p>  <p style="text-align: right;">97.00</p>	<p style="text-align: center;">AX 1417 REAR AXLE 4WD</p>  <p style="text-align: right;">98.00</p>
<p style="text-align: center;">AX 1418 REAR AXLE 4WD</p>  <p style="text-align: right;">99.00</p>	<p style="text-align: center;">AX 1419 REAR AXLE 4WD</p>  <p style="text-align: right;">100.00</p>	<p style="text-align: center;">AX 1420 REAR AXLE 4WD</p>  <p style="text-align: right;">101.00</p>
<p style="text-align: center;">BC 108</p>  <p style="text-align: right;">102.00</p>	<p style="text-align: center;">BC 139</p>  <p style="text-align: right;">103.00</p>	<p style="text-align: center;"> </p> <p style="text-align: right;"> </p>

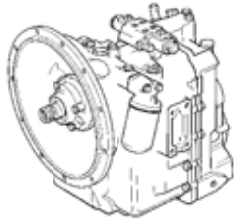
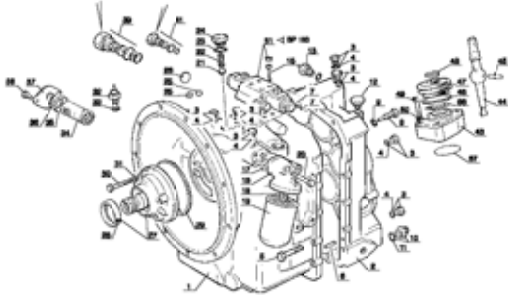
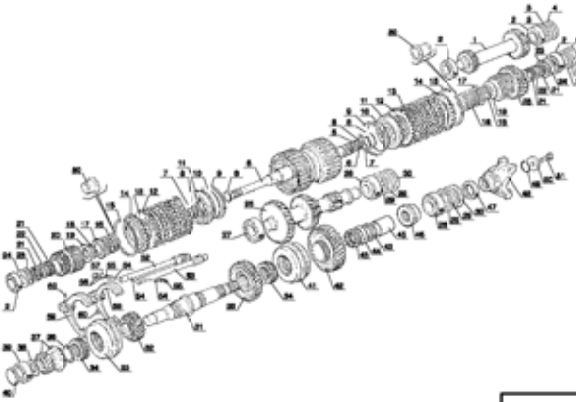
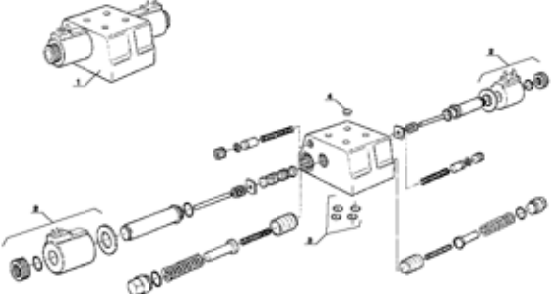
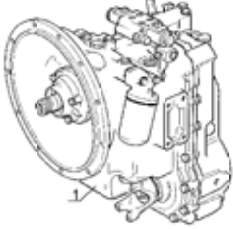
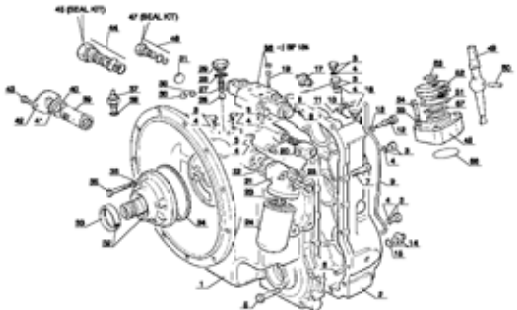
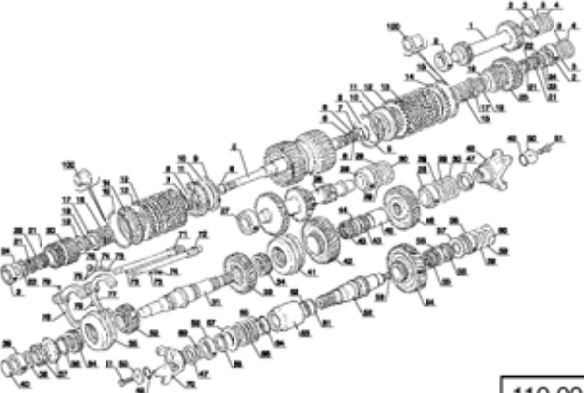
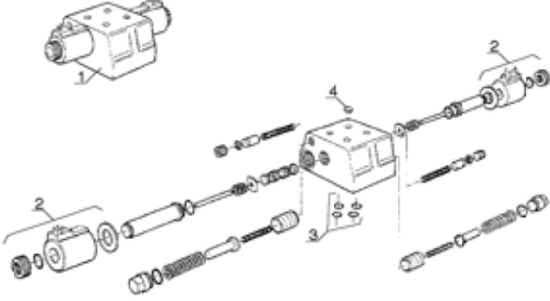
<p style="text-align: center;">BP 177 4-SPEED, 2WD</p>  <p style="text-align: right;">104.00</p>	<p style="text-align: center;">BP 178 4-SPEED, 2WD</p>  <p style="text-align: right;">105.00</p>	<p style="text-align: center;">BP 179 4-SPEED, 2WD</p>  <p style="text-align: right;">106.00</p>
<p style="text-align: center;">BP 180 4-SPEED, 2WD</p>  <p style="text-align: right;">107.00</p>	<p style="text-align: center;">BP 181 4-SPEED, 4WD</p>  <p style="text-align: right;">108.00</p>	<p style="text-align: center;">BP 182 4-SPEED, 4WD</p>  <p style="text-align: right;">109.00</p>
<p style="text-align: center;">BP 183 4-SPEED, 4WD</p>  <p style="text-align: right;">110.00</p>	<p style="text-align: center;">BP 184 4-SPEED, 4WD</p>  <p style="text-align: right;">111.00</p>	<p style="text-align: center;">[Empty Box]</p> <p style="text-align: right;">[Empty Box]</p>

2 AA 79A

FILTERS AND BELTS

M30-2	M30-4	M30-2 H	M30-4 H
M40-2	M40-4	M40-2 H	M40-4 H
M50-2	M50-4	M50-2 H	M50-4 H
M60-2	M60-4	M60-2 H	M60-4 H
M30-2 L	M30-4 L	M30-2 H L	M30-4 H L
M40-2 L	M40-4 L	M40-2 H L	M40-4 H L
M50-2 L	M50-4 L	M50-2 H L	M50-4 H L
M60-2 L	M60-4 L	M60-2 H L	M60-4 H L

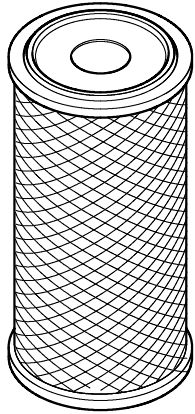

Air filter cartridge
563416 MANITOU
803655 NELSON

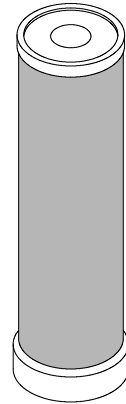

Safety air filter cartridge
563415 MANITOU
803654 NELSON

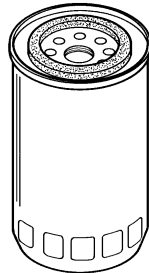

133755
 Engine oil filter
 Cat or Perkins

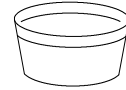

128592
 Perkins fuel filter bowl,
 glass w/o hardware



494171*
 Cat Engine fuel filter
 (Quick-fit, no glass bowl)
421206*
 Perkins Engine fuel filter
 (requires glass bowl, not included)

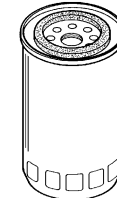

561749
 Transmission oil filter
 (4-speed transmission)

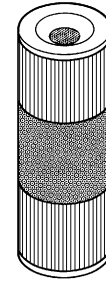

221174 (4-speed)
 Hydraulic return oil filter
602096 (Hydrostatic)
 Hydraulic return oil filter

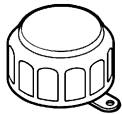

425501
 Filter cap for
 hydraulic oil tank

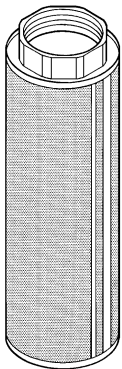

424764
 Suction strainer
 (inside hydraulic oil tank)

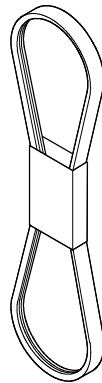

474948
 Fan belt, alternator
 S/N: 750284 &
 BELOW

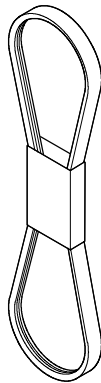

496816
 Fan belt, alternator
 S/N: 750285 &
 ABOVE

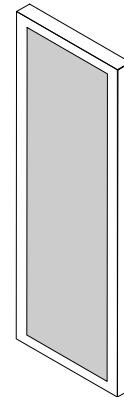

562185
 Cab vent filter
 (100 in. enclosed cab)

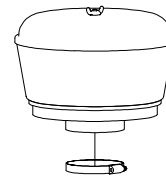

803071
 Air Intake Pre-filter
B2236-15 clamp

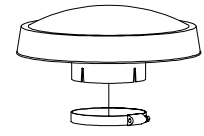

508565
 Rain Cap Pre-filter
 & clamp
470680 clamp



160946
 Turbo II Engine
 pre-filter & clamp

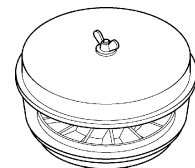

224713
 Cyclonic Engine
 pre-filter & clamp

* The fuel filters are not interchangeable.

3 AA 10

TIRES AND WHEELS, FRONT

M30-2	M30-4	M30-2 H	M30-4 H
M40-2	M40-4	M40-2 H	M40-4 H
M50-2	M50-4	M50-2 H	M50-4 H
M60-2	M60-4	M60-2 H	M60-4 H
M30-2 L	M30-4 L	M30-2 H L	M30-4 H L
M40-2 L	M40-4 L	M40-2 H L	M40-4 H L
M50-2 L	M50-4 L	M50-2 H L	M50-4 H L
M60-2 L	M60-4 L	M60-2 H L	M60-4 H L

TITAN TREAD 802988 (STD WHEEL)
TITAN TREAD 804133 (NARROW WHEEL)

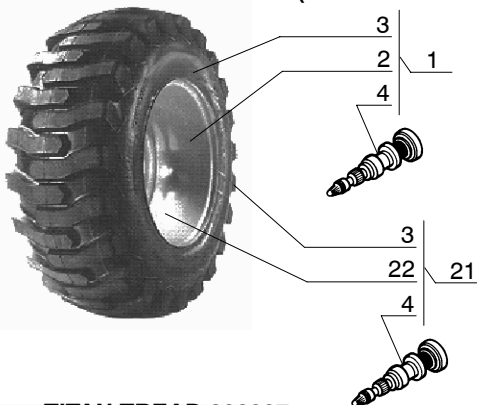

TITAN TREAD 802997

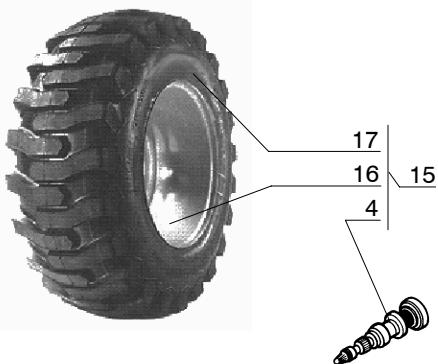

TITAN TREAD 803000

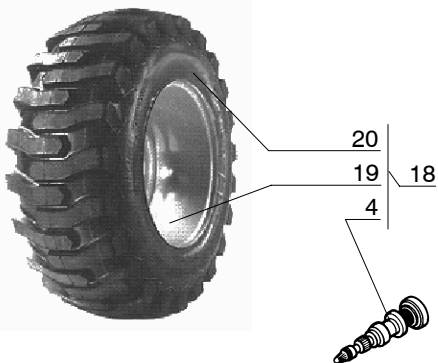

GOOD YEAR TREAD 803006

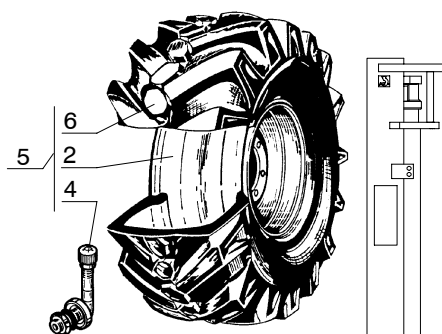

OTR TREAD 802673

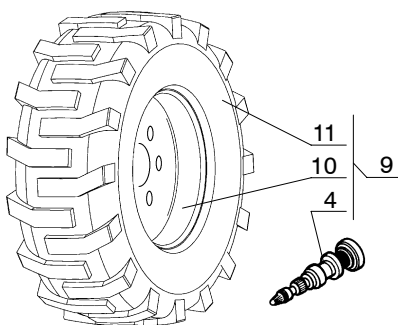

MICHELIN TREAD 803010

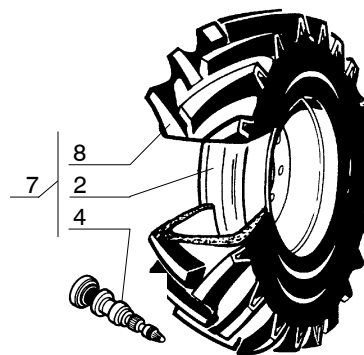

MICHELIN TREAD 802895

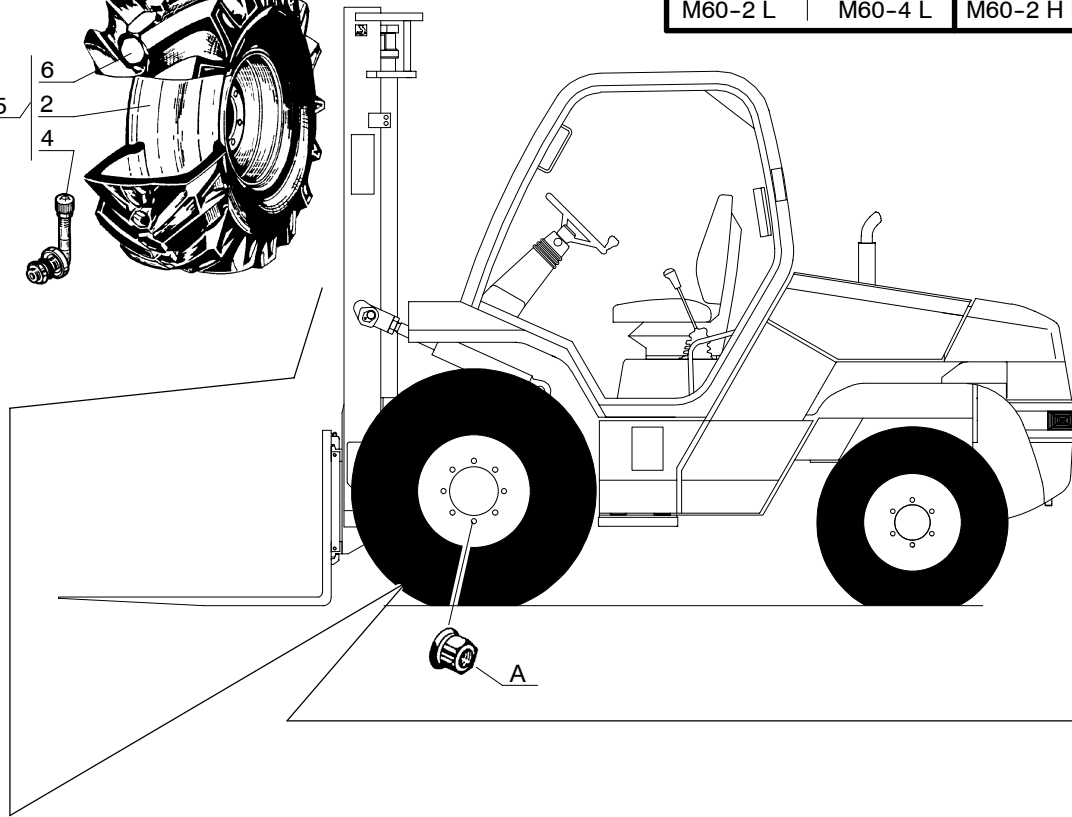
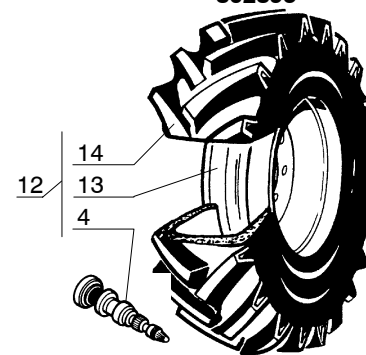

1	TIRES AND WHEELS, FRONT													3 AA 10					
	ITEM	PART NO.	DESCRIPTION	M30-4	M40-4	M50-4	M60-4	M30-4 H	M40-4 H	M50-4 H	M60-4 H	M30-4 L	M40-4 L	M50-4 L	M60-4 L	M30-4 H L	M40-4 H L	M50-4 H L	M60-4 H L
A	109480	Nut, drive wheel	A/R	A/R	A/R	A/R	A/R	A/R	A/R	A/R	A/R	A/R	A/R	A/R	A/R	A/R	A/R	A/R	A/R
1	802988R	Front wheel assembly, RH (100 & 81 in. cabs, 6K) Titan 17.5x24 R-4	1				1					1				1			
1	802988L	Front wheel assembly, LH (100 & 81 in. cabs, 6K) Titan 17.5x24 R-4	1				1					1				1			
2	802989	Front wheel (100 & 81 in. cabs, 6K)	A/R				A/R					A/R				A/R			
3	802127	Front tire, Titan 17.5x24 R-4 (100 & 81 in. cabs, 6K)	A/R				A/R					A/R				A/R			
4	802118	Tire valve, front	A/R	A/R	A/R	A/R	A/R	A/R	A/R	A/R	A/R	A/R	A/R	A/R	A/R	A/R	A/R	A/R	A/R
5	803006R	Front wheel assembly, RH (100 & 81 in. cabs, 6K) Good Year 16.9x24 R-4	1				1					1				1			
5	803006L	Front wheel assembly, LH (100 & 81 in. cabs, 6K) Good Year 16.9x24 R-4	1				1					1				1			
6	803007	Front tire, Good Year 16.9x24 R-4 (100 & 81 in. cabs, 6K)	A/R				A/R					A/R				A/R			
7	803010R	Front wheel assembly, RH (100 & 81 in. cabs, 6K) Michelin 17.5x24 XM27	1				1					1				1			
7	803010L	Front wheel assembly, LH (100 & 81 in. cabs, 6K) Michelin 17.5x24 XM27	1				1					1				1			
8	803011	Front tire, Michelin 17.5x24 XM27 (100 & 81 in. cabs, 6K)	A/R				A/R					A/R				A/R			
9	802673R	Front wheel assembly, RH (77 in. cab, 6K) OTR 15x19.5	1				1					1				1			
9	802673L	Front wheel assembly, LH (77 in. cab, 6K) OTR 15x19.5	1				1					1				1			

2	TIRES AND WHEELS, FRONT		QUANTITY / MODEL												3 AA 10			
			M30-4	M40-4	M50-4	M60-4	M30-4 H	M40-4 H	M50-4 H	M60-4 H	M30-4 L	M40-4 L	M50-4 L	M60-4 L	M30-4 H L	M40-4 H L	M50-4 H L	M60-4 H L
ITEM	PART NO.	DESCRIPTION	M30-2	M40-2	M50-2	M60-2	M30-2 H	M40-2 H	M50-2 H	M60-2 H	M30-2 L	M40-2 L	M50-2 L	M60-2 L	M30-2 H L	M40-2 H L	M50-2 H L	M60-2 H L
10	802113	Front wheel (77 in. cab, 6K)	A/R				A/R				A/R				A/R			
11	802126	Front tire, OTR 15x19.5 (77 in. cab, 6K)	A/R				A/R				A/R				A/R			
12	802895R	Front wheel assembly, RH (77 in. cab, 6K) Michelin 375/75R20 XM27	1				1				1				1			
12	802895L	Front wheel assembly, LH (77 in. cab, 6K) Michelin 375/75R20 XM27	1				1				1				1			
13	802896	Front wheel (77 in. cab, 6K)	A/R				A/R				A/R				A/R			
14	802964	Front tire, Michelin 375/75R20 XM27 (77 in. cab, 6K)	A/R				A/R				A/R				A/R			
15	802997R	Front wheel assembly, RH (100 & 81 in. cabs, 8K & 10K) Titan 15.5x25 L-2		1	1			1	1			1	1			1	1	
15	802997L	Front wheel assembly, LH (100 & 81 in. cabs, 8K & 10K) Titan 15.5x25 L-2		1	1			1	1			1	1			1	1	
16	802998	Front wheel (100 & 81 in. cabs, 8K & 10K)		A/R	A/R			A/R	A/R			A/R	A/R			A/R	A/R	
17	802128	Front tire, Titan 15.5x25 L-2 (100 & 81 in. cabs, 8K & 10K)		A/R	A/R			A/R	A/R			A/R	A/R			A/R	A/R	
18	803000R	Front wheel assembly, RH (100 & 81 in. cabs, 12K) Titan 17.5x25 L-2				1				1				1				1
18	803000L	Front wheel assembly, LH (100 & 81 in. cabs, 12K) Titan 17.5x25 L-2				1				1				1				1
19	803001	Front wheel (100 & 81 in. cabs, 12K)				A/R				A/R				A/R				A/R
20	802660	Front tire, Titan 17.5x25 L-2 (100 & 81 in. cabs, 12K)				A/R				A/R				A/R				A/R
21	804133R	Front wheel assembly, RH (100 & 81 in. cabs, 6K) Titan 17.5x24 R-4	1				1				1				1			
21	804133L	Front wheel assembly, LH (100 & 81 in. cabs, 6K) Titan 17.5x24 R-4	1				1				1				1			
22	804131	Front wheel (100 & 81 in. cabs, 6K)	A/R				A/R				A/R				A/R			

3 AA 20

TIRES AND WHEELS, REAR

M30-2	M30-4	M30-2 H	M30-4 H
M40-2	M40-4	M40-2 H	M40-4 H
M50-2	M50-4	M50-2 H	M50-4 H
M60-2	M60-4	M60-2 H	M60-4 H
M30-2 L	M30-4 L	M30-2 H L	M30-4 H L
M40-2 L	M40-4 L	M40-2 H L	M40-4 H L
M50-2 L	M50-4 L	M50-2 H L	M50-4 H L
M60-2 L	M60-4 L	M60-2 H L	M60-4 H L

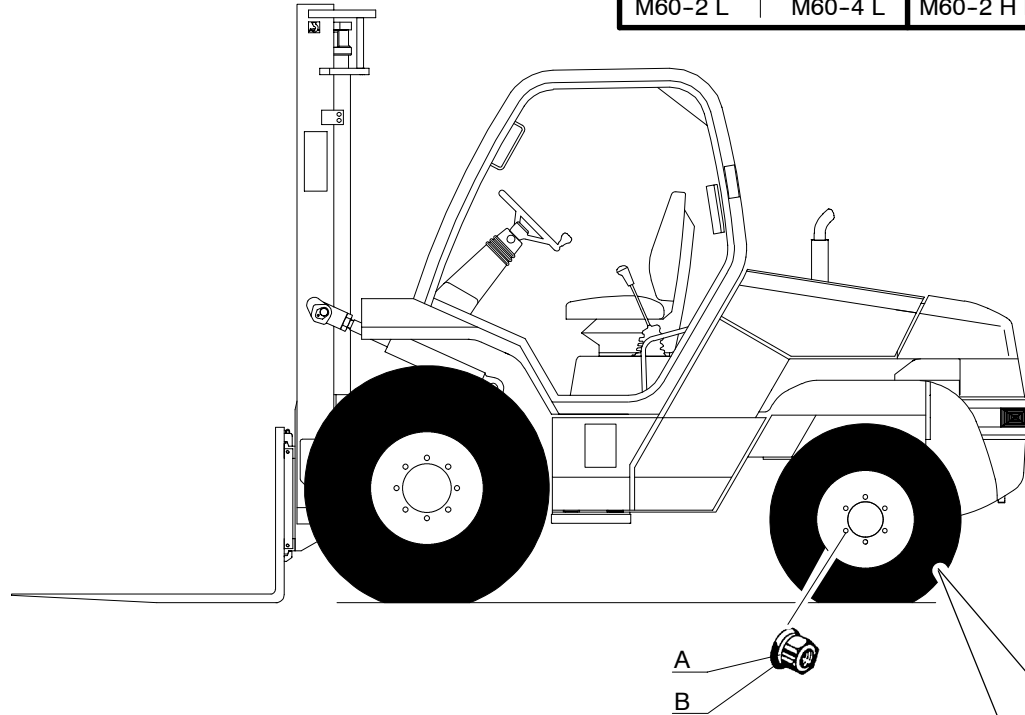

OTR TREAD 802991 (2WD)

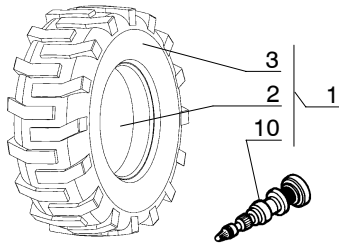

OTR TREAD 802674 (2WD)

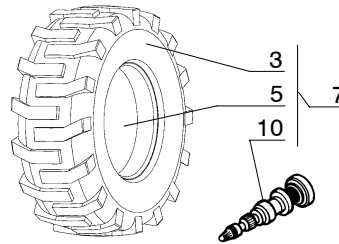

OTR TREAD 802994 (4WD)

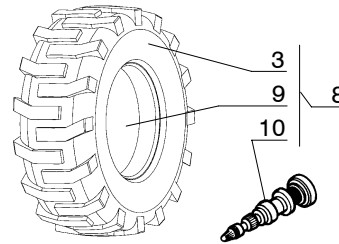

MICHELIN TREAD 803003 (2WD)

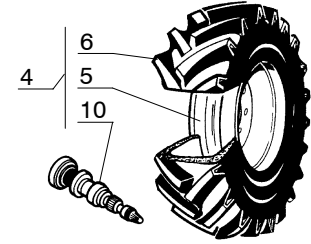

1	TIRES AND WHEELS, REAR												3 AA 20						
	ITEM	PART NO.	DESCRIPTION	M30-2	M40-2	M50-2	M60-2	M30-2 H	M40-2 H	M50-2 H	M60-2 H	M30-2 L	M40-2 L	M50-2 L	M60-2 L	M30-2 HL	M40-2 HL	M50-2 HL	M60-2 HL
A	421116	Nut, rear steer wheel (2WD ONLY)	A/R	A/R	A/R	A/R	A/R	A/R	A/R	A/R	A/R	A/R	A/R	A/R	A/R	A/R	A/R	A/R	A/R
B	475260	Nut, rear steer wheel (4WD ONLY)	A/R	A/R	A/R	A/R	A/R	A/R	A/R	A/R	A/R	A/R	A/R	A/R	A/R	A/R	A/R	A/R	A/R
1	802991R	Rear wheel assembly, RH (100 & 81 in. cabs, 6K - 12K) OTR 12x16.5	1	1	1	1	1	1	1	1	1	1	1	1	1	1	1	1	1
1	802991L	Rear wheel assembly, LH (100 & 81 in. cabs, 6K - 12K) OTR 12x16.5	1	1	1	1	1	1	1	1	1	1	1	1	1	1	1	1	1
2	802992	Rear wheel (100 & 81 in. cabs, 6K - 12K)	A/R	A/R	A/R	A/R	A/R	A/R	A/R	A/R	A/R	A/R	A/R	A/R	A/R	A/R	A/R	A/R	A/R
3	802661	Rear tire, OTR 12x16.5 (100 & 81 in. cabs, 6K - 12K)1	A/R	A/R	A/R	A/R	A/R	A/R	A/R	A/R	A/R	A/R	A/R	A/R	A/R	A/R	A/R	A/R	A/R
4	803003R	Rear wheel assembly, RH (100, 81 & 77 in. cabs, 6K) Michelin 12x16.5 XZSL	1				1				1				1				
4	803003L	Rear wheel assembly, LH (100, 81 & 77 in. cabs, 6K) Michelin 12x16.5 XZSL	1				1				1				1				
5	802114	Rear wheel (100, 81 & 77 in. cabs, 6K)	A/R	A/R	A/R	A/R	A/R	A/R	A/R	A/R	A/R	A/R	A/R	A/R	A/R	A/R	A/R	A/R	A/R
6	803004	Rear tire, Michelin 12x16.5 XZSL (100, 81 & 77 in. cabs, 6K)	A/R	A/R	A/R	A/R	A/R	A/R	A/R	A/R	A/R	A/R	A/R	A/R	A/R	A/R	A/R	A/R	A/R
7	802674R	Rear wheel assembly, RH (77 in. cab, 6K) OTR 12x16.6	1				1				1				1				
7	802674L	Rear wheel assembly, LH (77 in. cab, 6K) OTR 12x16.6	1				1				1				1				

4 AA 10

AIR INTAKE SYSTEM, INSTALLATION

M30-2	M30-4	M30-2 H	M30-4 H
M40-2	M40-4	M40-2 H	M40-4 H
M50-2	M50-4	M50-2 H	M50-4 H
M60-2	M60-4	M60-2 H	M60-4 H
M30-2 L	M30-4 L	M30-2 H L	M30-4 H L
M40-2 L	M40-4 L	M40-2 H L	M40-4 H L
M50-2 L	M50-4 L	M50-2 H L	M50-4 H L
M60-2 L	M60-4 L	M60-2 H L	M60-4 H L

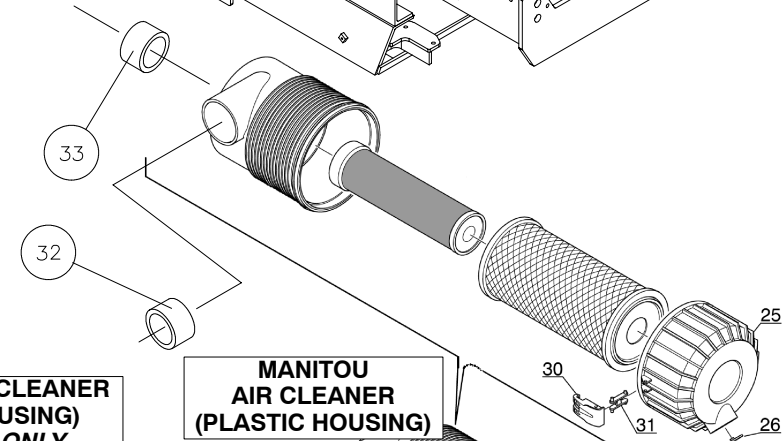
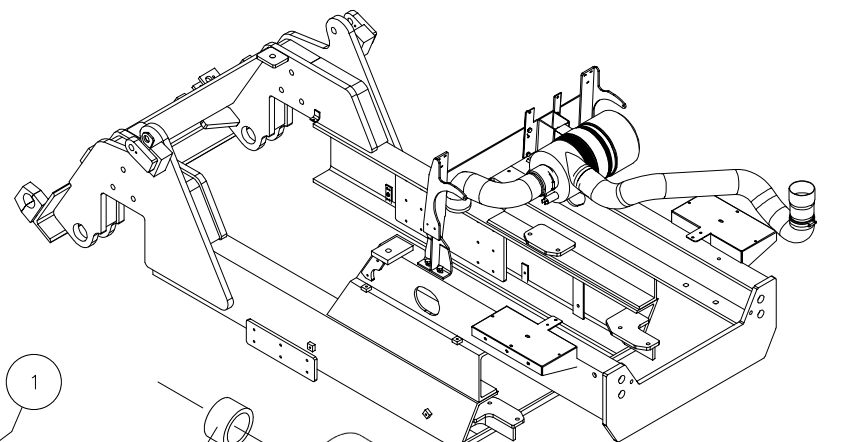
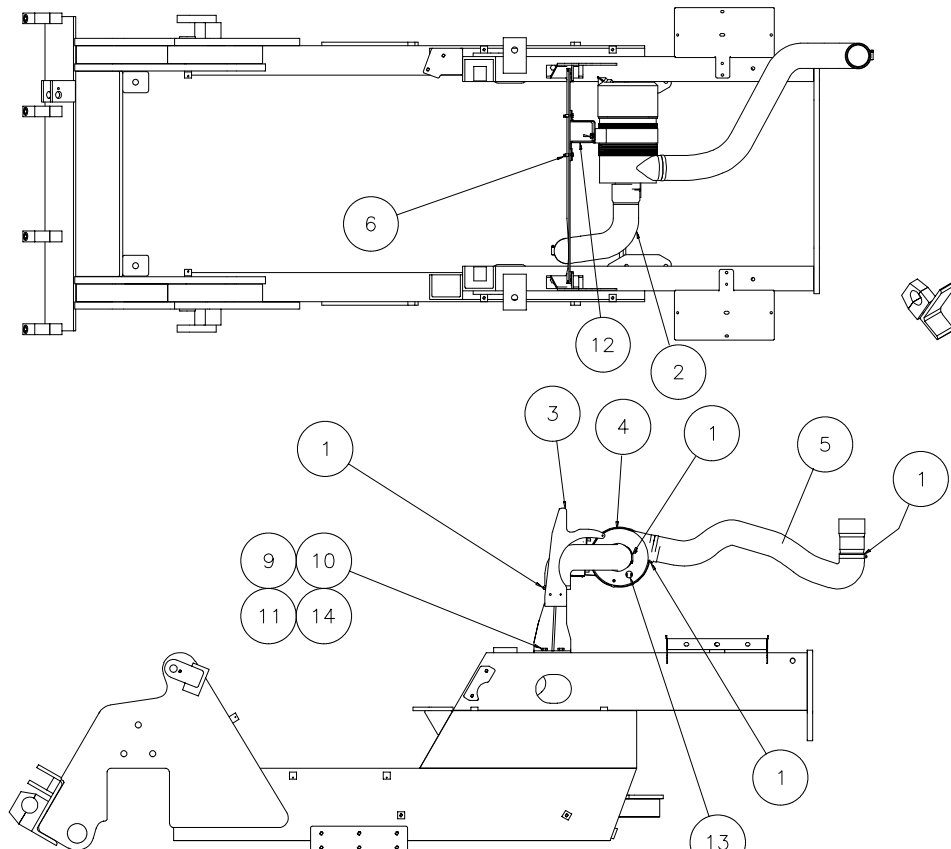

**NELSON AIR CLEANER
(STEEL HOUSING)
- POULTRY ONLY -
S/N: 750480 & ABOVE**

**MANITOU
AIR CLEANER
(PLASTIC HOUSING)**

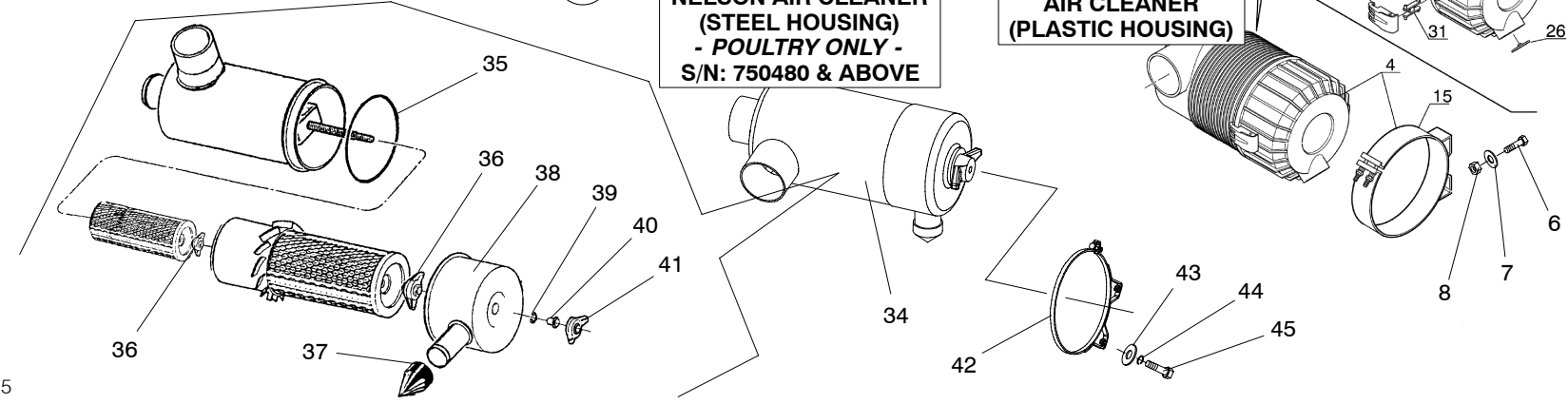

1	AIR INTAKE SYSTEM, INSTALLATION												4 AA 10						
	ITEM	PART NO.	DESCRIPTION	M30-2	M40-2	M50-2	M60-2	M30-2 H	M40-2 H	M50-2 H	M60-2 H	M30-2 L	M40-2 L	M50-2 L	M60-2 L	M30-2 H L	M40-2 H L	M50-2 H L	M60-2 H L
1	229587	Hose clamp	4	4	4	4	4	4	4	4	4	4	4	4	4	4	4	4	4
2	226921	Hose	1	1	1	1	1	1	1	1	1	1	1	1	1	1	1	1	1
3	227076	Bracket, engine bonnet	1	1	1	1	1	1	1	1	1	1	1	1	1	1	1	1	1
4	224711	Filter assembly, complete, Manitou	1	1	1	1	1	1	1	1	1	1	1	1	1	1	1	1	1
5	226807	Hose	1	1	1	1	1	1	1	1	1	1	1	1	1	1	1	1	1
6	42347	Bolt	8	8	8	8	8	8	8	8	8	8	8	8	8	8	8	8	8
7	61674	Washer	8	8	8	8	8	8	8	8	8	8	8	8	8	8	8	8	8
8	58528	Nut	2	2	2	2	2	2	2	2	2	2	2	2	2	2	2	2	2
9	29475	Bolt	4	4	4	4	4	4	4	4	4	4	4	4	4	4	4	4	4
10	42231	Washer	4	4	4	4	4	4	4	4	4	4	4	4	4	4	4	4	4
11	58548	Nut	4	4	4	4	4	4	4	4	4	4	4	4	4	4	4	4	4
12	802333	Bracket, air filter	1	1	1	1	1	1	1	1	1	1	1	1	1	1	1	1	1
13	224776	Air filter clog switch	1	1	1	1	1	1	1	1	1	1	1	1	1	1	1	1	1
14	61676	Washer	4	4	4	4	4	4	4	4	4	4	4	4	4	4	4	4	4
15	224712	Clamp	1	1	1	1	1	1	1	1	1	1	1	1	1	1	1	1	1
25	563487	Cover	1	1	1	1	1	1	1	1	1	1	1	1	1	1	1	1	1
26	563417	Valve	1	1	1	1	1	1	1	1	1	1	1	1	1	1	1	1	1
30	563488	Locker	2	2	2	2	2	2	2	2	2	2	2	2	2	2	2	2	2
31	563489	Rod	2	2	2	2	2	2	2	2	2	2	2	2	2	2	2	2	2
32	803918	Backup ring	1	1	1	1	1	1	1	1	1	1	1	1	1	1	1	1	1
33	803917	Backup ring	1	1	1	1	1	1	1	1	1	1	1	1	1	1	1	1	1
34	804338	Filter assembly, complete, Nelson, S/N: 750480 & ABOVE (POULTRY MODELS ONLY)	1	1	1	1	1	1	1	1	1	1	1	1	1	1	1	1	1
35	426206	O-ring	1	1	1	1	1	1	1	1	1	1	1	1	1	1	1	1	1
36	803653	Wing nut	2	2	2	2	2	2	2	2	2	2	2	2	2	2	2	2	2
37	426203	Dust ejector	1	1	1	1	1	1	1	1	1	1	1	1	1	1	1	1	1
38	803656	Cover, filter housing	1	1	1	1	1	1	1	1	1	1	1	1	1	1	1	1	1
39	426197	E-ring	1	1	1	1	1	1	1	1	1	1	1	1	1	1	1	1	1
40	426196	Washer	1	1	1	1	1	1	1	1	1	1	1	1	1	1	1	1	1
41	426198	Wing nut	1	1	1	1	1	1	1	1	1	1	1	1	1	1	1	1	1

EXHAUST SYSTEM ASSEMBLY

M30-2	M30-4	M30-2 H	M30-4 H
M40-2	M40-4	M40-2 H	M40-4 H
M50-2	M50-4	M50-2 H	M50-4 H
M60-2	M60-4	M60-2 H	M60-4 H
M30-2 L	M30-4 L	M30-2 H L	M30-4 H L
M40-2 L	M40-4 L	M40-2 H L	M40-4 H L
M50-2 L	M50-4 L	M50-2 H L	M50-4 H L
M60-2 L	M60-4 L	M60-2 H L	M60-4 H L

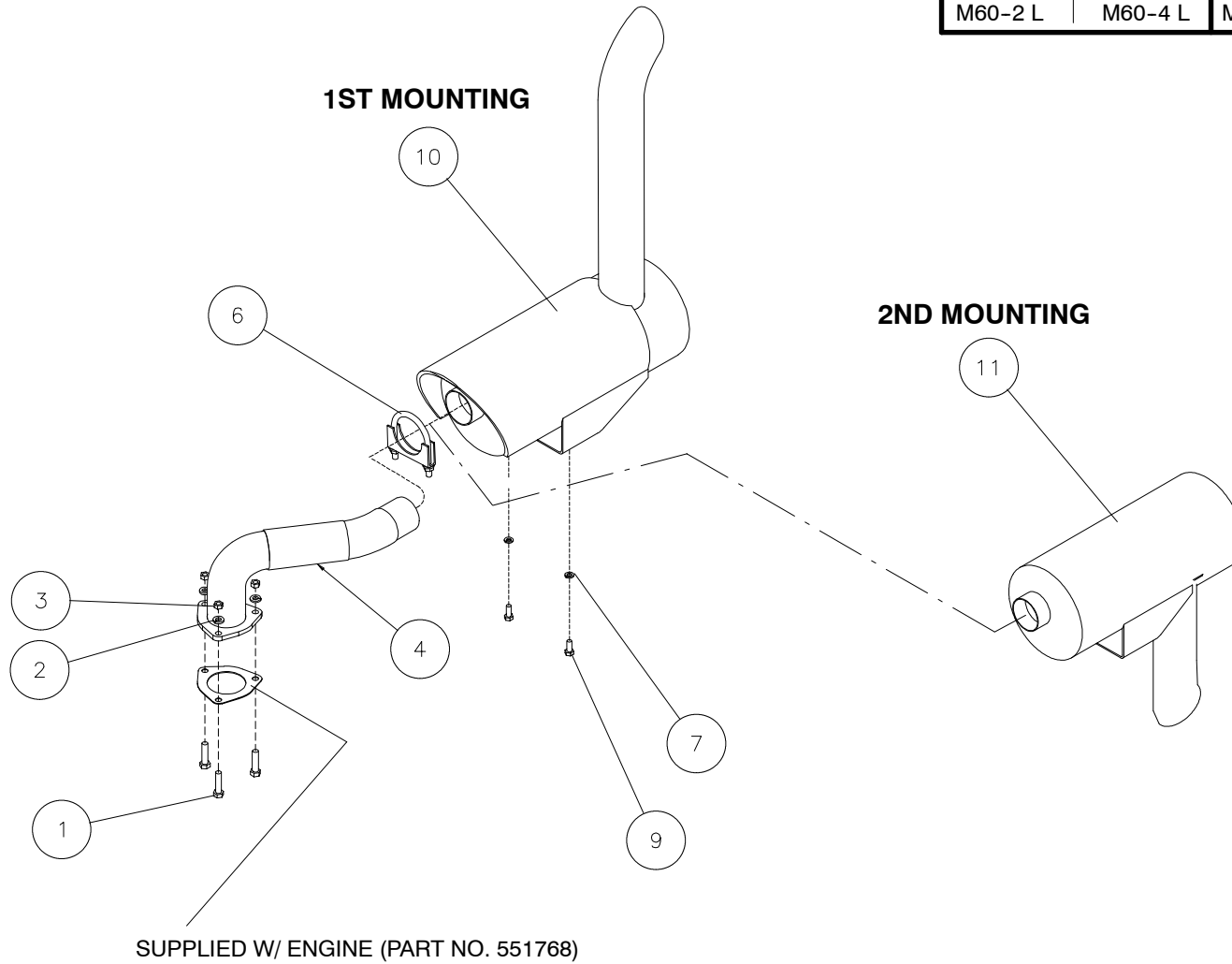

1	EXHAUST SYSTEM ASSEMBLY												QUANTITY / MODEL				4 AA 20			
	ITEM	PART NO.	DESCRIPTION	M30-2	M40-2	M50-2	M60-2	M30-2 H	M40-2 H	M50-2 H	M60-2 H	M30-2 L	M40-2 L	M50-2 L	M60-2 L	M30-2 H L	M40-2 H L	M50-2 H L	M60-2 H L	
1	KN605803	Bolt		3	3	3	3	3	3	3	3	3	3	3	3	3	3	3	3	
2	42232	Washer		3	3	3	3	3	3	3	3	3	3	3	3	3	3	3	3	
3	56354	Nut		3	3	3	3	3	3	3	3	3	3	3	3	3	3	3	3	
4A	804095	Exhaust tube (S/N: 750173, 750171 & below)		1	1	1	1	1	1	1	1	1	1	1	1	1	1	1	1	
4B	804070	Exhaust tube (S/N: 750172 & above, except 750173)		1	1	1	1	1	1	1	1	1	1	1	1	1	1	1	1	
6	423625	Clamp		1	1	1	1	1	1	1	1	1	1	1	1	1	1	1	1	
7	42325	Washer		2	2	2	2	2	2	2	2	2	2	2	2	2	2	2	2	
8	----	Omitted																		
9	42347	Bolt		2	2	2	2	2	2	2	2	2	2	2	2	2	2	2	2	
10	234196	Muffler w/ stack (S/N: 750173, 750171 & below)		1	1	1	1	1	1	1	1	1	1	1	1	1	1	1	1	
11A	803501	Muffler, exhaust down (S/N: 750172 & above, except 750173)		1	1	1	1	1	1	1	1	1	1	1	1	1	1	1	1	
11B	803529	Muffler, exhaust down, catalytic (Perkins only) (S/N: 750172 & above, except 750173)		1	1	1	1	1	1	1	1	1	1	1	1	1	1	1	1	

4 AA 30

RADIATOR INSTALLATION

M30-2	M30-4	M30-2 H	M30-4 H
M40-2	M40-4	M40-2 H	M40-4 H
M50-2	M50-4	M50-2 H	M50-4 H
M60-2	M60-4	M60-2 H	M60-4 H
M30-2 L	M30-4 L	M30-2 H L	M30-4 H L
M40-2 L	M40-4 L	M40-2 H L	M40-4 H L
M50-2 L	M50-4 L	M50-2 H L	M50-4 H L
M60-2 L	M60-4 L	M60-2 H L	M60-4 H L

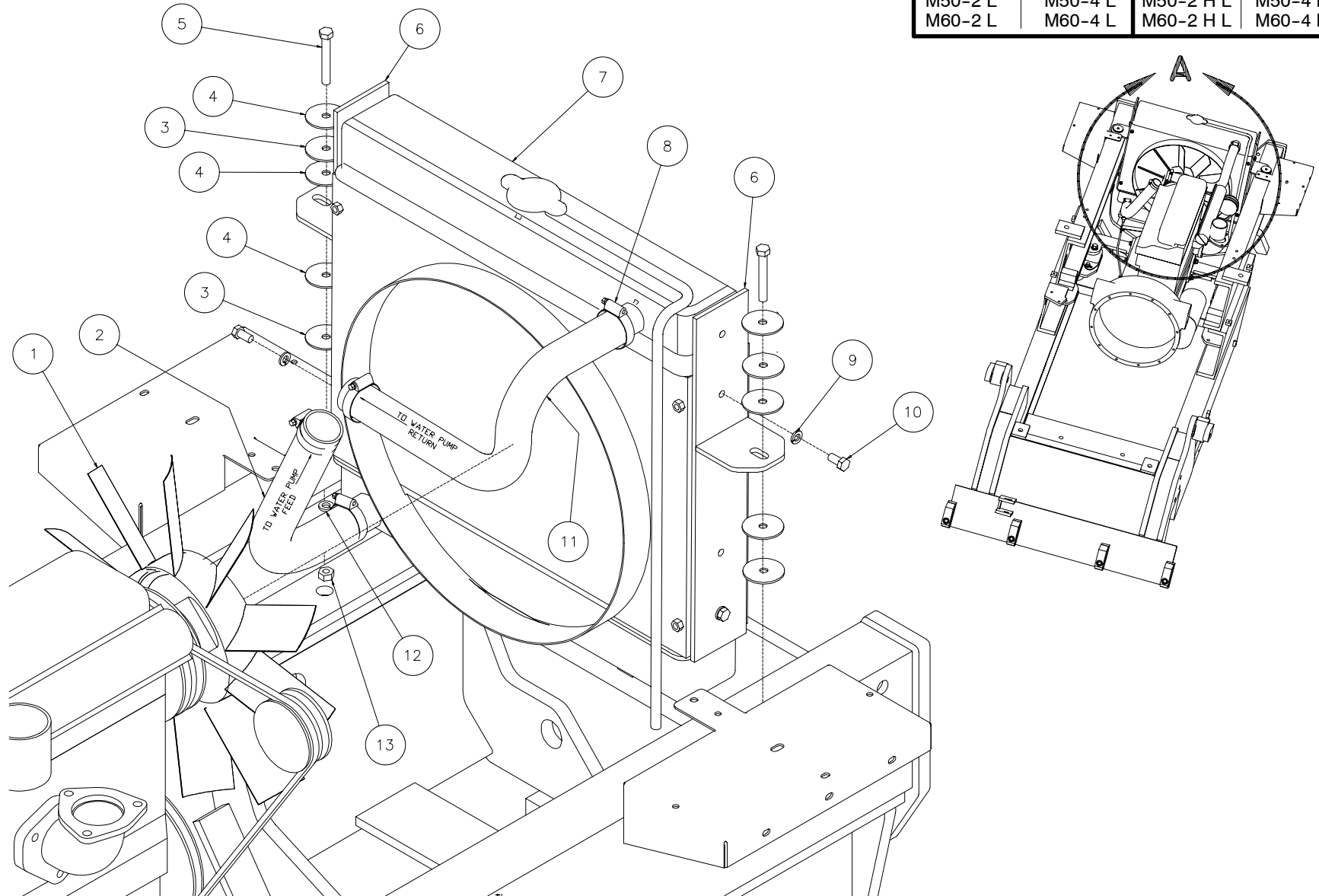

VIEW A

1	RADIATOR INSTALLATION												4 AA 30						
	ITEM	PART NO.	DESCRIPTION	M30-2	M40-2	M50-2	M60-2	M30-2 H	M40-2 H	M50-2 H	M60-2 H	M30-2 L	M40-2 L	M50-2 L	M60-2 L	M30-2 H L	M40-2 H L	M50-2 H L	M60-2 H L
1	----	Fan - See AP2054	1	1	1	1	1	1	1	1	1	1	1	1	1	1	1	1	1
2	493729	Hose, lower	1	1	1	1	1	1	1	1	1	1	1	1	1	1	1	1	1
3	73979	Rubber washer	4	4	4	4	4	4	4	4	4	4	4	4	4	4	4	4	4
4	36010	Washer	6	6	6	6	6	6	6	6	6	6	6	6	6	6	6	6	6
5	58538	Bolt	2	2	2	2	2	2	2	2	2	2	2	2	2	2	2	2	2
6	802491	Radiator bracket	2	2	2	2	2	2	2	2	2	2	2	2	2	2	2	2	2
7	802498	Radiator, complete	1	1	1	1	1	1	1	1	1	1	1	1	1	1	1	1	1
8	B2236-8	Hose clamp	4	4	4	4	4	4	4	4	4	4	4	4	4	4	4	4	4
9	K34807	Washer	4	4	4	4	4	4	4	4	4	4	4	4	4	4	4	4	4
10	K20348	Bolt	4	4	4	4	4	4	4	4	4	4	4	4	4	4	4	4	4
11	226426	Hose, upper	1	1	1	1	1	1	1	1	1	1	1	1	1	1	1	1	1
12	42232	Washer	2	2	2	2	2	2	2	2	2	2	2	2	2	2	2	2	2
13	56354	Nut	2	2	2	2	2	2	2	2	2	2	2	2	2	2	2	2	2

4 AA 31

RADIATOR COOLING TRAY

M30-2	M30-4	M30-2 H	M30-4 H
M40-2	M40-4	M40-2 H	M40-4 H
M50-2	M50-4	M50-2 H	M50-4 H
M60-2	M60-4	M60-2 H	M60-4 H
M30-2 L	M30-4 L	M30-2 H L	M30-4 H L
M40-2 L	M40-4 L	M40-2 H L	M40-4 H L
M50-2 L	M50-4 L	M50-2 H L	M50-4 H L
M60-2 L	M60-4 L	M60-2 H L	M60-4 H L

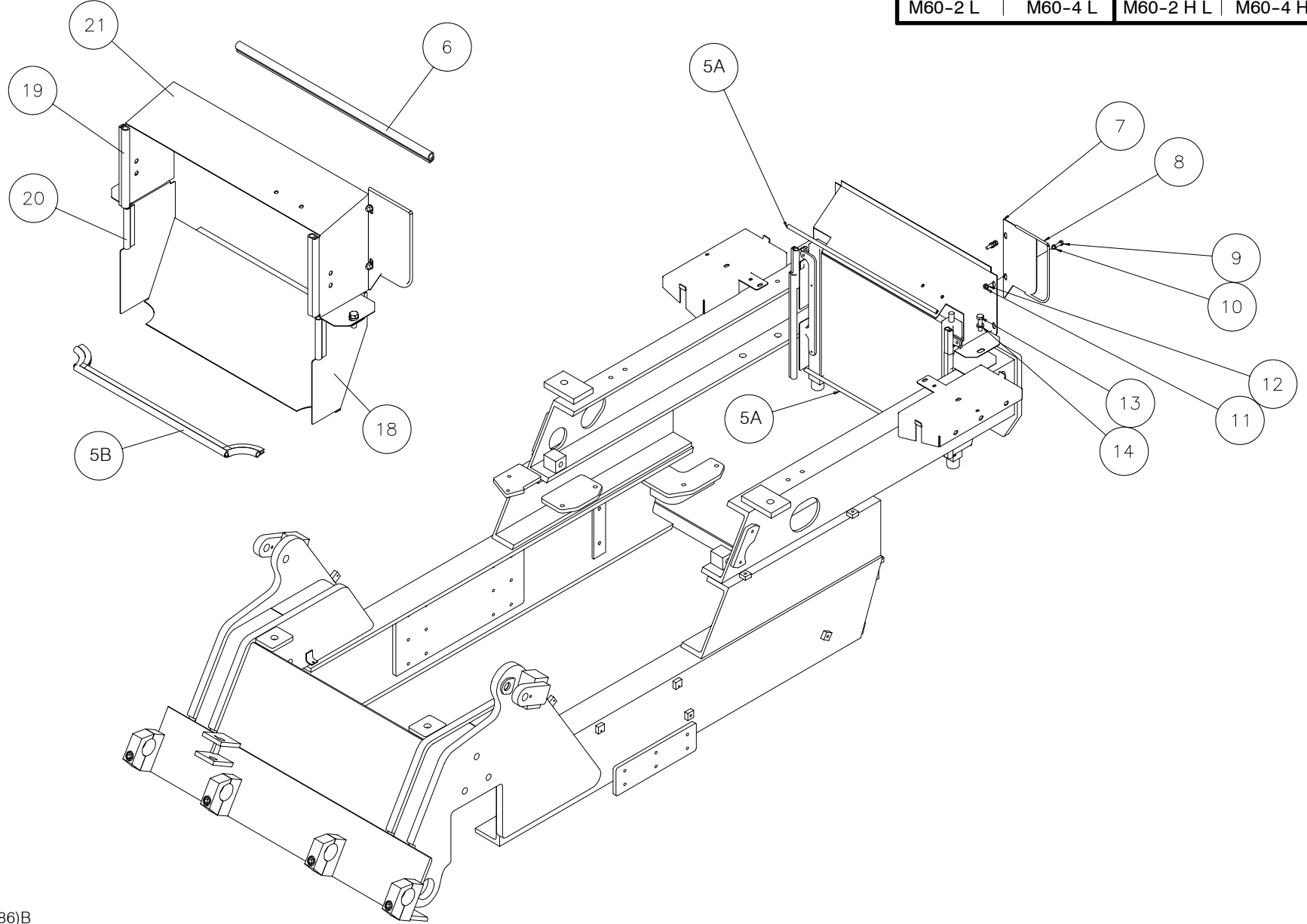

1	RADIATOR COOLING TRAY		QUANTITY / MODEL												4 AA 31			
			M30-4	M40-4	M50-4	M60-4	M30-4 H	M40-4 H	M50-4 H	M60-4 H	M30-4 L	M40-4 L	M50-4 L	M60-4 L	M30-4 H L	M40-4 H L	M50-4 H L	M60-4 H L
ITEM	PART NO.	DESCRIPTION	M30-2	M40-2	M50-2	M60-2	M30-2 H	M40-2 H	M50-2 H	M60-2 H	M30-2 L	M40-2 L	M50-2 L	M60-2 L	M30-2 H L	M40-2 H L	M50-2 H L	M60-2 H L
5A*	802036	Weather strip	2	2	2	2	2	2	2	2	2	2	2	2	2	2	2	2
5B**	Z4054-27.63	Weather strip	1	1	1	1	1	1	1	1	1	1	1	1	1	1	1	1
6	802889	Weather strip	1	1	1	1	1	1	1	1	1	1	1	1	1	1	1	1
7	802885	Plate	1	1	1	1	1	1	1	1	1	1	1	1	1	1	1	1
8	802887	Weather strip	1	1	1	1	1	1	1	1	1	1	1	1	1	1	1	1
9	42347	Bolt	2	2	2	2	2	2	2	2	2	2	2	2	2	2	2	2
10	42325	Washer, lock	2	2	2	2	2	2	2	2	2	2	2	2	2	2	2	2
11	58528	Nut	2	2	2	2	2	2	2	2	2	2	2	2	2	2	2	2
12	61674	Washer, flat	2	2	2	2	2	2	2	2	2	2	2	2	2	2	2	2
13	63547	Bolt	2	2	2	2	2	2	2	2	2	2	2	2	2	2	2	2
14	42231	Washer, lock	2	2	2	2	2	2	2	2	2	2	2	2	2	2	2	2
18A*	802765	Cooler tray, bottom	1	1	1	1	1	1	1	1	1	1	1	1	1	1	1	1
18B**	804019	Cooler tray, bottom	1	1	1	1	1	1	1	1	1	1	1	1	1	1	1	1
19	802892	Weather strip	2	2	2	2	2	2	2	2	2	2	2	2	2	2	2	2
20A*	802893	Weather strip	2	2	2	2	2	2	2	2	2	2	2	2	2	2	2	2
20B**	Z4054-4.5	Weather strip	2	2	2	2	2	2	2	2	2	2	2	2	2	2	2	2
21A*	803012	Cooler tray, top	1	1	1	1	1	1	1	1	1	1	1	1	1	1	1	1
21B**	804023	Cooler tray, top	1	1	1	1	1	1	1	1	1	1	1	1	1	1	1	1

* Item used on S/N: 750182 & below
** Item used on S/N: 750183 & above

4 AA 40

ENGINE MOUNTING

M30-2	M30-4	M30-2 H	M30-4 H
M40-2	M40-4	M40-2 H	M40-4 H
M50-2	M50-4	M50-2 H	M50-4 H
M60-2	M60-4	M60-2 H	M60-4 H
M30-2 L	M30-4 L	M30-2 H L	M30-4 H L
M40-2 L	M40-4 L	M40-2 H L	M40-4 H L
M50-2 L	M50-4 L	M50-2 H L	M50-4 H L
M60-2 L	M60-4 L	M60-2 H L	M60-4 H L

FOR ENGINE INFO SEE AP2054

NOTE:
APPLY LOCTITE 242 (BLUE) TO THREADS
OF BOLT DURING INSTALLATION.

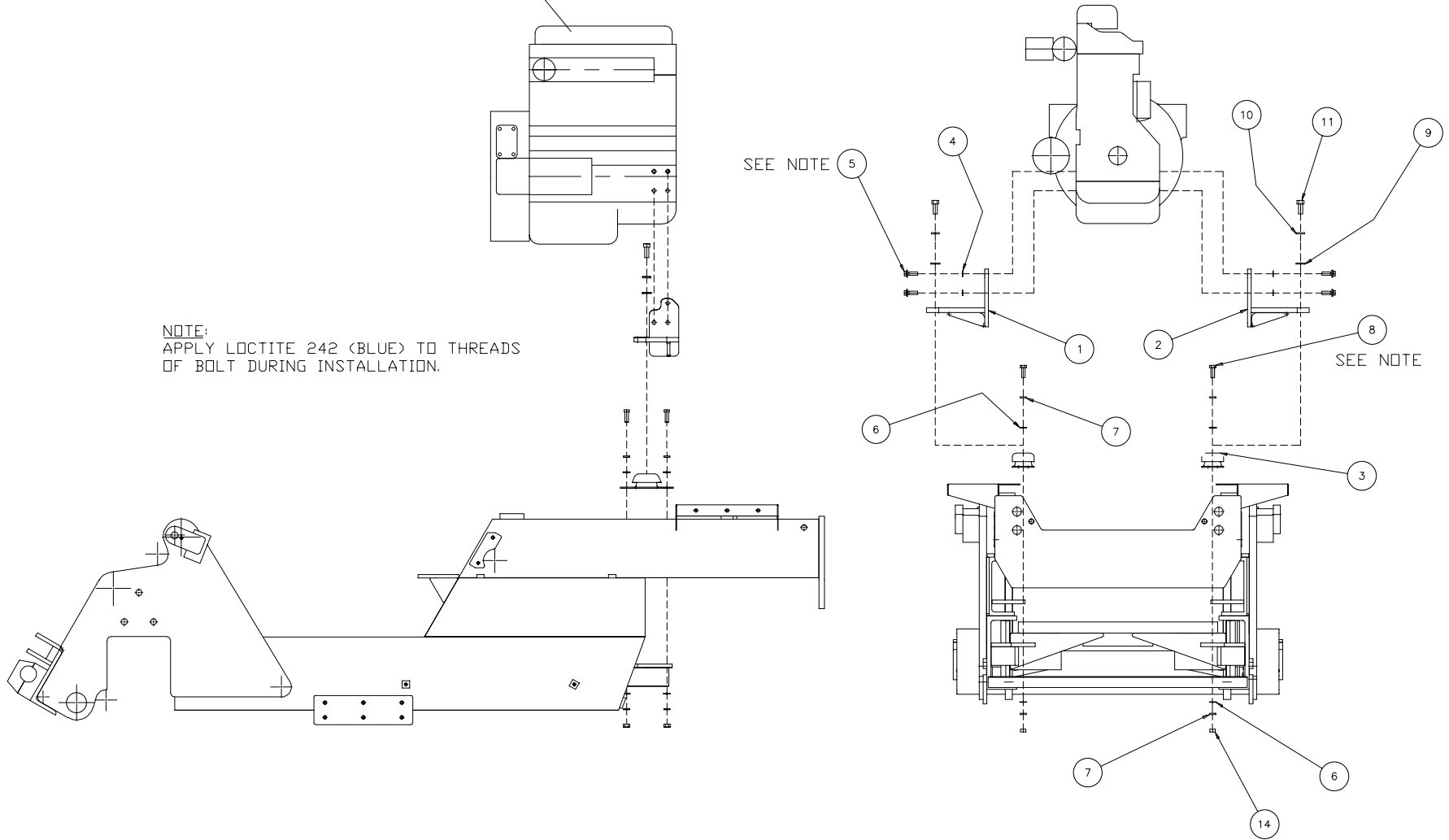

1	ENGINE MOUNTING												4 AA 40						
	ITEM	PART NO.	DESCRIPTION	M30-2	M40-2	M50-2	M60-2	M30-2 H	M40-2 H	M50-2 H	M60-2 H	M30-2 L	M40-2 L	M50-2 L	M60-2 L	M30-2 H L	M40-2 H L	M50-2 H L	M60-2 H L
1	801950	Engine mount, rear LH	1	1	1	1	1	1	1	1	1	1	1	1	1	1	1	1	1
2	801949	Engine mount, rear RH	1	1	1	1	1	1	1	1	1	1	1	1	1	1	1	1	1
3	227128	Shock mount	2	2	2	2	2	2	2	2	2	2	2	2	2	2	2	2	2
4	KN630360	Washer	6	6	6	6	6	6	6	6	6	6	6	6	6	6	6	6	6
5	KN605815	Bolt	6	6	6	6	6	6	6	6	6	6	6	6	6	6	6	6	6
6	61676	Washer	8	8	8	8	8	8	8	8	8	8	8	8	8	8	8	8	8
7	42231	Washer	8	8	8	8	8	8	8	8	8	8	8	8	8	8	8	8	8
8	58546	Bolt	4	4	4	4	4	4	4	4	4	4	4	4	4	4	4	4	4
9	62203	Washer	2	2	2	2	2	2	2	2	2	2	2	2	2	2	2	2	2
10	42322	Washer	2	2	2	2	2	2	2	2	2	2	2	2	2	2	2	2	2
11	58588	Bolt	2	2	2	2	2	2	2	2	2	2	2	2	2	2	2	2	2
12	----	Omitted																	
13	----	Omitted																	
14	58548	Nut	4	4	4	4	4	4	4	4	4	4	4	4	4	4	4	4	4

4 AA 50

TRANSMISSION INSTALLATION, 4-SPEED (2WD & 4WD)

M30-2	M30-4		
M40-2	M40-4		
M50-2	M50-4		
M60-2	M60-4		
M30-2 L	M30-4 L		
M40-2 L	M40-4 L		
M50-2 L	M50-4 L		
M60-2 L	M60-4 L		

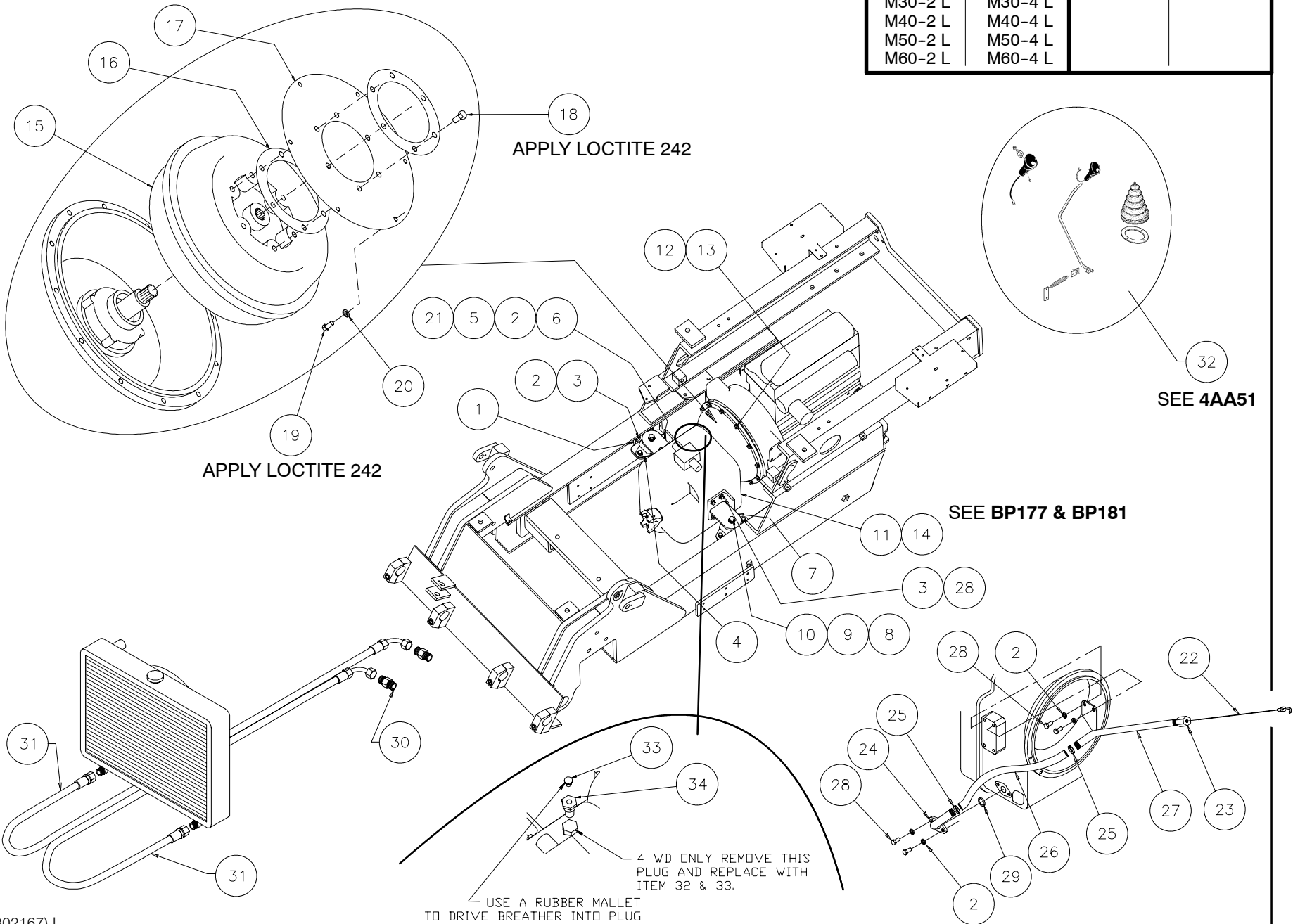

1	TRANSMISSION INSTALLATION, 4-SPEED (2WD & 4WD)		QUANTITY / MODEL											4 AA 50					
			M30-4	M40-4	M50-4	M60-4					M30-4 L	M40-4 L	M50-4 L	M60-4 L					
ITEM	PART NO.	DESCRIPTION	M30-2	M40-2	M50-2	M60-2						M30-2 L	M40-2 L	M50-2 L	M60-2 L				
1	801820	Transmission mount, lower	2	2	2	2						2	2	2	2				
2	42231	Washer	16	16	16	16						16	16	16	16				
3	58546	Bolt	16	16	16	16						16	16	16	16				
4	227128	Motor mount, rubber	2	2	2	2						2	2	2	2				
5	61676	Washer	12	12	12	12						12	12	12	12				
6	29475	Bolt	4	4	4	4						4	4	4	4				
7	801822	Transmission mount, upper	2	2	2	2						2	2	2	2				
8	62203	Washer	2	2	2	2						2	2	2	2				
9	42322	Washer	2	2	2	2						2	2	2	2				
10	58588	Bolt	2	2	2	2						2	2	2	2				
11	222573	Transmission, 4WD (ALL 4-SPEED, 4WD MODELS)																	
12	KN630174	Washer	12	12	12	12						12	12	12	12				
13	KN605803	Bolt	12	12	12	12						12	12	12	12				
14	222572	Transmission, 2WD (ALL 4-SPEED, 2WD MODELS)																	
15	209372	Torque converter	1	1	1	1						1	1	1	1				
16	209374	Re-inforcing plate	2	2	2	2						2	2	2	2				
17	209373	Flex drive plate	1	1	1	1						1	1	1	1				
18	209376	Bolt	6	6	6	6						6	6	6	6				
19	209375	Bolt	6	6	6	6						6	6	6	6				
20	209573	Washer	6	6	6	6						6	6	6	6				
21	58548	Nut	4	4	4	4						4	4	4	4				
22	219464	Dipstick, transmission	1	1	1	1						1	1	1	1				
23	205785	Fitting	1	1	1	1						1	1	1	1				
24	219432	Tube, weldment	1	1	1	1						1	1	1	1				
25	71940	Hose clamp	2	2	2	2						2	2	2	2				
26	802934	Hose	1	1	1	1						1	1	1	1				
27	232998	Tube, bent	1	1	1	1						1	1	1	1				
28	44807	Bolt	4	4	4	4						4	4	4	4				

2	TRANSMISSION INSTALLATION, 4-SPEED (2WD & 4WD)		QUANTITY / MODEL										4 AA 50					
			M30-4	M40-4	M50-4	M60-4					M30-4 L	M40-4 L	M50-4 L	M60-4 L				
ITEM	PART NO.	DESCRIPTION	M30-2	M40-2	M50-2	M60-2					M30-2 L	M40-2 L	M50-2 L	M60-2 L				
29	4039	O-ring	1	1	1	1					1	1	1	1				
30	R18147-5	Adapter	2	2	2	2					2	2	2	2				
31	802753	Hose	2	2	2	2					2	2	2	2				
32	802761	Gear lever assembly	1	1	1	1					1	1	1	1				
33	109705	Breather	1	1	1	1					1	1	1	1				
34	246347	Plug	1	1	1	1					1	1	1	1				

4 AA 51

GEAR LEVER ASSEMBLY, 4-SPEED TRANSMISSION, 2WD & 4WD

M30-2	M30-4		
M40-2	M40-4		
M50-2	M50-4		
M60-2	M60-4		
M30-2 L	M30-4 L		
M40-2 L	M40-4 L		
M50-2 L	M50-4 L		
M60-2 L	M60-4 L		

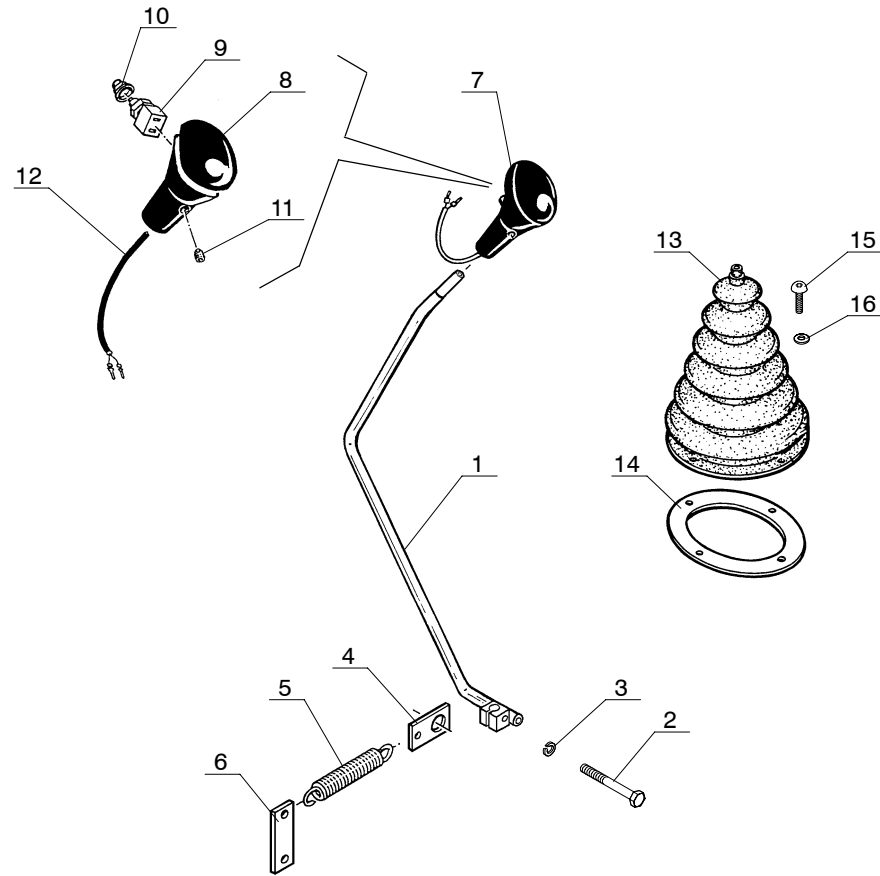

1	GEAR LEVER ASSEMBLY, 4-SPEED TRANSMISSION, 2WD & 4WD		QUANTITY / MODEL								4 AA 51			
			M30-4	M40-4	M50-4	M60-4					M30-4 L	M40-4 L	M50-4 L	M60-4 L
ITEM	PART NO.	DESCRIPTION	M30-2	M40-2	M50-2	M60-2					M30-2 L	M40-2 L	M50-2 L	M60-2 L
	803388	Gear lever assembly (77 in. & 81 in. cab)	1	1	1	1					1	1	1	1
	802761	Gear lever assembly (100 in. cab only)	1	1	1	1					1	1	1	1
1A	803388	Lever, (77 in. & 81 in. cab)	1	1	1	1					1	1	1	1
1B	802762	Lever, (100 in. cab only)	1	1	1	1					1	1	1	1
2	29475	Screw	1	1	1	1					1	1	1	1
3	42231	Washer	1	1	1	1					1	1	1	1
4	78086	Fixing spring	1	1	1	1					1	1	1	1
5	80308	Spring	1	1	1	1					1	1	1	1
6	164965	Fastening plate	1	1	1	1					1	1	1	1
7	211278	Ball assembly	1	1	1	1					1	1	1	1
8	551255	Cap	1	1	1	1					1	1	1	1
9	551256	Switch, trans cut-off	1	1	1	1					1	1	1	1
10	551258	Cap	1	1	1	1					1	1	1	1
11	551257	Screw	1	1	1	1					1	1	1	1
12	551259	Wire harness	1	1	1	1					1	1	1	1
13	78088	Bellows	1	1	1	1					1	1	1	1
14	803875	Fastening plate	1	1	1	1					1	1	1	1
15	189172	Screw	4	4	4	4					4	4	4	4
16	189857	Washer	4	4	4	4					4	4	4	4

4 AB 10

S/N: 181964 TO 181999 HYDROSTATIC (TRANSMISSION) SYSTEM ASSEMBLY, 1ST MOUNTING

M30-2 H	M30-4 H
M40-2 H	M40-4 H
M50-2 H	M50-4 H
M60-2 H	M60-4 H
M30-2 H L	M30-4 H L
M40-2 H L	M40-4 H L
M50-2 H L	M50-4 H L
M60-2 H L	M60-4 H L

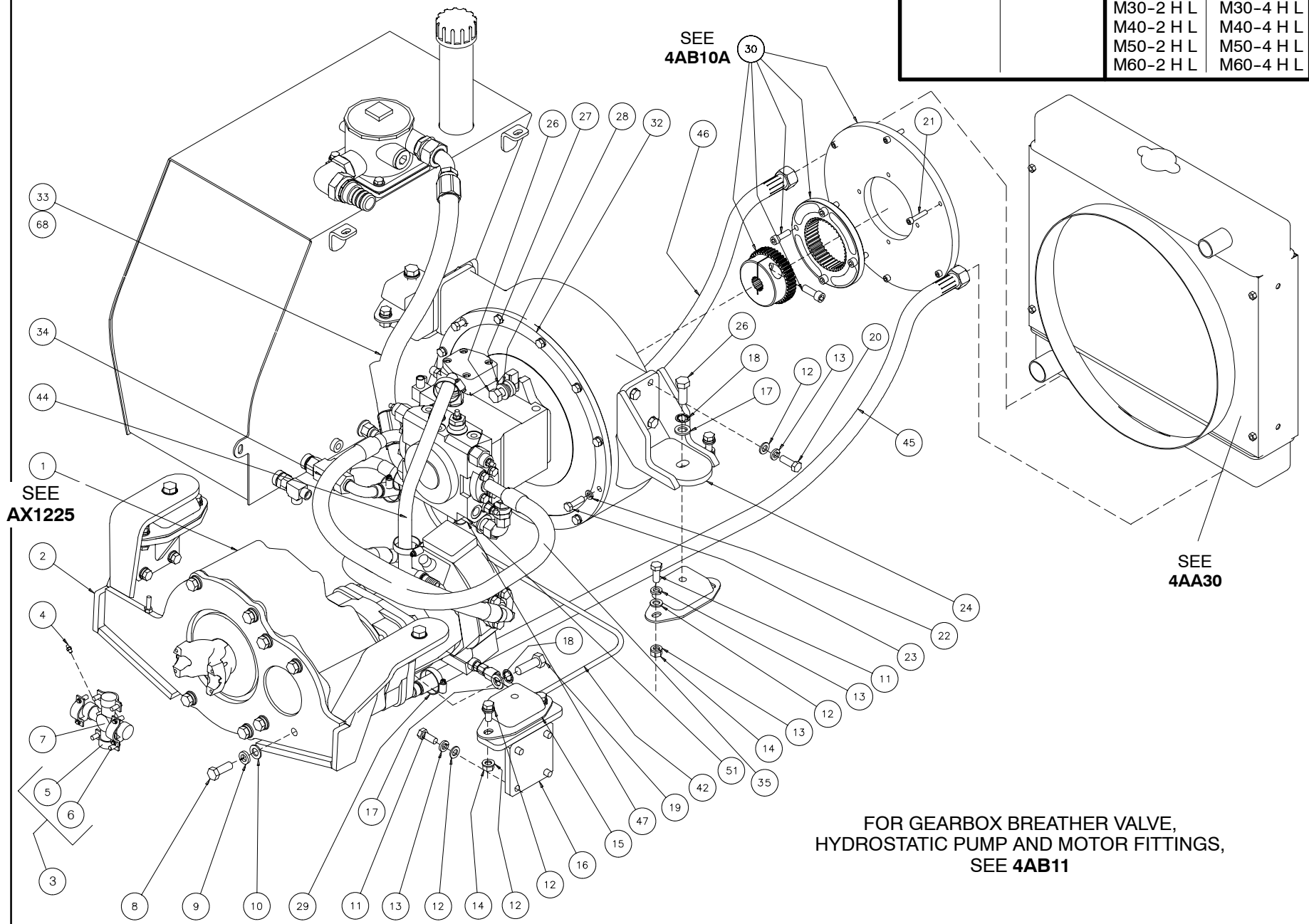

FOR GEARBOX BREATHER VALVE,
HYDROSTATIC PUMP AND MOTOR FITTINGS,
SEE 4AB11

1	S/N: 181964 TO 181999 HYDROSTATIC (TRANSMISSION) SYSTEM ASSEMBLY, 1ST MOUNTING		QUANTITY / MODEL								4 AB 10							
											M30-4 H	M40-4 H	M50-4 H	M60-4 H	M30-4 H L	M40-4 H L	M50-4 H L	M60-4 H L
											M30-2 H	M40-2 H	M50-2 H	M60-2 H	M30-2 H L	M40-2 H L	M50-2 H L	M60-2 H L
ITEM	PART NO.	DESCRIPTION																
1	801992	Gearbox assembly, 6 & 8 K				1	1							1	1			
1	226148	Gearbox assembly, 10 & 12 K														1	1	
2	802120	Gear box mount (NO FRAME LEVELING)				1	1	1	1									
2	803205	Gear box mount (FRAME LEVELING MODELS)												1	1	1	1	
3	425330	Strap and bolt kit (2 straps, 4 bolts)				2	2	2	2					2	2	2	2	
4	162809	Grease fitting				1	1	1	1					1	1	1	1	
5	109751	Clamp half				4	4	4	4					4	4	4	4	
6	109752	Bolt				8	8	8	8					8	8	8	8	
7	424647	Crossblock, universal joint (Includes Item 4)				1	1	1	1					1	1	1	1	
8	58557	Bolt				8	8	8	8					8	8	8	8	
9	42256	Washer				8	8	8	8					8	8	8	8	
10	61680	Washer				8	8	8	8					8	8	8	8	
11	63547	Bolt				16	16	16	16					16	16	16	16	
12	61676	Washer				32	32	32	32					32	32	32	32	
13	42231	Washer				32	32	32	32					32	32	32	32	
14	58548	Nut				8	8	8	8					8	8	8	8	
15	227128	Shock mount				4	4	4	4					4	4	4	4	
16	802292	Mount, gear box				2	2	2	2					2	2	2	2	
17	KN630091	Washer				8	8	8	8					8	8	8	8	
18	KN630361	Washer				8	8	8	8					8	8	8	8	
19	61308	Bolt				4	4	4	4					4	4	4	4	
20	58546	Bolt				8	8	8	8					8	8	8	8	
21	K302256	Screw				6	6	6	6					6	6	6	6	
22	42232	Washer				12	12	12	12					12	12	12	12	
23	168351	Bolt				12	12	12	12					12	12	12	12	
24	801943	Mount, flywheel				2	2	2	2					2	2	2	2	
25	----	deleted																

2	S/N: 181964 TO 181999 HYDROSTATIC (TRANSMISSION) SYSTEM ASSEMBLY, 1ST MOUNTING		QUANTITY / MODEL								4 AB 10						
											M30-4 H L	M40-4 H L	M50-4 H L	M60-4 H L			
											M30-2 H L	M40-2 H L	M50-2 H L	M60-2 H L			
ITEM	PART NO.	DESCRIPTION															
26	42818	Bolt				6	6	6	6					6	6	6	6
27	62203	Washer				2	2	2	2					2	2	2	2
28	42322	Washer				2	2	2	2					2	2	2	2
29	203512	Clamp				8	8	8	8					8	8	8	8
30	801829	Hydrostatic coupling (less Item 21)				1	1	1	1					1	1	1	1
31	- - - -	deleted															
32	508802	Plate, pump mounting				1	1	1	1					1	1	1	1
33	803271	Hose assembly, hydrostatic supply				1	1	1	1					1	1	1	1
34	803483	Hose assembly, pump to motor				1	1	1	1					1	1	1	1
35	496725	Hose assembly, pump to motor				1	1	1	1					1	1	1	1
36	- - - -	deleted															
37	- - - -	deleted															
38	- - - -	deleted															
39	- - - -	deleted															
40	- - - -	deleted															
41	- - - -	deleted															
42	803275	Hose assembly, pump 'x1' - motor 'x2'				2	2	2	2					2	2	2	2
43	- - - -	deleted															
44	802898	Hose, pump 't' - motor 't'				1	1	1	1					1	1	1	1
45	803455	Hose, hydraulic motor to radiator				1	1	1	1					1	1	1	1
46	803454	Hose, hydraulic tank to radiator				1	1	1	1					1	1	1	1
47	802897	Hose, pump "T" to tank				1	1	1	1					1	1	1	1
68	Z4525-5	Sleeve, hose x 5 in.				1	1	1	1					1	1	1	1

4 AB 10.1

S/N: 182000 TO 750156
HYDROSTATIC (TRANSMISSION) SYSTEM ASSEMBLY,
2ND MOUNTING

M30-2 H	M30-4 H
M40-2 H	M40-4 H
M50-2 H	M50-4 H
M60-2 H	M60-4 H
M30-2 H L	M30-4 H L
M40-2 H L	M40-4 H L
M50-2 H L	M50-4 H L
M60-2 H L	M60-4 H L

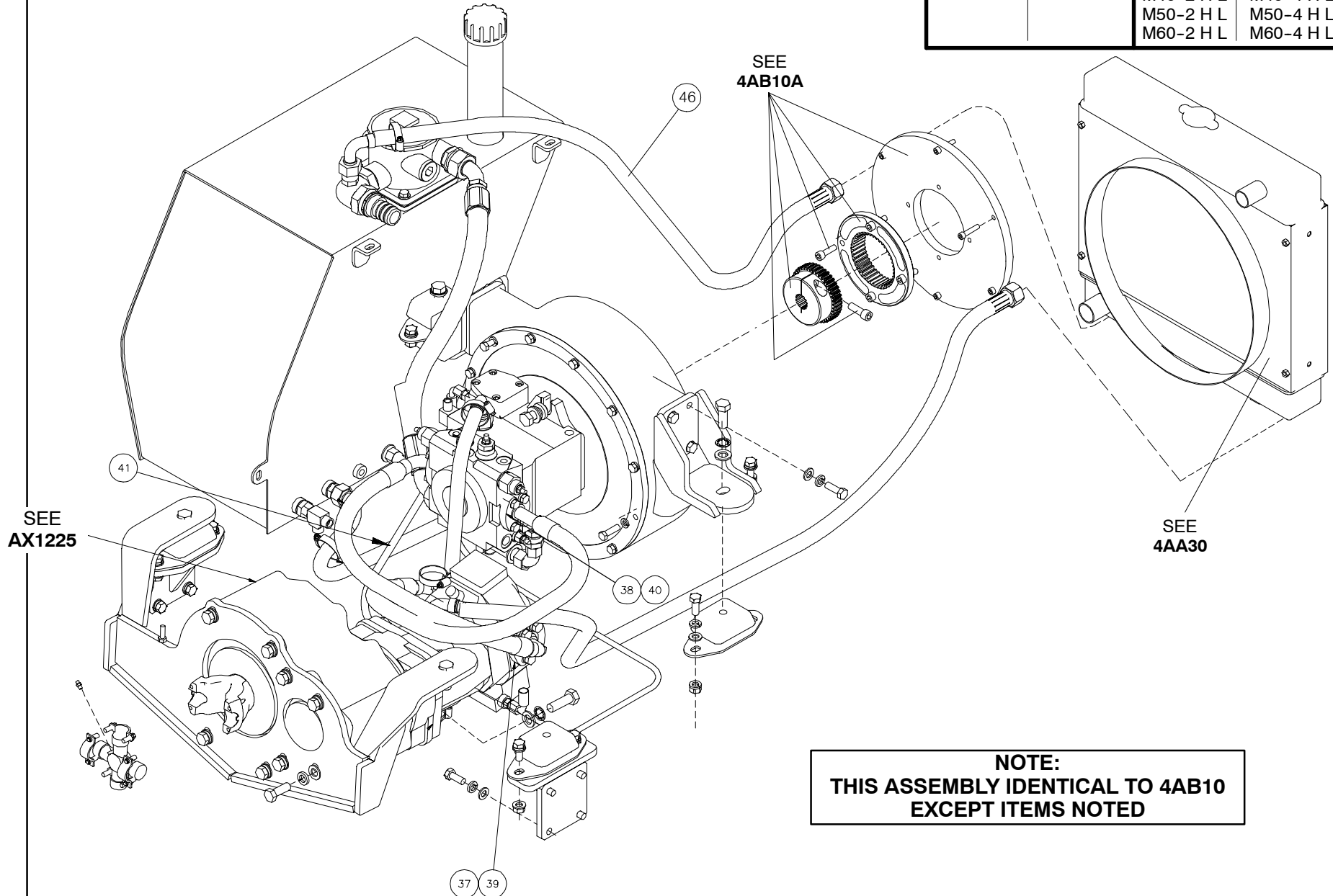

1	S/N: 181964 TO 181999 HYDROSTATIC (TRANSMISSION) SYSTEM ASSEMBLY, 2ND MOUNTING		QUANTITY / MODEL								4 AB 10.1							
							M30-4 H	M40-4 H	M50-4 H	M60-4 H					M30-4 H L	M40-4 H L	M50-4 H L	M60-4 H L
ITEM	PART NO.	DESCRIPTION					M30-2 H	M40-2 H	M50-2 H	M60-2 H					M30-2 H L	M40-2 H L	M50-2 H L	M60-2 H L
37	803611	O-ring					2	2	2	2					2	2	2	2
38	803566	Split flange -12					4	4	4	4					4	4	4	4
39	803570	Split flange -16					4	4	4	4					4	4	4	4
40	803585	O-ring					2	2	2	2					2	2	2	2
41	803274	Hose assembly, pump x2 to motor x2					1	1	1	1					1	1	1	1
46	803454	Hose assembly, hydraulic tank to radiator					1	1	1	1					1	1	1	1

4 AB 10.2

S/N: 750157 & ABOVE HYDROSTATIC (TRANSMISSION) SYSTEM ASSEMBLY, 3RD MOUNTING

M30-2 H	M30-4 H
M40-2 H	M40-4 H
M50-2 H	M50-4 H
M60-2 H	M60-4 H
M30-2 H L	M30-4 H L
M40-2 H L	M40-4 H L
M50-2 H L	M50-4 H L
M60-2 H L	M60-4 H L

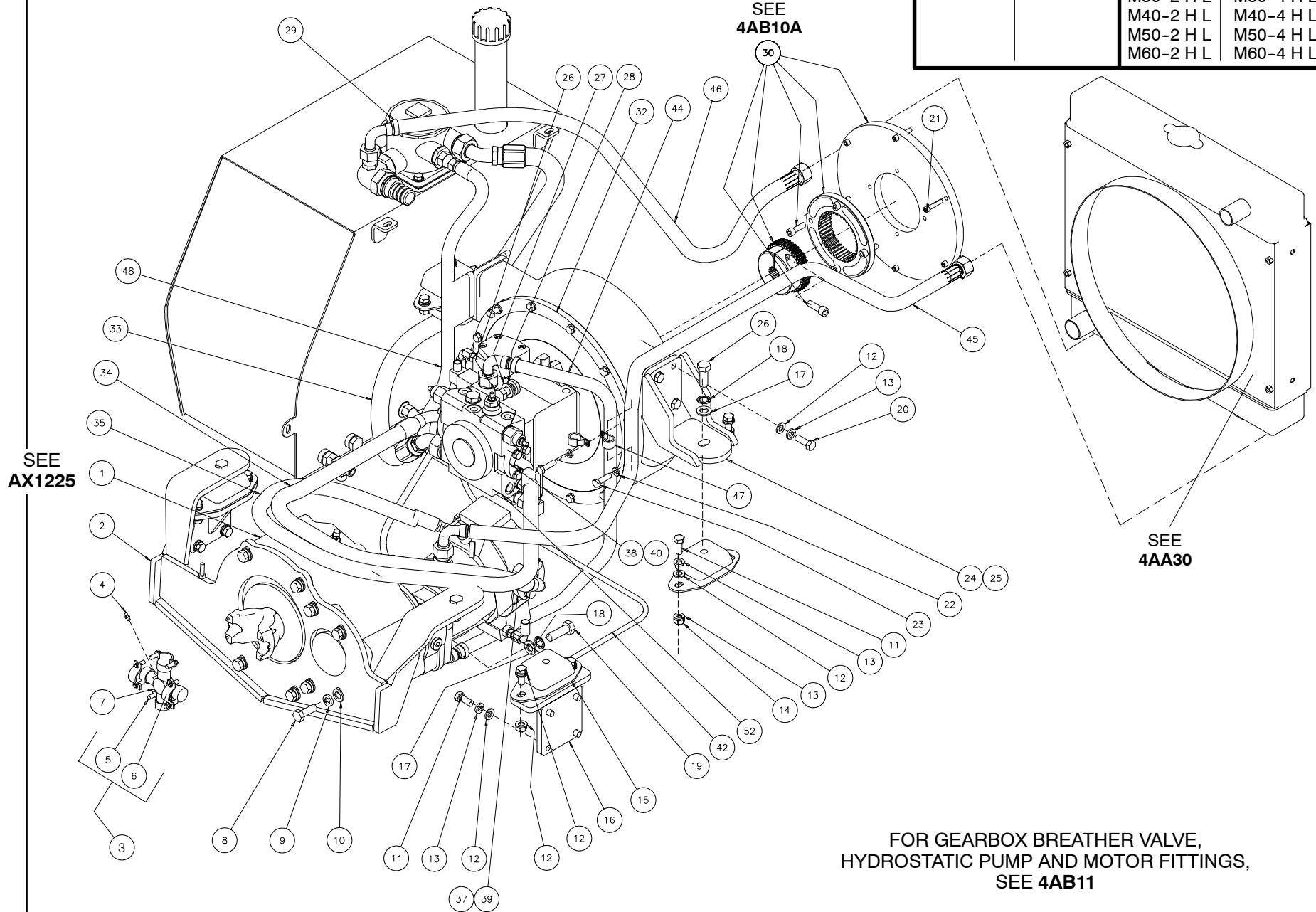

1	S/N: 750157 & ABOVE HYDROSTATIC (TRANSMISSION) SYSTEM ASSEMBLY, 3RD MOUNTING		QUANTITY / MODEL								4 AB 10.2					
											M30-4 H	M40-4 H	M50-4 H	M60-4 H		
											M30-2 H	M40-2 H	M50-2 H	M60-2 H		
ITEM	PART NO.	DESCRIPTION														
1	801992	Gearbox assembly, 6 & 8 K				1	1						1	1		
1	226148	Gearbox assembly, 10 & 12 K						1	1						1	1
2	802120	Gear box mount (NO FRAME LEVELING)				1	1	1	1							
2	803205	Gear box mount (FRAME LEVELING MODELS)											1	1	1	1
3	425330	Strap and bolt kit (2 straps, 4 bolts)				2	2	2	2				2	2	2	2
4	162809	Grease fitting				1	1	1	1				1	1	1	1
5	109752	Bolt				8	8	8	8				8	8	8	8
6	109751	Clamp half (strap)				4	4	4	4				4	4	4	4
7	424647	Crossblock, universal joint (Includes Item 4)				1	1	1	1				1	1	1	1
8	58557	Bolt				8	8	8	8				8	8	8	8
9	42256	Washer				8	8	8	8				8	8	8	8
10	61680	Washer				8	8	8	8				8	8	8	8
11	63547	Bolt				16	16	16	16				16	16	16	16
12	61676	Washer				32	32	32	32				32	32	32	32
13	42231	Washer				32	32	32	32				32	32	32	32
14	58548	Nut				8	8	8	8				8	8	8	8
15	227128	Shock mount				4	4	4	4				4	4	4	4
16	802292	Mount, gear box				2	2	2	2				2	2	2	2
17	KN630091	Washer				8	8	8	8				8	8	8	8
18	KN630361	Washer				8	8	8	8				8	8	8	8
19	61308	Bolt				4	4	4	4				4	4	4	4
20	58546	Bolt				8	8	8	8				8	8	8	8
21	K302211	Screw				6	6	6	6				6	6	6	6
22	42232	Washer				12	12	12	12				12	12	12	12
23	168351	Bolt				12	12	12	12				12	12	12	12
24	801943	Mount, flywheel				2	2	2	2				2	2	2	2
25	----	deleted														

2	S/N: 750157 & ABOVE HYDROSTATIC (TRANSMISSION) SYSTEM ASSEMBLY, 3RD MOUNTING		QUANTITY / MODEL								4 AB 10.2						
											M30-4 H L	M40-4 H L	M50-4 H L	M60-4 H L			
											M30-2 H L	M40-2 H L	M50-2 H L	M60-2 H L			
ITEM	PART NO.	DESCRIPTION															
26	42818	Bolt				6	6	6	6					6	6	6	6
27	62203	Washer				2	2	2	2					2	2	2	2
28	42322	Washer				2	2	2	2					2	2	2	2
29	33593	Clamp				4	4	4	4					4	4	4	4
30	801829	Hydrostatic coupling (less Item 21)				1	1	1	1					1	1	1	1
31	----	deleted															
32	508802	Plate, pump mounting				1	1	1	1					1	1	1	1
33	803271	Hose assembly, hydrostatic supply				1	1	1	1					1	1	1	1
34	803829	Hose assembly, pump to motor				1	1	1	1					1	1	1	1
35	803765	Hose assembly, pump to motor				1	1	1	1					1	1	1	1
36	----	deleted															
37	803611	O-ring				2	2	2	2					2	2	2	2
38	803566	Split flange -12				4	4	4	4					4	4	4	4
39	803570	Split flange -16				4	4	4	4					4	4	4	4
40	803585	O-ring				2	2	2	2					2	2	2	2
41	----	deleted															
42	803275	Hose assembly, pump 'x1'- motor'x2'				2	2	2	2					2	2	2	2
43	----	deleted															
44	802898	Hose, pump 't'- motor 't'				1	1	1	1					1	1	1	1
45	803455	Hose, hydraulic motor to radiator				1	1	1	1					1	1	1	1
46	803454	Hose, hydraulic tank to radiator				1	1	1	1					1	1	1	1
47	B3698-17	clamp, 1 1/4				2	2	2	2					2	2	2	2
48	803885	Hose assembly, 't' to tank				1	1	1	1					1	1	1	1

4 AB 10.5

HYDROSTATIC (TRANSMISSION) ANTI-FOAM FIELD INSTALLATION

M30-2 H	M30-4 H
M40-2 H	M40-4 H
M50-2 H	M50-4 H
M60-2 H	M60-4 H
M30-2 H L	M30-4 H L
M40-2 H L	M40-4 H L
M50-2 H L	M50-4 H L
M60-2 H L	M60-4 H L

ITEMS SHOWN USED FOR FIELD INSTALLATION S/N: 181999 & BELOW

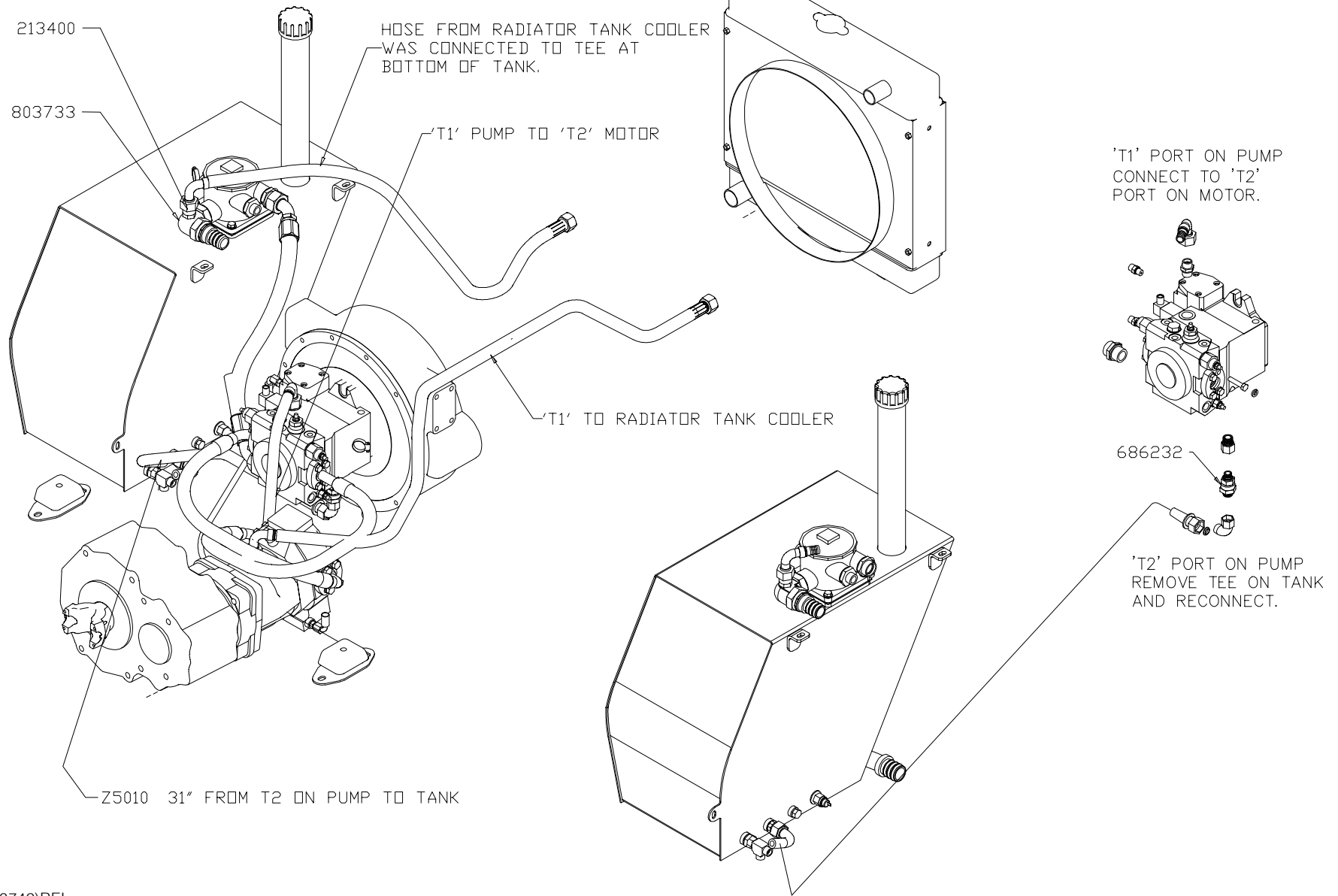

4 AB 10A

HYDROSTATIC COUPLING

M30-2 H	M30-4 H
M40-2 H	M40-4 H
M50-2 H	M50-4 H
M60-2 H	M60-4 H
M30-2 H L	M30-4 H L
M40-2 H L	M40-4 H L
M50-2 H L	M50-4 H L
M60-2 H L	M60-4 H L

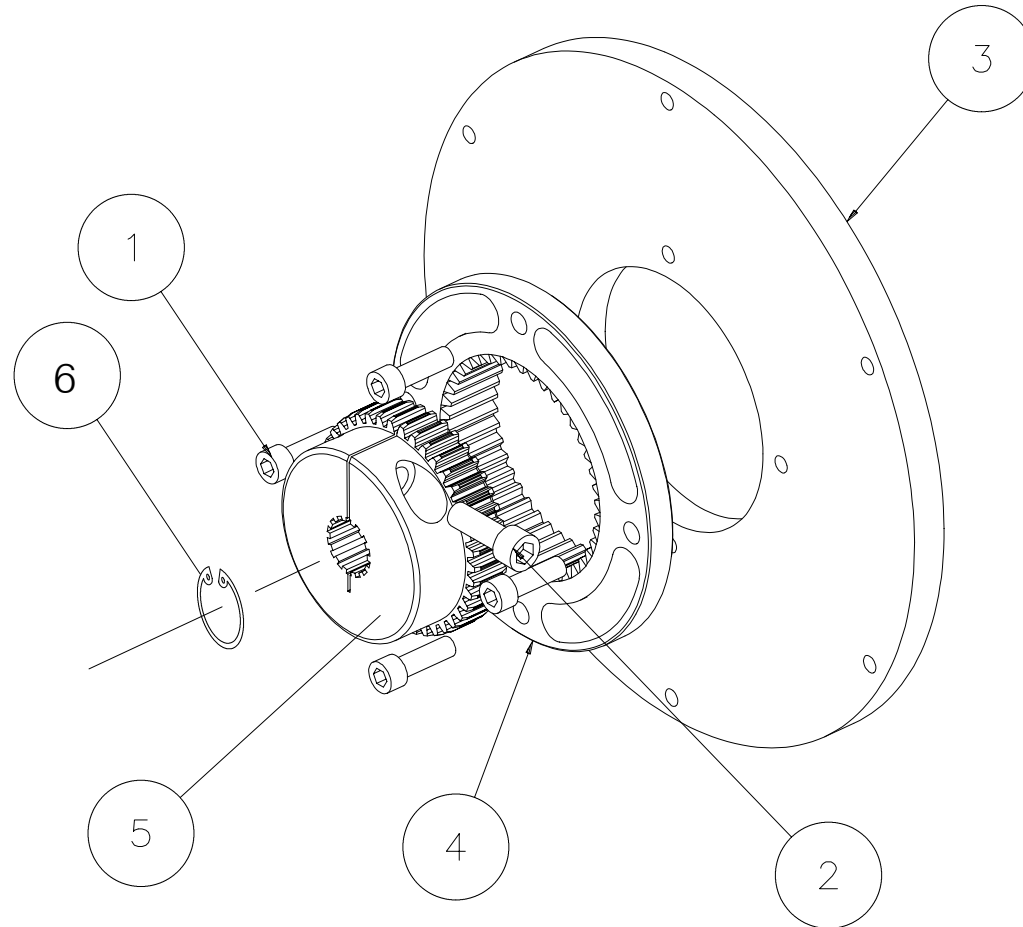

1	HYDROSTATIC COUPLING		QUANTITY / MODEL								4 AB 10A							
							M30-4 H	M40-4 H	M50-4 H	M60-4 H					M30-4 H L	M40-4 H L	M50-4 H L	M60-4 H L
ITEM	PART NO.	DESCRIPTION					M30-2 H	M40-2 H	M50-2 H	M60-2 H					M30-2 H L	M40-2 H L	M50-2 H L	M60-2 H L
1	802461	Screw					4	4	4	4					4	4	4	4
2	802462	Screw					1	1	1	1					1	1	1	1
3	802456	Plate, adapter					1	1	1	1					1	1	1	1
4	802457	Flange, flywheel					1	1	1	1					1	1	1	1
5	802458	Hub, spline					1	1	1	1					1	1	1	1
6	K97615	Snap ring					1	1	1	1					1	1	1	1

4 AB 11

HYDROSTATIC SYSTEM ASSEMBLY

M30-2 H	M30-4 H
M40-2 H	M40-4 H
M50-2 H	M50-4 H
M60-2 H	M60-4 H
M30-2 H L	M30-4 H L
M40-2 H L	M40-4 H L
M50-2 H L	M50-4 H L
M60-2 H L	M60-4 H L

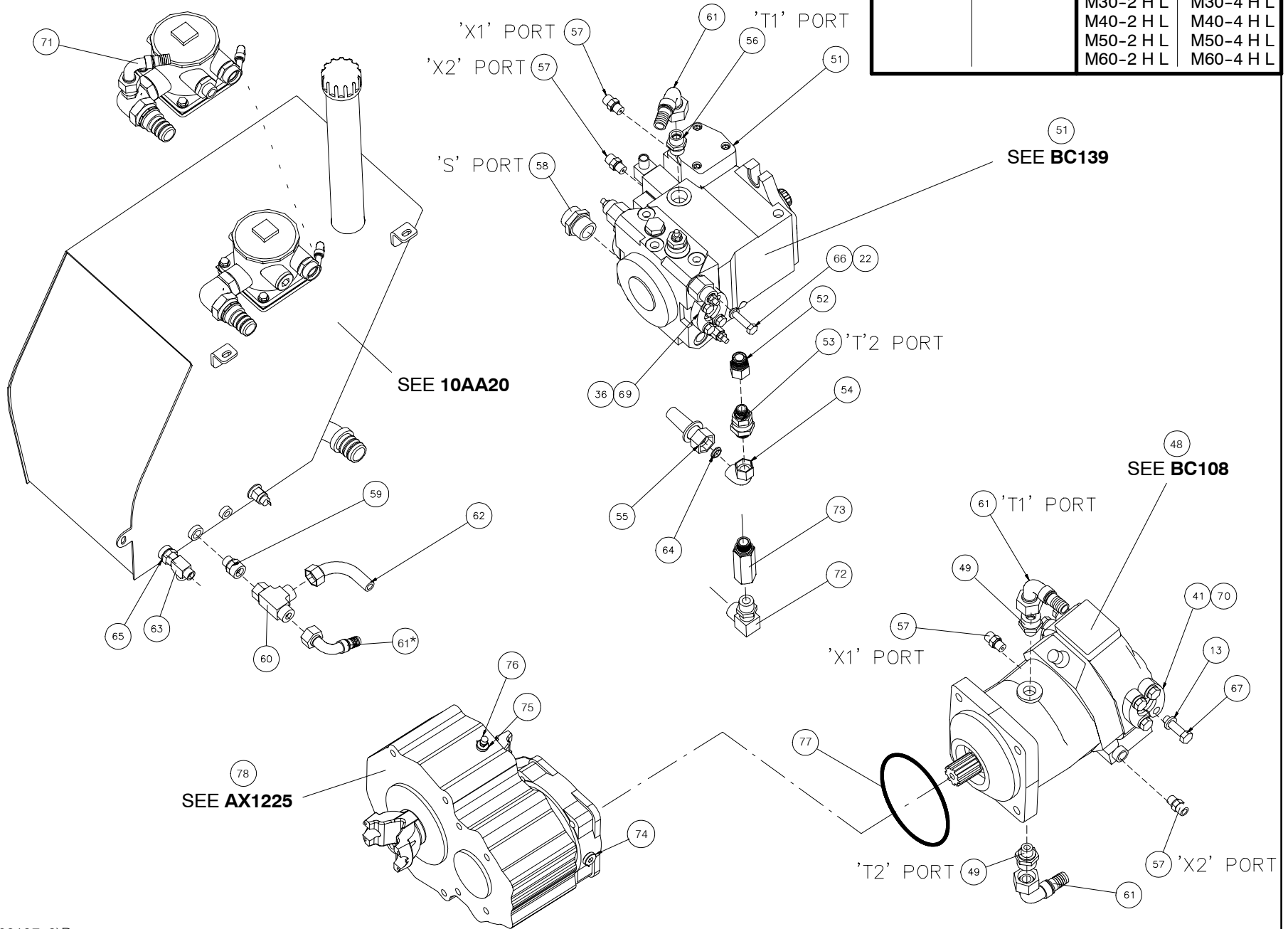

1	HYDROSTATIC SYSTEM ASSEMBLY		QUANTITY / MODEL								4 AB 11			
											M30-4 H L	M40-4 H L	M50-4 H L	M60-4 H L
ITEM	PART NO.	DESCRIPTION	M30-2 H	M40-2 H	M50-2 H	M60-2 H					M30-2 H L	M40-2 H L	M50-2 H L	M60-2 H L
13	42231	Washer, lock	8	8	8	8					8	8	8	8
22	42232	Washer, lock	8	8	8	8					8	8	8	8
36	803566	Split flange -12	4	4	4	4					4	4	4	4
41	803570	Split flange -16	4	4	4	4					4	4	4	4
48	208701	Hydrostatic motor	1	1	1	1					1	1	1	1
49	234267	Adapter	2	2	2	2					2	2	2	2
51	802903	Pump, hydrostatic	1	1	1	1					1	1	1	1
52**	525434	Adapter	1	1	1	1					1	1	1	1
53**	202223	Check valve	1	1	1	1					1	1	1	1
54**	202286	Fitting	1	1	1	1					1	1	1	1
55**	202244	Tube assembly	1	1	1	1					1	1	1	1
56	524789	Adapter	1	1	1	1					1	1	1	1
57	803272	Connector	2	2	2	2					2	2	2	2
58	803270	Connector	1	1	1	1					1	1	1	1
59**	213400	Adapter	1	1	1	1					1	1	1	1
60*	217050	Tee	1	1	1	1					1	1	1	1
61	208561	Fitting	3	3	3	3					3	3	3	3
62**	525436	Tube assembly	1	1	1	1					1	1	1	1
63	R19829-1	Tee, swivel run	1	1	1	1					1	1	1	1
64**	185068	O-ring	1	1	1	1					1	1	1	1
65	803026	Connector	1	1	1	1					1	1	1	1
66	58536	Bolt	8	8	8	8					8	8	8	8
67	29475	Bolt	8	8	8	8					8	8	8	8
69	803585	O-ring -12	2	2	2	2					2	2	2	2
70	803611	O-ring -16	2	2	2	2					2	2	2	2
71	208561	Fitting (3rd Mounting - S/N: 750157 & ABOVE)	1	1	1	1					1	1	1	1

* 1st Mounting - S/N: to 181999

** 1st and 2nd Mounting - S/N: to 750156

2	HYDROSTATIC SYSTEM ASSEMBLY		QUANTITY / MODEL								4 AB 11							
							M30-4 H	M40-4 H	M50-4 H	M60-4 H					M30-4 H L	M40-4 H L	M50-4 H L	M60-4 H L
ITEM	PART NO.	DESCRIPTION					M30-2 H	M40-2 H	M50-2 H	M60-2 H					M30-2 H L	M40-2 H L	M50-2 H L	M60-2 H L
72***	R19452	Elbow					1	1	1	1					1	1	1	1
73***	803886	Check valve, 3 bar					1	1	1	1					1	1	1	1
74	804128	Plug					1	1	1	1					1	1	1	1
75	804130	Plugged, tapped					1	1	1	1					1	1	1	1
76	420431	Breather valve					1	1	1	1					1	1	1	1
77	564073	O-ring					1	1	1	1					1	1	1	1
78A	801992	Gearbox assembly, 6 & 8 K					1	1							1	1		
78B	226148	Gearbox assembly, 10 & 12 K							1	1							1	1
		*** 3rd Mounting - S/N: 750157 & ABOVE																

4 AB 12

HYDROSTATIC INCHING VALVE, TH7 HYDROSTATIC GEARBOX HYDRAULICS

M30-2 H	M30-4 H
M40-2 H	M40-4 H
M50-2 H	M50-4 H
M60-2 H	M60-4 H
M30-2 H L	M30-4 H L
M40-2 H L	M40-4 H L
M50-2 H L	M50-4 H L
M60-2 H L	M60-4 H L

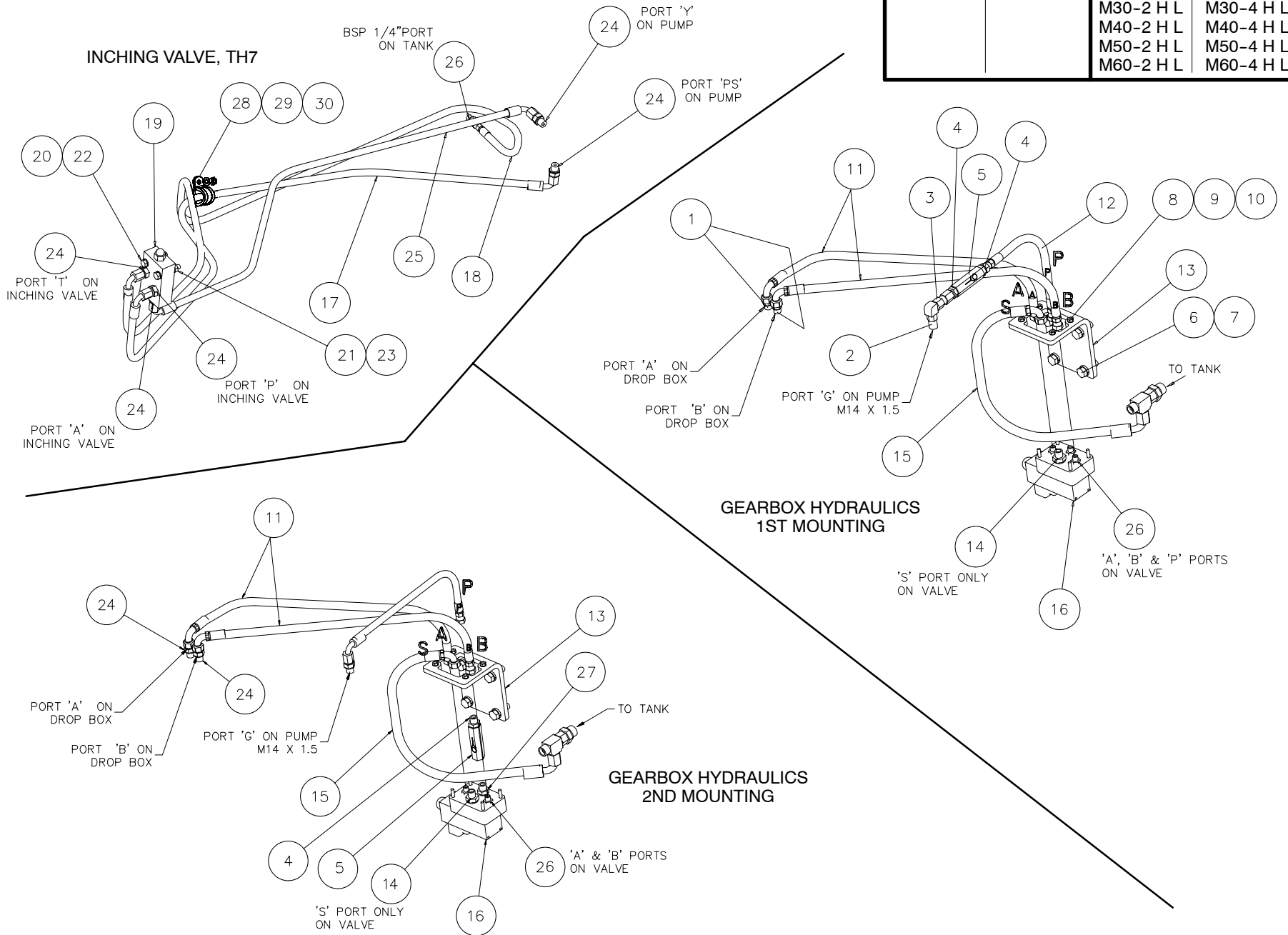

1	HYDROSTATIC GEARBOX HYDRAULICS		QUANTITY / MODEL								4 AB 12					
											M30-4 H L	M40-4 H L	M50-4 H L	M60-4 H L		
											M30-2 H L	M40-2 H L	M50-2 H L	M60-2 H L		
ITEM	PART NO.	DESCRIPTION														
1	803173	Connector				2	2	2	2				2	2	2	2
2	803179	Connector				1	1	1	1				1	1	1	1
3	803178	Union swivel nut				1	1	1	1				1	1	1	1
4	803196	Connector				2	2	2	2				2	2	2	2
5	62179	Check valve				1	1	1	1				1	1	1	1
6	58546	Bolt				4	4	4	4				4	4	4	4
7	42231	Washer				4	4	4	4				4	4	4	4
8	168706	Screw				4	4	4	4				4	4	4	4
9	25714	Nut				4	4	4	4				4	4	4	4
10	174132	Washer				4	4	4	4				4	4	4	4
11	803175	Hose assembly				2	2	2	2				2	2	2	2
12	803176	Hose assembly				1	1	1	1				1	1	1	1
13	802504	Plate, valve support				1	1	1	1				1	1	1	1
14	803174	Connector				1	1	1	1				1	1	1	1
15	803180	Hose assembly				1	1	1	1				1	1	1	1
16	60998	Electrovalve				1	1	1	1				1	1	1	1
17	803181	Hose assembly				1	1	1	1				1	1	1	1
18	803185	Hose assembly				1	1	1	1				1	1	1	1
19	75498	Valve				1	1	1	1				1	1	1	1
20	61674	Washer				4	4	4	4				4	4	4	4
21	58528	Nut				2	2	2	2				2	2	2	2
22	58531	Bolt				2	2	2	2				2	2	2	2
23	42325	Washer				2	2	2	2				2	2	2	2
24	803182	Connector				5	5	5	5				5	5	5	5
25	803183	Hose assembly				1	1	1	1				1	1	1	1
26	803184	Connector				4	4	4	4				4	4	4	4
27	803684	Connector				1	1	1	1				1	1	1	1
28	86506	Clamp				1	1	1	1				1	1	1	1
29	K44722	Washer				1	1	1	1				1	1	1	1
30	K55691	Nut				1	1	1	1				1	1	1	1

4 AC 10

FUEL TANK ASSEMBLY

NOTES:

1. APPLY LOCTITE 243 (BLUE) TO MALE FASTENER THREADS PRIOR TO INSTALLING.

M30-2	M30-4	M30-2 H	M30-4 H
M40-2	M40-4	M40-2 H	M40-4 H
M50-2	M50-4	M50-2 H	M50-4 H
M60-2	M60-4	M60-2 H	M60-4 H
M30-2 L	M30-4 L	M30-2 H L	M30-4 H L
M40-2 L	M40-4 L	M40-2 H L	M40-4 H L
M50-2 L	M50-4 L	M50-2 H L	M50-4 H L
M60-2 L	M60-4 L	M60-2 H L	M60-4 H L

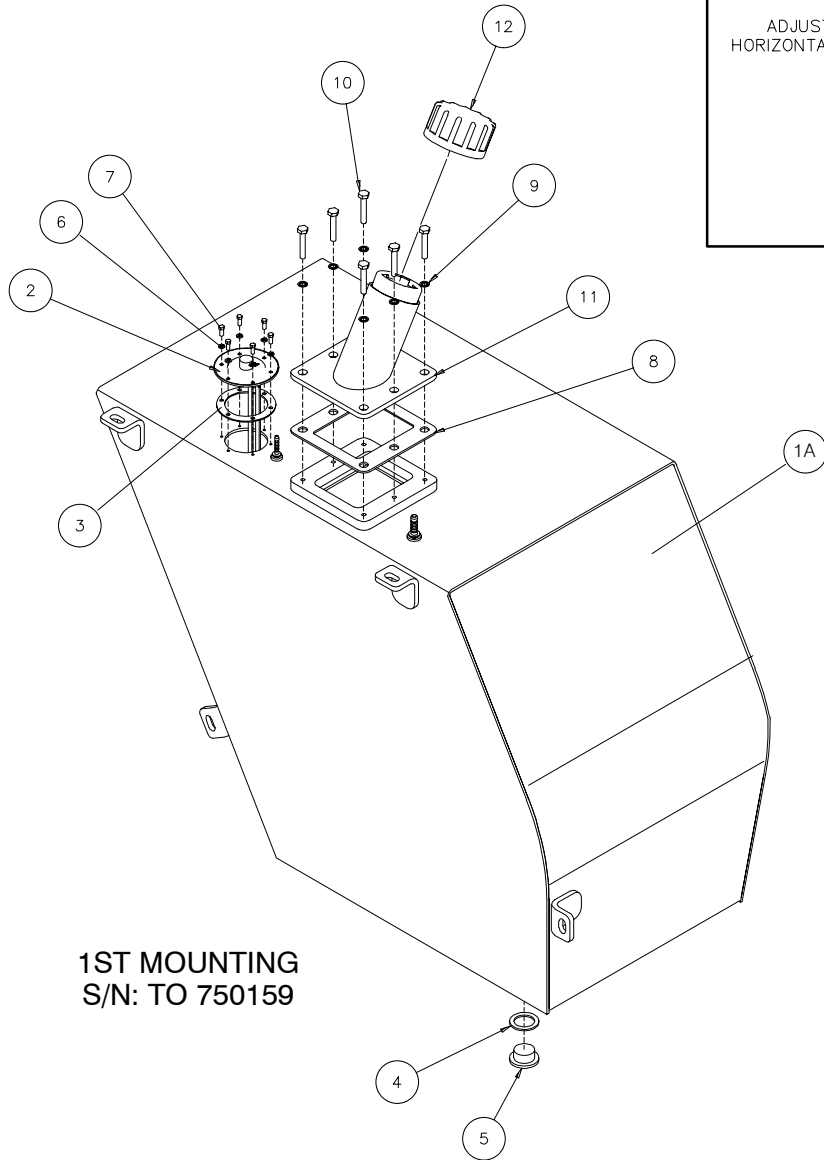

**1ST MOUNTING
S/N: TO 750159**

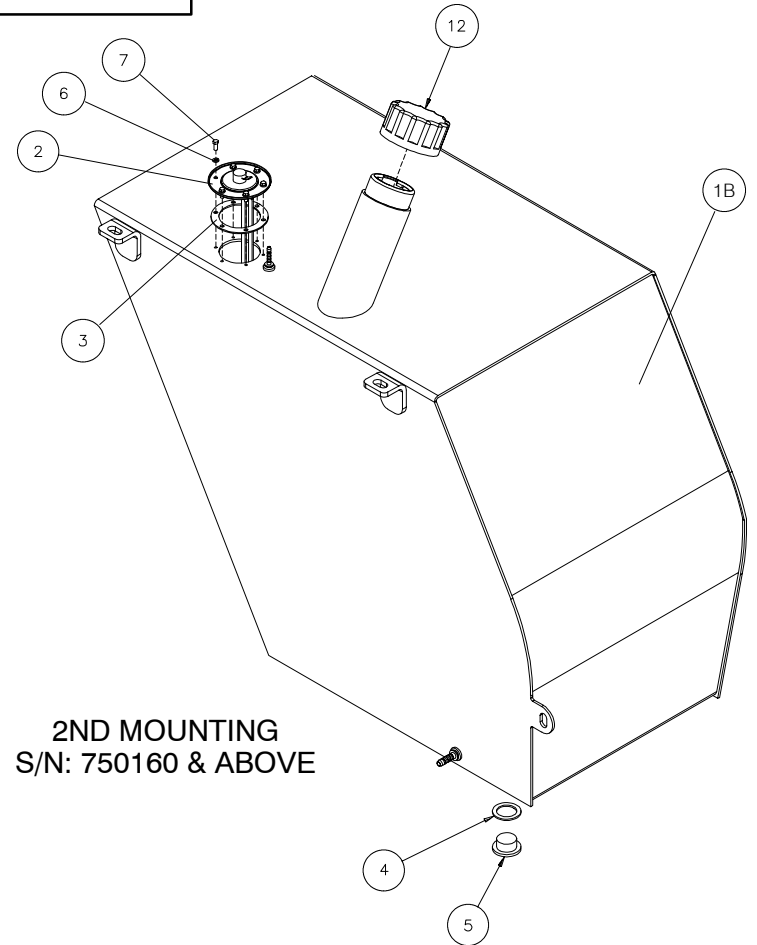
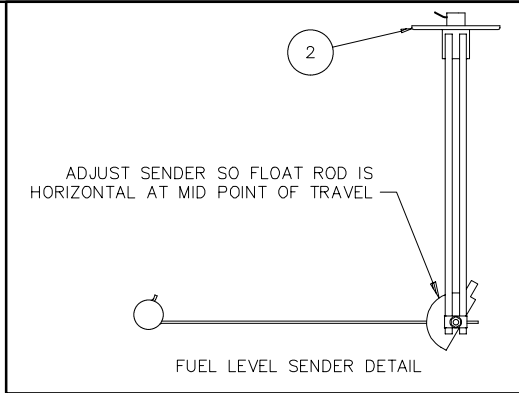

**2ND MOUNTING
S/N: 750160 & ABOVE**

1	FUEL TANK ASSEMBLY		QUANTITY / MODEL											4 AC 10				
			M30-4	M40-4	M50-4	M60-4	M30-4 H	M40-4 H	M50-4 H	M60-4 H	M30-4 L	M40-4 L	M50-4 L	M60-4 L	M30-4 H L	M40-4 H L	M50-4 H L	M60-4 H L
ITEM	PART NO.	DESCRIPTION	M30-2	M40-2	M50-2	M60-2	M30-2 H	M40-2 H	M50-2 H	M60-2 H	M30-2 L	M40-2 L	M50-2 L	M60-2 L	M30-2 H L	M40-2 H L	M50-2 H L	M60-2 H L
1A	802161	Tank, diesel	1	1	1	1	1	1	1	1	1	1	1	1	1	1	1	1
1B	803536	Tank, diesel	1	1	1	1	1	1	1	1	1	1	1	1	1	1	1	1
2	187283	Sender, fuel level	1	1	1	1	1	1	1	1	1	1	1	1	1	1	1	1
3	187485	Gasket	1	1	1	1	1	1	1	1	1	1	1	1	1	1	1	1
4	189536	Seal, drain plug	1	1	1	1	1	1	1	1	1	1	1	1	1	1	1	1
5	189535	Drain plug	1	1	1	1	1	1	1	1	1	1	1	1	1	1	1	1
6	187294	Washer	6	6	6	6	6	6	6	6	6	6	6	6	6	6	6	6
7	802288	Bolt	6	6	6	6	6	6	6	6	6	6	6	6	6	6	6	6
8	802909	Gasket	1	1	1	1	1	1	1	1	1	1	1	1	1	1	1	1
9	K34805SS	Washer	6	6	6	6	6	6	6	6	6	6	6	6	6	6	6	6
10	K20344	Bolt	6	6	6	6	6	6	6	6	6	6	6	6	6	6	6	6
11A*	803453	Filler, short (5.25 in. long tube)	1	1	1	1	1	1	1	1	1	1	1	1	1	1	1	1
11B*	802925	Filler, tall (10 in. long tube) EARLY MODELS ONLY	1	1	1	1	1	1	1	1	1	1	1	1	1	1	1	1
12A	425501	Filler cap, vented	1	1	1	1	1	1	1	1	1	1	1	1	1	1	1	1
12B	803411	Fuel cap, anti-vandal (welding required) includes: cap (195538), padlock (803575), tab, weld (803533)	1	1	1	1	1	1	1	1	1	1	1	1	1	1	1	1

* These Items are not interchangeable.

4 AC 11

FUEL TANK AND LIFT PUMP INSTALLATION

M30-2	M30-4	M30-2 H	M30-4 H
M40-2	M40-4	M40-2 H	M40-4 H
M50-2	M50-4	M50-2 H	M50-4 H
M60-2	M60-4	M60-2 H	M60-4 H
M30-2 L	M30-4 L	M30-2 H L	M30-4 H L
M40-2 L	M40-4 L	M40-2 H L	M40-4 H L
M50-2 L	M50-4 L	M50-2 H L	M50-4 H L
M60-2 L	M60-4 L	M60-2 H L	M60-4 H L

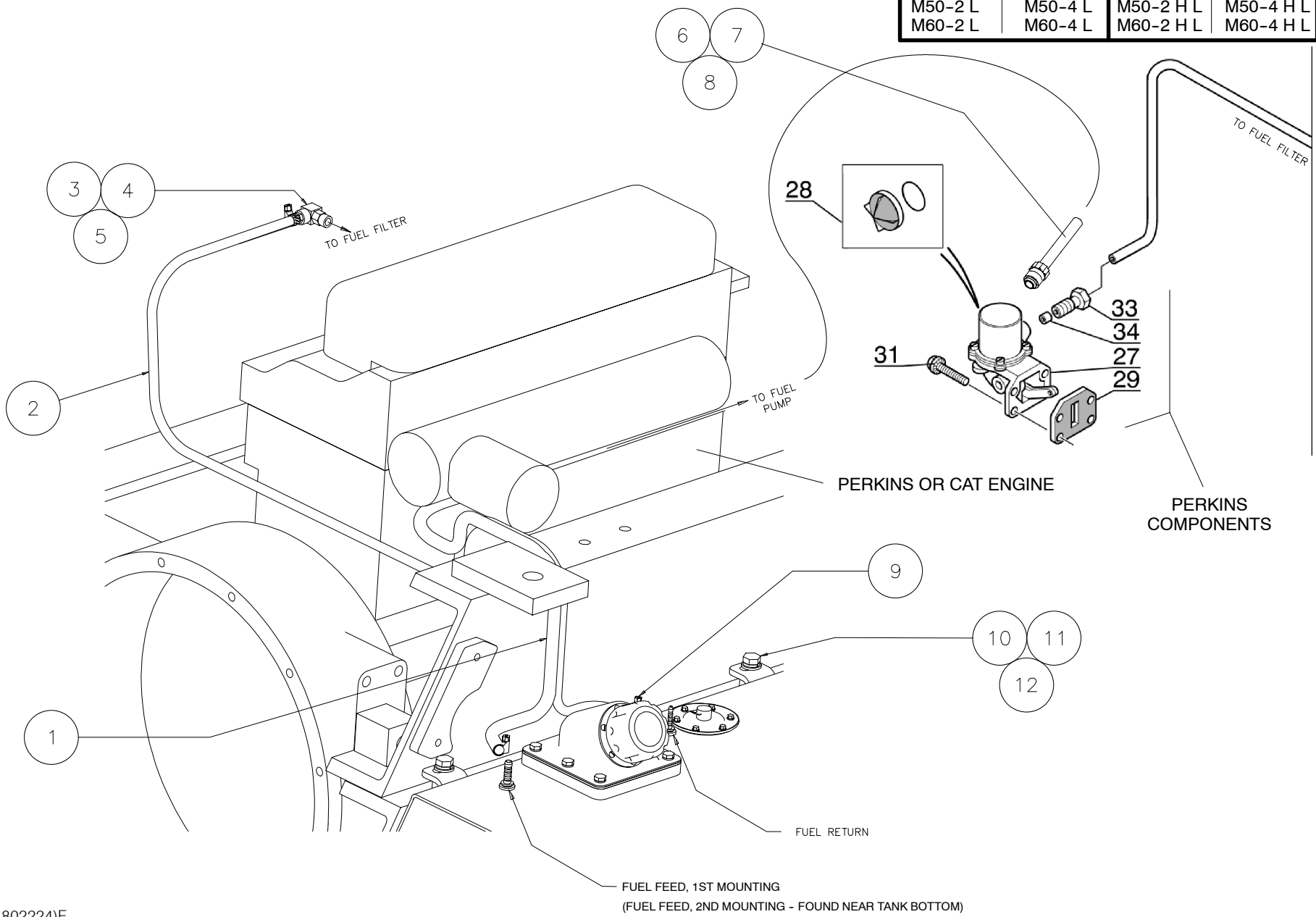

1	FUEL TANK AND LIFT PUMP INSTALLATION		QUANTITY / MODEL											4 AC 11				
			M30-4	M40-4	M50-4	M60-4	M30-4 H	M40-4 H	M50-4 H	M60-4 H	M30-4 L	M40-4 L	M50-4 L	M60-4 L	M30-4 H L	M40-4 H L	M50-4 H L	M60-4 H L
ITEM	PART NO.	DESCRIPTION	M30-2	M40-2	M50-2	M60-2	M30-2 H	M40-2 H	M50-2 H	M60-2 H	M30-2 L	M40-2 L	M50-2 L	M60-2 L	M30-2 H L	M40-2 H L	M50-2 H L	M60-2 H L
1A*	Z2805-34	Hose, fuel feed, 34 in.	1	1	1	1	1	1	1	1	1	1	1	1	1	1	1	1
1B**	Z2805-62	Hose, fuel feed, 62 in.	1	1	1	1	1	1	1	1	1	1	1	1	1	1	1	1
2	802758	Hose, fuel return	1	1	1	1	1	1	1	1	1	1	1	1	1	1	1	1
3	B3500	Adapter, fuel line	1	1	1	1	1	1	1	1	1	1	1	1	1	1	1	1
4	B103A1	Elbow	1	1	1	1	1	1	1	1	1	1	1	1	1	1	1	1
5	K87550	Connector	1	1	1	1	1	1	1	1	1	1	1	1	1	1	1	1
6	422647	Tube assembly, fuel inlet	1	1	1	1	1	1	1	1	1	1	1	1	1	1	1	1
7	K40-5	Nut, flare	1	1	1	1	1	1	1	1	1	1	1	1	1	1	1	1
8	K376016	Sleeve	1	1	1	1	1	1	1	1	1	1	1	1	1	1	1	1
9	479218	Hose clamp	4	4	4	4	4	4	4	4	4	4	4	4	4	4	4	4
10A*	42347	Bolt	4	4	4	4	4	4	4	4	4	4	4	4	4	4	4	4
10B**	63727	Bolt	3	3	3	3	3	3	3	3	3	3	3	3	3	3	3	3
11A*	42325	Washer	4	4	4	4	4	4	4	4	4	4	4	4	4	4	4	4
11B**	42232	Washer	3	3	3	3	3	3	3	3	3	3	3	3	3	3	3	3
12A*	61674	Washer	4	4	4	4	4	4	4	4	4	4	4	4	4	4	4	4
12B**	29437	Washer	3	3	3	3	3	3	3	3	3	3	3	3	3	3	3	3
27	601824	Fuel (lift) pump (Perkins component)	1	1	1	1	1	1	1	1	1	1	1	1	1	1	1	1
28	602106	Repair kit (Perkins component)	1	1	1	1	1	1	1	1	1	1	1	1	1	1	1	1
29	475374	Gasket (Perkins component)	1	1	1	1	1	1	1	1	1	1	1	1	1	1	1	1
31	473955	Screw (Perkins component)	4	4	4	4	4	4	4	4	4	4	4	4	4	4	4	4
33	138141	Connection (Perkins component)	2	2	2	2	2	2	2	2	2	2	2	2	2	2	2	2
34	563329	Bushing (Perkins component)	1	1	1	1	1	1	1	1	1	1	1	1	1	1	1	1

* 1ST MOUNTING, S/N: TO 750159
** 2ND MOUNTING, S/N: 750160 & ABOVE

5 AA 10

MAST MOUNTING HARDWARE

M30-2	M30-4	M30-2 H	M30-4 H
M40-2	M40-4	M40-2 H	M40-4 H
M50-2	M50-4	M50-2 H	M50-4 H
M60-2	M60-4	M60-2 H	M60-4 H
M30-2 L	M30-4 L	M30-2 H L	M30-4 H L
M40-2 L	M40-4 L	M40-2 H L	M40-4 H L
M50-2 L	M50-4 L	M50-2 H L	M50-4 H L
M60-2 L	M60-4 L	M60-2 H L	M60-4 H L

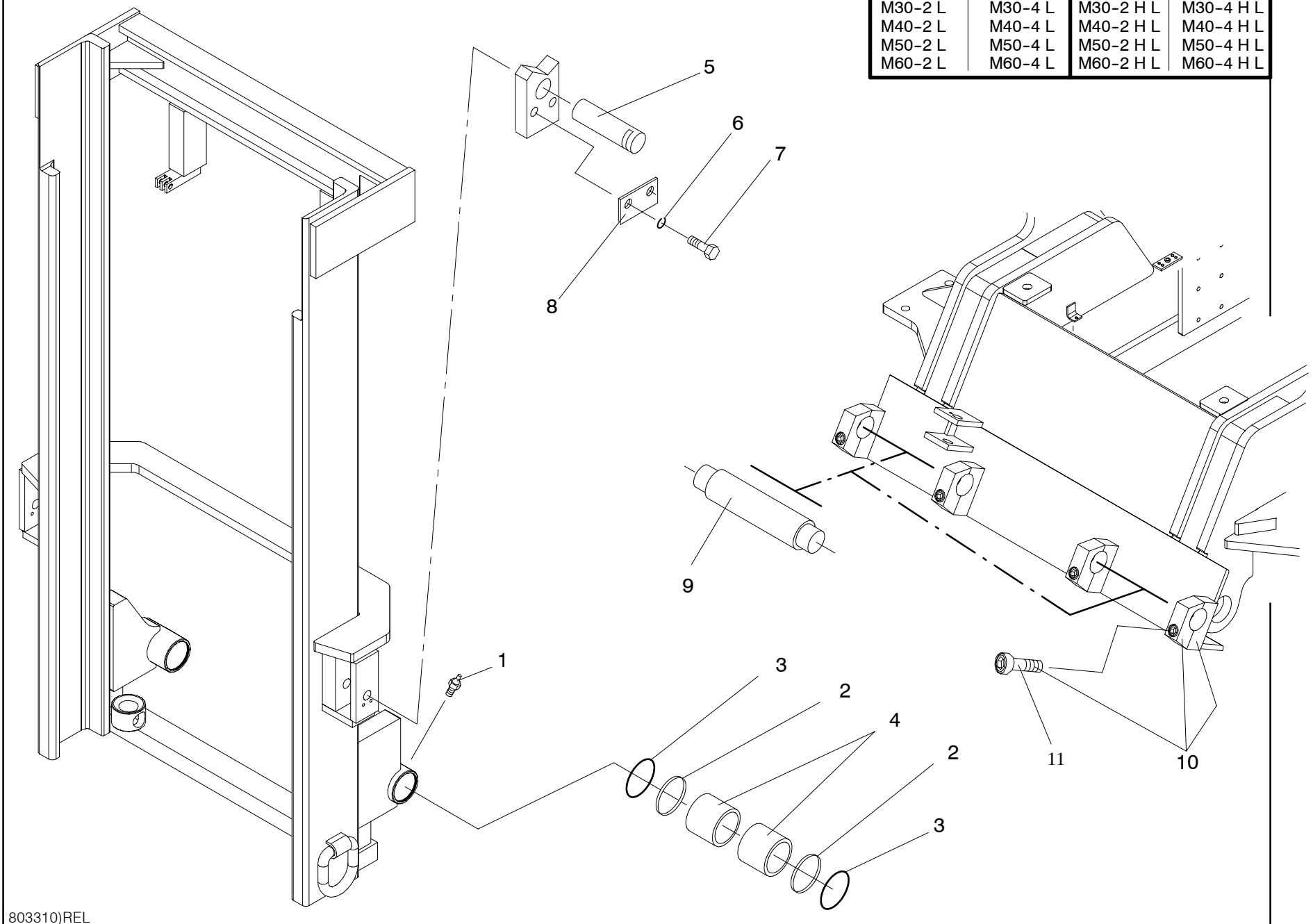

1	MAST MOUNTING HARDWARE												5 AA 10						
	ITEM	PART NO.	DESCRIPTION	M30-2	M40-2	M50-2	M60-2	M30-2 H	M40-2 H	M50-2 H	M60-2 H	M30-2 L	M40-2 L	M50-2 L	M60-2 L	M30-4 H L	M40-4 H L	M50-4 H L	M60-4 H L
1	K87901	Grease fitting		2	2	2	2	2	2	2	2	2	2	2	2	2	2	2	2
2	R106	Ring, retaining		4	4	4	4	4	4	4	4	4	4	4	4	4	4	4	4
3	R4584	Wiper		4	4	4	4	4	4	4	4	4	4	4	4	4	4	4	4
4	R7638	Bearing, mast mounting		4	4	4	4	4	4	4	4	4	4	4	4	4	4	4	4
5	R25454	Pin, tilt mount		2	2	2	2	2	2	2	2	2	2	2	2	2	2	2	2
6	K34807	Washer, lock		4	4	4	4	4	4	4	4	4	4	4	4	4	4	4	4
7	K20388	Bolt		4	4	4	4	4	4	4	4	4	4	4	4	4	4	4	4
8	R25456	Plate, pin retaining		2	2	2	2	2	2	2	2	2	2	2	2	2	2	2	2
9	B5407	Bar, mast support		2	2	2	2	2	2	2	2	2	2	2	2	2	2	2	2
10	B5795*	Cap and base assembly		4	4	4	4	4	4	4	4	4	4	4	4	4	4	4	4
11	B6119	Bolt		4	4	4	4	4	4	4	4	4	4	4	4	4	4	4	4
		* Welding required, must show proof of certification																	

6 AA 10

FRAME AND COUNTERWEIGHTS

M30-2	M30-4	M30-2 H	M30-4 H
M40-2	M40-4	M40-2 H	M40-4 H
M50-2	M50-4	M50-2 H	M50-4 H
M60-2	M60-4	M60-2 H	M60-4 H
M30-2 L	M30-4 L	M30-2 H L	M30-4 H L
M40-2 L	M40-4 L	M40-2 H L	M40-4 H L
M50-2 L	M50-4 L	M50-2 H L	M50-4 H L
M60-2 L	M60-4 L	M60-2 H L	M60-4 H L

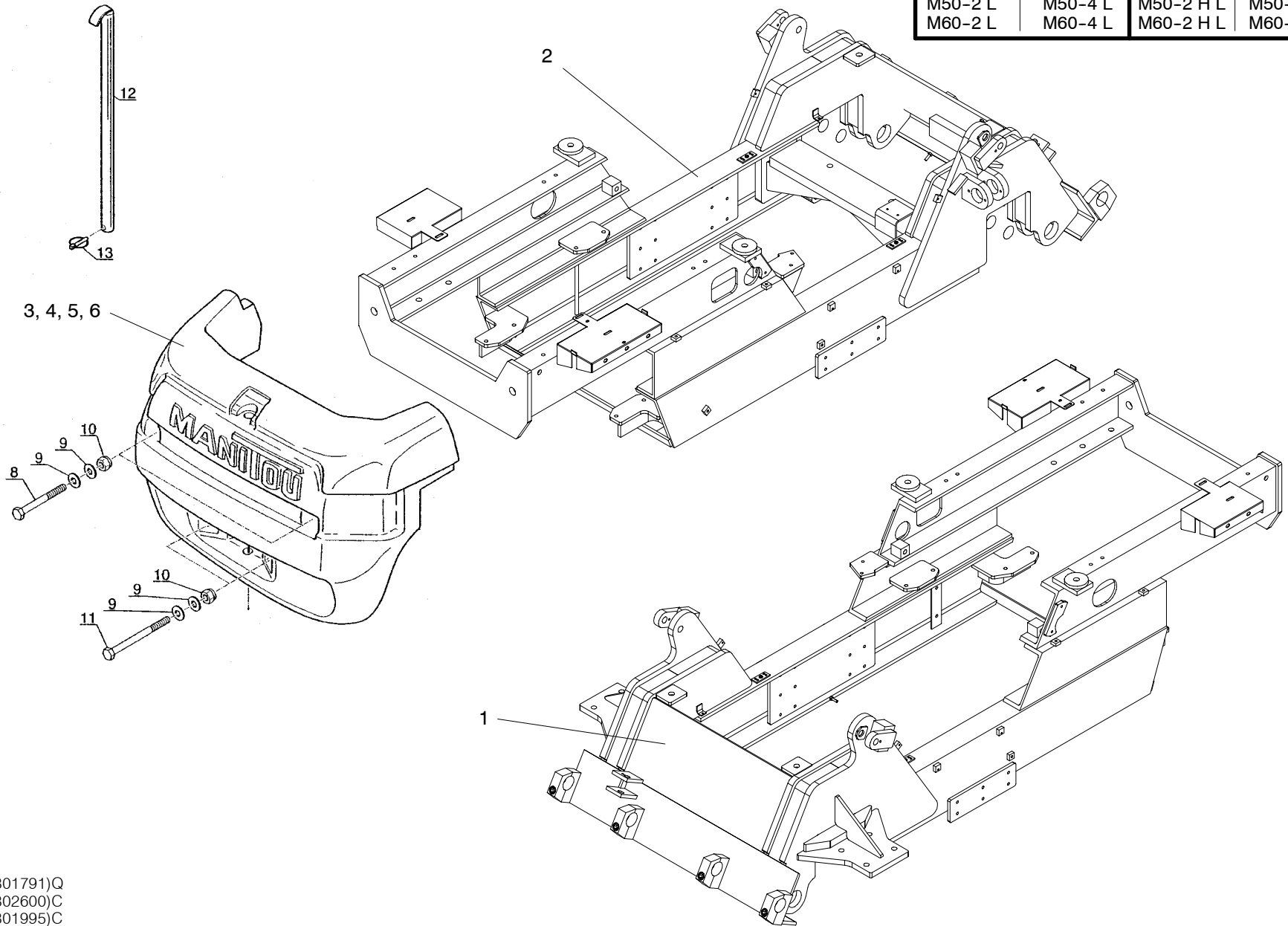

801791)Q
 802600)C
 801995)C
 MBF 6AA197

1	FRAME AND COUNTERWEIGHTS												6 AA 10						
	ITEM	PART NO.	DESCRIPTION	M30-2	M40-2	M50-2	M60-2	M30-2 H	M40-2 H	M50-2 H	M60-2 H	M30-2 L	M40-2 L	M50-2 L	M60-2 L	M30-2 H L	M40-2 H L	M50-2 H L	M60-2 H L
1A*	801791-N	Frame, revision 'N' (ALL, EXCEPT FRAME LEVELING)	1	1	1	1	1	1	1	1									
1B**	801791	Frame (ALL, EXCEPT FRAME LEVELING)	1	1	1	1	1	1	1	1									
2A*	802600-B	Frame, revision 'B' (FRAME LEVELING ONLY)									1	1	1	1	1	1	1	1	1
2B**	802600	Frame (FRAME LEVELING ONLY)									1	1	1	1	1	1	1	1	1
3	218177	Counterweight	1				1				1				1				
4	218178	Counterweight		1				1				1				1			
5	218179	Counterweight			1				1				1				1		
6	218180	Counterweight				1				1				1					1
8	75992	Screw	2	2	2	2	2	2	2	2	2	2	2	2	2	2	2	2	2
9	63936	Washer	8	8	8	8	8	8	8	8	8	8	8	8	8	8	8	8	8
10	184642	Nut	4	4	4	4	4	4	4	4	4	4	4	4	4	4	4	4	4
11	168379	Screw	2	2	2	2	2	2	2	2	2	2	2	2	2	2	2	2	2
12A	219518	Towing spindle	1				1				1				1				1
12B	218265	Towing spindle		1	1	1		1	1	1		1	1	1		1	1	1	1
13	32963	Pin	1	1	1	1	1	1	1	1	1	1	1	1	1	1	1	1	1

* S/N: 750171 & below (including 750173)

** S/N: 750172 & above (less 750173)

SIDE STEP INSTALLATION

M30-2	M30-4	M30-2 H	M30-4 H
M40-2	M40-4	M40-2 H	M40-4 H
M50-2	M50-4	M50-2 H	M50-4 H
M60-2	M60-4	M60-2 H	M60-4 H
M30-2 L	M30-4 L	M30-2 H L	M30-4 H L
M40-2 L	M40-4 L	M40-2 H L	M40-4 H L
M50-2 L	M50-4 L	M50-2 H L	M50-4 H L
M60-2 L	M60-4 L	M60-2 H L	M60-4 H L

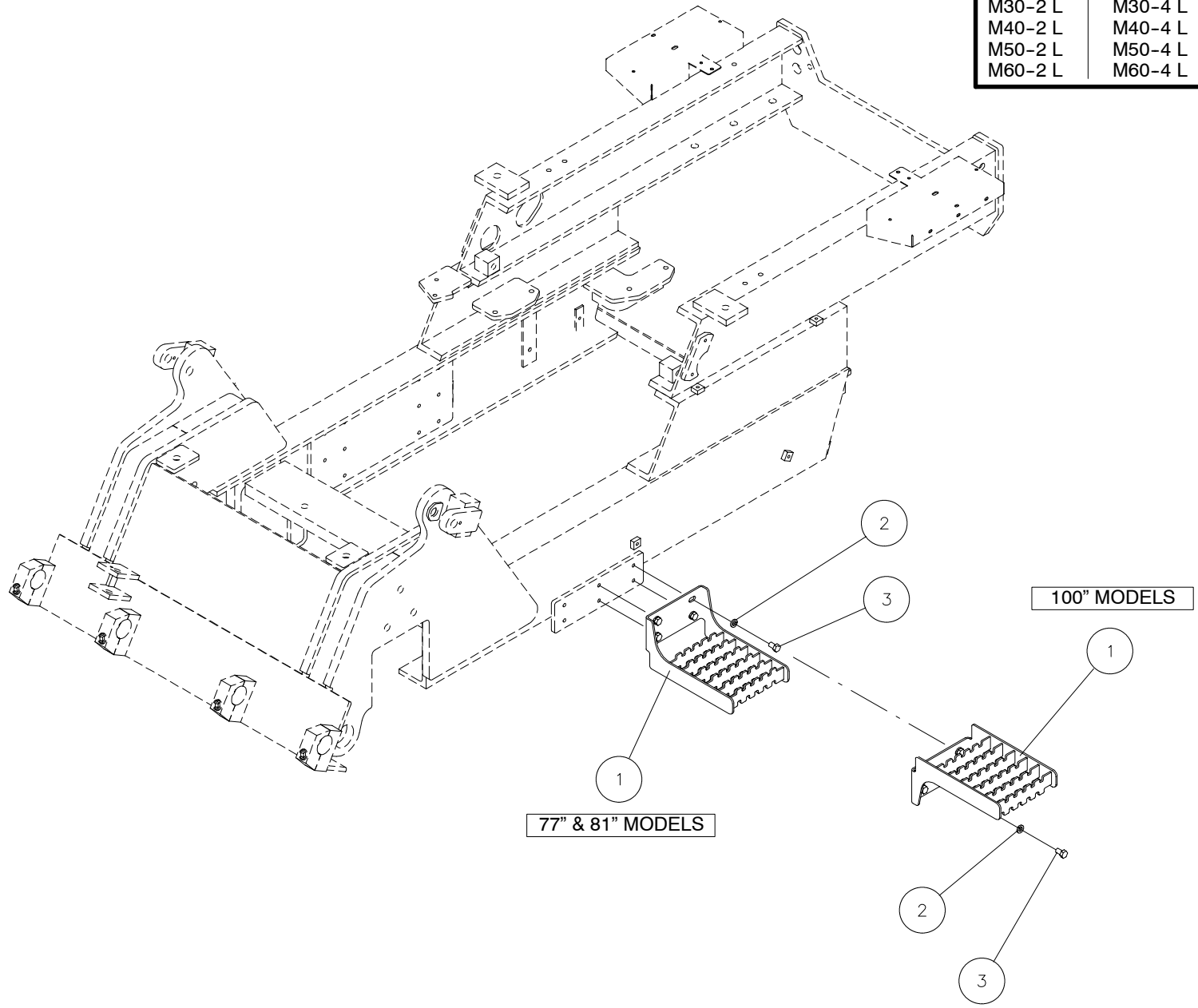

ITEM	PART NO.	DESCRIPTION	QUANTITY / MODEL												6 AA 11			
			M30-2	M40-2	M50-2	M60-2	M30-2 H	M40-2 H	M50-2 H	M60-2 H	M30-2 L	M40-2 L	M50-2 L	M60-2 L	M30-2 H L	M40-2 H L	M50-2 H L	M60-2 H L
1	803768	Step assembly, all models	2	2	2	2	2	2	2	2	2	2	2	2	2	2	2	2
2	42231	Washer	8	8	8	8	8	8	8	8	8	8	8	8	8	8	8	8
3	63546	Bolt	8	8	8	8	8	8	8	8	8	8	8	8	8	8	8	8

6 AA 20

FRONT DRIVE AXLE AND DRIVESHAFT INSTALLATION (EXCEPT FRAME LEVELING)

M30-2	M30-4	M30-2 H	M30-4 H
M40-2	M40-4	M40-2 H	M40-4 H
M50-2	M50-4	M50-2 H	M50-4 H
M60-2	M60-4	M60-2 H	M60-4 H

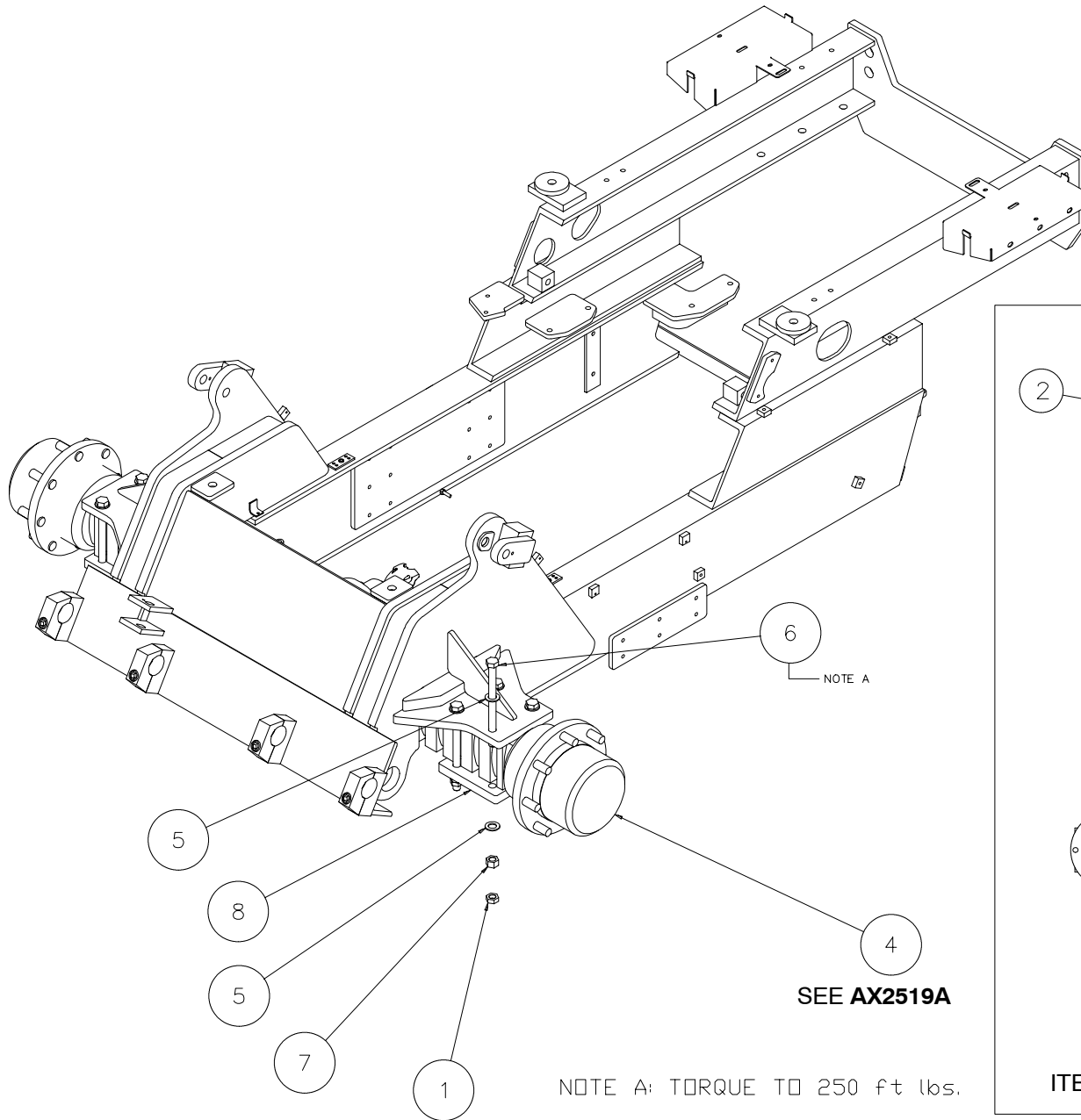

NOTE A: TORQUE TO 250 ft lbs.

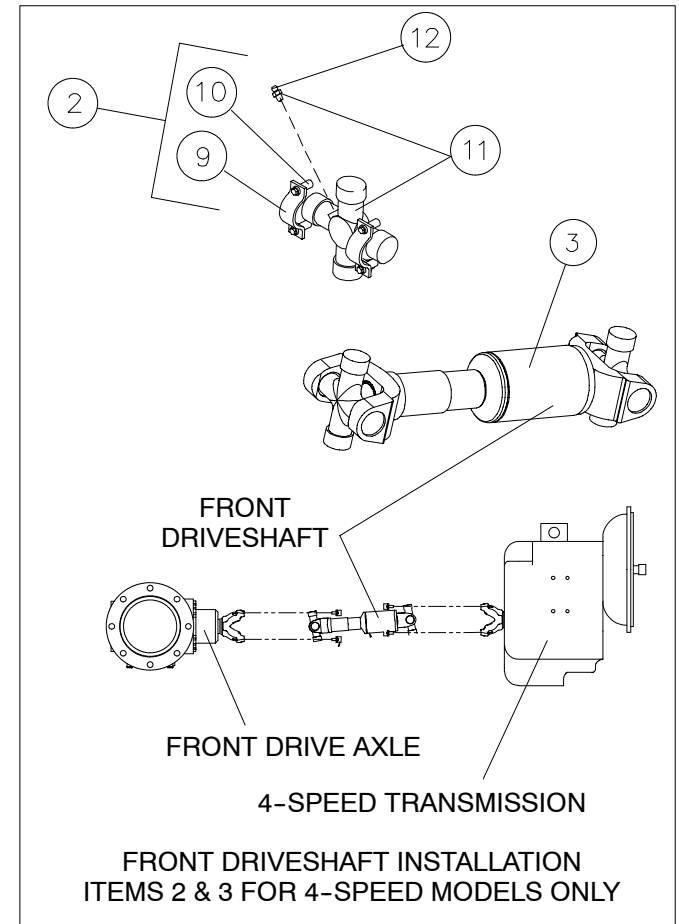

			QUANTITY / MODEL								6 AA 20			
			M30-4	M40-4	M50-4	M60-4	M30-4 H	M40-4 H	M50-4 H	M60-4 H				
1 FRONT DRIVE AXLE INSTALLATION (EXCEPT FRAME LEVELING)			M30-2	M40-2	M50-2	M60-2	M30-2 H	M40-2 H	M50-2 H	M60-2 H				
ITEM	PART NO.	DESCRIPTION	M30-2	M40-2	M50-2	M60-2	M30-2 H	M40-2 H	M50-2 H	M60-2 H				
1	K34691	Nut, jam	8	8	8	8	8	8	8	8				
2	425330	Strap and bolt kit (4-SPEED MODELS ONLY)	2	2	2	2	2	2	2	2				
3	802047	Driveshaft, front (4-SPEED MODELS ONLY)	1	1	1	1	1	1	1	1				
4	801989	Axle, front drive	1	1	1	1	1	1	1	1				
5	426650	Washer, flat	16	16	16	16	16	16	16	16				
6	426648	Bolt	8	8	8	8	8	8	8	8				
7	426649	Nut	8	8	8	8	8	8	8	8				
8	803560	Plate, axle mount	2	2	2	2	2	2	2	2				
9	109751	Clamp half	4	4	4	4	4	4	4	4				
10	109752	Bolt	8	8	8	8	8	8	8	8				
11	424647	U-joint	2	2	2	2	2	2	2	2				
12	162809	Zerk, grease fitting	2	2	2	2	2	2	2	2				

6 AA 30

FRONT DRIVE AXLE AND DRIVESHAFT INSTALLATION (FRAME LEVELING)

M30-2 L	M30-4 L	M30-2 H L	M30-4 H L
M40-2 L	M40-4 L	M40-2 H L	M40-4 H L
M50-2 L	M50-4 L	M50-2 H L	M50-4 H L
M60-2 L	M60-4 L	M60-2 H L	M60-4 H L

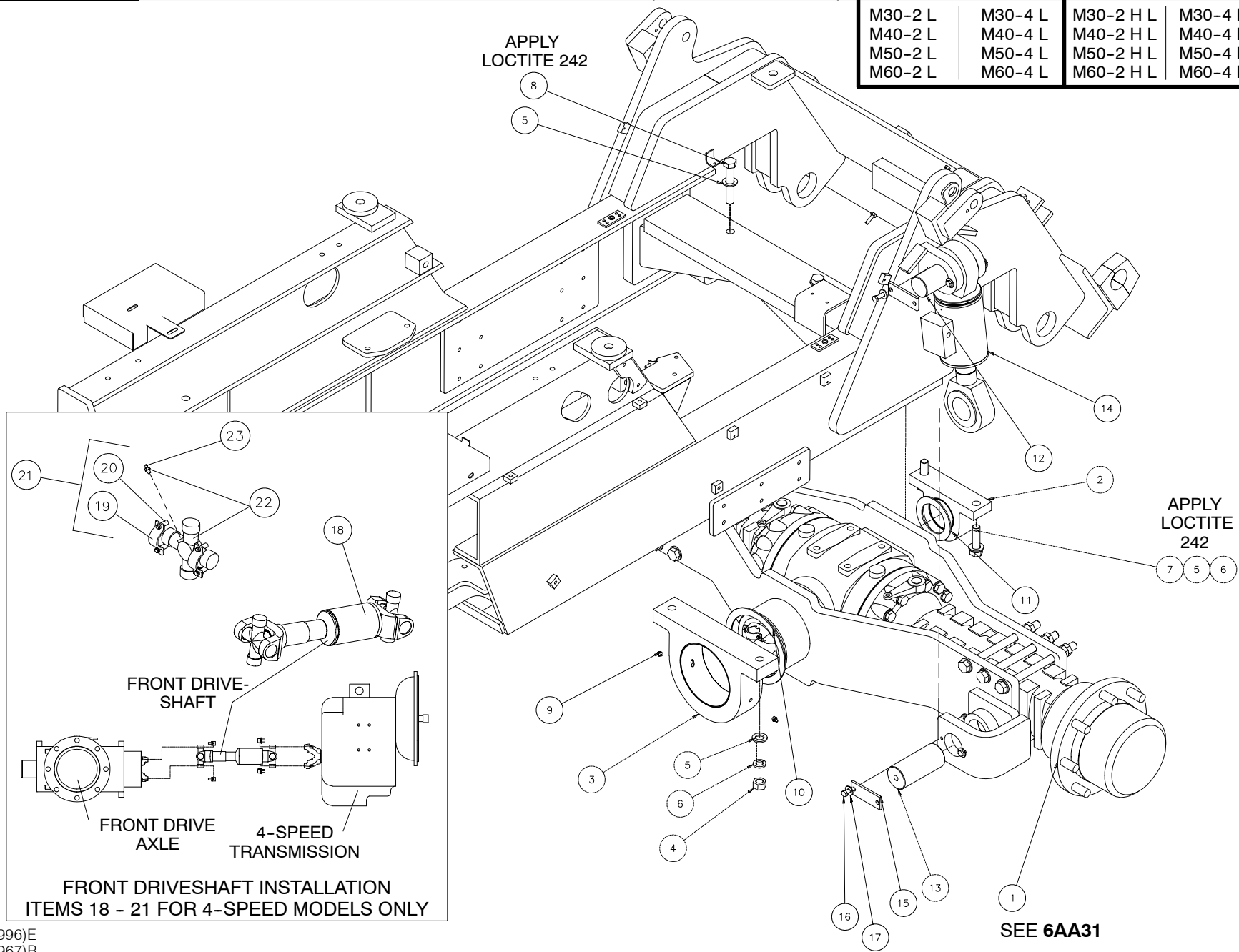

1	FRONT DRIVE AXLE INSTALLATION (FRAME LEVELING)		QUANTITY / MODEL								6 AA 30						
											M30-4 L	M40-4 L	M50-4 L	M60-4 L	M30-4 H L	M40-4 H L	M50-4 H L
ITEM	PART NO.	DESCRIPTION								M30-2 L	M40-2 L	M50-2 L	M60-2 L	M30-2 H L	M40-2 H L	M50-2 H L	M60-2 H L
1	801972	Axle sub-assembly, frame leveling								1	1	1	1	1	1	1	1
2	801964	Axle bracket assembly, front								1	1	1	1	1	1	1	1
3	801965	Axle bracket assembly, rear								1	1	1	1	1	1	1	1
4	426649	Nut								4	4	4	4	4	4	4	4
5	426650	Washer								10	10	10	10	10	10	10	10
6	K34813	Washer								4	4	4	4	4	4	4	4
7	K45805	Bolt								2	2	2	2	2	2	2	2
8	K45860	Bolt								2	2	2	2	2	2	2	2
9	T51534	Grease fitting								3	3	3	3	3	3	3	3
10	803544	Spacer								1	1	1	1	1	1	1	1
11	803545	Spacer								1	1	1	1	1	1	1	1
12	803229	Pin								1	1	1	1	1	1	1	1
13	801924	Pin								1	1	1	1	1	1	1	1
14	803617	Cylinder, frame leveling								1	1	1	1	1	1	1	1
15	803614	Plate								3	3	3	3	3	3	3	3
16	K20428	Bolt								6	6	6	6	6	6	6	6
17	K44728	Washer								6	6	6	6	6	6	6	6
18	802047	Driveshaft, front								1	1	1	1	1	1	1	1
19	109751	Clamp half								4	4	4	4	4	4	4	4
20	109752	Bolt								8	8	8	8	8	8	8	8
21	425330	Strap and bolt kit								2	2	2	2	2	2	2	2
22	424647	U-joint								2	2	2	2	2	2	2	2
23	162809	Zerk, grease fitting								2	2	2	2	2	2	2	2

6 AA 31

FRONT DRIVE AXLE PRE-INSTALLATION (FRAME LEVELING ONLY)

M30-2 L	M30-4 L	M30-2 H L	M30-4 H L
M40-2 L	M40-4 L	M40-2 H L	M40-4 H L
M50-2 L	M50-4 L	M50-2 H L	M50-4 H L
M60-2 L	M60-4 L	M60-2 H L	M60-4 H L

SEE AX2519A

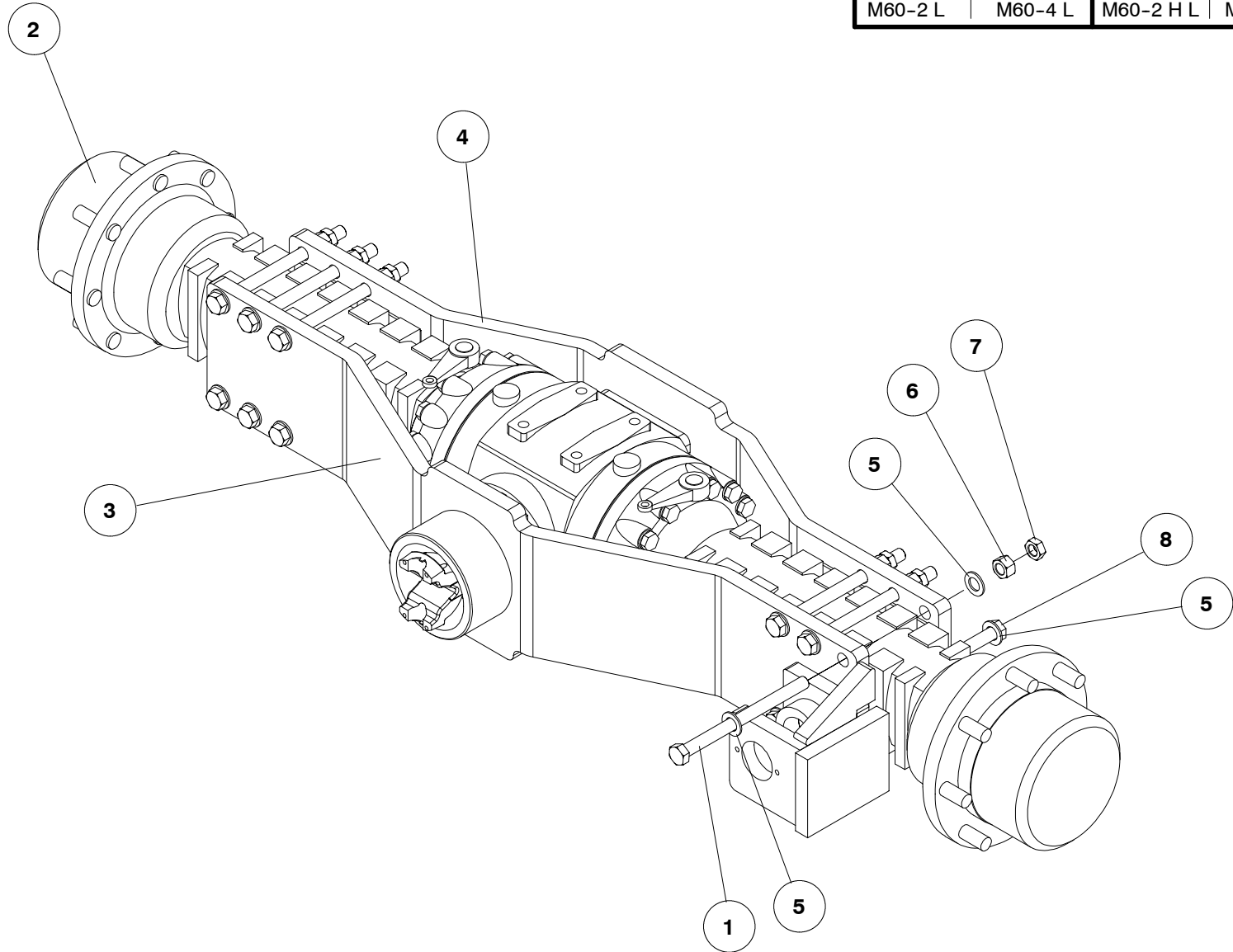

1	FRONT DRIVE AXLE PRE-INSTALLATION (FRAME LEVELING ONLY)		QUANTITY / MODEL								6 AA 31						
											M30-4 L	M40-4 L	M50-4 L	M60-4 L	M30-4 H L	M40-4 H L	M50-4 H L
ITEM	PART NO.	DESCRIPTION								M30-2 L	M40-2 L	M50-2 L	M60-2 L	M30-2 H L	M40-2 H L	M50-2 H L	M60-2 H L
1	426648	Bolt								10	10	10	10	10	10	10	10
2	801989	Drive axle, front								1	1	1	1	1	1	1	1
3	801966	Plate assembly, rear								1	1	1	1	1	1	1	1
4	801971	Plate assembly, front								1	1	1	1	1	1	1	1
5	426650	Washer, flat								22	22	22	22	22	22	22	22
6	426649	Nut								10	10	10	10	10	10	10	10
7	K34691	Nut								10	10	10	10	10	10	10	10
8	K58758	Bolt								2	2	2	2	2	2	2	2

6 AA 32

CYLINDER, FRAME LEVELING, INSTALLATION

M30-2 L	M30-4 L	M30-2 H L	M30-4 H L
M40-2 L	M40-4 L	M40-2 H L	M40-4 H L
M50-2 L	M50-4 L	M50-2 H L	M50-4 H L
M60-2 L	M60-4 L	M60-2 H L	M60-4 H L

CIRCUIT BREAKER COVER SHOWN FROM BACK

DRILL COVER POSITION
F20 Ø0.445

802523
WIRE HARNESS

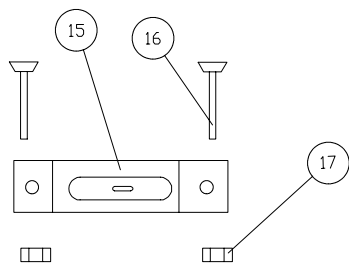

NOTE:
LEVEL INSTALLATION
1) PARK THE TRUCK ON FLAT GROUND.
2) CHECK LATERAL PLANARITY OF THE TRUCK USING LEVEL INDICATOR ON AT LEAST 3 PLANAR SURFACES. EX: FRAME OR FENDERS
3) ONCE TRUCK IS LEVELLED, INSTALL THE LEVEL GAUGE (#448834).

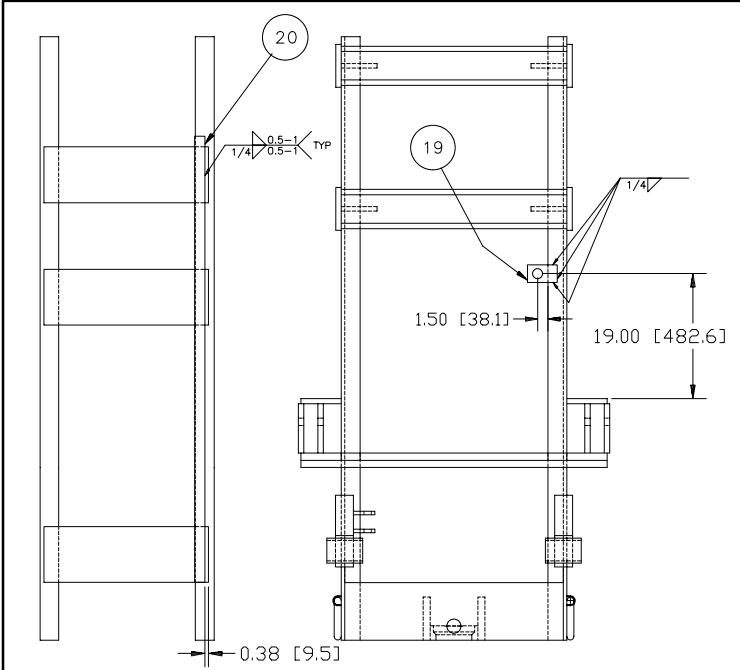
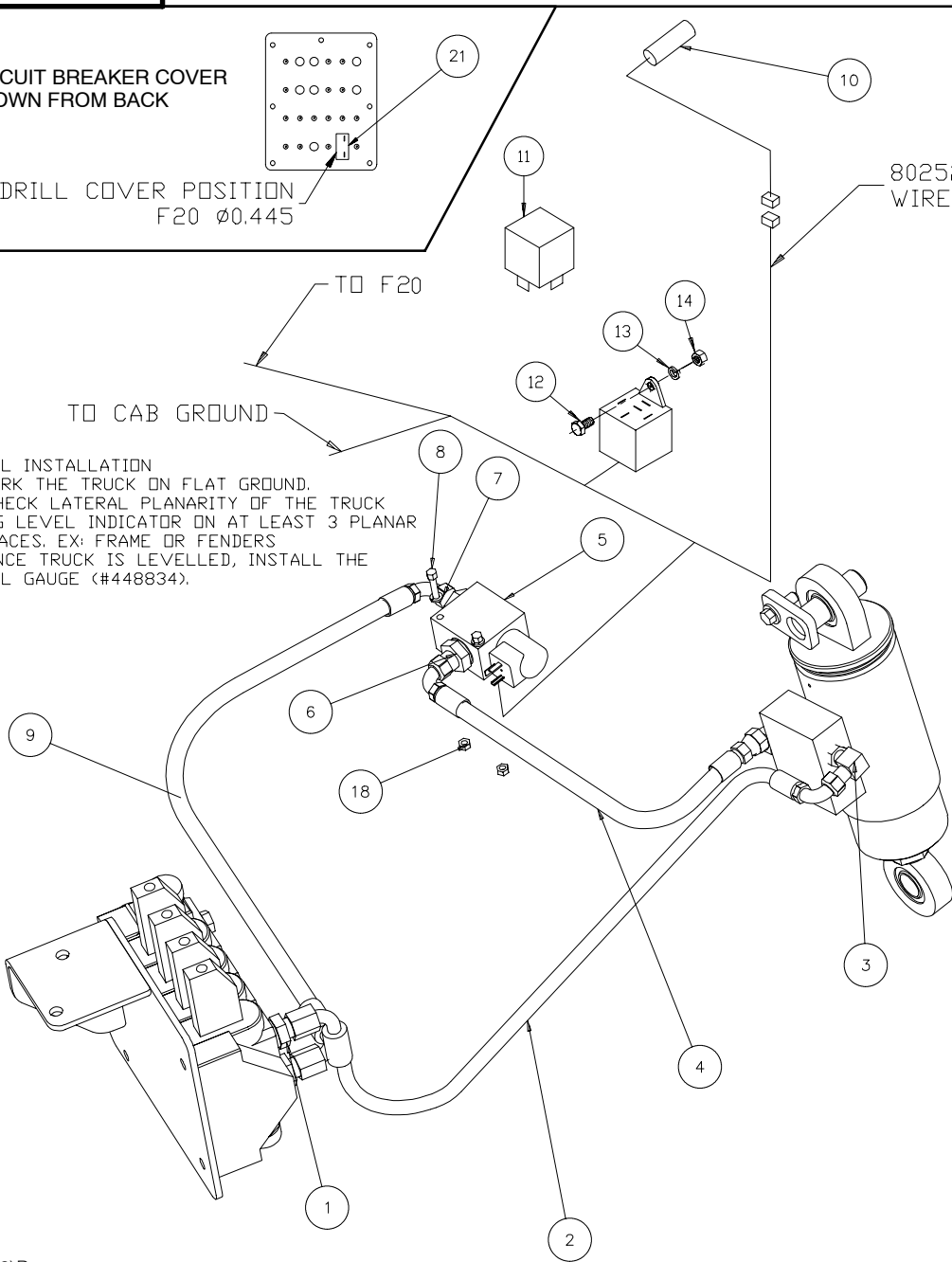

REAR VIEW OF K3606 INNER RAIL REAR VIEW OF K3606 OUTER RAIL

NOTE: POSITION PROXIMITY SWITCH SO THAT THE TRUCK WILL NOT FRAME LEVEL AFTER THE TOP OF THE LBR HAS PASSED THE TOP OF THE OUTER RAIL.

1	CYLINDER, FRAME LEVELING, INSTALLATION		QUANTITY / MODEL								6 AA 32						
											M30-4 L	M40-4 L	M50-4 L	M60-4 L	M30-4 H L	M40-4 H L	M50-4 H L
ITEM	PART NO.	DESCRIPTION								M30-2 L	M40-2 L	M50-2 L	M60-2 L	M30-2 H L	M40-2 H L	M50-2 H L	M60-2 H L
1	803288	Orifice assembly								2	2	2	2	2	2	2	2
2	803289	Hose assembly								1	1	1	1	1	1	1	1
3	M0001183	Adapter								2	2	2	2	2	2	2	2
4	803290	Hose assembly								1	1	1	1	1	1	1	1
5	224826	Valve, solenoid								1	1	1	1	1	1	1	1
6	803188	Connector								2	2	2	2	2	2	2	2
7	42316	Washer								2	2	2	2	2	2	2	2
8	31007	Screw								2	2	2	2	2	2	2	2
9	803291	Hose assembly								1	1	1	1	1	1	1	1
10	802932	Proximity switch								1	1	1	1	1	1	1	1
11	231244	Relay								1	1	1	1	1	1	1	1
12	79533	Screw								1	1	1	1	1	1	1	1
13	28959	Washer								1	1	1	1	1	1	1	1
14	54232	Nut								1	1	1	1	1	1	1	1
15	448834	Level indicator								1	1	1	1	1	1	1	1
16	478547	Screw								2	2	2	2	2	2	2	2
17	25758	Nut								2	2	2	2	2	2	2	2
18	25714	Nut								2	2	2	2	2	2	2	2
19	803042	Support, prox switch								1	1	1	1	1	1	1	1
20	804044	Flat								1	1	1	1	1	1	1	1
21	804285	Circuit breaker, 5A								1	1	1	1	1	1	1	1

6 BA 10

PARKING BRAKE ASSEMBLY, 100 IN. SEMI & ENCLOSED CABS

M30-2	M30-4	M30-2 H	M30-4 H
M40-2	M40-4	M40-2 H	M40-4 H
M50-2	M50-4	M50-2 H	M50-4 H
M60-2	M60-4	M60-2 H	M60-4 H
M30-2 L	M30-4 L	M30-2 H L	M30-4 H L
M40-2 L	M40-4 L	M40-2 H L	M40-4 H L
M50-2 L	M50-4 L	M50-2 H L	M50-4 H L
M60-2 L	M60-4 L	M60-2 H L	M60-4 H L

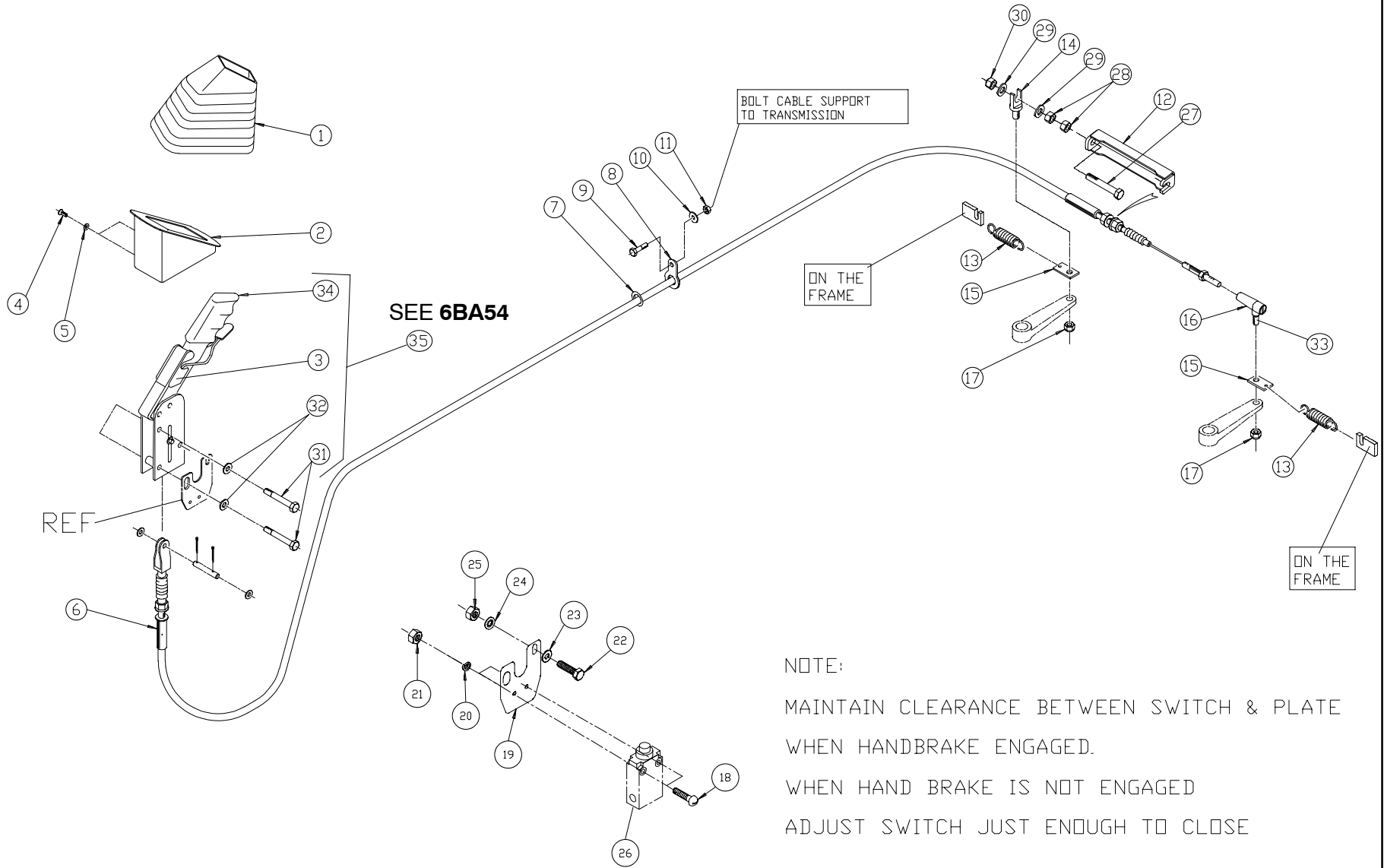

1	PARKING BRAKE ASSEMBLY, 100 IN. SEMI & ENCLOSED CABS		QUANTITY / MODEL											6 BA 10				
			M30-4	M40-4	M50-4	M60-4	M30-4 H	M40-4 H	M50-4 H	M60-4 H	M30-4 L	M40-4 L	M50-4 L	M60-4 L	M30-4 H L	M40-4 H L	M50-4 H L	M60-4 H L
ITEM	PART NO.	DESCRIPTION	M30-2	M40-2	M50-2	M60-2	M30-2 H	M40-2 H	M50-2 H	M60-2 H	M30-2 L	M40-2 L	M50-2 L	M60-2 L	M30-2 H L	M40-2 H L	M50-2 H L	M60-2 H L
1	243197	Bellow	1	1	1	1	1	1	1	1	1	1	1	1	1	1	1	1
2	226256	Bracket, bellows	1	1	1	1	1	1	1	1	1	1	1	1	1	1	1	1
3	243798	Handbrake, (less Item 34 lever cover)	1	1	1	1	1	1	1	1	1	1	1	1	1	1	1	1
4	196951	Screw	2	2	2	2	2	2	2	2	2	2	2	2	2	2	2	2
5	189857	Washer	2	2	2	2	2	2	2	2	2	2	2	2	2	2	2	2
6	237802	Cable, handbrake	1	1	1	1	1	1	1	1	1	1	1	1	1	1	1	1
7	235171	Grommet, cable	1	1	1	1	1	1	1	1	1	1	1	1	1	1	1	1
8	219180	Guide, cable	1	1	1	1	1	1	1	1	1	1	1	1	1	1	1	1
9	5804	Screw	1	1	1	1	1	1	1	1	1	1	1	1	1	1	1	1
10	183026	Washer	1	1	1	1	1	1	1	1	1	1	1	1	1	1	1	1
11	56354	Nut	1	1	1	1	1	1	1	1	1	1	1	1	1	1	1	1
12	233353	Bracket, cable adjustment	1	1	1	1	1	1	1	1	1	1	1	1	1	1	1	1
13	220645	Spring	2	2	2	2	2	2	2	2	2	2	2	2	2	2	2	2
14	514278	Fastener	1	1	1	1	1	1	1	1	1	1	1	1	1	1	1	1
15	164965	Fastening plate	2	2	2	2	2	2	2	2	2	2	2	2	2	2	2	2
16	58202	Cable end	1	1	1	1	1	1	1	1	1	1	1	1	1	1	1	1
17	55714	Nut	2	2	2	2	2	2	2	2	2	2	2	2	2	2	2	2
18	803450	Screw	2	2	2	2	2	2	2	2	2	2	2	2	2	2	2	2
19	803419	Plate, switch support	1	1	1	1	1	1	1	1	1	1	1	1	1	1	1	1
20	28987	Washer	2	2	2	2	2	2	2	2	2	2	2	2	2	2	2	2
21	25758	Nut	2	2	2	2	2	2	2	2	2	2	2	2	2	2	2	2
22	25713	Screw	1	1	1	1	1	1	1	1	1	1	1	1	1	1	1	1
23	29469	Washer	1	1	1	1	1	1	1	1	1	1	1	1	1	1	1	1
24	174132	Washer	1	1	1	1	1	1	1	1	1	1	1	1	1	1	1	1
25	25714	Nut	1	1	1	1	1	1	1	1	1	1	1	1	1	1	1	1
26	210792	Switch, parking brake	1	1	1	1	1	1	1	1	1	1	1	1	1	1	1	1
27	223481	Screw	1	1	1	1	1	1	1	1	1	1	1	1	1	1	1	1
28	58548	Nut	2	2	2	2	2	2	2	2	2	2	2	2	2	2	2	2

6 BA 20

PARKING BRAKE ASSEMBLY, EXCEPT 100 IN. SEMI & ENCLOSED CABS

M30-2	M30-4	M30-2 H	M30-4 H
M40-2	M40-4	M40-2 H	M40-4 H
M50-2	M50-4	M50-2 H	M50-4 H
M60-2	M60-4	M60-2 H	M60-4 H
M30-2 L	M30-4 L	M30-2 H L	M30-4 H L
M40-2 L	M40-4 L	M40-2 H L	M40-4 H L
M50-2 L	M50-4 L	M50-2 H L	M50-4 H L
M60-2 L	M60-4 L	M60-2 H L	M60-4 H L

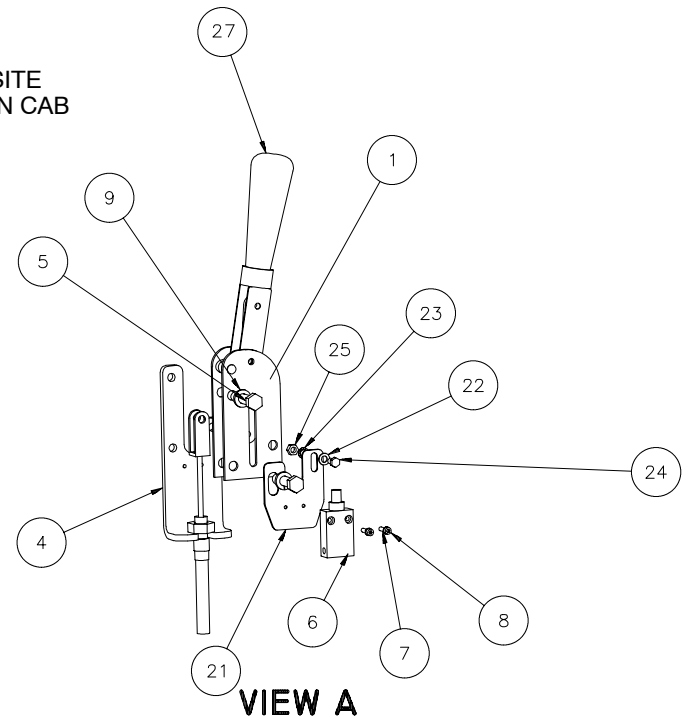
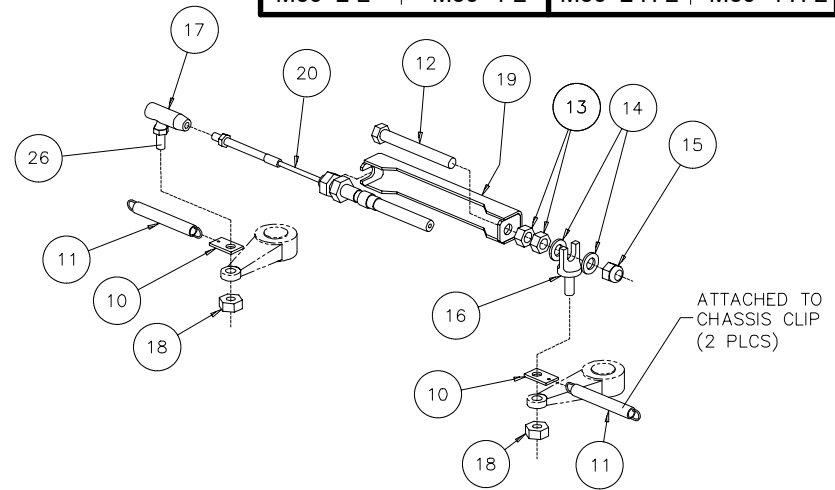
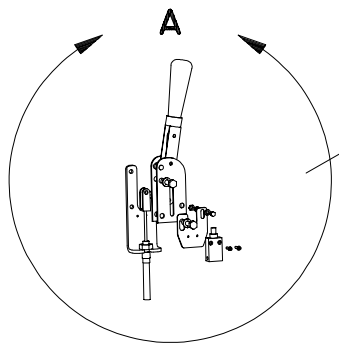
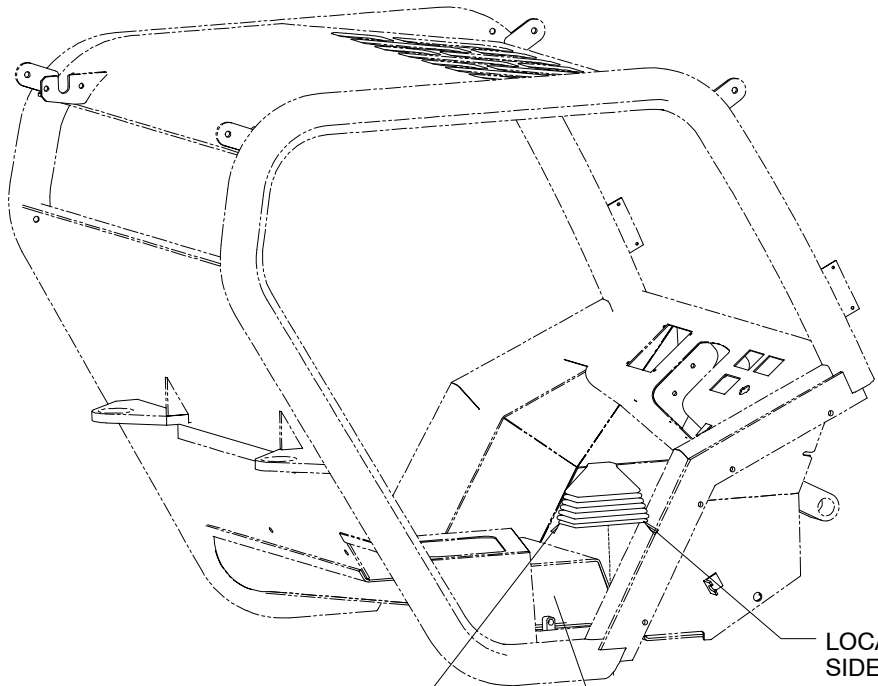

1	PARKING BRAKE ASSEMBLY, EXCEPT 100 IN. SEMI & ENCLOSED CABS		QUANTITY / MODEL												6 BA 20			
			M30-4	M40-4	M50-4	M60-4	M30-4 H	M40-4 H	M50-4 H	M60-4 H	M30-4 L	M40-4 L	M50-4 L	M60-4 L	M30-4 H L	M40-4 H L	M50-4 H L	M60-4 H L
			M30-2	M40-2	M50-2	M60-2	M30-2 H	M40-2 H	M50-2 H	M60-2 H	M30-2 L	M40-2 L	M50-2 L	M60-2 L	M30-2 H L	M40-2 H L	M50-2 H L	M60-2 H L
ITEM	PART NO.	DESCRIPTION	M30-2	M40-2	M50-2	M60-2	M30-2 H	M40-2 H	M50-2 H	M60-2 H	M30-2 L	M40-2 L	M50-2 L	M60-2 L	M30-2 H L	M40-2 H L	M50-2 H L	M60-2 H L
1	243798	Brake handle assembly, less lever cover	1	1	1	1	1	1	1	1	1	1	1	1	1	1	1	1
3	243197	Bellows	1	1	1	1	1	1	1	1	1	1	1	1	1	1	1	1
4	802719	Cable mount	1	1	1	1	1	1	1	1	1	1	1	1	1	1	1	1
5	58536	Bolt	3	3	3	3	3	3	3	3	3	3	3	3	3	3	3	3
6	210792	Switch	1	1	1	1	1	1	1	1	1	1	1	1	1	1	1	1
7	28987	Washer	2	2	2	2	2	2	2	2	2	2	2	2	2	2	2	2
8	803450	Screw	2	2	2	2	2	2	2	2	2	2	2	2	2	2	2	2
9	42232	Washer	3	3	3	3	3	3	3	3	3	3	3	3	3	3	3	3
10	164965	Clip, spring	2	2	2	2	2	2	2	2	2	2	2	2	2	2	2	2
11	220645	Spring	2	2	2	2	2	2	2	2	2	2	2	2	2	2	2	2
12	223481	Bolt	1	1	1	1	1	1	1	1	1	1	1	1	1	1	1	1
13	58548	Nut	2	2	2	2	2	2	2	2	2	2	2	2	2	2	2	2
14	61676	Washer	2	2	2	2	2	2	2	2	2	2	2	2	2	2	2	2
15	44672	Nut	1	1	1	1	1	1	1	1	1	1	1	1	1	1	1	1
16	514278	Cable clip	1	1	1	1	1	1	1	1	1	1	1	1	1	1	1	1
17	58202	Cable end	1	1	1	1	1	1	1	1	1	1	1	1	1	1	1	1
18	55714	Nut	2	2	2	2	2	2	2	2	2	2	2	2	2	2	2	2
19	233353	Bracket, cable adjustment	1	1	1	1	1	1	1	1	1	1	1	1	1	1	1	1
20	237802	Cable, brake	1	1	1	1	1	1	1	1	1	1	1	1	1	1	1	1
21	803419	Plate, switch mount	1	1	1	1	1	1	1	1	1	1	1	1	1	1	1	1
22	29469	Washer, flat	1	1	1	1	1	1	1	1	1	1	1	1	1	1	1	1
23	174132	Washer, lock	1	1	1	1	1	1	1	1	1	1	1	1	1	1	1	1
24	25713	Screw	1	1	1	1	1	1	1	1	1	1	1	1	1	1	1	1
25	25714	Nut	1	1	1	1	1	1	1	1	1	1	1	1	1	1	1	1
26	514279	Knee joint	1	1	1	1	1	1	1	1	1	1	1	1	1	1	1	1
27	563550	Lever cover	1	1	1	1	1	1	1	1	1	1	1	1	1	1	1	1

6 BA 54

PARKING BRAKE LEVER, 100 IN. SEMI AND ENCLOSED CABS

M30-2	M30-4	M30-2 H	M30-4 H
M40-2	M40-4	M40-2 H	M40-4 H
M50-2	M50-4	M50-2 H	M50-4 H
M60-2	M60-4	M60-2 H	M60-4 H
M30-2 L	M30-4 L	M30-2 H L	M30-4 H L
M40-2 L	M40-4 L	M40-2 H L	M40-4 H L
M50-2 L	M50-4 L	M50-2 H L	M50-4 H L
M60-2 L	M60-4 L	M60-2 H L	M60-4 H L

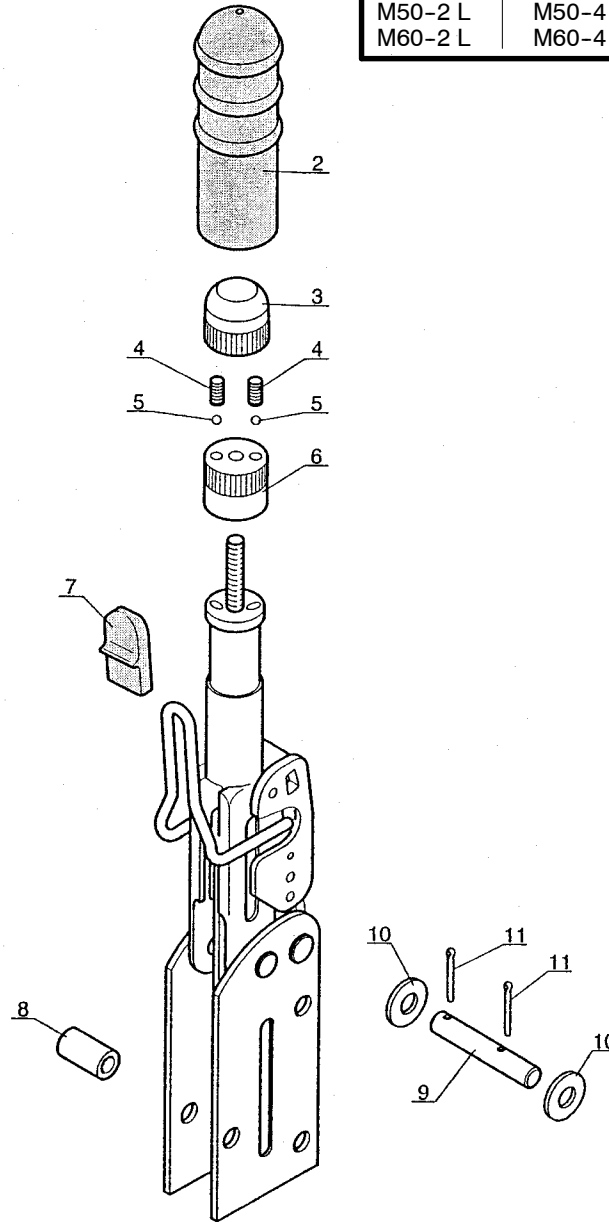
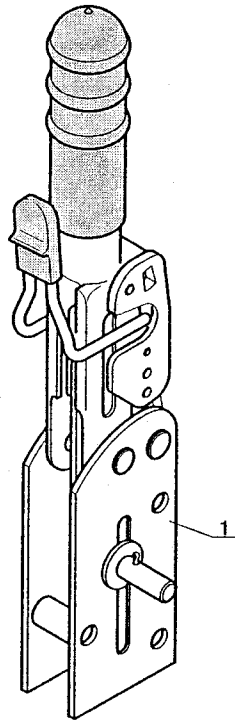

ITEM	PART NO.	DESCRIPTION	QUANTITY / MODEL												6 BA 54			
			M30-2	M40-2	M50-2	M60-2	M30-2 H	M40-2 H	M50-2 H	M60-2 H	M30-2 L	M40-2 L	M50-2 L	M60-2 L	M30-4 H L	M40-4 H L	M50-4 H L	M60-4 H L
1		PARKING BRAKE LEVER, 100 IN. SEMI AND ENCLOSED CABS	M30-4	M40-4	M50-4	M60-4	M30-4 H	M40-4 H	M50-4 H	M60-4 H	M30-4 L	M40-4 L	M50-4 L	M60-4 L	M30-4 H L	M40-4 H L	M50-4 H L	M60-4 H L
1	225199	Handbrake, complete	1	1	1	1	1	1	1	1	1	1	1	1	1	1	1	1
2	563550	Handle	1	1	1	1	1	1	1	1	1	1	1	1	1	1	1	1
3	563551	Button	1	1	1	1	1	1	1	1	1	1	1	1	1	1	1	1
4	49370	Spring	2	2	2	2	2	2	2	2	2	2	2	2	2	2	2	2
5	49369	Ball	2	2	2	2	2	2	2	2	2	2	2	2	2	2	2	2
6	563552	Button	1	1	1	1	1	1	1	1	1	1	1	1	1	1	1	1
7	563553	Cap	1	1	1	1	1	1	1	1	1	1	1	1	1	1	1	1
8	49330	Spacer	3	3	3	3	3	3	3	3	3	3	3	3	3	3	3	3
9	563447	Axle	1	1	1	1	1	1	1	1	1	1	1	1	1	1	1	1
10	563448	Washer	2	2	2	2	2	2	2	2	2	2	2	2	2	2	2	2
11	563449	Pin	2	2	2	2	2	2	2	2	2	2	2	2	2	2	2	2

6 BB 10

BRAKE SYSTEM ASSEMBLY, HYDRAULIC, 100 IN. CAB ONLY

M30-2	M30-4	M30-2 H	M30-4 H
M40-2	M40-4	M40-2 H	M40-4 H
M50-2	M50-4	M50-2 H	M50-4 H
M60-2	M60-4	M60-2 H	M60-4 H
M30-2 L	M30-4 L	M30-2 H L	M30-4 H L
M40-2 L	M40-4 L	M40-2 H L	M40-4 H L
M50-2 L	M50-4 L	M50-2 H L	M50-4 H L
M60-2 L	M60-4 L	M60-2 H L	M60-4 H L

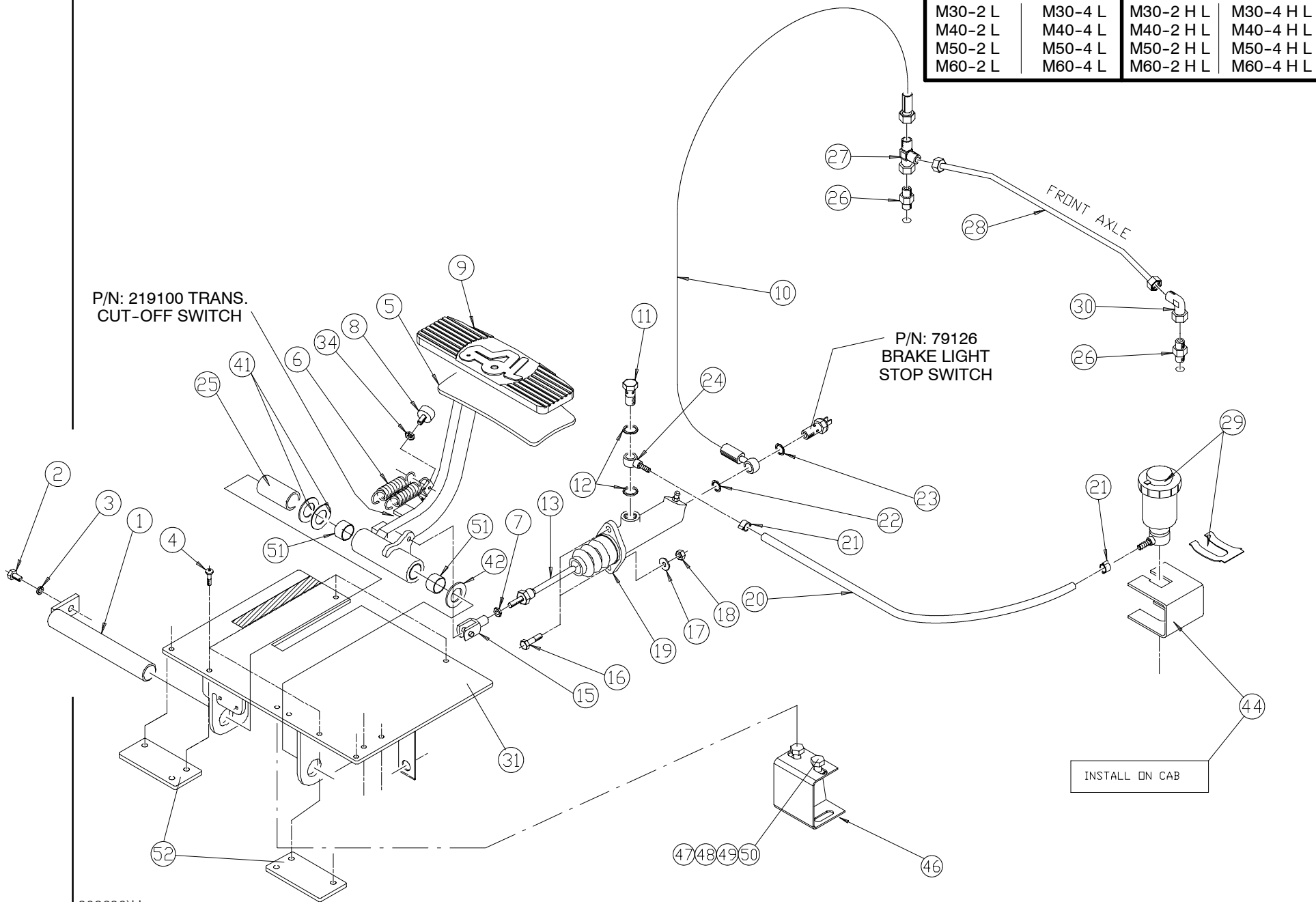

1	BRAKE SYSTEM ASSEMBLY, HYDRAULIC, 100 IN. CAB ONLY		QUANTITY / MODEL												6 BB 10			
			M30-4	M40-4	M50-4	M60-4	M30-4 H	M40-4 H	M50-4 H	M60-4 H	M30-4 L	M40-4 L	M50-4 L	M60-4 L	M30-4 H L	M40-4 H L	M50-4 H L	M60-4 H L
ITEM	PART NO.	DESCRIPTION	M30-2	M40-2	M50-2	M60-2	M30-2 H	M40-2 H	M50-2 H	M60-2 H	M30-2 L	M40-2 L	M50-2 L	M60-2 L	M30-2 H L	M40-2 H L	M50-2 H L	M60-2 H L
1	79412	Pedal axle	1	1	1	1	1	1	1	1	1	1	1	1	1	1	1	1
2	54951	Bolt	1	1	1	1	1	1	1	1	1	1	1	1	1	1	1	1
3	42325	Washer	1	1	1	1	1	1	1	1	1	1	1	1	1	1	1	1
4	189172	Bolt	A/R	A/R	A/R	A/R	A/R	A/R	A/R	A/R	A/R	A/R	A/R	A/R	A/R	A/R	A/R	A/R
5	802780	Brake pedal	1	1	1	1	1	1	1	1	1	1	1	1	1	1	1	1
6	5398	Spring	2	2	2	2	2	2	2	2	2	2	2	2	2	2	2	2
7	3212	Nut	1	1	1	1	1	1	1	1	1	1	1	1	1	1	1	1
8	53501	Rubber stop	1	1	1	1	1	1	1	1	1	1	1	1	1	1	1	1
9	406017	Pad, pedal cover	1	1	1	1	1	1	1	1	1	1	1	1	1	1	1	1
10	217947	Brake hose	1	1	1	1	1	1	1	1	1	1	1	1	1	1	1	1
11	218074	Bolt, hollow	1	1	1	1	1	1	1	1	1	1	1	1	1	1	1	1
12	80305	Seal	2	2	2	2	2	2	2	2	2	2	2	2	2	2	2	2
13	78237	Master cylinder rod	1	1	1	1	1	1	1	1	1	1	1	1	1	1	1	1
15	81047	Short clevis	1	1	1	1	1	1	1	1	1	1	1	1	1	1	1	1
16	K20386SS	Bolt	2	2	2	2	2	2	2	2	2	2	2	2	2	2	2	2
17	K34806SS	Washer	2	2	2	2	2	2	2	2	2	2	2	2	2	2	2	2
18	K33922	Nut	1	1	1	1	1	1	1	1	1	1	1	1	1	1	1	1
19	78179	Master cylinder	1	1	1	1	1	1	1	1	1	1	1	1	1	1	1	1
20	802781	Hose	1	1	1	1	1	1	1	1	1	1	1	1	1	1	1	1
21	479218	Hose clamp	2	2	2	2	2	2	2	2	2	2	2	2	2	2	2	2
22	233837	Seal	1	1	1	1	1	1	1	1	1	1	1	1	1	1	1	1
23	81044	Seal	1	1	1	1	1	1	1	1	1	1	1	1	1	1	1	1
24	218075	Banjo fitting	1	1	1	1	1	1	1	1	1	1	1	1	1	1	1	1
25	79414	Tube	1	1	1	1	1	1	1	1	1	1	1	1	1	1	1	1
26	175498	Fitting	2	2	2	2	2	2	2	2	2	2	2	2	2	2	2	2
27	190442	Tee fitting	1	1	1	1	1	1	1	1	1	1	1	1	1	1	1	1
28	237806	Tube assembly	1	1	1	1	1	1	1	1	1	1	1	1	1	1	1	1

2	BRAKE SYSTEM ASSEMBLY, HYDRAULIC, 100 IN. CAB ONLY		QUANTITY / MODEL											6 BB 10				
			M30-4	M40-4	M50-4	M60-4	M30-4 H	M40-4 H	M50-4 H	M60-4 H	M30-4 L	M40-4 L	M50-4 L	M60-4 L	M30-4 H L	M40-4 H L	M50-4 H L	M60-4 H L
ITEM	PART NO.	DESCRIPTION	M30-2	M40-2	M50-2	M60-2	M30-2 H	M40-2 H	M50-2 H	M60-2 H	M30-2 L	M40-2 L	M50-2 L	M60-2 L	M30-2 H L	M40-2 H L	M50-2 H L	M60-2 H L
29	219559	Brake reservoir	1	1	1	1	1	1	1	1	1	1	1	1	1	1	1	1
30	497922	Fitting	1	1	1	1	1	1	1	1	1	1	1	1	1	1	1	1
31A*	802778	Brake pedal support bracket	1	1	1	1	1	1	1	1	1	1	1	1	1	1	1	1
31B**	803762	Brake pedal support bracket	1	1	1	1	1	1	1	1	1	1	1	1	1	1	1	1
33	29469	Washer	3	3	3	3	3	3	3	3	3	3	3	3	3	3	3	3
34	162229	Nut	1	1	1	1	1	1	1	1	1	1	1	1	1	1	1	1
41	U43217-10110-71	Washer	3	3	3	3	3	3	3	3	3	3	3	3	3	3	3	3
42	220370	Washer	1	1	1	1	1	1	1	1	1	1	1	1	1	1	1	1
44	802976	Master cylinder bracket	1	1	1	1	1	1	1	1	1	1	1	1	1	1	1	1
46	802704	Bracket	1	1	1	1	1	1	1	1	1	1	1	1	1	1	1	1
47	42347	Bolt	2	2	2	2	2	2	2	2	2	2	2	2	2	2	2	2
48	61674	Washer	2	2	2	2	2	2	2	2	2	2	2	2	2	2	2	2
49	42325	Washer	2	2	2	2	2	2	2	2	2	2	2	2	2	2	2	2
50	58528	Nut	2	2	2	2	2	2	2	2	2	2	2	2	2	2	2	2
51	172569	Brake bushing	2	2	2	2	2	2	2	2	2	2	2	2	2	2	2	2
52**	803732	Plate, support	2	2	2	2	2	2	2	2	2	2	2	2	2	2	2	2

* S/N: 750185 & below, except 750168 & 750182

** S/N: 750168, 750182, 750185 & above

ACCELERATOR PEDAL ASSEMBLY, 100 IN. CAB ONLY

M30-2	M30-4	M30-2 H	M30-4 H
M40-2	M40-4	M40-2 H	M40-4 H
M50-2	M50-4	M50-2 H	M50-4 H
M60-2	M60-4	M60-2 H	M60-4 H
M30-2 L	M30-4 L	M30-2 H L	M30-4 H L
M40-2 L	M40-4 L	M40-2 H L	M40-4 H L
M50-2 L	M50-4 L	M50-2 H L	M50-4 H L
M60-2 L	M60-4 L	M60-2 H L	M60-4 H L

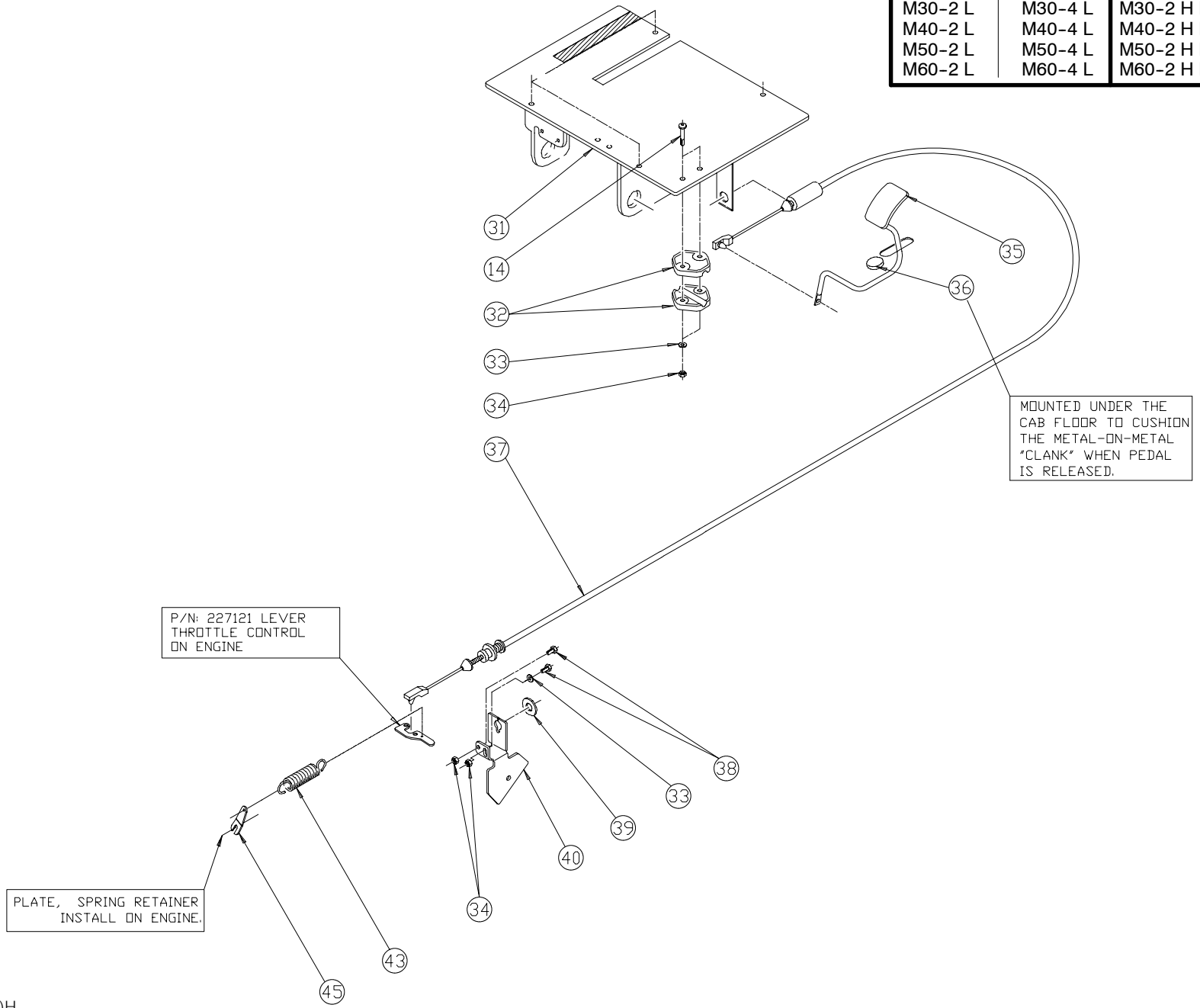

P/N: 227121 LEVER
THROTTLE CONTROL
ON ENGINE

PLATE, SPRING RETAINER
INSTALL ON ENGINE.

MOUNTED UNDER THE
CAB FLOOR TO CUSHION
THE METAL-ON-METAL
'CLANK' WHEN PEDAL
IS RELEASED.

1	ACCELERATOR PEDAL ASSEMBLY, 100 IN. CAB ONLY												6 BB 11						
	ITEM	PART NO.	DESCRIPTION	M30-2	M40-2	M50-2	M60-2	M30-2 H	M40-2 H	M50-2 H	M60-2 H	M30-2 L	M40-2 L	M50-2 L	M60-2 L	M30-4 H L	M40-4 H L	M50-4 H L	M60-4 H L
14	190807	Bolt	2	2	2	2	2	2	2	2	2	2	2	2	2	2	2	2	2
32	77957	Clamp, bushing half	2	2	2	2	2	2	2	2	2	2	2	2	2	2	2	2	2
33	29469	Washer	3	3	3	3	3	3	3	3	3	3	3	3	3	3	3	3	3
34	162229	Nut	4	4	4	4	4	4	4	4	4	4	4	4	4	4	4	4	4
35	218013	Accelerator pedal	1	1	1	1	1	1	1	1	1	1	1	1	1	1	1	1	1
36	184130	Rubber arrestor	1	1	1	1	1	1	1	1	1	1	1	1	1	1	1	1	1
37	185580	Accelerator cable	1	1	1	1	1	1	1	1	1	1	1	1	1	1	1	1	1
38	25713	Bolt	2	2	2	2	2	2	2	2	2	2	2	2	2	2	2	2	2
39	61680	Washer	1	1	1	1	1	1	1	1	1	1	1	1	1	1	1	1	1
40	224861	Accelerator cable bracket	1	1	1	1	1	1	1	1	1	1	1	1	1	1	1	1	1
43	P3175H001	Spring	1	1	1	1	1	1	1	1	1	1	1	1	1	1	1	1	1
45	236096	Plate, spring retainer	1	1	1	1	1	1	1	1	1	1	1	1	1	1	1	1	1

6 BB 20

BRAKE SYSTEM ASSEMBLY, HYDRAULIC, 77 & 81 IN. CAB

M30-2	M30-4	M30-2 H	M30-4 H
M40-2	M40-4	M40-2 H	M40-4 H
M50-2	M50-4	M50-2 H	M50-4 H
M60-2	M60-4	M60-2 H	M60-4 H
M30-2 L	M30-4 L	M30-2 H L	M30-4 H L
M40-2 L	M40-4 L	M40-2 H L	M40-4 H L
M50-2 L	M50-4 L	M50-2 H L	M50-4 H L
M60-2 L	M60-4 L	M60-2 H L	M60-4 H L

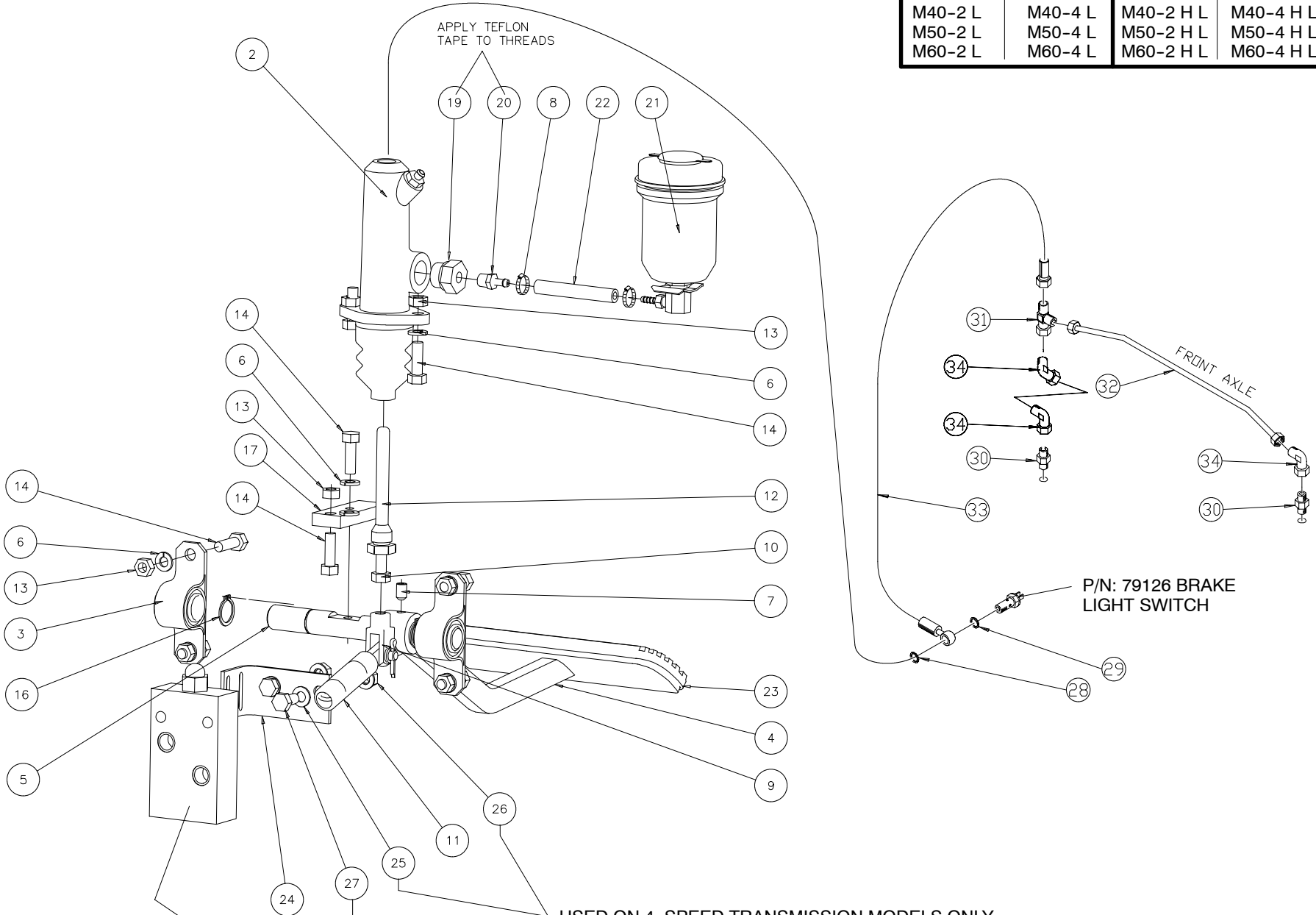

SHOWN FOR REF. ONLY, USED ON HYDROSTATIC TRANSMISSION MODELS ONLY

1	BRAKE SYSTEM ASSEMBLY, HYDRAULIC, 77 & 81 IN. CAB		QUANTITY / MODEL											6 BB 20				
			M30-4	M40-4	M50-4	M60-4	M30-4 H	M40-4 H	M50-4 H	M60-4 H	M30-4 L	M40-4 L	M50-4 L	M60-4 L	M30-4 H L	M40-4 H L	M50-4 H L	M60-4 H L
ITEM	PART NO.	DESCRIPTION	M30-2	M40-2	M50-2	M60-2	M30-2 H	M40-2 H	M50-2 H	M60-2 H	M30-2 L	M40-2 L	M50-2 L	M60-2 L	M30-2 H L	M40-2 H L	M50-2 H L	M60-2 H L
2	78179	Brake master cylinder	1	1	1	1	1	1	1	1	1	1	1	1	1	1	1	1
3	801864	Bearing block	2	2	2	2	2	2	2	2	2	2	2	2	2	2	2	2
4	802876	Brake pedal	1	1	1	1	1	1	1	1	1	1	1	1	1	1	1	1
5	801885	Pin, brake assembly	1	1	1	1	1	1	1	1	1	1	1	1	1	1	1	1
6	K34806SS	Washer	7	7	7	7	7	7	7	7	7	7	7	7	7	7	7	7
7	K89778	Screw	2	2	2	2	2	2	2	2	2	2	2	2	2	2	2	2
8	479218	Clamp	1	1	1	1	1	1	1	1	1	1	1	1	1	1	1	1
9	81047	Clevis assembly	1	1	1	1	1	1	1	1	1	1	1	1	1	1	1	1
10	3212	Nut	1	1	1	1	1	1	1	1	1	1	1	1	1	1	1	1
11	5398	Spring	1	1	1	1	1	1	1	1	1	1	1	1	1	1	1	1
12	78237	Master cylinder rod	1	1	1	1	1	1	1	1	1	1	1	1	1	1	1	1
13	K33922	Nut	7	7	7	7	7	7	7	7	7	7	7	7	7	7	7	7
14	K20386SS	Bolt	8	8	8	8	8	8	8	8	8	8	8	8	8	8	8	8
15	-----	Omitted																
16	K97524	Ring	2	2	2	2	2	2	2	2	2	2	2	2	2	2	2	2
17	801886	Tab, inching valve	1	1	1	1	1	1	1	1	1	1	1	1	1	1	1	1
18	-----	Omitted																
19	802054	Adapter	1	1	1	1	1	1	1	1	1	1	1	1	1	1	1	1
20	B3500	Adapter	1	1	1	1	1	1	1	1	1	1	1	1	1	1	1	1
21	219559	Reservoir, brake fluid	1	1	1	1	1	1	1	1	1	1	1	1	1	1	1	1
22	802779	Hose	1	1	1	1	1	1	1	1	1	1	1	1	1	1	1	1
23	406017	Pad, pedal cover	1	1	1	1	1	1	1	1	1	1	1	1	1	1	1	1
24	802010	Angle	1	1	1	1	1	1	1	1	1	1	1	1	1	1	1	1
25	61674	Washer	4	4	4	4	4	4	4	4	4	4	4	4	4	4	4	4
26	58528	Nut	2	2	2	2	2	2	2	2	2	2	2	2	2	2	2	2
27	54951	Bolt	2	2	2	2	2	2	2	2	2	2	2	2	2	2	2	2
28	233837	Seal	1	1	1	1	1	1	1	1	1	1	1	1	1	1	1	1

6 BB 21

ACCELERATOR PEDAL ASSEMBLY, 77 & 81 IN. CAB

M30-2	M30-4	M30-2 H	M30-4 H
M40-2	M40-4	M40-2 H	M40-4 H
M50-2	M50-4	M50-2 H	M50-4 H
M60-2	M60-4	M60-2 H	M60-4 H
M30-2 L	M30-4 L	M30-2 H L	M30-4 H L
M40-2 L	M40-4 L	M40-2 H L	M40-4 H L
M50-2 L	M50-4 L	M50-2 H L	M50-4 H L
M60-2 L	M60-4 L	M60-2 H L	M60-4 H L

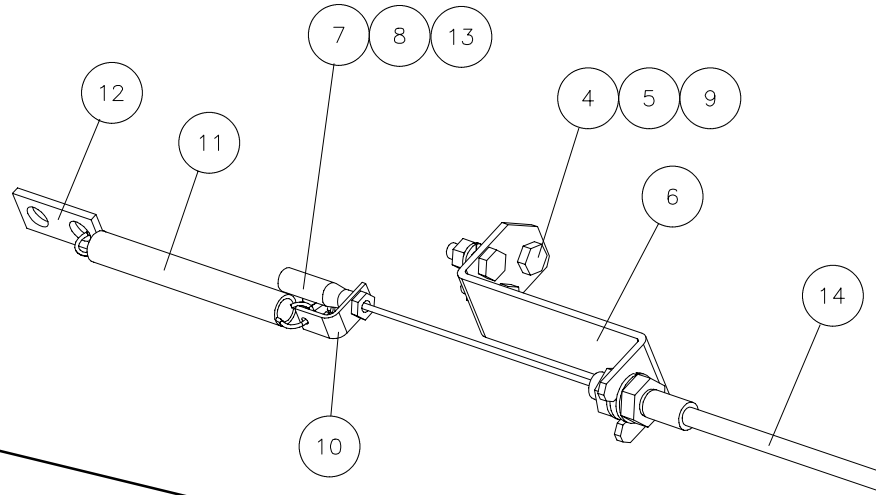

**ENGINE THROTTLE
NO CHANGES**

**1ST MOUNTING
THROTTLE PEDAL
S/N: 750480 & BELOW**

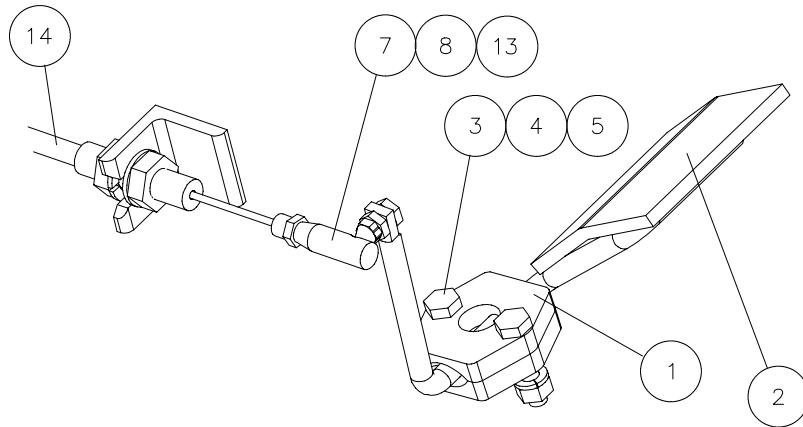

**2ND MOUNTING
THROTTLE PEDAL
S/N: 750481 & ABOVE**

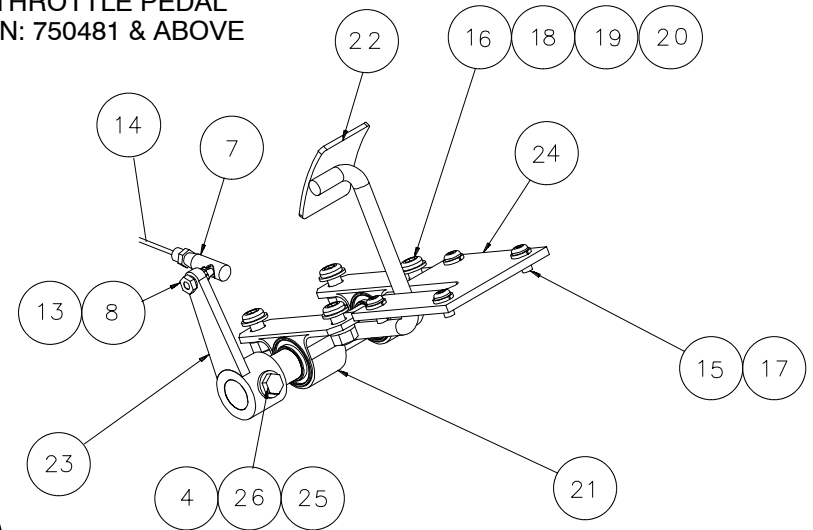

1	ACCELERATOR PEDAL ASSEMBLY, 77 & 81 IN. CAB		QUANTITY / MODEL												6 BB 21			
			M30-4	M40-4	M50-4	M60-4	M30-4 H	M40-4 H	M50-4 H	M60-4 H	M30-4 L	M40-4 L	M50-4 L	M60-4 L	M30-4 H L	M40-4 H L	M50-4 H L	M60-4 H L
ITEM	PART NO.	DESCRIPTION	M30-2	M40-2	M50-2	M60-2	M30-2 H	M40-2 H	M50-2 H	M60-2 H	M30-2 L	M40-2 L	M50-2 L	M60-2 L	M30-2 H L	M40-2 H L	M50-2 H L	M60-2 H L
1	77957	Pad, plastic	2	2	2	2	2	2	2	2	2	2	2	2	2	2	2	2
2	496647	Pedal, accelerator	1	1	1	1	1	1	1	1	1	1	1	1	1	1	1	1
3	K20424	Bolt	2	2	2	2	2	2	2	2	2	2	2	2	2	2	2	2
4	493789	Nut	5	5	5	5	5	5	5	5	5	5	5	5	5	5	5	5
5	K34805	Washer	5	5	5	5	5	5	5	5	5	5	5	5	5	5	5	5
6	496718	Mounting bracket, accelerator	1	1	1	1	1	1	1	1	1	1	1	1	1	1	1	1
7	421481	Connector, accelerator cable	2	2	2	2	2	2	2	2	2	2	2	2	2	2	2	2
8	K34079	Nut	4	4	4	4	4	4	4	4	4	4	4	4	4	4	4	4
9	K20344	Bolt	3	3	3	3	3	3	3	3	3	3	3	3	3	3	3	3
10	425316	Bracket, spring	1	1	1	1	1	1	1	1	1	1	1	1	1	1	1	1
11	B1074	Spring	1	1	1	1	1	1	1	1	1	1	1	1	1	1	1	1
12	425340	Clip, spring	1	1	1	1	1	1	1	1	1	1	1	1	1	1	1	1
13	K34779	Washer	2	2	2	2	2	2	2	2	2	2	2	2	2	2	2	2
14	424947	Cable, accelerator	1	1	1	1	1	1	1	1	1	1	1	1	1	1	1	1
15	196951	Screw	4	4	4	4	4	4	4	4	4	4	4	4	4	4	4	4
16	202144	Screw	4	4	4	4	4	4	4	4	4	4	4	4	4	4	4	4
17	42316	Washer	4	4	4	4	4	4	4	4	4	4	4	4	4	4	4	4
18	42325	Washer	4	4	4	4	4	4	4	4	4	4	4	4	4	4	4	4
19	58528	Nut	4	4	4	4	4	4	4	4	4	4	4	4	4	4	4	4
20	61674	Washer	4	4	4	4	4	4	4	4	4	4	4	4	4	4	4	4
21	801864	Bearing	2	2	2	2	2	2	2	2	2	2	2	2	2	2	2	2
22	804222	Pedal	1	1	1	1	1	1	1	1	1	1	1	1	1	1	1	1
23	804225	Arm	1	1	1	1	1	1	1	1	1	1	1	1	1	1	1	1
24	804278	Cover	1	1	1	1	1	1	1	1	1	1	1	1	1	1	1	1
25	K300858	Bolt	1	1	1	1	1	1	1	1	1	1	1	1	1	1	1	1
26	K44719	Washer	2	2	2	2	2	2	2	2	2	2	2	2	2	2	2	2

7 AA 10

STEERING AXLE AND HANGER INSTALLATION, 2WD

M30-2	M30-2 H
M40-2	M40-2 H
M50-2	M50-2 H
M60-2	M60-2 H
M30-2 L	M30-2 H L
M40-2 L	M40-2 H L
M50-2 L	M50-2 H L
M60-2 L	M60-2 H L

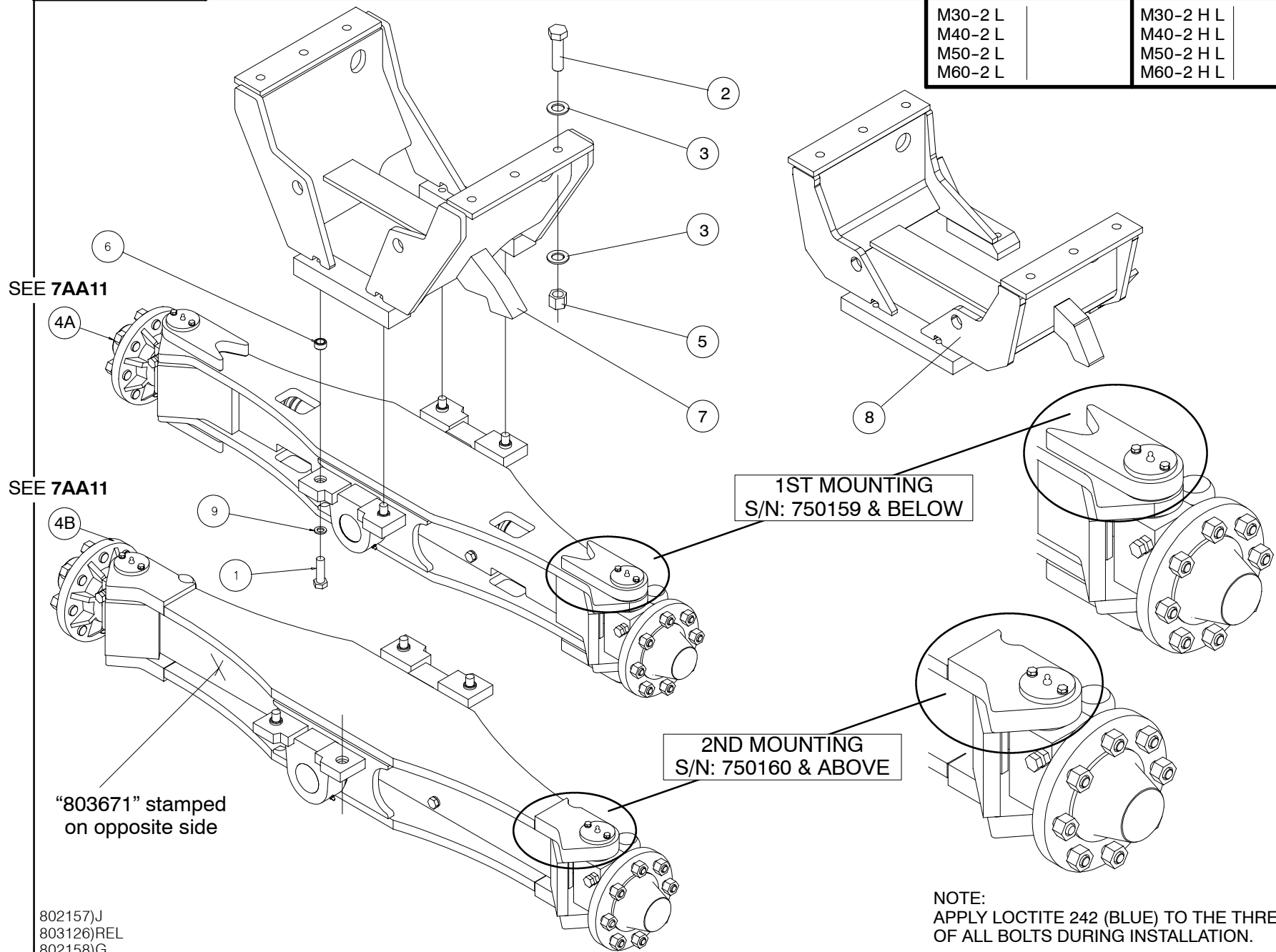

SEE 7AA11

SEE 7AA11

"803671" stamped on opposite side

802157)J
803126)REL
802158)G

NOTE:
APPLY LOCTITE 242 (BLUE) TO THE THREADS OF ALL BOLTS DURING INSTALLATION.

1	QUANTITY / MODEL													7 AA 10					
	ITEM	PART NO.	DESCRIPTION	M30-2	M40-2	M50-2	M60-2	M30-2 H	M40-2 H	M50-2 H	M60-2 H	M30-2 L	M40-2 L	M50-2 L	M60-2 L	M30-2 HL	M40-2 HL	M50-2 HL	M60-2 HL
			STEERING AXLE AND HANGER INSTALLATION, 2WD																
1	KW501303	Bolt		4	4	4	4	4	4	4	4	4	4	4	4	4	4	4	4
2	426688	Bolt		6	6	6	6	6	6	6	6	6	6	6	6	6	6	6	6
3	426650	Washer		12	12	12	12	12	12	12	12	12	12	12	12	12	12	12	12
4A	803284	Steer axle, S/N: 750159 & below		1	1	1	1	1	1	1	1	1	1	1	1	1	1	1	1
4B	803671	Steer axle, S/N: 750160 & above		1	1	1	1	1	1	1	1	1	1	1	1	1	1	1	1
5	R32	Nut		6	6	6	6	6	6	6	6	6	6	6	6	6	6	6	6
6	246073	Bushing, centering		4	4	4	4	4	4	4	4	4	4	4	4	4	4	4	4
7	801931	Axle hanger, 81" and 100" cabs		1	1	1	1	1	1	1	1	1	1	1	1	1	1	1	1
8	801930	Axle hanger, 77" cabs		1	1	1	1	1	1	1	1	1	1	1	1	1	1	1	1
9	61683	Washer		4	4	4	4	4	4	4	4	4	4	4	4	4	4	4	4

7 AA 11

STEER AXLE, 2WD

M30-2	M30-2 H
M40-2	M40-2 H
M50-2	M50-2 H
M60-2	M60-2 H
M30-2 L	M30-2 H L
M40-2 L	M40-2 H L
M50-2 L	M50-2 H L
M60-2 L	M60-2 H L

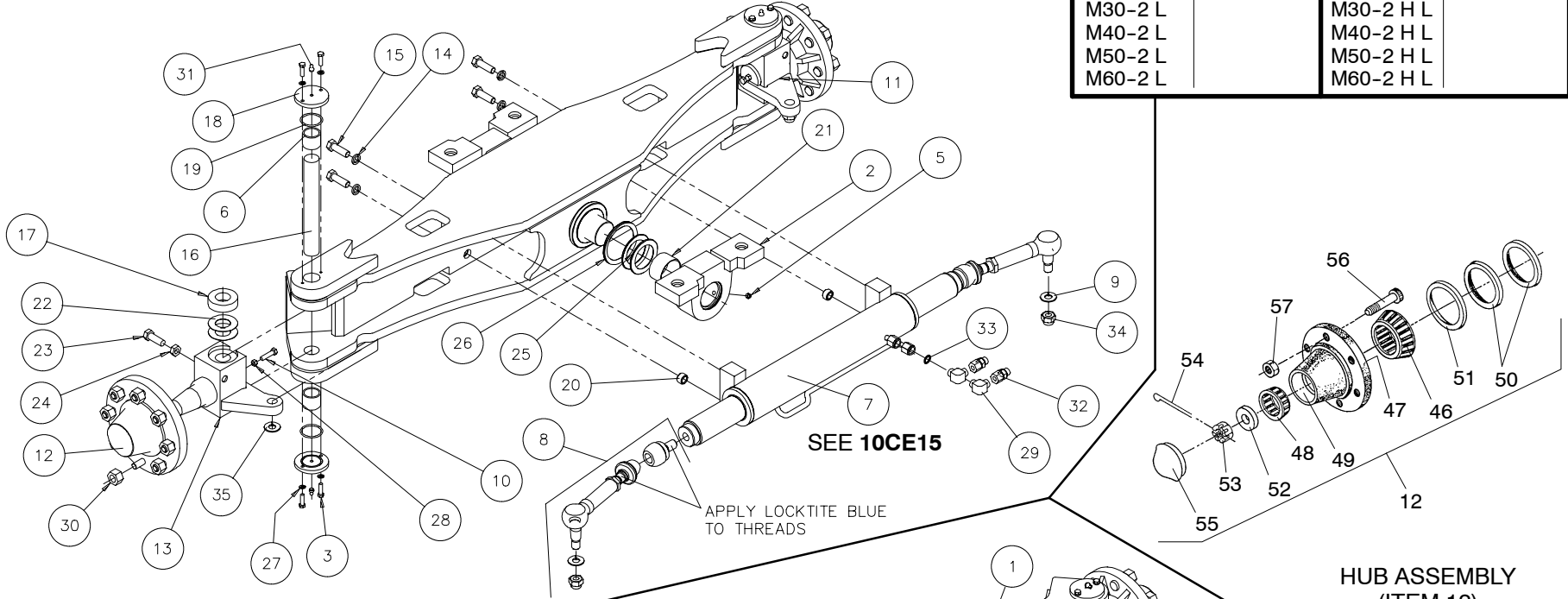

1ST MOUNTING
 S/N: 750471 & BELOW
 STEER AXLE ASSEMBLY
 803284 (OBSOLETE)

2ND MOUNTING
 S/N: 750472 & ABOVE
 STEER AXLE ASSEMBLY
 803671 (REPLACES 803284)

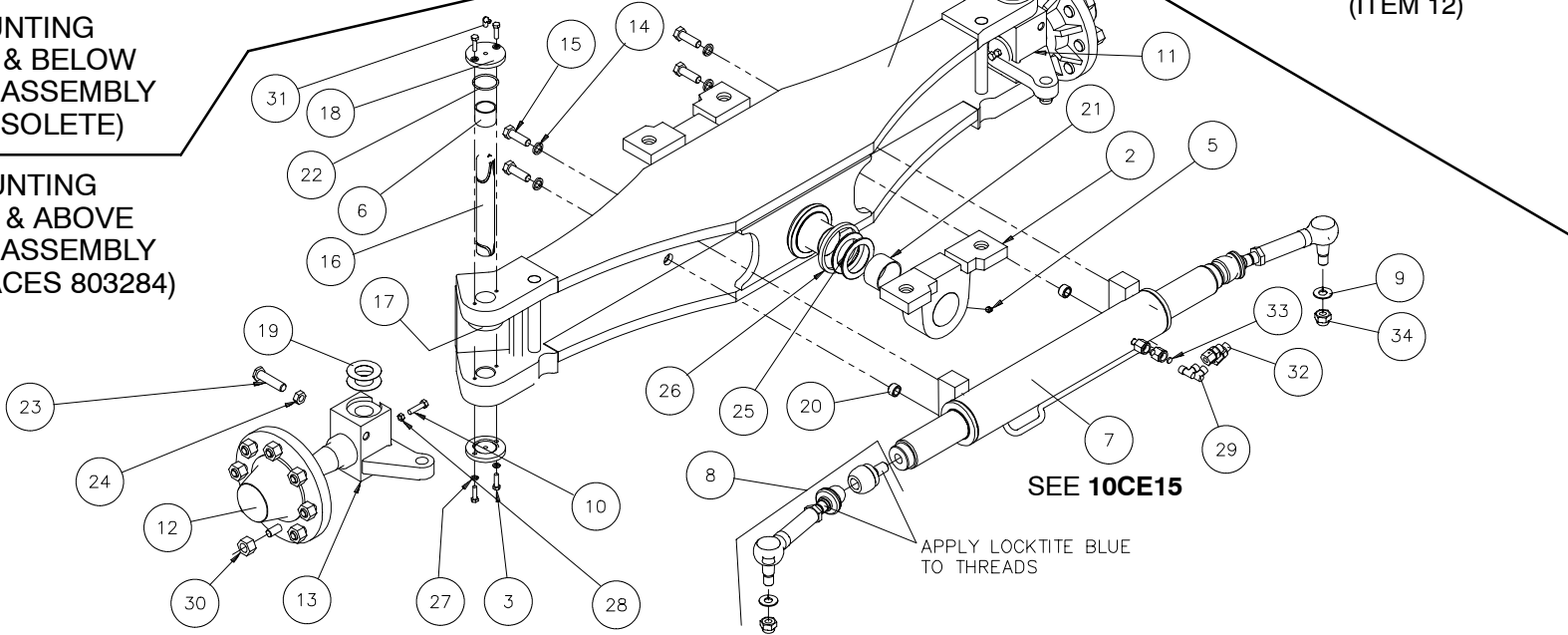

1	STEER AXLE, 2WD		QUANTITY / MODEL												7 AA 11			
			M30-2	M40-2	M50-2	M60-2	M30-2 H	M40-2 H	M50-2 H	M60-2 H	M30-2 L	M40-2 L	M50-2 L	M60-2 L	M30-2 H L	M40-2 H L	M50-2 H L	M60-2 H L
ITEM	PART NO.	DESCRIPTION	M30-2	M40-2	M50-2	M60-2	M30-2 H	M40-2 H	M50-2 H	M60-2 H	M30-2 L	M40-2 L	M50-2 L	M60-2 L	M30-2 H L	M40-2 H L	M50-2 H L	M60-2 H L
1*	803671	Steer axle assembly, complete (replaces 803284)	1	1	1	1	1	1	1	1	1	1	1	1	1	1	1	1
	803668	Steer axle weldment, 2WD	1	1	1	1	1	1	1	1	1	1	1	1	1	1	1	1
2	206698	Bushing housing	2	2	2	2	2	2	2	2	2	2	2	2	2	2	2	2
3	63754	Bolt	8	8	8	8	8	8	8	8	8	8	8	8	8	8	8	8
5	T51534	Grease fitting	2	2	2	2	2	2	2	2	2	2	2	2	2	2	2	2
6	426041	Bushing	4	4	4	4	4	4	4	4	4	4	4	4	4	4	4	4
7	200316	Steering cylinder assembly	1	1	1	1	1	1	1	1	1	1	1	1	1	1	1	1
8	229433	Rod assembly coupling	2	2	2	2	2	2	2	2	2	2	2	2	2	2	2	2
9	61683	Washer, flat	2	2	2	2	2	2	2	2	2	2	2	2	2	2	2	2
10	K302264	Screw	2	2	2	2	2	2	2	2	2	2	2	2	2	2	2	2
11	803920	Spindle arm, LH	1	1	1	1	1	1	1	1	1	1	1	1	1	1	1	1
12	421318	Hub assembly	2	2	2	2	2	2	2	2	2	2	2	2	2	2	2	2
13	803922	Spindle arm, RH	1	1	1	1	1	1	1	1	1	1	1	1	1	1	1	1
14	42322	Washer, lock	4	4	4	4	4	4	4	4	4	4	4	4	4	4	4	4
15	61308	Bolt	4	4	4	4	4	4	4	4	4	4	4	4	4	4	4	4
16A	802209	King pin (S/N: 750471 & below)	2	2	2	2	2	2	2	2	2	2	2	2	2	2	2	2
16B	426042	King pin (S/N: 750472 & above)	2	2	2	2	2	2	2	2	2	2	2	2	2	2	2	2
17	421520	Bearing, thrust	2	2	2	2	2	2	2	2	2	2	2	2	2	2	2	2
18	425674	Cover, king pin	4	4	4	4	4	4	4	4	4	4	4	4	4	4	4	4
19	K134	O-ring	4	4	4	4	4	4	4	4	4	4	4	4	4	4	4	4
20	200317	Centering bushing	2	2	2	2	2	2	2	2	2	2	2	2	2	2	2	2
21	203515	Bushing	2	2	2	2	2	2	2	2	2	2	2	2	2	2	2	2
22	426131	Shim	A/R	A/R	A/R	A/R	A/R	A/R	A/R	A/R	A/R	A/R	A/R	A/R	A/R	A/R	A/R	A/R
23	203524	Stop bolt	2	2	2	2	2	2	2	2	2	2	2	2	2	2	2	2
24	58574	Nut	2	2	2	2	2	2	2	2	2	2	2	2	2	2	2	2
25	203516	Washer, spacer (3mm - .118 in.)	A/R	A/R	A/R	A/R	A/R	A/R	A/R	A/R	A/R	A/R	A/R	A/R	A/R	A/R	A/R	A/R
25	203517	Washer, spacer (3.5mm - .138 in.)	A/R	A/R	A/R	A/R	A/R	A/R	A/R	A/R	A/R	A/R	A/R	A/R	A/R	A/R	A/R	A/R
25	203518	Washer, spacer (4mm - .157 in.)	A/R	A/R	A/R	A/R	A/R	A/R	A/R	A/R	A/R	A/R	A/R	A/R	A/R	A/R	A/R	A/R

2	STEER AXLE, 2WD		QUANTITY / MODEL												7 AA 11			
			M30-4	M40-4	M50-4	M60-4	M30-4 H	M40-4 H	M50-4 H	M60-4 H	M30-4 L	M40-4 L	M50-4 L	M60-4 L	M30-4 H L	M40-4 H L	M50-4 H L	M60-4 H L
ITEM	PART NO.	DESCRIPTION	M30-2	M40-2	M50-2	M60-2	M30-2 H	M40-2 H	M50-2 H	M60-2 H	M30-2 L	M40-2 L	M50-2 L	M60-2 L	M30-2 H L	M40-2 H L	M50-2 H L	M60-2 H L
26	803576	Seal	2	2	2	2	2	2	2	2	2	2	2	2	2	2	2	2
27	42325	Washer, lock	8	8	8	8	8	8	8	8	8	8	8	8	8	8	8	8
28	K33799	Nut	2	2	2	2	2	2	2	2	2	2	2	2	2	2	2	2
29	89179	Connector	2	2	2	2	2	2	2	2	2	2	2	2	2	2	2	2
30	421116	Nut, steer lug	16	16	16	16	16	16	16	16	16	16	16	16	16	16	16	16
31A	K87901	Grease fitting, extra short	4	4	4	4	4	4	4	4	4	4	4	4	4	4	4	4
31B	K87914	Grease fitting, 90°	4	4	4	4	4	4	4	4	4	4	4	4	4	4	4	4
32	803285	Adapter, swivel	2	2	2	2	2	2	2	2	2	2	2	2	2	2	2	2
33	169437	Seal	2	2	2	2	2	2	2	2	2	2	2	2	2	2	2	2
34	86832	Nut, lock	2	2	2	2	2	2	2	2	2	2	2	2	2	2	2	2
35**	R24165-58	Washer	2	2	2	2	2	2	2	2	2	2	2	2	2	2	2	2
46	421305	Bearing, inner	1	1	1	1	1	1	1	1	1	1	1	1	1	1	1	1
47	421313	Inner Bearing Race	1	1	1	1	1	1	1	1	1	1	1	1	1	1	1	1
48	421306	Bearing, Outer	1	1	1	1	1	1	1	1	1	1	1	1	1	1	1	1
49	421314	Outer Bearing Race	1	1	1	1	1	1	1	1	1	1	1	1	1	1	1	1
50	421538	Washer, Felt	4	4	4	4	4	4	4	4	4	4	4	4	4	4	4	4
51	421307	Seal, Grease	1	1	1	1	1	1	1	1	1	1	1	1	1	1	1	1
52	421309	Washer, Spindle	6	6	6	6	6	6	6	6	6	6	6	6	6	6	6	6
53	421311	Pin, Cotter	1	1	1	1	1	1	1	1	1	1	1	1	1	1	1	1
54	421310	Nut, Slotted	1	1	1	1	1	1	1	1	1	1	1	1	1	1	1	1
55	421304	Cap, Grease	1	1	1	1	1	1	1	1	1	1	1	1	1	1	1	1
56	421315	Bolt, Lug	8	8	8	8	8	8	8	8	8	8	8	8	8	8	8	8
57	421116	Nut, Lug	8	8	8	8	8	8	8	8	8	8	8	8	8	8	8	8

* S/N: 750471 & below also requires:
Item 2 - Bushing housing (2) and Item 16 - King pin (2).

** Early models only; with 1 1/8 in. thick spindle arm plate

7 AB 10

STEERING AXLE AND DRIVESHAFT INSTALLATION, 4WD

M30-4
M40-4
M50-4
M60-4

M30-4 H
M40-4 H
M50-4 H
M60-4 H

M30-4 L
M40-4 L
M50-4 L
M60-4 L

M30-4 H L
M40-4 H L
M50-4 H L
M60-4 H L

NOTE:
APPLY LOCTITE 242 (BLUE)
TO THE THREADS
OF ALL BOLTS DURING INSTALLATION.

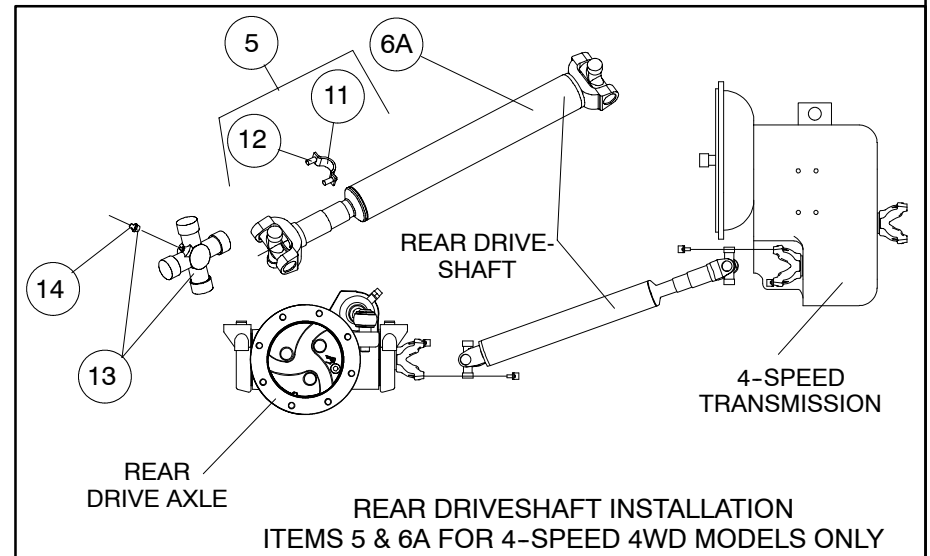
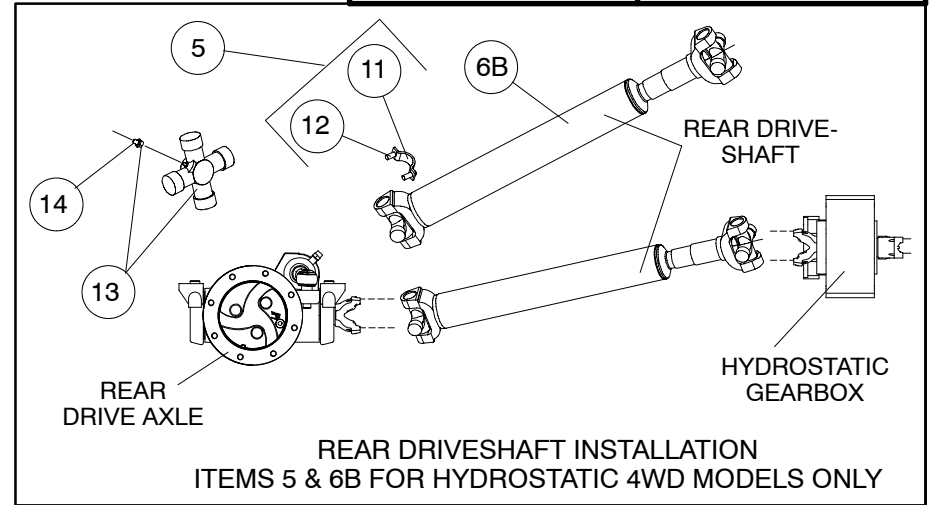
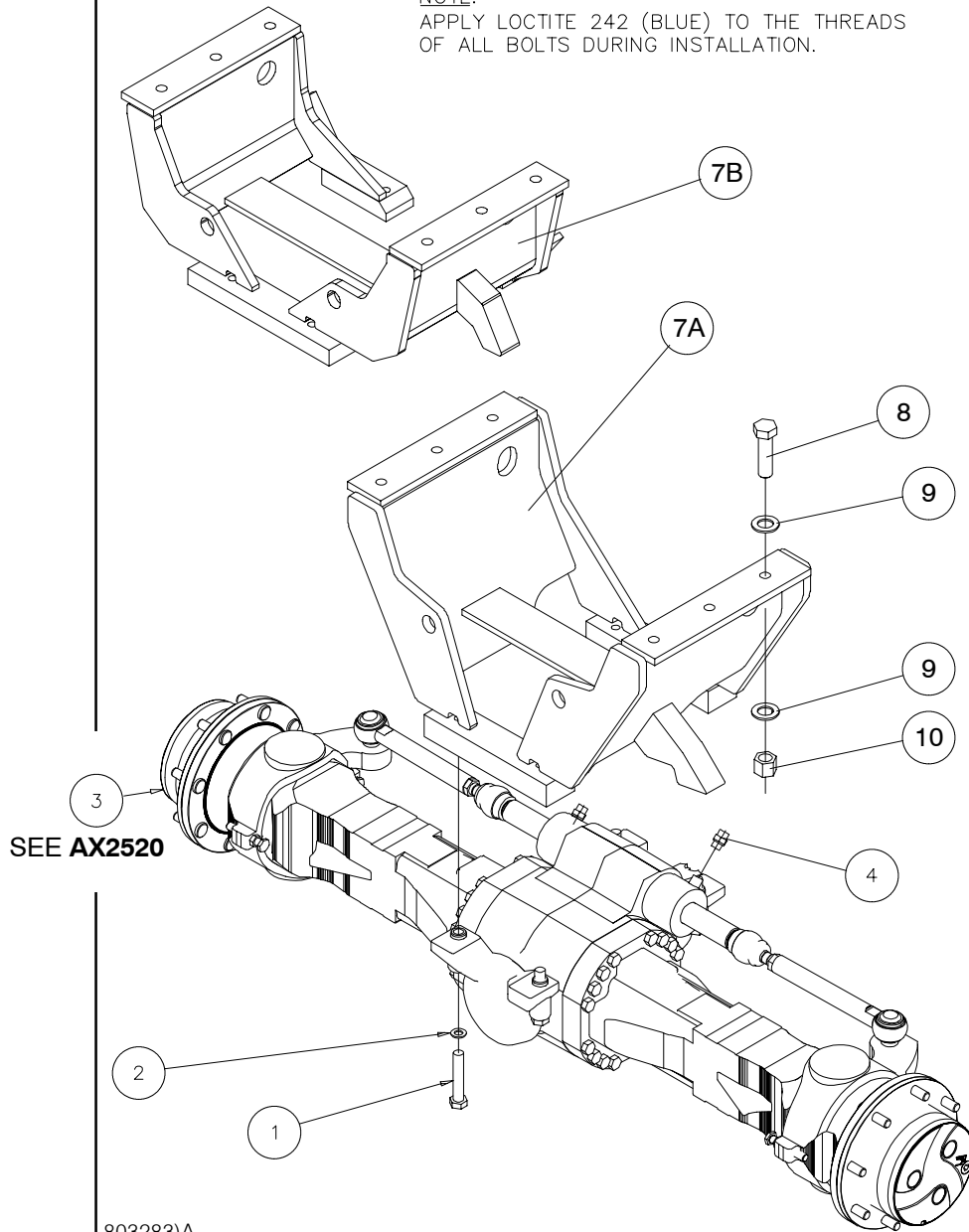

1	STEERING AXLE AND DRIVESHAFT INSTALLATION, 4WD		QUANTITY / MODEL											7 AB 10				
			M30-4	M40-4	M50-4	M60-4	M30-4 H	M40-4 H	M50-4 H	M60-4 H	M30-4 L	M40-4 L	M50-4 L	M60-4 L	M30-4 H L	M40-4 H L	M50-4 H L	M60-4 H L
ITEM	PART NO.	DESCRIPTION																
1	58633	Bolt	4	4	4	4	4	4	4	4	4	4	4	4	4	4	4	4
2	61683	Washer, flat	4	4	4	4	4	4	4	4	4	4	4	4	4	4	4	4
3A	238216	Steer axle assembly (4-SPEED MODELS ONLY)	1	1	1	1					1	1	1	1				
3B	801988	Steer axle assembly (HYDROSTATIC MODELS ONLY)					1	1	1	1					1	1	1	1
4	803282	Connector	2	2	2	2	2	2	2	2	2	2	2	2	2	2	2	2
5	425330	Strap and bolt kit	2	2	2	2	2	2	2	2	2	2	2	2	2	2	2	2
6A	802048	Drive shaft, rear (4-SPEED MODELS ONLY)	1	1	1	1					1	1	1	1				
6B	802049	Drive shaft, rear (HYDROSTATIC MODELS ONLY)					1	1	1	1					1	1	1	1
7A	801931	Axle hanger, (100 & 81 IN. CAB ONLY)	1	1	1	1	1	1	1	1	1	1	1	1	1	1	1	1
7B	801930	Axle hanger, (77 IN. CAB ONLY)	1	1	1	1	1	1	1	1	1	1	1	1	1	1	1	1
8	426688	Bolt	6	6	6	6	6	6	6	6	6	6	6	6	6	6	6	6
9	426650	Washer, flat	12	12	12	12	12	12	12	12	12	12	12	12	12	12	12	12
10	R32	Nut	6	6	6	6	6	6	6	6	6	6	6	6	6	6	6	6
11	109751	Strap	A/R	A/R	A/R	A/R	A/R	A/R	A/R	A/R	A/R	A/R	A/R	A/R	A/R	A/R	A/R	A/R
12	109752	Bolt	A/R	A/R	A/R	A/R	A/R	A/R	A/R	A/R	A/R	A/R	A/R	A/R	A/R	A/R	A/R	A/R
13	424647	U-joint	A/R	A/R	A/R	A/R	A/R	A/R	A/R	A/R	A/R	A/R	A/R	A/R	A/R	A/R	A/R	A/R
14	162809	Zerk, grease fitting	A/R	A/R	A/R	A/R	A/R	A/R	A/R	A/R	A/R	A/R	A/R	A/R	A/R	A/R	A/R	A/R

8 AA 10

CAB ASSEMBLY, 100 IN. FULLY ENCLOSED

M30-2	M30-4	M30-2 H	M30-4 H
M40-2	M40-4	M40-2 H	M40-4 H
M50-2	M50-4	M50-2 H	M50-4 H
M60-2	M60-4	M60-2 H	M60-4 H
M30-2 L	M30-4 L	M30-2 H L	M30-4 H L
M40-2 L	M40-4 L	M40-2 H L	M40-4 H L
M50-2 L	M50-4 L	M50-2 H L	M50-4 H L
M60-2 L	M60-4 L	M60-2 H L	M60-4 H L

CAB ASSEMBLY INCLUDES WIRING FOR CAB OPTIONS (BEACON, WORK LIGHTS, ETC.)

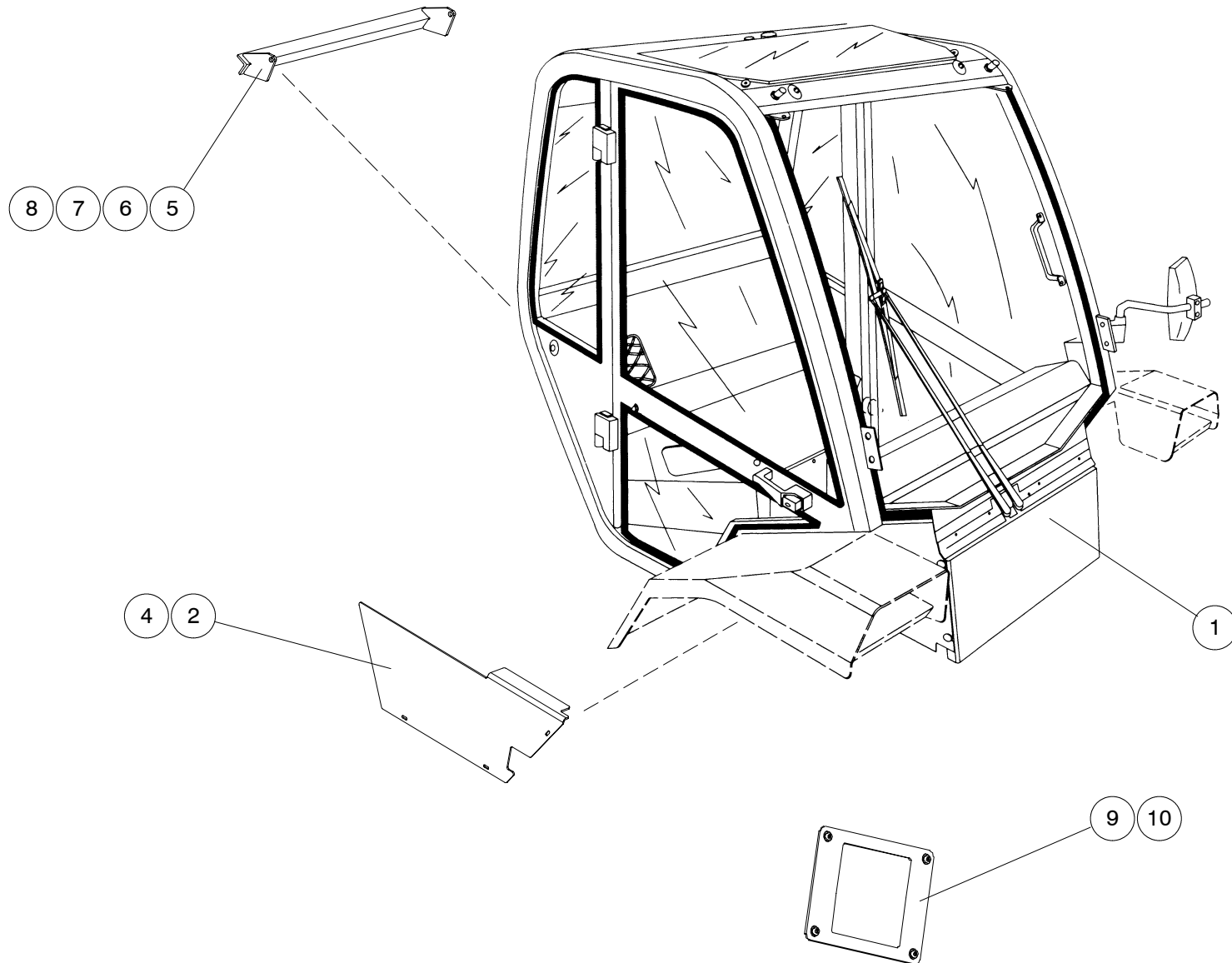

1	CAB ASSEMBLY, 100 IN. FULLY ENCLOSED												8 AA 10						
	ITEM	PART NO.	DESCRIPTION	M30-2	M40-2	M50-2	M60-2	M30-2 H	M40-2 H	M50-2 H	M60-2 H	M30-2 L	M40-2 L	M50-2 L	M60-2 L	M30-2 H L	M40-2 H L	M50-2 H L	M60-2 H L
1A	238351	Cab assembly, fully enclosed (DOES NOT include the front fenders or Items 2 thru 10) S/N: 750185 & below, except 750168 & 750182	1	1	1	1	1	1	1	1	1	1	1	1	1	1	1	1	1
1B	245772	Cab assembly, fully enclosed (DOES NOT include the front fenders or Items 2 thru 10) S/N: 750168, 750182 & above, except 750185	1	1	1	1	1	1	1	1	1	1	1	1	1	1	1	1	1
2	802805	Cover, cab RH	1	1	1	1	1	1	1	1	1	1	1	1	1	1	1	1	1
3	802804	Cover, cab LH (not shown)	1	1	1	1	1	1	1	1	1	1	1	1	1	1	1	1	1
4	189172	Screw	6	6	6	6	6	6	6	6	6	6	6	6	6	6	6	6	6
5	802658	Cab angle assembly	1	1	1	1	1	1	1	1	1	1	1	1	1	1	1	1	1
6	29437	Washer, flat	4	4	4	4	4	4	4	4	4	4	4	4	4	4	4	4	4
7	56354	Nut	2	2	2	2	2	2	2	2	2	2	2	2	2	2	2	2	2
8	168354	Bolt	2	2	2	2	2	2	2	2	2	2	2	2	2	2	2	2	2
9	216355	Bracket, guage	1	1	1	1	1	1	1	1	1	1	1	1	1	1	1	1	1
10	79533	Screw	4	4	4	4	4	4	4	4	4	4	4	4	4	4	4	4	4

8 AA 11

CAB DETAILS 1, 100 IN. FULLY ENCLOSED

M30-2	M30-4	M30-2 H	M30-4 H
M40-2	M40-4	M40-2 H	M40-4 H
M50-2	M50-4	M50-2 H	M50-4 H
M60-2	M60-4	M60-2 H	M60-4 H
M30-2 L	M30-4 L	M30-2 H L	M30-4 H L
M40-2 L	M40-4 L	M40-2 H L	M40-4 H L
M50-2 L	M50-4 L	M50-2 H L	M50-4 H L
M60-2 L	M60-4 L	M60-2 H L	M60-4 H L

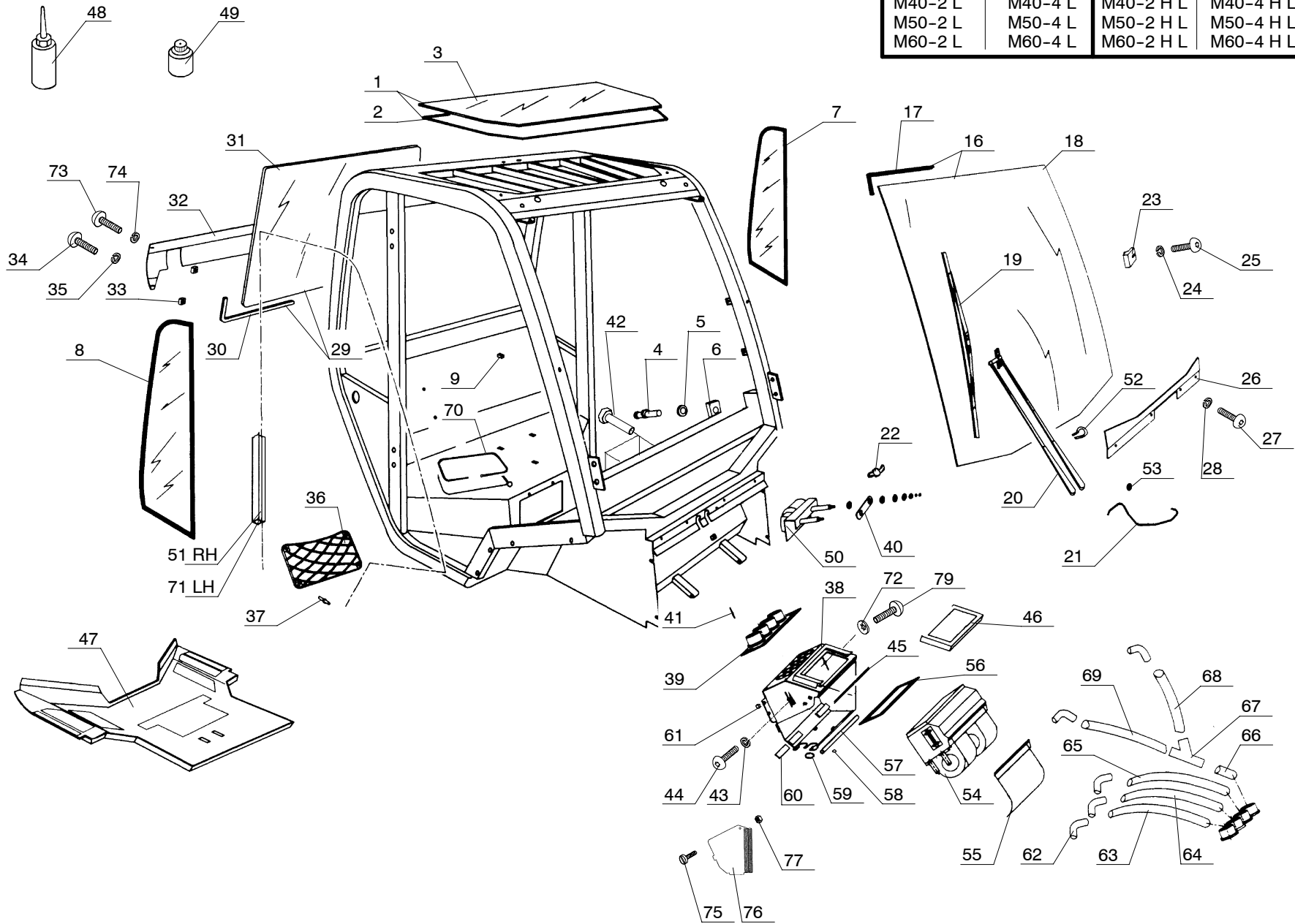

1	CAB DETAILS 1, 100 IN. FULLY ENCLOSED		QUANTITY / MODEL											8 AA 11				
			M30-4	M40-4	M50-4	M60-4	M30-4 H	M40-4 H	M50-4 H	M60-4 H	M30-4 L	M40-4 L	M50-4 L	M60-4 L	M30-4 H L	M40-4 H L	M50-4 H L	M60-4 H L
ITEM	PART NO.	DESCRIPTION	M30-2	M40-2	M50-2	M60-2	M30-2 H	M40-2 H	M50-2 H	M60-2 H	M30-2 L	M40-2 L	M50-2 L	M60-2 L	M30-2 H L	M40-2 H L	M50-2 H L	M60-2 H L
1	552426	Weatherstrip	1	1	1	1	1	1	1	1	1	1	1	1	1	1	1	1
2	182038	Seal	1	1	1	1	1	1	1	1	1	1	1	1	1	1	1	1
3	206271	Roof glass	1	1	1	1	1	1	1	1	1	1	1	1	1	1	1	1
4	182179	Fastener	2	2	2	2	2	2	2	2	2	2	2	2	2	2	2	2
5	182180	Washer	2	2	2	2	2	2	2	2	2	2	2	2	2	2	2	2
6	182181	Fastening plate	2	2	2	2	2	2	2	2	2	2	2	2	2	2	2	2
7	561093	Side glass, LH	1	1	1	1	1	1	1	1	1	1	1	1	1	1	1	1
8	561092	Side glass, RH	1	1	1	1	1	1	1	1	1	1	1	1	1	1	1	1
9	551882	Nut	4	4	4	4	4	4	4	4	4	4	4	4	4	4	4	4
16	561515	Front windshield w/seal	1	1	1	1	1	1	1	1	1	1	1	1	1	1	1	1
17	189752	Weatherstrip	1	1	1	1	1	1	1	1	1	1	1	1	1	1	1	1
18	561086	Front windshield	1	1	1	1	1	1	1	1	1	1	1	1	1	1	1	1
19	198290	Wiper blade	1	1	1	1	1	1	1	1	1	1	1	1	1	1	1	1
20	561518	Blade holder	1	1	1	1	1	1	1	1	1	1	1	1	1	1	1	1
21	199956	Hose	1	1	1	1	1	1	1	1	1	1	1	1	1	1	1	1
22	199955	Connection	1	1	1	1	1	1	1	1	1	1	1	1	1	1	1	1
23	552670	Fastening lug	2	2	2	2	2	2	2	2	2	2	2	2	2	2	2	2
24	174132	Washer	2	2	2	2	2	2	2	2	2	2	2	2	2	2	2	2
25	205275	Screw	2	2	2	2	2	2	2	2	2	2	2	2	2	2	2	2
26	561519	Fastening plate	1	1	1	1	1	1	1	1	1	1	1	1	1	1	1	1
27	183396	Screw	4	4	4	4	4	4	4	4	4	4	4	4	4	4	4	4
28	194673	Washer	4	4	4	4	4	4	4	4	4	4	4	4	4	4	4	4
29	561520	Weatherstrip	1	1	1	1	1	1	1	1	1	1	1	1	1	1	1	1
30	182101	Weatherstrip	1	1	1	1	1	1	1	1	1	1	1	1	1	1	1	1

8 AA 12

CAB DETAILS 2, 100 IN. FULLY ENCLOSED

M30-2	M30-4	M30-2 H	M30-4 H
M40-2	M40-4	M40-2 H	M40-4 H
M50-2	M50-4	M50-2 H	M50-4 H
M60-2	M60-4	M60-2 H	M60-4 H
M30-2 L	M30-4 L	M30-2 H L	M30-4 H L
M40-2 L	M40-4 L	M40-2 H L	M40-4 H L
M50-2 L	M50-4 L	M50-2 H L	M50-4 H L
M60-2 L	M60-4 L	M60-2 H L	M60-4 H L

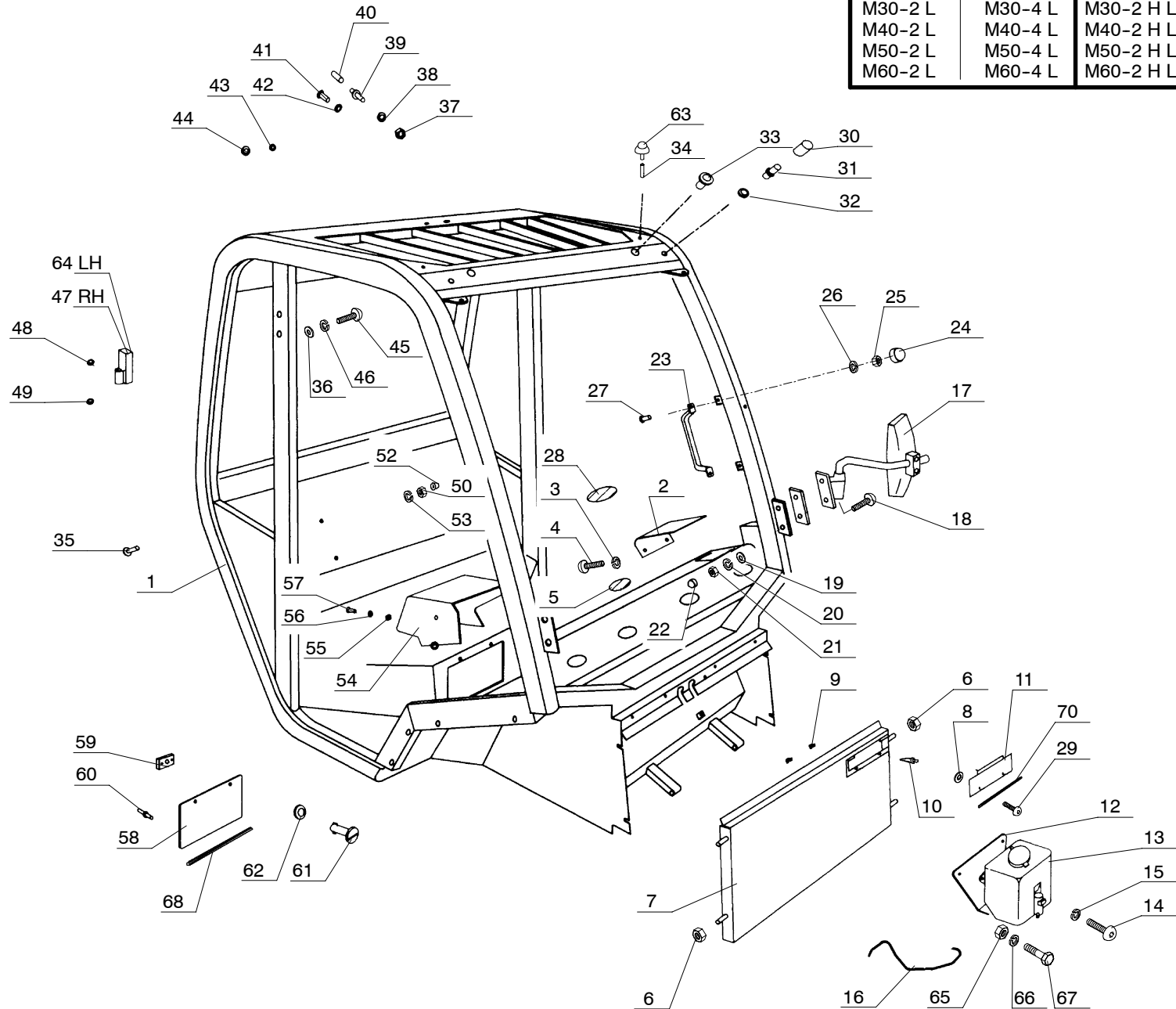

1	CAB DETAILS 2, 100 IN. FULLY ENCLOSED												8 AA 12						
	ITEM	PART NO.	DESCRIPTION	M30-2	M40-2	M50-2	M60-2	M30-2 H	M40-2 H	M50-2 H	M60-2 H	M30-2 L	M40-2 L	M50-2 L	M60-2 L	M30-2 H L	M40-2 H L	M50-2 H L	M60-2 H L
1	603844	Frame work	1	1	1	1	1	1	1	1	1	1	1	1	1	1	1	1	1
2	561524	Fastening plate	1	1	1	1	1	1	1	1	1	1	1	1	1	1	1	1	1
3	194673	Washer	2	2	2	2	2	2	2	2	2	2	2	2	2	2	2	2	2
4	183396	Screw	2	2	2	2	2	2	2	2	2	2	2	2	2	2	2	2	2
5	561527	Air nozzle	4	4	4	4	4	4	4	4	4	4	4	4	4	4	4	4	4
6	54242	Nut	4	4	4	4	4	4	4	4	4	4	4	4	4	4	4	4	4
7	562196	Front fastening plate	1	1	1	1	1	1	1	1	1	1	1	1	1	1	1	1	1
8	562197	Washer	2	2	2	2	2	2	2	2	2	2	2	2	2	2	2	2	2
9	562198	Locking casing	2	2	2	2	2	2	2	2	2	2	2	2	2	2	2	2	2
10	174677	Rivet	4	4	4	4	4	4	4	4	4	4	4	4	4	4	4	4	4
11	562199	Fastening plate	1	1	1	1	1	1	1	1	1	1	1	1	1	1	1	1	1
12	201008	Bracket	1	1	1	1	1	1	1	1	1	1	1	1	1	1	1	1	1
13	190776	Windshield washer tank	1	1	1	1	1	1	1	1	1	1	1	1	1	1	1	1	1
14	79533	Screw	2	2	2	2	2	2	2	2	2	2	2	2	2	2	2	2	2
15	29483	Washer	2	2	2	2	2	2	2	2	2	2	2	2	2	2	2	2	2
16	561526	Hose	1	1	1	1	1	1	1	1	1	1	1	1	1	1	1	1	1
17A	561426	Rear view mirror, complete LH	1	1	1	1	1	1	1	1	1	1	1	1	1	1	1	1	1
17B	803417	Rear view mirror, complete RH (572281ACC)	1	1	1	1	1	1	1	1	1	1	1	1	1	1	1	1	1
18	29441	Screw	2	2	2	2	2	2	2	2	2	2	2	2	2	2	2	2	2
19	29469	Washer	2	2	2	2	2	2	2	2	2	2	2	2	2	2	2	2	2
20	42316	Washer	2	2	2	2	2	2	2	2	2	2	2	2	2	2	2	2	2
21	25714	Nut	2	2	2	2	2	2	2	2	2	2	2	2	2	2	2	2	2
22	55404	Cap	2	2	2	2	2	2	2	2	2	2	2	2	2	2	2	2	2
23	195535	Handle	2	2	2	2	2	2	2	2	2	2	2	2	2	2	2	2	2
24	55404	Cap	4	4	4	4	4	4	4	4	4	4	4	4	4	4	4	4	4
25	25714	Nut	4	4	4	4	4	4	4	4	4	4	4	4	4	4	4	4	4
26	29469	Washer	4	4	4	4	4	4	4	4	4	4	4	4	4	4	4	4	4
27	46668	Screw	4	4	4	4	4	4	4	4	4	4	4	4	4	4	4	4	4

8 AA 13

CAB DETAILS 3, 100 IN. FULLY ENCLOSED

M30-2	M30-4	M30-2 H	M30-4 H
M40-2	M40-4	M40-2 H	M40-4 H
M50-2	M50-4	M50-2 H	M50-4 H
M60-2	M60-4	M60-2 H	M60-4 H
M30-2 L	M30-4 L	M30-2 H L	M30-4 H L
M40-2 L	M40-4 L	M40-2 H L	M40-4 H L
M50-2 L	M50-4 L	M50-2 H L	M50-4 H L
M60-2 L	M60-4 L	M60-2 H L	M60-4 H L

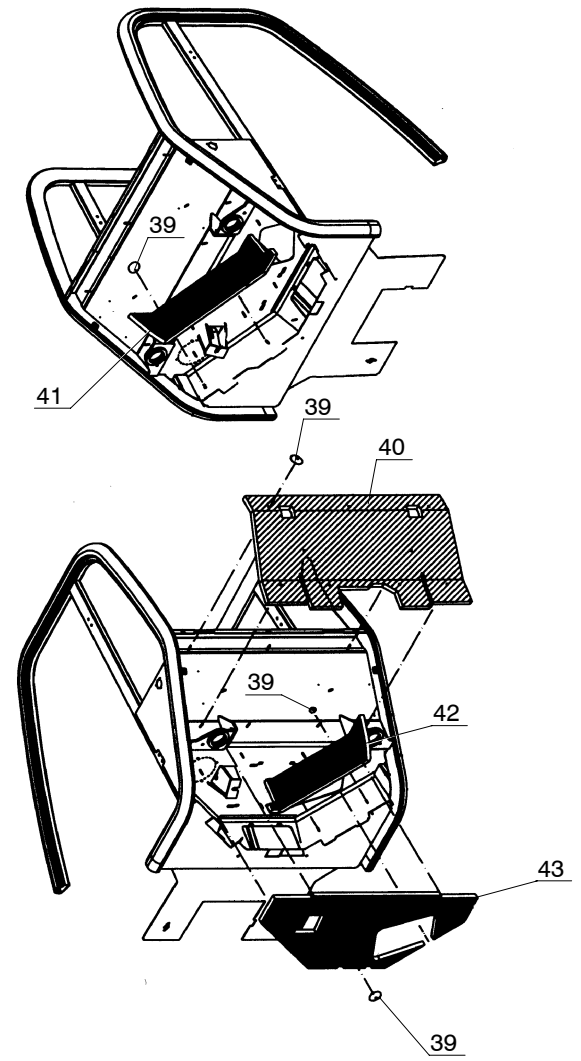
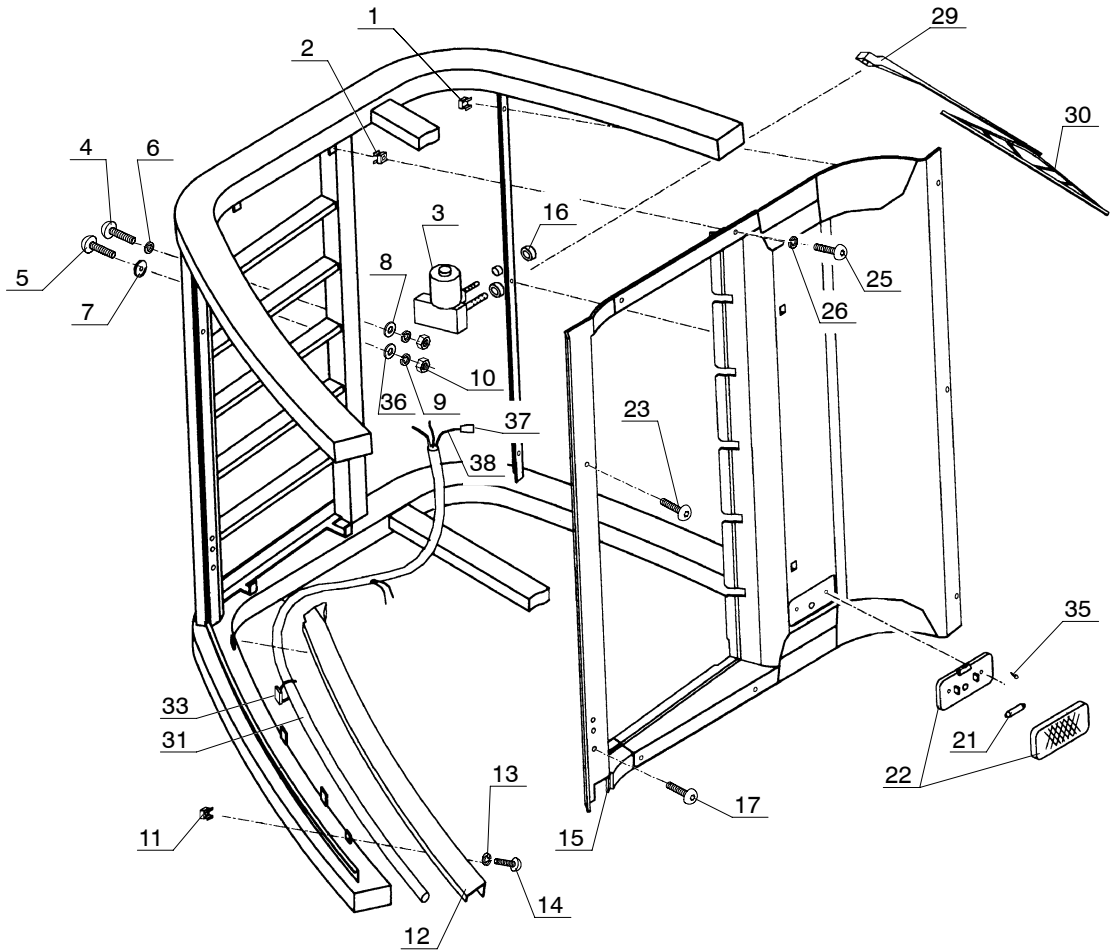

1	CAB DETAILS 3, 100 IN. FULLY ENCLOSED		QUANTITY / MODEL												8 AA 13			
			M30-4	M40-4	M50-4	M60-4	M30-4 H	M40-4 H	M50-4 H	M60-4 H	M30-4 L	M40-4 L	M50-4 L	M60-4 L	M30-4 H L	M40-4 H L	M50-4 H L	M60-4 H L
ITEM	PART NO.	DESCRIPTION	M30-2	M40-2	M50-2	M60-2	M30-2 H	M40-2 H	M50-2 H	M60-2 H	M30-2 L	M40-2 L	M50-2 L	M60-2 L	M30-2 H L	M40-2 H L	M50-2 H L	M60-2 H L
1	551582	Nut	3	3	3	3	3	3	3	3	3	3	3	3	3	3	3	3
2	551582	Nut	4	4	4	4	4	4	4	4	4	4	4	4	4	4	4	4
3	552760	Windshield wiper motor	1	1	1	1	1	1	1	1	1	1	1	1	1	1	1	1
4	202144	Screw	1	1	1	1	1	1	1	1	1	1	1	1	1	1	1	1
5	42412	Screw	1	1	1	1	1	1	1	1	1	1	1	1	1	1	1	1
6	194661	Washer	1	1	1	1	1	1	1	1	1	1	1	1	1	1	1	1
7	551560	Washer	1	1	1	1	1	1	1	1	1	1	1	1	1	1	1	1
8	61674	Washer	2	2	2	2	2	2	2	2	2	2	2	2	2	2	2	2
9	42325	Washer	2	2	2	2	2	2	2	2	2	2	2	2	2	2	2	2
10	58528	Nut	2	2	2	2	2	2	2	2	2	2	2	2	2	2	2	2
11	551582	Nut	2	2	2	2	2	2	2	2	2	2	2	2	2	2	2	2
12	561528	Drain trough	1	1	1	1	1	1	1	1	1	1	1	1	1	1	1	1
13	551600	Washer	2	2	2	2	2	2	2	2	2	2	2	2	2	2	2	2
14	199976	Screw	2	2	2	2	2	2	2	2	2	2	2	2	2	2	2	2
15	561529	Roof fitting	1	1	1	1	1	1	1	1	1	1	1	1	1	1	1	1
16	166702	Cap	1	1	1	1	1	1	1	1	1	1	1	1	1	1	1	1
17	205275	Screw	2	2	2	2	2	2	2	2	2	2	2	2	2	2	2	2
21	61799	Bulb	1	1	1	1	1	1	1	1	1	1	1	1	1	1	1	1
22	54564	Roof lamp	1	1	1	1	1	1	1	1	1	1	1	1	1	1	1	1
23	194668	Screw	2	2	2	2	2	2	2	2	2	2	2	2	2	2	2	2
25	199976	Screw	7	7	7	7	7	7	7	7	7	7	7	7	7	7	7	7
26	551600	Washer	7	7	7	7	7	7	7	7	7	7	7	7	7	7	7	7
29	184526	Blade holder	1	1	1	1	1	1	1	1	1	1	1	1	1	1	1	1
30	54557	Brush	1	1	1	1	1	1	1	1	1	1	1	1	1	1	1	1

8 AA 14

CAB DETAILS 4, 100 IN. FULLY ENCLOSED

M30-2	M30-4	M30-2 H	M30-4 H
M40-2	M40-4	M40-2 H	M40-4 H
M50-2	M50-4	M50-2 H	M50-4 H
M60-2	M60-4	M60-2 H	M60-4 H
M30-2 L	M30-4 L	M30-2 H L	M30-4 H L
M40-2 L	M40-4 L	M40-2 H L	M40-4 H L
M50-2 L	M50-4 L	M50-2 H L	M50-4 H L
M60-2 L	M60-4 L	M60-2 H L	M60-4 H L

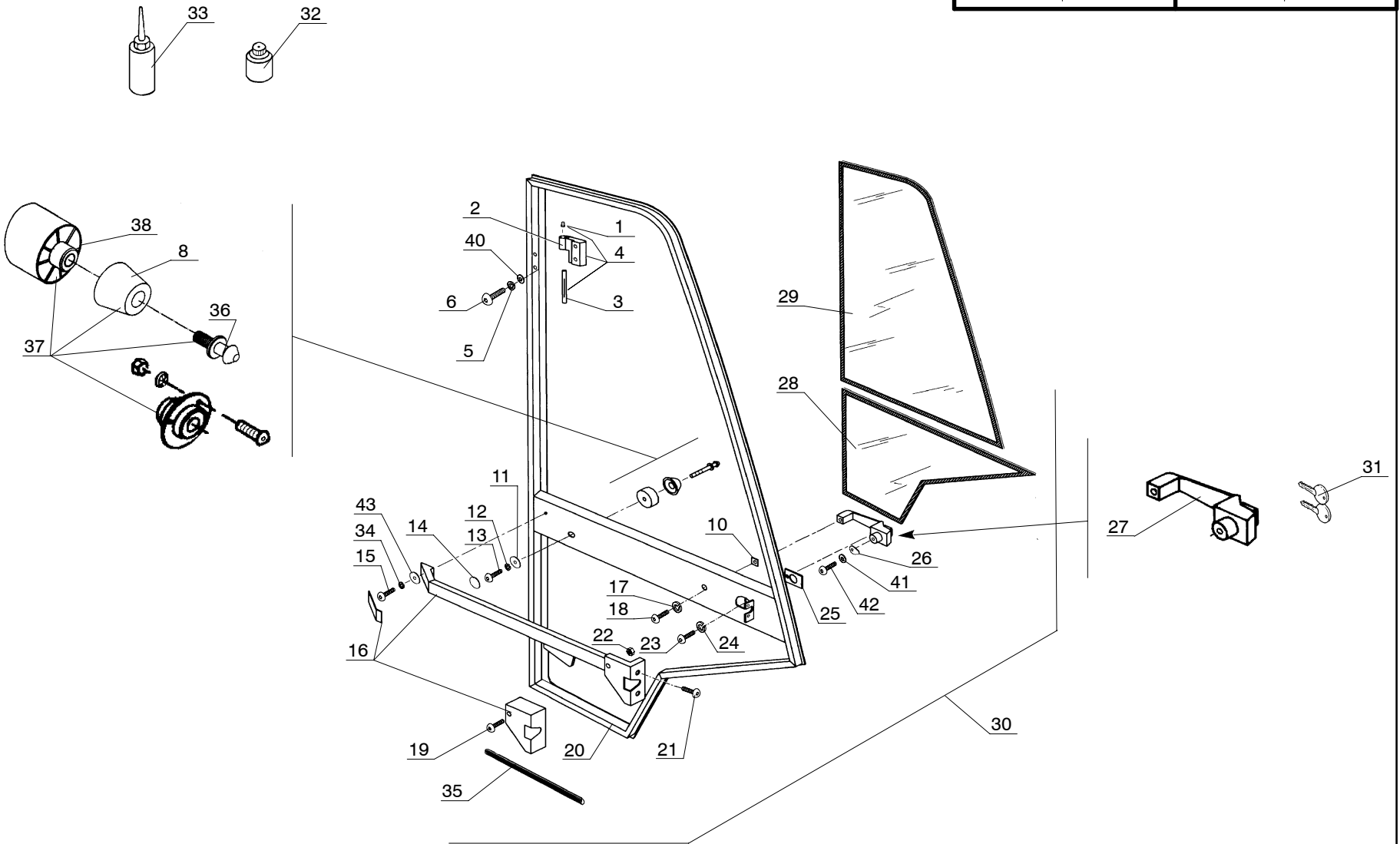

1	CAB DETAILS 4, 100 IN. FULLY ENCLOSED																	
	QUANTITY / MODEL												8 AA 14					
ITEM	PART NO.	DESCRIPTION	M30-2	M40-2	M50-2	M60-2	M30-2 H	M40-2 H	M50-2 H	M60-2 H	M30-2 L	M40-2 L	M50-2 L	M60-2 L	M30-2 H L	M40-2 H L	M50-2 H L	M60-2 H L
1	199961	Greaser	4	4	4	4	4	4	4	4	4	4	4	4	4	4	4	4
2	203452	Half hinge, stripped	2	2	2	2	2	2	2	2	2	2	2	2	2	2	2	2
3	199963	Axle	4	4	4	4	4	4	4	4	4	4	4	4	4	4	4	4
4	201931	Half hinge (includes Items 1, 2, 3)	2	2	2	2	2	2	2	2	2	2	2	2	2	2	2	2
5	42325	Washer	8	8	8	8	8	8	8	8	8	8	8	8	8	8	8	8
6	190734	Screw	8	8	8	8	8	8	8	8	8	8	8	8	8	8	8	8
8	550649	Door locking	2	2	2	2	2	2	2	2	2	2	2	2	2	2	2	2
10	564149	Gasket	2	2	2	2	2	2	2	2	2	2	2	2	2	2	2	2
11	61674	Washer	2	2	2	2	2	2	2	2	2	2	2	2	2	2	2	2
12	42325	Washer	2	2	2	2	2	2	2	2	2	2	2	2	2	2	2	2
13	202731	Screw	2	2	2	2	2	2	2	2	2	2	2	2	2	2	2	2
14	603210	Plug	2	2	2	2	2	2	2	2	2	2	2	2	2	2	2	2
15	196951	Screw	2	2	2	2	2	2	2	2	2	2	2	2	2	2	2	2
16	551869	Inner lock, LH	1	1	1	1	1	1	1	1	1	1	1	1	1	1	1	1
17	174132	Washer	2	2	2	2	2	2	2	2	2	2	2	2	2	2	2	2
18	183396	Screw	2	2	2	2	2	2	2	2	2	2	2	2	2	2	2	2
19	199978	Screw	2	2	2	2	2	2	2	2	2	2	2	2	2	2	2	2
20	600831	Door, stripped, LH	1	1	1	1	1	1	1	1	1	1	1	1	1	1	1	1
21	199978	Screw	4	4	4	4	4	4	4	4	4	4	4	4	4	4	4	4
22	162229	Nut	2	2	2	2	2	2	2	2	2	2	2	2	2	2	2	2
23	183396	Screw	4	4	4	4	4	4	4	4	4	4	4	4	4	4	4	4
24	174132	Washer	4	4	4	4	4	4	4	4	4	4	4	4	4	4	4	4
25	564148	Gasket	2	2	2	2	2	2	2	2	2	2	2	2	2	2	2	2
26	561535	Fastening plate	2	2	2	2	2	2	2	2	2	2	2	2	2	2	2	2
27	564147	Outer handle	2	2	2	2	2	2	2	2	2	2	2	2	2	2	2	2
28	561091	Lower door glass, stripped, LH	1	1	1	1	1	1	1	1	1	1	1	1	1	1	1	1

8 AA 15

CAB DETAILS 5, 100 IN. FULLY ENCLOSED

M30-2	M30-4	M30-2 H	M30-4 H
M40-2	M40-4	M40-2 H	M40-4 H
M50-2	M50-4	M50-2 H	M50-4 H
M60-2	M60-4	M60-2 H	M60-4 H
M30-2 L	M30-4 L	M30-2 H L	M30-4 H L
M40-2 L	M40-4 L	M40-2 H L	M40-4 H L
M50-2 L	M50-4 L	M50-2 H L	M50-4 H L
M60-2 L	M60-4 L	M60-2 H L	M60-4 H L

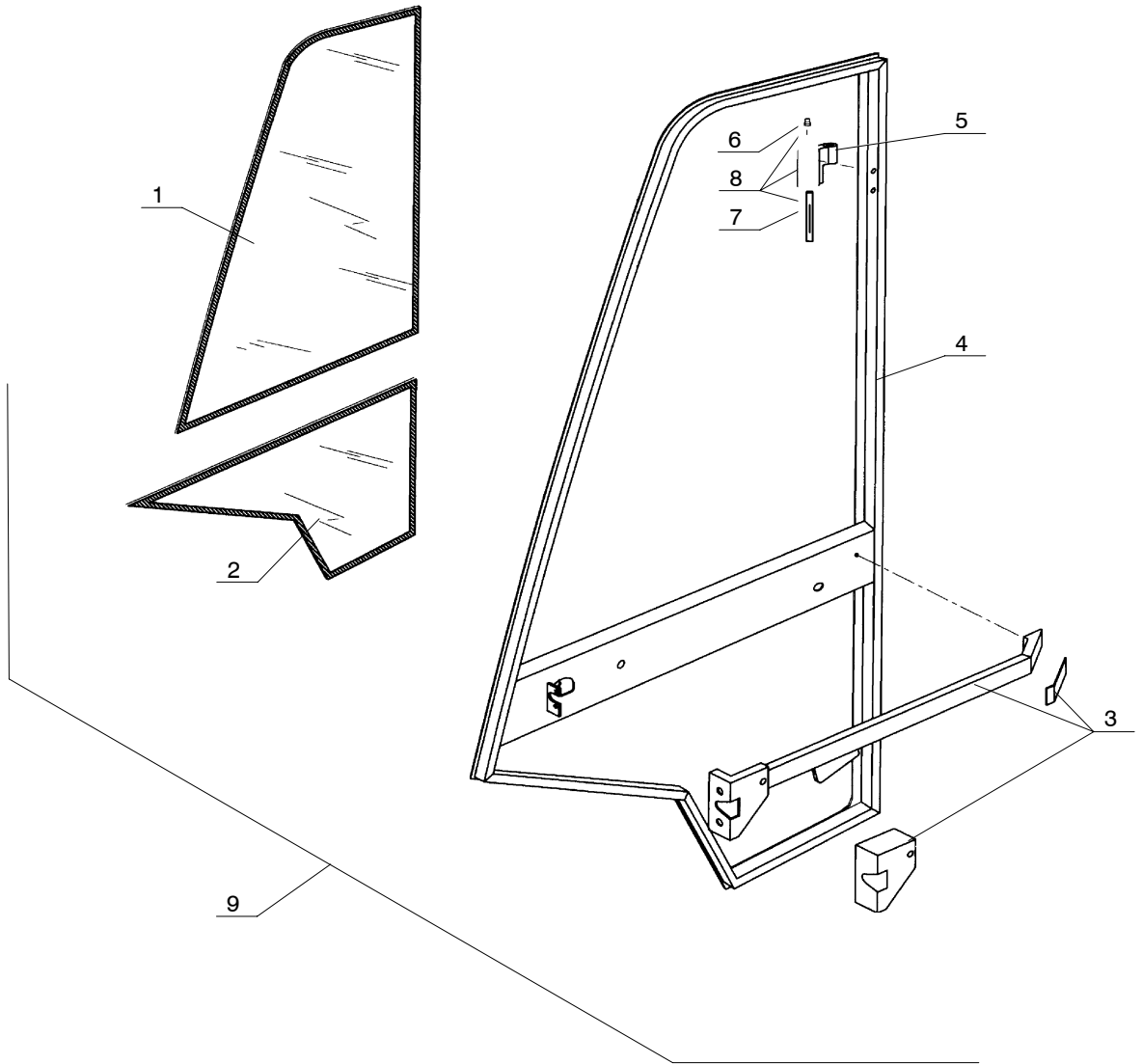

1	CAB DETAILS 5, 100 IN. FULLY ENCLOSED			QUANTITY / MODEL										8 AA 15				
				M30-4	M40-4	M50-4	M60-4	M30-4 H	M40-4 H	M50-4 H	M60-4 H	M30-4 L	M40-4 L	M50-4 L	M60-4 L	M30-4 H L	M40-4 H L	M50-4 H L
ITEM	PART NO.	DESCRIPTION	M30-2	M40-2	M50-2	M60-2	M30-2 H	M40-2 H	M50-2 H	M60-2 H	M30-2 L	M40-2 L	M50-2 L	M60-2 L	M30-2 H L	M40-2 H L	M50-2 H L	M60-2 H L
1	561088	Upper glass door, stripped, RH	1	1	1	1	1	1	1	1	1	1	1	1	1	1	1	1
2	561090	Lower glass door, stripped, RH	1	1	1	1	1	1	1	1	1	1	1	1	1	1	1	1
3	552682	Inner handle	1	1	1	1	1	1	1	1	1	1	1	1	1	1	1	1
4	600833	Door, stripped, RH	1	1	1	1	1	1	1	1	1	1	1	1	1	1	1	1
5	550153	Hinge	2	2	2	2	2	2	2	2	2	2	2	2	2	2	2	2
6	199961	Greaser	2	2	2	2	2	2	2	2	2	2	2	2	2	2	2	2
7	199963	Axle	2	2	2	2	2	2	2	2	2	2	2	2	2	2	2	2
8	549222	Hinge	2	2	2	2	2	2	2	2	2	2	2	2	2	2	2	2
9	600834	Door, RH, complete	1	1	1	1	1	1	1	1	1	1	1	1	1	1	1	1

8 AA 16

CAB DETAILS 6, 100 IN. FULLY ENCLOSED

M30-2	M30-4	M30-2 H	M30-4 H
M40-2	M40-4	M40-2 H	M40-4 H
M50-2	M50-4	M50-2 H	M50-4 H
M60-2	M60-4	M60-2 H	M60-4 H
M30-2 L	M30-4 L	M30-2 H L	M30-4 H L
M40-2 L	M40-4 L	M40-2 H L	M40-4 H L
M50-2 L	M50-4 L	M50-2 H L	M50-4 H L
M60-2 L	M60-4 L	M60-2 H L	M60-4 H L

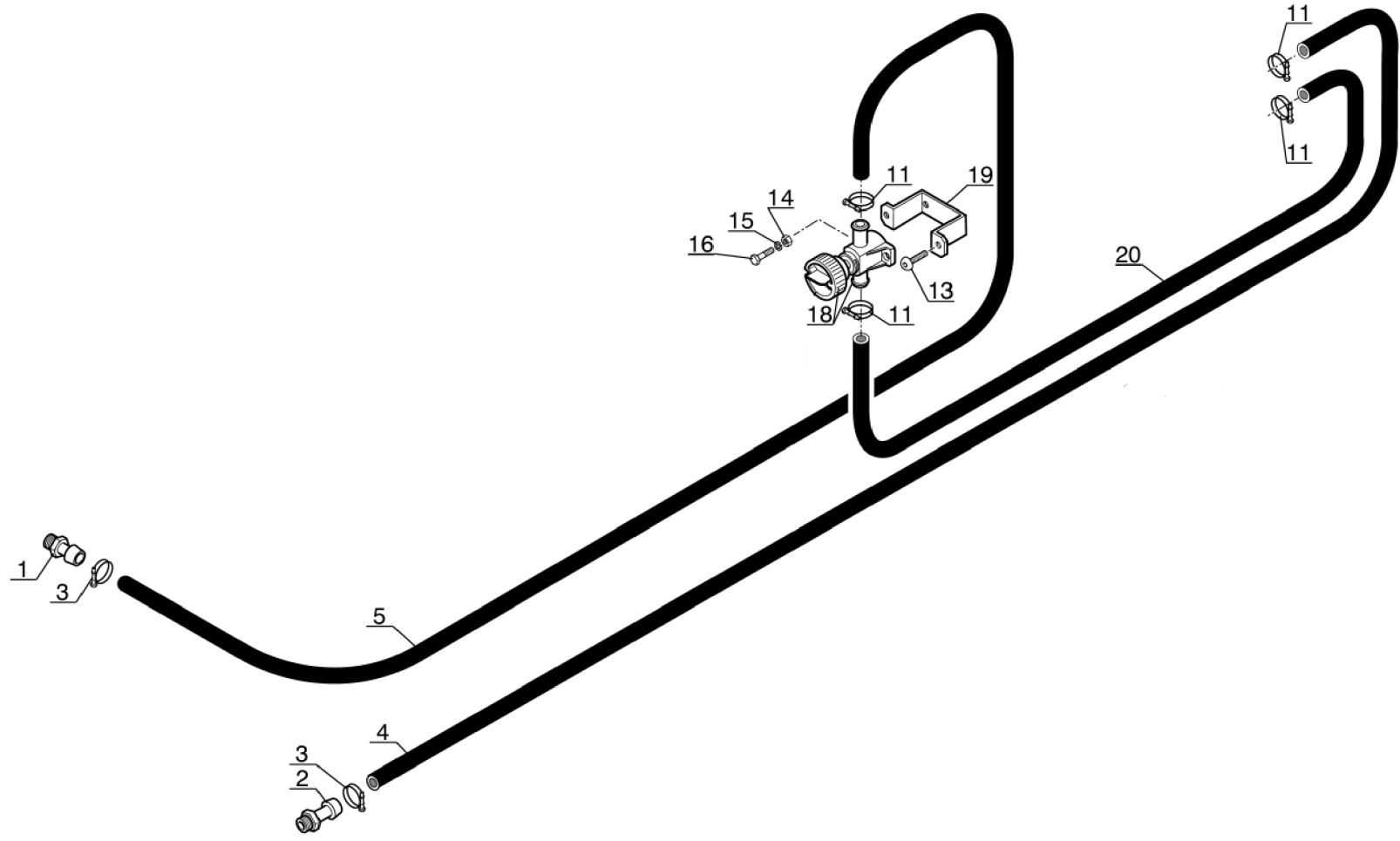

1	CAB DETAILS 6, 100 IN. FULLY ENCLOSED												8 AA 16						
	ITEM	PART NO.	DESCRIPTION	M30-2	M40-2	M50-2	M60-2	M30-2 H	M40-2 H	M50-2 H	M60-2 H	M30-2 L	M40-2 L	M50-2 L	M60-2 L	M30-2 H L	M40-2 H L	M50-2 H L	M60-2 H L
1	198059	Connection	1	1	1	1	1	1	1	1	1	1	1	1	1	1	1	1	1
2	198059	Connection	1	1	1	1	1	1	1	1	1	1	1	1	1	1	1	1	1
3	B2236-3	Clamp	2	2	2	2	2	2	2	2	2	2	2	2	2	2	2	2	2
4	802821	Heater hose	1	1	1	1	1	1	1	1	1	1	1	1	1	1	1	1	1
5	802820	Heater hose	1	1	1	1	1	1	1	1	1	1	1	1	1	1	1	1	1
11	B2236-3	Clamp	4	4	4	4	4	4	4	4	4	4	4	4	4	4	4	4	4
13	79533	Screw	2	2	2	2	2	2	2	2	2	2	2	2	2	2	2	2	2
14	54232	Nut	2	2	2	2	2	2	2	2	2	2	2	2	2	2	2	2	2
15	29483	Washer	2	2	2	2	2	2	2	2	2	2	2	2	2	2	2	2	2
16	4240	Screw	2	2	2	2	2	2	2	2	2	2	2	2	2	2	2	2	2
18	198060	Valve, heater	1	1	1	1	1	1	1	1	1	1	1	1	1	1	1	1	1
19	196821	Bracket	1	1	1	1	1	1	1	1	1	1	1	1	1	1	1	1	1
20	802822	Heater hose	1	1	1	1	1	1	1	1	1	1	1	1	1	1	1	1	1

8 AA 20

CAB ASSEMBLY, 100 IN. SEMI-ENCLOSED

M30-2	M30-4	M30-2 H	M30-4 H
M40-2	M40-4	M40-2 H	M40-4 H
M50-2	M50-4	M50-2 H	M50-4 H
M60-2	M60-4	M60-2 H	M60-4 H
M30-2 L	M30-4 L	M30-2 H L	M30-4 H L
M40-2 L	M40-4 L	M40-2 H L	M40-4 H L
M50-2 L	M50-4 L	M50-2 H L	M50-4 H L
M60-2 L	M60-4 L	M60-2 H L	M60-4 H L

CAB ASSEMBLY INCLUDES WIRING FOR CAB OPTIONS (BEACON, WORK LIGHTS, ETC.)

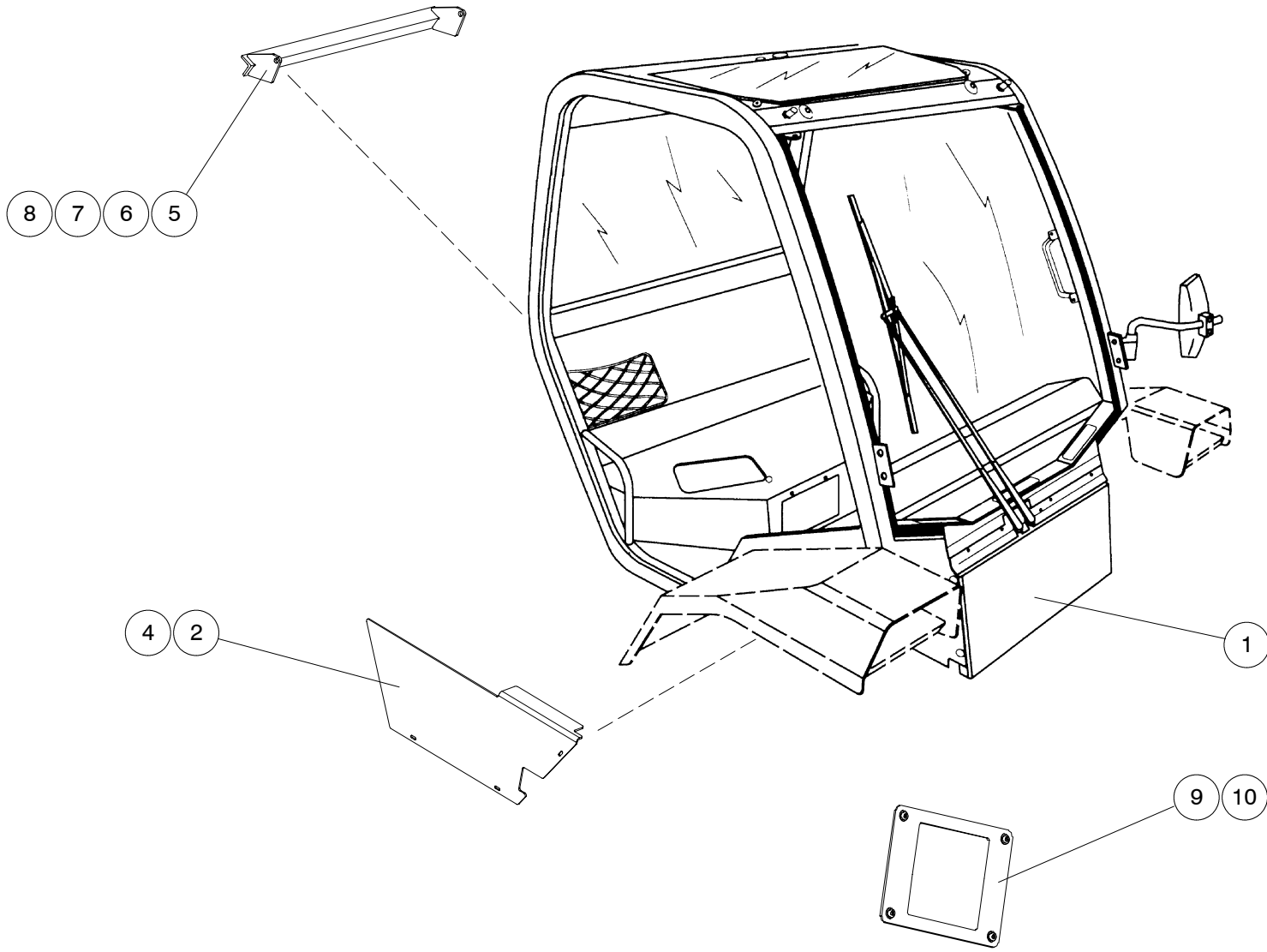

1	CAB ASSEMBLY, 100 IN. SEMI-ENCLOSED												8 AA 20						
	ITEM	PART NO.	DESCRIPTION	M30-2	M40-2	M50-2	M60-2	M30-2 H	M40-2 H	M50-2 H	M60-2 H	M30-2 L	M40-2 L	M50-2 L	M60-2 L	M30-2 H L	M40-2 H L	M50-2 H L	M60-2 H L
1	245776	Cab assembly, semi-enclosed - S/N: 750463 & above (DOES NOT include the front fenders or Items 2 thru 10)	1	1	1	1	1	1	1	1	1	1	1	1	1	1	1	1	1
2	802805	Cover, cab RH	1	1	1	1	1	1	1	1	1	1	1	1	1	1	1	1	1
3	802804	Cover, cab LH (not shown)	1	1	1	1	1	1	1	1	1	1	1	1	1	1	1	1	1
4	189172	Screw	6	6	6	6	6	6	6	6	6	6	6	6	6	6	6	6	6
5	802658	Cab angle assembly	1	1	1	1	1	1	1	1	1	1	1	1	1	1	1	1	1
6	29437	Washer, flat	4	4	4	4	4	4	4	4	4	4	4	4	4	4	4	4	4
7	56354	Nut	2	2	2	2	2	2	2	2	2	2	2	2	2	2	2	2	2
8	168354	Bolt	2	2	2	2	2	2	2	2	2	2	2	2	2	2	2	2	2
9	216355	Bracket, gauge	1	1	1	1	1	1	1	1	1	1	1	1	1	1	1	1	1
10	79533	Screw	4	4	4	4	4	4	4	4	4	4	4	4	4	4	4	4	4

8 AA 21

CAB DETAILS 1, 100 IN. SEMI-ENCLOSED

M30-2	M30-4	M30-2 H	M30-4 H
M40-2	M40-4	M40-2 H	M40-4 H
M50-2	M50-4	M50-2 H	M50-4 H
M60-2	M60-4	M60-2 H	M60-4 H
M30-2 L	M30-4 L	M30-2 H L	M30-4 H L
M40-2 L	M40-4 L	M40-2 H L	M40-4 H L
M50-2 L	M50-4 L	M50-2 H L	M50-4 H L
M60-2 L	M60-4 L	M60-2 H L	M60-4 H L

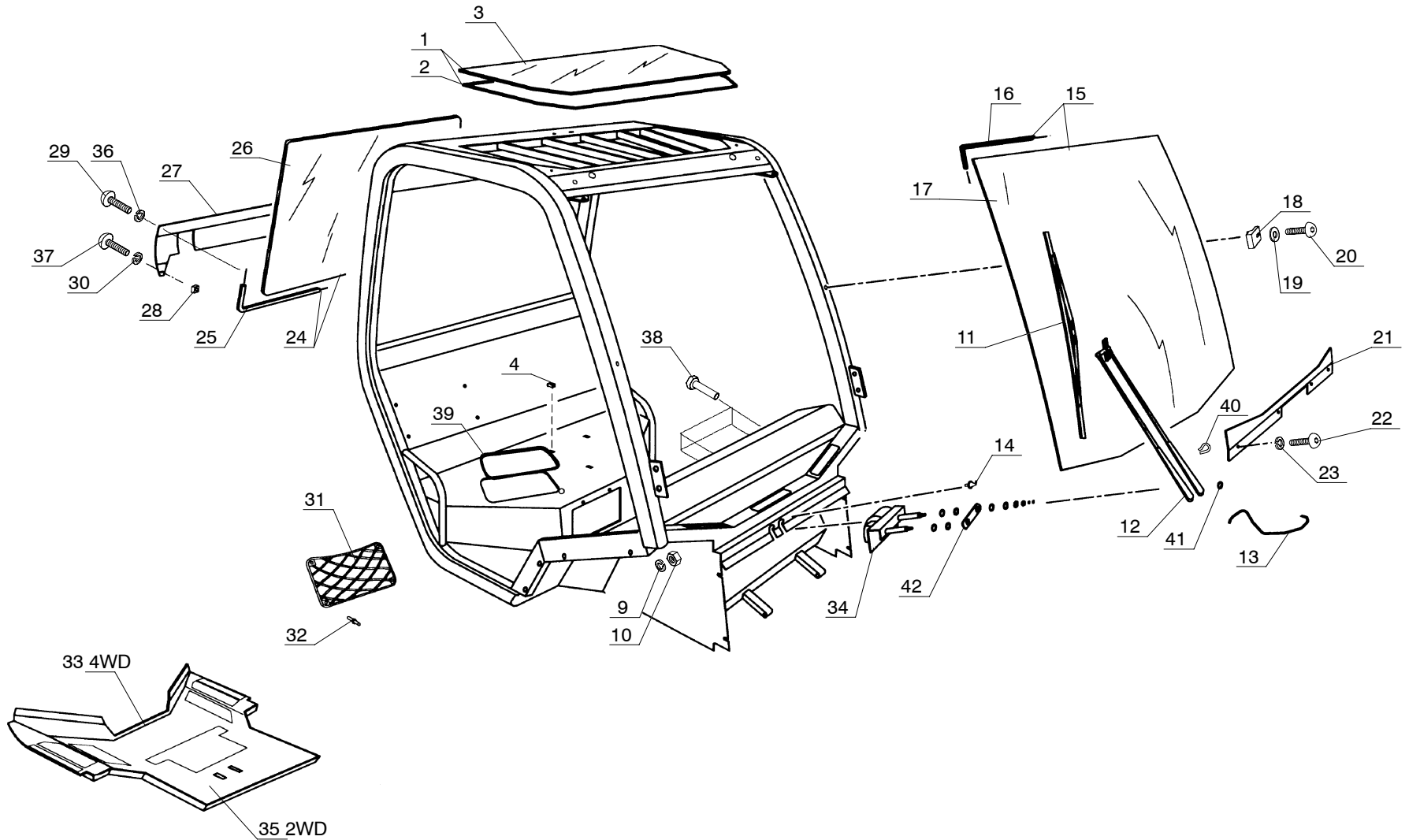

1	CAB DETAILS 1, 100 IN. SEMI-ENCLOSED											QUANTITY / MODEL						8 AA 21			
	ITEM	PART NO.	DESCRIPTION	M30-2	M40-2	M50-2	M60-2	M30-2 H	M40-2 H	M50-2 H	M60-2 H	M30-2 L	M40-2 L	M50-2 L	M60-2 L	M30-2 H L	M40-2 H L	M50-2 H L	M60-2 H L		
1	552426	Windshield, roof, w/ weatherstrip	1	1	1	1	1	1	1	1	1	1	1	1	1	1	1	1	1		
2	182038	Seal	1	1	1	1	1	1	1	1	1	1	1	1	1	1	1	1	1		
3	206271	Windshield, roof	1	1	1	1	1	1	1	1	1	1	1	1	1	1	1	1	1		
4	551882	Nut	12	12	12	12	12	12	12	12	12	12	12	12	12	12	12	12	12		
11	198290	Wiper blade	1	1	1	1	1	1	1	1	1	1	1	1	1	1	1	1	1		
12	561518	Blade holder	1	1	1	1	1	1	1	1	1	1	1	1	1	1	1	1	1		
13	199956	Hose	1	1	1	1	1	1	1	1	1	1	1	1	1	1	1	1	1		
14	199955	Connection	1	1	1	1	1	1	1	1	1	1	1	1	1	1	1	1	1		
15	561515	Windshield, front, w/ weatherstrip	1	1	1	1	1	1	1	1	1	1	1	1	1	1	1	1	1		
16	189752	Weatherstrip	1	1	1	1	1	1	1	1	1	1	1	1	1	1	1	1	1		
17	561086	Windshield, front	1	1	1	1	1	1	1	1	1	1	1	1	1	1	1	1	1		
18	552670	Fastening lug	2	2	2	2	2	2	2	2	2	2	2	2	2	2	2	2	2		
19	174132	Washer	2	2	2	2	2	2	2	2	2	2	2	2	2	2	2	2	2		
20	205275	Screw	2	2	2	2	2	2	2	2	2	2	2	2	2	2	2	2	2		
21	561519	Fastening plate	1	1	1	1	1	1	1	1	1	1	1	1	1	1	1	1	1		
22	183396	Screw	4	4	4	4	4	4	4	4	4	4	4	4	4	4	4	4	4		
23	194673	Washer	4	4	4	4	4	4	4	4	4	4	4	4	4	4	4	4	4		
24	561520	Windshield, rear, w/ weatherstrip	1	1	1	1	1	1	1	1	1	1	1	1	1	1	1	1	1		
25	182101	Weatherstrip	1	1	1	1	1	1	1	1	1	1	1	1	1	1	1	1	1		
26	561087	Windshield, rear	1	1	1	1	1	1	1	1	1	1	1	1	1	1	1	1	1		
27	561521	Fastening plate	1	1	1	1	1	1	1	1	1	1	1	1	1	1	1	1	1		
28	551880	Nut	5	5	5	5	5	5	5	5	5	5	5	5	5	5	5	5	5		
29	205275	Screw	3	3	3	3	3	3	3	3	3	3	3	3	3	3	3	3	3		
30	174132	Washer	2	2	2	2	2	2	2	2	2	2	2	2	2	2	2	2	2		

8 AA 22

CAB DETAILS 2, 100 IN. SEMI-ENCLOSED

M30-2	M30-4	M30-2 H	M30-4 H
M40-2	M40-4	M40-2 H	M40-4 H
M50-2	M50-4	M50-2 H	M50-4 H
M60-2	M60-4	M60-2 H	M60-4 H
M30-2 L	M30-4 L	M30-2 H L	M30-4 H L
M40-2 L	M40-4 L	M40-2 H L	M40-4 H L
M50-2 L	M50-4 L	M50-2 H L	M50-4 H L
M60-2 L	M60-4 L	M60-2 H L	M60-4 H L

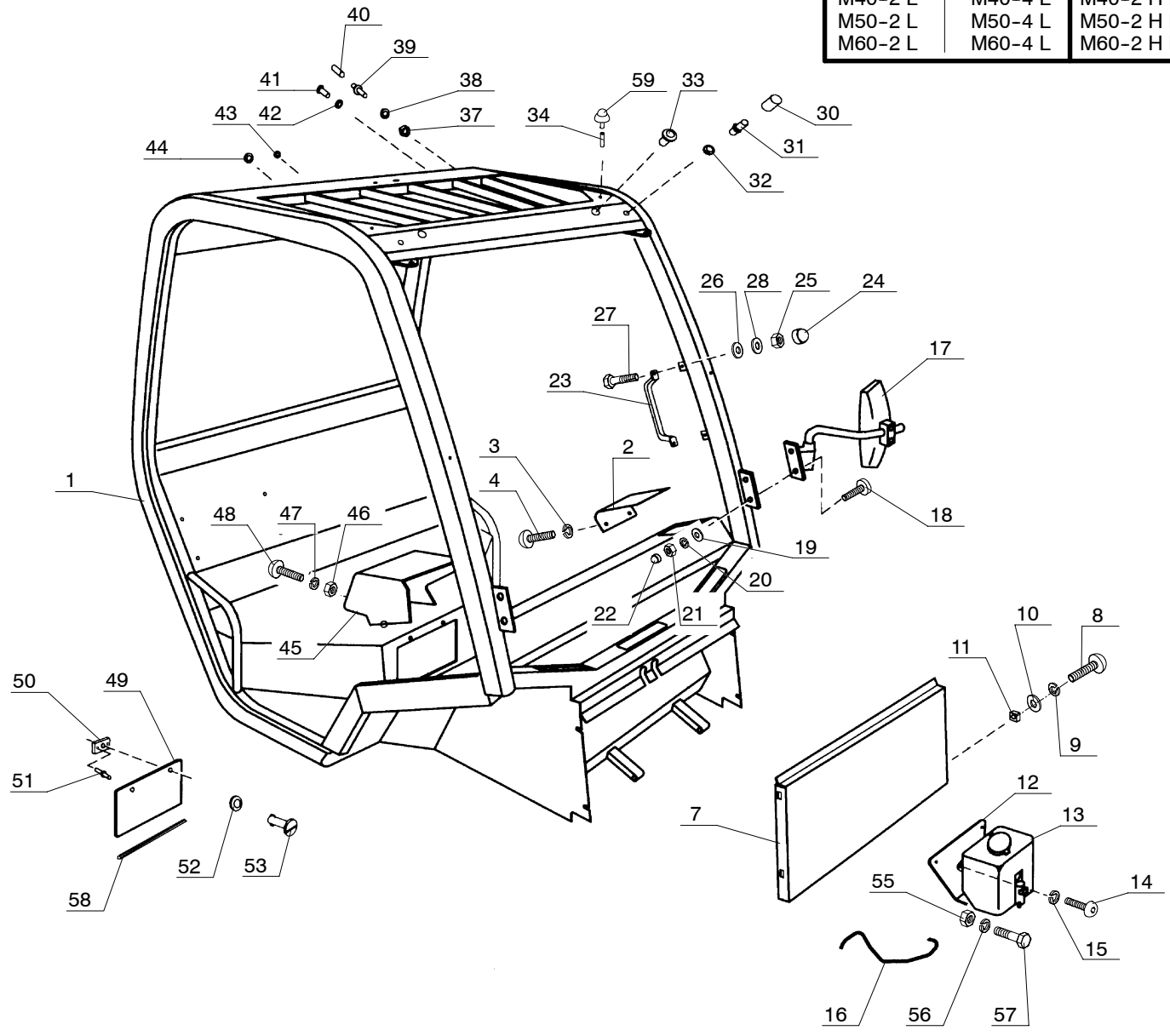

1	CAB DETAILS 2, 100 IN. SEMI-ENCLOSED		QUANTITY / MODEL											8 AA 22				
			M30-4	M40-4	M50-4	M60-4	M30-4 H	M40-4 H	M50-4 H	M60-4 H	M30-4 L	M40-4 L	M50-4 L	M60-4 L	M30-4 H L	M40-4 H L	M50-4 H L	M60-4 H L
ITEM	PART NO.	DESCRIPTION	M30-2	M40-2	M50-2	M60-2	M30-2 H	M40-2 H	M50-2 H	M60-2 H	M30-2 L	M40-2 L	M50-2 L	M60-2 L	M30-2 H L	M40-2 H L	M50-2 H L	M60-2 H L
1	603852	Cab frame	1	1	1	1	1	1	1	1	1	1	1	1	1	1	1	1
2	561524	Fastening plate	1	1	1	1	1	1	1	1	1	1	1	1	1	1	1	1
3	194673	Washer	2	2	2	2	2	2	2	2	2	2	2	2	2	2	2	2
4	183396	Screw	2	2	2	2	2	2	2	2	2	2	2	2	2	2	2	2
7	561525	Front fastening plate	1	1	1	1	1	1	1	1	1	1	1	1	1	1	1	1
8	202418	Screw	4	4	4	4	4	4	4	4	4	4	4	4	4	4	4	4
9	42325	Washer	4	4	4	4	4	4	4	4	4	4	4	4	4	4	4	4
10	61674	Washer	4	4	4	4	4	4	4	4	4	4	4	4	4	4	4	4
11	551882	Nut	4	4	4	4	4	4	4	4	4	4	4	4	4	4	4	4
12	201008	Bracket	1	1	1	1	1	1	1	1	1	1	1	1	1	1	1	1
13	190776	Windshield washer tank	1	1	1	1	1	1	1	1	1	1	1	1	1	1	1	1
14	79533	Screw	2	2	2	2	2	2	2	2	2	2	2	2	2	2	2	2
15	29483	Washer	2	2	2	2	2	2	2	2	2	2	2	2	2	2	2	2
16	561526	Hose	1	1	1	1	1	1	1	1	1	1	1	1	1	1	1	1
17A	561426	Rear view mirror, complete, LH	1	1	1	1	1	1	1	1	1	1	1	1	1	1	1	1
17B	572281ACC	Rear view mirror, complete RH	1	1	1	1	1	1	1	1	1	1	1	1	1	1	1	1
18	29441	Screw	2	2	2	2	2	2	2	2	2	2	2	2	2	2	2	2
19	29469	Washer	2	2	2	2	2	2	2	2	2	2	2	2	2	2	2	2
20	42316	Washer	2	2	2	2	2	2	2	2	2	2	2	2	2	2	2	2
21	25714	Nut	2	2	2	2	2	2	2	2	2	2	2	2	2	2	2	2
22	55404	Cap	2	2	2	2	2	2	2	2	2	2	2	2	2	2	2	2
23	195535	Handle	2	2	2	2	2	2	2	2	2	2	2	2	2	2	2	2
24	55404	Cap	4	4	4	4	4	4	4	4	4	4	4	4	4	4	4	4
25	25714	Nut	4	4	4	4	4	4	4	4	4	4	4	4	4	4	4	4
26	29469	Washer	4	4	4	4	4	4	4	4	4	4	4	4	4	4	4	4
27	46668	Screw	4	4	4	4	4	4	4	4	4	4	4	4	4	4	4	4
28	42316	Washer	4	4	4	4	4	4	4	4	4	4	4	4	4	4	4	4

8 AA 23

CAB DETAILS 3, 100 IN. SEMI-ENCLOSED

M30-2	M30-4	M30-2 H	M30-4 H
M40-2	M40-4	M40-2 H	M40-4 H
M50-2	M50-4	M50-2 H	M50-4 H
M60-2	M60-4	M60-2 H	M60-4 H
M30-2 L	M30-4 L	M30-2 H L	M30-4 H L
M40-2 L	M40-4 L	M40-2 H L	M40-4 H L
M50-2 L	M50-4 L	M50-2 H L	M50-4 H L
M60-2 L	M60-4 L	M60-2 H L	M60-4 H L

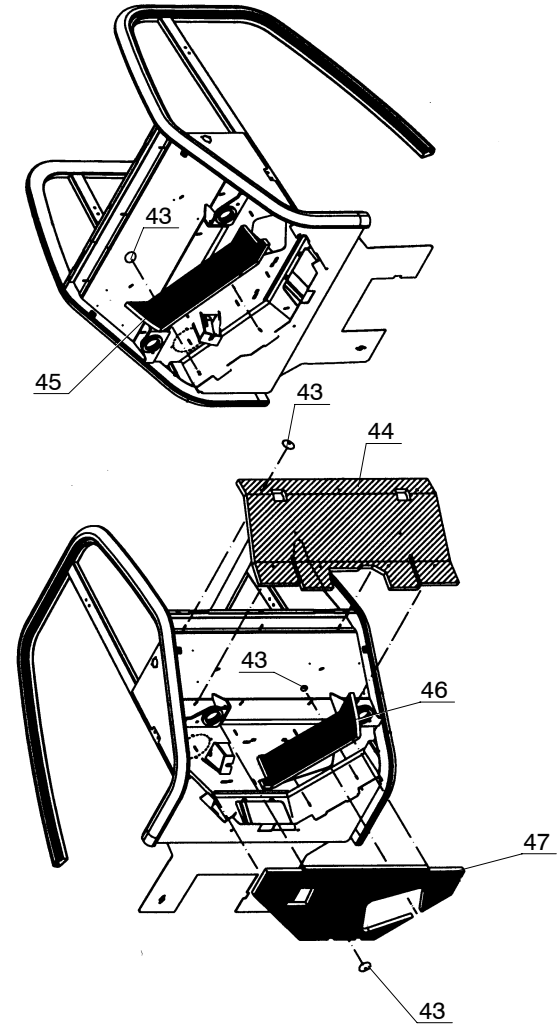
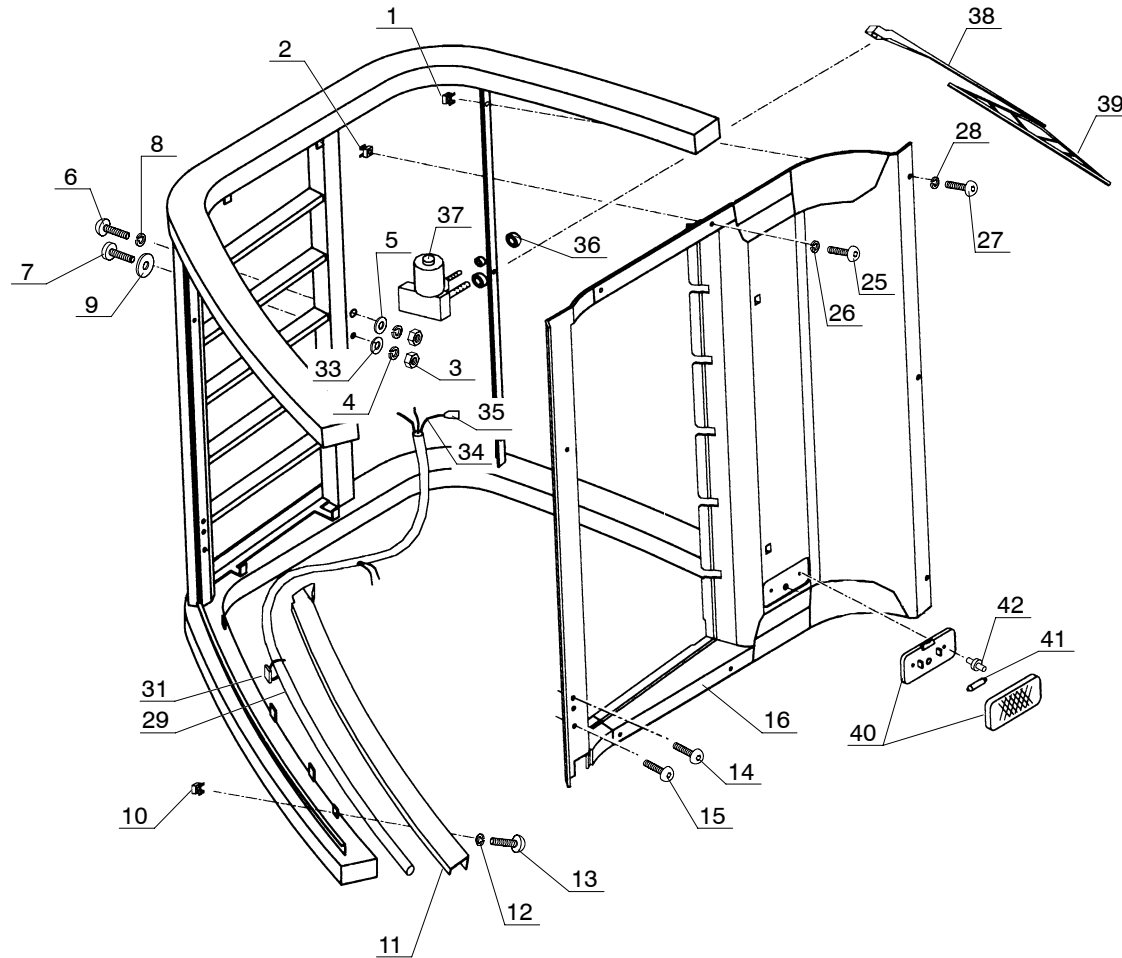

1	CAB DETAILS 3, 100 IN. SEMI-ENCLOSED		QUANTITY / MODEL												8 AA 23			
			M30-4	M40-4	M50-4	M60-4	M30-4 H	M40-4 H	M50-4 H	M60-4 H	M30-4 L	M40-4 L	M50-4 L	M60-4 L	M30-4 H L	M40-4 H L	M50-4 H L	M60-4 H L
ITEM	PART NO.	DESCRIPTION	M30-2	M40-2	M50-2	M60-2	M30-2 H	M40-2 H	M50-2 H	M60-2 H	M30-2 L	M40-2 L	M50-2 L	M60-2 L	M30-2 H L	M40-2 H L	M50-2 H L	M60-2 H L
1	551582	Nut	3	3	3	3	3	3	3	3	3	3	3	3	3	3	3	3
2	551582	Nut	4	4	4	4	4	4	4	4	4	4	4	4	4	4	4	4
3	58528	Nut	2	2	2	2	2	2	2	2	2	2	2	2	2	2	2	2
4	42325	Washer	2	2	2	2	2	2	2	2	2	2	2	2	2	2	2	2
5	61674	Washer	1	1	1	1	1	1	1	1	1	1	1	1	1	1	1	1
6	202144	Screw	1	1	1	1	1	1	1	1	1	1	1	1	1	1	1	1
7	42412	Screw	1	1	1	1	1	1	1	1	1	1	1	1	1	1	1	1
8	194661	Washer	1	1	1	1	1	1	1	1	1	1	1	1	1	1	1	1
9	551560	Washer	1	1	1	1	1	1	1	1	1	1	1	1	1	1	1	1
10	551582	Nut	2	2	2	2	2	2	2	2	2	2	2	2	2	2	2	2
11	561528	Drain trough	1	1	1	1	1	1	1	1	1	1	1	1	1	1	1	1
12	551600	Washer	2	2	2	2	2	2	2	2	2	2	2	2	2	2	2	2
13	199976	Screw	2	2	2	2	2	2	2	2	2	2	2	2	2	2	2	2
14	194668	Screw	2	2	2	2	2	2	2	2	2	2	2	2	2	2	2	2
15	205275	Screw	2	2	2	2	2	2	2	2	2	2	2	2	2	2	2	2
16	561529	Roof fittings	1	1	1	1	1	1	1	1	1	1	1	1	1	1	1	1
25	199976	Screw	4	4	4	4	4	4	4	4	4	4	4	4	4	4	4	4
26	551600	Washer	4	4	4	4	4	4	4	4	4	4	4	4	4	4	4	4
27	199976	Screw	7	7	7	7	7	7	7	7	7	7	7	7	7	7	7	7
28	551600	Washer	7	7	7	7	7	7	7	7	7	7	7	7	7	7	7	7
29	603306	Wiring harness	1	1	1	1	1	1	1	1	1	1	1	1	1	1	1	1
31	561531	Clip	1	1	1	1	1	1	1	1	1	1	1	1	1	1	1	1
33	562051	Washer	1	1	1	1	1	1	1	1	1	1	1	1	1	1	1	1
34	561342	Cable terminal	10	10	10	10	10	10	10	10	10	10	10	10	10	10	10	10
35	562665	Plug	10	10	10	10	10	10	10	10	10	10	10	10	10	10	10	10

8 AA 30

CAB ASSEMBLY, 100 IN. OPEN

CAB ASSEMBLY INCLUDES WIRING FOR CAB OPTIONS
(BEACON, WORK LIGHTS, ETC. - SEE ITEM 13)

M30-2	M30-4	M30-2 H	M30-4 H
M40-2	M40-4	M40-2 H	M40-4 H
M50-2	M50-4	M50-2 H	M50-4 H
M60-2	M60-4	M60-2 H	M60-4 H
M30-2 L	M30-4 L	M30-2 H L	M30-4 H L
M40-2 L	M40-4 L	M40-2 H L	M40-4 H L
M50-2 L	M50-4 L	M50-2 H L	M50-4 H L
M60-2 L	M60-4 L	M60-2 H L	M60-4 H L

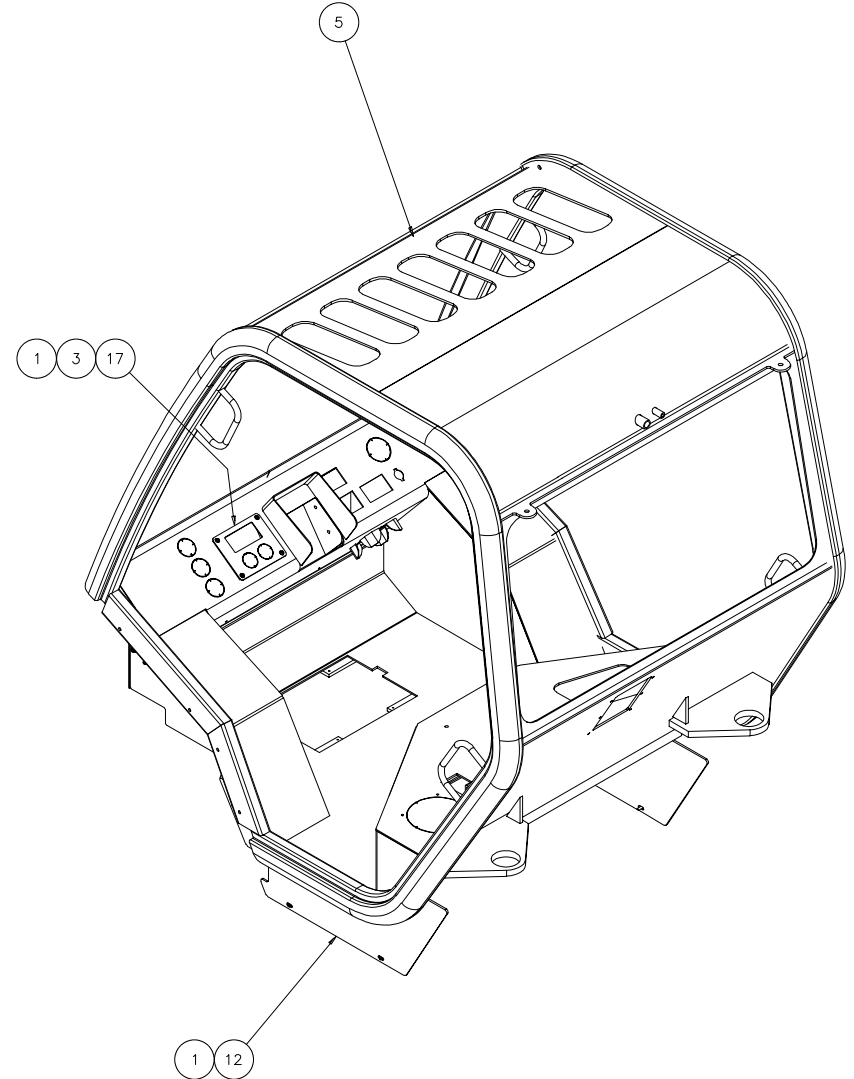
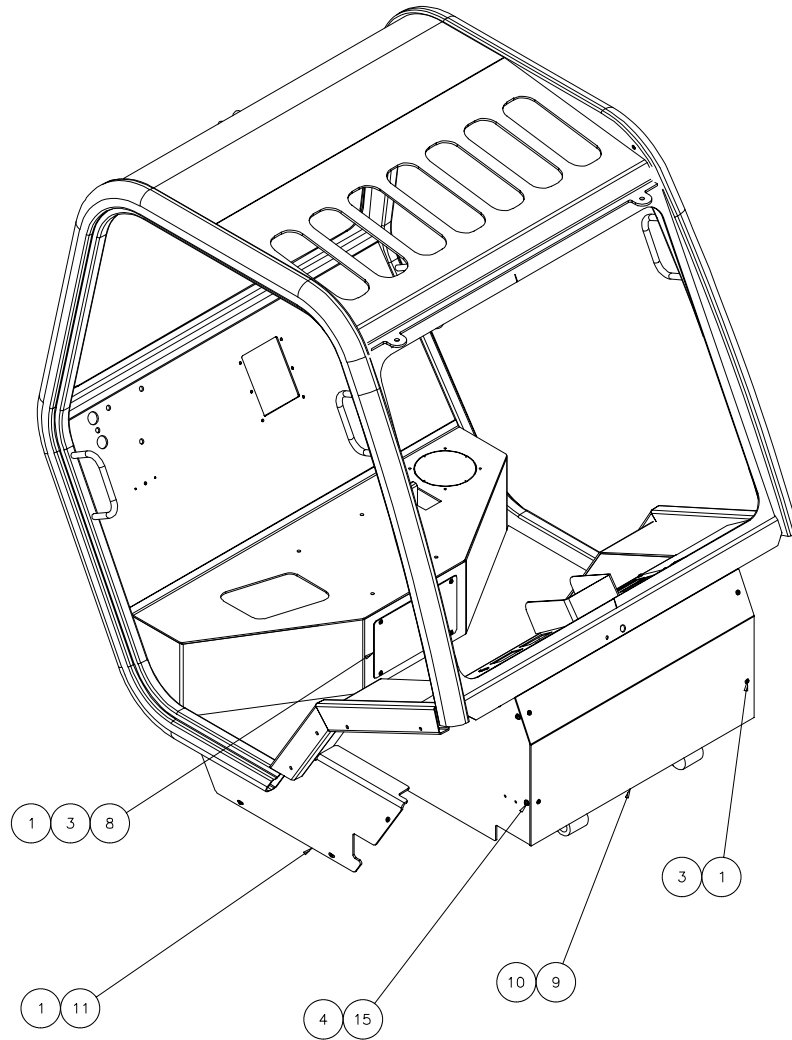

1	CAB ASSEMBLY, 100 IN. OPEN													8 AA 30					
	ITEM	PART NO.	DESCRIPTION	M30-4	M40-4	M50-4	M60-4	M30-4 H	M40-4 H	M50-4 H	M60-4 H	M30-4 L	M40-4 L	M50-4 L	M60-4 L	M30-4 H L	M40-4 H L	M50-4 H L	M60-4 H L
1	189172	Screw	20	20	20	20	20	20	20	20	20	20	20	20	20	20	20	20	20
3	29469	Washer	16	16	16	16	16	16	16	16	16	16	16	16	16	16	16	16	16
4	61674	Washer	4	4	4	4	4	4	4	4	4	4	4	4	4	4	4	4	4
5A	802656	Cab assembly, 100 in. open, S/N: 181964-750185	1	1	1	1	1	1	1	1	1	1	1	1	1	1	1	1	1
5B	803746	Cab assembly, 100 in. open, S/N: 750186-750474	1	1	1	1	1	1	1	1	1	1	1	1	1	1	1	1	1
5C	804295	Cab assembly, 100 in. open, S/N: 750475 & above	1	1	1	1	1	1	1	1	1	1	1	1	1	1	1	1	1
8	802756	Plate, cover, 1st mounting	1	1	1	1	1	1	1	1	1	1	1	1	1	1	1	1	1
9	802757	Cover, front	1	1	1	1	1	1	1	1	1	1	1	1	1	1	1	1	1
10	802771	Angle	4	4	4	4	4	4	4	4	4	4	4	4	4	4	4	4	4
11	802805	Cover, cab RH	1	1	1	1	1	1	1	1	1	1	1	1	1	1	1	1	1
12	802804	Cover, cab LH	1	1	1	1	1	1	1	1	1	1	1	1	1	1	1	1	1
13	802861	Harness, cab - see 11CC10	1	1	1	1	1	1	1	1	1	1	1	1	1	1	1	1	1
14	25714	Nut	2	2	2	2	2	2	2	2	2	2	2	2	2	2	2	2	2
15	202731	Screw	4	4	4	4	4	4	4	4	4	4	4	4	4	4	4	4	4
17A	802826	Plate, gauges (rectangle gauges), 1st mounting	1	1	1	1	1	1	1	1	1	1	1	1	1	1	1	1	1
17B	802755	Plate, gauges (rectangle and round gauges), 2nd mounting	1	1	1	1	1	1	1	1	1	1	1	1	1	1	1	1	1

8 AA 40

CAB ASSEMBLY, 77 & 81 IN. 4-SPEED

M30-2	M30-4		
M40-2	M40-4		
M50-2	M50-4		
M60-2	M60-4		
M30-2 L	M30-4 L		
M40-2 L	M40-4 L		
M50-2 L	M50-4 L		
M60-2 L	M60-4 L		

CAB ASSEMBLY INCLUDES WIRING FOR CAB OPTIONS
(BEACON, WORK LIGHTS, ETC. - SEE ITEM 8)

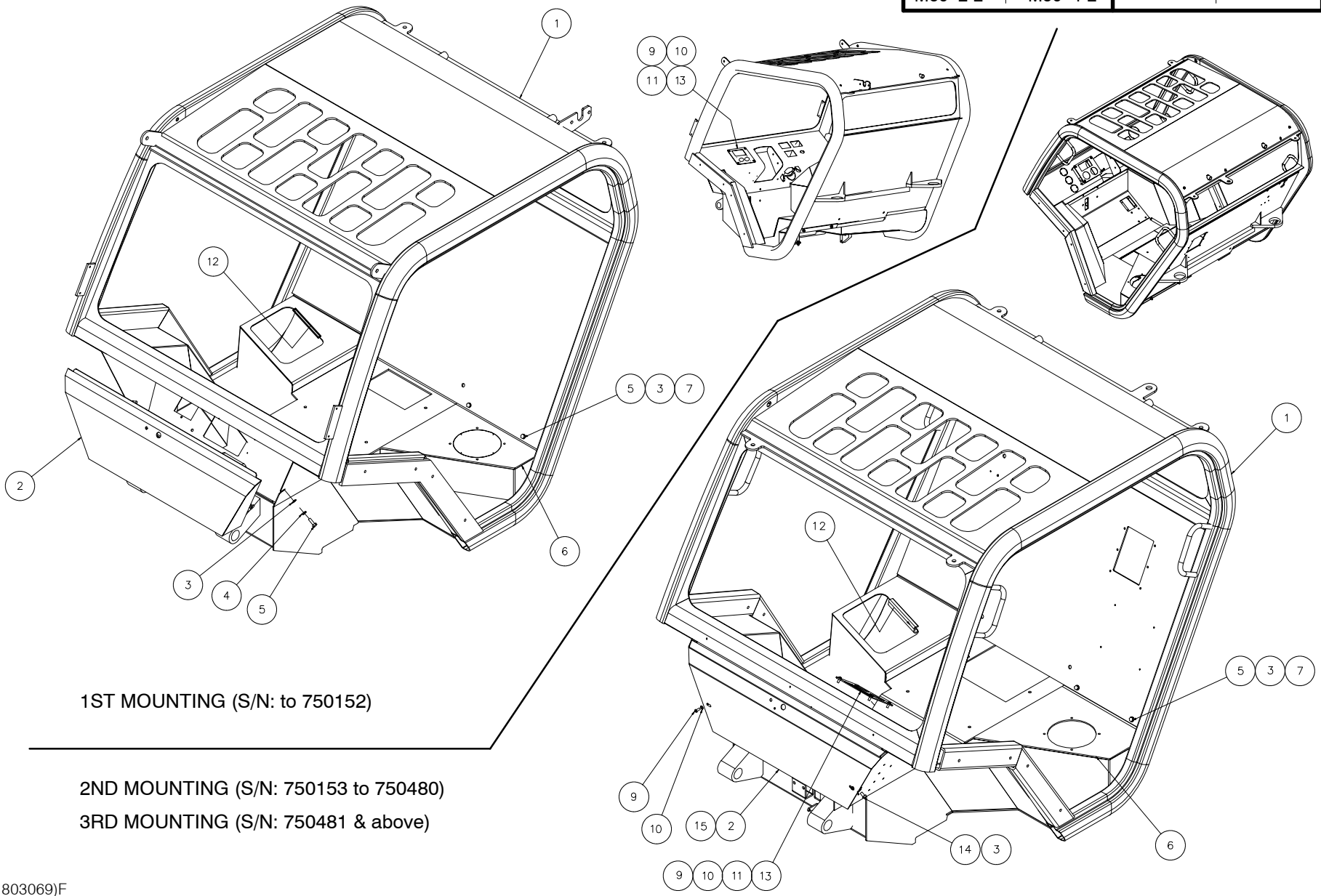

1ST MOUNTING (S/N: to 750152)

2ND MOUNTING (S/N: 750153 to 750480)

3RD MOUNTING (S/N: 750481 & above)

1	CAB ASSEMBLY, 77 & 81 IN. 4-SPEED											QUANTITY / MODEL				8 AA 40			
	ITEM	PART NO.	DESCRIPTION	M30-4	M40-4	M50-4	M60-4					M30-4 L	M40-4 L	M50-4 L	M60-4 L				
1A	802972	Cab assembly, 1st mounting - S/N: to 750152	1	1	1	1					1	1	1	1					
1B	803562	Cab assembly, 2nd mounting - S/N: 750153 to 750480	1	1	1	1					1	1	1	1					
1C	804252	Cab assembly, 3rd mounting - S/N: 750481 & above	1	1	1	1					1	1	1	1					
2A	802852	Cowling, S/N: to 750152	1	1	1	1					1	1	1	1					
2B	803663	Cover, front, S/N: 750153 & above	1	1	1	1					1	1	1	1					
3	61674	Washer, flat	10	10	10	10					10	10	10	10					
4	42325	Washer, lock	2	2	2	2					2	2	2	2					
5	57446	Bolt	6	6	6	6					6	6	6	6					
6A	803058	Cover assembly, 4-speed models only - S/N: to 750152	1	1	1	1					1	1	1	1					
6B	804272	Cover assembly, 4-speed models only - 750153 & above	1	1	1	1					1	1	1	1					
7	58528	Nut	4	4	4	4					4	4	4	4					
8	802861	Harness, cab - see 11CC10	1	1	1	1					1	1	1	1					
9	189172	Screw	4	4	4	4					4	4	4	4					
10	29469	Washer, flat	4	4	4	4					4	4	4	4					
11	25714	Nut	4	4	4	4					4	4	4	4					
12	803393	Seal	1	1	1	1					1	1	1	1					
13	802755	Plate, gauge	1	1	1	1					1	1	1	1					
14	202731	Screw	2	2	2	2					2	2	2	2					
15	802771	Angle	2	2	2	2					2	2	2	2					

8 AA 50

CAB ASSEMBLY, 77 & 81 IN. HYDROSTATIC

M30-2 H	M30-4 H
M40-2 H	M40-4 H
M50-2 H	M50-4 H
M60-2 H	M60-4 H

M30-2 H L	M30-4 H L
M40-2 H L	M40-4 H L
M50-2 H L	M50-4 H L
M60-2 H L	M60-4 H L

CAB ASSEMBLY INCLUDES WIRING FOR CAB OPTIONS
(BEACON, WORK LIGHTS, ETC. - SEE ITEM 7)

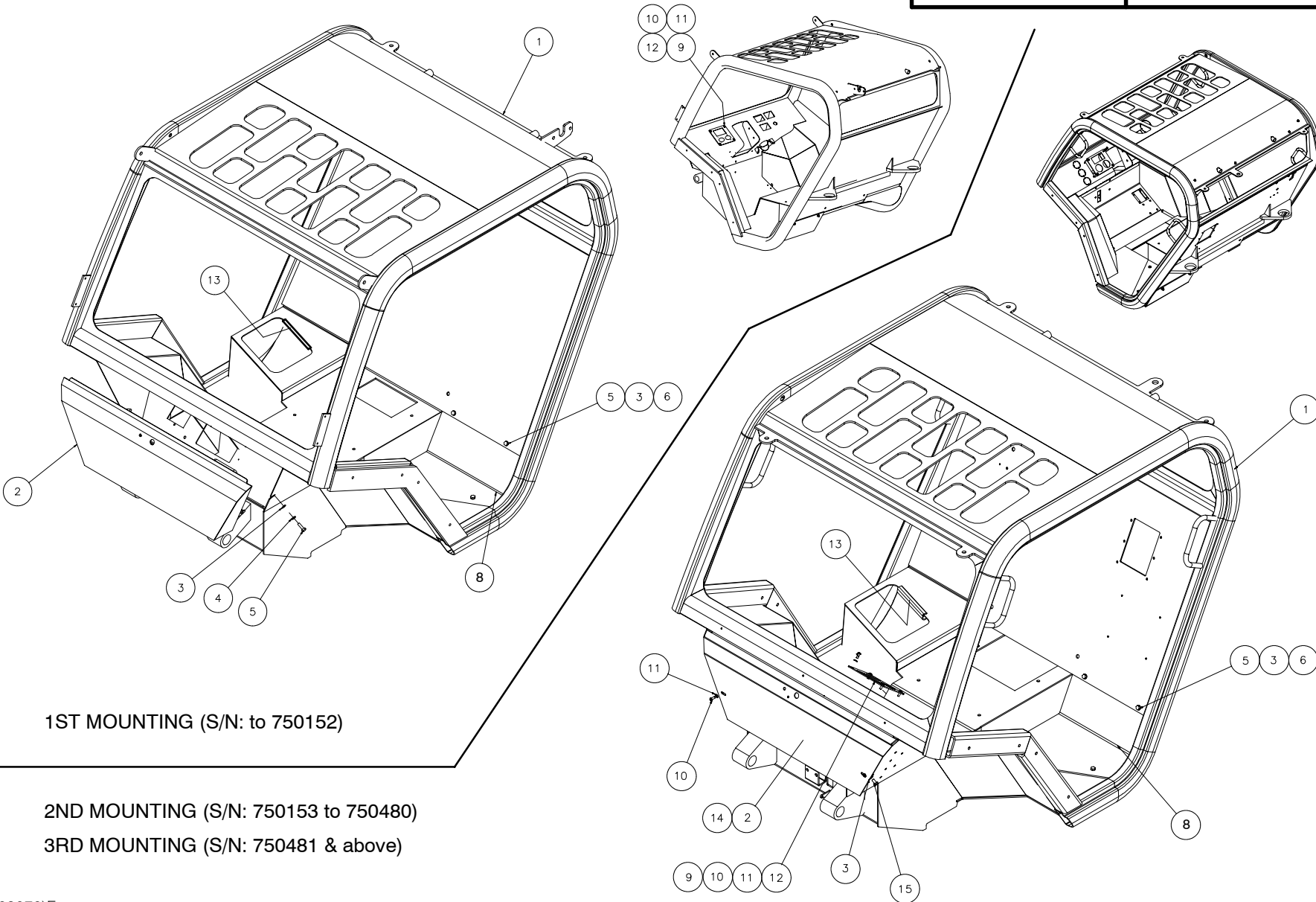

1ST MOUNTING (S/N: to 750152)

2ND MOUNTING (S/N: 750153 to 750480)

3RD MOUNTING (S/N: 750481 & above)

1	CAB ASSEMBLY, 77 & 81 IN. HYDROSTATIC		QUANTITY / MODEL								8 AA 50			
											M30-4 H L	M40-4 H L	M50-4 H L	M60-4 H L
ITEM	PART NO.	DESCRIPTION	M30-2 H	M40-2 H	M50-2 H	M60-2 H					M30-2 H L	M40-2 H L	M50-2 H L	M60-2 H L
1A	802972	Cab assembly, 1st mounting - S/N: to 750152	1	1	1	1					1	1	1	1
1B	803562	Cab assembly, 2nd mounting - S/N: 750153 to 750480	1	1	1	1					1	1	1	1
1C	804252	Cab assembly, 3rd mounting - S/N: 750481 & above	1	1	1	1					1	1	1	1
2A	802852	Cowling, S/N: to 750152	1	1	1	1					1	1	1	1
2B	803663	Cover, front, S/N: 750153 & above	1	1	1	1					1	1	1	1
3	61674	Washer, flat	10	10	10	10					10	10	10	10
4	42325	Washer, lock	2	2	2	2					2	2	2	2
5	57446	Bolt	6	6	6	6					6	6	6	6
6	58528	Nut	4	4	4	4					4	4	4	4
7	802861	Harness, cab - see 11CC10	1	1	1	1					1	1	1	1
8A	803047	Cover assembly, hydrostatic models only - S/N: to 750152	1	1	1	1					1	1	1	1
8B	804274	Cover assembly, hydrostatic models only - S/N: 750153 & above	1	1	1	1					1	1	1	1
9	802755	Plate, gauges	1	1	1	1					1	1	1	1
10	189172	Screw	4	4	4	4					4	4	4	4
11	29469	Washer, flat	4	4	4	4					4	4	4	4
12	25714	Nut	4	4	4	4					4	4	4	4
13	803393	Seal	1	1	1	1					1	1	1	1
14	802771	Angle	2	2	2	2					2	2	2	2
15	202731	Screw	2	2	2	2					2	2	2	2

8 AA 100

CAB MOUNTING ASSEMBLY

M30-2	M30-4	M30-2 H	M30-4 H
M40-2	M40-4	M40-2 H	M40-4 H
M50-2	M50-4	M50-2 H	M50-4 H
M60-2	M60-4	M60-2 H	M60-4 H
M30-2 L	M30-4 L	M30-2 H L	M30-4 H L
M40-2 L	M40-4 L	M40-2 H L	M40-4 H L
M50-2 L	M50-4 L	M50-2 H L	M50-4 H L
M60-2 L	M60-4 L	M60-2 H L	M60-4 H L

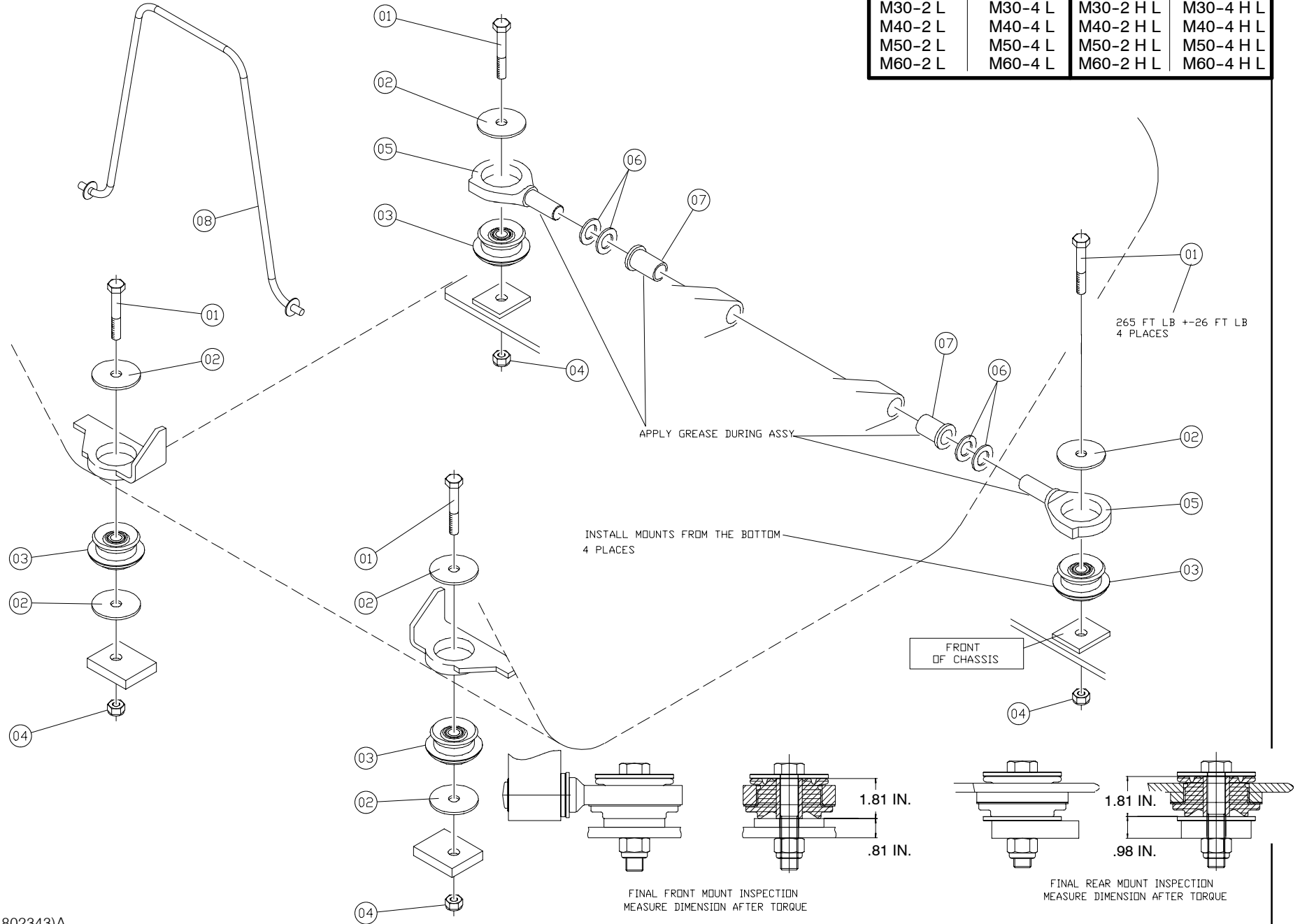

1	CAB MOUNTING ASSEMBLY												8 AA 100						
	ITEM	PART NO.	DESCRIPTION	M30-2	M40-2	M50-2	M60-2	M30-2 H	M40-2 H	M50-2 H	M60-2 H	M30-2 L	M40-2 L	M50-2 L	M60-2 L	M30-2 H L	M40-2 H L	M50-2 H L	M60-2 H L
1	58633	Bolt	4	4	4	4	4	4	4	4	4	4	4	4	4	4	4	4	4
2	210006	Washer, flat	6	6	6	6	6	6	6	6	6	6	6	6	6	6	6	6	6
3	209113	Rubber mount	4	4	4	4	4	4	4	4	4	4	4	4	4	4	4	4	4
4	185054	Nut	4	4	4	4	4	4	4	4	4	4	4	4	4	4	4	4	4
5	207783	Bracket, cab mounting	2	2	2	2	2	2	2	2	2	2	2	2	2	2	2	2	2
6	202947	Washer	4	4	4	4	4	4	4	4	4	4	4	4	4	4	4	4	4
7	210005	Bushing	2	2	2	2	2	2	2	2	2	2	2	2	2	2	2	2	2
8	802470	Tilt stand	1	1	1	1	1	1	1	1	1	1	1	1	1	1	1	1	1

8 AA 101

STEERING COLUMN ASSEMBLY, 100 IN. SEMI & FULLY ENCLOSED CAB

M30-2	M30-4	M30-2 H	M30-4 H
M40-2	M40-4	M40-2 H	M40-4 H
M50-2	M50-4	M50-2 H	M50-4 H
M60-2	M60-4	M60-2 H	M60-4 H
M30-2 L	M30-4 L	M30-2 H L	M30-4 H L
M40-2 L	M40-4 L	M40-2 H L	M40-4 H L
M50-2 L	M50-4 L	M50-2 H L	M50-4 H L
M60-2 L	M60-4 L	M60-2 H L	M60-4 H L

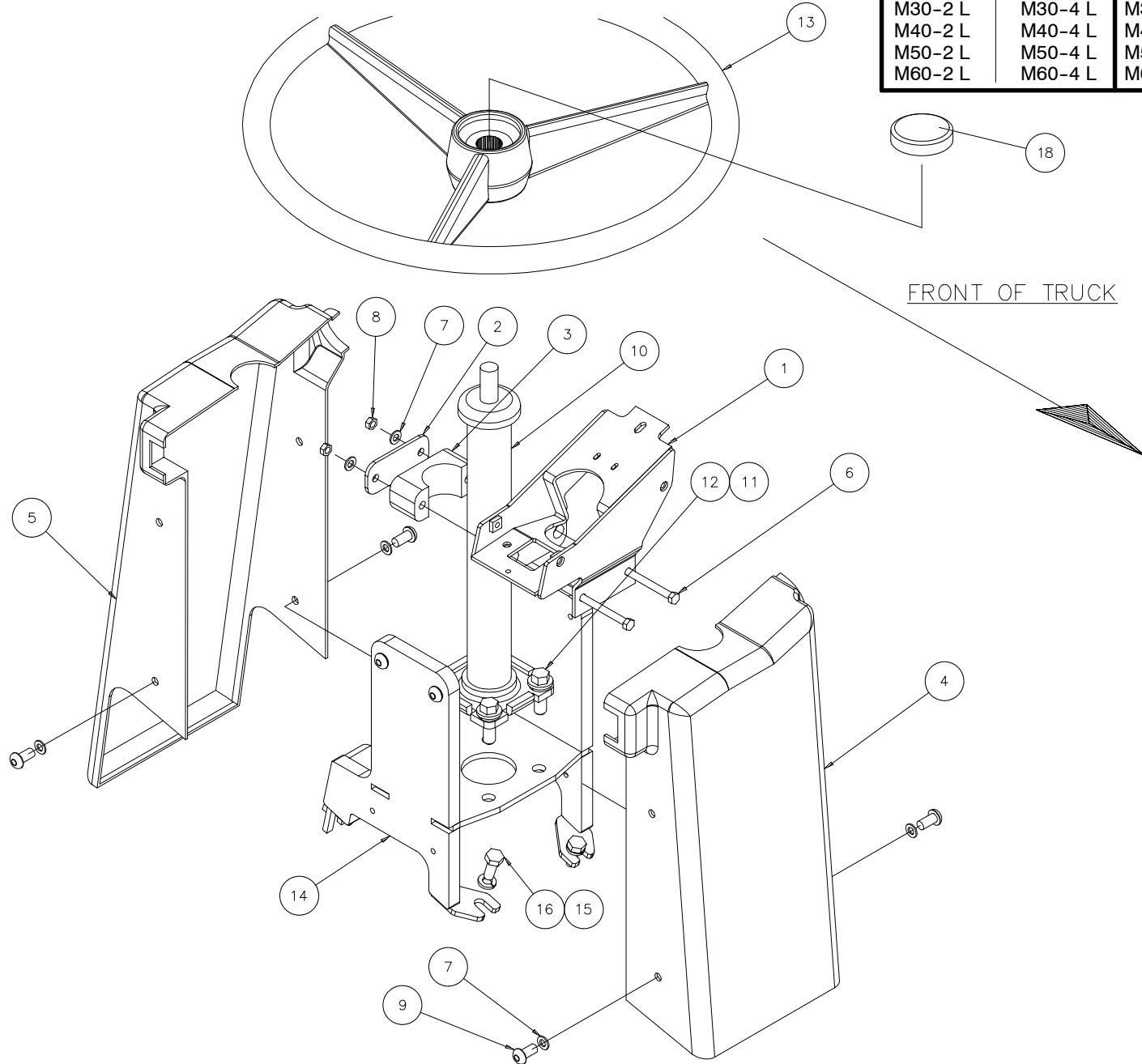

1	STEERING COLUMN ASSEMBLY, 100 IN. SEMI & FULLY ENCLOSED CAB														8 AA 101				
	ITEM	PART NO.	DESCRIPTION	M30-2	M40-2	M50-2	M60-2	M30-2 H	M40-2 H	M50-2 H	M60-2 H	M30-2 L	M40-2 L	M50-2 L	M60-2 L	M30-2 H L	M40-2 H L	M50-2 H L	M60-2 H L
1	203115	Bracket, steering column	1	1	1	1	1	1	1	1	1	1	1	1	1	1	1	1	1
2	168870	Plate, cover	1	1	1	1	1	1	1	1	1	1	1	1	1	1	1	1	1
3	174321	Clamp, hose half	2	2	2	2	2	2	2	2	2	2	2	2	2	2	2	2	2
4	202953	Cover, column front	1	1	1	1	1	1	1	1	1	1	1	1	1	1	1	1	1
5	202954	Cover, column rear	1	1	1	1	1	1	1	1	1	1	1	1	1	1	1	1	1
6	165919	Bolt	2	2	2	2	2	2	2	2	2	2	2	2	2	2	2	2	2
7	29469	Washer, flat	2	2	2	2	2	2	2	2	2	2	2	2	2	2	2	2	2
8	162229	Nut	2	2	2	2	2	2	2	2	2	2	2	2	2	2	2	2	2
9	196951	Screw	8	8	8	8	8	8	8	8	8	8	8	8	8	8	8	8	8
10	30327	Column, steering	1	1	1	1	1	1	1	1	1	1	1	1	1	1	1	1	1
11	42232	Washer, lock	4	4	4	4	4	4	4	4	4	4	4	4	4	4	4	4	4
12	63544	Bolt	4	4	4	4	4	4	4	4	4	4	4	4	4	4	4	4	4
13	191613	Steering wheel	1	1	1	1	1	1	1	1	1	1	1	1	1	1	1	1	1
14	216000	Bracket, steering	1	1	1	1	1	1	1	1	1	1	1	1	1	1	1	1	1
15	42325	Washer, lock	4	4	4	4	4	4	4	4	4	4	4	4	4	4	4	4	4
16	42347	Bolt	4	4	4	4	4	4	4	4	4	4	4	4	4	4	4	4	4
17	195069	Steering wheel cap	1	1	1	1	1	1	1	1	1	1	1	1	1	1	1	1	1

8 AA 102

STEERING COLUMN ASSEMBLY, 100 IN. OPEN CAB

M30-2	M30-4	M30-2 H	M30-4 H
M40-2	M40-4	M40-2 H	M40-4 H
M50-2	M50-4	M50-2 H	M50-4 H
M60-2	M60-4	M60-2 H	M60-4 H
M30-2 L	M30-4 L	M30-2 H L	M30-4 H L
M40-2 L	M40-4 L	M40-2 H L	M40-4 H L
M50-2 L	M50-4 L	M50-2 H L	M50-4 H L
M60-2 L	M60-4 L	M60-2 H L	M60-4 H L

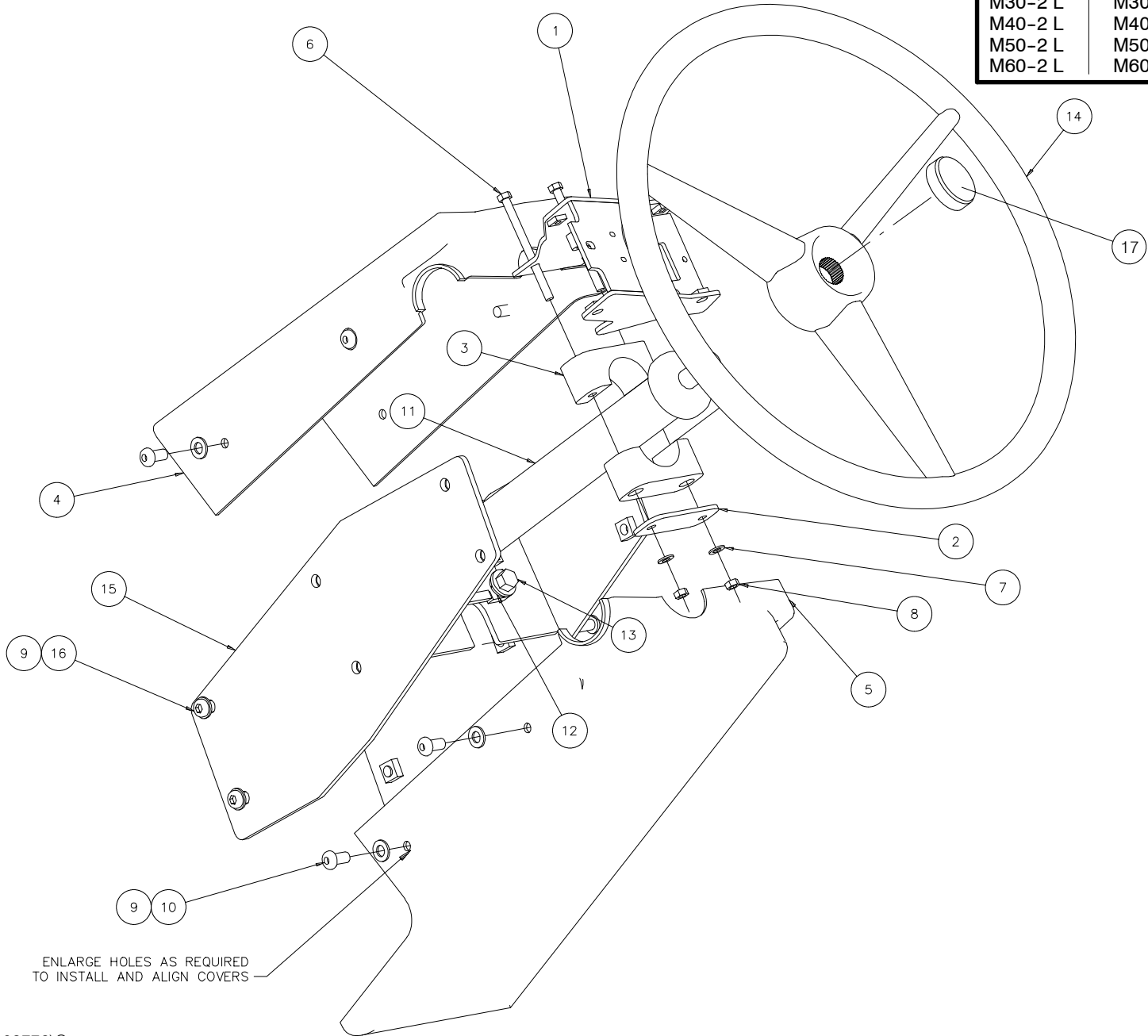

ENLARGE HOLES AS REQUIRED TO INSTALL AND ALIGN COVERS

1	STEERING COLUMN ASSEMBLY, 100 IN. OPEN CAB												8 AA 102						
	ITEM	PART NO.	DESCRIPTION	M30-2	M40-2	M50-2	M60-2	M30-2 H	M40-2 H	M50-2 H	M60-2 H	M30-2 L	M40-2 L	M50-2 L	M60-2 L	M30-2 H L	M40-2 H L	M50-2 H L	M60-2 H L
1	203115	Bracket, steering column	1	1	1	1	1	1	1	1	1	1	1	1	1	1	1	1	1
2	168870	Plate, cover	1	1	1	1	1	1	1	1	1	1	1	1	1	1	1	1	1
3	174321	Clamp, hose half	2	2	2	2	2	2	2	2	2	2	2	2	2	2	2	2	2
4	202953	Cover, column front	1	1	1	1	1	1	1	1	1	1	1	1	1	1	1	1	1
5	202954	Cover, column rear	1	1	1	1	1	1	1	1	1	1	1	1	1	1	1	1	1
6	165919	Bolt	2	2	2	2	2	2	2	2	2	2	2	2	2	2	2	2	2
7	29469	Washer, flat	2	2	2	2	2	2	2	2	2	2	2	2	2	2	2	2	2
8	162229	Nut	2	2	2	2	2	2	2	2	2	2	2	2	2	2	2	2	2
9	61674	Washer, flat	12	12	12	12	12	12	12	12	12	12	12	12	12	12	12	12	12
10	202731	Screw	8	8	8	8	8	8	8	8	8	8	8	8	8	8	8	8	8
11	30327	Column, steering	1	1	1	1	1	1	1	1	1	1	1	1	1	1	1	1	1
12	42232	Washer, lock	4	4	4	4	4	4	4	4	4	4	4	4	4	4	4	4	4
13	63544	Bolt	4	4	4	4	4	4	4	4	4	4	4	4	4	4	4	4	4
14	191613	Steering wheel	1	1	1	1	1	1	1	1	1	1	1	1	1	1	1	1	1
15	803077	Column assembly	1	1	1	1	1	1	1	1	1	1	1	1	1	1	1	1	1
16	202144	Screw	4	4	4	4	4	4	4	4	4	4	4	4	4	4	4	4	4
17	195069	Steering wheel cap	1	1	1	1	1	1	1	1	1	1	1	1	1	1	1	1	1

8 AA 103

STEERING COLUMN ASSEMBLY, 81 & 77 IN. CAB

M30-2	M30-4	M30-2 H	M30-4 H
M40-2	M40-4	M40-2 H	M40-4 H
M50-2	M50-4	M50-2 H	M50-4 H
M60-2	M60-4	M60-2 H	M60-4 H
M30-2 L	M30-4 L	M30-2 H L	M30-4 H L
M40-2 L	M40-4 L	M40-2 H L	M40-4 H L
M50-2 L	M50-4 L	M50-2 H L	M50-4 H L
M60-2 L	M60-4 L	M60-2 H L	M60-4 H L

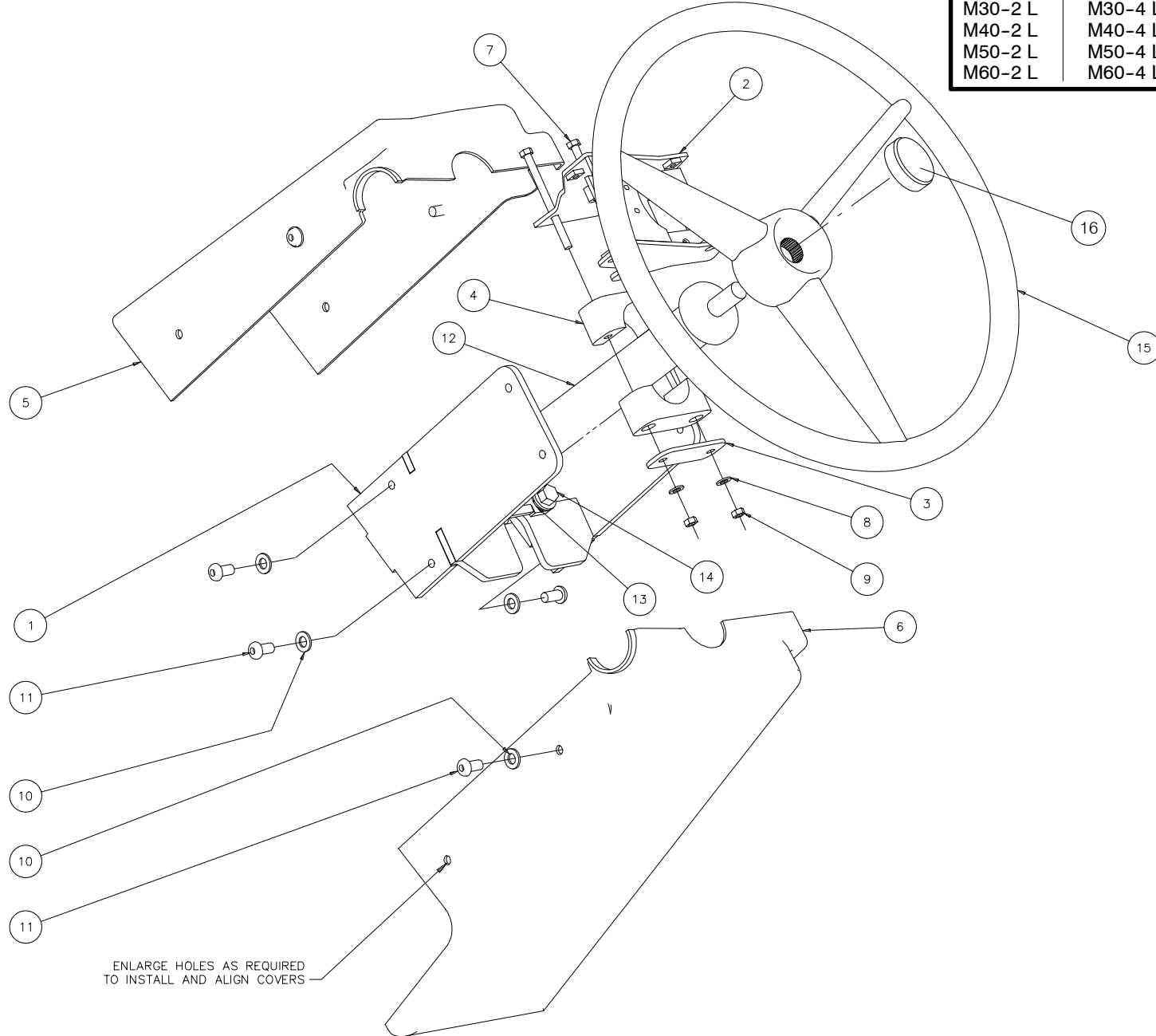

1	QUANTITY / MODEL												8 AA 103					
	M30-4	M40-4	M50-4	M60-4	M30-4 H	M40-4 H	M50-4 H	M60-4 H	M30-4 L	M40-4 L	M50-4 L	M60-4 L	M30-4 H L	M40-4 H L	M50-4 H L	M60-4 H L		
ITEM	PART NO.	DESCRIPTION	M30-2	M40-2	M50-2	M60-2	M30-2 H	M40-2 H	M50-2 H	M60-2 H	M30-2 L	M40-2 L	M50-2 L	M60-2 L	M30-2 H L	M40-2 H L	M50-2 H L	M60-2 H L
1	802025	Steering mount assembly	1	1	1	1	1	1	1	1	1	1	1	1	1	1	1	1
2	203115	Bracket, steering column	1	1	1	1	1	1	1	1	1	1	1	1	1	1	1	1
3	168870	Plate, cover	1	1	1	1	1	1	1	1	1	1	1	1	1	1	1	1
4	174321	Clamp, hose half	2	2	2	2	2	2	2	2	2	2	2	2	2	2	2	2
5	202953	Cover, column front	1	1	1	1	1	1	1	1	1	1	1	1	1	1	1	1
6	202954	Cover, column rear	1	1	1	1	1	1	1	1	1	1	1	1	1	1	1	1
7	165919	Bolt	2	2	2	2	2	2	2	2	2	2	2	2	2	2	2	2
8	29469	Washer, flat	2	2	2	2	2	2	2	2	2	2	2	2	2	2	2	2
9	162229	Nut	2	2	2	2	2	2	2	2	2	2	2	2	2	2	2	2
10	61674	Washer, flat	8	8	8	8	8	8	8	8	8	8	8	8	8	8	8	8
11	202731	Screw	8	8	8	8	8	8	8	8	8	8	8	8	8	8	8	8
12	30327	Column, steering	1	1	1	1	1	1	1	1	1	1	1	1	1	1	1	1
13	42232	Washer, lock	4	4	4	4	4	4	4	4	4	4	4	4	4	4	4	4
14	63544	Bolt	4	4	4	4	4	4	4	4	4	4	4	4	4	4	4	4
15	191613	Steering wheel	1	1	1	1	1	1	1	1	1	1	1	1	1	1	1	1
16	195069	Steering wheel cap	1	1	1	1	1	1	1	1	1	1	1	1	1	1	1	1

8 AA 104

STEERING COLUMN ASSEMBLY, TILTING, 100 IN. SEMI & ENCLOSED CAB

M30-2	M30-4	M30-2 H	M30-4 H
M40-2	M40-4	M40-2 H	M40-4 H
M50-2	M50-4	M50-2 H	M50-4 H
M60-2	M60-4	M60-2 H	M60-4 H
M30-2 L	M30-4 L	M30-2 H L	M30-4 H L
M40-2 L	M40-4 L	M40-2 H L	M40-4 H L
M50-2 L	M50-4 L	M50-2 H L	M50-4 H L
M60-2 L	M60-4 L	M60-2 H L	M60-4 H L

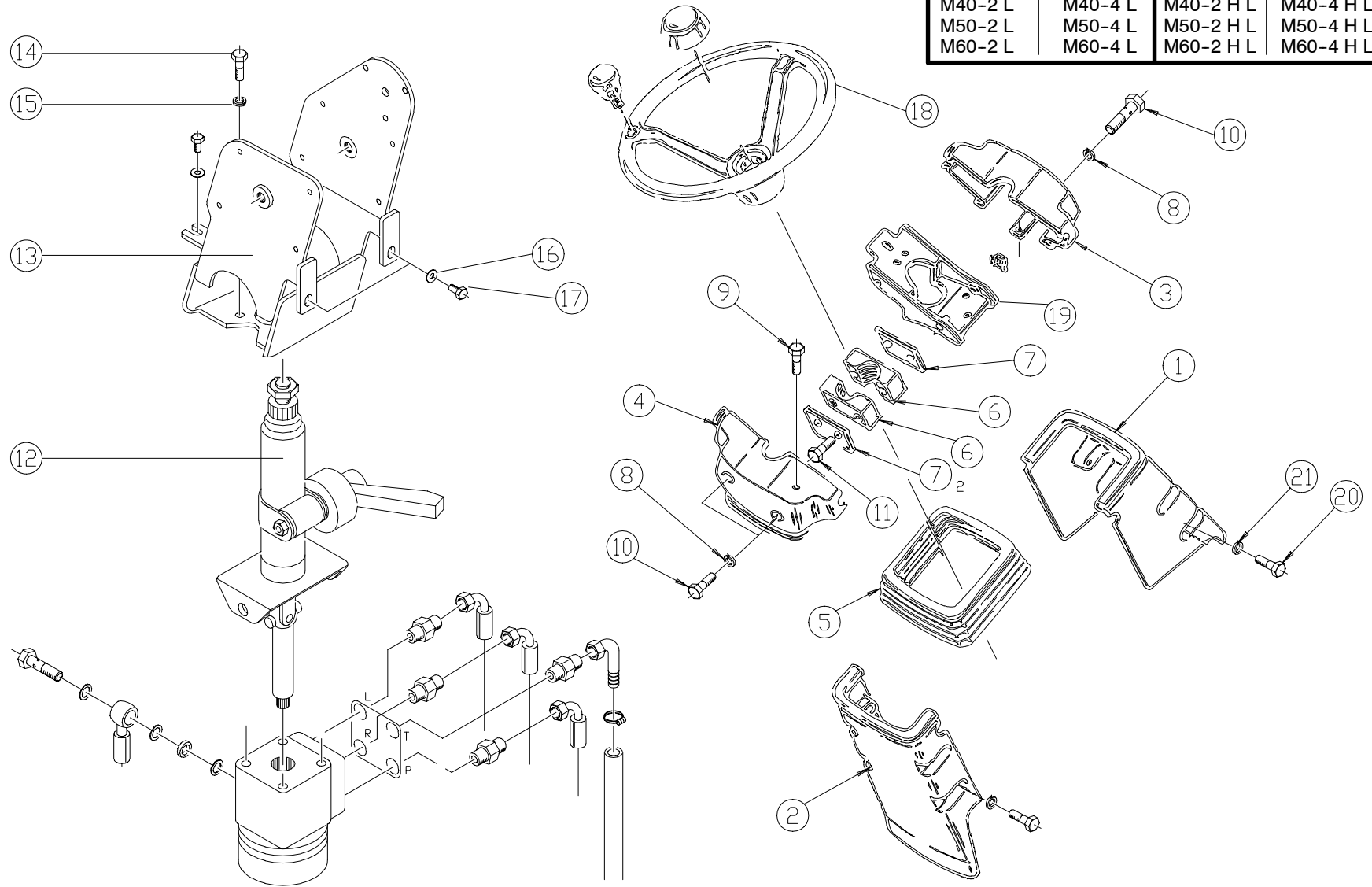

1	STEERING COLUMN ASSEMBLY, TILTING, 100 IN. SEMI & ENCLOSED CAB		QUANTITY / MODEL												8 AA 104			
			M30-4	M40-4	M50-4	M60-4	M30-4 H	M40-4 H	M50-4 H	M60-4 H	M30-4 L	M40-4 L	M50-4 L	M60-4 L	M30-4 H L	M40-4 H L	M50-4 H L	M60-4 H L
ITEM	PART NO.	DESCRIPTION	M30-2	M40-2	M50-2	M60-2	M30-2 H	M40-2 H	M50-2 H	M60-2 H	M30-2 L	M40-2 L	M50-2 L	M60-2 L	M30-2 H L	M40-2 H L	M50-2 H L	M60-2 H L
1	203123	Front cover, lower	1	1	1	1	1	1	1	1	1	1	1	1	1	1	1	1
2	203124	Rear cover, lower	1	1	1	1	1	1	1	1	1	1	1	1	1	1	1	1
3	203125	Front cover, upper	1	1	1	1	1	1	1	1	1	1	1	1	1	1	1	1
4	203126	Rear cover, upper	1	1	1	1	1	1	1	1	1	1	1	1	1	1	1	1
5	203127	Bellow	1	1	1	1	1	1	1	1	1	1	1	1	1	1	1	1
6	173717	Half clamp	2	2	2	2	2	2	2	2	2	2	2	2	2	2	2	2
7	177082	Half clamp plate	5	5	5	5	5	5	5	5	5	5	5	5	5	5	5	5
8	189857	Washer	4	4	4	4	4	4	4	4	4	4	4	4	4	4	4	4
9	78310	Bolt	1	1	1	1	1	1	1	1	1	1	1	1	1	1	1	1
10	196951	Bolt	4	4	4	4	4	4	4	4	4	4	4	4	4	4	4	4
11	205933	Bolt	2	2	2	2	2	2	2	2	2	2	2	2	2	2	2	2
12	201563	Tilt column	1	1	1	1	1	1	1	1	1	1	1	1	1	1	1	1
13	218083	Tilt column bracket	1	1	1	1	1	1	1	1	1	1	1	1	1	1	1	1
14	5804	Bolt	4	4	4	4	4	4	4	4	4	4	4	4	4	4	4	4
15	42232	Washer	4	4	4	4	4	4	4	4	4	4	4	4	4	4	4	4
16	42325	Washer, lock	4	4	4	4	4	4	4	4	4	4	4	4	4	4	4	4
17	42347	Bolt	4	4	4	4	4	4	4	4	4	4	4	4	4	4	4	4
18	191613	Steering wheel	1	1	1	1	1	1	1	1	1	1	1	1	1	1	1	1
19	203115	Bracket	1	1	1	1	1	1	1	1	1	1	1	1	1	1	1	1
20	205275	Screw	4	4	4	4	4	4	4	4	4	4	4	4	4	4	4	4
21	29469	Washer, flat	4	4	4	4	4	4	4	4	4	4	4	4	4	4	4	4

8 AA 105

STEERING COLUMN ASSEMBLY, TILTING, 100 IN. OPEN CAB

M30-2	M30-4	M30-2 H	M30-4 H
M40-2	M40-4	M40-2 H	M40-4 H
M50-2	M50-4	M50-2 H	M50-4 H
M60-2	M60-4	M60-2 H	M60-4 H
M30-2 L	M30-4 L	M30-2 H L	M30-4 H L
M40-2 L	M40-4 L	M40-2 H L	M40-4 H L
M50-2 L	M50-4 L	M50-2 H L	M50-4 H L
M60-2 L	M60-4 L	M60-2 H L	M60-4 H L

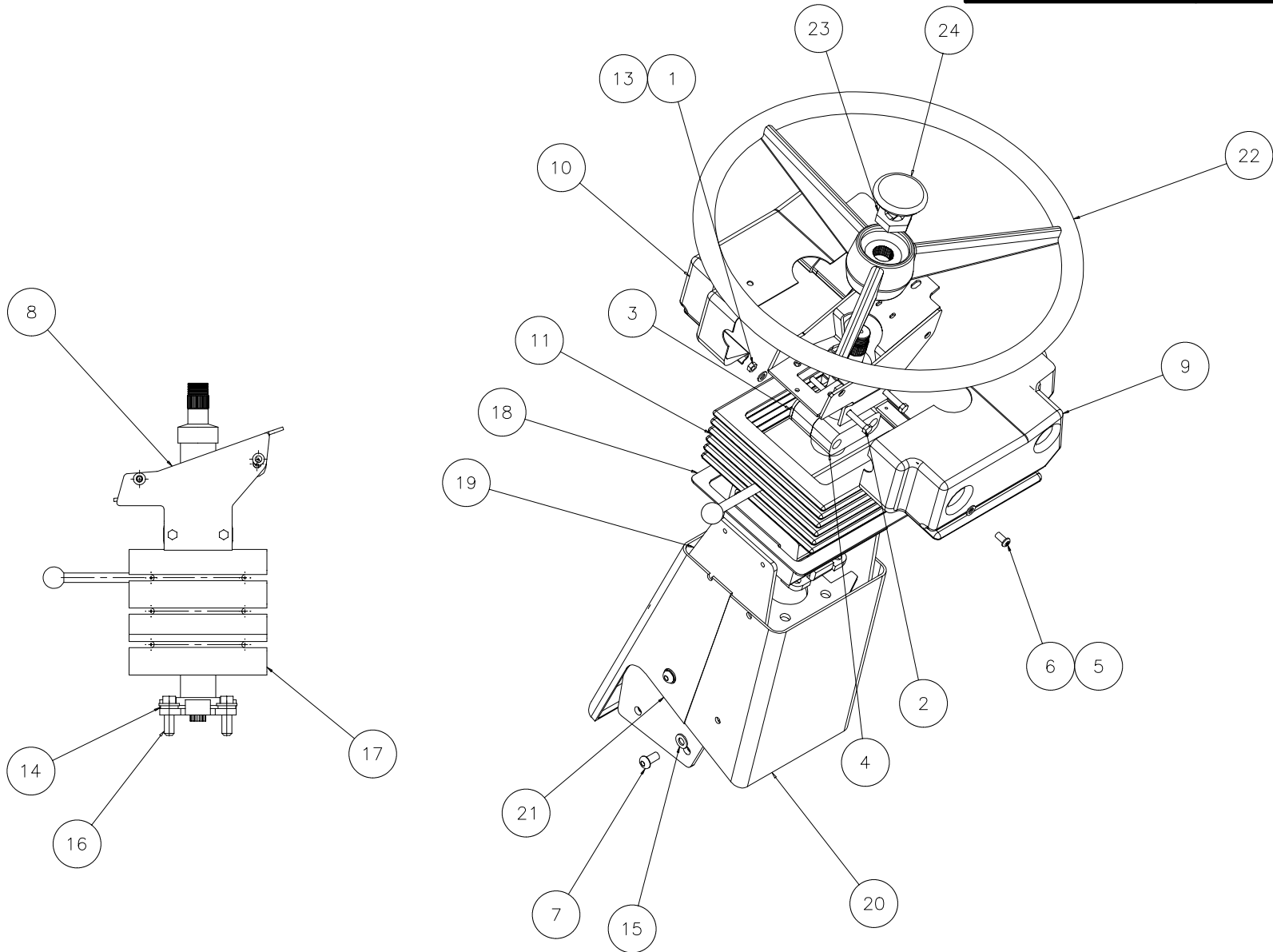

1	STEERING COLUMN ASSEMBLY, TILTING, 100 IN. OPEN CAB		QUANTITY / MODEL												8 AA 105			
			M30-4	M40-4	M50-4	M60-4	M30-4 H	M40-4 H	M50-4 H	M60-4 H	M30-4 L	M40-4 L	M50-4 L	M60-4 L	M30-4 H L	M40-4 H L	M50-4 H L	M60-4 H L
ITEM	PART NO.	DESCRIPTION	M30-2	M40-2	M50-2	M60-2	M30-2 H	M40-2 H	M50-2 H	M60-2 H	M30-2 L	M40-2 L	M50-2 L	M60-2 L	M30-2 H L	M40-2 H L	M50-2 H L	M60-2 H L
1	162229	Nut	2	2	2	2	2	2	2	2	2	2	2	2	2	2	2	2
2	165919	Bolt	2	2	2	2	2	2	2	2	2	2	2	2	2	2	2	2
3	168870	Plate, cover	1	1	1	1	1	1	1	1	1	1	1	1	1	1	1	1
4	174321	Clamp, hose half	2	2	2	2	2	2	2	2	2	2	2	2	2	2	2	2
5	189857	Washer, flat	4	4	4	4	4	4	4	4	4	4	4	4	4	4	4	4
6	196951	Screw	4	4	4	4	4	4	4	4	4	4	4	4	4	4	4	4
7	202731	Screw	4	4	4	4	4	4	4	4	4	4	4	4	4	4	4	4
8	203115	Bracket, steering column	1	1	1	1	1	1	1	1	1	1	1	1	1	1	1	1
9	203125	Housing	1	1	1	1	1	1	1	1	1	1	1	1	1	1	1	1
10	203126	Housing	1	1	1	1	1	1	1	1	1	1	1	1	1	1	1	1
11	203127	Bellows	1	1	1	1	1	1	1	1	1	1	1	1	1	1	1	1
12	25713	Bolt	4	4	4	4	4	4	4	4	4	4	4	4	4	4	4	4
13	29469	Washer, flat	6	6	6	6	6	6	6	6	6	6	6	6	6	6	6	6
14	42232	Washer, lock	4	4	4	4	4	4	4	4	4	4	4	4	4	4	4	4
15	61674	Washer, flat	4	4	4	4	4	4	4	4	4	4	4	4	4	4	4	4
16	63544	Bolt	4	4	4	4	4	4	4	4	4	4	4	4	4	4	4	4
17	803103	Column, tilt	1	1	1	1	1	1	1	1	1	1	1	1	1	1	1	1
18	803112	Bracket	1	1	1	1	1	1	1	1	1	1	1	1	1	1	1	1
19	803136	Column bracket	1	1	1	1	1	1	1	1	1	1	1	1	1	1	1	1
20	803146	Cover, front column	1	1	1	1	1	1	1	1	1	1	1	1	1	1	1	1
21	803147	Cover, rear column	1	1	1	1	1	1	1	1	1	1	1	1	1	1	1	1
22	B1828	Wheel, steering	1	1	1	1	1	1	1	1	1	1	1	1	1	1	1	1
23	B1829	Nut	1	1	1	1	1	1	1	1	1	1	1	1	1	1	1	1
24	B2007	Closure	1	1	1	1	1	1	1	1	1	1	1	1	1	1	1	1

8 AA 106

STEERING COLUMN ASSEMBLY, TILTING, 81 & 77 IN. OPEN CAB

M30-2	M30-4	M30-2 H	M30-4 H
M40-2	M40-4	M40-2 H	M40-4 H
M50-2	M50-4	M50-2 H	M50-4 H
M60-2	M60-4	M60-2 H	M60-4 H
M30-2 L	M30-4 L	M30-2 H L	M30-4 H L
M40-2 L	M40-4 L	M40-2 H L	M40-4 H L
M50-2 L	M50-4 L	M50-2 H L	M50-4 H L
M60-2 L	M60-4 L	M60-2 H L	M60-4 H L

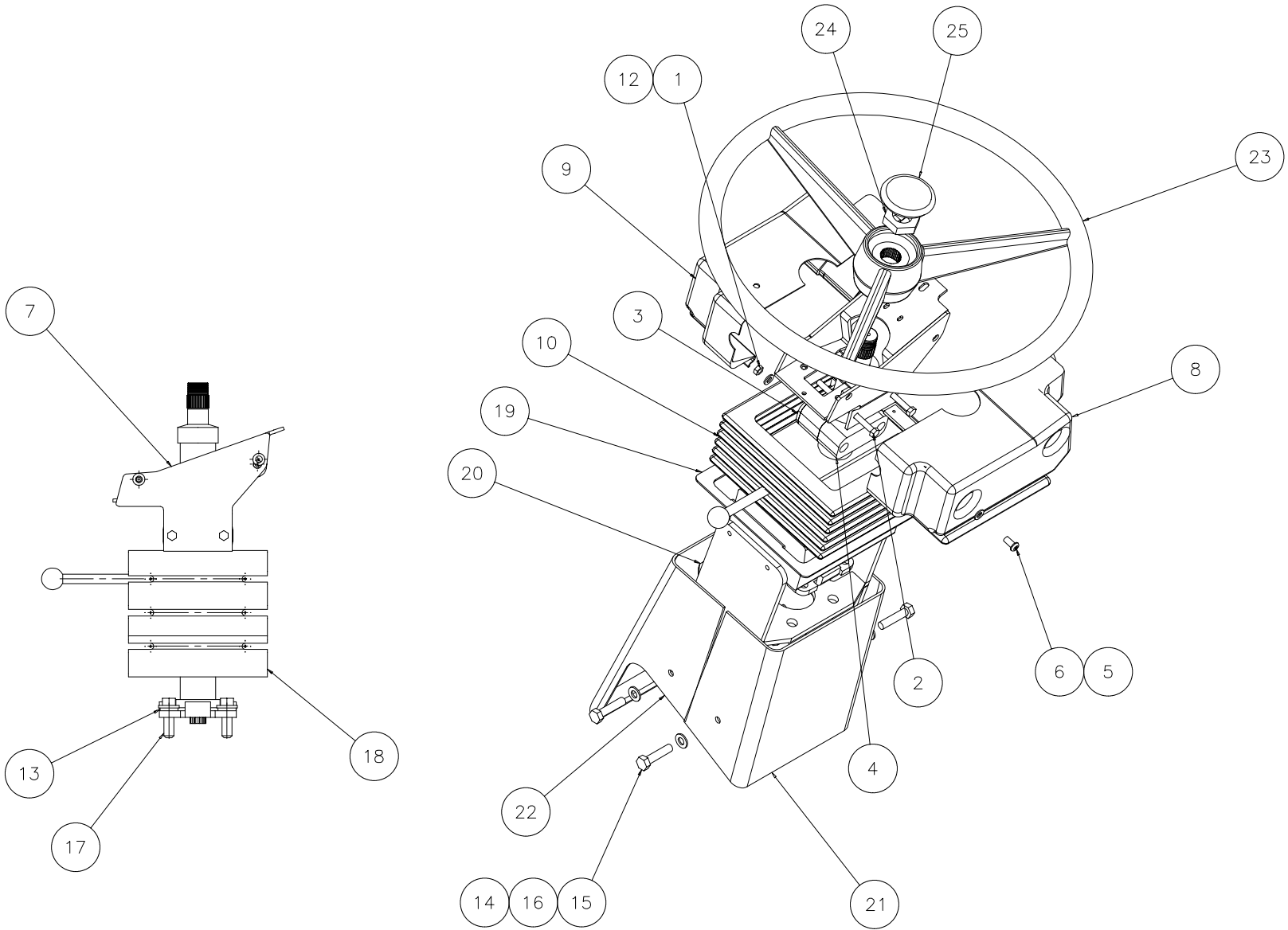

1	STEERING COLUMN ASSEMBLY, TILTING, 81 & 77 IN. OPEN CAB		QUANTITY / MODEL												8 AA 106			
			M30-4	M40-4	M50-4	M60-4	M30-4 H	M40-4 H	M50-4 H	M60-4 H	M30-4 L	M40-4 L	M50-4 L	M60-4 L	M30-4 H L	M40-4 H L	M50-4 H L	M60-4 H L
ITEM	PART NO.	DESCRIPTION	M30-2	M40-2	M50-2	M60-2	M30-2 H	M40-2 H	M50-2 H	M60-2 H	M30-2 L	M40-2 L	M50-2 L	M60-2 L	M30-2 H L	M40-2 H L	M50-2 H L	M60-2 H L
1	162229	Nut	2	2	2	2	2	2	2	2	2	2	2	2	2	2	2	2
2	165919	Bolt	2	2	2	2	2	2	2	2	2	2	2	2	2	2	2	2
3	168870	Plate, cover	1	1	1	1	1	1	1	1	1	1	1	1	1	1	1	1
4	174321	Clamp, hose half	2	2	2	2	2	2	2	2	2	2	2	2	2	2	2	2
5	189857	Washer, flat	4	4	4	4	4	4	4	4	4	4	4	4	4	4	4	4
6	196951	Screw	4	4	4	4	4	4	4	4	4	4	4	4	4	4	4	4
7	203115	Bracket, steering column	1	1	1	1	1	1	1	1	1	1	1	1	1	1	1	1
8	203125	Housing	1	1	1	1	1	1	1	1	1	1	1	1	1	1	1	1
9	203126	Housing	1	1	1	1	1	1	1	1	1	1	1	1	1	1	1	1
10	203127	Bellows	1	1	1	1	1	1	1	1	1	1	1	1	1	1	1	1
11	25713	Bolt	4	4	4	4	4	4	4	4	4	4	4	4	4	4	4	4
12	29469	Washer, flat	6	6	6	6	6	6	6	6	6	6	6	6	6	6	6	6
13	42232	Washer, lock	4	4	4	4	4	4	4	4	4	4	4	4	4	4	4	4
14	58528	Nut	4	4	4	4	4	4	4	4	4	4	4	4	4	4	4	4
15	61323	Bolt	4	4	4	4	4	4	4	4	4	4	4	4	4	4	4	4
16	61674	Washer, flat	4	4	4	4	4	4	4	4	4	4	4	4	4	4	4	4
17	63544	Bolt	4	4	4	4	4	4	4	4	4	4	4	4	4	4	4	4
18	803103	Column, tilt	1	1	1	1	1	1	1	1	1	1	1	1	1	1	1	1
19	803112	Bracket	1	1	1	1	1	1	1	1	1	1	1	1	1	1	1	1
20	803120	Steering mount assembly	1	1	1	1	1	1	1	1	1	1	1	1	1	1	1	1
21	803128	Cover, front column	1	1	1	1	1	1	1	1	1	1	1	1	1	1	1	1
22	803129	Cover, rear column	1	1	1	1	1	1	1	1	1	1	1	1	1	1	1	1
23	B1828	Wheel, steering	1	1	1	1	1	1	1	1	1	1	1	1	1	1	1	1
24	B1829	Nut	1	1	1	1	1	1	1	1	1	1	1	1	1	1	1	1
25	B2007	Closure	1	1	1	1	1	1	1	1	1	1	1	1	1	1	1	1

8 AA 110

SEAT ASSEMBLY, 100 IN. CAB

M30-2	M30-4	M30-2 H	M30-4 H
M40-2	M40-4	M40-2 H	M40-4 H
M50-2	M50-4	M50-2 H	M50-4 H
M60-2	M60-4	M60-2 H	M60-4 H
M30-2 L	M30-4 L	M30-2 H L	M30-4 H L
M40-2 L	M40-4 L	M40-2 H L	M40-4 H L
M50-2 L	M50-4 L	M50-2 H L	M50-4 H L
M60-2 L	M60-4 L	M60-2 H L	M60-4 H L

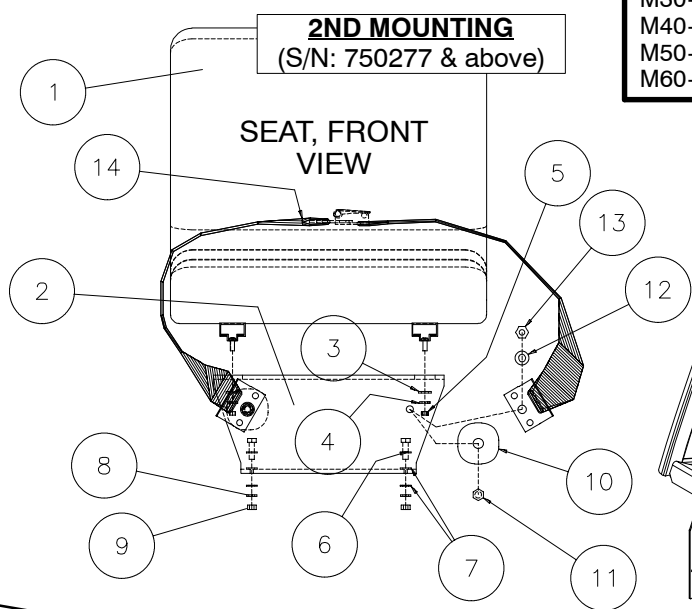
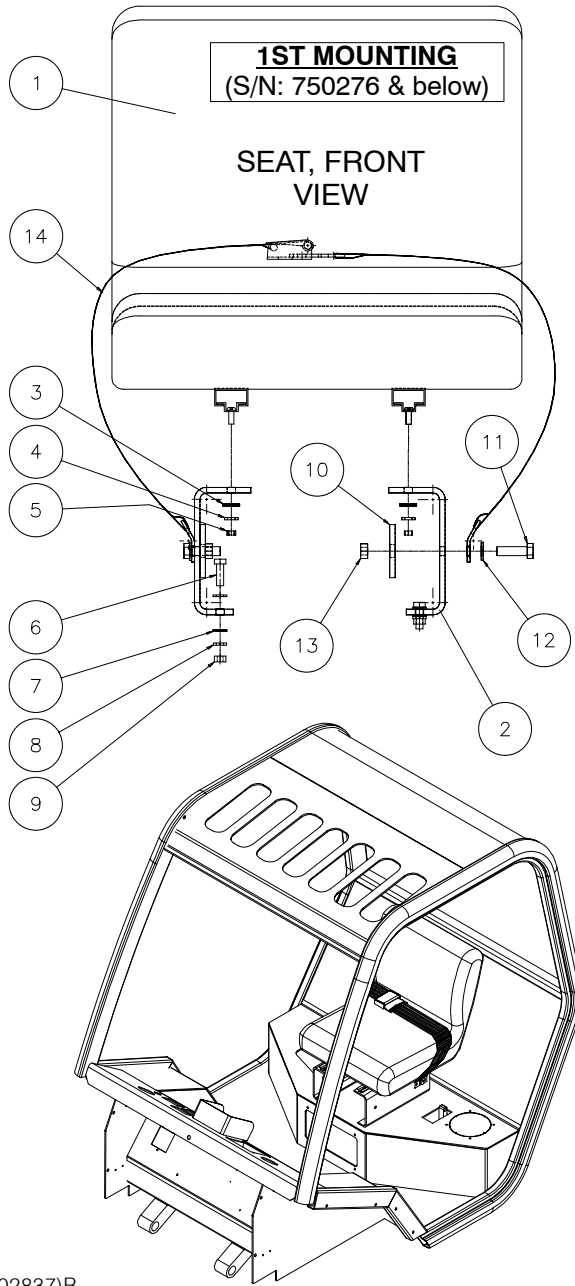

OPTIONAL SUSPENSION SEAT

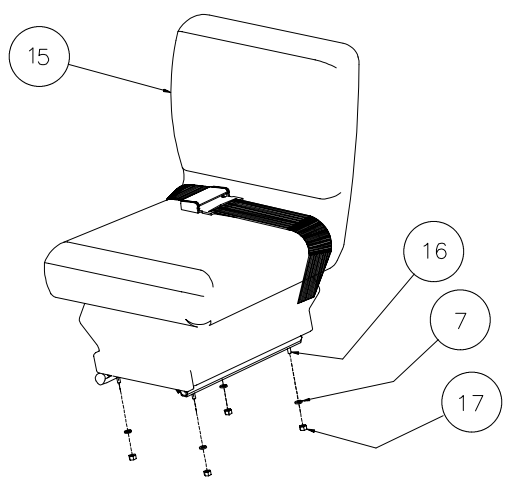

1	SEAT ASSEMBLY, 100 IN. CAB												8 AA 110					
	ITEM	PART NO.	DESCRIPTION	QUANTITY / MODEL														
				M30-2	M40-2	M50-2	M60-2	M30-2 H	M40-2 H	M50-2 H	M60-2 H	M30-2 L	M40-2 L	M50-2 L	M60-2 L	M30-2 H L	M40-2 H L	M50-2 H L
1	491746	Seat assembly w/ rails	1	1	1	1	1	1	1	1	1	1	1	1	1	1	1	1
2A	802836	Pedestal, seat - S/N: 750276 & below	2	2	2	2	2	2	2	2	2	2	2	2	2	2	2	2
2B	803986	Pedestal, seat - S/N: 750277 & above	2	2	2	2	2	2	2	2	2	2	2	2	2	2	2	2
3	K44877	Washer, flat	4	4	4	4	4	4	4	4	4	4	4	4	4	4	4	4
4	K34791	Washer, lock	4	4	4	4	4	4	4	4	4	4	4	4	4	4	4	4
5	K33770	Nut	4	4	4	4	4	4	4	4	4	4	4	4	4	4	4	4
6	57446	Bolt	4	4	4	4	4	4	4	4	4	4	4	4	4	4	4	4
7	61674	Washer, flat	A/R	A/R	A/R	A/R	A/R	A/R	A/R	A/R	A/R	A/R	A/R	A/R	A/R	A/R	A/R	A/R
8	42325	Washer, lock	4	4	4	4	4	4	4	4	4	4	4	4	4	4	4	4
9	58528	Nut	4	4	4	4	4	4	4	4	4	4	4	4	4	4	4	4
10	802082	Plate, washer	2	2	2	2	2	2	2	2	2	2	2	2	2	2	2	2
11	168351	Bolt	2	2	2	2	2	2	2	2	2	2	2	2	2	2	2	2
12	29437	Washer, flat	2	2	2	2	2	2	2	2	2	2	2	2	2	2	2	2
13	56354	Nut	2	2	2	2	2	2	2	2	2	2	2	2	2	2	2	2
14	495931	Seat belt, 3 in.	1	1	1	1	1	1	1	1	1	1	1	1	1	1	1	1
15	191022	Seat, suspension	1	1	1	1	1	1	1	1	1	1	1	1	1	1	1	1
16	42347	Bolt	4	4	4	4	4	4	4	4	4	4	4	4	4	4	4	4
17	54242	Nut	4	4	4	4	4	4	4	4	4	4	4	4	4	4	4	4

8 AA 111

SEAT ASSEMBLY, LOW BACK, 77 & 81 IN. CAB

M30-2	M30-4	M30-2 H	M30-4 H
M40-2	M40-4	M40-2 H	M40-4 H
M50-2	M50-4	M50-2 H	M50-4 H
M60-2	M60-4	M60-2 H	M60-4 H
M30-2 L	M30-4 L	M30-2 H L	M30-4 H L
M40-2 L	M40-4 L	M40-2 H L	M40-4 H L
M50-2 L	M50-4 L	M50-2 H L	M50-4 H L
M60-2 L	M60-4 L	M60-2 H L	M60-4 H L

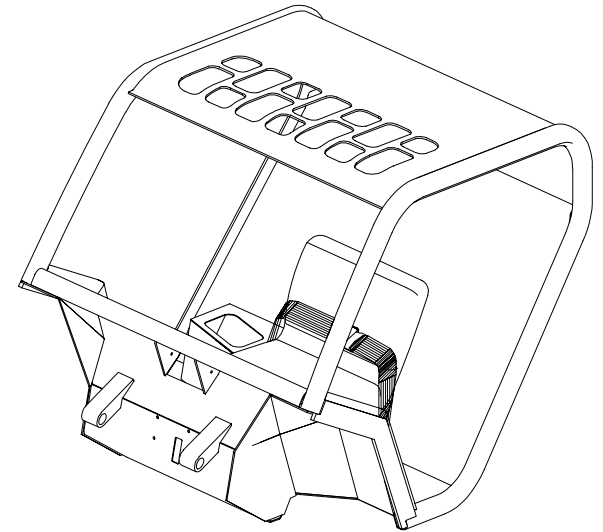
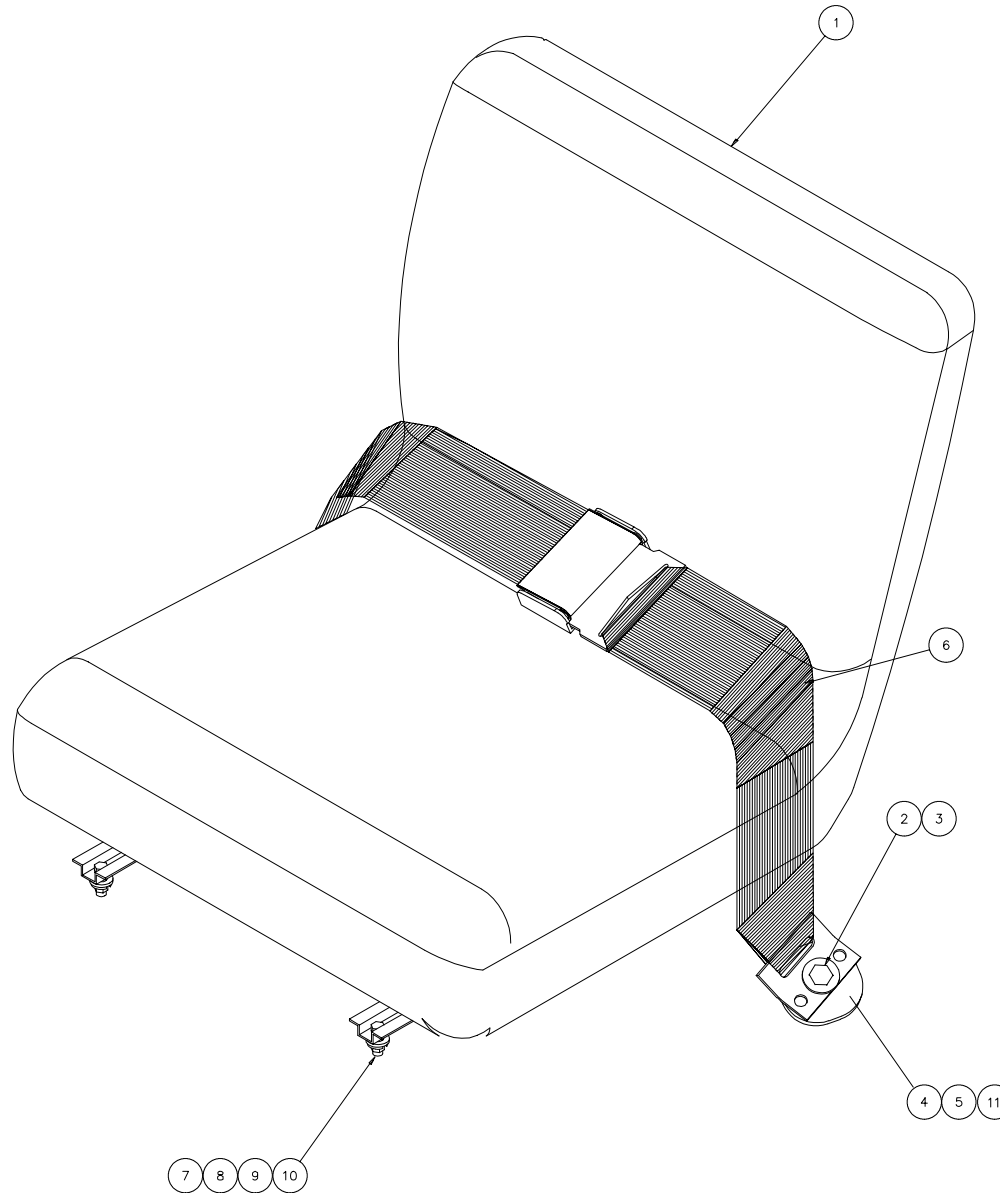

1	SEAT ASSEMBLY, LOW BACK, 77 & 81 IN. CAB												8 AA 111						
	ITEM	PART NO.	DESCRIPTION	M30-2	M40-2	M50-2	M60-2	M30-2 H	M40-2 H	M50-2 H	M60-2 H	M30-2 L	M40-2 L	M50-2 L	M60-2 L	M30-2 H L	M40-2 H L	M50-2 H L	M60-2 H L
1	801623	Seat, 17.5 in. height	1	1	1	1	1	1	1	1	1	1	1	1	1	1	1	1	1
2	KN605803	Bolt	2	2	2	2	2	2	2	2	2	2	2	2	2	2	2	2	2
3	29437	Washer, flat	2	2	2	2	2	2	2	2	2	2	2	2	2	2	2	2	2
4	802082	Plate, washer	2	2	2	2	2	2	2	2	2	2	2	2	2	2	2	2	2
5	56354	Nut	2	2	2	2	2	2	2	2	2	2	2	2	2	2	2	2	2
6	495931	Seat belt, 3 in.	1	1	1	1	1	1	1	1	1	1	1	1	1	1	1	1	1
7	42347	Bolt	4	4	4	4	4	4	4	4	4	4	4	4	4	4	4	4	4
8	61674	Washer, flat	4	4	4	4	4	4	4	4	4	4	4	4	4	4	4	4	4
9	42325	Washer, lock	4	4	4	4	4	4	4	4	4	4	4	4	4	4	4	4	4
10	58528	Nut	4	4	4	4	4	4	4	4	4	4	4	4	4	4	4	4	4
11	42232	Washer, lock	2	2	2	2	2	2	2	2	2	2	2	2	2	2	2	2	2

8 AA 112

SEAT ASSEMBLY, HIGH BACK, 77 & 81 IN. CAB

M30-2	M30-4	M30-2 H	M30-4 H
M40-2	M40-4	M40-2 H	M40-4 H
M50-2	M50-4	M50-2 H	M50-4 H
M60-2	M60-4	M60-2 H	M60-4 H
M30-2 L	M30-4 L	M30-2 H L	M30-4 H L
M40-2 L	M40-4 L	M40-2 H L	M40-4 H L
M50-2 L	M50-4 L	M50-2 H L	M50-4 H L
M60-2 L	M60-4 L	M60-2 H L	M60-4 H L

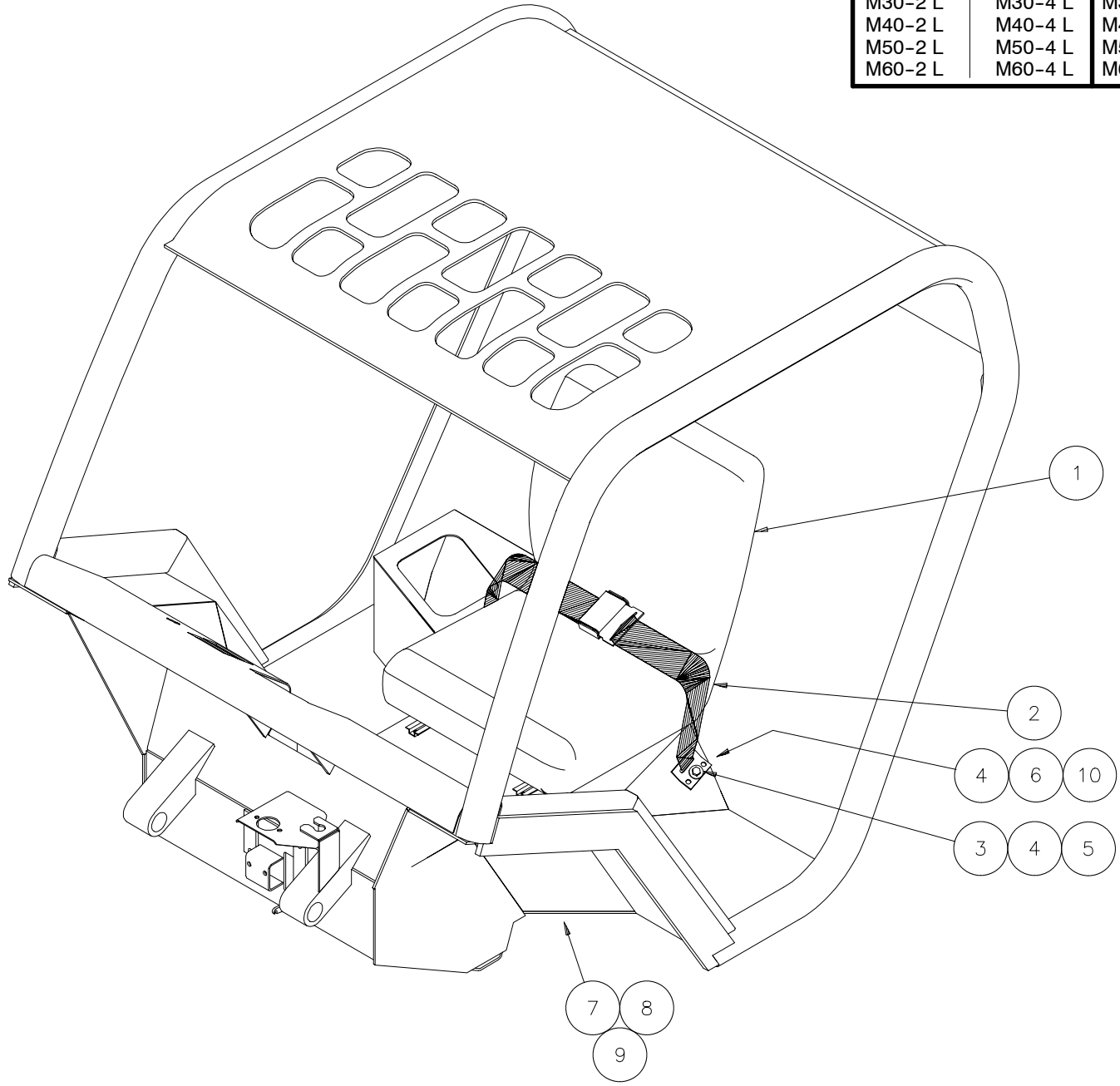

1	SEAT ASSEMBLY, HIGH BACK, 77 & 81 IN. CAB												8 AA 112						
	ITEM	PART NO.	DESCRIPTION	M30-2	M40-2	M50-2	M60-2	M30-2 H	M40-2 H	M50-2 H	M60-2 H	M30-2 L	M40-2 L	M50-2 L	M60-2 L	M30-2 H L	M40-2 H L	M50-2 H L	M60-2 H L
1	491746	Seat, hight back, 21.75 height	1	1	1	1	1	1	1	1	1	1	1	1	1	1	1	1	1
2	495931	Seat belt, 3 in.	1	1	1	1	1	1	1	1	1	1	1	1	1	1	1	1	1
3	168351	Bolt	2	2	2	2	2	2	2	2	2	2	2	2	2	2	2	2	2
4	29437	Washer, flat	2	2	2	2	2	2	2	2	2	2	2	2	2	2	2	2	2
5	802082	Plate, washer	2	2	2	2	2	2	2	2	2	2	2	2	2	2	2	2	2
6	56354	Nut	2	2	2	2	2	2	2	2	2	2	2	2	2	2	2	2	2
7	K44877	Washer, flat	4	4	4	4	4	4	4	4	4	4	4	4	4	4	4	4	4
8	K34791	Washer, lock	4	4	4	4	4	4	4	4	4	4	4	4	4	4	4	4	4
9	K33770	Nut	4	4	4	4	4	4	4	4	4	4	4	4	4	4	4	4	4
10	42232	Washer, lock	2	2	2	2	2	2	2	2	2	2	2	2	2	2	2	2	2

8 AA 120

FRONT FENDERS, 100 IN. CAB

M30-2	M30-4	M30-2 H	M30-4 H
M40-2	M40-4	M40-2 H	M40-4 H
M50-2	M50-4	M50-2 H	M50-4 H
M60-2	M60-4	M60-2 H	M60-4 H
M30-2 L	M30-4 L	M30-2 H L	M30-4 H L
M40-2 L	M40-4 L	M40-2 H L	M40-4 H L
M50-2 L	M50-4 L	M50-2 H L	M50-4 H L
M60-2 L	M60-4 L	M60-2 H L	M60-4 H L

1ST MOUNTING
(S/N: 750156 & below)

2ND MOUNTING
(S/N: 750157 & above)

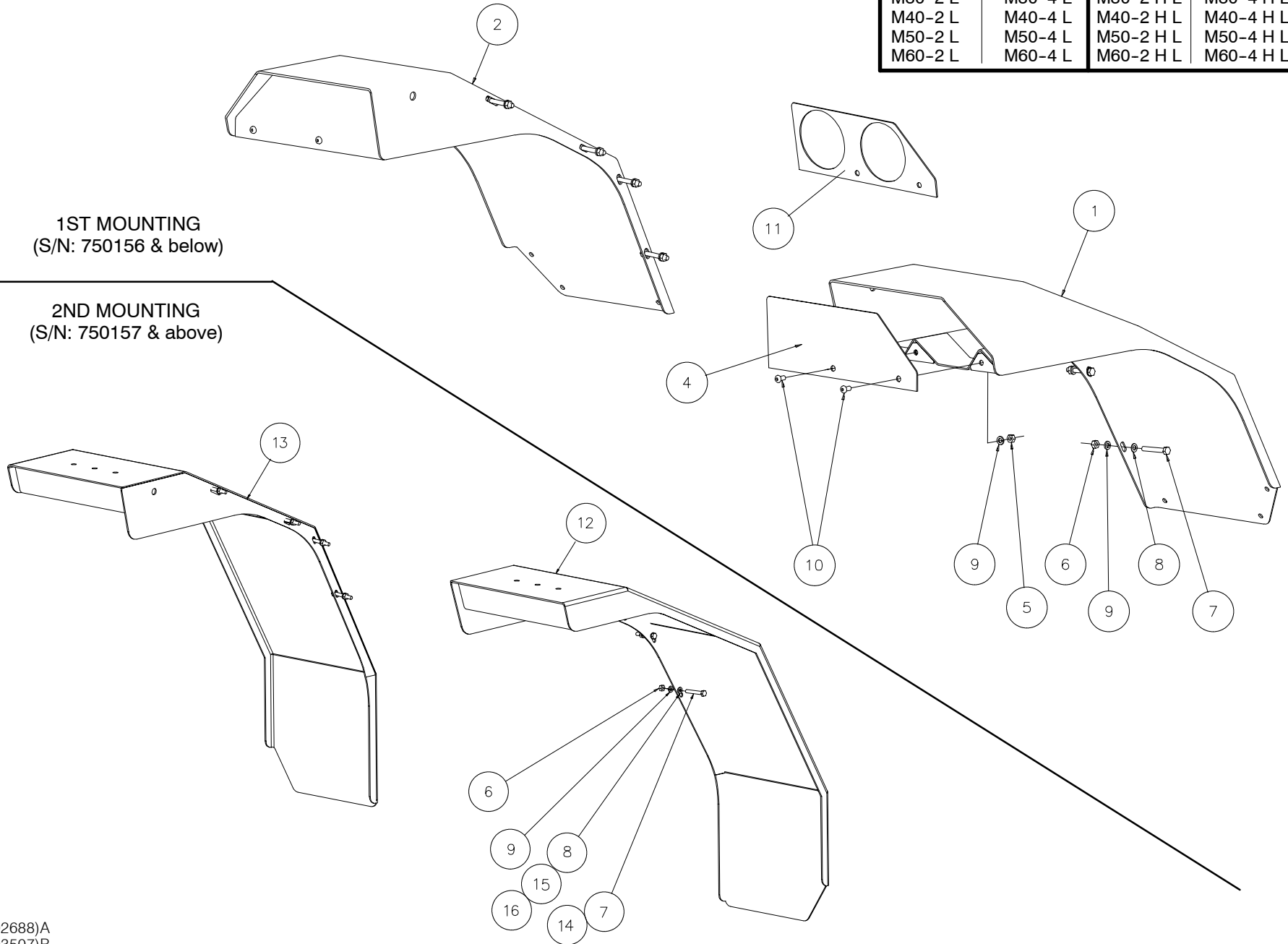

1	FRONT FENDERS, 100 IN. CAB													8 AA 120					
	ITEM	PART NO.	DESCRIPTION	M30-2	M40-2	M50-2	M60-2	M30-2 H	M40-2 H	M50-2 H	M60-2 H	M30-2 L	M40-2 L	M50-2 L	M60-2 L	M30-4 H L	M40-4 H L	M50-4 H L	M60-4 H L
1	802684	Fender assembly, front LH	1	1	1	1	1	1	1	1	1	1	1	1	1	1	1	1	1
2	802685	Fender assembly, front RH	1	1	1	1	1	1	1	1	1	1	1	1	1	1	1	1	1
4	802650	Plate, cover	2	2	2	2	2	2	2	2	2	2	2	2	2	2	2	2	2
5	58528	Nut	4	4	4	4	4	4	4	4	4	4	4	4	4	4	4	4	4
6*	54242	Nut	8	8	8	8	8	8	8	8	8	8	8	8	8	8	8	8	8
7*	61545	Bolt	8	8	8	8	8	8	8	8	8	8	8	8	8	8	8	8	8
8*	61674	Washer, flat	8	8	8	8	8	8	8	8	8	8	8	8	8	8	8	8	8
9*	42325	Washer, lock	12	12	12	12	12	12	12	12	12	12	12	12	12	12	12	12	12
10	202731	Screw	4	4	4	4	4	4	4	4	4	4	4	4	4	4	4	4	4
11	802649	Plate, face	2	2	2	2	2	2	2	2	2	2	2	2	2	2	2	2	2
12	803499	Fender assembly, front LH	1	1	1	1	1	1	1	1	1	1	1	1	1	1	1	1	1
13	803506	Fender assembly, front RH	1	1	1	1	1	1	1	1	1	1	1	1	1	1	1	1	1
14**	63727	Bolt	8	8	8	8	8	8	8	8	8	8	8	8	8	8	8	8	8
15**	42232	Washer, lock	8	8	8	8	8	8	8	8	8	8	8	8	8	8	8	8	8
16**	29437	Washer, flat	8	8	8	8	8	8	8	8	8	8	8	8	8	8	8	8	8

* Hardware for fenders attached through cab frame.

** Hardware for fenders attached to cab frame threaded holes.

8 AA 121

FRONT FENDER EXTENSIONS, 100 IN. CAB

M30-2	M30-4	M30-2 H	M30-4 H
M40-2	M40-4	M40-2 H	M40-4 H
M50-2	M50-4	M50-2 H	M50-4 H
M60-2	M60-4	M60-2 H	M60-4 H
M30-2 L	M30-4 L	M30-2 H L	M30-4 H L
M40-2 L	M40-4 L	M40-2 H L	M40-4 H L
M50-2 L	M50-4 L	M50-2 H L	M50-4 H L
M60-2 L	M60-4 L	M60-2 H L	M60-4 H L

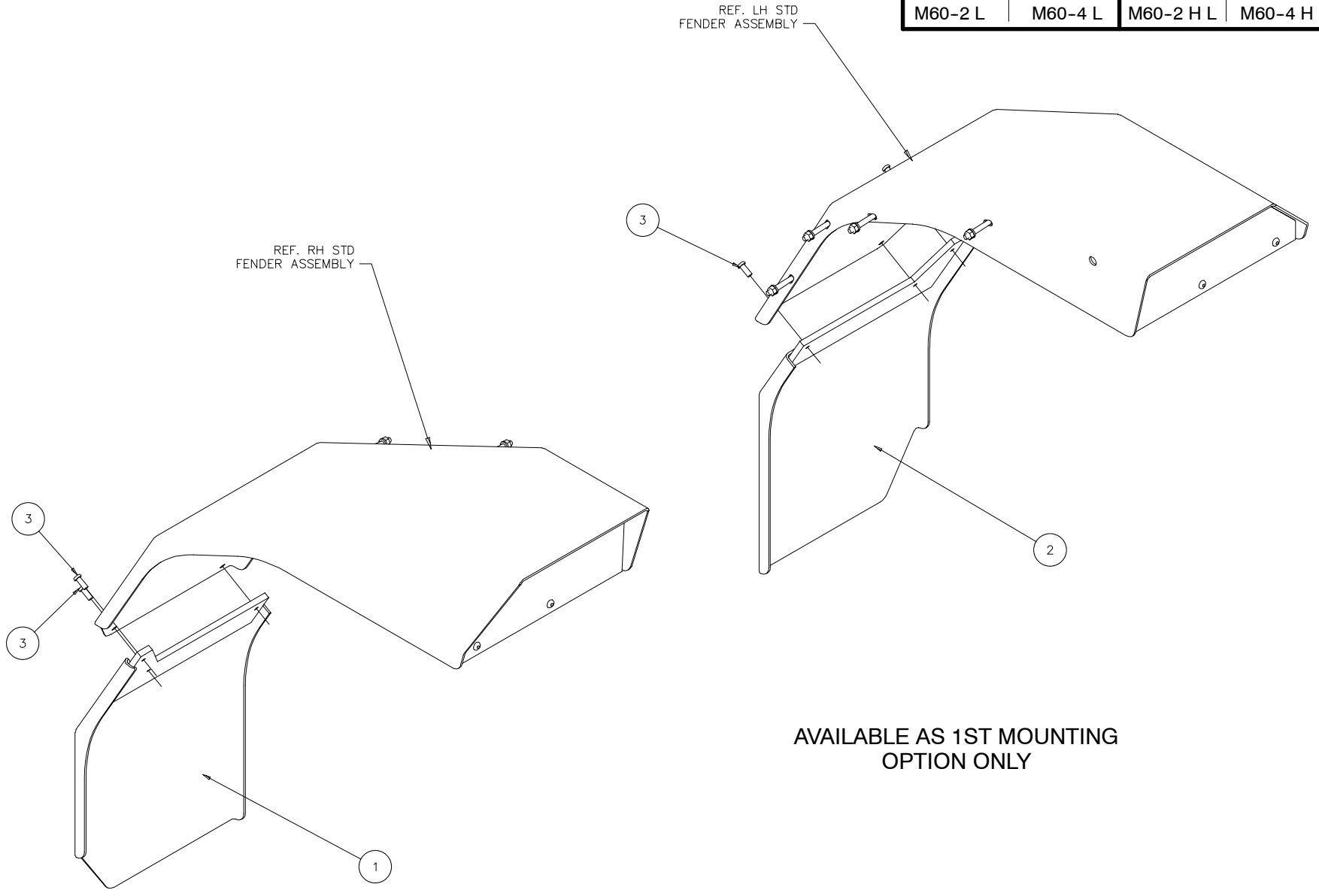

AVAILABLE AS 1ST MOUNTING
OPTION ONLY

ITEM	PART NO.	DESCRIPTION	QUANTITY / MODEL												8 AA 121			
			M30-2	M40-2	M50-2	M60-2	M30-2 H	M40-2 H	M50-2 H	M60-2 H	M30-2 L	M40-2 L	M50-2 L	M60-2 L	M30-4 H L	M40-4 H L	M50-4 H L	M60-4 H L
1		FRONT FENDER EXTENSIONS, 100 IN. CAB																
1	802696	Fender extension, RH	1	1	1	1	1	1	1	1	1	1	1	1	1	1	1	1
2	802695	Fender extension, LH	1	1	1	1	1	1	1	1	1	1	1	1	1	1	1	1
3	202144	Screw	6	6	6	6	6	6	6	6	6	6	6	6	6	6	6	6

8 AA 122

FRONT FENDERS, 81 & 77 IN. CABS

M30-2	M30-4	M30-2 H	M30-4 H
M40-2	M40-4	M40-2 H	M40-4 H
M50-2	M50-4	M50-2 H	M50-4 H
M60-2	M60-4	M60-2 H	M60-4 H
M30-2 L	M30-4 L	M30-2 H L	M30-4 H L
M40-2 L	M40-4 L	M40-2 H L	M40-4 H L
M50-2 L	M50-4 L	M50-2 H L	M50-4 H L
M60-2 L	M60-4 L	M60-2 H L	M60-4 H L

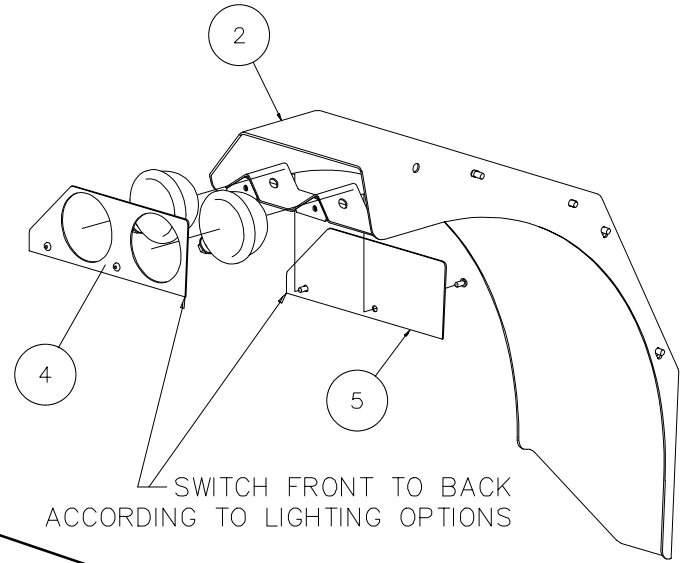

1ST MOUNTING
(S/N: 750152 & below)

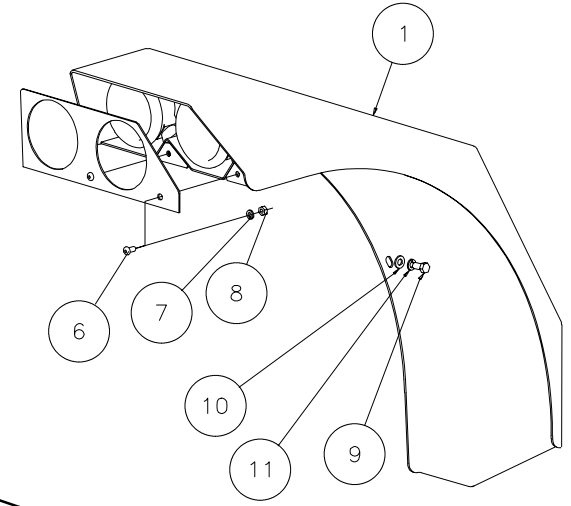

2ND MOUNTING
(S/N: 750153 & above)

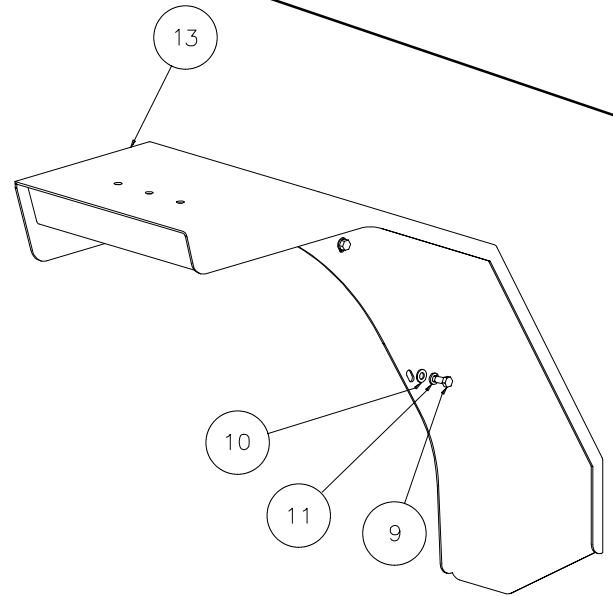
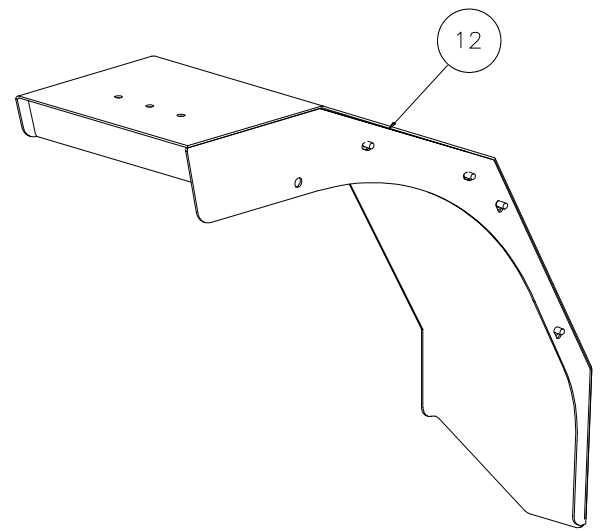

1	FRONT FENDERS, 81 & 77 IN. CABS													8 AA 122					
	ITEM	PART NO.	DESCRIPTION	M30-2	M40-2	M50-2	M60-2	M30-2 H	M40-2 H	M50-2 H	M60-2 H	M30-2 L	M40-2 L	M50-2 L	M60-2 L	M30-4 H L	M40-4 H L	M50-4 H L	M60-4 H L
1	802643	Fender, front LH	1	1	1	1	1	1	1	1	1	1	1	1	1	1	1	1	1
2	802645	Fender, front RH	1	1	1	1	1	1	1	1	1	1	1	1	1	1	1	1	1
4	802649	Plate, face	2	2	2	2	2	2	2	2	2	2	2	2	2	2	2	2	2
5	802650	Plate, cover	2	2	2	2	2	2	2	2	2	2	2	2	2	2	2	2	2
6	202731	Screw	8	8	8	8	8	8	8	8	8	8	8	8	8	8	8	8	8
7	42325	Washer, lock	8	8	8	8	8	8	8	8	8	8	8	8	8	8	8	8	8
8	58528	Nut	8	8	8	8	8	8	8	8	8	8	8	8	8	8	8	8	8
9	63727	Bolt	A/R	A/R	A/R	A/R	A/R	A/R	A/R	A/R	A/R	A/R	A/R	A/R	A/R	A/R	A/R	A/R	A/R
10	29437	Washer, flat	A/R	A/R	A/R	A/R	A/R	A/R	A/R	A/R	A/R	A/R	A/R	A/R	A/R	A/R	A/R	A/R	A/R
11	42232	Washer, lock	A/R	A/R	A/R	A/R	A/R	A/R	A/R	A/R	A/R	A/R	A/R	A/R	A/R	A/R	A/R	A/R	A/R
12	803458	Fender, front RH	1	1	1	1	1	1	1	1	1	1	1	1	1	1	1	1	1
13	803461	Fender, front LH	1	1	1	1	1	1	1	1	1	1	1	1	1	1	1	1	1

8 AA 123

WINDSHIELD KIT, 100 IN. OPEN CAB (CAB 802656)

M30-2	M30-4	M30-2 H	M30-4 H
M40-2	M40-4	M40-2 H	M40-4 H
M50-2	M50-4	M50-2 H	M50-4 H
M60-2	M60-4	M60-2 H	M60-4 H
M30-2 L	M30-4 L	M30-2 H L	M30-4 H L
M40-2 L	M40-4 L	M40-2 H L	M40-4 H L
M50-2 L	M50-4 L	M50-2 H L	M50-4 H L
M60-2 L	M60-4 L	M60-2 H L	M60-4 H L

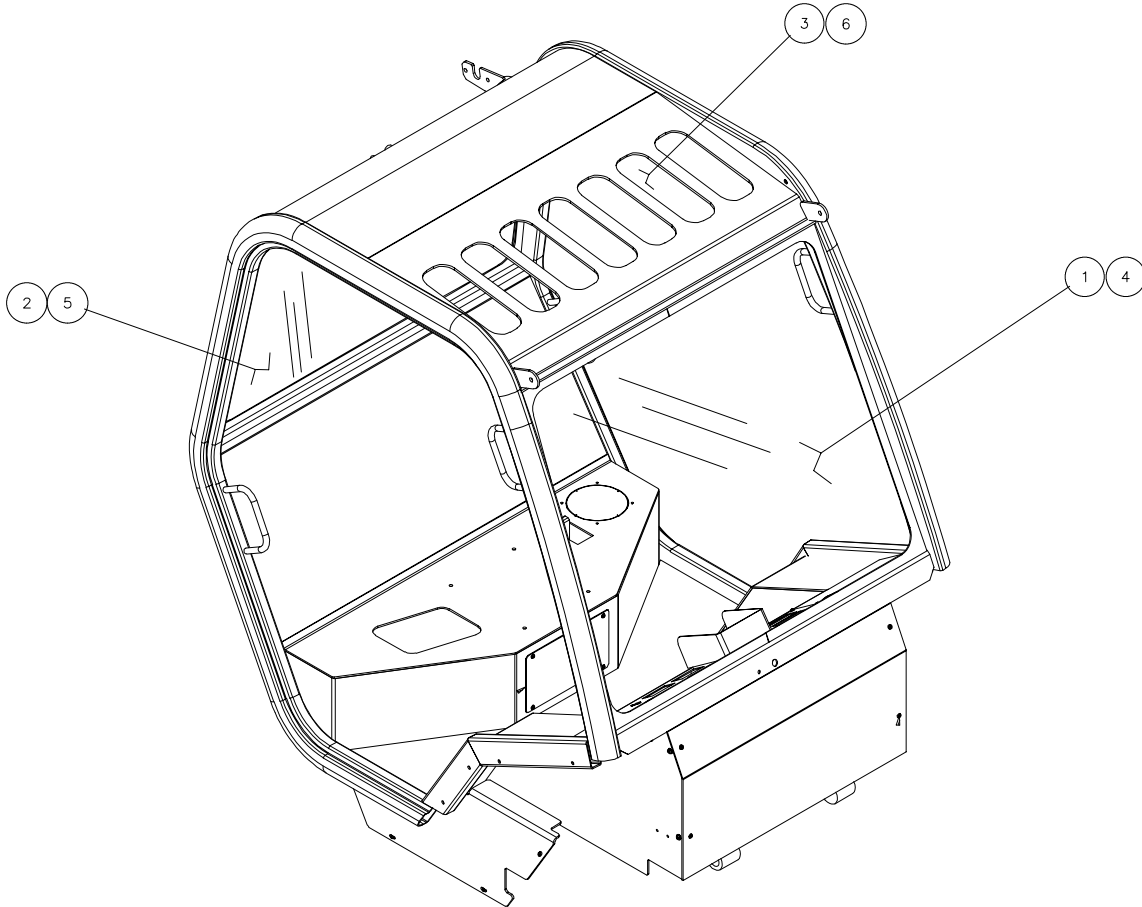

INSTALL TRIM-LOCK (ITEM 6) WITH BLACK URETHANE WINDSHIELD ADHESIVE.

ITEM	PART NO.	DESCRIPTION	QUANTITY / MODEL												8 AA 123			
			M30-2	M40-2	M50-2	M60-2	M30-2 H	M40-2 H	M50-2 H	M60-2 H	M30-2 L	M40-2 L	M50-2 L	M60-2 L	M30-2 H L	M40-2 H L	M50-2 H L	M60-2 H L
1	803139	Windshield kit	1	1	1	1	1	1	1	1	1	1	1	1	1	1	1	1
1	803145	Glass plate, front	1	1	1	1	1	1	1	1	1	1	1	1	1	1	1	1
2	803143	Glass plate, rear	1	1	1	1	1	1	1	1	1	1	1	1	1	1	1	1
3	803141	Glass plate, top	1	1	1	1	1	1	1	1	1	1	1	1	1	1	1	1
4	Z4056	Gasket, front, 140 in.	1	1	1	1	1	1	1	1	1	1	1	1	1	1	1	1
5	Z4056	Gasket, rear, 117 in.	1	1	1	1	1	1	1	1	1	1	1	1	1	1	1	1
6	Z4053	Trim-Lock, 122 in.	1	1	1	1	1	1	1	1	1	1	1	1	1	1	1	1

8 AA 124

WINDSHIELD KIT, 77 AND 81 IN. OPEN CAB (HYDROSTATIC OR 4-SPEED)

M30-2	M30-4	M30-2 H	M30-4 H
M40-2	M40-4	M40-2 H	M40-4 H
M50-2	M50-4	M50-2 H	M50-4 H
M60-2	M60-4	M60-2 H	M60-4 H
M30-2 L	M30-4 L	M30-2 H L	M30-4 H L
M40-2 L	M40-4 L	M40-2 H L	M40-4 H L
M50-2 L	M50-4 L	M50-2 H L	M50-4 H L
M60-2 L	M60-4 L	M60-2 H L	M60-4 H L

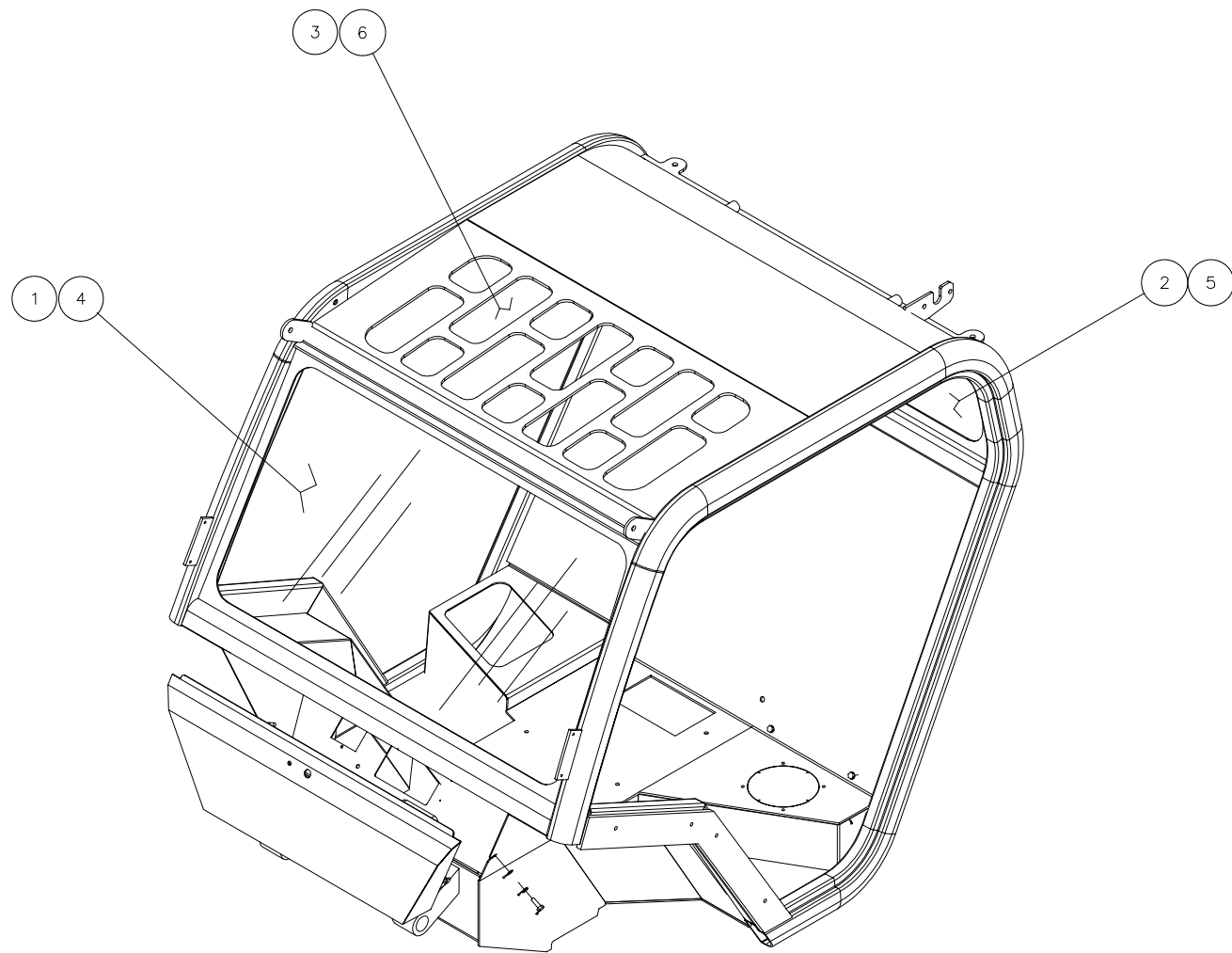

INSTALL TRIM-LOCK (ITEM 6) WITH BLACK URETHANE WINDSHIELD ADHESIVE.

ITEM	PART NO.	DESCRIPTION	QUANTITY / MODEL												8 AA 124			
			M30-2	M40-2	M50-2	M60-2	M30-2 H	M40-2 H	M50-2 H	M60-2 H	M30-2 L	M40-2 L	M50-2 L	M60-2 L	M30-4 H L	M40-4 H L	M50-4 H L	M60-4 H L
1	803138	Windshield kit	1	1	1	1	1	1	1	1	1	1	1	1	1	1	1	1
1	803144	Glass plate, front	1	1	1	1	1	1	1	1	1	1	1	1	1	1	1	1
2	803142	Glass plate, rear	1	1	1	1	1	1	1	1	1	1	1	1	1	1	1	1
3	803140	Glass plate, top	1	1	1	1	1	1	1	1	1	1	1	1	1	1	1	1
4	Z4056	Gasket, front, 117 in.	1	1	1	1	1	1	1	1	1	1	1	1	1	1	1	1
5	Z4056	Gasket, rear, 89 in.	1	1	1	1	1	1	1	1	1	1	1	1	1	1	1	1
6	Z4053	Trim-Lock, 115 in.	1	1	1	1	1	1	1	1	1	1	1	1	1	1	1	1

9 AA 10

SIDE PANELS, REAR FENDERS, AND HOOD LIFT CYLINDER

M30-2	M30-4	M30-2 H	M30-4 H
M40-2	M40-4	M40-2 H	M40-4 H
M50-2	M50-4	M50-2 H	M50-4 H
M60-2	M60-4	M60-2 H	M60-4 H
M30-2 L	M30-4 L	M30-2 H L	M30-4 H L
M40-2 L	M40-4 L	M40-2 H L	M40-4 H L
M50-2 L	M50-4 L	M50-2 H L	M50-4 H L
M60-2 L	M60-4 L	M60-2 H L	M60-4 H L

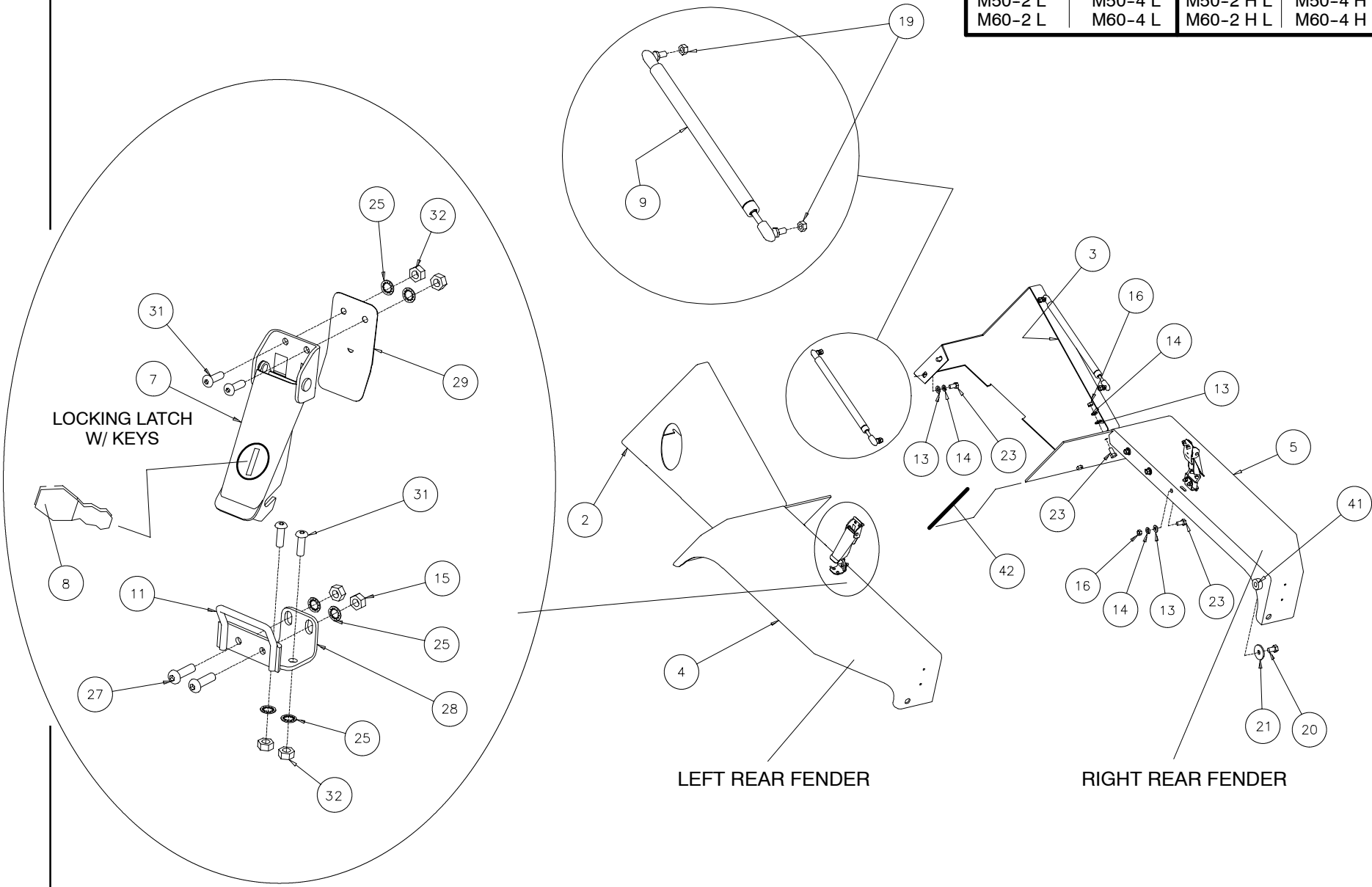

1	SIDE PANELS, REAR FENDERS, AND HOOD LIFT CYLINDER												9 AA 10						
	ITEM	PART NO.	DESCRIPTION	M30-2	M40-2	M50-2	M60-2	M30-2 H	M40-2 H	M50-2 H	M60-2 H	M30-2 L	M40-2 L	M50-2 L	M60-2 L	M30-2 H L	M40-2 H L	M50-2 H L	M60-2 H L
2A	802239	Panel, LH cover - 1st mounting (use w/ 802925 Filler, tall - see 4AC10)	1	1	1	1	1	1	1	1	1	1	1	1	1	1	1	1	1
2B	803451	Panel, LH cover - 2nd mounting (use w/ 803453 Filler, short - see 4AC10)	1	1	1	1	1	1	1	1	1	1	1	1	1	1	1	1	1
3	802242	Panel, RH cover	1	1	1	1	1	1	1	1	1	1	1	1	1	1	1	1	1
4A	802615	Fender, LH rear (all except M30 trucks, S/N: 750480 & above)	1	1	1	1	1	1	1	1	1	1	1	1	1	1	1	1	1
4B	804326	Fender, LH rear (M30 trucks only, S/N: 750480 & above)	1				1				1				1				
5A	802616	Fender, RH rear (all except M30 trucks, S/N: 750480 & above)	1	1	1	1	1	1	1	1	1	1	1	1	1	1	1	1	1
5B	804327	Fender, RH rear (M30 trucks only, S/N: 750480 & above)	1				1				1				1				
7	223902	Latch, locking, w/ keys	2	2	2	2	2	2	2	2	2	2	2	2	2	2	2	2	2
8	581732	Key, hood latch	1	1	1	1	1	1	1	1	1	1	1	1	1	1	1	1	1
9	209115	Air spring	2	2	2	2	2	2	2	2	2	2	2	2	2	2	2	2	2
11	223904	Hook, latch	2	2	2	2	2	2	2	2	2	2	2	2	2	2	2	2	2
13	29437	Washer, flat	6	6	6	6	6	6	6	6	6	6	6	6	6	6	6	6	6
14	42232	Washer, lock	6	6	6	6	6	6	6	6	6	6	6	6	6	6	6	6	6
15	25714	Nut	12	12	12	12	12	12	12	12	12	12	12	12	12	12	12	12	12
16	56354	Nut	4	4	4	4	4	4	4	4	4	4	4	4	4	4	4	4	4
19	3212	Nut	2	2	2	2	2	2	2	2	2	2	2	2	2	2	2	2	2
20	63546	Bolt	2	2	2	2	2	2	2	2	2	2	2	2	2	2	2	2	2
21	44026	Washer, special	2	2	2	2	2	2	2	2	2	2	2	2	2	2	2	2	2
23	5804	Bolt	6	6	6	6	6	6	6	6	6	6	6	6	6	6	6	6	6
25	174132	Washer, lock	12	12	12	12	12	12	12	12	12	12	12	12	12	12	12	12	12
27	205275	Screw	4	4	4	4	4	4	4	4	4	4	4	4	4	4	4	4	4
28	802874	Bracket, hood latch	2	2	2	2	2	2	2	2	2	2	2	2	2	2	2	2	2
29	223903	Spring	2	2	2	2	2	2	2	2	2	2	2	2	2	2	2	2	2
31	184036	Screw	8	8	8	8	8	8	8	8	8	8	8	8	8	8	8	8	8
32	54232	Nut	4	4	4	4	4	4	4	4	4	4	4	4	4	4	4	4	4
41	803079	Washer, special	2	2	2	2	2	2	2	2	2	2	2	2	2	2	2	2	2
42	Z4053-10	Trim lock, 10 in.	2	2	2	2	2	2	2	2	2	2	2	2	2	2	2	2	2

9 AA 11

ENGINE COVER AND COUNTERWEIGHT COVER

M30-2	M30-4	M30-2 H	M30-4 H
M40-2	M40-4	M40-2 H	M40-4 H
M50-2	M50-4	M50-2 H	M50-4 H
M60-2	M60-4	M60-2 H	M60-4 H
M30-2 L	M30-4 L	M30-2 H L	M30-4 H L
M40-2 L	M40-4 L	M40-2 H L	M40-4 H L
M50-2 L	M50-4 L	M50-2 H L	M50-4 H L
M60-2 L	M60-4 L	M60-2 H L	M60-4 H L

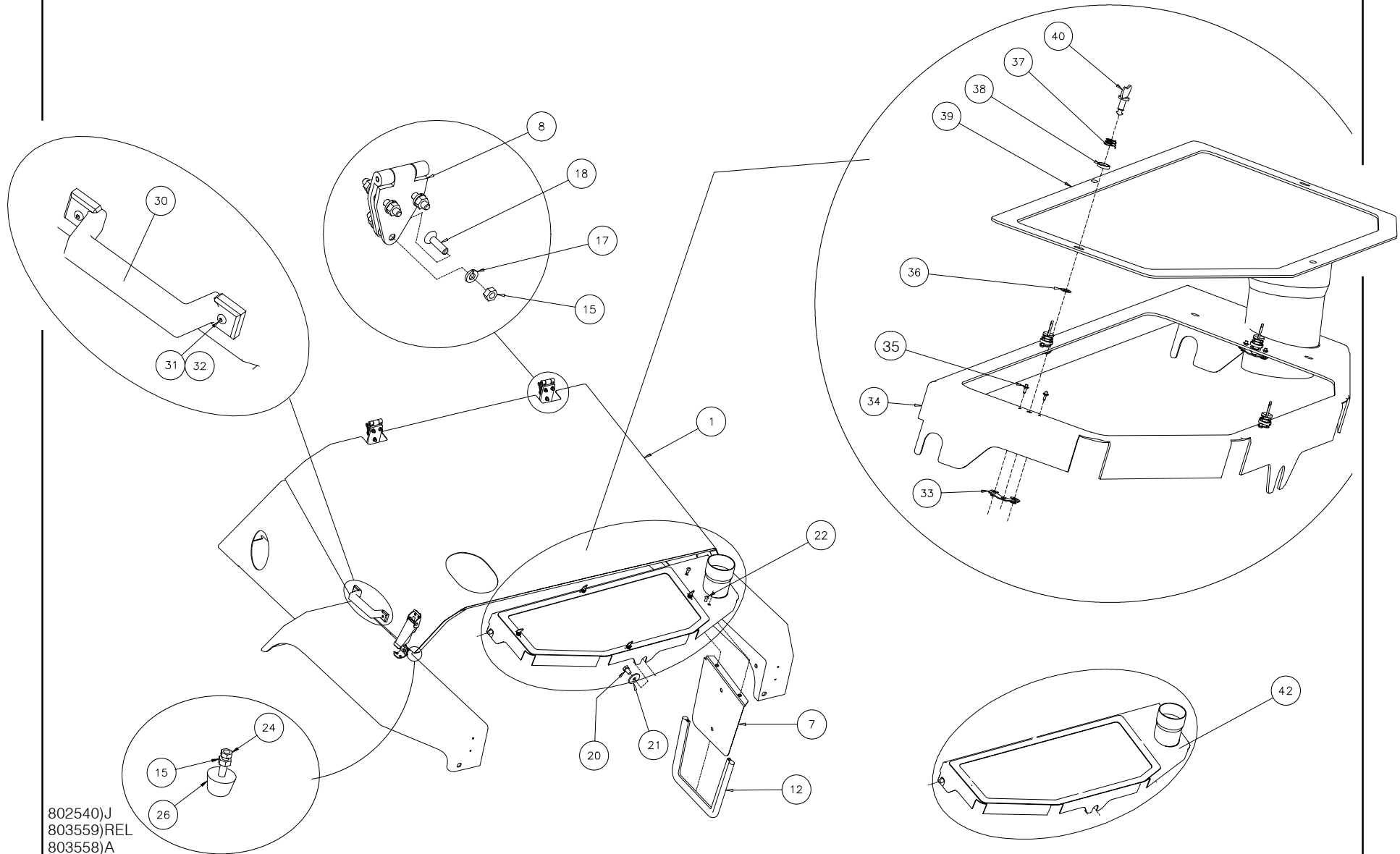

802540)J
 803559)REL
 803558)A
 804328)REL

1	ENGINE COVER AND COUNTERWEIGHT COVER												9 AA 11						
	ITEM	PART NO.	DESCRIPTION	M30-2	M40-2	M50-2	M60-2	M30-2 H	M40-2 H	M50-2 H	M60-2 H	M30-2 L	M40-2 L	M50-2 L	M60-2 L	M30-2 H L	M40-2 H L	M50-2 H L	M60-2 H L
1A	802538	Hood - 1st mounting, w/ exhaust pipe opening (S/N: 750173, 750171 & below)	1	1	1	1	1	1	1	1	1	1	1	1	1	1	1	1	1
1B	803677	Hood - 2nd mounting, less exhaust pipe opening (S/N: 750172 & above, except 750173)	1	1	1	1	1	1	1	1	1	1	1	1	1	1	1	1	1
7	224345	Air baffle	1	1	1	1	1	1	1	1	1	1	1	1	1	1	1	1	1
8	79570	Hinge	2	2	2	2	2	2	2	2	2	2	2	2	2	2	2	2	2
12	Z4054-27	Seal, strip, 27 in.	1	1	1	1	1	1	1	1	1	1	1	1	1	1	1	1	1
15	25714	Nut	8	8	8	8	8	8	8	8	8	8	8	8	8	8	8	8	8
17	42316	Washer, lock	6	6	6	6	6	6	6	6	6	6	6	6	6	6	6	6	6
18	29441	Screw	6	6	6	6	6	6	6	6	6	6	6	6	6	6	6	6	6
20	63546	Bolt	1	1	1	1	1	1	1	1	1	1	1	1	1	1	1	1	1
21	44026	Washer, special	1	1	1	1	1	1	1	1	1	1	1	1	1	1	1	1	1
22	202731	Screw	2	2	2	2	2	2	2	2	2	2	2	2	2	2	2	2	2
24	162229	Nut, lock	2	2	2	2	2	2	2	2	2	2	2	2	2	2	2	2	2
26	53501	Block, silent	2	2	2	2	2	2	2	2	2	2	2	2	2	2	2	2	2
30	424186	Handle	2	2	2	2	2	2	2	2	2	2	2	2	2	2	2	2	2
31	184036	Screw	4	4	4	4	4	4	4	4	4	4	4	4	4	4	4	4	4
32	54232	Nut	4	4	4	4	4	4	4	4	4	4	4	4	4	4	4	4	4
33	802944	Receptacle, large	4	4	4	4	4	4	4	4	4	4	4	4	4	4	4	4	4
34	802769	Cover, counterweight	1	1	1	1	1	1	1	1	1	1	1	1	1	1	1	1	1
35	B254-3	Rivet	8	8	8	8	8	8	8	8	8	8	8	8	8	8	8	8	8
36	802943	Retainer, push-on	4	4	4	4	4	4	4	4	4	4	4	4	4	4	4	4	4
37	802946	Spring, stud ejector	4	4	4	4	4	4	4	4	4	4	4	4	4	4	4	4	4
38	802945	Washer, cupped nylon	4	4	4	4	4	4	4	4	4	4	4	4	4	4	4	4	4
39	802884	Screen	1	1	1	1	1	1	1	1	1	1	1	1	1	1	1	1	1
40	802942	Stud, wing head recess	4	4	4	4	4	4	4	4	4	4	4	4	4	4	4	4	4
42	241607	Cover, counterweight, w/ permanent screen	1	1	1	1	1	1	1	1	1	1	1	1	1	1	1	1	1

10 AA 10

HYDRAULIC TANK ASSEMBLY, 4-SPEED TRANSMISSION

M30-2	M30-4		
M40-2	M40-4		
M50-2	M50-4		
M60-2	M60-4		
M30-2 L	M30-4 L		
M40-2 L	M40-4 L		
M50-2 L	M50-4 L		
M60-2 L	M60-4 L		

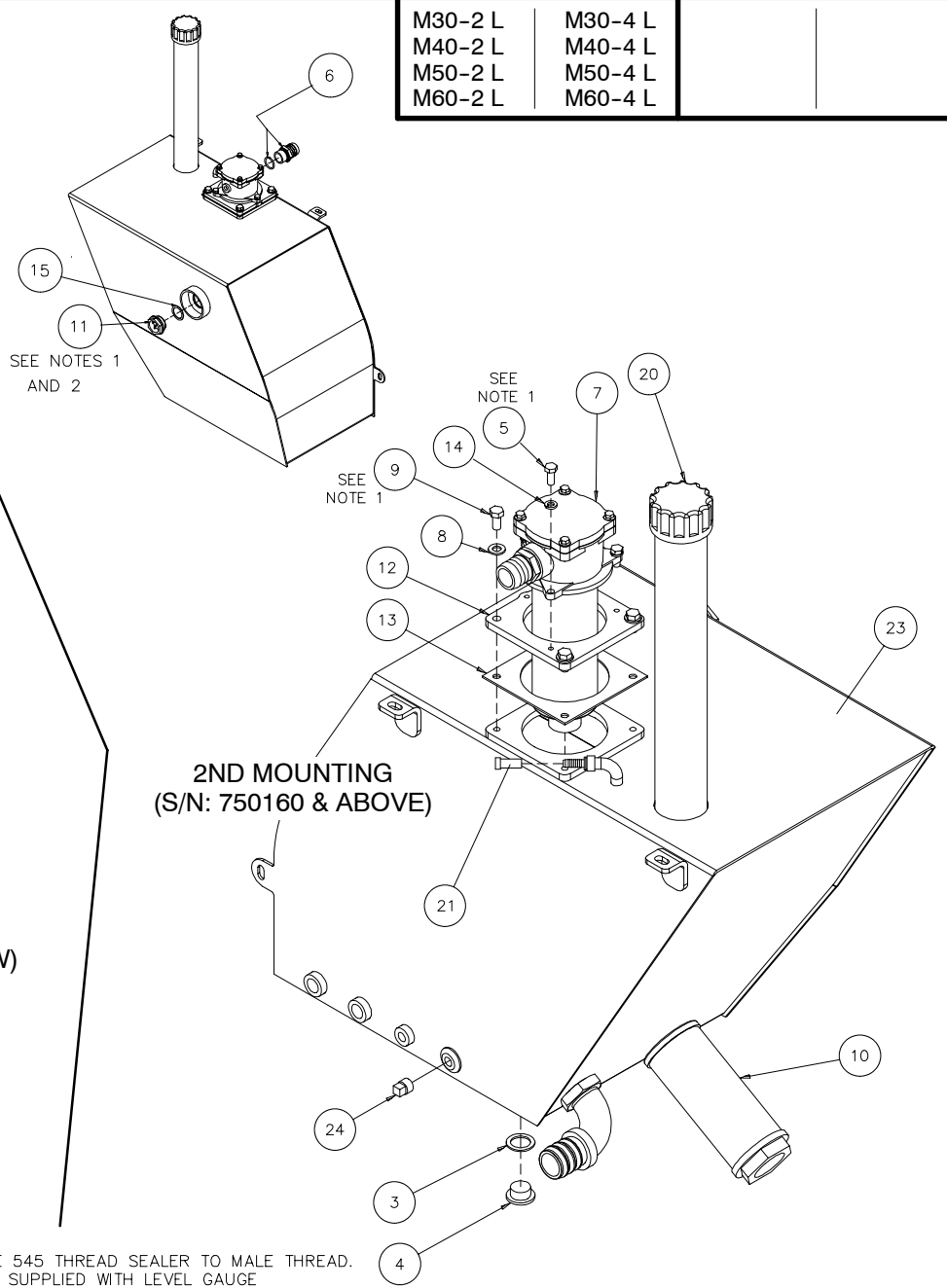
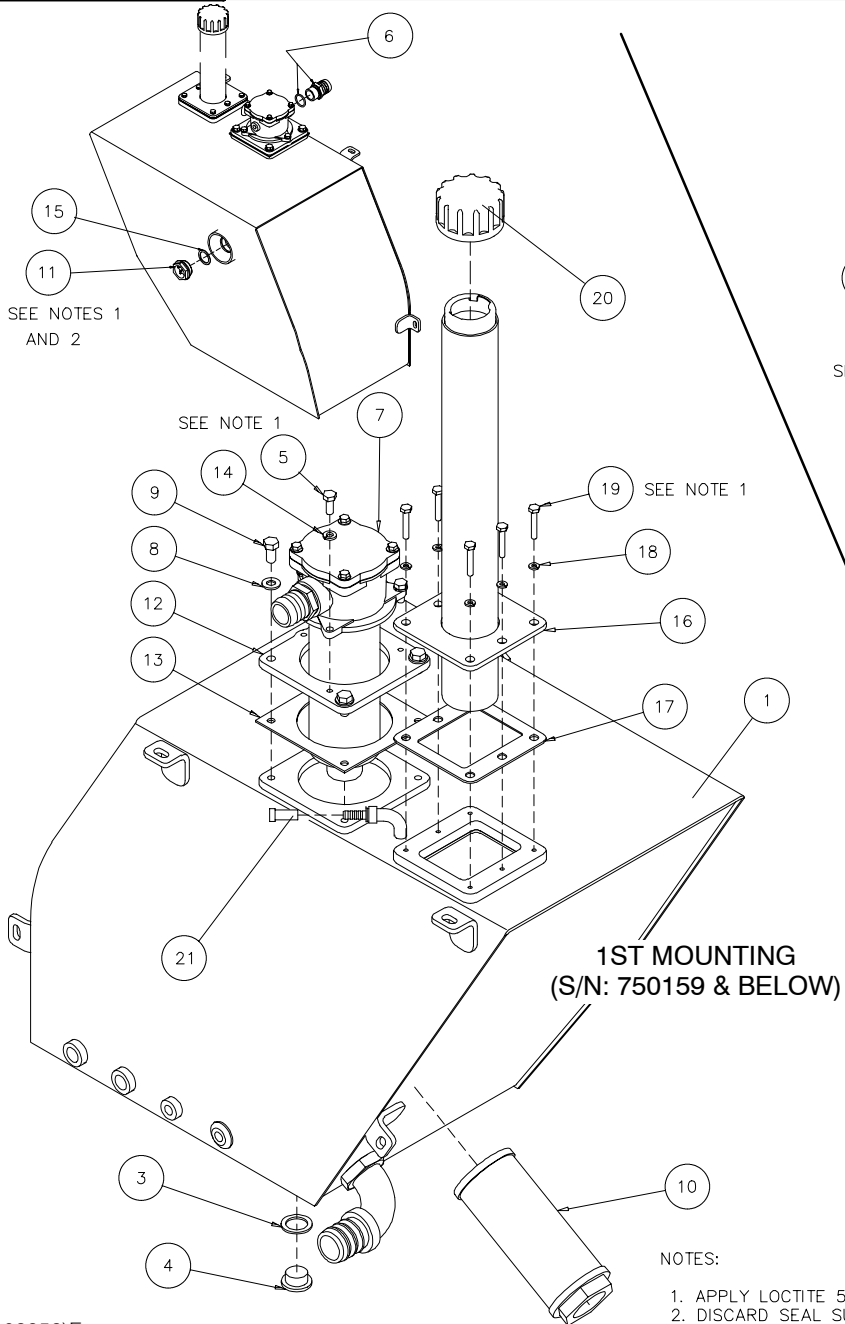

			QUANTITY / MODEL								10 AA 10							
1 HYDRAULIC TANK ASSEMBLY, 4-SPEED TRANSMISSION			M30-4	M40-4	M50-4	M60-4					M30-4 L	M40-4 L	M50-4 L	M60-4 L				
ITEM	PART NO.	DESCRIPTION	M30-2	M40-2	M50-2	M60-2					M30-2 L	M40-2 L	M50-2 L	M60-2 L				
1	802162	Tank, hydraulic - S/N: 750159 & below	1	1	1	1					1	1	1	1				
3	189536	Seal, drain plug	1	1	1	1					1	1	1	1				
4	189535	Drain plug	1	1	1	1					1	1	1	1				
5	42347	Bolt	3	3	3	3					3	3	3	3				
6	176864	Adapter, hose	1	1	1	1					1	1	1	1				
7	221172	Filter assembly, complete - see 10AA40	1	1	1	1					1	1	1	1				
8	29437	Washer, flat	4	4	4	4					4	4	4	4				
9	63727	Bolt	4	4	4	4					4	4	4	4				
10	424764	Stainer, hydraulic suction	1	1	1	1					1	1	1	1				
11	488236	Level gauge	1	1	1	1					1	1	1	1				
12	802263	Filter mounting plate	1	1	1	1					1	1	1	1				
13	802354	Gasket, filter adapter	1	1	1	1					1	1	1	1				
14	42325	Washer, lock	3	3	3	3					3	3	3	3				
15	K8-326	Seal	1	1	1	1					1	1	1	1				
16	802907	Filler, weld assembly	1	1	1	1					1	1	1	1				
17	802909	Gasket, hydraulic tank	1	1	1	1					1	1	1	1				
18	K34791	Washer, lock	6	6	6	6					6	6	6	6				
19	K20344	Bolt	6	6	6	6					6	6	6	6				
20	425501	Filler cap, vented	1	1	1	1					1	1	1	1				
21	803039	Cap	1	1	1	1					1	1	1	1				
23	803532	Tank, hydraulic - S/N: 750160 & above	1	1	1	1					1	1	1	1				
24	B114A3	Plug	1	1	1	1					1	1	1	1				

10 AA 20

HYDRAULIC TANK ASSEMBLY, HYDROSTATIC TRANSMISSION

M30-2 H	M30-4 H
M40-2 H	M40-4 H
M50-2 H	M50-4 H
M60-2 H	M60-4 H
M30-2 H L	M30-4 H L
M40-2 H L	M40-4 H L
M50-2 H L	M50-4 H L
M60-2 H L	M60-4 H L

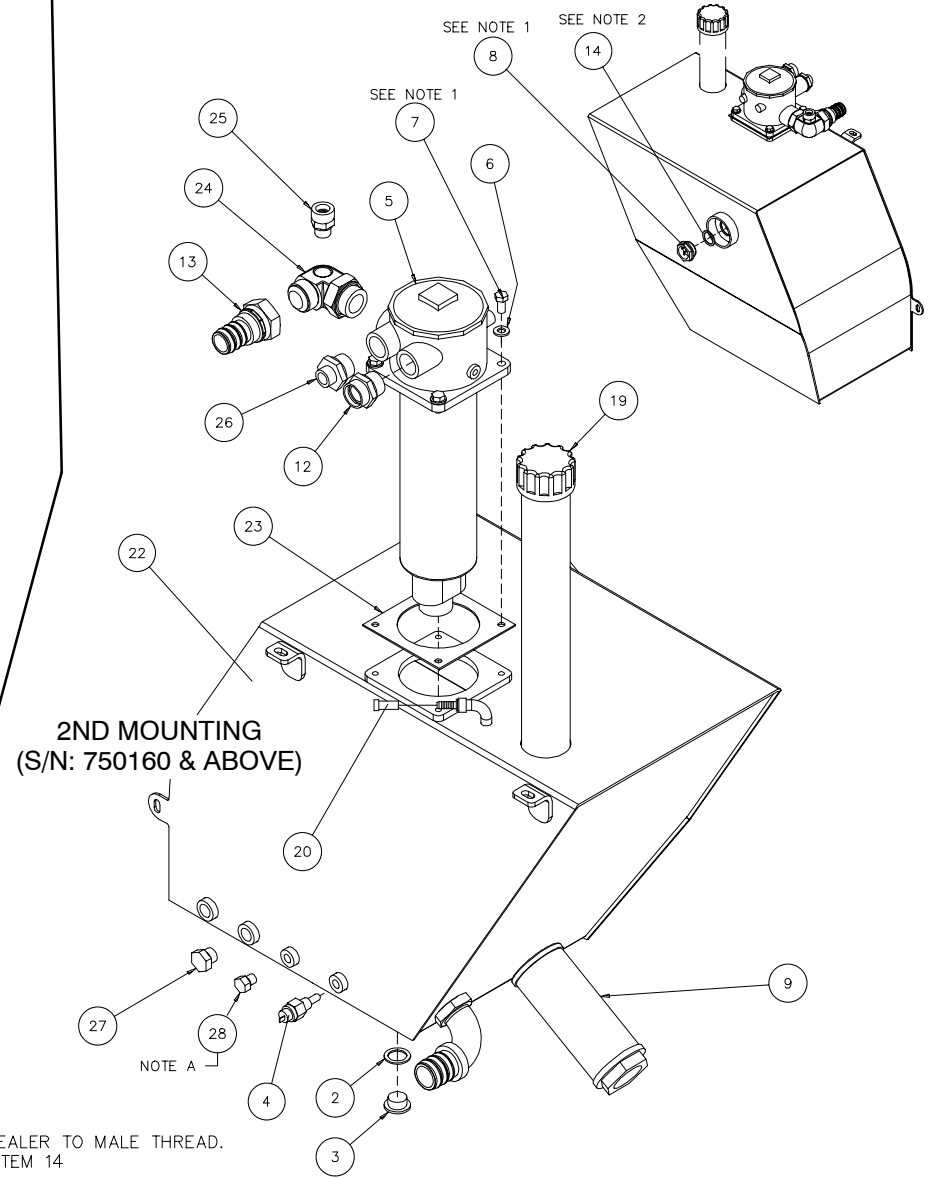
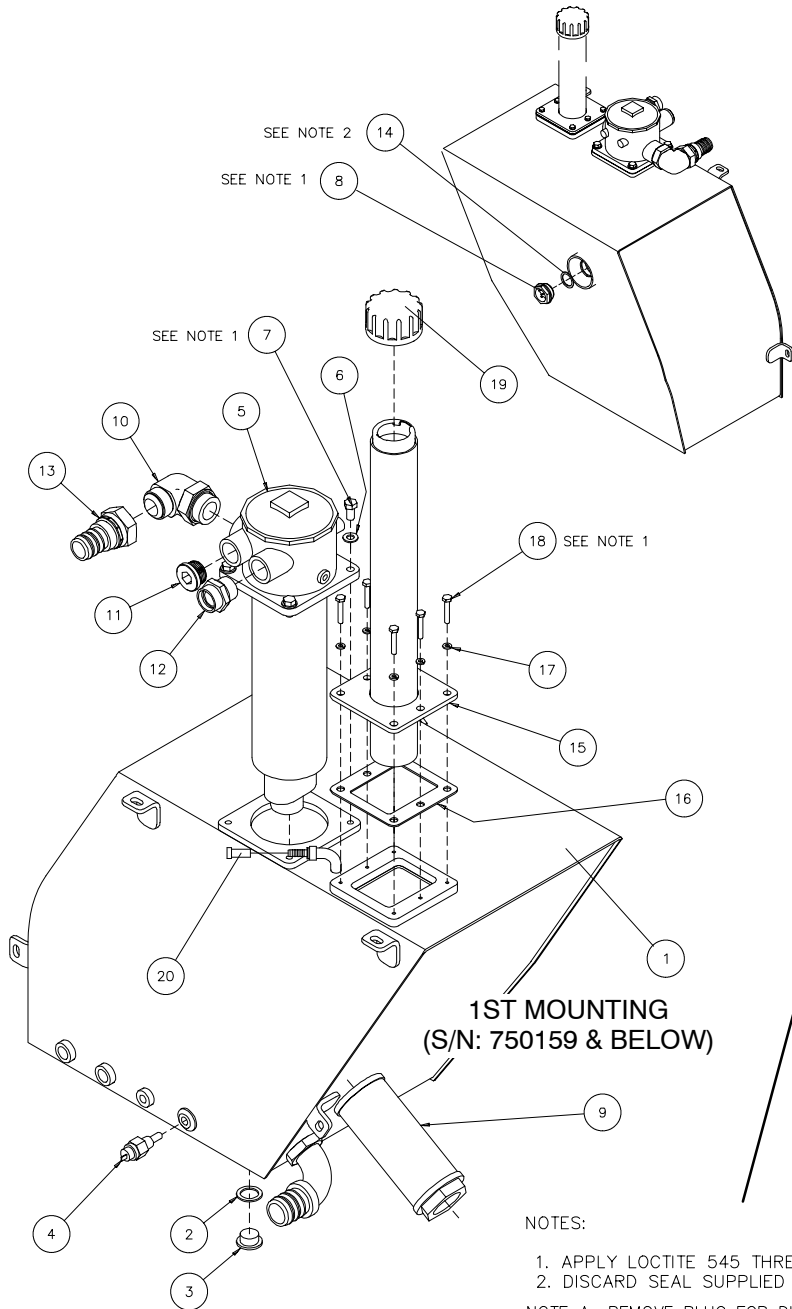

NOTES:

1. APPLY LOCTITE 545 THREAD SEALER TO MALE THREAD.
 2. DISCARD SEAL SUPPLIED USE ITEM 14
- NOTE A: REMOVE PLUG FOR DIFF LOCK OPTION.

1	HYDRAULIC TANK ASSEMBLY, HYDROSTATIC TRANSMISSION		QUANTITY / MODEL								10 AA 20							
							M30-4 H	M40-4 H	M50-4 H	M60-4 H					M30-4 H L	M40-4 H L	M50-4 H L	M60-4 H L
ITEM	PART NO.	DESCRIPTION					M30-2 H	M40-2 H	M50-2 H	M60-2 H					M30-2 H L	M40-2 H L	M50-2 H L	M60-2 H L
1	802162	Tank, hydraulic - S/N: 750159 & below					1	1	1	1					1	1	1	1
2	189536	Seal, drain plug					1	1	1	1					1	1	1	1
3	189535	Drain plug					1	1	1	1					1	1	1	1
4	425497	Temp switch					1	1	1	1					1	1	1	1
5	234292	Filter assembly, complete - see 10AA40					1	1	1	1					1	1	1	1
6	29437	Washer, flat					4	4	4	4					4	4	4	4
7	63727	Bolt					4	4	4	4					4	4	4	4
8	488236	Level gauge					1	1	1	1					1	1	1	1
9	424764	Stainer, hydraulic suction					1	1	1	1					1	1	1	1
10	802274	Adapter					1	1	1	1					1	1	1	1
11	802276	Plug					1	1	1	1					1	1	1	1
12	803269	Connector					1	1	1	1					1	1	1	1
13	802451	Fitting					1	1	1	1					1	1	1	1
14	K8-326	Ring, back-up					1	1	1	1					1	1	1	1
15	802907	Filler, weld assembly					1	1	1	1					1	1	1	1
16	802909	Gasket, hydraulic tank					1	1	1	1					1	1	1	1
17	K34791	Washer, lock					6	6	6	6					6	6	6	6
18	K20344	Bolt					6	6	6	6					6	6	6	6
19	425501	Filler cap, vented					1	1	1	1					1	1	1	1
20	803039	Cap					1	1	1	1					1	1	1	1
22	803532	Tank, hydraulic - S/N: 750160 & above					1	1	1	1					1	1	1	1
23	802354	Gasket					1	1	1	1					1	1	1	1
24	803733	Elbow, tapped					1	1	1	1					1	1	1	1
25	213400	Adapter					1	1	1	1					1	1	1	1
26	803735	Connector					1	1	1	1					1	1	1	1
27	175743	Plug					1	1	1	1					1	1	1	1
28	803966	Plug					1	1	1	1					1	1	1	1

10 AA 30

OIL COOLER, HYDRASTATIC, POULTRY, OPTIONAL KIT

M30-2	M30-4	M30-2 H	M30-4 H
M40-2	M40-4	M40-2 H	M40-4 H
M50-2	M50-4	M50-2 H	M50-4 H
M60-2	M60-4	M60-2 H	M60-4 H
M30-2 L	M30-4 L	M30-2 H L	M30-4 H L
M40-2 L	M40-4 L	M40-2 H L	M40-4 H L
M50-2 L	M50-4 L	M50-2 H L	M50-4 H L
M60-2 L	M60-4 L	M60-2 H L	M60-4 H L

1ST MOUNTING, UPDATED S/N: 750457 & BELOW

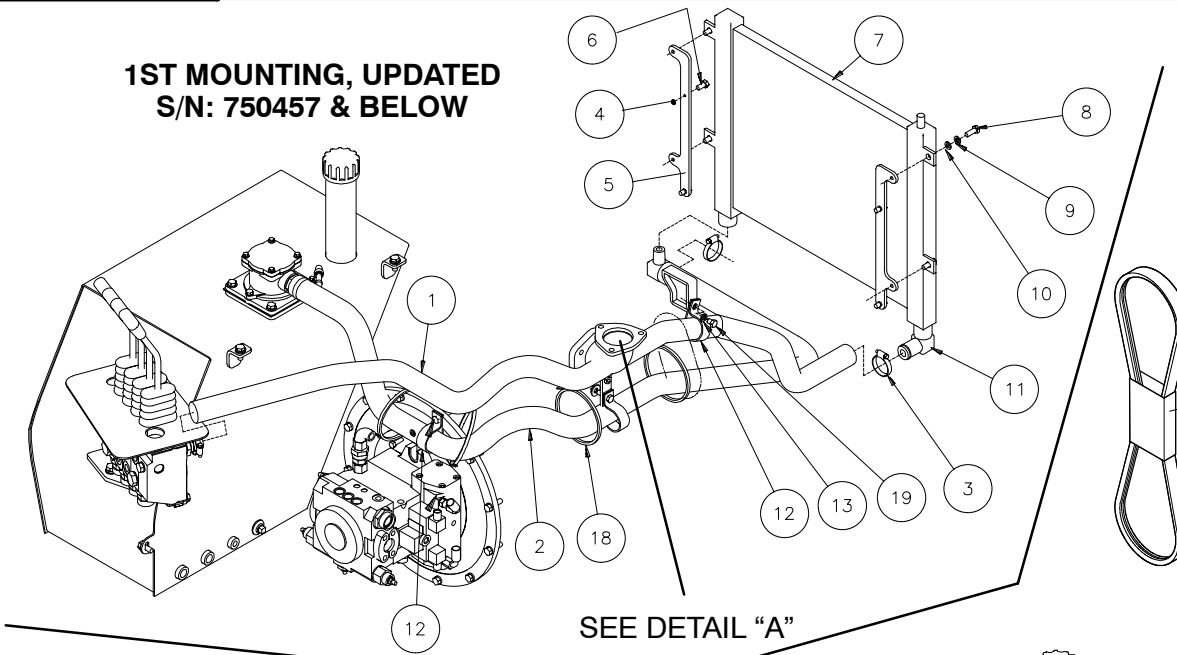

SEE DETAIL "A"

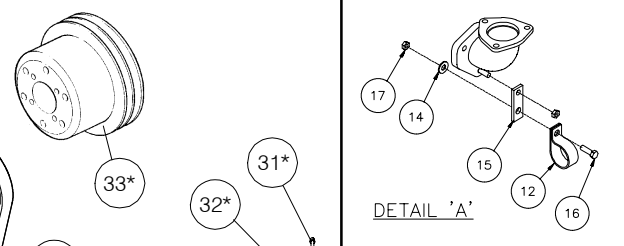

DETAIL "A"

2ND MOUNTING S/N: 750458 & ABOVE

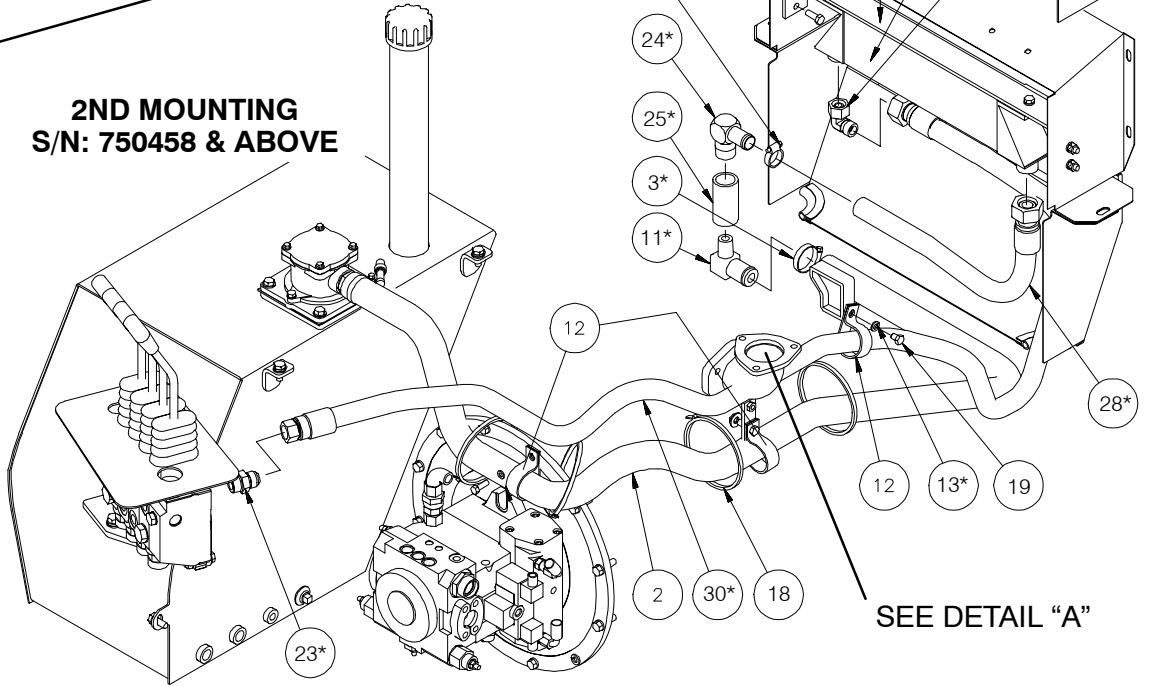

SEE DETAIL "A"

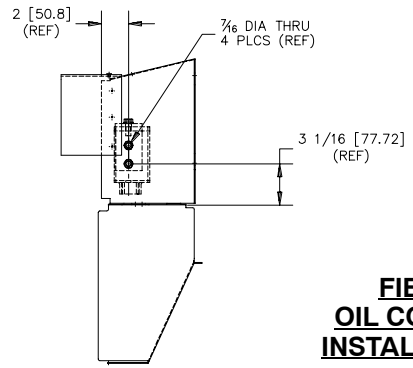

FIELD OIL COOLER INSTALLATION

1. UNBOLT & REMOVE OLD OIL COOLER (IF INSTALLED).
2. ALIGN OIL COOLER & BRACKET PER THE DIMENSIONS AT LEFT.
3. MATCH DRILL $\frac{7}{16}$ DIA. HOLES AND BOLT IN NEW OIL COOLER.
4. INSTALL HOSES AND FITTINGS AS SHOWN.
5. TRIM, DRILL, AND ATTACH RUBBER SEAL AS NEEDED TO INSURE RADIATOR AIR FLOW IS ISOLATED FROM ENGINE HEAT.

803410)B
804020)B
804594)B
804009)B

1	OIL COOLER, HYDRASTATIC, POULTRY, OPTIONAL KIT											QUANTITY / MODEL											
												10 AA 30											
												M30-4	M40-4	M50-4	M60-4	M30-4 H	M40-4 H	M50-4 H	M60-4 H	M30-4 L	M40-4 L	M50-4 L	M60-4 L
ITEM	PART NO.	DESCRIPTION	M30-2	M40-2	M50-2	M60-2	M30-2 H	M40-2 H	M50-2 H	M60-2 H	M30-2 L	M40-2 L	M50-2 L	M60-2 L	M30-2 H L	M40-2 H L	M50-2 H L	M60-2 H L					
1	803730	Hose	1	1	1	1	1	1	1	1	1	1	1	1	1	1	1	1					
2	803729	Hose	1	1	1	1	1	1	1	1	1	1	1	1	1	1	1	1					
3A	804776	Hose clamp	2	2	2	2	2	2	2	2	2	2	2	2	2	2	2	2					
3B*	31089	Hose clamp	1	1	1	1	1	1	1	1	1	1	1	1	1	1	1	1					
4	K34053	Nut	2	2	2	2	2	2	2	2	2	2	2	2	2	2	2	2					
5	496702	Bracket, cooler mount	2	2	2	2	2	2	2	2	2	2	2	2	2	2	2	2					
6	K54089SS	Screw	4	4	4	4	4	4	4	4	4	4	4	4	4	4	4	4					
7	494496	Oil cooler	1	1	1	1	1	1	1	1	1	1	1	1	1	1	1	1					
8	K20388SS	Bolt	4	4	4	4	4	4	4	4	4	4	4	4	4	4	4	4					
9	K34807SS	Washer, lock	4	4	4	4	4	4	4	4	4	4	4	4	4	4	4	4					
10	K44728SS	Washer, flat	4	4	4	4	4	4	4	4	4	4	4	4	4	4	4	4					
11*	803409	Hose insert, beaded	2	2	2	2	2	2	2	2	2	2	2	2	2	2	2	2					
12	B3698-25	Clamp	3	3	3	3	3	3	3	3	3	3	3	3	3	3	3	3					
13*	K34807	Washer, lock	1	1	1	1	1	1	1	1	1	1	1	1	1	1	1	1					
14	K44728	Washer, flat	1	1	1	1	1	1	1	1	1	1	1	1	1	1	1	1					
15	803726	Mounting tab	1	1	1	1	1	1	1	1	1	1	1	1	1	1	1	1					
16	K20428	Bolt	1	1	1	1	1	1	1	1	1	1	1	1	1	1	1	1					
17	K55748	Nut	2	2	2	2	2	2	2	2	2	2	2	2	2	2	2	2					
18	496810	Tie wrap	4	4	4	4	4	4	4	4	4	4	4	4	4	4	4	4					
19	K20312	Bolt	1	1	1	1	1	1	1	1	1	1	1	1	1	1	1	1					
20*	802652	Oil cooler	1	1	1	1	1	1	1	1	1	1	1	1	1	1	1	1					
21*	803828	Bracket, cooler mount	1	1	1	1	1	1	1	1	1	1	1	1	1	1	1	1					
22*	218258	Fitting	1	1	1	1	1	1	1	1	1	1	1	1	1	1	1	1					
23*	804010	Fitting	1	1	1	1	1	1	1	1	1	1	1	1	1	1	1	1					
24*	800973	Fitting	1	1	1	1	1	1	1	1	1	1	1	1	1	1	1	1					
25*	B110A8	Coupling	1	1	1	1	1	1	1	1	1	1	1	1	1	1	1	1					
26*	K33799	Nut	4	4	4	4	4	4	4	4	4	4	4	4	4	4	4	4					
27*	K20388	Bolt	6	6	6	6	6	6	6	6	6	6	6	6	6	6	6	6					

2	OIL COOLER, HYDRASTATIC, POULTRY, OPTIONAL KIT		QUANTITY / MODEL												10 AA 30			
			M30-4	M40-4	M50-4	M60-4	M30-4 H	M40-4 H	M50-4 H	M60-4 H	M30-4 L	M40-4 L	M50-4 L	M60-4 L	M30-4 H L	M40-4 H L	M50-4 H L	M60-4 H L
ITEM	PART NO.	DESCRIPTION	M30-2	M40-2	M50-2	M60-2	M30-2 H	M40-2 H	M50-2 H	M60-2 H	M30-2 L	M40-2 L	M50-2 L	M60-2 L	M30-2 H L	M40-2 H L	M50-2 H L	M60-2 H L
28*	804018	Hose assembly	1	1	1	1	1	1	1	1	1	1	1	1	1	1	1	1
29*	425394	Hose clamp	1	1	1	1	1	1	1	1	1	1	1	1	1	1	1	1
30*	804017	Hose assembly	1	1	1	1	1	1	1	1	1	1	1	1	1	1	1	1
31*	77808	Pop rivet	16	16	16	16	16	16	16	16	16	16	16	16	16	16	16	16
32*	525829	Rubber seal strip	2	2	2	2	2	2	2	2	2	2	2	2	2	2	2	2
33*	552639	Fan pulley	1	1	1	1	1	1	1	1	1	1	1	1	1	1	1	1
34*	496816	Fan belt	1	1	1	1	1	1	1	1	1	1	1	1	1	1	1	1
		* Items required for Field Oil Cooler Installation.																

10 AA 40

FILTER ASSEMBLIES, HYDRAULIC TANK

M30-2	M30-4	M30-2 H	M30-4 H
M40-2	M40-4	M40-2 H	M40-4 H
M50-2	M50-4	M50-2 H	M50-4 H
M60-2	M60-4	M60-2 H	M60-4 H
M30-2 L	M30-4 L	M30-2 H L	M30-4 H L
M40-2 L	M40-4 L	M40-2 H L	M40-4 H L
M50-2 L	M50-4 L	M50-2 H L	M50-4 H L
M60-2 L	M60-4 L	M60-2 H L	M60-4 H L

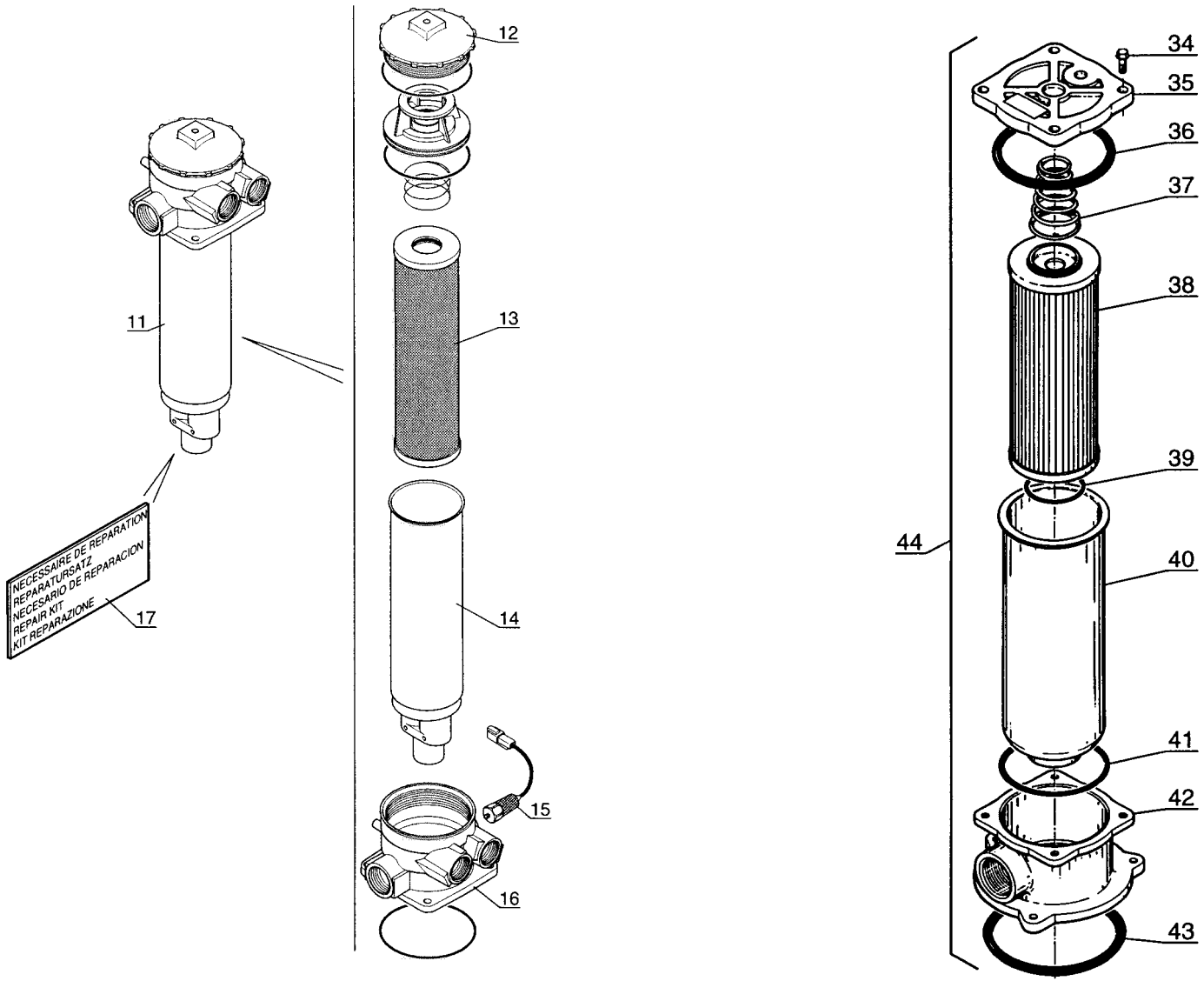

NECESSAIRE DE REPARATION
 REPARATURSATZ
 NECESARIO DE REPARACION
 REPAIR KIT
 KIT REPARAZIONE

1	FILTER ASSEMBLIES, HYDRAULIC TANK		QUANTITY / MODEL												10 AA 40			
			M30-4	M40-4	M50-4	M60-4	M30-4 H	M40-4 H	M50-4 H	M60-4 H	M30-4 L	M40-4 L	M50-4 L	M60-4 L	M30-4 H L	M40-4 H L	M50-4 H L	M60-4 H L
ITEM	PART NO.	DESCRIPTION	M30-2	M40-2	M50-2	M60-2	M30-2 H	M40-2 H	M50-2 H	M60-2 H	M30-2 L	M40-2 L	M50-2 L	M60-2 L	M30-2 H L	M40-2 H L	M50-2 H L	M60-2 H L
11	234292	Hydraulic return oil filter, complete, hydrostatic					1	1	1	1					1	1	1	1
12	602094	Cover					1	1	1	1					1	1	1	1
13	602096	Filter cartridge					1	1	1	1					1	1	1	1
14	602097	Tube					1	1	1	1					1	1	1	1
15	602099	Switch, filter clogging					1	1	1	1					1	1	1	1
16	602095	Body, filter return					1	1	1	1					1	1	1	1
17	602098	Filter kit					1	1	1	1					1	1	1	1
34	562461	Screw	4	4	4	4					4	4	4	4				
35	562086	Cover	1	1	1	1					1	1	1	1				
36	48384	O-ring	1	1	1	1					1	1	1	1				
37	562088	Spring	1	1	1	1					1	1	1	1				
38	221174	Filter cartridge	1	1	1	1					1	1	1	1				
39	562092	O-ring	1	1	1	1					1	1	1	1				
40	562095	Tube	1	1	1	1					1	1	1	1				
41	562090	Seal	1	1	1	1					1	1	1	1				
42	562089	Body, filter return	1	1	1	1					1	1	1	1				
43	562093	Seal	1	1	1	1					1	1	1	1				
44	221172	Hydraulic return oil filter, complete, 4-speed	1	1	1	1					1	1	1	1				

10 AE 10

HYDRAULIC SYSTEM, PUMP AND CONTROLS

M30-2	M30-4	M30-2 H	M30-4 H
M40-2	M40-4	M40-2 H	M40-4 H
M50-2	M50-4	M50-2 H	M50-4 H
M60-2	M60-4	M60-2 H	M60-4 H
M30-2 L	M30-4 L	M30-2 H L	M30-4 H L
M40-2 L	M40-4 L	M40-2 H L	M40-4 H L
M50-2 L	M50-4 L	M50-2 H L	M50-4 H L
M60-2 L	M60-4 L	M60-2 H L	M60-4 H L

NOTE:
 DELETE ITEM 55 W/COOLER OPTION
 DELETE ITEM 55 W/ POULTRY OPTION

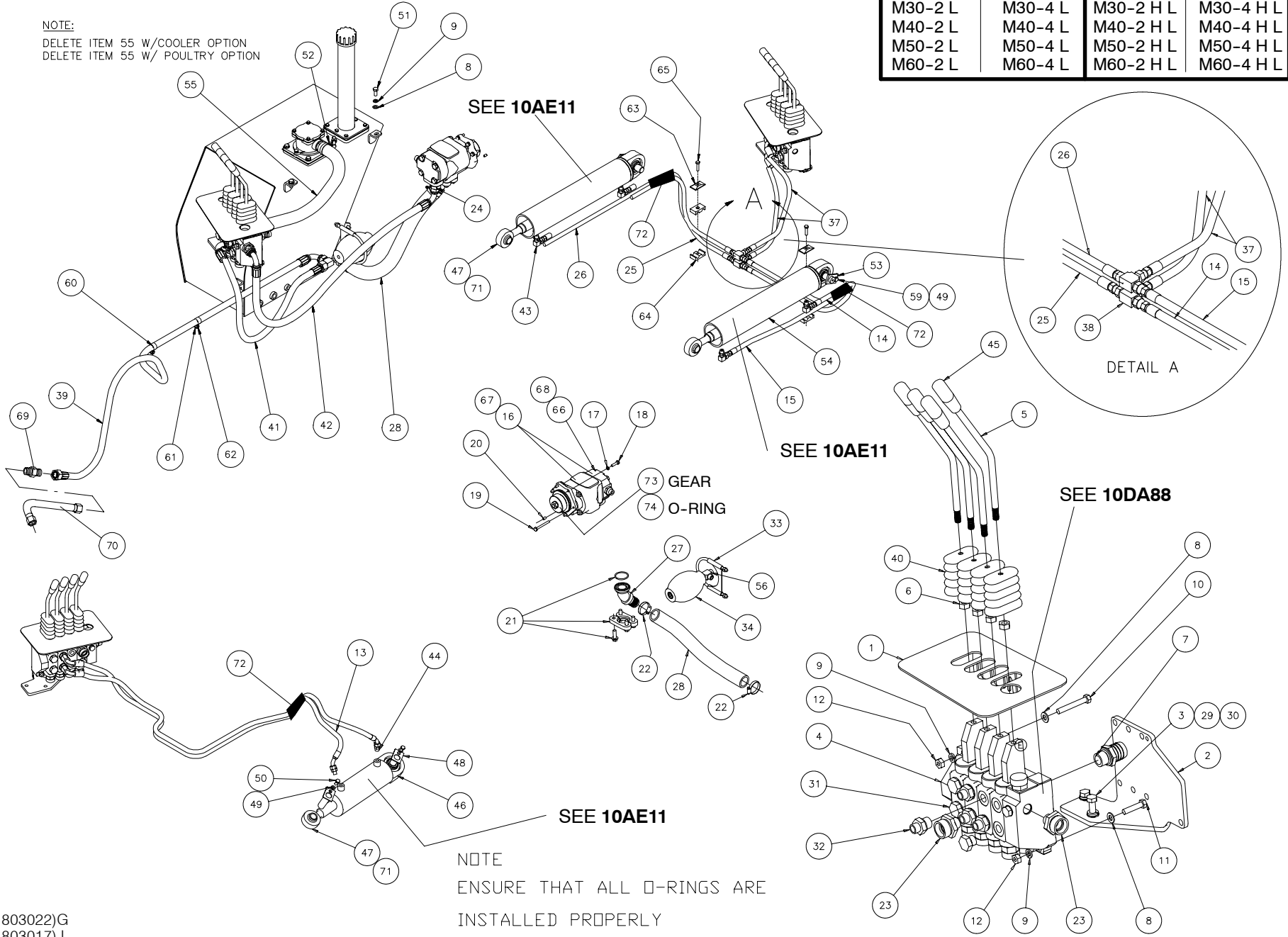

1	HYDRAULIC SYSTEM, PUMP AND CONTROLS		QUANTITY / MODEL											10 AE 10				
			M30-4	M40-4	M50-4	M60-4	M30-4 H	M40-4 H	M50-4 H	M60-4 H	M30-4 L	M40-4 L	M50-4 L	M60-4 L	M30-4 H L	M40-4 H L	M50-4 H L	M60-4 H L
ITEM	PART NO.	DESCRIPTION	M30-2	M40-2	M50-2	M60-2	M30-2 H	M40-2 H	M50-2 H	M60-2 H	M30-2 L	M40-2 L	M50-2 L	M60-2 L	M30-2 H L	M40-2 H L	M50-2 H L	M60-2 H L
1A	803338	Valve cover bracket (100 IN. CAB ONLY - shown)	1	1	1	1	1	1	1	1	1	1	1	1	1	1	1	1
1B	803328	Valve cover bracket (81 & 77 IN. CAB ONLY - not shown)	1	1	1	1	1	1	1	1	1	1	1	1	1	1	1	1
2A	803337	Valve mount bracket (100 IN. CAB ONLY - shown)	1	1	1	1	1	1	1	1	1	1	1	1	1	1	1	1
2B	803326	Valve mount bracket (81 & 77 IN. CAB ONLY - not shown)	1	1	1	1	1	1	1	1	1	1	1	1	1	1	1	1
3	63547	Bolt	2	2	2	2	2	2	2	2	2	2	2	2	2	2	2	2
4	209131	Valve assembly, 4 spool	1	1	1	1	1	1	1	1	1	1	1	1	1	1	1	1
5	801851	Lever, valve	4	4	4	4	4	4	4	4	4	4	4	4	4	4	4	4
6	58548	Nut	4	4	4	4	4	4	4	4	4	4	4	4	4	4	4	4
7	192093	Adapter	1	1	1	1	1	1	1	1	1	1	1	1	1	1	1	1
8	29437	Washer, flat	7	7	7	7	7	7	7	7	7	7	7	7	7	7	7	7
9	42232	Washer, lock	7	7	7	7	7	7	7	7	7	7	7	7	7	7	7	7
10	58538	Bolt	2	2	2	2	2	2	2	2	2	2	2	2	2	2	2	2
11	58536	Bolt	1	1	1	1	1	1	1	1	1	1	1	1	1	1	1	1
12	56354	Nut	3	3	3	3	3	3	3	3	3	3	3	3	3	3	3	3
13	803025	Hose assembly	2	2	2	2	2	2	2	2	2	2	2	2	2	2	2	2
14	803035	Hose assembly	1	1	1	1	1	1	1	1	1	1	1	1	1	1	1	1
15	803034	Hose assembly	1	1	1	1	1	1	1	1	1	1	1	1	1	1	1	1
16	212847	Pump, hydraulic	1	1	1	1	1	1	1	1	1	1	1	1	1	1	1	1
17	42325	Washer, lock	4	4	4	4	4	4	4	4	4	4	4	4	4	4	4	4
18	63754	Bolt	4	4	4	4	4	4	4	4	4	4	4	4	4	4	4	4
19	474011	Bolt	1	1	1	1	1	1	1	1	1	1	1	1	1	1	1	1
20	73191	Screw	1	1	1	1	1	1	1	1	1	1	1	1	1	1	1	1
21	496830	Flange kit	1	1	1	1	1	1	1	1	1	1	1	1	1	1	1	1
22	177274	Clamp, hose	2	2	2	2	2	2	2	2	2	2	2	2	2	2	2	2
23	803031	Adapter	2	2	2	2	2	2	2	2	2	2	2	2	2	2	2	2
24	803032	Adapter	1	1	1	1	1	1	1	1	1	1	1	1	1	1	1	1
25	803037	Hose assembly	1	1	1	1	1	1	1	1	1	1	1	1	1	1	1	1

10 AE 11

MAST TILT CYLINDER ASSEMBLY, 1ST AND 2ND MOUNTING
 MAST SIDE-SHIFT CYLINDER ASSEMBLY, 1ST, 2ND AND 3RD MOUNTING

M30-2 M40-2 M50-2	M30-4 M40-4 M50-4	M30-2 H M40-2 H M50-2 H	M30-4 H M40-4 H M50-4 H
M30-2 L M40-2 L M50-2 L	M30-4 L M40-4 L M50-4 L	M30-2 H L M40-2 H L M50-2 H L	M30-4 H L M40-4 H L M50-4 H L

NOTE:
 FOR 1ST AND 2ND MOUNTINGS OF TILT CYLINDERS, FIND STAMPED ON THE
 BARREL: B5505-1 or 803470-1, B5505-2 or 803470-2, B5505-3 or 803470-3

FOR 1ST, 2ND AND 3RD MOUNTINGS OF SIDE SHIFT CYLINDER, FIND STAMPED
 ON BARREL: B6140-1 or 803827 or MD35006024S-B V10

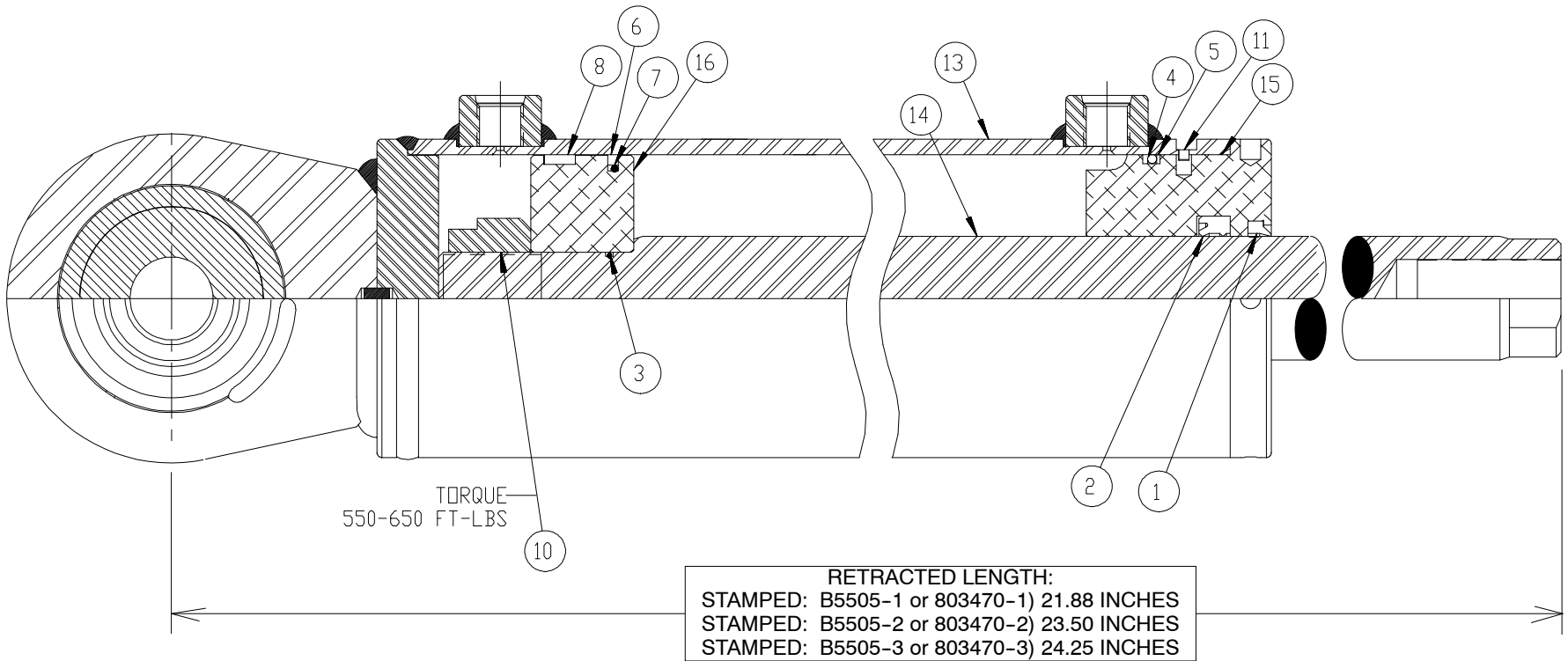

RETRACTED LENGTH:
 STAMPED: B5505-1 or 803470-1) 21.88 INCHES
 STAMPED: B5505-2 or 803470-2) 23.50 INCHES
 STAMPED: B5505-3 or 803470-3) 24.25 INCHES

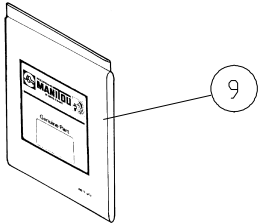

1	MAST TILT CYLINDER ASSEMBLY, 1ST AND 2ND MOUNTING MAST SIDE-SHIFT CYLINDER ASSEMBLY, 1ST, 2ND AND 3RD MOUNTING		QUANTITY / MODEL									10 AE 11					
			M30-4	M40-4	M50-4		M30-4 H	M40-4 H	M50-4 H		M30-4 L	M40-4 L	M50-4 L		M30-4 H L	M40-4 H L	M50-4 H L
			M30-2	M40-2	M50-2		M30-2 H	M40-2 H	M50-2 H		M30-2 L	M40-2 L	M50-2 L		M30-2 H L	M40-2 H L	M50-2 H L
ITEM	PART NO.	DESCRIPTION	M30-2	M40-2	M50-2		M30-2 H	M40-2 H	M50-2 H		M30-2 L	M40-2 L	M50-2 L		M30-2 H L	M40-2 H L	M50-2 H L
	As stamped	Tilt Cyl. Asy, 20°/15° Tilt (Stamped B5505-1 or 803470-1)	2	2	2		2	2	2		2	2	2		2	2	2
	As stamped	Tilt Cyl. Asy, 20°/10° Tilt (Stamped B5505-2 or 803470-2)	2	2	2		2	2	2		2	2	2		2	2	2
	As stamped	Tilt Cyl. Asy, 45°/10° Tilt (Stamped B5505-3 or 803470-3)	2	2	2		2	2	2		2	2	2		2	2	2
	803827	Side Shift Cylinder Assembly (Stamped B6140-1)	1	1	1		1	1	1		1	1	1		1	1	1
1*	803818	Wiper	1	1	1		1	1	1		1	1	1		1	1	1
2*	803817	Seal, rod	1	1	1		1	1	1		1	1	1		1	1	1
3*	803820	O-Ring	1	1	1		1	1	1		1	1	1		1	1	1
4*	803821	O-Ring	1	1	1		1	1	1		1	1	1		1	1	1
5*	803822	Back-up Ring	1	1	1		1	1	1		1	1	1		1	1	1
6*	803823	Cap seal	1	1	1		1	1	1		1	1	1		1	1	1
7*	803824	O-Ring	1	1	1		1	1	1		1	1	1		1	1	1
8	803825	Wear ring	1	1	1		1	1	1		1	1	1		1	1	1
9	803470KIT	Seal Kit (for all Cylinders noted, not all parts will be used)	1	1	1		1	1	1		1	1	1		1	1	1
10	803841	Locknut	1	1	1		1	1	1		1	1	1		1	1	1
11	803840	Retaining ring	1	1	1		1	1	1		1	1	1		1	1	1
13	803859	Barrel, Tilt Cylinder, 20°/15° Tilt	1	1	1		1	1	1		1	1	1		1	1	1
13	803857	Barrel, Tilt Cylinder, 20°/10° Tilt	1	1	1		1	1	1		1	1	1		1	1	1
13	803861	Barrel, Tilt Cylinder, 45°/10° Tilt	1	1	1		1	1	1		1	1	1		1	1	1
13	803845	Barrel, Side Shift	1	1	1		1	1	1		1	1	1		1	1	1
14	803860	Rod, Tilt Cylinder, 20°/15° Tilt	1	1	1		1	1	1		1	1	1		1	1	1
14	803858	Rod, Tilt Cylinder, 20°/10° Tilt	1	1	1		1	1	1		1	1	1		1	1	1
14	803862	Rod, Tilt Cylinder, 45°/10° Tilt	1	1	1		1	1	1		1	1	1		1	1	1
14	803844	Rod, Side Shift Cylinder	1	1	1		1	1	1		1	1	1		1	1	1
15	803856	Head, tilt cylinder	1	1	1		1	1	1		1	1	1		1	1	1
15	803843	Head, side shift cylinder	1	1	1		1	1	1		1	1	1		1	1	1
16	803855	Piston, tilt cylinder	1	1	1		1	1	1		1	1	1		1	1	1
16	803842	Piston, side shift cylinder	1	1	1		1	1	1		1	1	1		1	1	1

* Included in Seal Kit (Item 9).

MAST TILT CYLINDER ASSEMBLY,
3RD MOUNTING

M30-2 M40-2 M50-2	M30-4 M40-4 M50-4	M30-2 H M40-2 H M50-2 H	M30-4 H M40-4 H M50-4 H
M30-2 L M40-2 L M50-2 L	M30-4 L M40-4 L M50-4 L	M30-2 H L M40-2 H L M50-2 H L	M30-4 H L M40-4 H L M50-4 H L

**NOTE:
FOR 3RD MOUNTING OF TILT CYLINDER,
FIND STAMPED ON THE BARREL: "AM&H"**

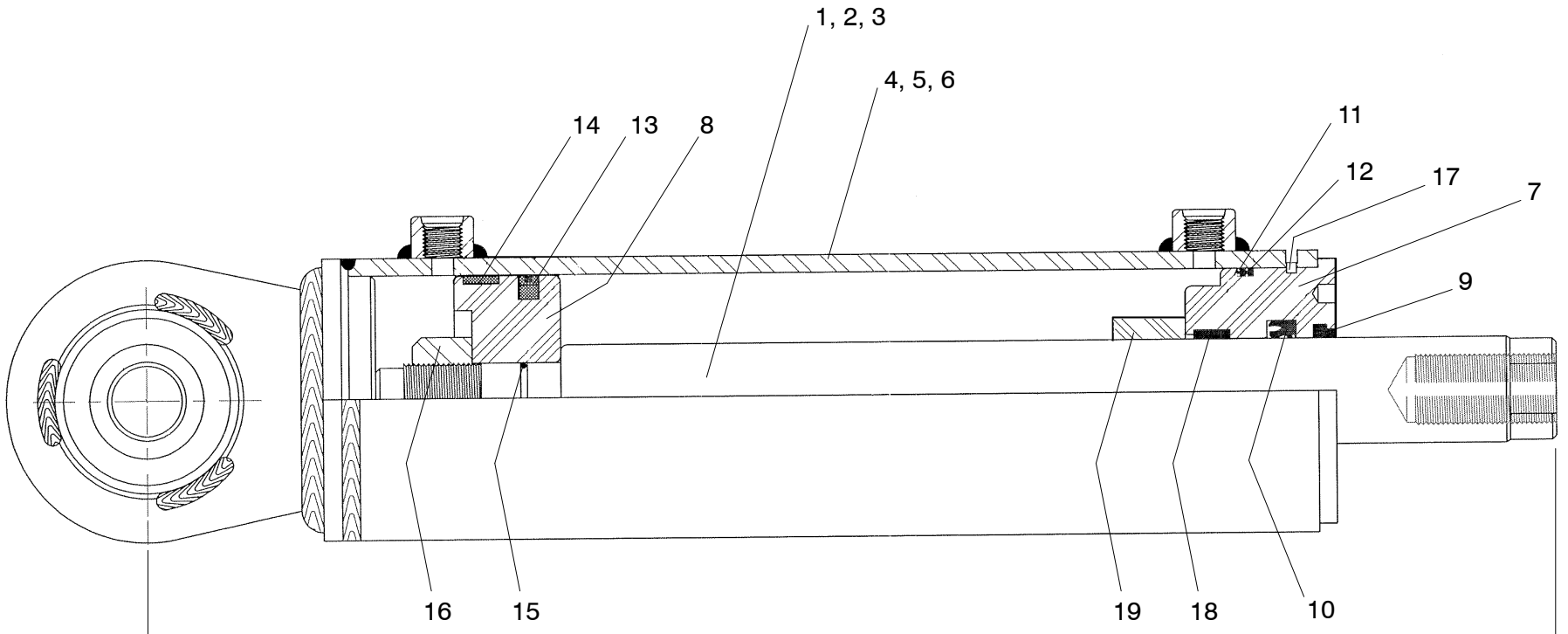

RETRACTED LENGTH:
Item 21) 803470-1) 21.88 INCHES
Item 22) 803470-2) 23.50 INCHES
Item 23) 803470-3) 24.25 INCHES

1	MAST TILT CYLINDER ASSEMBLY, 3RD MOUNTING												QUANTITY / MODEL					
	ITEM	PART NO.	DESCRIPTION	M30-2	M40-2	M50-2		M30-2 H	M40-2 H	M50-2 H		M30-2 L	M40-2 L	M50-2 L		M30-4 H L	M40-4 H L	M50-4 H L
1	806883	Rod, Tilt Cylinder, 20°/15° Tilt	1	1	1	1	1	1	1	1	1	1	1	1	1	1	1	1
2	806885	Rod, Tilt Cylinder, 20°/10° Tilt	1	1	1	1	1	1	1	1	1	1	1	1	1	1	1	1
3	807151	Rod, Tilt Cylinder, 45°/10° Tilt	1	1	1	1	1	1	1	1	1	1	1	1	1	1	1	1
4	806884	Barrel, Tilt Cylinder, 20°/15° Tilt	1	1	1	1	1	1	1	1	1	1	1	1	1	1	1	1
5	807150	Barrel, Tilt Cylinder, 20°/10° Tilt	1	1	1	1	1	1	1	1	1	1	1	1	1	1	1	1
6	806886	Barrel, Tilt Cylinder, 45°/10° Tilt	1	1	1	1	1	1	1	1	1	1	1	1	1	1	1	1
7	806887	Gland	1	1	1	1	1	1	1	1	1	1	1	1	1	1	1	1
8	806888	Piston	1	1	1	1	1	1	1	1	1	1	1	1	1	1	1	1
9*	806889	Wiper, rod	1	1	1	1	1	1	1	1	1	1	1	1	1	1	1	1
10*	806890	Seal, rod	1	1	1	1	1	1	1	1	1	1	1	1	1	1	1	1
11*	806891	O-Ring	1	1	1	1	1	1	1	1	1	1	1	1	1	1	1	1
12*	806892	Back-up Ring	1	1	1	1	1	1	1	1	1	1	1	1	1	1	1	1
13*	806893	Seal, piston	1	1	1	1	1	1	1	1	1	1	1	1	1	1	1	1
14	806894	Wear ring	1	1	1	1	1	1	1	1	1	1	1	1	1	1	1	1
15*	806895	O-Ring	1	1	1	1	1	1	1	1	1	1	1	1	1	1	1	1
16	806896	Locknut	1	1	1	1	1	1	1	1	1	1	1	1	1	1	1	1
17	806897	Lockwire	1	1	1	1	1	1	1	1	1	1	1	1	1	1	1	1
18	806898	Wear ring	1	1	1	1	1	1	1	1	1	1	1	1	1	1	1	1
19	B5521-6	Spacer (for Tilt Cylinder 803470-3)	1	1	1	1	1	1	1	1	1	1	1	1	1	1	1	1
20	803470KIT	Seal Kit (for all Cylinders noted, not all parts will be used)	1	1	1	1	1	1	1	1	1	1	1	1	1	1	1	1
21**	803470-1	Tilt Cylinder Assembly, 20°/15° Tilt (Stamped AM&H)	2	2	2	2	2	2	2	2	2	2	2	2	2	2	2	2
22**	803470-2	Tilt Cylinder Assembly, 20°/10° Tilt (Stamped AM&H)	2	2	2	2	2	2	2	2	2	2	2	2	2	2	2	2
23**	803470-3	Tilt Cylinder Assembly, 45°/10° Tilt (Stamped AM&H)	2	2	2	2	2	2	2	2	2	2	2	2	2	2	2	2

* Items included in Seal Kit (Item 20).

** Measure RETRACTED LENGTH to determine
Cylinder Assembly Part Number.

10 AF 10

HYDRAULIC DIFFERENTIAL LOCKING ASSEMBLY

M30-2	M30-4	M30-2 H	M30-4 H
M40-2	M40-4	M40-2 H	M40-4 H
M50-2	M50-4	M50-2 H	M50-4 H
M60-2	M60-4	M60-2 H	M60-4 H
M30-2 L	M30-4 L	M30-2 H L	M30-4 H L
M40-2 L	M40-4 L	M40-2 H L	M40-4 H L
M50-2 L	M50-4 L	M50-2 H L	M50-4 H L
M60-2 L	M60-4 L	M60-2 H L	M60-4 H L

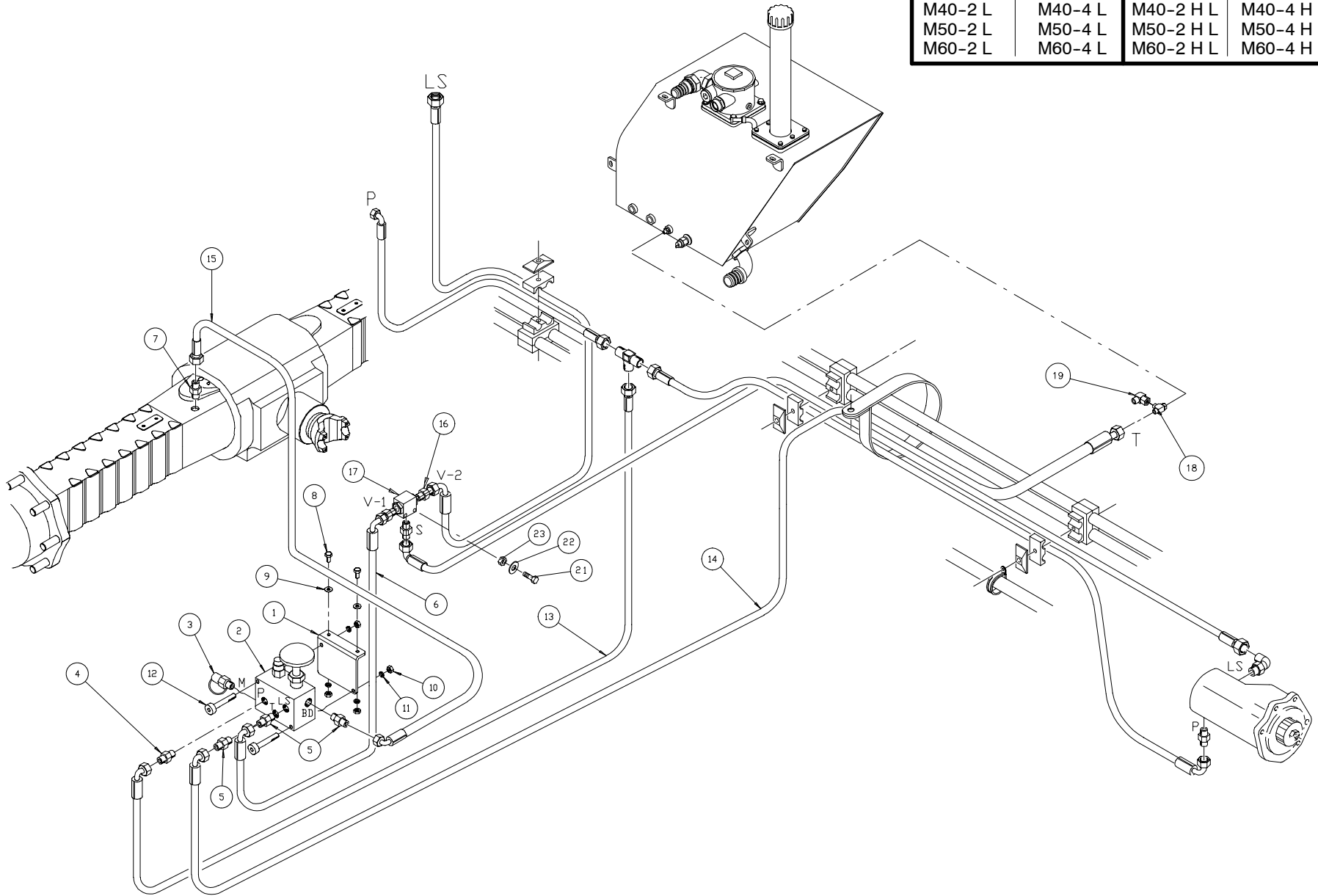

1	HYDRAULIC DIFFERENTIAL LOCKING ASSEMBLY		QUANTITY / MODEL											10 AF 10				
			M30-4	M40-4	M50-4	M60-4	M30-4 H	M40-4 H	M50-4 H	M60-4 H	M30-4 L	M40-4 L	M50-4 L	M60-4 L	M30-4 H L	M40-4 H L	M50-4 H L	M60-4 H L
ITEM	PART NO.	DESCRIPTION	M30-2	M40-2	M50-2	M60-2	M30-2 H	M40-2 H	M50-2 H	M60-2 H	M30-2 L	M40-2 L	M50-2 L	M60-2 L	M30-2 H L	M40-2 H L	M50-2 H L	M60-2 H L
1	802983	Bracket, valve mount	1	1	1	1	1	1	1	1	1	1	1	1	1	1	1	1
2	240077	Valve	1	1	1	1	1	1	1	1	1	1	1	1	1	1	1	1
3	72339	Fitting, pressure test	1	1	1	1	1	1	1	1	1	1	1	1	1	1	1	1
4	803177	Connector	1	1	1	1	1	1	1	1	1	1	1	1	1	1	1	1
5	803196	Connector	3	3	3	3	3	3	3	3	3	3	3	3	3	3	3	3
6	803021	Hose assembly	1	1	1	1	1	1	1	1	1	1	1	1	1	1	1	1
7	803182	Connector	1	1	1	1	1	1	1	1	1	1	1	1	1	1	1	1
8	25713	Bolt	2	2	2	2	2	2	2	2	2	2	2	2	2	2	2	2
9	174132	Washer, lock	2	2	2	2	2	2	2	2	2	2	2	2	2	2	2	2
10	25714	Nut	4	4	4	4	4	4	4	4	4	4	4	4	4	4	4	4
11	42316	Washer, lock	4	4	4	4	4	4	4	4	4	4	4	4	4	4	4	4
12	178696	Bolt	2	2	2	2	2	2	2	2	2	2	2	2	2	2	2	2
13	803019	Hose assembly	1	1	1	1	1	1	1	1	1	1	1	1	1	1	1	1
14	803200	Hose assembly	1	1	1	1	1	1	1	1	1	1	1	1	1	1	1	1
15	803020	Hose assembly	1	1	1	1	1	1	1	1	1	1	1	1	1	1	1	1
16	803184	Connector	3	3	3	3	3	3	3	3	3	3	3	3	3	3	3	3
17	480079	Valve, flip flop	1	1	1	1	1	1	1	1	1	1	1	1	1	1	1	1
18	803198	Union tee	1	1	1	1	1	1	1	1	1	1	1	1	1	1	1	1
19	803199	Elbow, swivel nut	1	1	1	1	1	1	1	1	1	1	1	1	1	1	1	1
20	B4712	Decal, diff. lock	1	1	1	1	1	1	1	1	1	1	1	1	1	1	1	1
21	K300858	Bolt	2	2	2	2	2	2	2	2	2	2	2	2	2	2	2	2
22	K34805	Washer	2	2	2	2	2	2	2	2	2	2	2	2	2	2	2	2
23	K33795	Nut	2	2	2	2	2	2	2	2	2	2	2	2	2	2	2	2

10 BA 10

STEERING HYDRAULICS, 2WD AND 4WD

M30-2	M30-4	M30-2 H	M30-4 H
M40-2	M40-4	M40-2 H	M40-4 H
M50-2	M50-4	M50-2 H	M50-4 H
M60-2	M60-4	M60-2 H	M60-4 H
M30-2 L	M30-4 L	M30-2 H L	M30-4 H L
M40-2 L	M40-4 L	M40-2 H L	M40-4 H L
M50-2 L	M50-4 L	M50-2 H L	M50-4 H L
M60-2 L	M60-4 L	M60-2 H L	M60-4 H L

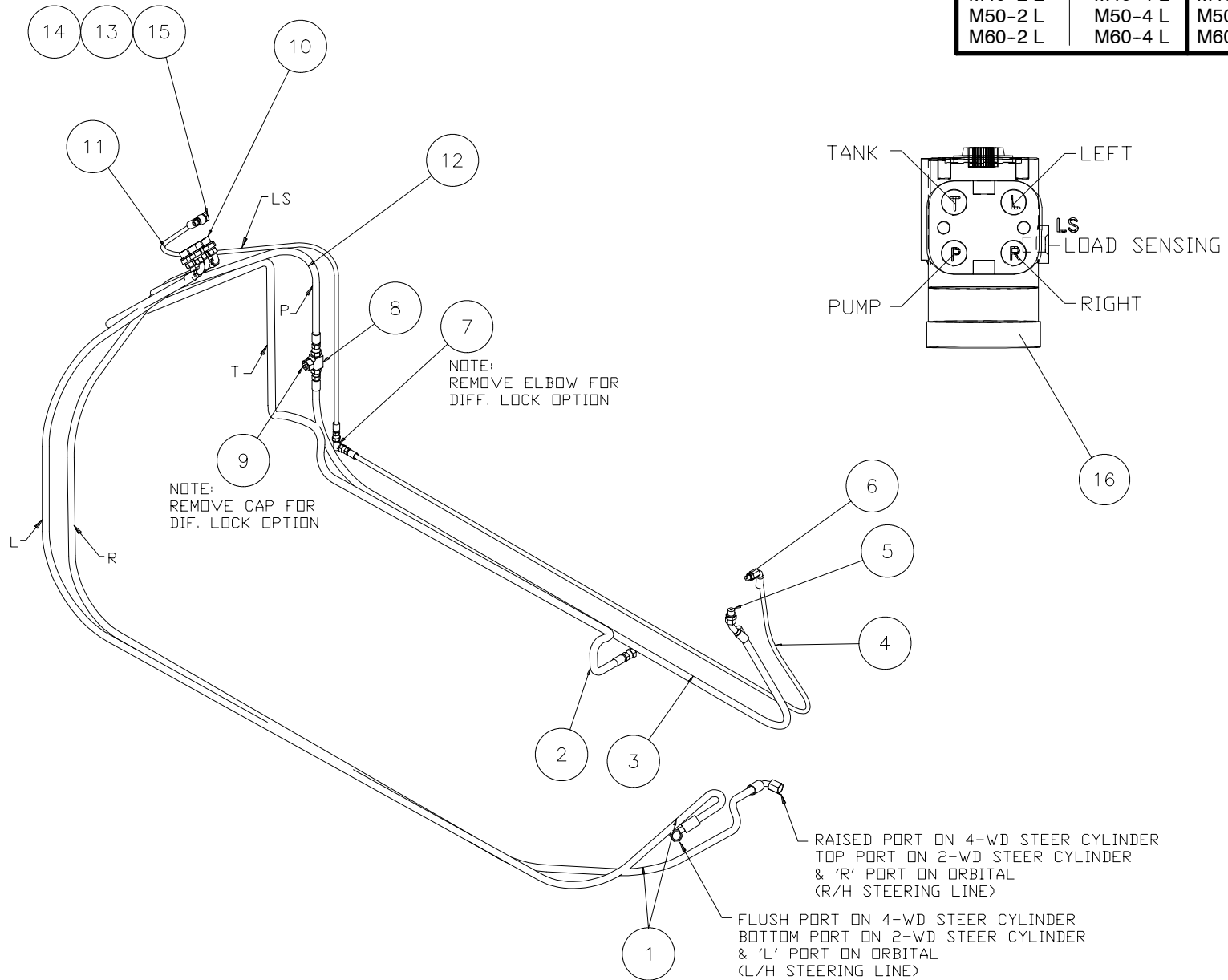

1	STEERING HYDRAULICS, 2WD AND 4WD		QUANTITY / MODEL												10 BA 10			
			M30-4	M40-4	M50-4	M60-4	M30-4 H	M40-4 H	M50-4 H	M60-4 H	M30-4 L	M40-4 L	M50-4 L	M60-4 L	M30-4 H L	M40-4 H L	M50-4 H L	M60-4 H L
ITEM	PART NO.	DESCRIPTION	M30-2	M40-2	M50-2	M60-2	M30-2 H	M40-2 H	M50-2 H	M60-2 H	M30-2 L	M40-2 L	M50-2 L	M60-2 L	M30-2 H L	M40-2 H L	M50-2 H L	M60-2 H L
1	803187	Hose assembly	2	2	2	2	2	2	2	2	2	2	2	2	2	2	2	2
2	803189	Hose assembly	1	1	1	1	1	1	1	1	1	1	1	1	1	1	1	1
3	803191	Hose assembly	1	1	1	1	1	1	1	1	1	1	1	1	1	1	1	1
4	803192	Hose assembly	1	1	1	1	1	1	1	1	1	1	1	1	1	1	1	1
5	803177	Connector	1	1	1	1	1	1	1	1	1	1	1	1	1	1	1	1
6	803184	Connector	1	1	1	1	1	1	1	1	1	1	1	1	1	1	1	1
7	803193	Elbow	1	1	1	1	1	1	1	1	1	1	1	1	1	1	1	1
8	803030	Tee	1	1	1	1	1	1	1	1	1	1	1	1	1	1	1	1
9	R19872-6	Cap	1	1	1	1	1	1	1	1	1	1	1	1	1	1	1	1
10	803188	Connector	4	4	4	4	4	4	4	4	4	4	4	4	4	4	4	4
11	803194	Hose assembly	1	1	1	1	1	1	1	1	1	1	1	1	1	1	1	1
12	803190	Hose assembly	1	1	1	1	1	1	1	1	1	1	1	1	1	1	1	1
13	479275	Seal, copper	3	3	3	3	3	3	3	3	3	3	3	3	3	3	3	3
14	207785	Spacer	1	1	1	1	1	1	1	1	1	1	1	1	1	1	1	1
15	207784	Screw, hollow	1	1	1	1	1	1	1	1	1	1	1	1	1	1	1	1
16	197335	Steering orbital	1	1	1	1	1	1	1	1	1	1	1	1	1	1	1	1

10 CE 15

STEERING CYLINDER, 2WD

M30-2	M30-4	M30-2 H	M30-4 H
M40-2	M40-4	M40-2 H	M40-4 H
M50-2	M50-4	M50-2 H	M50-4 H
M60-2	M60-4	M60-2 H	M60-4 H
M30-2 L	M30-4 L	M30-2 H L	M30-4 H L
M40-2 L	M40-4 L	M40-2 H L	M40-4 H L
M50-2 L	M50-4 L	M50-2 H L	M50-4 H L
M60-2 L	M60-4 L	M60-2 H L	M60-4 H L

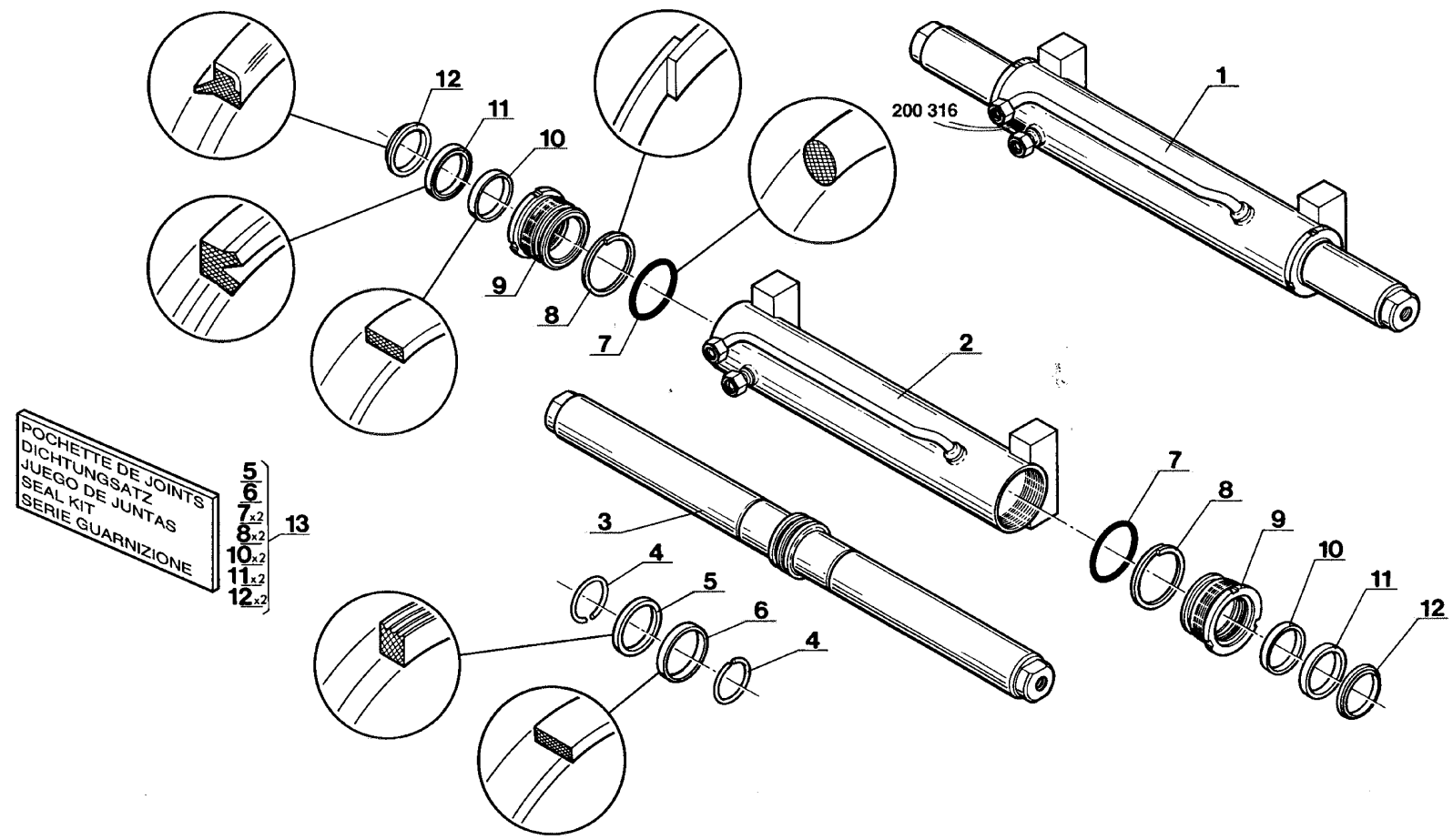
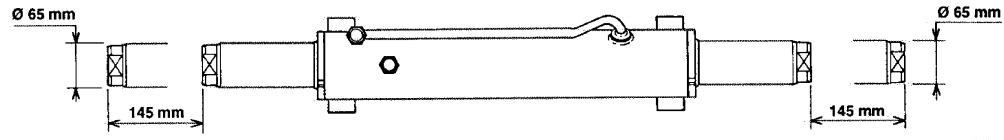

POCHETTE DE JOINTS
 DICHTUNGSATZ
 JUEGO DE JUNTAS
 SEAL KIT
 SERIE GUARNIZIONE

5
 6
 7_{x2}
 8_{x2}
 10_{x2}
 11_{x2}
 12_{x2}

13

1	STEERING CYLINDER, 2WD		QUANTITY / MODEL												10 CE 15			
			M30-2	M40-2	M50-2	M60-2	M30-2 H	M40-2 H	M50-2 H	M60-2 H	M30-2 L	M40-2 L	M50-2 L	M60-2 L	M30-2 H L	M40-2 H L	M50-2 H L	M60-2 H L
ITEM	PART NO.	DESCRIPTION	M30-2	M40-2	M50-2	M60-2	M30-2 H	M40-2 H	M50-2 H	M60-2 H	M30-2 L	M40-2 L	M50-2 L	M60-2 L	M30-2 H L	M40-2 H L	M50-2 H L	M60-2 H L
1	200316	Steering cylinder, complete 2WD	1	1	1	1	1	1	1	1	1	1	1	1	1	1	1	1
2	561637	Cylinder body	1	1	1	1	1	1	1	1	1	1	1	1	1	1	1	1
3	561623	Cylinder rod	1	1	1	1	1	1	1	1	1	1	1	1	1	1	1	1
4	197670	Snap ring	2	2	2	2	2	2	2	2	2	2	2	2	2	2	2	2
5	561624	Seal	1	1	1	1	1	1	1	1	1	1	1	1	1	1	1	1
6	561625	Seal	1	1	1	1	1	1	1	1	1	1	1	1	1	1	1	1
7	5239	O-ring	2	2	2	2	2	2	2	2	2	2	2	2	2	2	2	2
8	187898	Seal, anti-extrusion	2	2	2	2	2	2	2	2	2	2	2	2	2	2	2	2
9	561622	Fastening ring	2	2	2	2	2	2	2	2	2	2	2	2	2	2	2	2
10	561621	Guide ring	2	2	2	2	2	2	2	2	2	2	2	2	2	2	2	2
11	561620	Seal	2	2	2	2	2	2	2	2	2	2	2	2	2	2	2	2
12	197709	Seal	2	2	2	2	2	2	2	2	2	2	2	2	2	2	2	2
13	551774	Seal kit	1	1	1	1	1	1	1	1	1	1	1	1	1	1	1	1

10 DA 88

HYDRAULIC VALVE BANK ASSEMBLY

M30-2	M30-4	M30-2 H	M30-4 H
M40-2	M40-4	M40-2 H	M40-4 H
M50-2	M50-4	M50-2 H	M50-4 H
M60-2	M60-4	M60-2 H	M60-4 H
M30-2 L	M30-4 L	M30-2 H L	M30-4 H L
M40-2 L	M40-4 L	M40-2 H L	M40-4 H L
M50-2 L	M50-4 L	M50-2 H L	M50-4 H L
M60-2 L	M60-4 L	M60-2 H L	M60-4 H L

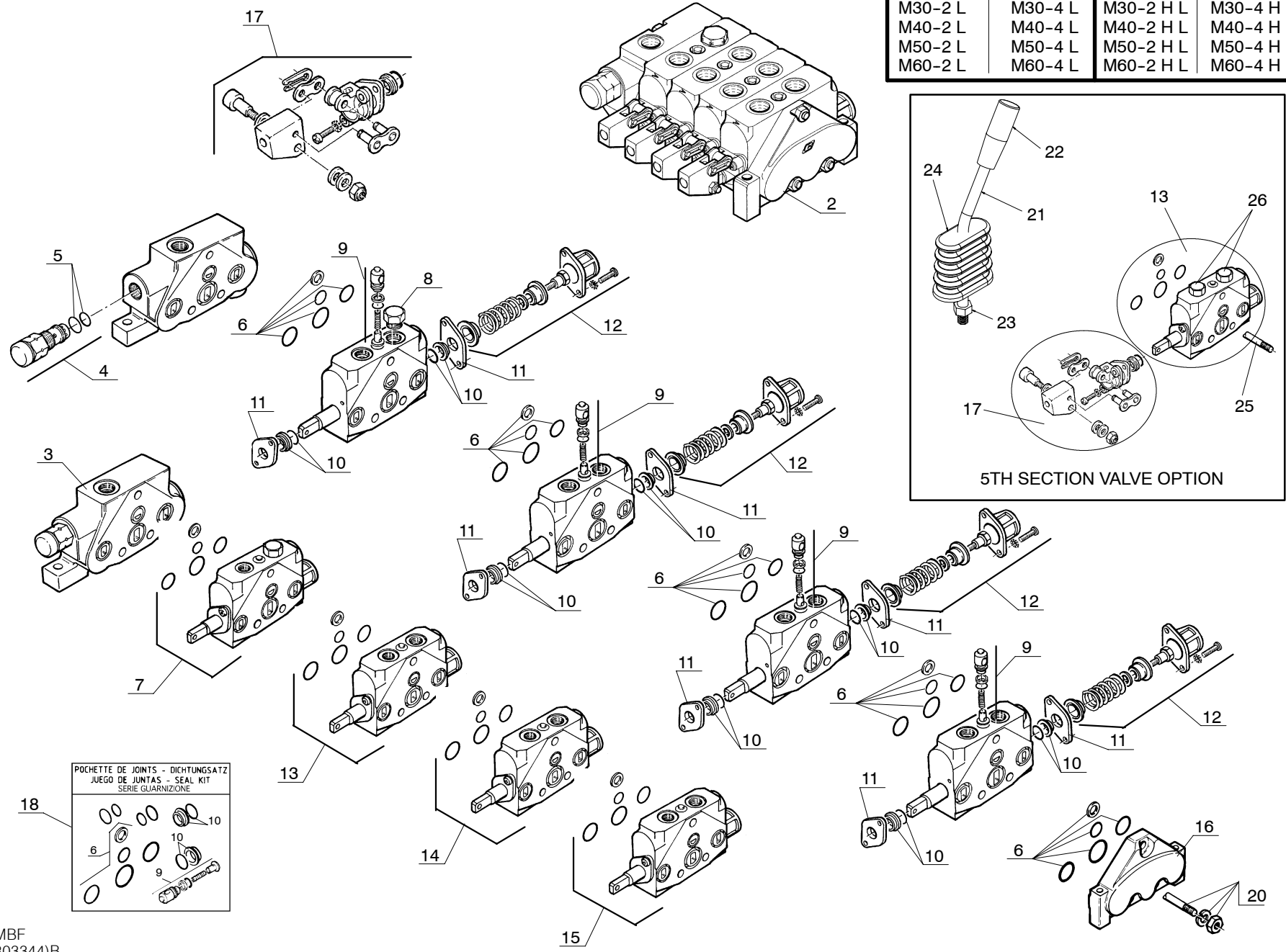

POCHETTE DE JOINTS - DICHTUNGSATZ
 JUEGO DE JUNTAS - SEAL KIT
 SERIE GUARNIZIONE

5TH SECTION VALVE OPTION

1	HYDRAULIC VALVE BANK ASSEMBLY		QUANTITY / MODEL											10 DA 88				
			M30-4	M40-4	M50-4	M60-4	M30-4 H	M40-4 H	M50-4 H	M60-4 H	M30-4 L	M40-4 L	M50-4 L	M60-4 L	M30-4 H L	M40-4 H L	M50-4 H L	M60-4 H L
ITEM	PART NO.	DESCRIPTION	M30-2	M40-2	M50-2	M60-2	M30-2 H	M40-2 H	M50-2 H	M60-2 H	M30-2 L	M40-2 L	M50-2 L	M60-2 L	M30-2 H L	M40-2 H L	M50-2 H L	M60-2 H L
2	209131	Valve bank assembly	1	1	1	1	1	1	1	1	1	1	1	1	1	1	1	1
3	551239	Inlet member	1	1	1	1	1	1	1	1	1	1	1	1	1	1	1	1
4	548112	Relief valve	1	1	1	1	1	1	1	1	1	1	1	1	1	1	1	1
5	476318	O-ring	A/R	A/R	A/R	A/R	A/R	A/R	A/R	A/R	A/R	A/R	A/R	A/R	A/R	A/R	A/R	A/R
6	476321	Seal	A/R	A/R	A/R	A/R	A/R	A/R	A/R	A/R	A/R	A/R	A/R	A/R	A/R	A/R	A/R	A/R
7	561340	Single acting member	1	1	1	1	1	1	1	1	1	1	1	1	1	1	1	1
8	476341	Plug	1	1	1	1	1	1	1	1	1	1	1	1	1	1	1	1
9	476322	Valve	A/R	A/R	A/R	A/R	A/R	A/R	A/R	A/R	A/R	A/R	A/R	A/R	A/R	A/R	A/R	A/R
10	476324	Seal	A/R	A/R	A/R	A/R	A/R	A/R	A/R	A/R	A/R	A/R	A/R	A/R	A/R	A/R	A/R	A/R
11	476325	Plate	A/R	A/R	A/R	A/R	A/R	A/R	A/R	A/R	A/R	A/R	A/R	A/R	A/R	A/R	A/R	A/R
12	548894	Spring return drive	A/R	A/R	A/R	A/R	A/R	A/R	A/R	A/R	A/R	A/R	A/R	A/R	A/R	A/R	A/R	A/R
13	476850	Double acting member	1	1	1	1	1	1	1	1	1	1	1	1	1	1	1	1
14	476850	Double acting member	1	1	1	1	1	1	1	1	1	1	1	1	1	1	1	1
15	476850	Double acting member	1	1	1	1	1	1	1	1	1	1	1	1	1	1	1	1
16	549774	Fastening member	1	1	1	1	1	1	1	1	1	1	1	1	1	1	1	1
17	549672	Single drive	A/R	A/R	A/R	A/R	A/R	A/R	A/R	A/R	A/R	A/R	A/R	A/R	A/R	A/R	A/R	A/R
18	192871	Seal kit	A/R	A/R	A/R	A/R	A/R	A/R	A/R	A/R	A/R	A/R	A/R	A/R	A/R	A/R	A/R	A/R
20	600726	Tie rod	1	1	1	1	1	1	1	1	1	1	1	1	1	1	1	1
21	801851	Lever, valve	1	1	1	1	1	1	1	1	1	1	1	1	1	1	1	1
22	202226	Handle, valve	1	1	1	1	1	1	1	1	1	1	1	1	1	1	1	1
23	58548	Nut	1	1	1	1	1	1	1	1	1	1	1	1	1	1	1	1
24	199728	Boot, single lever	1	1	1	1	1	1	1	1	1	1	1	1	1	1	1	1
25	600753	Tie rod	3	3	3	3	3	3	3	3	3	3	3	3	3	3	3	3
26	175743	Plug	2	2	2	2	2	2	2	2	2	2	2	2	2	2	2	2

11 AA 10

ELECTRICAL ASSEMBLY (FUSES), 4-SPEED

802134)Q

POULTRY TRUCKS - S/N: 750455 & BELOW COMMERCIAL TRUCKS - ALL

M30-2	M30-4
M40-2	M40-4
M50-2	M50-4
M60-2	M60-4

M30-2 L	M30-4 L
M40-2 L	M40-4 L
M50-2 L	M50-4 L
M60-2 L	M60-4 L

"CONNECTORS - AS SEEN FROM THE BACK"

NOTE:

- 1) DO NOT PAINT NEGATIVE GROUND BOLT
- 2) PROTECT BATTERY TERMINALS WITH ANTI-RUST
- 3) WIRES MUST NOT TOUCH SHARP EDGES AND CORNERS AND DR SHEET METAL

LEGEND:

- VI - VIOLET
- BC - WHITE
- RD - PINK
- R - RED
- N - BLACK
- J - YELLOW
- V - GREEN
- M - BROWN
- BL - BLUE
- O - ORANGE
- G - GRAY

FUSE BOX IDENTIFICATION

- | | |
|-------------------------------------|---------|
| 01 - ROAD LIGHT OPTION LEVER (15A) | Rep:116 |
| 02 - WARNING (10A) | Rep:115 |
| 03 - REAR WIPER OPTION (7.5A) | Rep:114 |
| 04 - REAR MBF CAB WORK LIGHTS (10A) | Rep: |
| 05 - WORK LIGHTS (10A) | Rep: |
| 06 - HEATER OPTION (15A) | Rep:116 |
| 07 - DASH PANEL (5A) | Rep:113 |
| 08 - FRONT WIPER (10A) | Rep:115 |
| 09 - FLASHER UNIT (10A) | Rep:115 |
| 10 - SHUTTLE LEVER (10A) | Rep:115 |
| 11 - HORN / BRAKE LIGHTS (10A) | Rep:115 |
| 12 - BEACON OPTION(7.5A) | Rep:114 |
| 13 - TAIL LIGHT RIGHT OPTION (5A) | Rep:113 |
| 14 - TAIL LIGHT LEFT OPTION(5A) | Rep:113 |
| 15 - RIGHT TURN SIGNAL OPTION(7.5A) | Rep:114 |
| 16 - LEFT TURN SIGNAL OPTION(7.5A) | Rep:114 |
| 17 - LOW BEAM OPTION (10A) | Rep:115 |
| 18 - HIGH BEAM OPTIN (10A) | Rep:115 |
| 19 - DOME LIGHT OPTION (3A) | Rep:112 |
| 20 - FRAME LEVEL (5A) | Rep: |
| 21 - GAUGES / ENGINE SHUTDOWN (5A) | Rep: |
| 22 - AXLE COOLER (10A) | Rep: |
| 23 - AXLE COOLER (10A) | Rep: |
| 24 - 2WD / 4WD SELECTOR (7.5A) | Rep:114 |
| 25 - ENGINE PREHEAT(20A) | Rep:118 |

**804040 FUSE BREAKER OPTION (POULTRY ONLY)
- INSTALLATION OF BREAKER HARNESS 803422 REQUIRED -**

- 1 - 803748 COVER, FUSE BOX
- 2 - 184088 SCREW, M5
- 2 - 28060 WASHER, M5
- 2 - 84232 NUT, M5
- 10 - 804037 CIRCUIT BREAKER 10 AMP
- 2 - 804038 CIRCUIT BREAKER 15 AMP

COVER ALL FUSE TERMINALS WITH DIELECTRIC GREASE

FUSE QTY WILL NOT BE EXACT DUE TO OPTION VARIATIONS

- REPLACE FUSE #1 WITH 804038
- REPLACE FUSE #3 WITH 804037 IF EQUIPPED REAR WIPER
- REPLACE FUSE #4 WITH 804037
- REPLACE FUSE #5 WITH 804037
- REPLACE FUSE #6 WITH 804038 IF EQUIPPED HEATER
- REPLACE FUSE #8 WITH 804037 IF EQUIPPED FRONT WIPER
- REPLACE FUSE #10 WITH 804037
- REPLACE FUSE #11 WITH 804037
- REPLACE FUSE #12 WITH 804037 IF EQUIPPED BEACON
- REPLACE FUSE #17 WITH 804037
- REPLACE FUSE #18 WITH 804037
- REPLACE FUSE #22 WITH 804037
- REPLACE FUSE #23 WITH 804037 IF EQUIPPED AXLE COOLER
- REPLACE FUSE #24 WITH 804037 IF EQUIPPED 4WD TORQUE CONVERTER

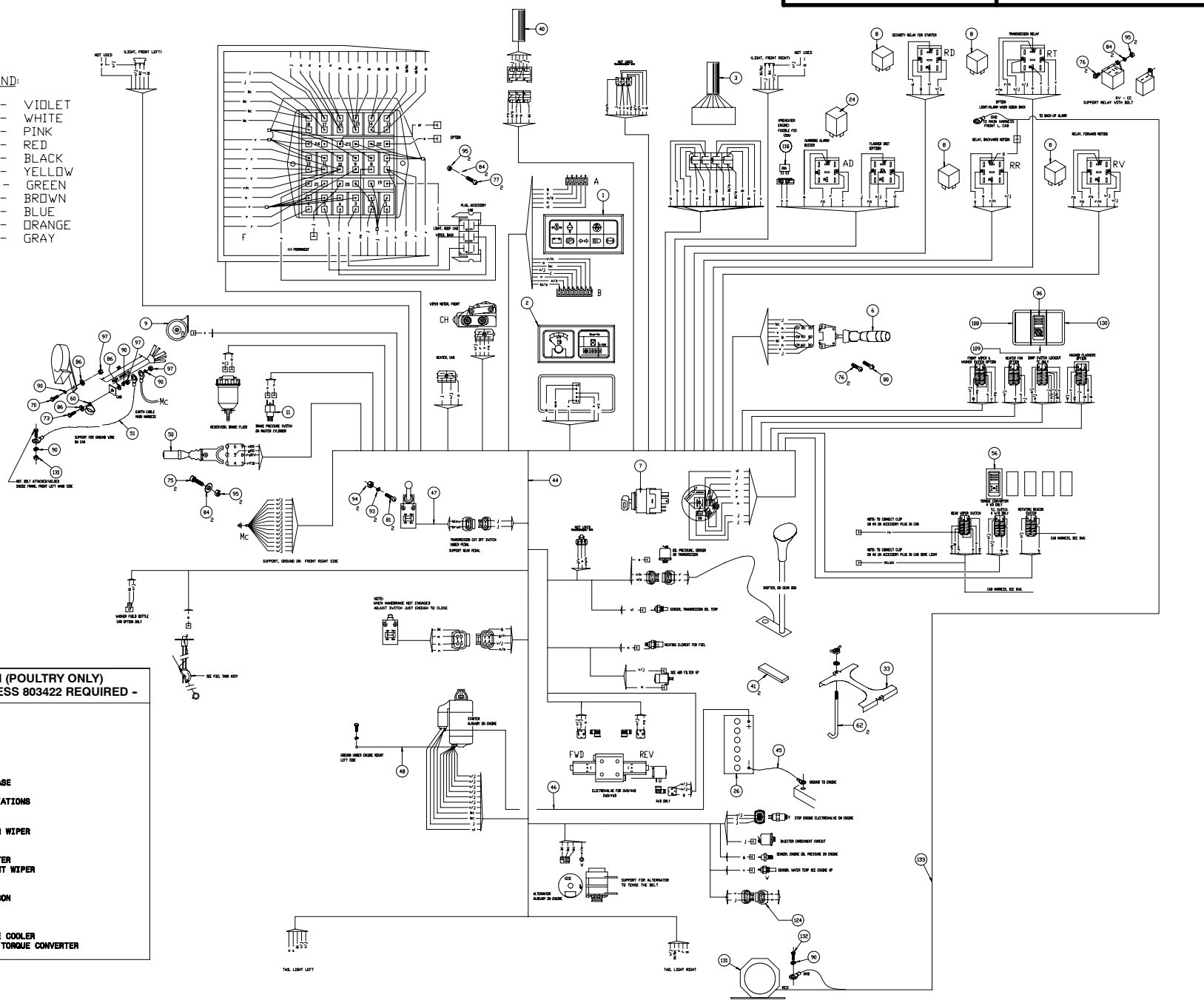

TAIL LIGHT LEFT

TAIL LIGHT RIGHT

BACK UP ALARM

1	ELECTRICAL ASSEMBLY (FUSES), 4-SPEED		QUANTITY / MODEL								11 AA 10							
			M30-4	M40-4	M50-4	M60-4					M30-4 L	M40-4 L	M50-4 L	M60-4 L				
ITEM	PART NO.	DESCRIPTION	M30-2	M40-2	M50-2	M60-2					M30-2 L	M40-2 L	M50-2 L	M60-2 L				
1A	214516	Panel, warning lights - 1st mounting	1	1	1	1					1	1	1	1				
1B	686343	Panel, warning lights - 2nd mounting, replaces 214516	1	1	1	1					1	1	1	1				
2	214517	Panel, hour meter and fuel gauge	1	1	1	1					1	1	1	1				
3	210942	Test module	1	1	1	1					1	1	1	1				
6	191384	Lever, lighting, horn	1	1	1	1					1	1	1	1				
7	184817	Ignition switch	1	1	1	1					1	1	1	1				
8	231243	Relay	4	4	4	4					4	4	4	4				
9	20125	Horn	1	1	1	1					1	1	1	1				
11	79126	Stop switch, brake lights	1	1	1	1					1	1	1	1				
12	562044	Fuse panel	1	1	1	1					1	1	1	1				
13	561322	Fuse box cover	1	1	1	1					1	1	1	1				
24	176737	Buzzer	1	1	1	1					1	1	1	1				
26	- - - -	Purchase locally	1	1	1	1					1	1	1	1				
33	202703	Strap, battery	1	1	1	1					1	1	1	1				
36	224763	Inching enable switch	1	1	1	1					1	1	1	1				
40	223246	Relay, delay	1	1	1	1					1	1	1	1				
41	41077	Strip, rubber	2	2	2	2					2	2	2	2				
44	246700	Wire harness, main	1	1	1	1					1	1	1	1				
45	425023	Cable, negative battery	1	1	1	1					1	1	1	1				
46	802937	Cable, positive battery	1	1	1	1					1	1	1	1				
47	219100	Transmission cut-off switch	1	1	1	1					1	1	1	1				
48	802977	Cable, negative ground	1	1	1	1					1	1	1	1				
50	234956	Shifter, F-N-R	1	1	1	1					1	1	1	1				
51	215875	Earth cable	1	1	1	1					1	1	1	1				

2	ELECTRICAL ASSEMBLY (FUSES), 4-SPEED		QUANTITY / MODEL										11 AA 10					
			M30-4	M40-4	M50-4	M60-4					M30-4 L	M40-4 L	M50-4 L	M60-4 L				
ITEM	PART NO.	DESCRIPTION	M30-2	M40-2	M50-2	M60-2					M30-2 L	M40-2 L	M50-2 L	M60-2 L				
56	238065	2WD / 4WD switch (4WD Models ONLY)	1	1	1	1					1	1	1	1				
60	86506	Clamp	1	1	1	1					1	1	1	1				
61	221391	Horn bracket	1	1	1	1					1	1	1	1				
62	496687	J Hook, wing nut and washer	2	2	2	2					2	2	2	2				
70	54951	Screw	1	1	1	1					1	1	1	1				
71	42347	Screw	1	1	1	1					1	1	1	1				
73	168348	Screw	1	1	1	1					1	1	1	1				
75	5323	Screw	2	2	2	2					2	2	2	2				
76	79533	Screw	10	10	10	10					10	10	10	10				
77	206082	Screw	2	2	2	2					2	2	2	2				
80	192041	Screw	1	1	1	1					1	1	1	1				
81	802986	Screw	2	2	2	2					2	2	2	2				
84	28959	Washer	8	8	8	8					8	8	8	8				
86	61674	Washer	2	2	2	2					2	2	2	2				
90	42325	Washer	7	7	7	7					7	7	7	7				
93	78806	Washer	2	2	2	2					2	2	2	2				
94		Nut	2	2	2	2					2	2	2	2				
95	54232	Nut	9	9	9	9					9	9	9	9				
96	K33799SS	Nut	4	4	4	4					4	4	4	4				
97	58528	Nut	4	4	4	4					4	4	4	4				
99	162229	Nut	6	6	6	6					6	6	6	6				

			QUANTITY / MODEL											11 AA 10				
			M30-4	M40-4	M50-4	M60-4					M30-4 L	M40-4 L	M50-4 L	M60-4 L				
ITEM	PART NO.	DESCRIPTION	M30-2	M40-2	M50-2	M60-2					M30-2 L	M40-2 L	M50-2 L	M60-2 L				
3	ELECTRICAL ASSEMBLY (FUSES), 4-SPEED																	
108	224774	Switch holder	6	6	6	6					6	6	6	6				
109	224773	Switch holder misc.	3	3	3	3					3	3	3	3				
113	207007	Fuse, 5 A	1	1	1	1					1	1	1	1				
114	173491	Fuse, 7.5 A	1	1	1	1					1	1	1	1				
115	177739	Fuse, 10 A	2	2	2	2					2	2	2	2				
118	473079	Fuse, 20 A	1	1	1	1					1	1	1	1				
119	K33797	Nut	1	1	1	1					1	1	1	1				
124	802784	Jumper	1	1	1	1					1	1	1	1				
125	K33897	Wing nut	2	2	2	2					2	2	2	2				
130	196905	Plug	A/R	A/R	A/R	A/R					A/R	A/R	A/R	A/R				
131	803038	Alarm, backup	1	1	1	1					1	1	1	1				
132	K20344SS	Bolt	2	2	2	2					2	2	2	2				
133	220435	Wiring harness	1	1	1	1					1	1	1	1				

11 AA 11

ELECTRICAL ASSEMBLY (BREAKERS), 4-SPEED

804282)REL

POULTRY TRUCKS - S/N: 750456 & ABOVE
COMMERCIAL TRUCKS - NONE

M30-2	M30-4
M40-2	M40-4
M50-2	M50-4
M60-2	M60-4

M30-2 L	M30-4 L
M40-2 L	M40-4 L
M50-2 L	M50-4 L
M60-2 L	M60-4 L

"CONNECTORS - AS SEEN FROM THE BACK"

- NOTE:
- DO NOT PAINT NEGATIVE GROUND BOLT
 - PROTECT BATTERY TERMINALS WITH ANTI-RUST
 - WIRES MUST NOT TOUCH SHARP EDGES AND CORNERS AND DR SHEET METAL

LEGEND:

VI	-	VIOLET
BC	-	WHITE
RD	-	PINK
R	-	RED
N	-	BLACK
J	-	YELLOW
V	-	GREEN
M	-	BROWN
BL	-	BLUE
DR	-	ORANGE
G	-	GRAY

CIRCUIT BREAKER IDENTIFICATION	WIRE COLOR 'A'	WIRE COLOR 'B'
01 - ROAD LIGHT OPTION LEVER (15A)	YELLOW	YELLOW
02 - WARNING (10A)	YELLOW	YELLOW
03 - REAR WIPER (10A)	RED	RED
04 - REAR WIPER CAB WORK LIGHTS (10A)	RED	RED
05 - WORK LIGHTS (10A)	RED	RED
06 - HEATER OPTION (15A)	RED	RED
07 - DASH PANEL (5A)	RED,RED,RED/BLACK	RED
08 - FRONT WIPER (10A)	PINK	RED
09 - FLASHER UNIT (10A)	RED	RED
10 - SHUTTLE LEVER (10A)	RED,ORANGE,RED/BLACK	RED
11 - HORN / BRAKE LIGHTS (10A)	GREEN,RED	RED
12 - BEACON OPTION(10A)	RED	RED
13 - TAIL LIGHT RIGHT OPTION (5A)	BLUE/WHITE,BLUE/WHITE	BLUE,BLUE
14 - TAIL LIGHT LEFT OPTION(5A)	BLUE,BLUE	BLUE,BLUE
15 - RIGHT TURN SIGNAL OPTION(10A)	GRAY,GRAY	GRAY,GRAY
16 - LEFT TURN SIGNAL OPTION (10A)	BLACK,BLACK	BLACK,BLACK
17 - LOW BEAM OPTION (10A)	YELLOW,YELLOW	YELLOW,YELLOW
18 - HIGH BEAM OPTION (10A)	WHITE,WHITE,WHITE	WHITE
19 - BONE LIGHT OPTION (5A)	YELLOW	YELLOW
20 - FRAME LEVEL (5A)	YELLOW	YELLOW
21 - GAUGES / ENGINE SHUTDOWN (10A)	RED	RED
22 - AXLE COOLER (10A)	BROWN	RED
23 - AXLE COOLER (10A)	ORANGE	RED
24 - 2WD / 4WD SELECTOR (10A)	RED	RED
25 - ENGINE PREHEAT(20A)	BLACK	BLACK

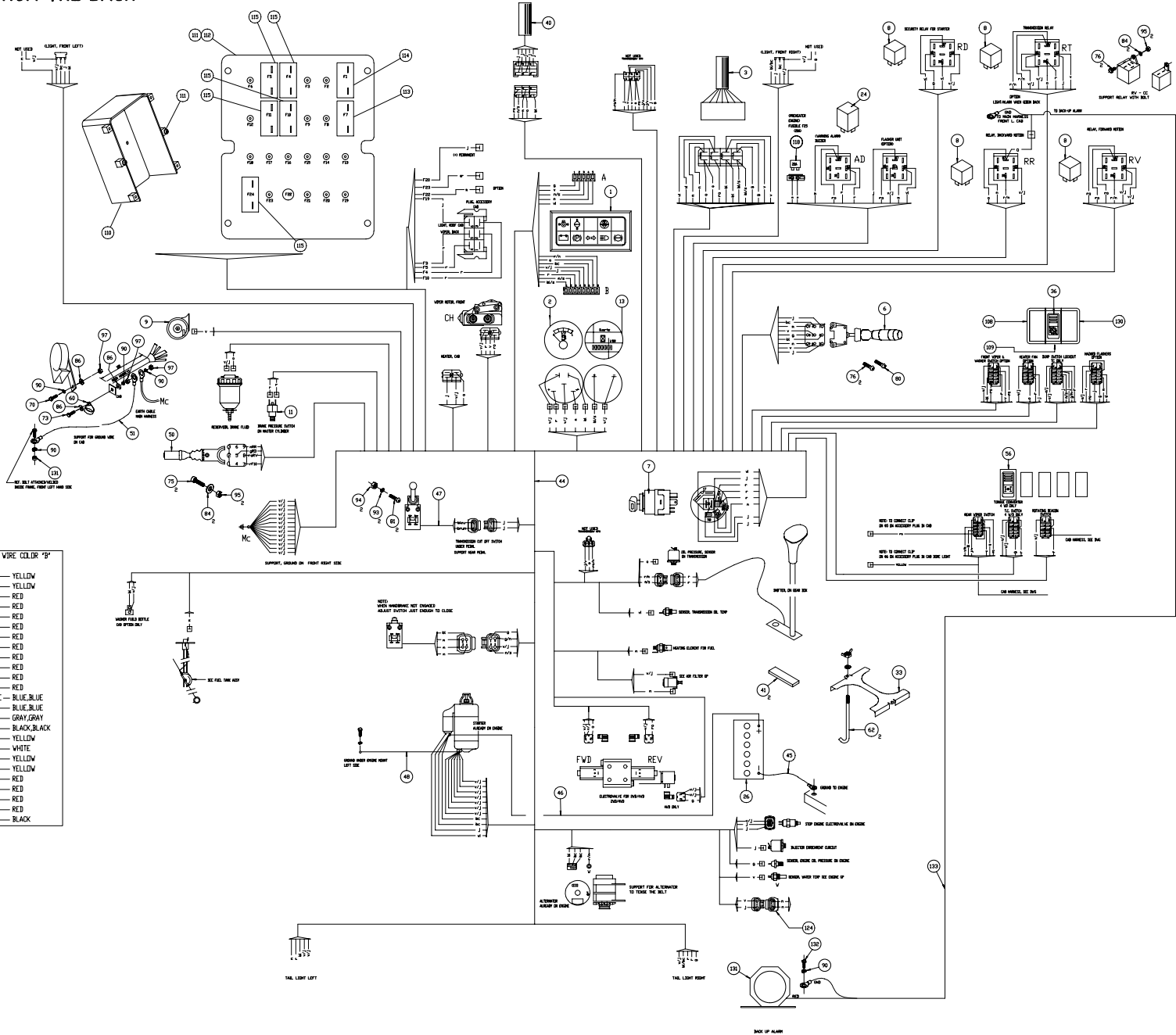

1	ELECTRICAL ASSEMBLY (BREAKERS), 4-SPEED		QUANTITY / MODEL										11 AA 11					
			M30-4	M40-4	M50-4	M60-4					M30-4 L	M40-4 L	M50-4 L	M60-4 L				
ITEM	PART NO.	DESCRIPTION	M30-2	M40-2	M50-2	M60-2					M30-2 L	M40-2 L	M50-2 L	M60-2 L				
1	686343	Panel, warning lights	1	1	1	1					1	1	1	1				
2	686227	Panel, hour meter and fuel gauge	1	1	1	1					1	1	1	1				
3	210942	Test module	1	1	1	1					1	1	1	1				
6	191384	Lever, lighting, horn	1	1	1	1					1	1	1	1				
7	184817	Ignition switch	1	1	1	1					1	1	1	1				
8	231243	Relay	4	4	4	4					4	4	4	4				
9	20125	Horn	1	1	1	1					1	1	1	1				
11	79126	Stop switch, brake lights	1	1	1	1					1	1	1	1				
13	686226	Hourmeter	1	1	1	1					1	1	1	1				
24	176737	Buzzer	1	1	1	1					1	1	1	1				
26	- - - -	Battery, purchase locally	1	1	1	1					1	1	1	1				
33	202703	Strap, battery	1	1	1	1					1	1	1	1				
36	224763	Inching enable switch	1	1	1	1					1	1	1	1				
40	223246	Relay, delay	1	1	1	1					1	1	1	1				
41	41077	Strip, rubber	2	2	2	2					2	2	2	2				
44	803422	Wire harness, main	1	1	1	1					1	1	1	1				
45	425023	Cable, negative battery	1	1	1	1					1	1	1	1				
46	802937	Cable, positive battery	1	1	1	1					1	1	1	1				
47	219100	Transmission cut-off switch	1	1	1	1					1	1	1	1				
48	802977	Cable, negative ground	1	1	1	1					1	1	1	1				
50	234956	Shifter, F-N-R	1	1	1	1					1	1	1	1				
51	215875	Earth cable	1	1	1	1					1	1	1	1				

2	ELECTRICAL ASSEMBLY (BREAKERS), 4-SPEED		QUANTITY / MODEL								11 AA 11							
			M30-4	M40-4	M50-4	M60-4					M30-4 L	M40-4 L	M50-4 L	M60-4 L				
ITEM	PART NO.	DESCRIPTION	M30-2	M40-2	M50-2	M60-2					M30-2 L	M40-2 L	M50-2 L	M60-2 L				
56	238065	2WD / 4WD switch (4WD Models ONLY)	1	1	1	1					1	1	1	1				
60	86506	Clamp	1	1	1	1					1	1	1	1				
62	496687	J Hook, wing nut and washer	2	2	2	2					2	2	2	2				
70	54951	Screw	1	1	1	1					1	1	1	1				
71	42347	Screw	1	1	1	1					1	1	1	1				
73	168348	Screw	1	1	1	1					1	1	1	1				
75	5323	Screw	2	2	2	2					2	2	2	2				
76	79533	Screw	10	10	10	10					10	10	10	10				
80	192041	Screw	1	1	1	1					1	1	1	1				
81	802986	Screw	2	2	2	2					2	2	2	2				
84	28959	Washer	8	8	8	8					8	8	8	8				
86	61674	Washer	2	2	2	2					2	2	2	2				
90	42325	Washer	7	7	7	7					7	7	7	7				
93	78806	Washer	2	2	2	2					2	2	2	2				
94		Nut	2	2	2	2					2	2	2	2				
95	54232	Nut	9	9	9	9					9	9	9	9				
96	K33799SS	Nut	4	4	4	4					4	4	4	4				
97	58528	Nut	4	4	4	4					4	4	4	4				
99	162229	Nut	6	6	6	6					6	6	6	6				

			QUANTITY / MODEL								11 AA 11							
			M30-4	M40-4	M50-4	M60-4					M30-4 L	M40-4 L	M50-4 L	M60-4 L				
3	ELECTRICAL ASSEMBLY (BREAKERS), 4-SPEED		M30-2	M40-2	M50-2	M60-2					M30-2 L	M40-2 L	M50-2 L	M60-2 L				
ITEM	PART NO.	DESCRIPTION	M30-2	M40-2	M50-2	M60-2					M30-2 L	M40-2 L	M50-2 L	M60-2 L				
108	224774	Switch holder	6	6	6	6					6	6	6	6				
109	224773	Switch holder misc.	3	3	3	3					3	3	3	3				
110	804290	Cover assembly	1	1	1	1					1	1	1	1				
111	196951	Screw	7	7	7	7					7	7	7	7				
112	804283	Plate, cover	1	1	1	1					1	1	1	1				
113	804285	Breaker, 5 A	1	1	1	1					1	1	1	1				
114	804288	Breaker, 15 A	1	1	1	1					1	1	1	1				
115	804287	Breaker, 10 A	A/R	A/R	A/R	A/R					A/R	A/R	A/R	A/R				
118	473079	Fuse, 20 A	1	1	1	1					1	1	1	1				
119	K33797	Nut	1	1	1	1					1	1	1	1				
124	802784	Jumper	1	1	1	1					1	1	1	1				
125	K33897	Wing nut	2	2	2	2					2	2	2	2				
130	196905	Plug	A/R	A/R	A/R	A/R					A/R	A/R	A/R	A/R				
131	803038	Alarm, backup	1	1	1	1					1	1	1	1				
132	K20344SS	Bolt	2	2	2	2					2	2	2	2				
133	220435	Wiring harness	1	1	1	1					1	1	1	1				
134	804312	Button boot	A/R	A/R	A/R	A/R					A/R	A/R	A/R	A/R				

11 AA 20

ELECTRICAL ASSEMBLY (FUSES), HYDROSTATIC

802515)Q

POULTRY TRUCKS - S/N: 750453 & BELOW COMMERCIAL TRUCKS - ALL

M30-2 H	M30-4 H
M40-2 H	M40-4 H
M50-2 H	M50-4 H
M60-2 H	M60-4 H
M30-2 H L	M30-4 H L
M40-2 H L	M40-4 H L
M50-2 H L	M50-4 H L
M60-2 H L	M60-4 H L

CONNECTORS - AS SEEN FROM THE BACK

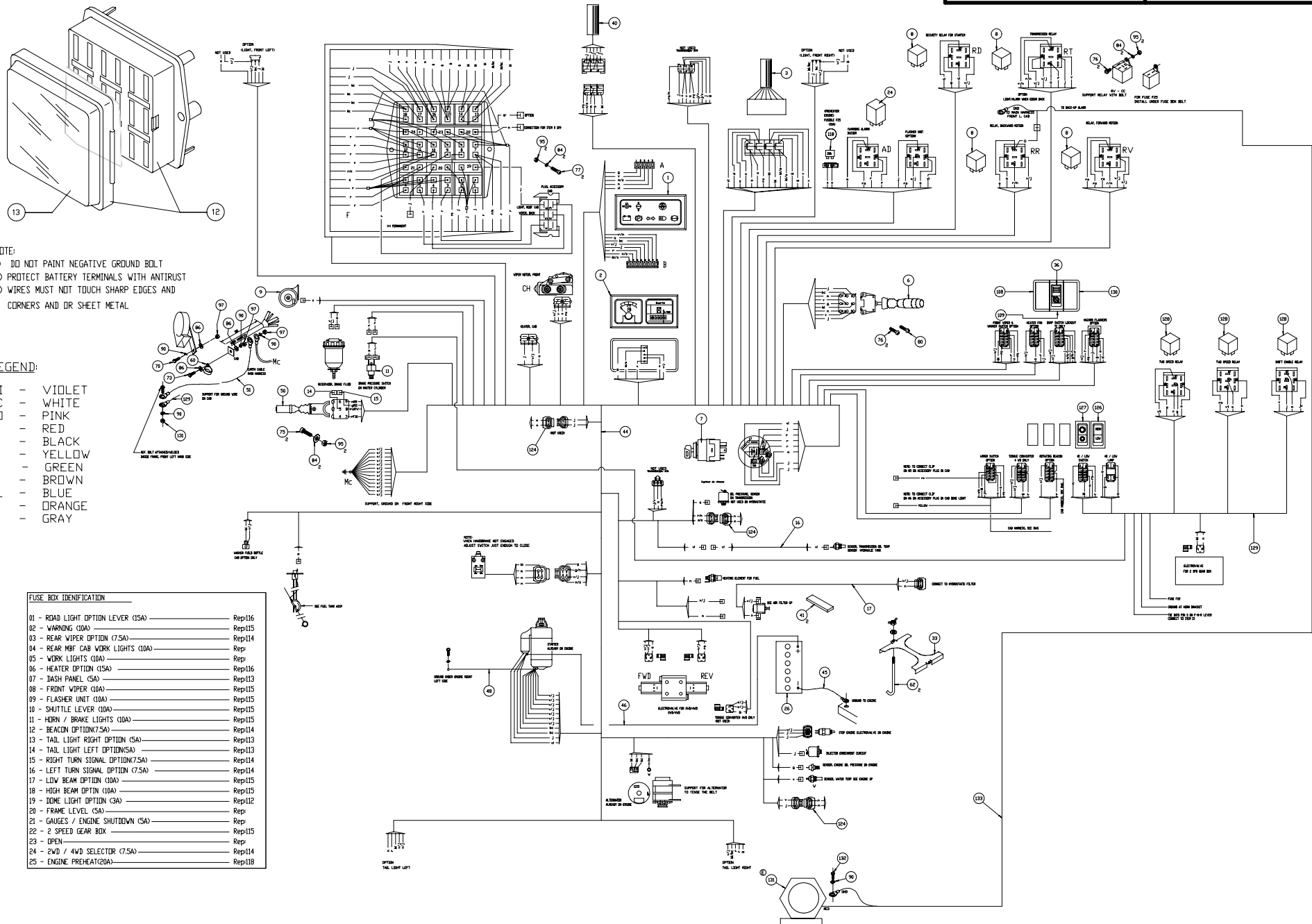

- NOTE:
- 1) DO NOT PAINT NEGATIVE GROUND BOLT
 - 2) PROTECT BATTERY TERMINALS WITH ANTIRUST
 - 3) WIRES MUST NOT TOUCH SHARP EDGES AND CORNERS AND OR SHEET METAL

- LEGEND:
- VI - VIOLET
 - BC - WHITE
 - RD - PINK
 - R - RED
 - N - BLACK
 - J - YELLOW
 - V - GREEN
 - M - BROWN
 - BL - BLUE
 - D - ORANGE
 - G - GRAY

FUSE BOX IDENTIFICATION		
01 - ROAD LIGHT OPTION LEVER (15A)	Rep116	
02 - WARNING (10A)	Rep115	
03 - REAR WIPER OPTION (7.5A)	Rep114	
04 - REAR MSF CAB WORK LIGHTS (10A)	Rep	
05 - WORK LIGHTS (10A)	Rep116	
06 - HEATER OPTION (15A)	Rep113	
07 - DASH PANEL (5A)	Rep115	
08 - FRONT WIPER (10A)	Rep115	
09 - FLASHER UNIT (10A)	Rep115	
10 - SHUTTLE LEVER (10A)	Rep115	
11 - HORN / BRAKE LIGHTS (10A)	Rep115	
12 - BEACON OPTION(7.5A)	Rep114	
13 - TAIL LIGHT RIGHT (OPTION) (5A)	Rep113	
14 - TAIL LIGHT LEFT (OPTION)(5A)	Rep113	
15 - RIGHT TURN SIGNAL (OPTION)(7.5A)	Rep114	
16 - LEFT TURN SIGNAL (OPTION) (7.5A)	Rep115	
17 - LOW BEAM OPTION (10A)	Rep115	
18 - HIGH BEAM OPTION (10A)	Rep115	
19 - DOME LIGHT OPTION (3A)	Rep112	
20 - FRAME LEVEL (5A)	Rep	
21 - GAUGES / ENGINE SHUTDOWN (5A)	Rep	
22 - 2 SPEED GEAR BOX	Rep115	
23 - OPEN	Rep	
24 - 2WD / 4WD SELECTOR (7.5A)	Rep114	
25 - ENGINE PREHEAT(20A)	Rep118	

1	ELECTRICAL ASSEMBLY (FUSES), HYDROSTATIC		QUANTITY / MODEL								11 AA 20							
							M30-4 H	M40-4 H	M50-4 H	M60-4 H					M30-4 H L	M40-4 H L	M50-4 H L	M60-4 H L
ITEM	PART NO.	DESCRIPTION					M30-2 H	M40-2 H	M50-2 H	M60-2 H					M30-2 H L	M40-2 H L	M50-2 H L	M60-2 H L
1A	214516	Panel, warning lights - 1st mounting					1	1	1	1					1	1	1	1
1B	686343	Panel, warning lights - 2nd mounting, replaces 214516					1	1	1	1					1	1	1	1
2	214517	Panel, hour meter and fuel gauge					1	1	1	1					1	1	1	1
3	210942	Test module					1	1	1	1					1	1	1	1
6	191384	Lever, lighting, horn					1	1	1	1					1	1	1	1
7	184817	Ignition switch					1	1	1	1					1	1	1	1
8	231243	Relay					4	4	4	4					4	4	4	4
9	20125	Horn					1	1	1	1					1	1	1	1
11	79126	Stop switch, brake lights					1	1	1	1					1	1	1	1
12	562044	Fuse panel					1	1	1	1					1	1	1	1
13	561322	Fuse box cover					1	1	1	1					1	1	1	1
16	802935	Wire assembly					1	1	1	1					1	1	1	1
17	802936	Harness assembly					1	1	1	1					1	1	1	1
24	176737	Buzzer					1	1	1	1					1	1	1	1
26	- - - -	Purchase locally					1	1	1	1					1	1	1	1
33	202703	Strap, battery					1	1	1	1					1	1	1	1
41	41077	Strip, rubber					2	2	2	2					2	2	2	2
44	246700	Wire harness, main					1	1	1	1					1	1	1	1
45	84307	Cable, negative battery					1	1	1	1					1	1	1	1
46	802937	Cable, positive battery					1	1	1	1					1	1	1	1
48	802977	Cable, negative ground					1	1	1	1					1	1	1	1

2	ELECTRICAL ASSEMBLY (FUSES), HYDROSTATIC		QUANTITY / MODEL								11 AA 20							
							M30-4 H	M40-4 H	M50-4 H	M60-4 H					M30-4 H L	M40-4 H L	M50-4 H L	M60-4 H L
ITEM	PART NO.	DESCRIPTION					M30-2 H	M40-2 H	M50-2 H	M60-2 H					M30-2 H L	M40-2 H L	M50-2 H L	M60-2 H L
50	234956	Shifter, F-N-R					1	1	1	1					1	1	1	1
51	215875	Earth cable					1	1	1	1					1	1	1	1
60	86506	Clamp					1	1	1	1					1	1	1	1
61	221391	Horn bracket					1	1	1	1					1	1	1	1
62	496687	J Hook, wing nut and washer					2	2	2	2					2	2	2	2
70	54951	Screw					1	1	1	1					1	1	1	1
71	42347	Screw					1	1	1	1					1	1	1	1
73	168348	Screw					1	1	1	1					1	1	1	1
75	5323	Screw					2	2	2	2					2	2	2	2
76	79533	Screw					10	10	10	10					10	10	10	10
77	206082	Screw					2	2	2	2					2	2	2	2
80	192041	Screw					1	1	1	1					1	1	1	1
84	28959	Washer					8	8	8	8					8	8	8	8
86	61674	Washer					2	2	2	2					2	2	2	2
90	42325	Washer					7	7	7	7					7	7	7	7
95	54232	Nut					8	8	8	8					8	8	8	8
96	K33799SS	Nut					4	4	4	4					4	4	4	4
97	58528	Nut					4	4	4	4					4	4	4	4
99	162229	Nut					6	6	6	6					6	6	6	6

3	ELECTRICAL ASSEMBLY (FUSES), HYDROSTATIC		QUANTITY / MODEL								11 AA 20							
							M30-4 H	M40-4 H	M50-4 H	M60-4 H					M30-4 H L	M40-4 H L	M50-4 H L	M60-4 H L
ITEM	PART NO.	DESCRIPTION					M30-2 H	M40-2 H	M50-2 H	M60-2 H					M30-2 H L	M40-2 H L	M50-2 H L	M60-2 H L
108	224774	Switch holder					6	6	6	6					6	6	6	6
109	224773	Switch holder misc.					3	3	3	3					3	3	3	3
110	173354	Clip					2	2	2	2					2	2	2	2
111	B254-2	Rivet					2	2	2	2					2	2	2	2
113	207007	Fuse, 5 A					1	1	1	1					1	1	1	1
114	173491	Fuse, 7.5 A					1	1	1	1					1	1	1	1
115	177739	Fuse, 10 A					3	3	3	3					3	3	3	3
118	473079	Fuse, 20 A					1	1	1	1					1	1	1	1
119	K33797	Nut					1	1	1	1					1	1	1	1
124	802784	Jumper					3	3	3	3					3	3	3	3
125	K33897	Wing nut					2	2	2	2					2	2	2	2
126	231464	High low gear light					1	1	1	1					1	1	1	1
127	233870	High low gear switch					1	1	1	1					1	1	1	1
128	231244	Relay					2	2	2	2					2	2	2	2
129	802516	Wire harness, 2 speed gear box					1	1	1	1					1	1	1	1
130	196905	Plug					7	7	7	7					7	7	7	7
131	803038	Alarm, backup					1	1	1	1					1	1	1	1
132	K20344SS	Bolt					2	2	2	2					2	2	2	2
133	220435	Wiring harness					1	1	1	1					1	1	1	1

11 AA 21

ELECTRICAL ASSEMBLY (BREAKERS), HYDROSTATIC

804294)REL

POULTRY TRUCKS - S/N: 750454 & ABOVE
COMMERCIAL TRUCKS - NONE

M30-2 H	M30-4 H
M40-2 H	M40-4 H
M50-2 H	M50-4 H
M60-2 H	M60-4 H

M30-2 H L	M30-4 H L
M40-2 H L	M40-4 H L
M50-2 H L	M50-4 H L
M60-2 H L	M60-4 H L

CONNECTORS - AS SEEN FROM THE BACK

- NOTE:
1) DO NOT PAINT NEGATIVE GROUND BOLT
2) PROTECT BATTERY TERMINALS WITH ANTRIRUST
3) WIRES MUST NOT TOUCH SHARP EDGES AND CORNERS AND DR SHEET METAL

LEGEND:

- VI - VIOLET
- BC - WHITE
- RD - PINK
- R - RED
- N - BLACK
- J - YELLOW
- V - GREEN
- M - BROWN
- BL - BLUE
- D - ORANGE
- G - GRAY

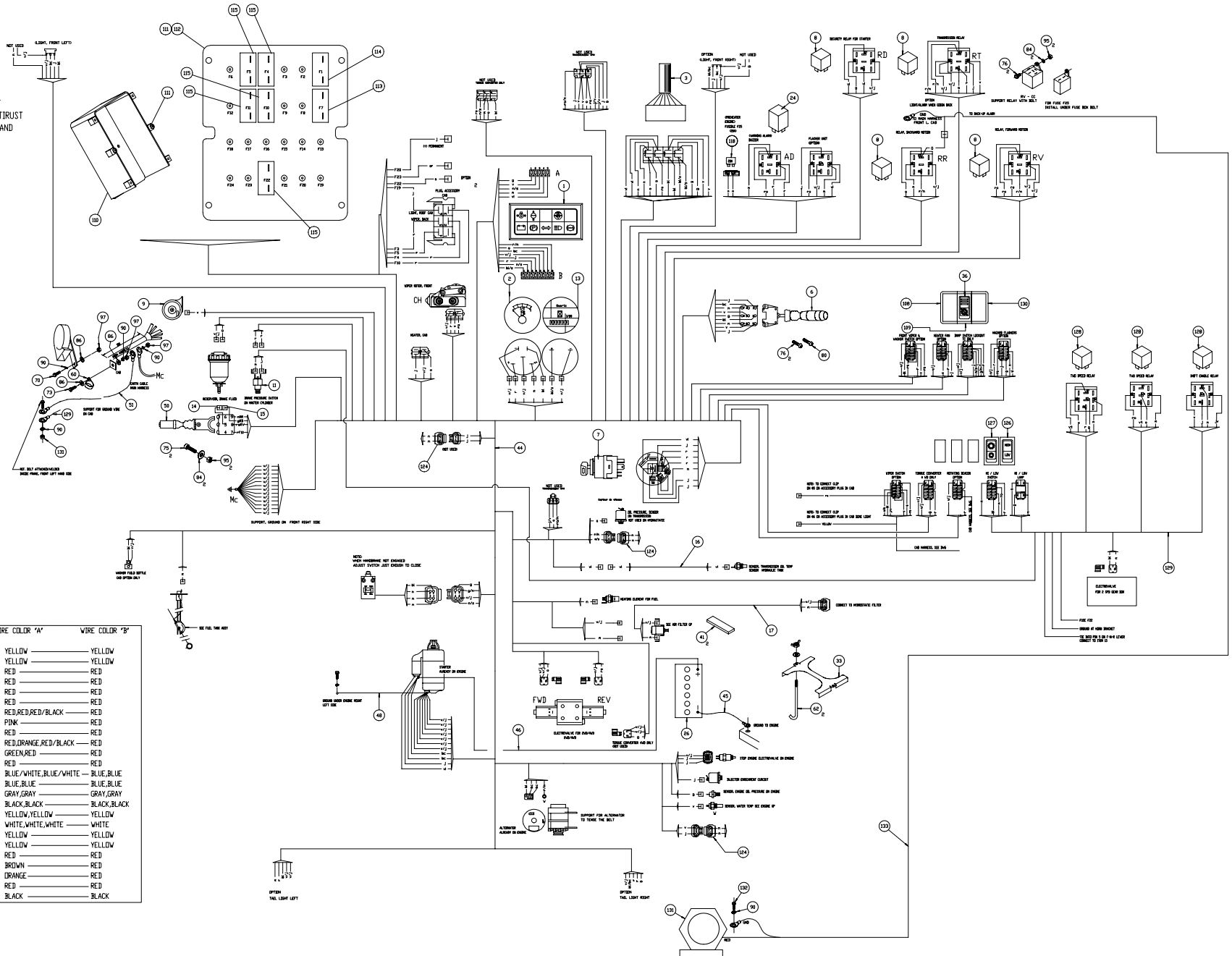

CIRCUIT BREAKER IDENTIFICATION	WIRE COLOR "A"	WIRE COLOR "B"
01 - ROAD LIGHT OPTION LEVER (15A)	YELLOW	YELLOW
02 - WARNING (10A)	YELLOW	YELLOW
03 - REAR WIPER OPTION (10A)	RED	RED
04 - REAR MBF CAB WORK LIGHTS (10A)	RED	RED
05 - WORK LIGHTS (10A)	RED	RED
06 - HEATER OPTION (15A)	RED	RED
07 - DASH PANEL (5A)	RED	RED
08 - FRONT WIPER (10A)	RED,RED,RED/BLACK	RED
09 - FLASHER UNIT (10A)	RED	RED
10 - SHUTTLE LEVER (10A)	RED,ORANGE,RED/BLACK	RED
11 - HORN / BRAKE LIGHTS (10A)	GREEN,RED	RED
12 - BEACON OPTION(10A)	RED	RED
13 - TAIL LIGHT RIGHT OPTION (5A)	BLUE/WHITE,BLUE/WHITE	BLUE,BLUE
14 - TAIL LIGHT LEFT OPTION(5A)	BLUE,BLUE	BLUE,BLUE
15 - RIGHT TURN SIGNAL OPTION(10A)	GRAY,GRAY	GRAY,GRAY
16 - LEFT TURN SIGNAL OPTION (10A)	BLACK,BLACK	BLACK,BLACK
17 - LOW BEAM OPTION (10A)	YELLOW,YELLOW	YELLOW
18 - HIGH BEAM OPTIN (10A)	WHITE,WHITE,WHITE	WHITE
19 - DOME LIGHT OPTION (3A)	YELLOW	YELLOW
20 - FRAME LEVEL (5A)	YELLOW	YELLOW
21 - GAUGES / ENGINE SHUTDOWN (10A)	RED	RED
22 - 2 SPEED GEAR BDX (10A)	BROWN	RED
23 - OPEN	ORANGE	RED
24 - 2WD / 4WD SELECTOR (10A)	RED	RED
25 - ENGINE PREHEAT(20A)	BLACK	BLACK

1	ELECTRICAL ASSEMBLY (BREAKERS), HYDROSTATIC		QUANTITY / MODEL								11 AA 21							
							M30-4 H	M40-4 H	M50-4 H	M60-4 H					M30-4 H L	M40-4 H L	M50-4 H L	M60-4 H L
ITEM	PART NO.	DESCRIPTION					M30-2 H	M40-2 H	M50-2 H	M60-2 H					M30-2 H L	M40-2 H L	M50-2 H L	M60-2 H L
1	686343	Panel, warning lights					1	1	1	1					1	1	1	1
2	686227	Fuel gauge					1	1	1	1					1	1	1	1
3	210942	Test module					1	1	1	1					1	1	1	1
6	191384	Lever, lighting, horn					1	1	1	1					1	1	1	1
7	184817	Ignition switch					1	1	1	1					1	1	1	1
8	231243	Relay					4	4	4	4					4	4	4	4
9	20125	Horn					1	1	1	1					1	1	1	1
11	79126	Stop switch, brake lights					1	1	1	1					1	1	1	1
13	686226	Hourmeter					1	1	1	1					1	1	1	1
16	802935	Wire assembly					1	1	1	1					1	1	1	1
17	802936	Harness assembly					1	1	1	1					1	1	1	1
24	176737	Buzzer					1	1	1	1					1	1	1	1
26	- - - -	Battery, purchase locally					1	1	1	1					1	1	1	1
33	202703	Strap, battery					1	1	1	1					1	1	1	1
41	41077	Strip, rubber					2	2	2	2					2	2	2	2
44	803422	Wire harness, main					1	1	1	1					1	1	1	1
45	84307	Cable, negative battery					1	1	1	1					1	1	1	1
46	802937	Cable, positive battery					1	1	1	1					1	1	1	1
48	802977	Cable, negative ground					1	1	1	1					1	1	1	1

2	ELECTRICAL ASSEMBLY (BREAKERS), HYDROSTATIC		QUANTITY / MODEL								11 AA 21							
							M30-4 H	M40-4 H	M50-4 H	M60-4 H					M30-4 H L	M40-4 H L	M50-4 H L	M60-4 H L
ITEM	PART NO.	DESCRIPTION					M30-2 H	M40-2 H	M50-2 H	M60-2 H					M30-2 H L	M40-2 H L	M50-2 H L	M60-2 H L
50	234956	Shifter, F-N-R					1	1	1	1					1	1	1	1
51	215875	Earth cable					1	1	1	1					1	1	1	1
60	86506	Clamp					1	1	1	1					1	1	1	1
62	496687	J Hook, wing nut and washer					2	2	2	2					2	2	2	2
70	54951	Screw					1	1	1	1					1	1	1	1
73	168348	Screw					1	1	1	1					1	1	1	1
75	5323	Screw					2	2	2	2					2	2	2	2
76	79533	Screw					10	10	10	10					10	10	10	10
80	192041	Screw					1	1	1	1					1	1	1	1
84	28959	Washer					8	8	8	8					8	8	8	8
86	61674	Washer					2	2	2	2					2	2	2	2
90	42325	Washer					7	7	7	7					7	7	7	7
95	54232	Nut					8	8	8	8					8	8	8	8
97	58528	Nut					4	4	4	4					4	4	4	4

3	ELECTRICAL ASSEMBLY (BREAKERS), HYDROSTATIC		QUANTITY / MODEL								11 AA 21							
							M30-4 H	M40-4 H	M50-4 H	M60-4 H					M30-4 H L	M40-4 H L	M50-4 H L	M60-4 H L
ITEM	PART NO.	DESCRIPTION					M30-2 H	M40-2 H	M50-2 H	M60-2 H					M30-2 H L	M40-2 H L	M50-2 H L	M60-2 H L
108	224774	Switch holder					6	6	6	6					6	6	6	6
109	224773	Switch holder misc.					3	3	3	3					3	3	3	3
110	804290	Cover assembly					1	1	1	1					1	1	1	1
111	196951	Screw					7	7	7	7					7	7	7	7
112	804283	Plate, cover					1	1	1	1					1	1	1	1
113	804285	Circuit breaker, 5 A					1	1	1	1					1	1	1	1
114	804288	Circuit breaker, 15 A					1	1	1	1					1	1	1	1
115	804287	Circuit breaker, 10 A					3	3	3	3					3	3	3	3
118	473079	Fuse, 20 A					1	1	1	1					1	1	1	1
119	K33797	Nut					1	1	1	1					1	1	1	1
124	802784	Jumper					3	3	3	3					3	3	3	3
125	K33897	Wing nut					2	2	2	2					2	2	2	2
126	231464	High low gear light					1	1	1	1					1	1	1	1
127	233870	High low gear switch					1	1	1	1					1	1	1	1
128	231244	Relay					2	2	2	2					2	2	2	2
129	802516	Wire harness, 2 speed gear box					1	1	1	1					1	1	1	1
130	196905	Plug					7	7	7	7					7	7	7	7
131	803038	Alarm, backup					1	1	1	1					1	1	1	1
132	K20344SS	Bolt					2	2	2	2					2	2	2	2
133	220435	Wiring harness					1	1	1	1					1	1	1	1
134	804312	Button boot					A/R	A/R	A/R	A/R					A/R	A/R	A/R	A/R

11 AB 10

HEATER, SEMI AND OPEN CAB

M30-2	M30-4	M30-2 H	M30-4 H
M40-2	M40-4	M40-2 H	M40-4 H
M50-2	M50-4	M50-2 H	M50-4 H
M60-2	M60-4	M60-2 H	M60-4 H
M30-2 L	M30-4 L	M30-2 H L	M30-4 H L
M40-2 L	M40-4 L	M40-2 H L	M40-4 H L
M50-2 L	M50-4 L	M50-2 H L	M50-4 H L
M60-2 L	M60-4 L	M60-2 H L	M60-4 H L

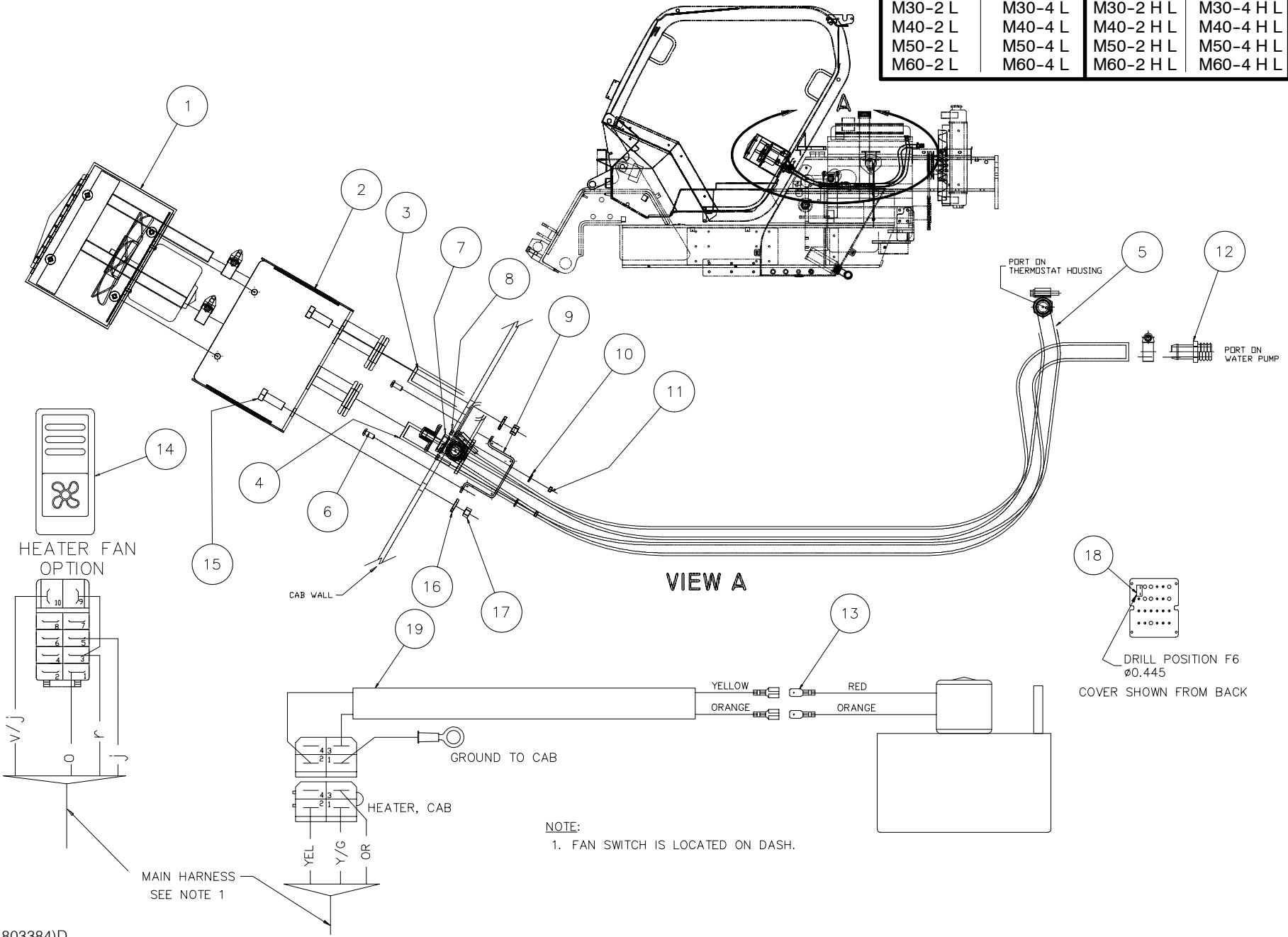

1	HEATER, SEMI AND OPEN CAB		QUANTITY / MODEL												11 AB 10			
			M30-4	M40-4	M50-4	M60-4	M30-4 H	M40-4 H	M50-4 H	M60-4 H	M30-4 L	M40-4 L	M50-4 L	M60-4 L	M30-4 H L	M40-4 H L	M50-4 H L	M60-4 H L
ITEM	PART NO.	DESCRIPTION	M30-2	M40-2	M50-2	M60-2	M30-2 H	M40-2 H	M50-2 H	M60-2 H	M30-2 L	M40-2 L	M50-2 L	M60-2 L	M30-2 H L	M40-2 H L	M50-2 H L	M60-2 H L
1	B3354-7	Heater assembly	1	1	1	1	1	1	1	1	1	1	1	1	1	1	1	1
2	493370	Heater mount	1	1	1	1	1	1	1	1	1	1	1	1	1	1	1	1
3	802822	Heater hose, 30 in.	1	1	1	1	1	1	1	1	1	1	1	1	1	1	1	1
4	802821	Heater hose, 93 in.	1	1	1	1	1	1	1	1	1	1	1	1	1	1	1	1
5	802820	Heater hose 117 in.	1	1	1	1	1	1	1	1	1	1	1	1	1	1	1	1
6	79533	Screw	2	2	2	2	2	2	2	2	2	2	2	2	2	2	2	2
7	198060	Heater control valve	1	1	1	1	1	1	1	1	1	1	1	1	1	1	1	1
8	4240	Bolt	2	2	2	2	2	2	2	2	2	2	2	2	2	2	2	2
9	196821	Bracket	1	1	1	1	1	1	1	1	1	1	1	1	1	1	1	1
10	28959	Washer	2	2	2	2	2	2	2	2	2	2	2	2	2	2	2	2
11	54232	Nut	2	2	2	2	2	2	2	2	2	2	2	2	2	2	2	2
12	198059	Connector	2	2	2	2	2	2	2	2	2	2	2	2	2	2	2	2
13	B3183	Push-on connector	2	2	2	2	2	2	2	2	2	2	2	2	2	2	2	2
14	231486	Dash switch	1	1	1	1	1	1	1	1	1	1	1	1	1	1	1	1
15	K20388SS	Bolt	3	3	3	3	3	3	3	3	3	3	3	3	3	3	3	3
16	K34807SS	Washer, lock	3	3	3	3	3	3	3	3	3	3	3	3	3	3	3	3
17	K33799SS	Nut	3	3	3	3	3	3	3	3	3	3	3	3	3	3	3	3
18	804288	Circuit breaker, 15 A	1	1	1	1	1	1	1	1	1	1	1	1	1	1	1	1
19	804662	Harness, cab heater	1	1	1	1	1	1	1	1	1	1	1	1	1	1	1	1

11 BA 10

ELECTRICAL, OVERHEAD WORK LIGHTS

M30-2	M30-4	M30-2 H	M30-4 H
M40-2	M40-4	M40-2 H	M40-4 H
M50-2	M50-4	M50-2 H	M50-4 H
M60-2	M60-4	M60-2 H	M60-4 H
M30-2 L	M30-4 L	M30-2 H L	M30-4 H L
M40-2 L	M40-4 L	M40-2 H L	M40-4 H L
M50-2 L	M50-4 L	M50-2 H L	M50-4 H L
M60-2 L	M60-4 L	M60-2 H L	M60-4 H L

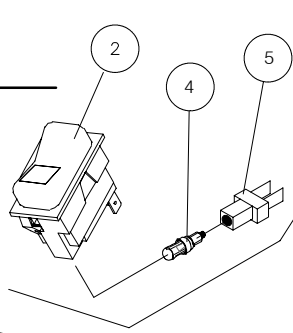

ALL MODELS

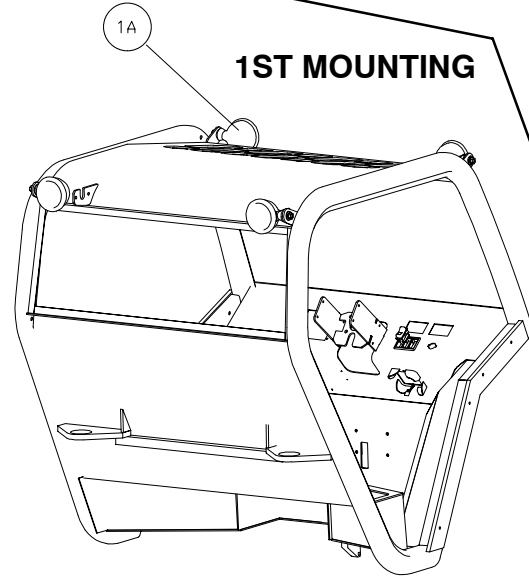

1ST MOUNTING

2ND MOUNTING

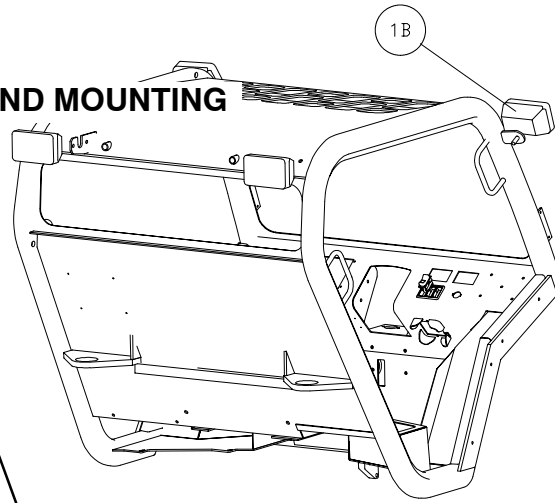

3RD MOUNTING

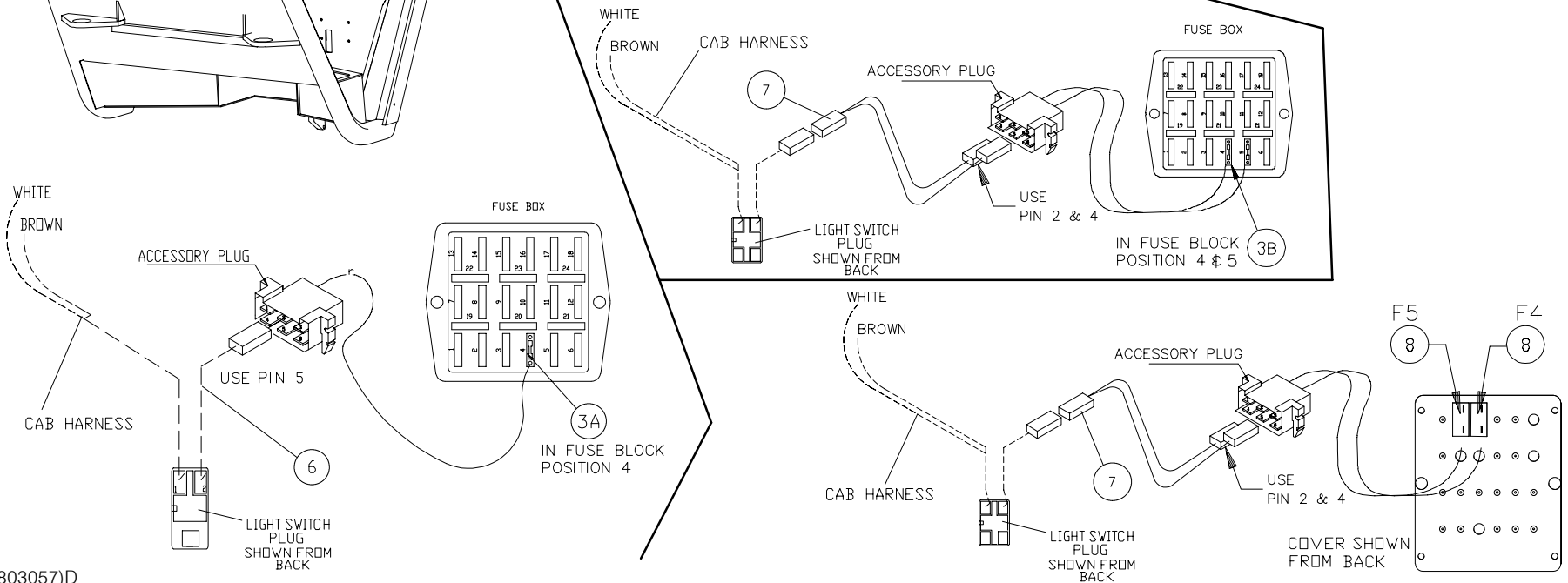
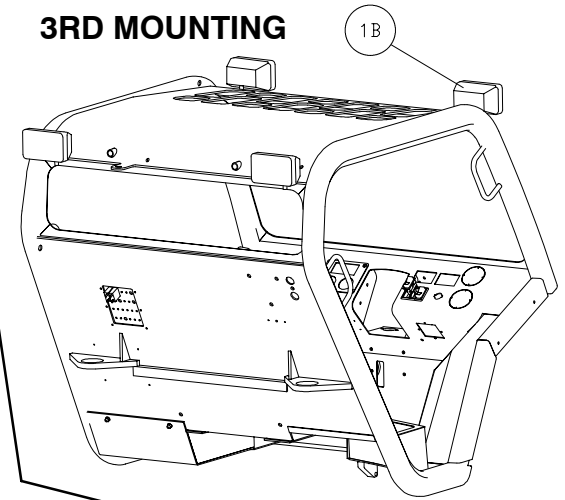

1	ELECTRICAL, OVERHEAD WORK LIGHTS		QUANTITY / MODEL											11 BA 10				
			M30-4	M40-4	M50-4	M60-4	M30-4 H	M40-4 H	M50-4 H	M60-4 H	M30-4 L	M40-4 L	M50-4 L	M60-4 L	M30-4 H L	M40-4 H L	M50-4 H L	M60-4 H L
ITEM	PART NO.	DESCRIPTION	M30-2	M40-2	M50-2	M60-2	M30-2 H	M40-2 H	M50-2 H	M60-2 H	M30-2 L	M40-2 L	M50-2 L	M60-2 L	M30-2 H L	M40-2 H L	M50-2 H L	M60-2 H L
1A	B3344	Round Light, white work	4	4	4	4	4	4	4	4	4	4	4	4	4	4	4	4
1B	223480	Rectangle Light, white work	4	4	4	4	4	4	4	4	4	4	4	4	4	4	4	4
2	487961	Switch, work lights (less bulb and bulb holder)	A/R	A/R	A/R	A/R	A/R	A/R	A/R	A/R	A/R	A/R	A/R	A/R	A/R	A/R	A/R	A/R
3A	473079	Fuse, 20 amp	1	1	1	1	1	1	1	1	1	1	1	1	1	1	1	1
3B	177739	Fuse, 10 amp	2	2	2	2	2	2	2	2	2	2	2	2	2	2	2	2
4	170836	Light bulb	1	1	1	1	1	1	1	1	1	1	1	1	1	1	1	1
5	554629	Bulb holder	1	1	1	1	1	1	1	1	1	1	1	1	1	1	1	1
6	220222	Harness	1	1	1	1	1	1	1	1	1	1	1	1	1	1	1	1
7	804177	Harness	1	1	1	1	1	1	1	1	1	1	1	1	1	1	1	1
8	804287	Circuit breaker, 10 A	2	2	2	2	2	2	2	2	2	2	2	2	2	2	2	2

11 BA 20

ELECTRICAL, ROAD LIGHTING OPTION

M30-2	M30-4	M30-2 H	M30-4 H
M40-2	M40-4	M40-2 H	M40-4 H
M50-2	M50-4	M50-2 H	M50-4 H
M60-2	M60-4	M60-2 H	M60-4 H

M30-2 L	M30-4 L	M30-2 H L	M30-4 H L
M40-2 L	M40-4 L	M40-2 H L	M40-4 H L
M50-2 L	M50-4 L	M50-2 H L	M50-4 H L
M60-2 L	M60-4 L	M60-2 H L	M60-4 H L

1ST MOUNTING (FUSES)

FUSE BOX IDENTIFICATION

- 01 - ROAD LIGHT OPTION (15A) _____ Rep:15
- 02 - WARNING (10A) _____
- 03 - REAR WIPER OPTION (7.5A) _____
- 04 - REAR WORKING LIGHTS(15A) _____
- 05 - OPEN _____
- 06 - HEATER OPTION (15A) _____
- 07 - DASH PANEL (5A) _____
- 08 - FRONT WIPER (10A) _____
- 09 - FLASHER UNIT (10A) _____ Rep:16
- 10 - SHUTTLE LEVER (10A) _____
- 11 - KLAXON AV + FEUX DE STOP (10A) _____
- 12 - BEACON OPTION(7.5A) _____
- 13 - TAIL LIGHT RIGHT OPTION (5A) _____ Rep:18
- 14 - TAIL LIGHT LEFT OPTION(5A) _____ Rep:18
- 15 - RIGHT TURN SIGNAL OPTION(7.5A) _____ Rep:17
- 16 - LEFT TURN SIGNAL OPTION (7.5A) _____ Rep:17
- 17 - LDW BEAM OPTION (10A) _____ Rep:16
- 18 - HIGH BEAM OPTIN (10A) _____ Rep:16
- 19 - DOME LIGHT OPTION (3A) _____
- 20 - OPEN _____
- 21 - OPEN _____
- 22 - 2 SPEED GEAR BDX _____
- 23 - OPEN _____
- 24 - 2WD / 4WD SELECTOR (7.5A) _____
- 25 - ENGINE PREHEAT(20A) _____

15 16 17 18 FUSES

2ND MOUNTING (BREAKERS)

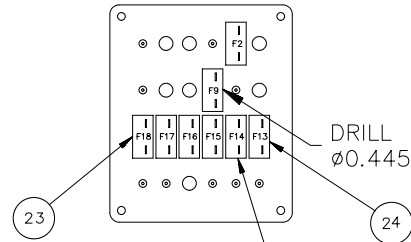

COVER SHOWN FROM BACK

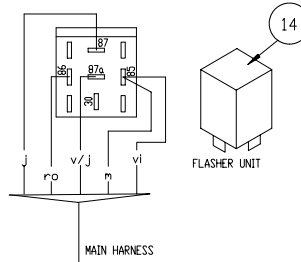

Wiring Color Code
Left Rear Lights

- Green/Yellow > Ground
- Blue > Back-Up Light
- Red > Brake Light
- Black > Turn-Signal Light

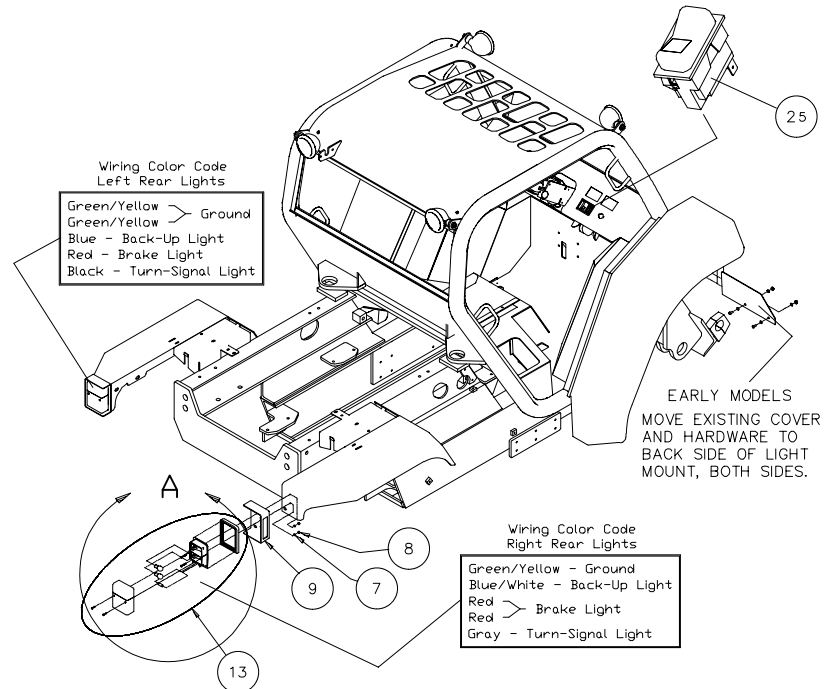

Wiring Color Code
Right Rear Lights

- Green/Yellow - Ground
- Blue/White - Back-Up Light
- Red > Brake Light
- Gray - Turn-Signal Light

1ST MOUNTING HEADLIGHTS

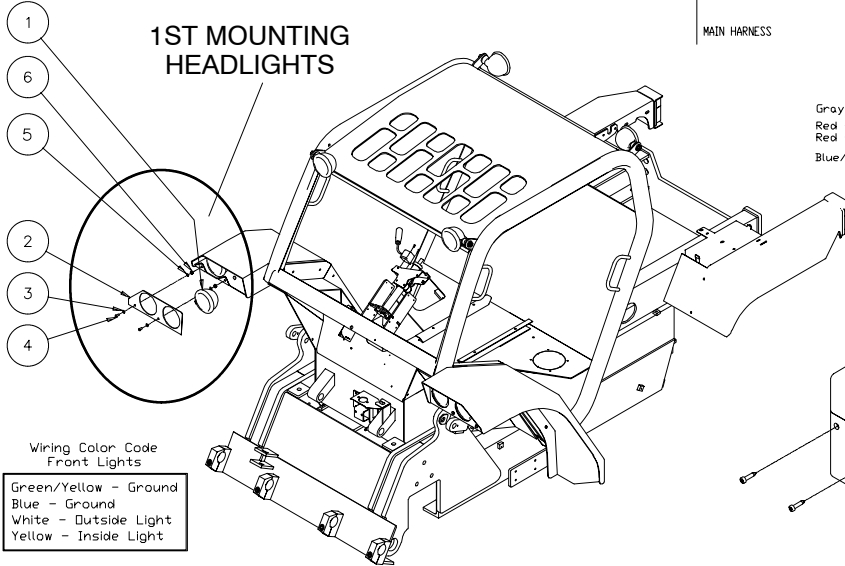

Wiring Color Code Front Lights

- Green/Yellow - Ground
- Blue - Ground
- White - Outside Light
- Yellow - Inside Light

- Gray - Right Turn-Signal
- Red > Right Brake Light
- Blue/White - Right Back-Up Light

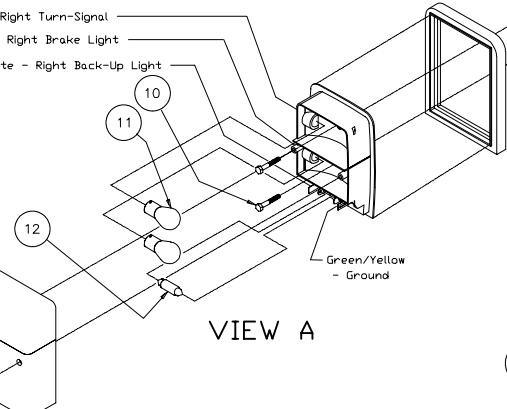

2ND MOUNTING HEADLIGHTS

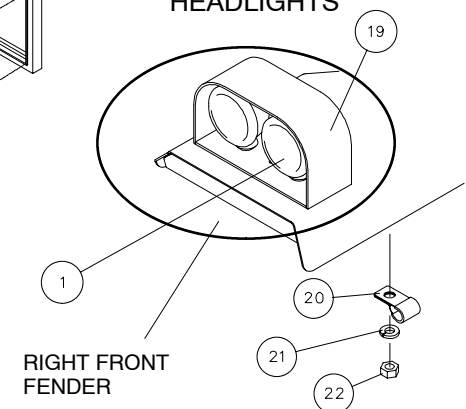

RIGHT FRONT FENDER

1	ELECTRICAL, ROAD LIGHTING OPTION												11 BA 20						
	ITEM	PART NO.	DESCRIPTION	M30-2	M40-2	M50-2	M60-2	M30-2 H	M40-2 H	M50-2 H	M60-2 H	M30-2 L	M40-2 L	M50-2 L	M60-2 L	M30-2 H L	M40-2 H L	M50-2 H L	M60-2 H L
1	B3344	Light, white	4	4	4	4	4	4	4	4	4	4	4	4	4	4	4	4	4
2	802649	Face plate	2	2	2	2	2	2	2	2	2	2	2	2	2	2	2	2	2
3	61674	Washer, flat	4	4	4	4	4	4	4	4	4	4	4	4	4	4	4	4	4
4	202731	Screw	4	4	4	4	4	4	4	4	4	4	4	4	4	4	4	4	4
5	42325	Washer, lock	4	4	4	4	4	4	4	4	4	4	4	4	4	4	4	4	4
6	58528	Nut	4	4	4	4	4	4	4	4	4	4	4	4	4	4	4	4	4
7	192310	Washer, lock	4	4	4	4	4	4	4	4	4	4	4	4	4	4	4	4	4
8	54232	Nut	4	4	4	4	4	4	4	4	4	4	4	4	4	4	4	4	4
9	219533	Tail lijt bracket	2	2	2	2	2	2	2	2	2	2	2	2	2	2	2	2	2
10	58523	Bolt	4	4	4	4	4	4	4	4	4	4	4	4	4	4	4	4	4
11	675	Bulb, 21W	4	4	4	4	4	4	4	4	4	4	4	4	4	4	4	4	4
12	676	Bulb, 5W	2	2	2	2	2	2	2	2	2	2	2	2	2	2	2	2	2
13	2163	Tail light assembly	2	2	2	2	2	2	2	2	2	2	2	2	2	2	2	2	2
14	169917	Flasher unit	1	1	1	1	1	1	1	1	1	1	1	1	1	1	1	1	1
15	205805	Fuse, 15 amp - 1ST MOUNTING	A/R	A/R	A/R	A/R	A/R	A/R	A/R	A/R	A/R	A/R	A/R	A/R	A/R	A/R	A/R	A/R	A/R
16	177739	Fuse, 10 amp - 1ST MOUNTING	A/R	A/R	A/R	A/R	A/R	A/R	A/R	A/R	A/R	A/R	A/R	A/R	A/R	A/R	A/R	A/R	A/R
17	173491	Fuse, 7.5 amp - 1ST MOUNTING	A/R	A/R	A/R	A/R	A/R	A/R	A/R	A/R	A/R	A/R	A/R	A/R	A/R	A/R	A/R	A/R	A/R
18	207007	Fuse, 5 amp - 1ST MOUNTING	A/R	A/R	A/R	A/R	A/R	A/R	A/R	A/R	A/R	A/R	A/R	A/R	A/R	A/R	A/R	A/R	A/R
19	496680	Guard, headlight (without lights)	2	2	2	2	2	2	2	2	2	2	2	2	2	2	2	2	2
20	B3698-2	Clamp	6	6	6	6	6	6	6	6	6	6	6	6	6	6	6	6	6
21	42316	Washer, lock	6	6	6	6	6	6	6	6	6	6	6	6	6	6	6	6	6
22	25714	Nut	6	6	6	6	6	6	6	6	6	6	6	6	6	6	6	6	6
23	804287	Circuit breaker, 10 amp - 2ND MOUNTING	6	6	6	6	6	6	6	6	6	6	6	6	6	6	6	6	6
24	804285	Circuit breaker, 5 amp - 2ND MOUNTING	2	2	2	2	2	2	2	2	2	2	2	2	2	2	2	2	2
25	224767	Flasher switch	1	1	1	1	1	1	1	1	1	1	1	1	1	1	1	1	1

11 BA 30

ELECTRICAL, POULTRY/BACK DOCK LIGHTING OPTION

M30-2	M30-4	M30-2 H	M30-4 H
M40-2	M40-4	M40-2 H	M40-4 H
M50-2	M50-4	M50-2 H	M50-4 H
M60-2	M60-4	M60-2 H	M60-4 H
M30-2 L	M30-4 L	M30-2 H L	M30-4 H L
M40-2 L	M40-4 L	M40-2 H L	M40-4 H L
M50-2 L	M50-4 L	M50-2 H L	M50-4 H L
M60-2 L	M60-4 L	M60-2 H L	M60-4 H L

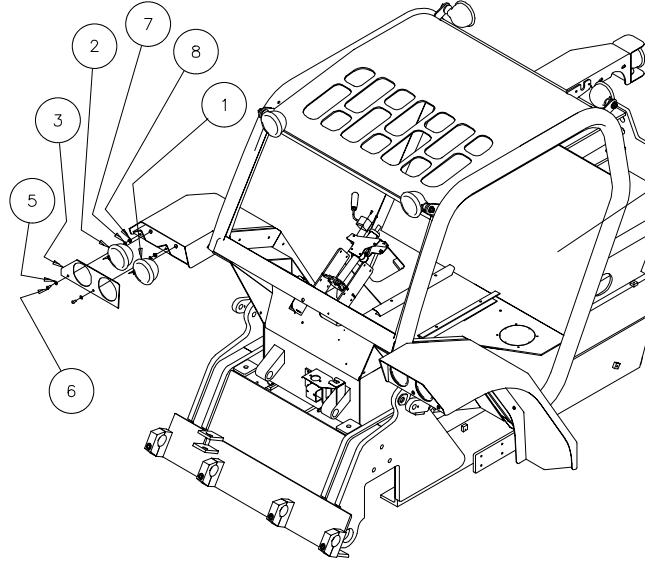

1ST MOUNTING

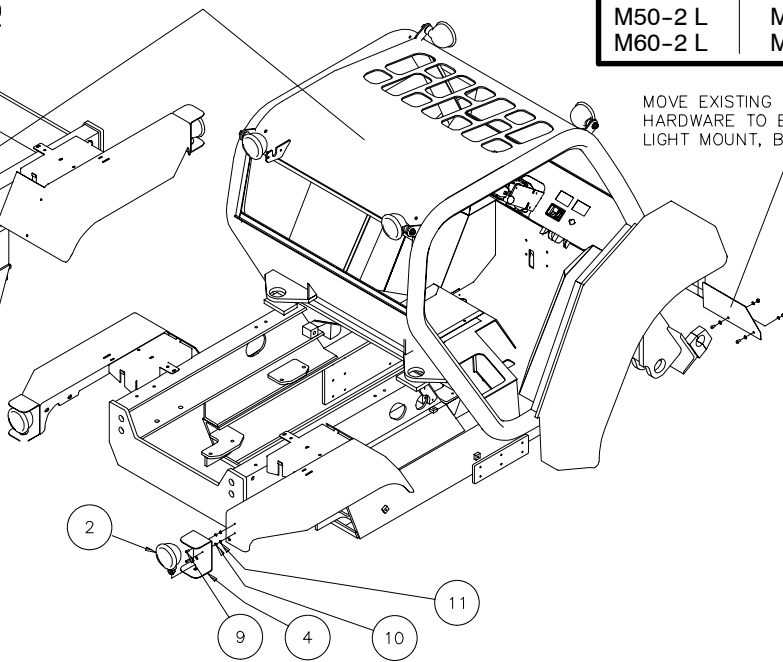

MOVE EXISTING COVER AND HARDWARE TO BACK SIDE OF LIGHT MOUNT, BOTH SIDES.

DRILL COVER POSITIONS F13, F14, F17 & F18
Ø.445

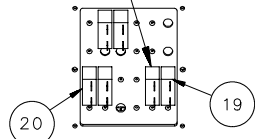

BREAKERS - VIEWED FROM REAR SIDE OF BREAKER BOX (2ND MOUNTING ONLY)

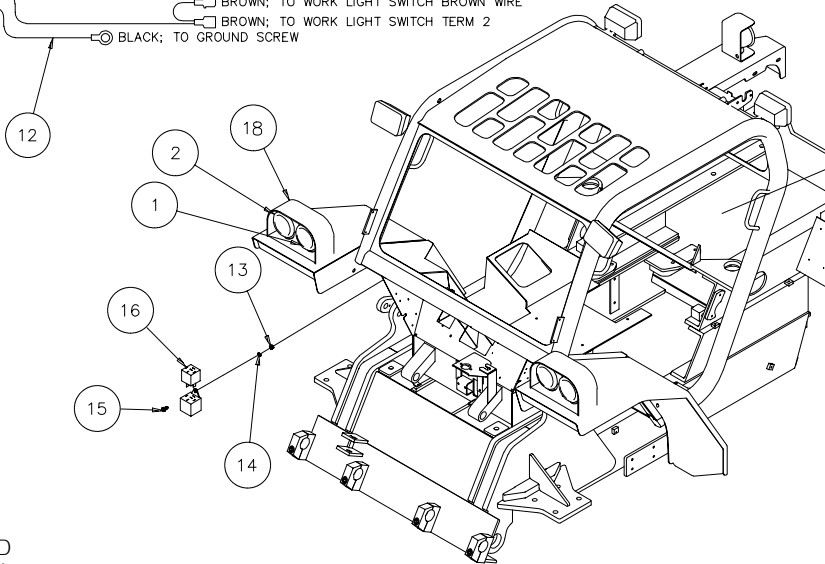
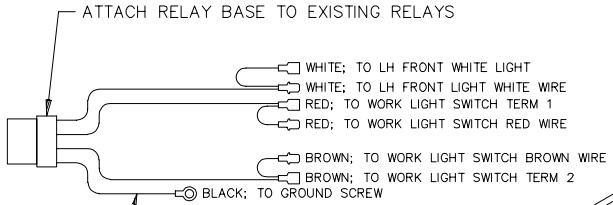

2ND MOUNTING

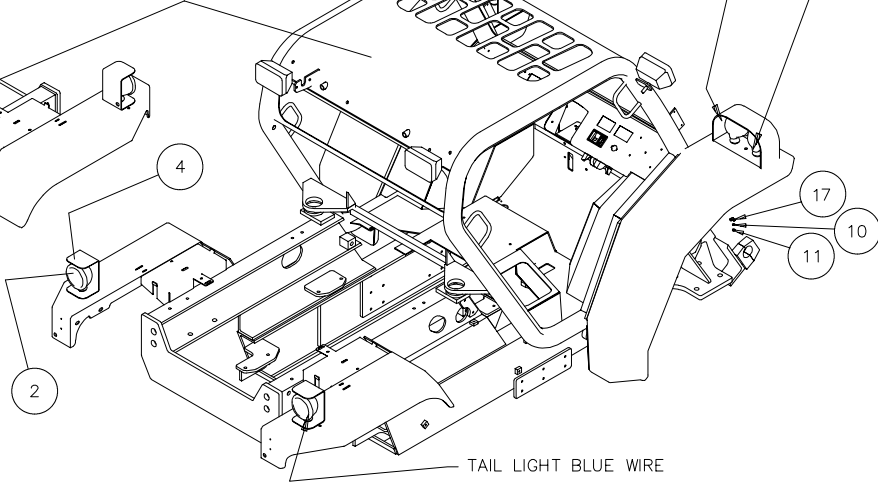

RED LIGHT ON LOW BEAM - YELLOW WIRE

WHITE LIGHT ON HIGH BEAM - WHITE WIRE

TAIL LIGHT BLUE WIRE

1	ELECTRICAL, POULTRY/BACK DOCK LIGHTING OPTION		QUANTITY / MODEL												11 BA 30			
			M30-4	M40-4	M50-4	M60-4	M30-4 H	M40-4 H	M50-4 H	M60-4 H	M30-4 L	M40-4 L	M50-4 L	M60-4 L	M30-4 H L	M40-4 H L	M50-4 H L	M60-4 H L
ITEM	PART NO.	DESCRIPTION	M30-2	M40-2	M50-2	M60-2	M30-2 H	M40-2 H	M50-2 H	M60-2 H	M30-2 L	M40-2 L	M50-2 L	M60-2 L	M30-2 H L	M40-2 H L	M50-2 H L	M60-2 H L
1	B3344	Light, white	A/R	A/R	A/R	A/R	A/R	A/R	A/R	A/R	A/R	A/R	A/R	A/R	A/R	A/R	A/R	A/R
2	B1335	Light, red	4	4	4	4	4	4	4	4	4	4	4	4	4	4	4	4
3	802649	Face plate	2	2	2	2	2	2	2	2	2	2	2	2	2	2	2	2
4	803061	Bracket, rear light	2	2	2	2	2	2	2	2	2	2	2	2	2	2	2	2
5	61674	Washer, flat	4	4	4	4	4	4	4	4	4	4	4	4	4	4	4	4
6	202731	Screw	4	4	4	4	4	4	4	4	4	4	4	4	4	4	4	4
7	42325	Washer, lock	4	4	4	4	4	4	4	4	4	4	4	4	4	4	4	4
8	58528	Nut	4	4	4	4	4	4	4	4	4	4	4	4	4	4	4	4
9	189172	Screw	4	4	4	4	4	4	4	4	4	4	4	4	4	4	4	4
10	42316	Washer, spring lock	4	4	4	4	4	4	4	4	4	4	4	4	4	4	4	4
11	25714	Nut	4	4	4	4	4	4	4	4	4	4	4	4	4	4	4	4
12	802133	Harness, poultry light	1	1	1	1	1	1	1	1	1	1	1	1	1	1	1	1
13	54232	Nut	1	1	1	1	1	1	1	1	1	1	1	1	1	1	1	1
14	28959	Washer, flat	1	1	1	1	1	1	1	1	1	1	1	1	1	1	1	1
15	79533	Screw	1	1	1	1	1	1	1	1	1	1	1	1	1	1	1	1
16	231244	Relay	1	1	1	1	1	1	1	1	1	1	1	1	1	1	1	1
17	B3698-2	Clamp	6	6	6	6	6	6	6	6	6	6	6	6	6	6	6	6
18	496680	Guard (without lamps)	2	2	2	2	2	2	2	2	2	2	2	2	2	2	2	2
19	804285	Circuit breaker, 5 amp	2	2	2	2	2	2	2	2	2	2	2	2	2	2	2	2
20	804287	Circuit breaker, 10 amp	2	2	2	2	2	2	2	2	2	2	2	2	2	2	2	2

11 BA 40

ELECTRICAL, WARNING BEACON OPTION

M30-2	M30-4	M30-2 H	M30-4 H
M40-2	M40-4	M40-2 H	M40-4 H
M50-2	M50-4	M50-2 H	M50-4 H
M60-2	M60-4	M60-2 H	M60-4 H
M30-2 L	M30-4 L	M30-2 H L	M30-4 H L
M40-2 L	M40-4 L	M40-2 H L	M40-4 H L
M50-2 L	M50-4 L	M50-2 H L	M50-4 H L
M60-2 L	M60-4 L	M60-2 H L	M60-4 H L

PRESS ONTO ITEM #3.
BEND TABS IN TO
TIGHTEN IF NECESSARY.

REMOVE AND DISCARD RUBBER
SEAL AND ALUMINUM INSERT.

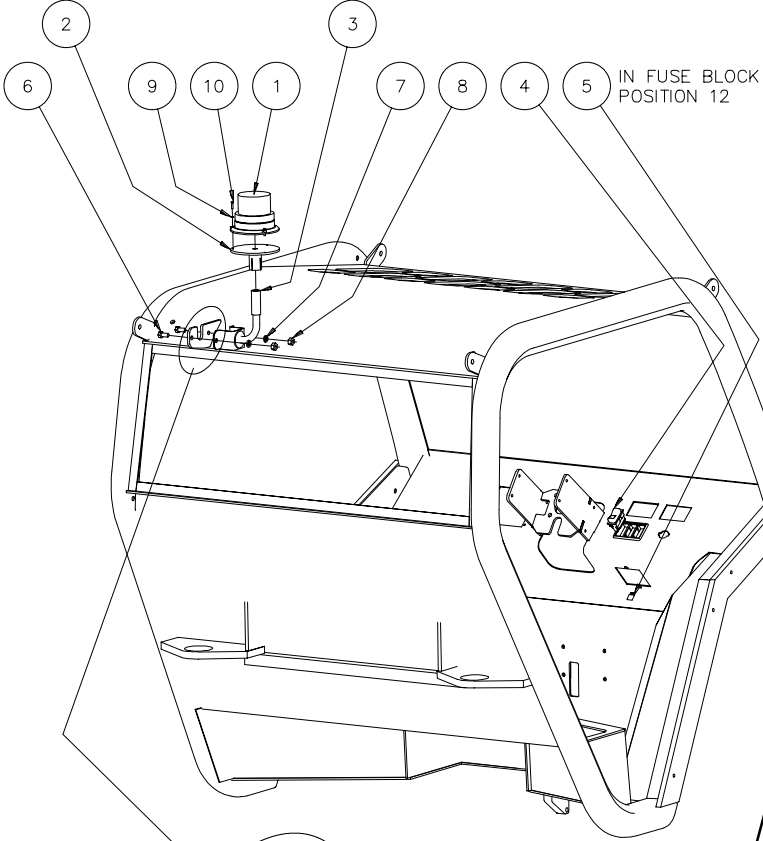

1ST MOUNTING

2ND MOUNTING

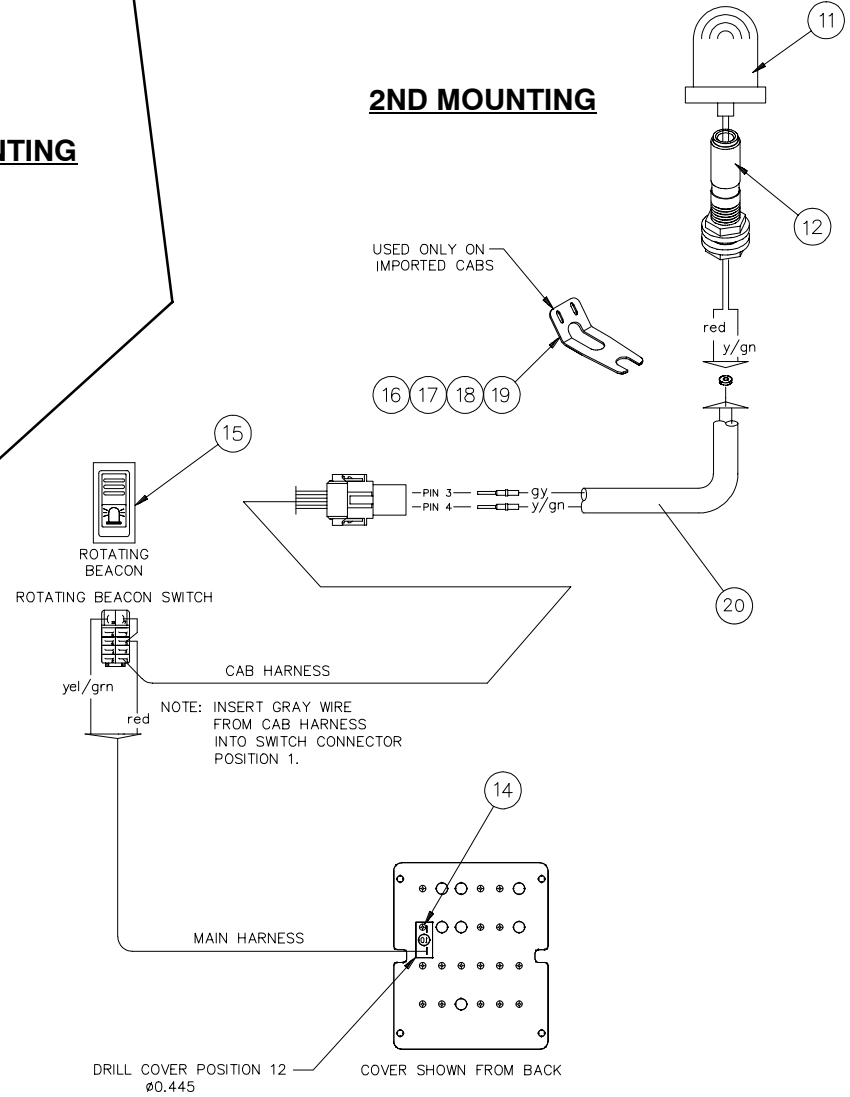

1	ELECTRICAL, WARNING BEACON OPTION		QUANTITY / MODEL											11 BA 40				
			M30-4	M40-4	M50-4	M60-4	M30-4 H	M40-4 H	M50-4 H	M60-4 H	M30-4 L	M40-4 L	M50-4 L	M60-4 L	M30-4 H L	M40-4 H L	M50-4 H L	M60-4 H L
ITEM	PART NO.	DESCRIPTION	M30-2	M40-2	M50-2	M60-2	M30-2 H	M40-2 H	M50-2 H	M60-2 H	M30-2 L	M40-2 L	M50-2 L	M60-2 L	M30-2 H L	M40-2 H L	M50-2 H L	M60-2 H L
1	802513	Strobe, amber	1	1	1	1	1	1	1	1	1	1	1	1	1	1	1	1
2	802514	Strobe mount	1	1	1	1	1	1	1	1	1	1	1	1	1	1	1	1
3	233341	Mount, beacon swivel	1	1	1	1	1	1	1	1	1	1	1	1	1	1	1	1
4	487962	Switch, beacon	1	1	1	1	1	1	1	1	1	1	1	1	1	1	1	1
5	173491	Fuse, 7.5 A	1	1	1	1	1	1	1	1	1	1	1	1	1	1	1	1
6	63727	Bolt	2	2	2	2	2	2	2	2	2	2	2	2	2	2	2	2
7	42232	Washer, lock	2	2	2	2	2	2	2	2	2	2	2	2	2	2	2	2
8	56354	Nut	2	2	2	2	2	2	2	2	2	2	2	2	2	2	2	2
9	28987	Washer, lock	3	3	3	3	3	3	3	3	3	3	3	3	3	3	3	3
10	61801	Bolt	3	3	3	3	3	3	3	3	3	3	3	3	3	3	3	3
11	224759	Rotating beacon	1	1	1	1	1	1	1	1	1	1	1	1	1	1	1	1
12	192415	Mounting kit (post)	1	1	1	1	1	1	1	1	1	1	1	1	1	1	1	1
14	804287	Circuit breaker, 10 amp	1	1	1	1	1	1	1	1	1	1	1	1	1	1	1	1
15	224768	Switch, beacon	1	1	1	1	1	1	1	1	1	1	1	1	1	1	1	1
16	231403	Plate, beacon mount	1	1	1	1	1	1	1	1	1	1	1	1	1	1	1	1
17	25713	Screw	2	2	2	2	2	2	2	2	2	2	2	2	2	2	2	2
18	189857	Washer	2	2	2	2	2	2	2	2	2	2	2	2	2	2	2	2
19	25714	Nut	2	2	2	2	2	2	2	2	2	2	2	2	2	2	2	2
20	804663	Harness, rotating beacon	1	1	1	1	1	1	1	1	1	1	1	1	1	1	1	1

11 CC 09

ELECTRICAL SWITCHES, SWITCH BOXES, BULBS, ETC.

M30-2	M30-4	M30-2 H	M30-4 H
M40-2	M40-4	M40-2 H	M40-4 H
M50-2	M50-4	M50-2 H	M50-4 H
M60-2	M60-4	M60-2 H	M60-4 H
M30-2 L	M30-4 L	M30-2 H L	M30-4 H L
M40-2 L	M40-4 L	M40-2 H L	M40-4 H L
M50-2 L	M50-4 L	M50-2 H L	M50-4 H L
M60-2 L	M60-4 L	M60-2 H L	M60-4 H L

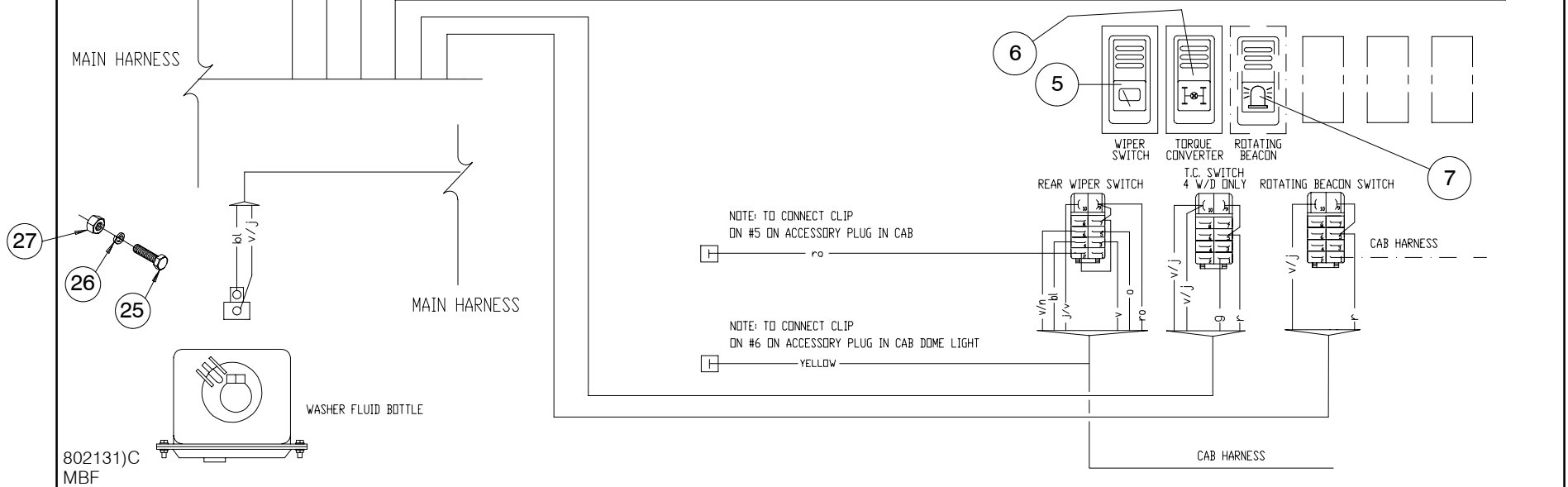
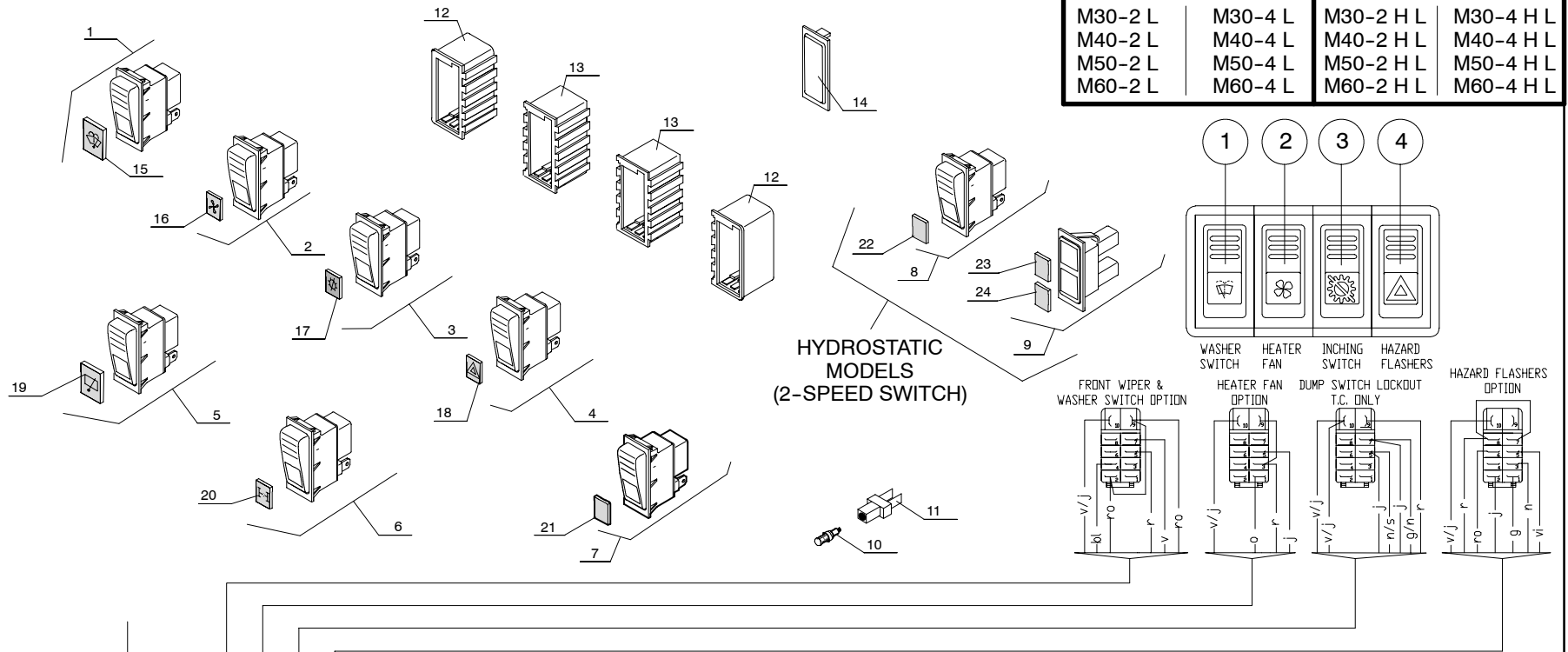

802131)C
MBF

1	ELECTRICAL SWITCHES, SWITCH BOXES, BULBS, ETC.		QUANTITY / MODEL											11 CC 09				
			M30-4	M40-4	M50-4	M60-4	M30-4 H	M40-4 H	M50-4 H	M60-4 H	M30-4 L	M40-4 L	M50-4 L	M60-4 L	M30-4 H L	M40-4 H L	M50-4 H L	M60-4 H L
ITEM	PART NO.	DESCRIPTION	M30-2	M40-2	M50-2	M60-2	M30-2 H	M40-2 H	M50-2 H	M60-2 H	M30-2 L	M40-2 L	M50-2 L	M60-2 L	M30-2 H L	M40-2 H L	M50-2 H L	M60-2 H L
1	224766	Switch, washer/wiper	1	1	1	1	1	1	1	1	1	1	1	1	1	1	1	1
2	231486	Switch, fan	1	1	1	1	1	1	1	1	1	1	1	1	1	1	1	1
3	224763	Switch, Inching	1	1	1	1	1	1	1	1	1	1	1	1	1	1	1	1
4	224767	Switch, hazard	1	1	1	1	1	1	1	1	1	1	1	1	1	1	1	1
5	224765	Switch, wiper	1	1	1	1	1	1	1	1	1	1	1	1	1	1	1	1
6	238065	Switch, torque converter	1	1	1	1					1	1	1	1				
7	224768	Switch, rotating beacon	1	1	1	1	1	1	1	1	1	1	1	1	1	1	1	1
8	233870	Switch, hi speed / low speed					1	1	1	1					1	1	1	1
9	231464	Indicator, slow/fast					1	1	1	1					1	1	1	1
10	170836	Light bulb	A/R	A/R	A/R	A/R	A/R	A/R	A/R	A/R	A/R	A/R	A/R	A/R	A/R	A/R	A/R	A/R
11	554629	Bulb holder	A/R	A/R	A/R	A/R	A/R	A/R	A/R	A/R	A/R	A/R	A/R	A/R	A/R	A/R	A/R	A/R
12	224774	Switch bracket/box (RH or LH)	A/R	A/R	A/R	A/R	A/R	A/R	A/R	A/R	A/R	A/R	A/R	A/R	A/R	A/R	A/R	A/R
13	224773	Switch bracket/box (center box)	A/R	A/R	A/R	A/R	A/R	A/R	A/R	A/R	A/R	A/R	A/R	A/R	A/R	A/R	A/R	A/R
14	224775	Blank switch plug	A/R	A/R	A/R	A/R	A/R	A/R	A/R	A/R	A/R	A/R	A/R	A/R	A/R	A/R	A/R	A/R
15	563798	Lens, washer/wiper	1	1	1	1	1	1	1	1	1	1	1	1	1	1	1	1
16	601679	Lens, fan	1	1	1	1	1	1	1	1	1	1	1	1	1	1	1	1
17	563800	Lens, torque converter	1	1	1	1					1	1	1	1				
18	563796	Lens, hazard	1	1	1	1	1	1	1	1	1	1	1	1	1	1	1	1
19	563799	Lens, wiper	1	1	1	1	1	1	1	1	1	1	1	1	1	1	1	1
20	603593	Lens, torque converter	1	1	1	1					1	1	1	1				
21	504389	Lens, rotating beacon	1	1	1	1	1	1	1	1	1	1	1	1	1	1	1	1
22	563794	Lens, toggle switch					1	1	1	1					1	1	1	1
23	601845	Lens, turtle					1	1	1	1					1	1	1	1
24	601846	Lens, rabbit					1	1	1	1					1	1	1	1
25	25713	Bolt	2	2	2	2	2	2	2	2	2	2	2	2	2	2	2	2
26	42316	Washer, lock	2	2	2	2	2	2	2	2	2	2	2	2	2	2	2	2
27	25714	Nut	2	2	2	2	2	2	2	2	2	2	2	2	2	2	2	2

11 CC 10

**CAB WIRING HARNESS, 77, 81, & 100 IN.
(WACO BUILT CABS ONLY)**

802861)E

**HARNESS PART NO. 802861
(1ST MOUNTING -
NO LONGER AVAILABLE)**

M30-2	M30-4	M30-2 H	M30-4 H
M40-2	M40-4	M40-2 H	M40-4 H
M50-2	M50-4	M50-2 H	M50-4 H
M60-2	M60-4	M60-2 H	M60-4 H
M30-2 L	M30-4 L	M30-2 H L	M30-4 H L
M40-2 L	M40-4 L	M40-2 H L	M40-4 H L
M50-2 L	M50-4 L	M50-2 H L	M50-4 H L
M60-2 L	M60-4 L	M60-2 H L	M60-4 H L

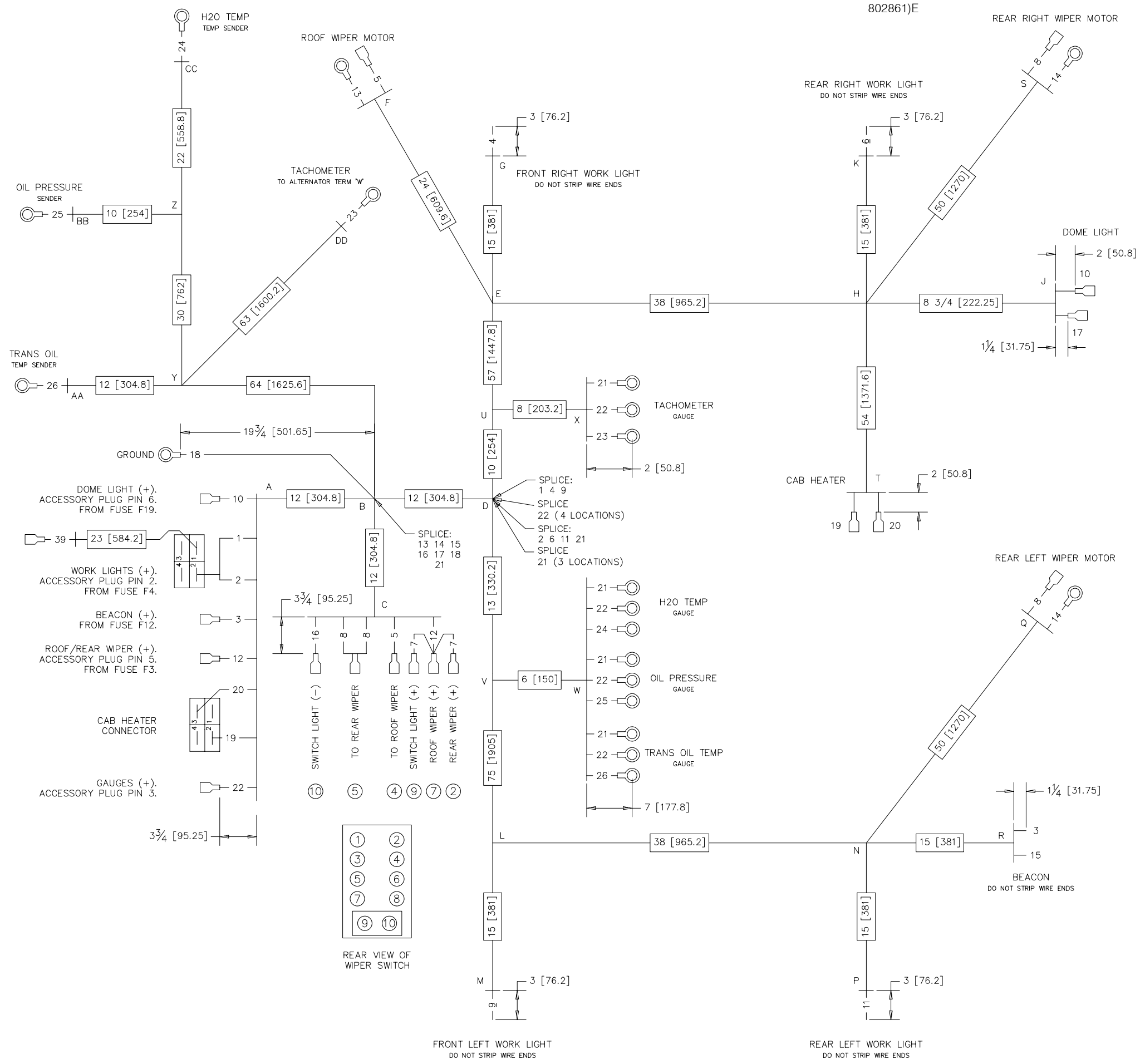

1ST MOUNTING (THIS PAGE)
2ND MOUNTING (FOLLOWING PAGE)

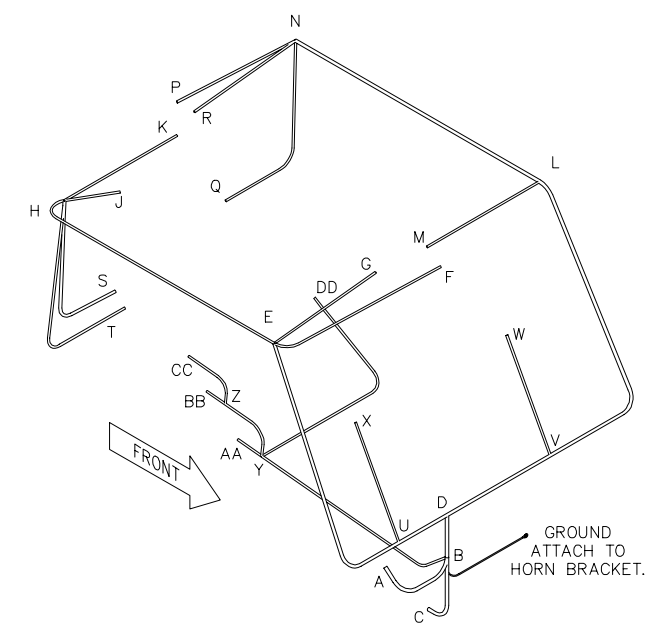

- NOTES:
1. DIMENSIONS ARE SHOWN INCH [MM].
 2. ALL SPLICES ARE TO BE SOLDERED AND TAPED MINIMUM OF TWO WRAPS.
 3. ALL HARNESS JUNCTIONS AND WIRE BREAKOUTS TO BE TAPED MINIMUM OF TWO WRAPS.
 4. NUMBERS AT OR NEAR TERMINATIONS ARE WIRE NUMBERS.
 5. TOLERANCES:
FOR LENGTHS ≤ TO 4": ±3/16"
FOR LENGTHS > 4" TO 20": ±3/8"
FOR LENGTHS > 20" TO 40": ±1/4"
FOR LENGTHS > 40": ±1/2"
 6. LENGTHS SHOWN IN PARTS LIST ARE APPROXIMATE AND MAY BE ADJUSTED AS NECESSARY TO ACHIEVE DIMENSIONS ON DRAWING.
 7. ALL CONNECTORS SHOWN FROM BACK OF CONNECTOR.

73.00

11 CC 10

CAB WIRING HARNESS, 77, 81, & 100 IN. (WACO BUILT CABS ONLY)

802861F

HARNESS PART NO. 802861
(CURRENT VERSION)

2ND MOUNTING

M30-2	M30-4	M30-2 H	M30-4 H
M40-2	M40-4	M40-2 H	M40-4 H
M50-2	M50-4	M50-2 H	M50-4 H
M60-2	M60-4	M60-2 H	M60-4 H
M30-2 L	M30-4 L	M30-2 H L	M30-4 H L
M40-2 L	M40-4 L	M40-2 H L	M40-4 H L
M50-2 L	M50-4 L	M50-2 H L	M50-4 H L
M60-2 L	M60-4 L	M60-2 H L	M60-4 H L

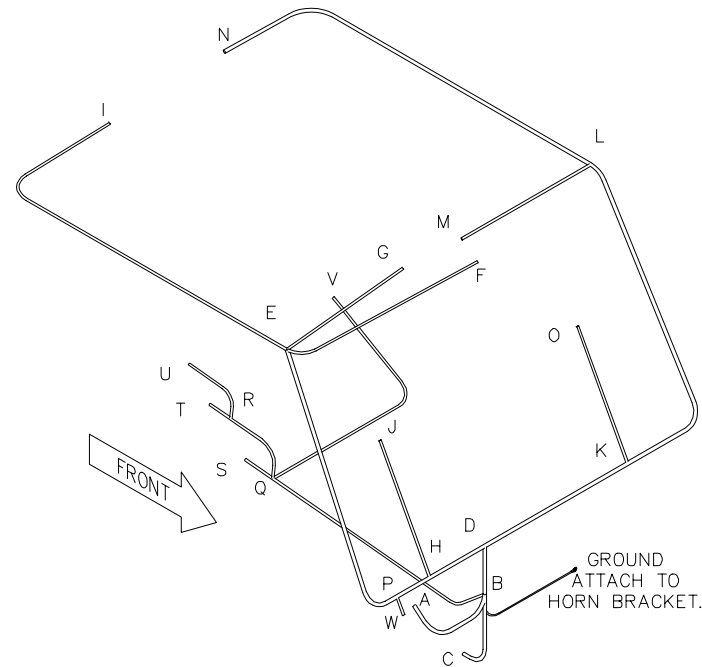
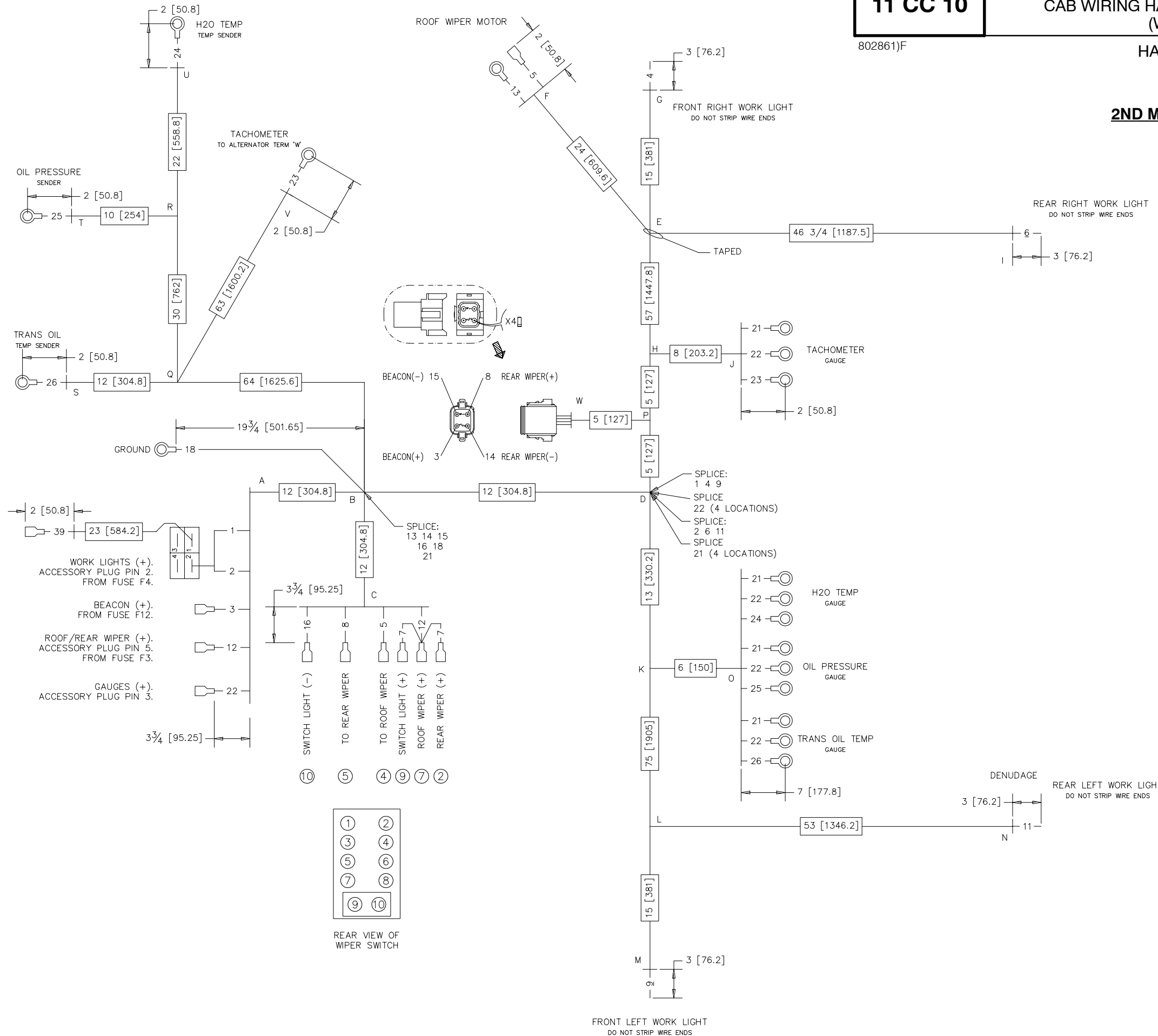

- NOTES:
- DIMENSIONS ARE SHOWN INCH [MM].
 - ALL SPLICES ARE TO BE SOLDERED AND TAPED MINIMUM OF TWO WRAPS.
 - ALL HARNESS JUNCTIONS AND WIRE BREAKOUTS TO BE TAPED MINIMUM OF TWO WRAPS.
 - NUMBERS AT OR NEAR TERMINATIONS ARE WIRE NUMBERS.
 - TOLERANCES:
FOR LENGTHS <= TO 4": ± $\frac{3}{16}$ "
FOR LENGTHS > 4" TO 20": ± $\frac{3}{8}$ "
FOR LENGTHS > 20" TO 40": ± $\frac{3}{4}$ "
FOR LENGTHS > 40": ±1 $\frac{1}{2}$ "
 - LENGTHS SHOWN IN PARTS LIST ARE APPROXIMATE AND MAY BE ADJUSTED AS NECESSARY TO ACHIEVE DIMENSIONS ON DRAWING.
 - ALL CONNECTORS SHOWN FROM BACK OF CONNECTOR.

11 CC 11

WINDSHIELD WIPER INSTALLATION, 100 IN. CAB (CAB 802656)

M30-2	M30-4	M30-2 H	M30-4 H
M40-2	M40-4	M40-2 H	M40-4 H
M50-2	M50-4	M50-2 H	M50-4 H
M60-2	M60-4	M60-2 H	M60-4 H
M30-2 L	M30-4 L	M30-2 H L	M30-4 H L
M40-2 L	M40-4 L	M40-2 H L	M40-4 H L
M50-2 L	M50-4 L	M50-2 H L	M50-4 H L
M60-2 L	M60-4 L	M60-2 H L	M60-4 H L

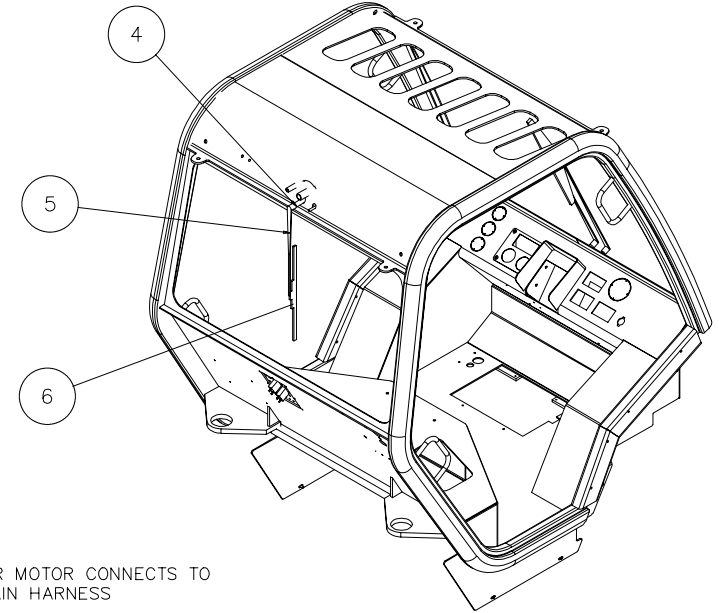
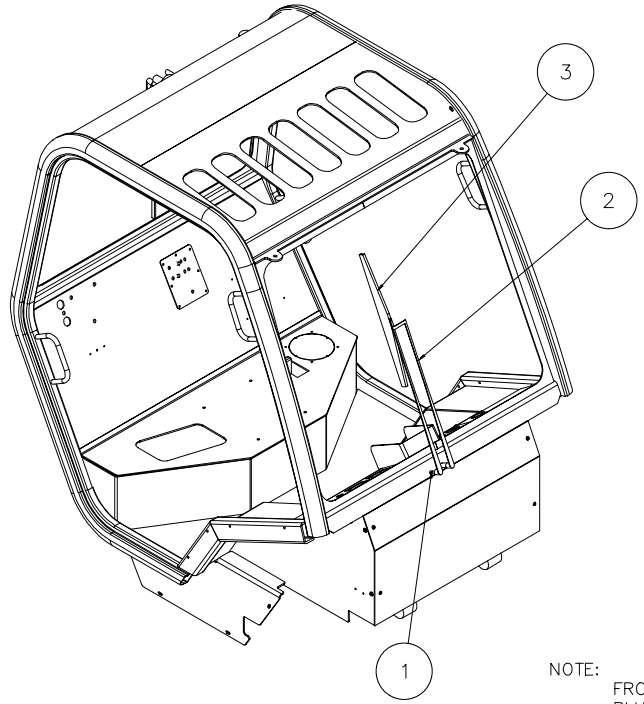

NOTE: FRONT WIPER MOTOR CONNECTS TO PLUG ON MAIN HARNESS

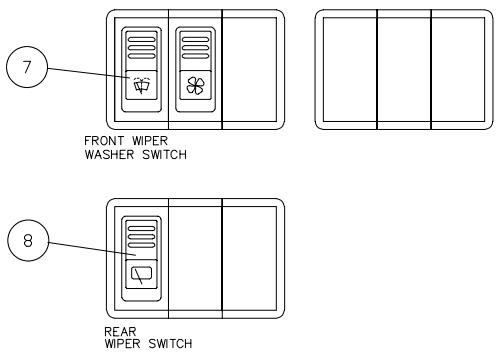

NOTE: USE 10 AMP FUSE IN POSITION 8 (11)
USE 7.5 AMP FUSE IN POSITION 3 (12)

ITEM	PART NO.	DESCRIPTION	QUANTITY / MODEL											11 CC 11				
			M30-2	M40-2	M50-2	M60-2	M30-2 H	M40-2 H	M50-2 H	M60-2 H	M30-2 L	M40-2 L	M50-2 L	M60-2 L	M30-2 H L	M40-2 H L	M50-2 H L	M60-2 H L
1		WINDSHIELD WIPER INSTALLATION, 100 IN. CAB (CAB 802656)	M30-4	M40-4	M50-4	M60-4	M30-4 H	M40-4 H	M50-4 H	M60-4 H	M30-4 L	M40-4 L	M50-4 L	M60-4 L	M30-4 H L	M40-4 H L	M50-4 H L	M60-4 H L
	803167	Windshield wiper installation (less Items 11 & 12)	1	1	1	1	1	1	1	1	1	1	1	1	1	1	1	1
1	803168	Motor, wiper	1	1	1	1	1	1	1	1	1	1	1	1	1	1	1	1
2	803169	Wiper arm	1	1	1	1	1	1	1	1	1	1	1	1	1	1	1	1
3	803170	Wiper blade	1	1	1	1	1	1	1	1	1	1	1	1	1	1	1	1
4	552760	Motor, wiper	1	1	1	1	1	1	1	1	1	1	1	1	1	1	1	1
5	184526	Wiper arm	1	1	1	1	1	1	1	1	1	1	1	1	1	1	1	1
6	54557	Wiper blade	1	1	1	1	1	1	1	1	1	1	1	1	1	1	1	1
7	224766	Switch	1	1	1	1	1	1	1	1	1	1	1	1	1	1	1	1
8	224765	Switch	1	1	1	1	1	1	1	1	1	1	1	1	1	1	1	1
11	177739	Fuse, 10 amp	1	1	1	1	1	1	1	1	1	1	1	1	1	1	1	1
12	173491	Fuse, 7.5 amp	1	1	1	1	1	1	1	1	1	1	1	1	1	1	1	1

11 CC 12

WINDSHIELD WIPER INSTALLATION, 77 & 81 IN. CAB

M30-2	M30-4	M30-2 H	M30-4 H
M40-2	M40-4	M40-2 H	M40-4 H
M50-2	M50-4	M50-2 H	M50-4 H
M60-2	M60-4	M60-2 H	M60-4 H
M30-2 L	M30-4 L	M30-2 H L	M30-4 H L
M40-2 L	M40-4 L	M40-2 H L	M40-4 H L
M50-2 L	M50-4 L	M50-2 H L	M50-4 H L
M60-2 L	M60-4 L	M60-2 H L	M60-4 H L

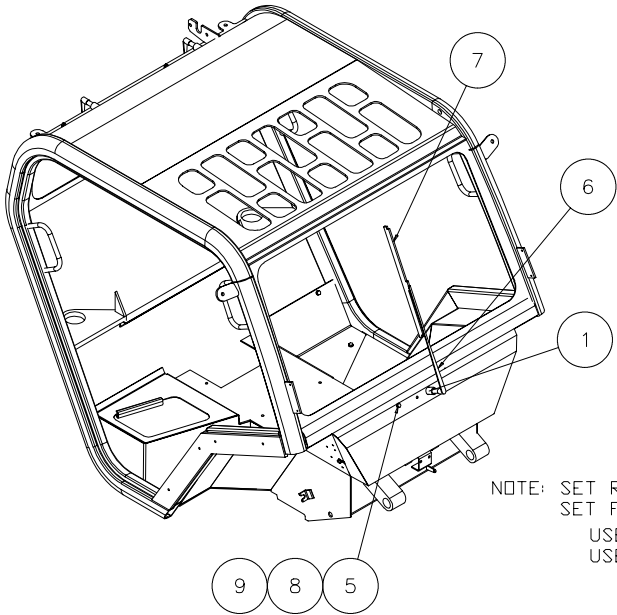

1ST MOUNTING

NOTE: SET REAR MOTORS TO 85°/65°
SET FRONT MOTOR TO 85°/65°

USE 10 AMP FUSE IN POSITION 8
USE 7.5 AMP FUSE IN POSITION 3

FRONT WIPER MOTOR CONNECTS TO
RED WIRE #2 IN PLUG ON MAIN
HARNESS

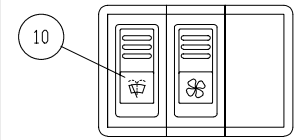
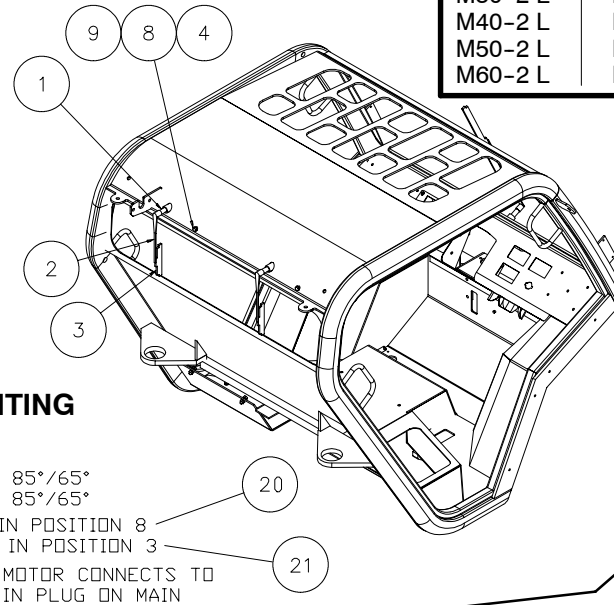

FRONT WIPER &
WASHER SWITCH

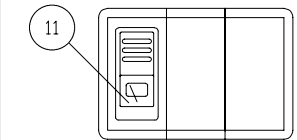

REAR
WIPER SWITCH

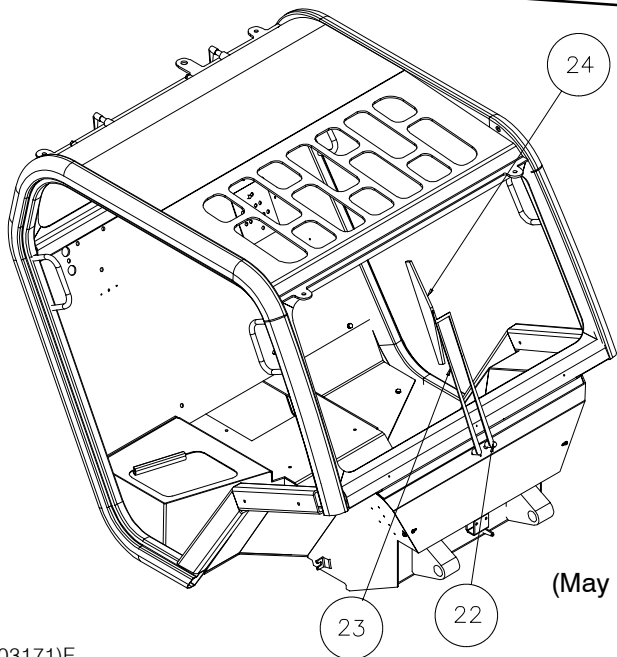

2ND MOUNTING (May use fuses or circuit breakers)

NOTE: SET REAR MOTORS TO 85°/65°

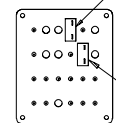
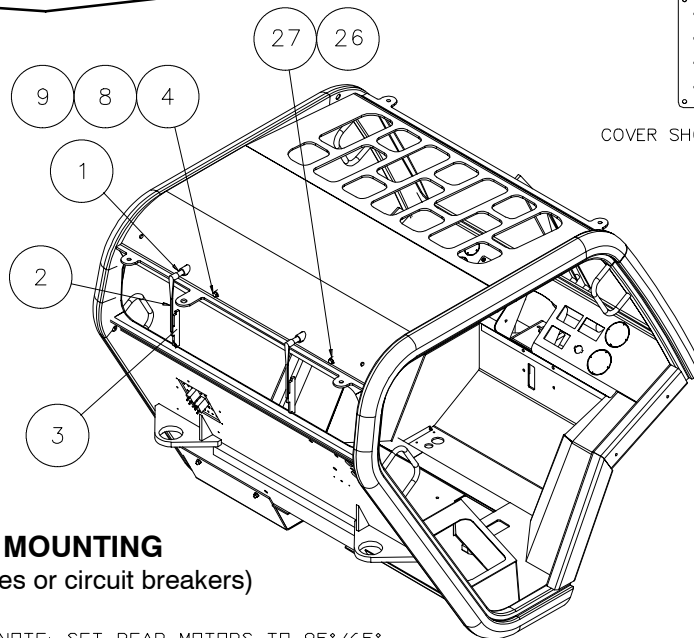

DRILL COVER POSITIONS
F3 & F8 ϕ 0.445

COVER SHOWN FROM BACK

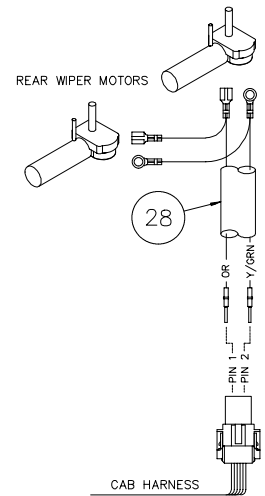

1	QUANTITY / MODEL													11 CC 12				
	M30-4	M40-4	M50-4	M60-4	M30-4 H	M40-4 H	M50-4 H	M60-4 H	M30-4 L	M40-4 L	M50-4 L	M60-4 L	M30-4 H L	M40-4 H L	M50-4 H L	M60-4 H L		
ITEM	PART NO.	DESCRIPTION	M30-2	M40-2	M50-2	M60-2	M30-2 H	M40-2 H	M50-2 H	M60-2 H	M30-2 L	M40-2 L	M50-2 L	M60-2 L	M30-2 H L	M40-2 H L	M50-2 H L	M60-2 H L
1	491718	Motor, wiper	A/R	A/R	A/R	A/R	A/R	A/R	A/R	A/R	A/R	A/R	A/R	A/R	A/R	A/R	A/R	A/R
2	803208	Wiper arm	2	2	2	2	2	2	2	2	2	2	2	2	2	2	2	2
3	803209	Wiper blade	2	2	2	2	2	2	2	2	2	2	2	2	2	2	2	2
4	58531	Bolt	2	2	2	2	2	2	2	2	2	2	2	2	2	2	2	2
5	63754	Bolt	1	1	1	1	1	1	1	1	1	1	1	1	1	1	1	1
6	491714	Wiper arm	1	1	1	1	1	1	1	1	1	1	1	1	1	1	1	1
7	803525	Wiper blade	1	1	1	1	1	1	1	1	1	1	1	1	1	1	1	1
8	61674	Washer, flat	6	6	6	6	6	6	6	6	6	6	6	6	6	6	6	6
9	58528	Nut	3	3	3	3	3	3	3	3	3	3	3	3	3	3	3	3
10	224766	Switch	1	1	1	1	1	1	1	1	1	1	1	1	1	1	1	1
11	224765	Switch	1	1	1	1	1	1	1	1	1	1	1	1	1	1	1	1
19	803202	Wiper blade	1	1	1	1	1	1	1	1	1	1	1	1	1	1	1	1
20	177739	Fuse, 10 amp	1	1	1	1	1	1	1	1	1	1	1	1	1	1	1	1
21	173491	Fuse, 7.5 amp	1	1	1	1	1	1	1	1	1	1	1	1	1	1	1	1
22	803168	Motor, wiper	1	1	1	1	1	1	1	1	1	1	1	1	1	1	1	1
23	803201	Wiper arm	1	1	1	1	1	1	1	1	1	1	1	1	1	1	1	1
24	803202	Wiper blade	1	1	1	1	1	1	1	1	1	1	1	1	1	1	1	1
25	804287	Circuit breaker, 10 amp	2	2	2	2	2	2	2	2	2	2	2	2	2	2	2	2
26	804024	Spacer	2	2	2	2	2	2	2	2	2	2	2	2	2	2	2	2
27	804025	Spacer	2	2	2	2	2	2	2	2	2	2	2	2	2	2	2	2
28	804665	Harness, wiper	1	1	1	1	1	1	1	1	1	1	1	1	1	1	1	1

11 CC 13

TACHOMETER OPTION

M30-2	M30-4	M30-2 H	M30-4 H
M40-2	M40-4	M40-2 H	M40-4 H
M50-2	M50-4	M50-2 H	M50-4 H
M60-2	M60-4	M60-2 H	M60-4 H
M30-2 L	M30-4 L	M30-2 H L	M30-4 H L
M40-2 L	M40-4 L	M40-2 H L	M40-4 H L
M50-2 L	M50-4 L	M50-2 H L	M50-4 H L
M60-2 L	M60-4 L	M60-2 H L	M60-4 H L

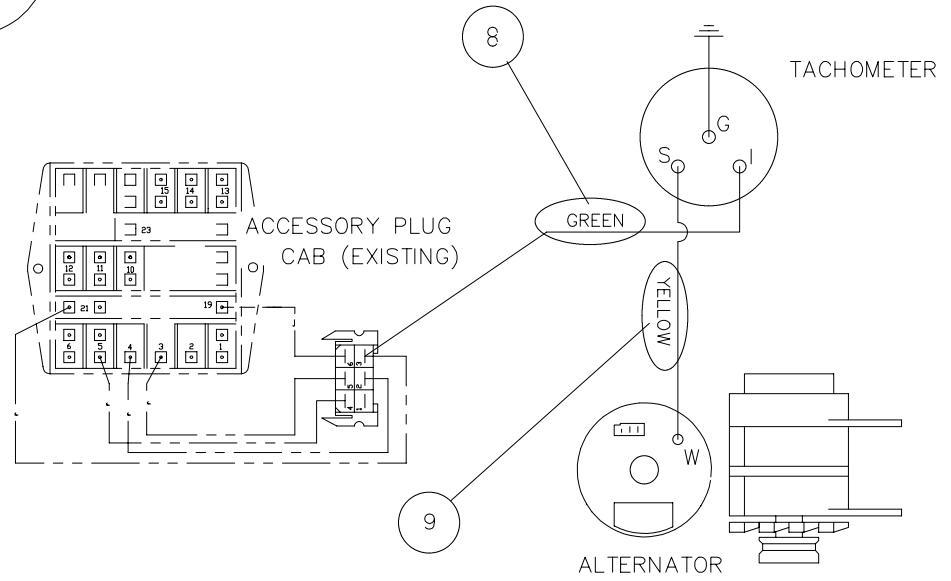
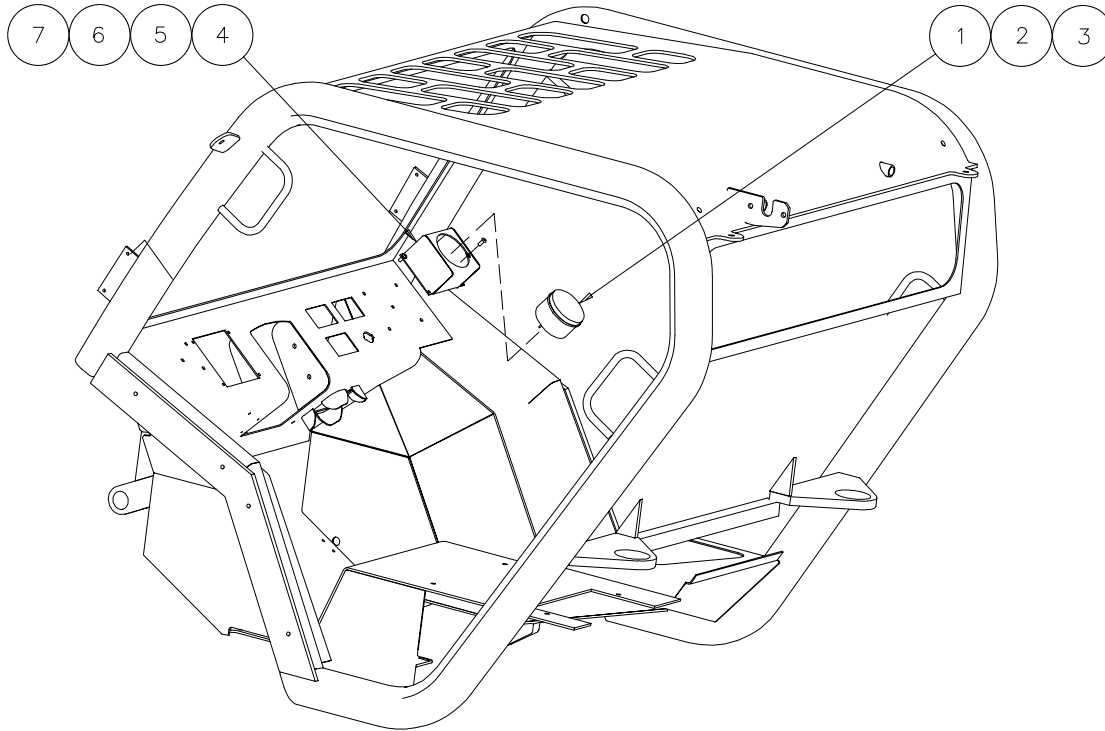

1	TACHOMETER OPTION		QUANTITY / MODEL												11 CC 13			
			M30-4	M40-4	M50-4	M60-4	M30-4 H	M40-4 H	M50-4 H	M60-4 H	M30-4 L	M40-4 L	M50-4 L	M60-4 L	M30-4 H L	M40-4 H L	M50-4 H L	M60-4 H L
ITEM	PART NO.	DESCRIPTION	M30-2	M40-2	M50-2	M60-2	M30-2 H	M40-2 H	M50-2 H	M60-2 H	M30-2 L	M40-2 L	M50-2 L	M60-2 L	M30-2 H L	M40-2 H L	M50-2 H L	M60-2 H L
1	425514	Gauge, tachometer	1	1	1	1	1	1	1	1	1	1	1	1	1	1	1	1
2	424359	Kit, tach mount	1	1	1	1	1	1	1	1	1	1	1	1	1	1	1	1
3	424443	Kit, tach light	1	1	1	1	1	1	1	1	1	1	1	1	1	1	1	1
4*	803396	Gauge panel, tach	1	1	1	1	1	1	1	1	1	1	1	1	1	1	1	1
5*	29469	Washer, flat	4	4	4	4	4	4	4	4	4	4	4	4	4	4	4	4
6*	189172	Screw, cap	4	4	4	4	4	4	4	4	4	4	4	4	4	4	4	4
7*	25714	Nut	4	4	4	4	4	4	4	4	4	4	4	4	4	4	4	4
8*	803486	Harness, tach power	1	1	1	1	1	1	1	1	1	1	1	1	1	1	1	1
9*	803487	Harness, tachometer	1	1	1	1	1	1	1	1	1	1	1	1	1	1	1	1
		* 1ST MOUNTING components required on early model forklifts which do not have the tach cut-out on the dash or proper wiring.																

11 CC 14

GAUGES, OIL TEMP, OIL PRESS, WATER TEMP

M30-2	M30-4	M30-2 H	M30-4 H
M40-2	M40-4	M40-2 H	M40-4 H
M50-2	M50-4	M50-2 H	M50-4 H
M60-2	M60-4	M60-2 H	M60-4 H
M30-2 L	M30-4 L	M30-2 H L	M30-4 H L
M40-2 L	M40-4 L	M40-2 H L	M40-4 H L
M50-2 L	M50-4 L	M50-2 H L	M50-4 H L
M60-2 L	M60-4 L	M60-2 H L	M60-4 H L

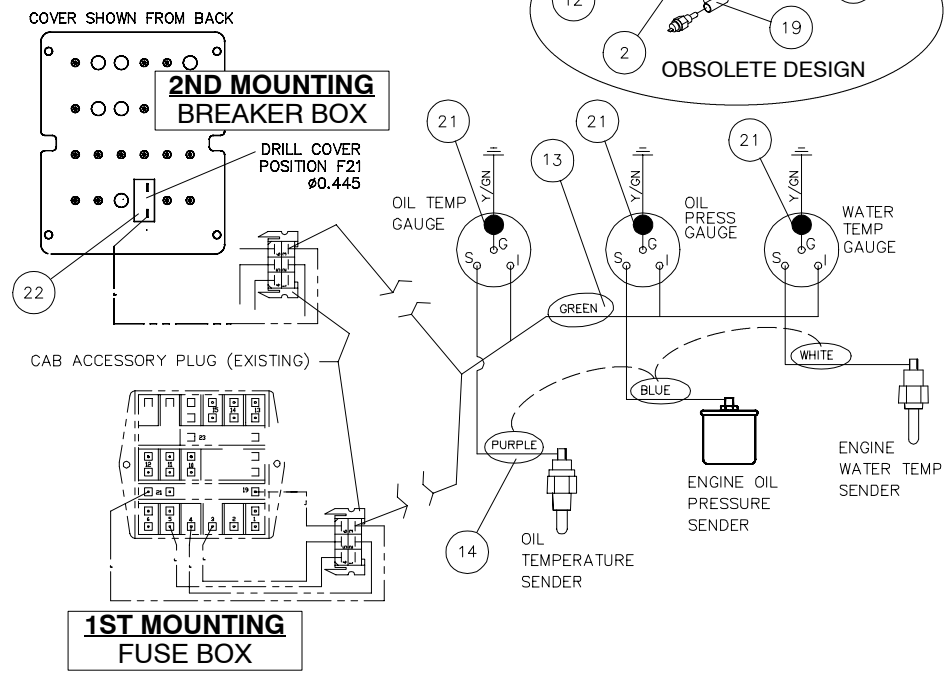
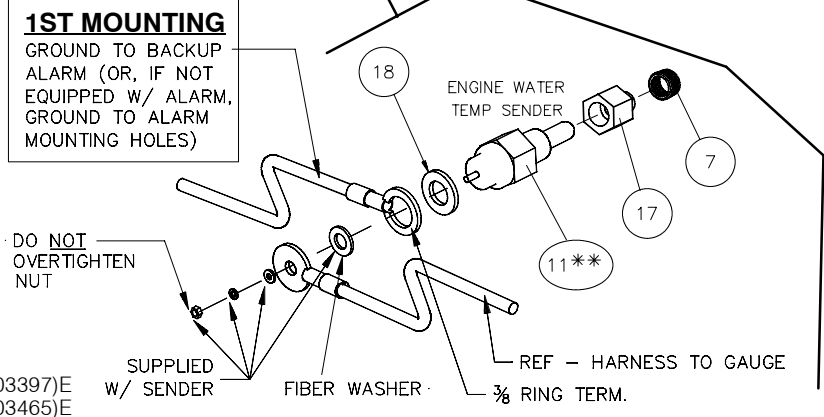
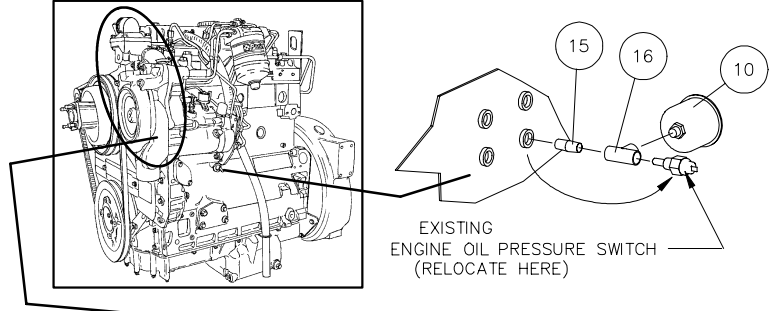
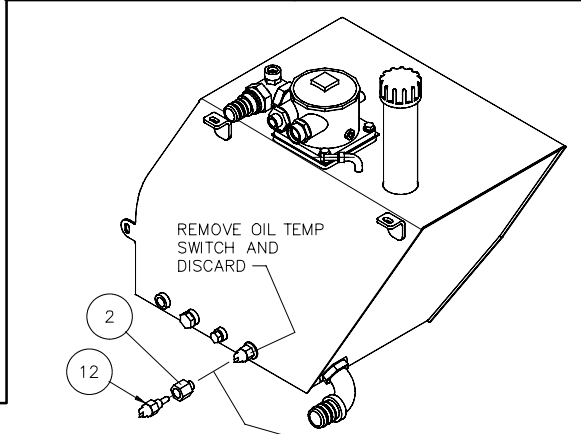
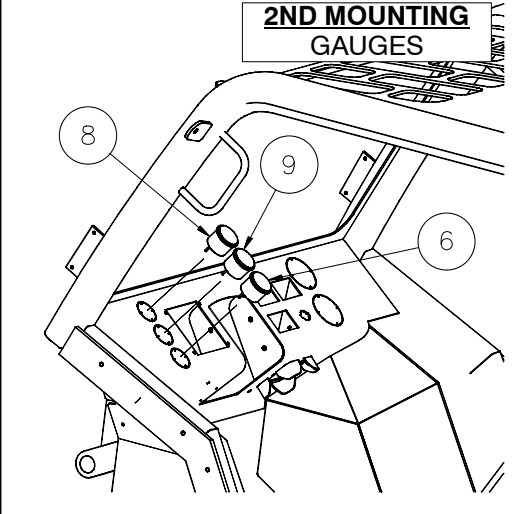
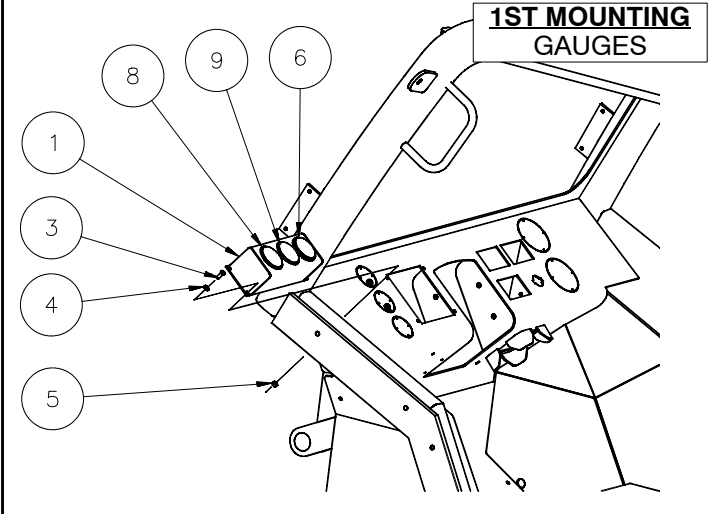

803397)E
803465)E

1	GAUGES, OIL TEMP, OIL PRESS, WATER TEMP		QUANTITY / MODEL											11 CC 14				
			M30-4	M40-4	M50-4	M60-4	M30-4 H	M40-4 H	M50-4 H	M60-4 H	M30-4 L	M40-4 L	M50-4 L	M60-4 L	M30-4 H L	M40-4 H L	M50-4 H L	M60-4 H L
ITEM	PART NO.	DESCRIPTION	M30-2	M40-2	M50-2	M60-2	M30-2 H	M40-2 H	M50-2 H	M60-2 H	M30-2 L	M40-2 L	M50-2 L	M60-2 L	M30-2 H L	M40-2 H L	M50-2 H L	M60-2 H L
1*	803399	Gauge panel	1	1	1	1	1	1	1	1	1	1	1	1	1	1	1	1
2	803412	Adapter	1	1	1	1	1	1	1	1	1	1	1	1	1	1	1	1
3*	189172	Screw	4	4	4	4	4	4	4	4	4	4	4	4	4	4	4	4
4*	29469	Washer, flat	4	4	4	4	4	4	4	4	4	4	4	4	4	4	4	4
5*	25714	Nut	4	4	4	4	4	4	4	4	4	4	4	4	4	4	4	4
6	803865	Gauge, oil temp	1	1	1	1	1	1	1	1	1	1	1	1	1	1	1	1
7	803866	Face fitting - 1ST MOUNTING ONLY	1	1	1	1	1	1	1	1	1	1	1	1	1	1	1	1
8	803863	Gauge, oil pressure	1	1	1	1	1	1	1	1	1	1	1	1	1	1	1	1
9	803864	Gauge, water temp	1	1	1	1	1	1	1	1	1	1	1	1	1	1	1	1
10	800964	Sender, oil pressure	1	1	1	1	1	1	1	1	1	1	1	1	1	1	1	1
11**	491913	Sender, water temp	1	1	1	1	1	1	1	1	1	1	1	1	1	1	1	1
12	423309	Sender, oil temp	1	1	1	1	1	1	1	1	1	1	1	1	1	1	1	1
13*	803416	Harness, power	1	1	1	1	1	1	1	1	1	1	1	1	1	1	1	1
14*	803415	Harness, H2O, oil temp, oil press	1	1	1	1	1	1	1	1	1	1	1	1	1	1	1	1
15	B116A1-7/8	Pipe nipple	1	1	1	1	1	1	1	1	1	1	1	1	1	1	1	1
16	803872	Tee	1	1	1	1	1	1	1	1	1	1	1	1	1	1	1	1
17	803871	Adapter	1	1	1	1	1	1	1	1	1	1	1	1	1	1	1	1
18	61676	Washer	1	1	1	1	1	1	1	1	1	1	1	1	1	1	1	1
19	K225-6	Female pipe tee	1	1	1	1	1	1	1	1	1	1	1	1	1	1	1	1
20	B116A3-5	Pipe nipple, 5 in. lg.	1	1	1	1	1	1	1	1	1	1	1	1	1	1	1	1
21	B5764	Light kit, gauge	A/R	A/R	A/R	A/R	A/R	A/R	A/R	A/R	A/R	A/R	A/R	A/R	A/R	A/R	A/R	A/R
22	804287	Circuit breaker, 10 amp	1	1	1	1	1	1	1	1	1	1	1	1	1	1	1	1

* These components required on early model forklifts which do not have cut-outs for the gauges or the proper wiring.

** 1ST MOUNTING - Mounts below water outlet.
2ND MOUNTING - Mounts behind water pump.

11 CD 10

ENGINE SHUTDOWN KIT

M30-2	M30-4	M30-2 H	M30-4 H
M40-2	M40-4	M40-2 H	M40-4 H
M50-2	M50-4	M50-2 H	M50-4 H
M60-2	M60-4	M60-2 H	M60-4 H
M30-2 L	M30-4 L	M30-2 H L	M30-4 H L
M40-2 L	M40-4 L	M40-2 H L	M40-4 H L
M50-2 L	M50-4 L	M50-2 H L	M50-4 H L
M60-2 L	M60-4 L	M60-2 H L	M60-4 H L

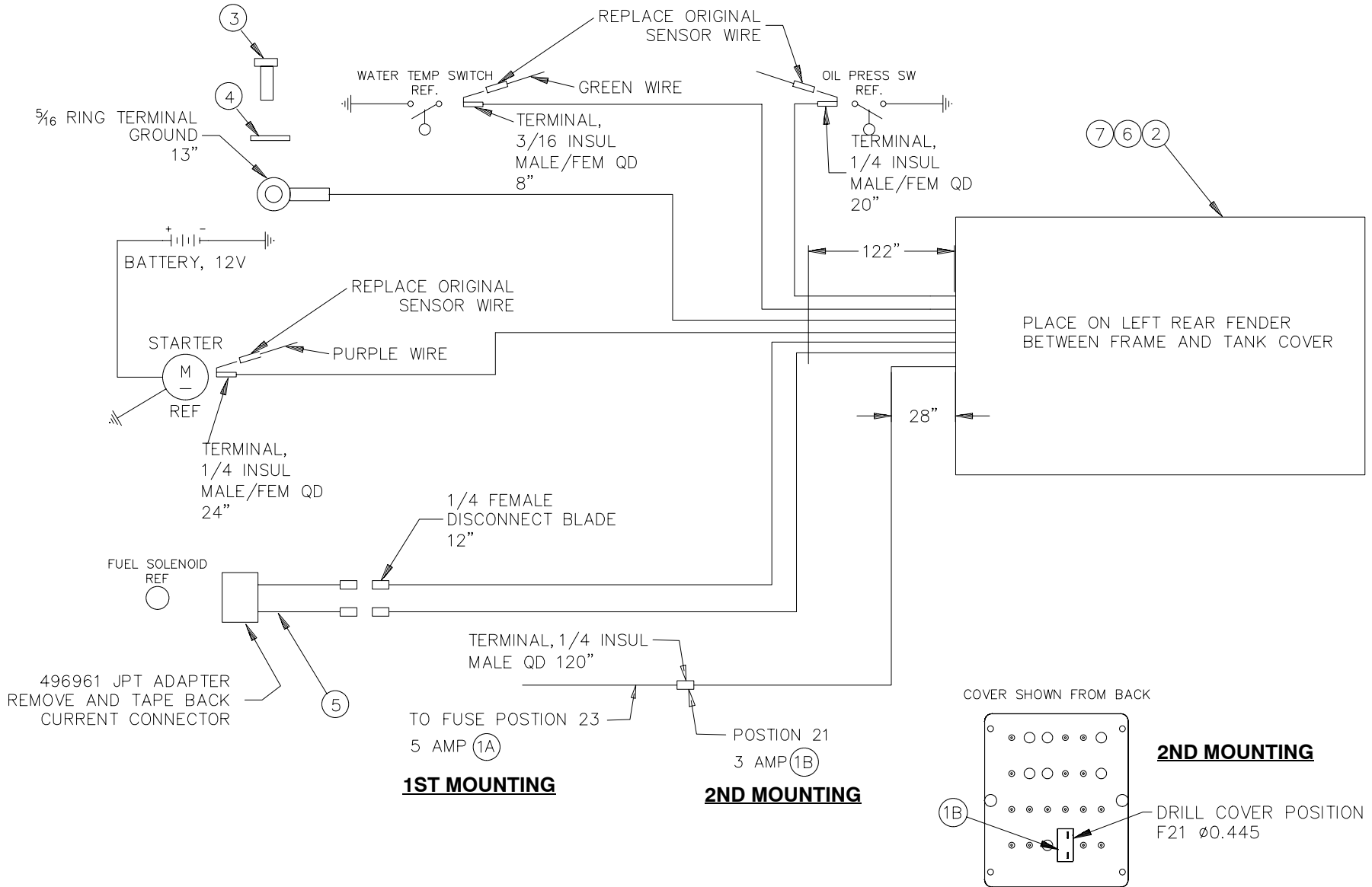

1	ENGINE SHUTDOWN KIT			QUANTITY / MODEL										11 CD 10				
				M30-4	M40-4	M50-4	M60-4	M30-4 H	M40-4 H	M50-4 H	M60-4 H	M30-4 L	M40-4 L	M50-4 L	M60-4 L	M30-4 H L	M40-4 H L	M50-4 H L
ITEM	PART NO.	DESCRIPTION	M30-2	M40-2	M50-2	M60-2	M30-2 H	M40-2 H	M50-2 H	M60-2 H	M30-2 L	M40-2 L	M50-2 L	M60-2 L	M30-2 H L	M40-2 H L	M50-2 H L	M60-2 H L
1A	207007	Fuse, 5 amp - 1ST MOUNTING	1	1	1	1	1	1	1	1	1	1	1	1	1	1	1	1
1B	804284	Circuit breaker, 3 amp - 2ND MOUNTING	1	1	1	1	1	1	1	1	1	1	1	1	1	1	1	1
2	802720	Shut down module	1	1	1	1	1	1	1	1	1	1	1	1	1	1	1	1
3	54951	Bolt	1	1	1	1	1	1	1	1	1	1	1	1	1	1	1	1
4	61674	Washer, flat	1	1	1	1	1	1	1	1	1	1	1	1	1	1	1	1
5	496961	JPT adapter	1	1	1	1	1	1	1	1	1	1	1	1	1	1	1	1
6	803450	Screw	4	4	4	4	4	4	4	4	4	4	4	4	4	4	4	4
7	28987	Washer, lock	4	4	4	4	4	4	4	4	4	4	4	4	4	4	4	4

HYDROSTATIC GEARBOX SOLENOID HARNESS

M30-2 H	M30-4 H
M40-2 H	M40-4 H
M50-2 H	M50-4 H
M60-2 H	M60-4 H
M30-2 H L	M30-4 H L
M40-2 H L	M40-4 H L
M50-2 H L	M50-4 H L
M60-2 H L	M60-4 H L

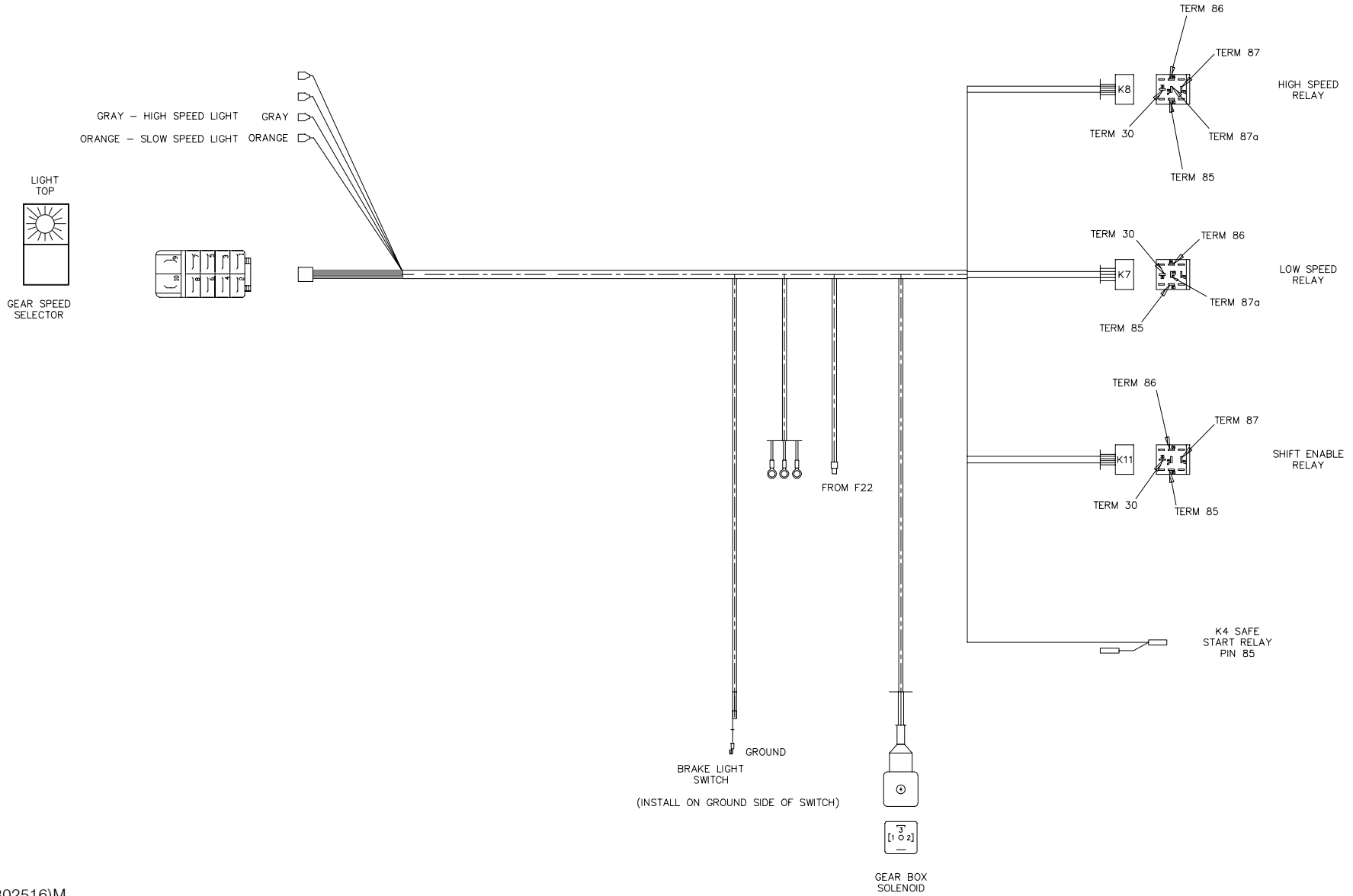

1	HYDROSTATIC GEARBOX SOLENOID HARNESS		QUANTITY / MODEL								11 CD 20							
							M30-4 H	M40-4 H	M50-4 H	M60-4 H					M30-4 H L	M40-4 H L	M50-4 H L	M60-4 H L
ITEM	PART NO.	DESCRIPTION					M30-2 H	M40-2 H	M50-2 H	M60-2 H					M30-2 H L	M40-2 H L	M50-2 H L	M60-2 H L
	802516	Wire harness, hydrostatic gearbox solenoid					1	1	1	1					1	1	1	1

11 CD 30

DRIVE AXLE OIL COOLER I (TORQUE CONVERTER OPTION)

M30-2	M30-4		
M40-2	M40-4		
M50-2	M50-4		
M60-2	M60-4		
M30-2 L	M30-4 L		
M40-2 L	M40-4 L		
M50-2 L	M50-4 L		
M60-2 L	M60-4 L		

1ST MOUNTING S/N: 750810 & BELOW

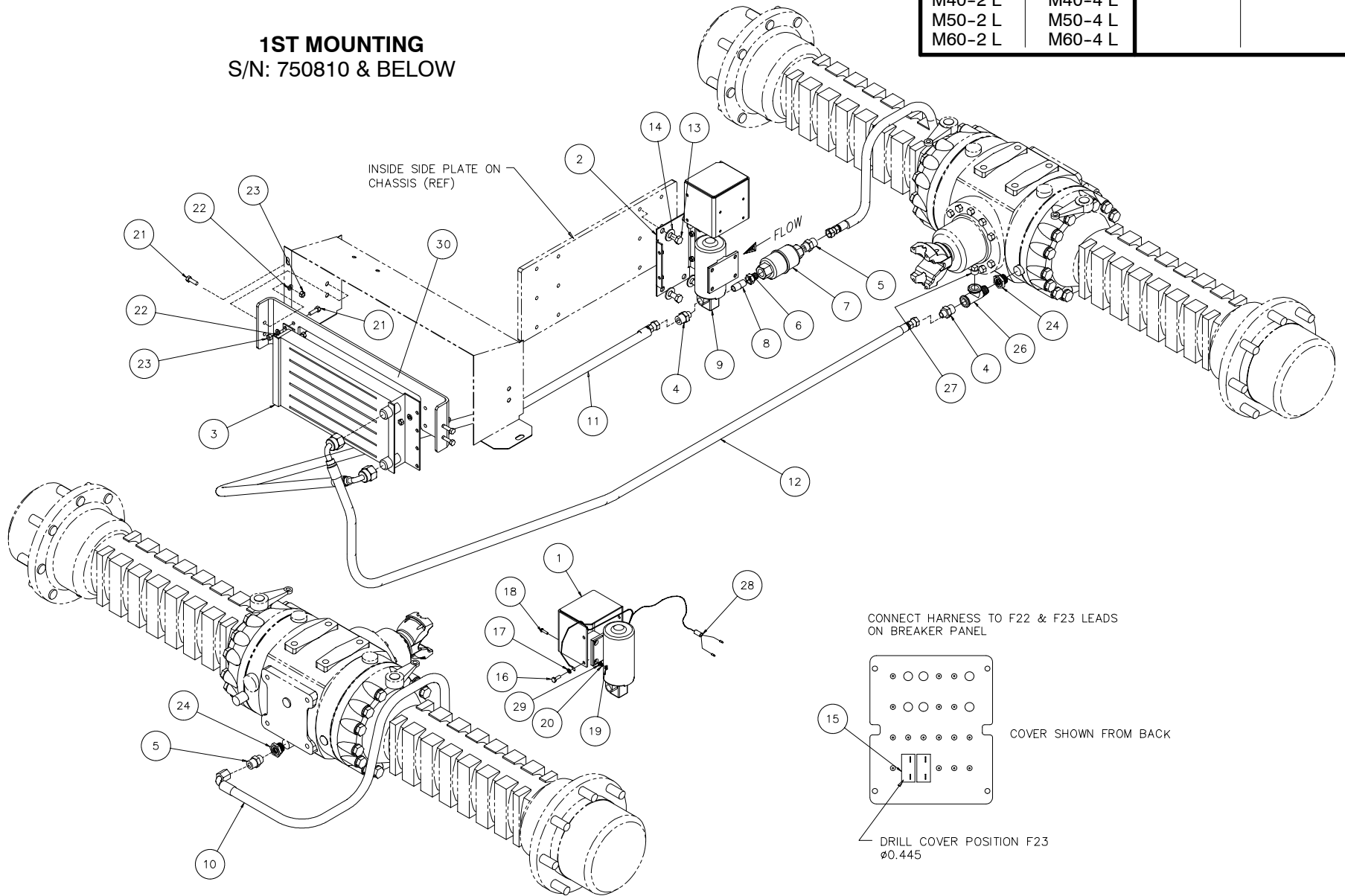

1	DRIVE AXLE OIL COOLER I (TORQUE CONVERTER OPTION)		QUANTITY / MODEL											11 CD 30					
			M30-4	M40-4	M50-4	M60-4					M30-4 L	M40-4 L	M50-4 L	M60-4 L					
ITEM	PART NO.	DESCRIPTION	M30-2	M40-2	M50-2	M60-2						M30-2 L	M40-2 L	M50-2 L	M60-2 L				
1	803992	Pump/motor cover	1	1	1	1						1	1	1	1				
2	803994	Mount, pump/motor	1	1	1	1						1	1	1	1				
3	424282	Cooler, trans oil	1	1	1	1						1	1	1	1				
4	425495	Adapter	3	3	3	3						3	3	3	3				
5	425494	Adapter	2	2	2	2						2	2	2	2				
6	B109A34	Bushing	2	2	2	2						2	2	2	2				
7	425481	Filter	1	1	1	1						1	1	1	1				
8	B116A3-15	Nipple	1	1	1	1						1	1	1	1				
9	803998	Pump/motor assembly	1	1	1	1						1	1	1	1				
10	425520	Hose assembly	1	1	1	1						1	1	1	1				
11	804043	Hose assembly	1	1	1	1						1	1	1	1				
12	425523	Hose assembly	1	1	1	1						1	1	1	1				
13	KN605557	Bolt	4	4	4	4						4	4	4	4				
14	K34809	Washer	4	4	4	4						4	4	4	4				
15	804287	Circuit breaker, 10 Amp	2	2	2	2						2	2	2	2				
16	K20344	Bolt	4	4	4	4						4	4	4	4				
17	K34805	Washer	4	4	4	4						4	4	4	4				
18	K54351SS	Screw	4	4	4	4						4	4	4	4				
19	K34053	Nut	4	4	4	4						4	4	4	4				
20	K34779	Washer	4	4	4	4						4	4	4	4				
21	K20386	Bolt	8	8	8	8						8	8	8	8				
22	K34806	Washer	8	8	8	8						8	8	8	8				
23	K33797	Nut	8	8	8	8						8	8	8	8				
24	425493	Adapter	3	3	3	3						3	3	3	3				
26	K224-6	Tee	1	1	1	1						1	1	1	1				
27	B114A3	Plug	1	1	1	1						1	1	1	1				
28	804050	Harness, pump/motor	1	1	1	1						1	1	1	1				
29	29469	Washer	4	4	4	4						4	4	4	4				
30	803991	Cooler mount	1	1	1	1						1	1	1	1				

11 CD 31

DRIVE AXLE OIL COOLER II (TORQUE CONVERTER OPTION)

M30-2	M30-4		
M40-2	M40-4		
M50-2	M50-4		
M60-2	M60-4		
M30-2 L	M30-4 L		
M40-2 L	M40-4 L		
M50-2 L	M50-4 L		
M60-2 L	M60-4 L		

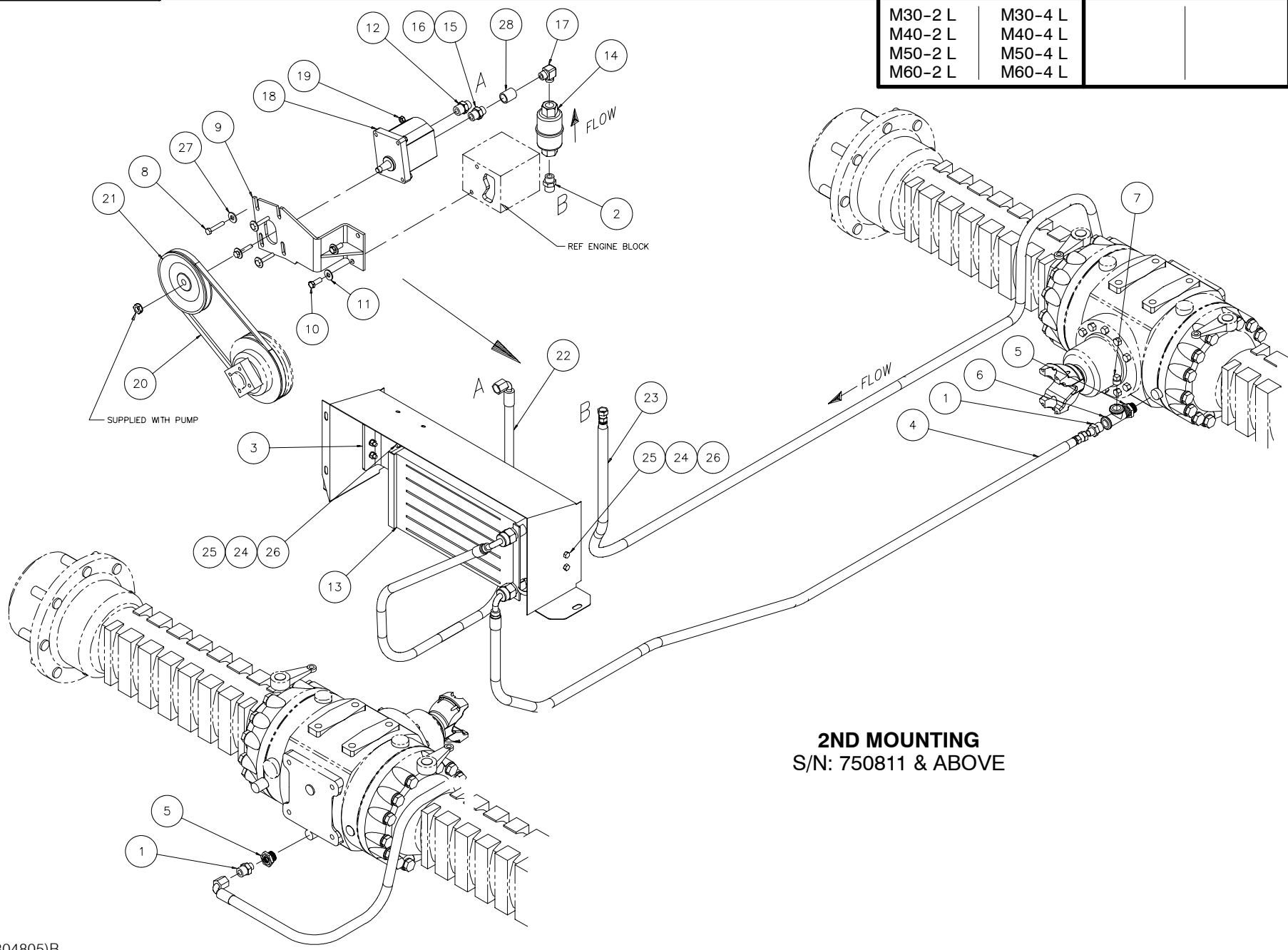

2ND MOUNTING
S/N: 750811 & ABOVE

			QUANTITY / MODEL											11 CD 31				
1 DRIVE AXLE OIL COOLER II (TORQUE CONVERTER OPTION)			M30-4	M40-4	M50-4	M60-4					M30-4 L	M40-4 L	M50-4 L	M60-4 L				
ITEM	PART NO.	DESCRIPTION	M30-2	M40-2	M50-2	M60-2					M30-2 L	M40-2 L	M50-2 L	M60-2 L				
1	425495	Adapter	1	1	1	1					1	1	1	1				
2*	425494	Adapter	2	2	2	2					2	2	2	2				
3	803991	Cooler mount	1	1	1	1					1	1	1	1				
4	805098	Hose assembly	1	1	1	1					1	1	1	1				
5	425493	Adapter	2	2	2	2					2	2	2	2				
6	K224-6	Tee	1	1	1	1					1	1	1	1				
7	B114A3	Plug	1	1	1	1					1	1	1	1				
8*	58530	Bolt	4	4	4	4					4	4	4	4				
9*	804788	Pump mounting bracket	1	1	1	1					1	1	1	1				
10*	5804	Bolt	2	2	2	2					2	2	2	2				
11*	29437	Washer	2	2	2	2					2	2	2	2				
12*	804809	Adapter	1	1	1	1					1	1	1	1				
13	424282	Cooler, trans oil	1	1	1	1					1	1	1	1				
14*	425481	Filter	1	1	1	1					1	1	1	1				
15*	804808	Adapter	1	1	1	1					1	1	1	1				
16*	804819	O-ring	1	1	1	1					1	1	1	1				
17*	K217-8	Elbow	1	1	1	1					1	1	1	1				
18*	244242	Pump	1	1	1	1					1	1	1	1				
19*	54242	Nut	4	4	4	4					4	4	4	4				
20*	804804	Belt	1	1	1	1					1	1	1	1				
21*	244289	Pulley	1	1	1	1					1	1	1	1				
22*	804815	Hose assembly	1	1	1	1					1	1	1	1				
23*	804886	Hose assembly	1	1	1	1					1	1	1	1				
24*	K20386	Bolt	8	8	8	8					8	8	8	8				
25*	K34806	Washer	8	8	8	8					8	8	8	8				
26*	K33797	Nut	8	8	8	8					8	8	8	8				
27*	K44728	Washer	4	4	4	4					4	4	4	4				
28*	B104A4	Elbow	1	1	1	1					1	1	1	1				

* Items required to update 11CD30 to 11CD31.

11 CD 58

SENSORS, ENGINE (PERKINS) AND TRANSMISSION (4-SPEED, 2WD/4WD) SEE ALSO: 11 CC 14

M30-2	M30-4	M30-2 H	M30-4 H
M40-2	M40-4	M40-2 H	M40-4 H
M50-2	M50-4	M50-2 H	M50-4 H
M60-2	M60-4	M60-2 H	M60-4 H
M30-2 L	M30-4 L	M30-2 H L	M30-4 H L
M40-2 L	M40-4 L	M40-2 H L	M40-4 H L
M50-2 L	M50-4 L	M50-2 H L	M50-4 H L
M60-2 L	M60-4 L	M60-2 H L	M60-4 H L

NOTE: ENGINE COMPONENTS SHOWN ARE FOR PERKINS ENGINES ONLY (EXCEPT ITEMS 2 & 3). FOR CAT ENGINE COMPONENTS CONTACT YOUR NEAREST CATERPILLAR DEALER. FOR PERKINS COMPONENTS NOT FOUND IN THIS PARTS MANUAL CONTACT YOUR NEAREST PERKINS DEALER.

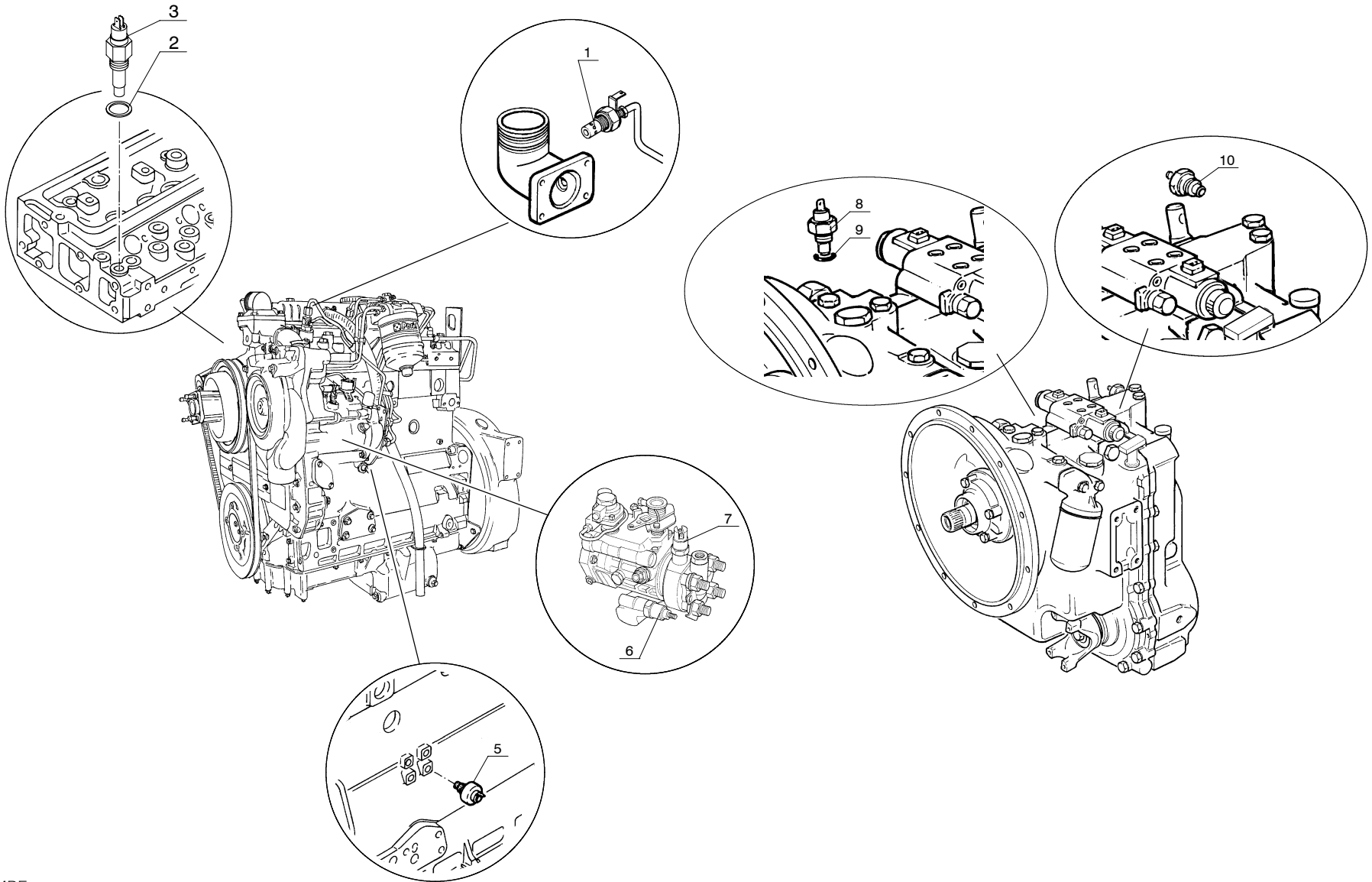

1	SENSORS, ENGINE (PERKINS) AND TRANSMISSION (4-SPEED, 2WD/4WD)			QUANTITY / MODEL										11 CD 58				
				M30-4	M40-4	M50-4	M60-4	M30-4 H	M40-4 H	M50-4 H	M60-4 H	M30-4 L	M40-4 L	M50-4 L	M60-4 L	M30-4 H L	M40-4 H L	M50-4 H L
ITEM	PART NO.	DESCRIPTION	M30-2	M40-2	M50-2	M60-2	M30-2 H	M40-2 H	M50-2 H	M60-2 H	M30-2 L	M40-2 L	M50-2 L	M60-2 L	M30-2 H L	M40-2 H L	M50-2 H L	M60-2 H L
1	563748	Heating plug	1	1	1	1					1	1	1	1				
2	5642	Copper seal (CAT OR PERKINS ENGINES)	1	1	1	1					1	1	1	1				
3	231199	Water temp sender (CAT OR PERKINS ENGINES)	1	1	1	1					1	1	1	1				
5	106389	Engine oil pressure sender	1	1	1	1					1	1	1	1				
6	561338	Starting electrovalve	1	1	1	1					1	1	1	1				
7	601673	Engine stop electrovalve	1	1	1	1					1	1	1	1				
8	552502	Oil temp sensor	1	1	1	1					1	1	1	1				
9	109657	O-ring	1	1	1	1					1	1	1	1				
10	549100	Transmission oil pressure switch	1	1	1	1					1	1	1	1				

12 AA 10

803121)G

DECALS
(SHEET 1 OF 2)

M30-2	M30-4	M30-2 H	M30-4 H
M40-2	M40-4	M40-2 H	M40-4 H
M50-2	M50-4	M50-2 H	M50-4 H
M60-2	M60-4	M60-2 H	M60-4 H
M30-2 L	M30-4 L	M30-2 H L	M30-4 H L
M40-2 L	M40-4 L	M40-2 H L	M40-4 H L
M50-2 L	M50-4 L	M50-2 H L	M50-4 H L
M60-2 L	M60-4 L	M60-2 H L	M60-4 H L

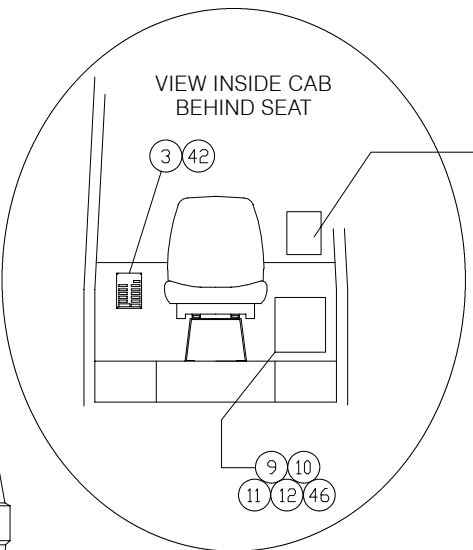
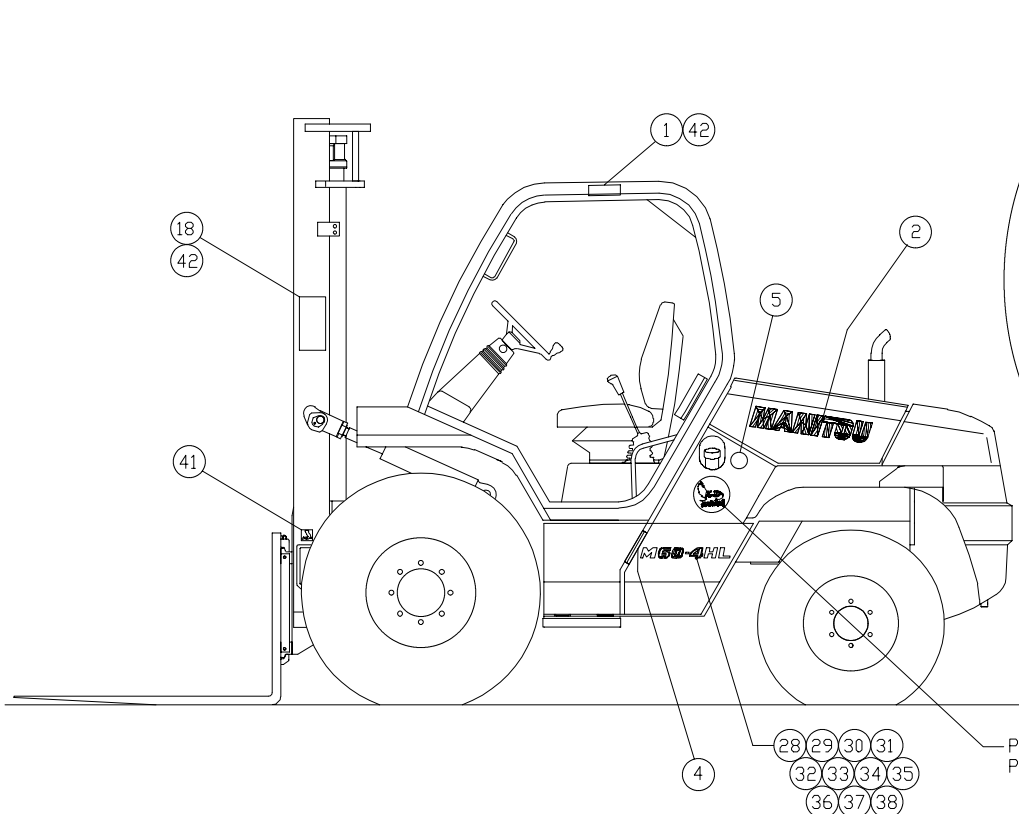

REFERENCE BREAKER DECAL LOCATION
PLACE NEAR BREAKER PANEL
804383 - CONSTRUCTION GRP.
804369 - POULTRY GRP. HYDROSTATIC
804382 - POULTRY GRP. TORQUE CONVERTER

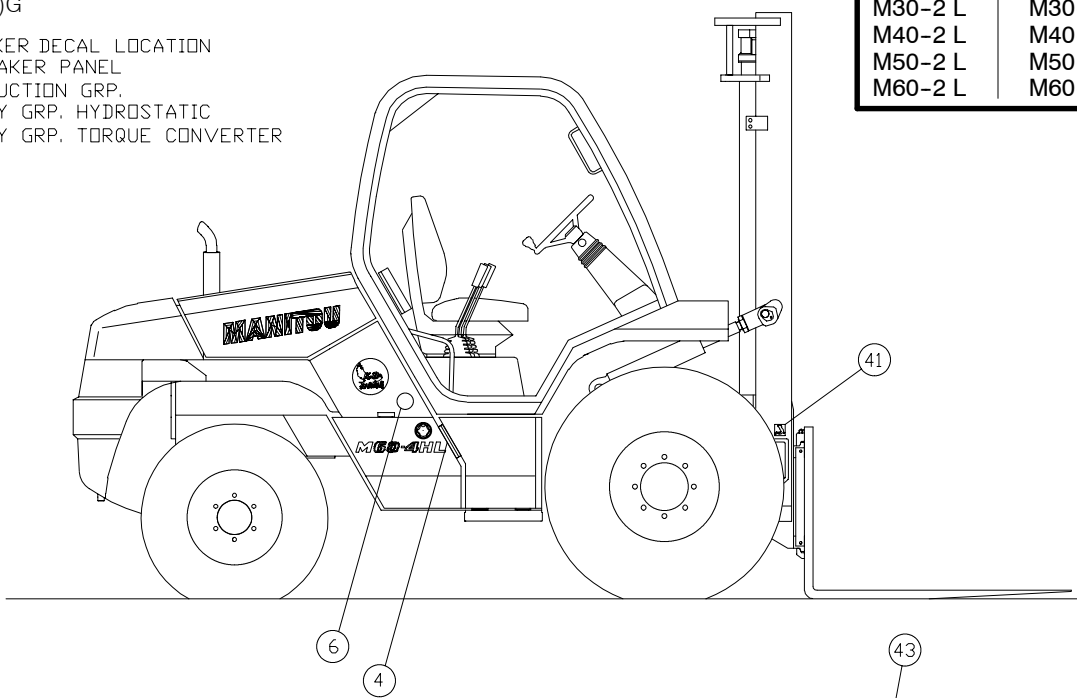

P/N: 803074
POULTRY

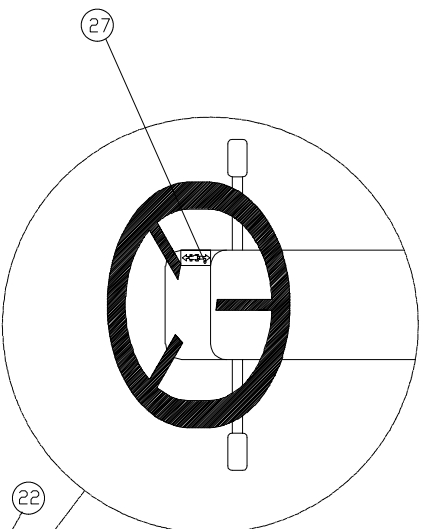

PLACE NEAR
HAND-BRAKE

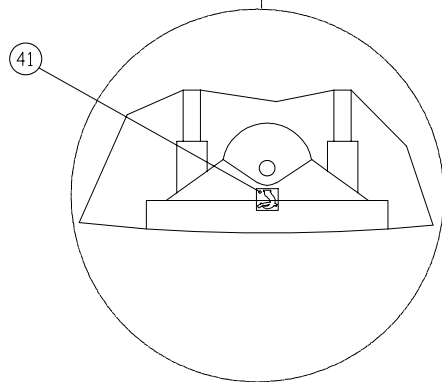
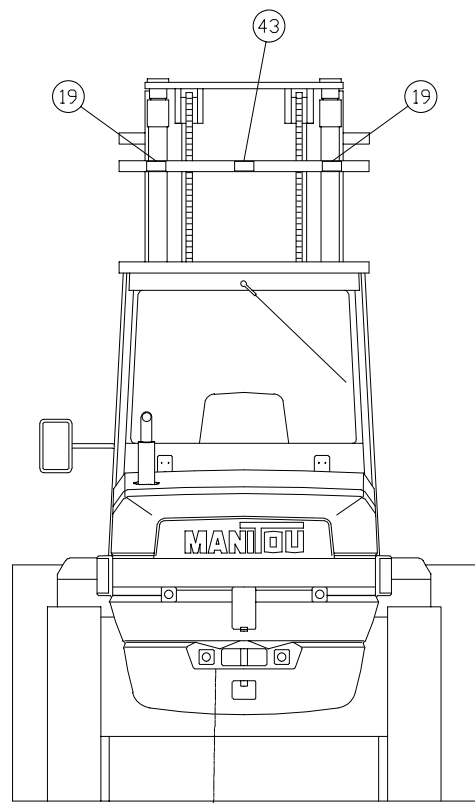
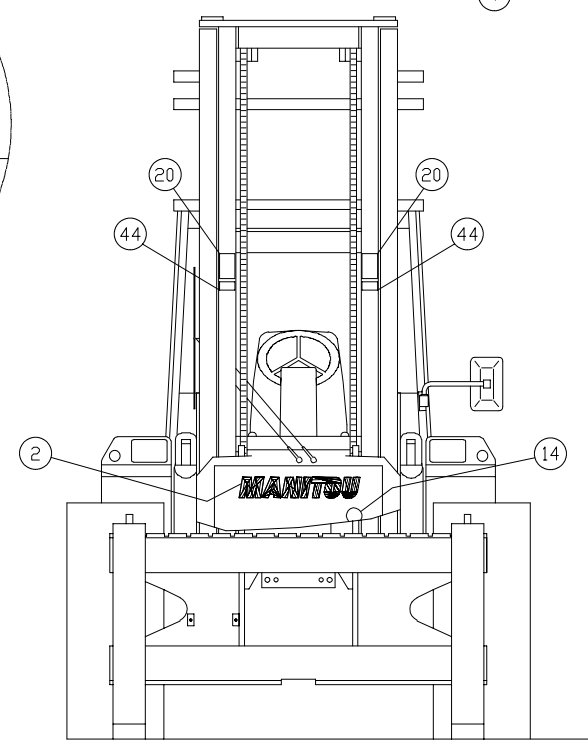
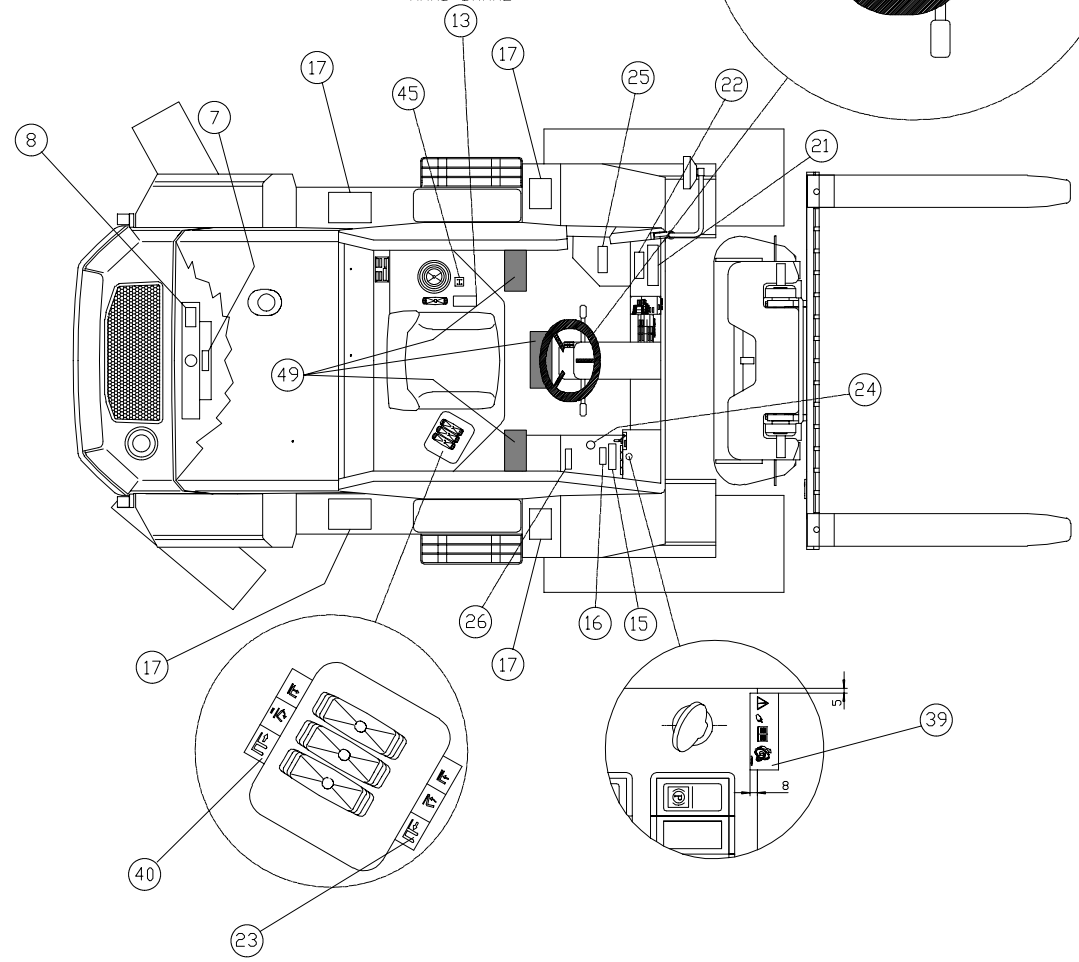

AP 2054

ENGINE, COMPLETE

M30-2	M30-4	M30-2 H	M30-4 H
M40-2	M40-4	M40-2 H	M40-4 H
M50-2	M50-4	M50-2 H	M50-4 H
M60-2	M60-4	M60-2 H	M60-4 H
M30-2 L	M30-4 L	M30-2 H L	M30-4 H L
M40-2 L	M40-4 L	M40-2 H L	M40-4 H L
M50-2 L	M50-4 L	M50-2 H L	M50-4 H L
M60-2 L	M60-4 L	M60-2 H L	M60-4 H L

NOTE: ENGINE COMPONENTS SHOWN ARE FOR PERKINS ENGINES - EXCEPT AS NOTED*.
 FOR COMPLETE CAT ENGINE SEE ITEM 1B ON THE FOLLOWING PAGE, FOR ALL OTHER ENGINE COMPONENTS CONTACT YOUR NEAREST CATERPILLAR DEALER
 FOR PERKINS COMPONENTS NOT FOUND IN THIS PARTS MANUAL CONTACT YOUR NEAREST PERKINS DEALER.

1ST MOUNTING S/N: 750284 & BELOW

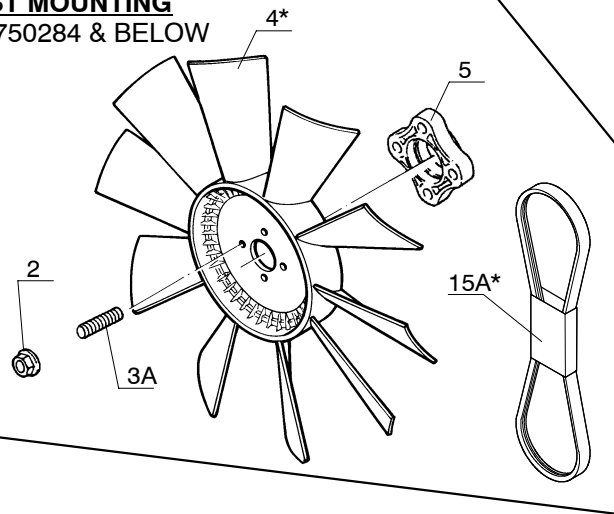

2ND MOUNTING S/N: 750285 & ABOVE

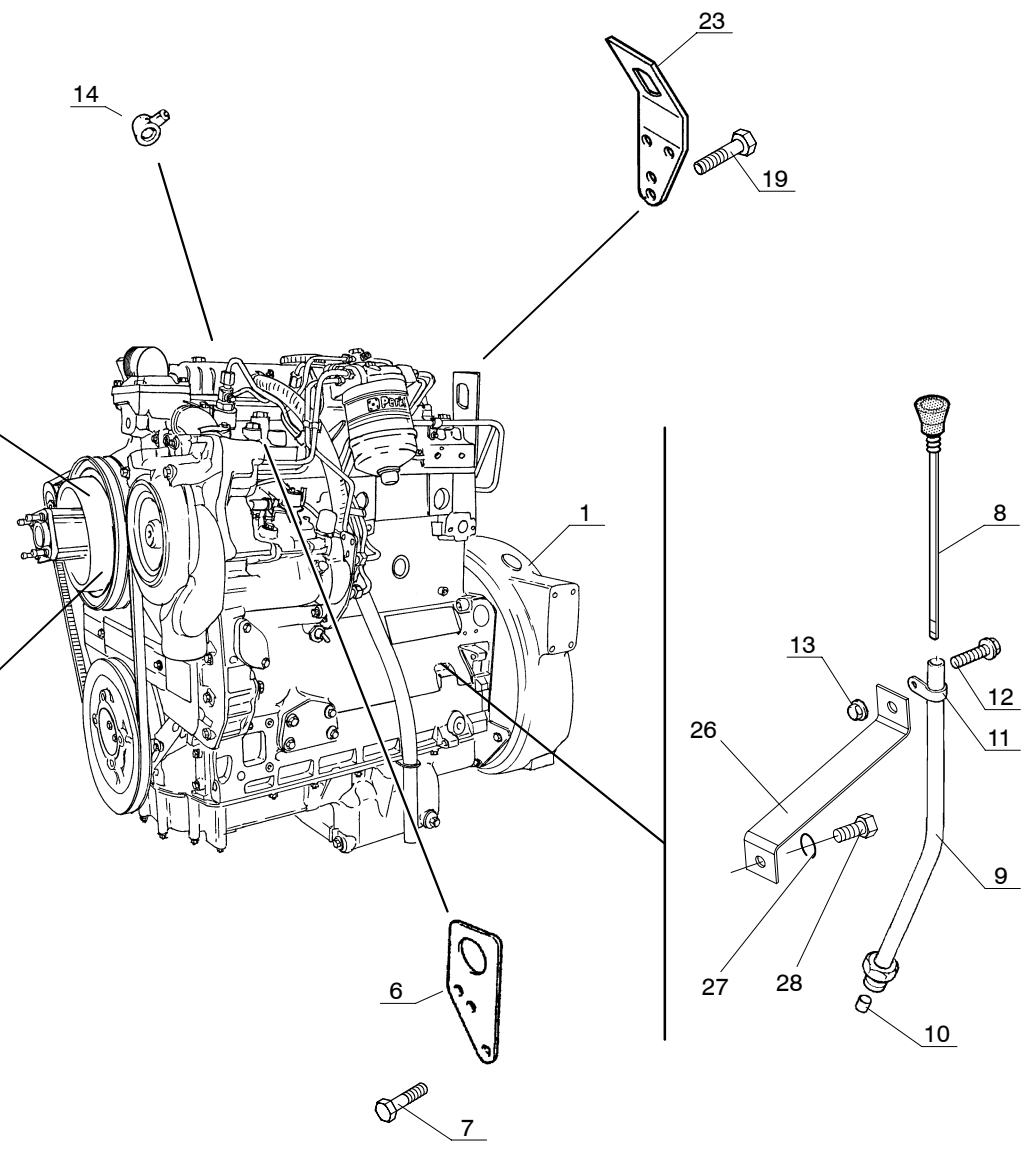
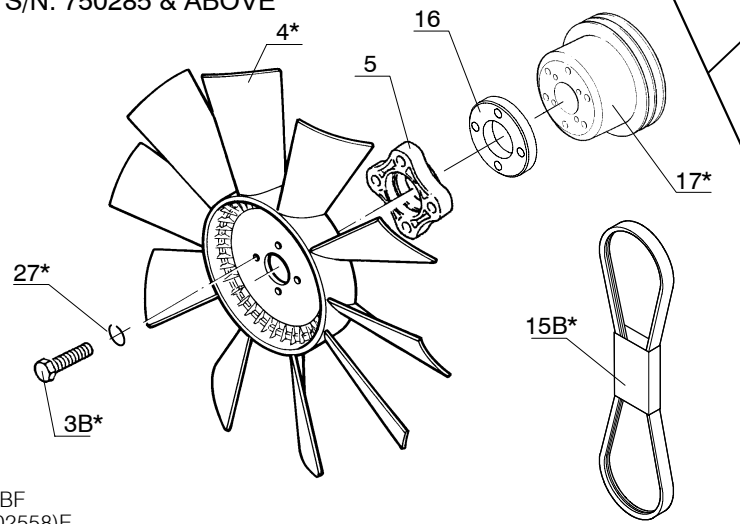

1	ENGINE, COMPLETE		QUANTITY / MODEL											AP 2054				
			M30-4	M40-4	M50-4	M60-4	M30-4 H	M40-4 H	M50-4 H	M60-4 H	M30-4 L	M40-4 L	M50-4 L	M60-4 L	M30-4 H L	M40-4 H L	M50-4 H L	M60-4 H L
ITEM	PART NO.	DESCRIPTION	M30-2	M40-2	M50-2	M60-2	M30-2 H	M40-2 H	M50-2 H	M60-2 H	M30-2 L	M40-2 L	M50-2 L	M60-2 L	M30-2 H L	M40-2 H L	M50-2 H L	M60-2 H L
1A	240897	Complete Engine, Perkins 1004-42 (AR81268)	1	1	1	1	1	1	1	1	1	1	1	1	1	1	1	1
1B	802557	Complete Engine, Caterpillar 207-1058	1	1	1	1	1	1	1	1	1	1	1	1	1	1	1	1
2	551662	Nut	4	4	4	4	4	4	4	4	4	4	4	4	4	4	4	4
3A	603479	Stud bolt	4	4	4	4	4	4	4	4	4	4	4	4	4	4	4	4
3B*	5322	Bolt	4	4	4	4	4	4	4	4	4	4	4	4	4	4	4	4
4*	494743	Blower fan	1	1	1	1	1	1	1	1	1	1	1	1	1	1	1	1
5	552640	Spacer	1	1	1	1	1	1	1	1	1	1	1	1	1	1	1	1
6	226430	Lug	1	1	1	1	1	1	1	1	1	1	1	1	1	1	1	1
7	473956	Screw	2	2	2	2	2	2	2	2	2	2	2	2	2	2	2	2
8	603208	Gauge	1	1	1	1	1	1	1	1	1	1	1	1	1	1	1	1
9	603205	Tube	1	1	1	1	1	1	1	1	1	1	1	1	1	1	1	1
10	474060	O-ring	1	1	1	1	1	1	1	1	1	1	1	1	1	1	1	1
11	551658	Clamp	1	1	1	1	1	1	1	1	1	1	1	1	1	1	1	1
12	107363	Screw	1	1	1	1	1	1	1	1	1	1	1	1	1	1	1	1
13	473939	Nut	1	1	1	1	1	1	1	1	1	1	1	1	1	1	1	1
14	170884	Cap	1	1	1	1	1	1	1	1	1	1	1	1	1	1	1	1
15A*	474948	Fan belt	1	1	1	1	1	1	1	1	1	1	1	1	1	1	1	1
15B*	496816	Fan belt	1	1	1	1	1	1	1	1	1	1	1	1	1	1	1	1
16	803974	Spacer	1	1	1	1	1	1	1	1	1	1	1	1	1	1	1	1
17*	552639	Pulley, fan	1	1	1	1	1	1	1	1	1	1	1	1	1	1	1	1
19	473956	Screw	2	2	2	2	2	2	2	2	2	2	2	2	2	2	2	2
23	230337	Fastening lug	1	1	1	1	1	1	1	1	1	1	1	1	1	1	1	1
26	802566	Bracket, oil dipstick	1	1	1	1	1	1	1	1	1	1	1	1	1	1	1	1
27*	42325	Washer, lock	5	5	5	5	5	5	5	5	5	5	5	5	5	5	5	5
28	42347	Bolt	1	1	1	1	1	1	1	1	1	1	1	1	1	1	1	1

* Used on Perkins and Cat engines.

AP 1430

STARTER MOTOR, PERKINS

M30-2	M30-4	M30-2 H	M30-4 H
M40-2	M40-4	M40-2 H	M40-4 H
M50-2	M50-4	M50-2 H	M50-4 H
M60-2	M60-4	M60-2 H	M60-4 H
M30-2 L	M30-4 L	M30-2 H L	M30-4 H L
M40-2 L	M40-4 L	M40-2 H L	M40-4 H L
M50-2 L	M50-4 L	M50-2 H L	M50-4 H L
M60-2 L	M60-4 L	M60-2 H L	M60-4 H L

NOTE: ENGINE COMPONENTS SHOWN ARE FOR PERKINS ENGINES ONLY.
 FOR CAT ENGINE COMPONENTS CONTACT YOUR NEAREST CATERPILLAR DEALER.
 FOR PERKINS COMPONENTS NOT FOUND IN THIS PARTS MANUAL CONTACT YOUR
 NEAREST PERKINS DEALER.

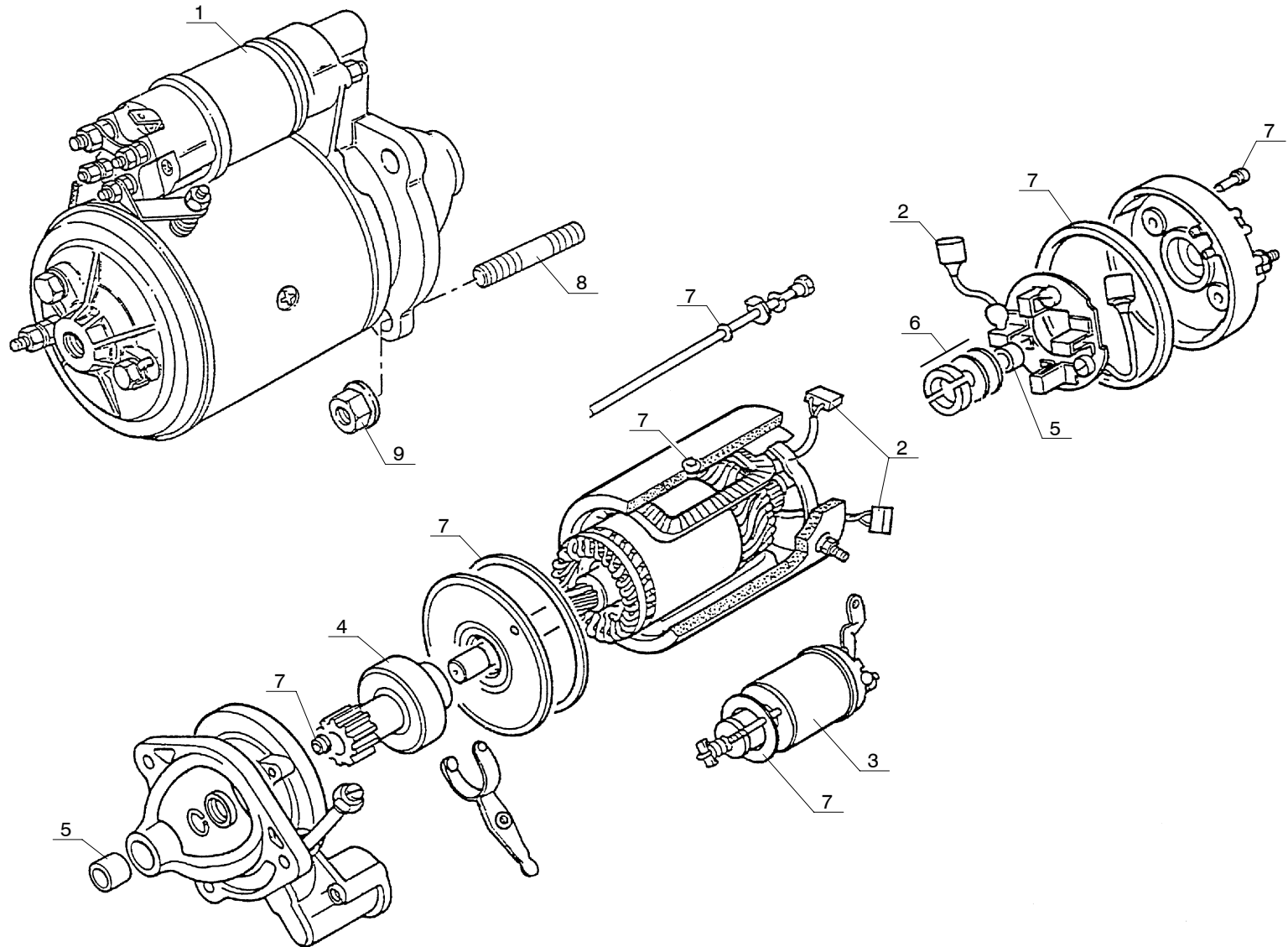

1	STARTER MOTOR, PERKINS												AP 1430						
	ITEM	PART NO.	DESCRIPTION	M30-2	M40-2	M50-2	M60-2	M30-2 H	M40-2 H	M50-2 H	M60-2 H	M30-2 L	M40-2 L	M50-2 L	M60-2 L	M30-2 H L	M40-2 H L	M50-2 H L	M60-2 H L
1	561414	Starter motor	1	1	1	1	1	1	1	1	1	1	1	1	1	1	1	1	1
2	473396	Brush kit	1	1	1	1	1	1	1	1	1	1	1	1	1	1	1	1	1
3	473401	Solenoid	1	1	1	1	1	1	1	1	1	1	1	1	1	1	1	1	1
4	561375	Pinion drive	1	1	1	1	1	1	1	1	1	1	1	1	1	1	1	1	1
5	473399	Bushing kit	1	1	1	1	1	1	1	1	1	1	1	1	1	1	1	1	1
6	473400	Lock washer	1	1	1	1	1	1	1	1	1	1	1	1	1	1	1	1	1
7	473404	Seal kit	1	1	1	1	1	1	1	1	1	1	1	1	1	1	1	1	1
8	473907	Stud bolt	3	3	3	3	3	3	3	3	3	3	3	3	3	3	3	3	3
9	473969	Nut	3	3	3	3	3	3	3	3	3	3	3	3	3	3	3	3	3

AP 1432

VALVE COVER AND BREATHER, PERKINS

NOTE: ENGINE COMPONENTS SHOWN ARE FOR PERKINS ENGINES ONLY.
FOR CAT ENGINE COMPONENTS CONTACT YOUR NEAREST CATERPILLAR DEALER.
FOR PERKINS COMPONENTS NOT FOUND IN THIS PARTS MANUAL CONTACT YOUR
NEAREST PERKINS DEALER.

M30-2	M30-4	M30-2 H	M30-4 H
M40-2	M40-4	M40-2 H	M40-4 H
M50-2	M50-4	M50-2 H	M50-4 H
M60-2	M60-4	M60-2 H	M60-4 H
M30-2 L	M30-4 L	M30-2 H L	M30-4 H L
M40-2 L	M40-4 L	M40-2 H L	M40-4 H L
M50-2 L	M50-4 L	M50-2 H L	M50-4 H L
M60-2 L	M60-4 L	M60-2 H L	M60-4 H L

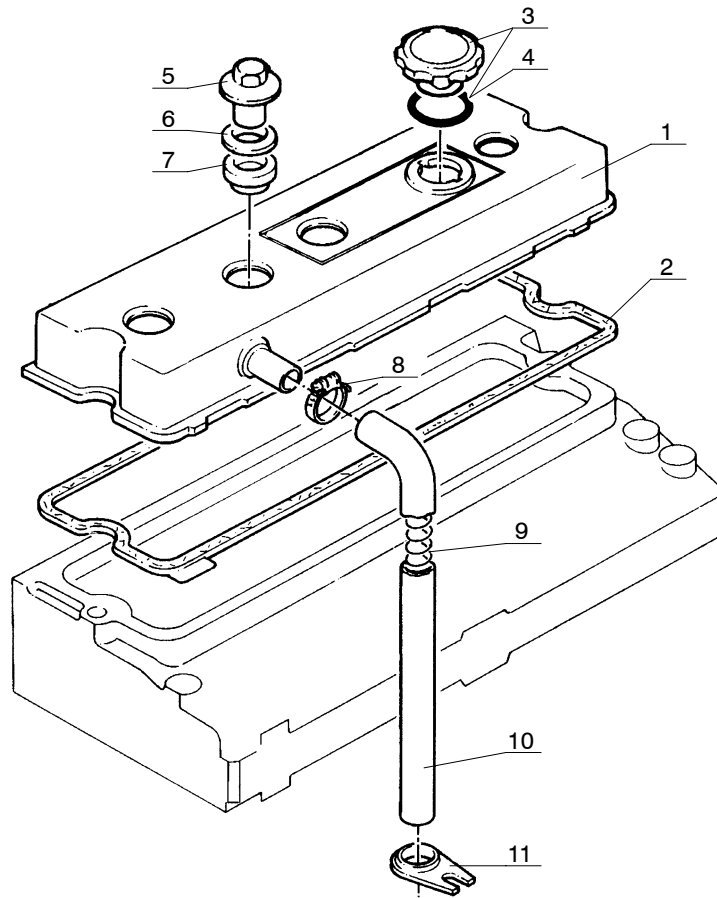

ITEM	PART NO.	DESCRIPTION	QUANTITY / MODEL												AP 1432			
			M30-2	M40-2	M50-2	M60-2	M30-2 H	M40-2 H	M50-2 H	M60-2 H	M30-2 L	M40-2 L	M50-2 L	M60-2 L	M30-4 H L	M40-4 H L	M50-4 H L	M60-4 H L
1		VALVE COVER AND BREATHER, PERKINS	M30-4	M40-4	M50-4	M60-4	M30-4 H	M40-4 H	M50-4 H	M60-4 H	M30-4 L	M40-4 L	M50-4 L	M60-4 L	M30-4 H L	M40-4 H L	M50-4 H L	M60-4 H L
1	604031	Cover	1	1	1	1	1	1	1	1	1	1	1	1	1	1	1	1
2	602877	Gasket	1	1	1	1	1	1	1	1	1	1	1	1	1	1	1	1
3	550493	Filling plug	1	1	1	1	1	1	1	1	1	1	1	1	1	1	1	1
4	603891	O-ring	1	1	1	1	1	1	1	1	1	1	1	1	1	1	1	1
5	478054	Nut	3	3	3	3	3	3	3	3	3	3	3	3	3	3	3	3
6	138165	Washer	3	3	3	3	3	3	3	3	3	3	3	3	3	3	3	3
7	550570	Seal	3	3	3	3	3	3	3	3	3	3	3	3	3	3	3	3
8	550499	Clamp	1	1	1	1	1	1	1	1	1	1	1	1	1	1	1	1
9	563506	Spring	1	1	1	1	1	1	1	1	1	1	1	1	1	1	1	1
10	603999	Pipe	1	1	1	1	1	1	1	1	1	1	1	1	1	1	1	1
11	474124	Bracket	1	1	1	1	1	1	1	1	1	1	1	1	1	1	1	1

AP 1434

OIL FILTER BRACKET, PERKINS

M30-2	M30-4	M30-2 H	M30-4 H
M40-2	M40-4	M40-2 H	M40-4 H
M50-2	M50-4	M50-2 H	M50-4 H
M60-2	M60-4	M60-2 H	M60-4 H
M30-2 L	M30-4 L	M30-2 H L	M30-4 H L
M40-2 L	M40-4 L	M40-2 H L	M40-4 H L
M50-2 L	M50-4 L	M50-2 H L	M50-4 H L
M60-2 L	M60-4 L	M60-2 H L	M60-4 H L

NOTE: ENGINE COMPONENTS SHOWN ARE FOR PERKINS ENGINES ONLY.
FOR CAT ENGINE COMPONENTS CONTACT YOUR NEAREST CATERPILLAR DEALER.
FOR PERKINS COMPONENTS NOT FOUND IN THIS PARTS MANUAL CONTACT YOUR NEAREST PERKINS DEALER.

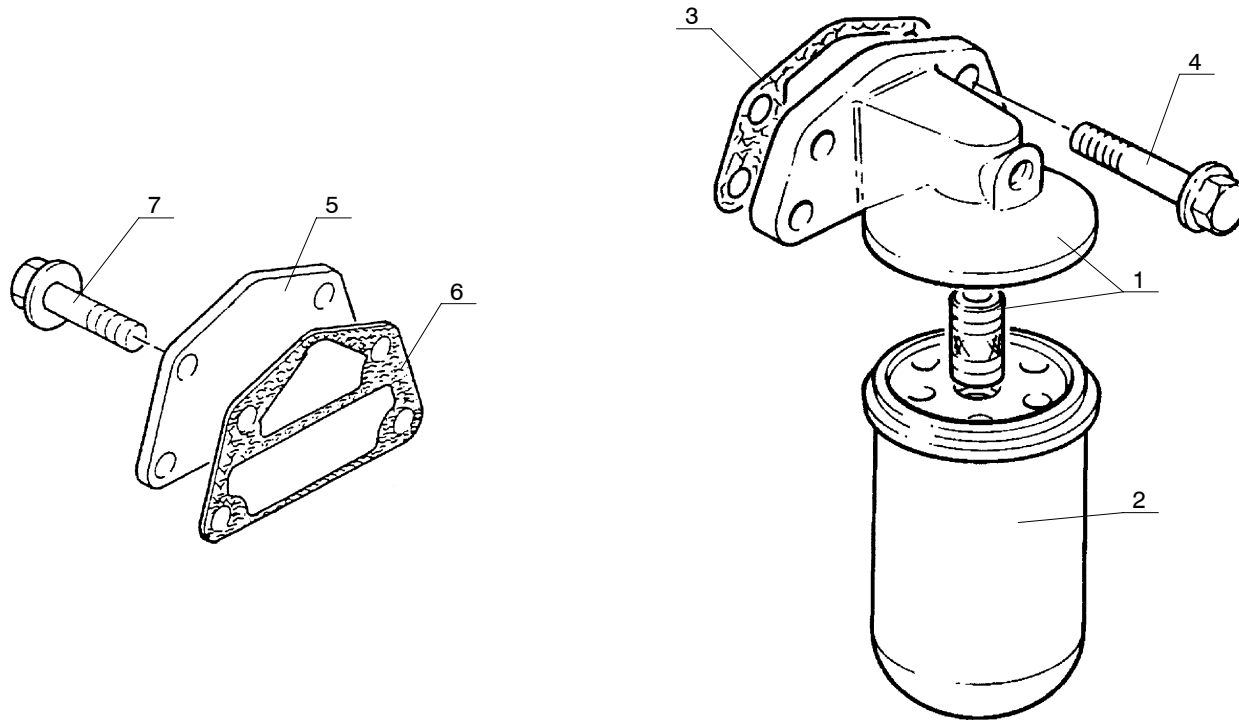

1	OIL FILTER BRACKET, PERKINS												AP 1434						
	ITEM	PART NO.	DESCRIPTION	M30-2	M40-2	M50-2	M60-2	M30-2 H	M40-2 H	M50-2 H	M60-2 H	M30-2 L	M40-2 L	M50-2 L	M60-2 L	M30-2 H L	M40-2 H L	M50-2 H L	M60-2 H L
1	474049	Filter head	1	1	1	1	1	1	1	1	1	1	1	1	1	1	1	1	1
2	133755	Oil filter, engine	1	1	1	1	1	1	1	1	1	1	1	1	1	1	1	1	1
3	475202	Gasket	1	1	1	1	1	1	1	1	1	1	1	1	1	1	1	1	1
4	474020	Screw	4	4	4	4	4	4	4	4	4	4	4	4	4	4	4	4	4
5	475205	Fastening plate	1	1	1	1	1	1	1	1	1	1	1	1	1	1	1	1	1
6	475202	Gasket	1	1	1	1	1	1	1	1	1	1	1	1	1	1	1	1	1
7	474054	Screw	4	4	4	4	4	4	4	4	4	4	4	4	4	4	4	4	4

AP 1435

WATER PUMP, PERKINS

M30-2	M30-4	M30-2 H	M30-4 H
M40-2	M40-4	M40-2 H	M40-4 H
M50-2	M50-4	M50-2 H	M50-4 H
M60-2	M60-4	M60-2 H	M60-4 H
M30-2 L	M30-4 L	M30-2 H L	M30-4 H L
M40-2 L	M40-4 L	M40-2 H L	M40-4 H L
M50-2 L	M50-4 L	M50-2 H L	M50-4 H L
M60-2 L	M60-4 L	M60-2 H L	M60-4 H L

NOTE: ENGINE COMPONENTS SHOWN ARE FOR PERKINS ENGINES ONLY.
 FOR CAT ENGINE COMPONENTS CONTACT YOUR NEAREST CATERPILLAR DEALER.
 FOR PERKINS COMPONENTS NOT FOUND IN THIS PARTS MANUAL CONTACT YOUR
 NEAREST PERKINS DEALER.

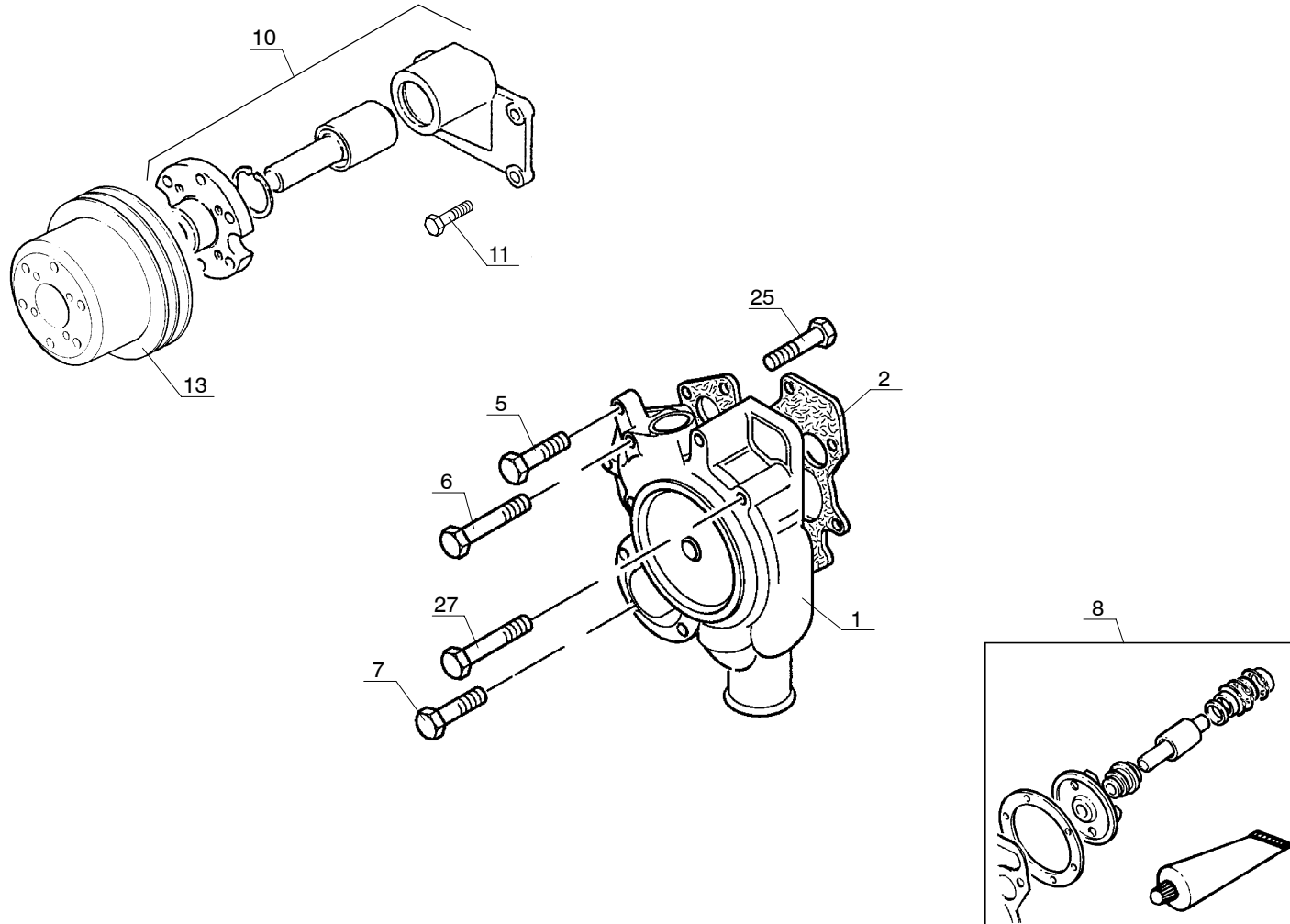

1	WATER PUMP, PERKINS												AP 1435						
	ITEM	PART NO.	DESCRIPTION	M30-2	M40-2	M50-2	M60-2	M30-2 H	M40-2 H	M50-2 H	M60-2 H	M30-2 L	M40-2 L	M50-2 L	M60-2 L	M30-2 H L	M40-2 H L	M50-2 H L	M60-2 H L
1	564646	Water pump	1	1	1	1	1	1	1	1	1	1	1	1	1	1	1	1	1
2	563295	Gasket	1	1	1	1	1	1	1	1	1	1	1	1	1	1	1	1	1
5	473816	Screw	1	1	1	1	1	1	1	1	1	1	1	1	1	1	1	1	1
6	474032	Screw	3	3	3	3	3	3	3	3	3	3	3	3	3	3	3	3	3
7	474005	Screw	3	3	3	3	3	3	3	3	3	3	3	3	3	3	3	3	3
8	601570	Repair kit	1	1	1	1	1	1	1	1	1	1	1	1	1	1	1	1	1
10	552413	Housing	1	1	1	1	1	1	1	1	1	1	1	1	1	1	1	1	1
11	474075	Screw	4	4	4	4	4	4	4	4	4	4	4	4	4	4	4	4	4
13	552412	Pulley	1	1	1	1	1	1	1	1	1	1	1	1	1	1	1	1	1
25	476074	Screw	2	2	2	2	2	2	2	2	2	2	2	2	2	2	2	2	2
27	475201	Screw	1	1	1	1	1	1	1	1	1	1	1	1	1	1	1	1	1

AP 1436

WATER OUTLET CONNECTIONS, PERKINS

NOTE: ENGINE COMPONENTS SHOWN ARE FOR PERKINS ENGINES ONLY.
 FOR CAT ENGINE COMPONENTS CONTACT YOUR NEAREST CATERPILLAR DEALER.
 FOR PERKINS COMPONENTS NOT FOUND IN THIS PARTS MANUAL CONTACT YOUR
 NEAREST PERKINS DEALER.

M30-2	M30-4	M30-2 H	M30-4 H
M40-2	M40-4	M40-2 H	M40-4 H
M50-2	M50-4	M50-2 H	M50-4 H
M60-2	M60-4	M60-2 H	M60-4 H
M30-2 L	M30-4 L	M30-2 H L	M30-4 H L
M40-2 L	M40-4 L	M40-2 H L	M40-4 H L
M50-2 L	M50-4 L	M50-2 H L	M50-4 H L
M60-2 L	M60-4 L	M60-2 H L	M60-4 H L

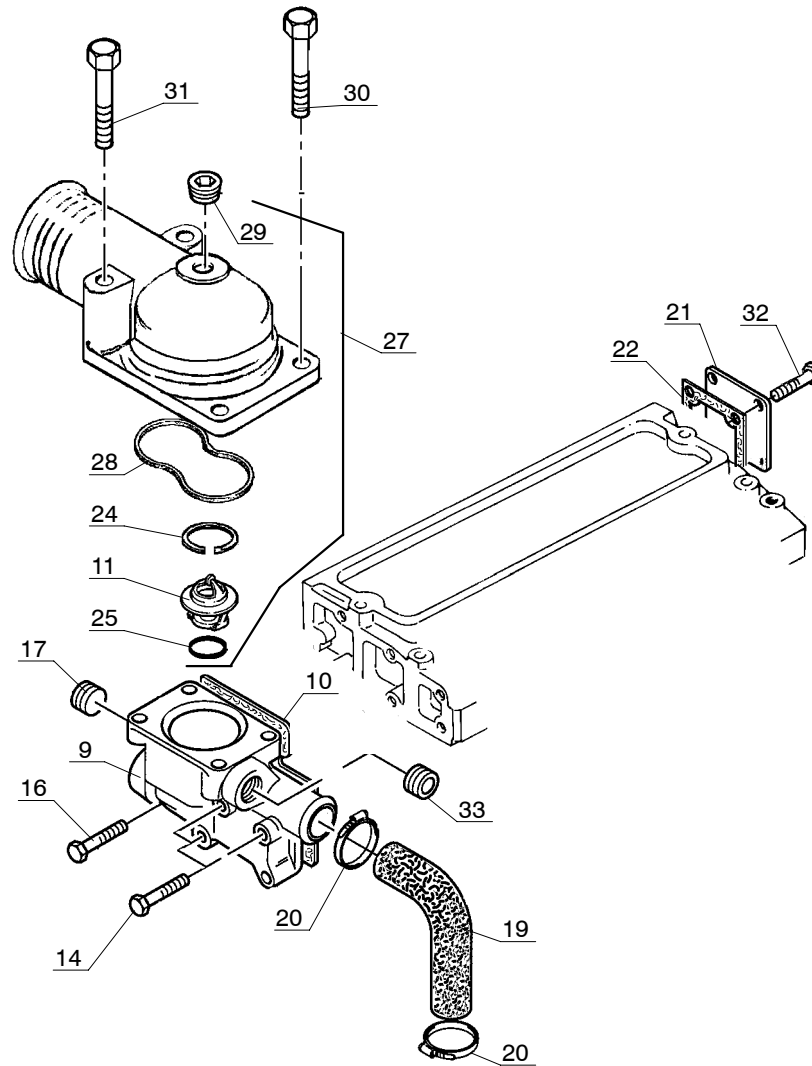

1	WATER OUTLET CONNECTIONS, PERKINS																		
	ITEM	PART NO.	DESCRIPTION	M30-2	M40-2	M50-2	M60-2	M30-2 H	M40-2 H	M50-2 H	M60-2 H	M30-2 L	M40-2 L	M50-2 L	M60-2 L	M30-2 H L	M40-2 H L	M50-2 H L	M60-2 H L
9	563289	Housing	1	1	1	1	1	1	1	1	1	1	1	1	1	1	1	1	1
10	563290	Gasket	1	1	1	1	1	1	1	1	1	1	1	1	1	1	1	1	1
11	563291	Thermostat	1	1	1	1	1	1	1	1	1	1	1	1	1	1	1	1	1
14	474031	Screw	3	3	3	3	3	3	3	3	3	3	3	3	3	3	3	3	3
16	476018	Screw	3	3	3	3	3	3	3	3	3	3	3	3	3	3	3	3	3
17	133739	Plug	1	1	1	1	1	1	1	1	1	1	1	1	1	1	1	1	1
19	563292	Hose + clamp	1	1	1	1	1	1	1	1	1	1	1	1	1	1	1	1	1
20	108236	Clamp	2	2	2	2	2	2	2	2	2	2	2	2	2	2	2	2	2
21	563287	Plate	1	1	1	1	1	1	1	1	1	1	1	1	1	1	1	1	1
22	563288	Gasket	1	1	1	1	1	1	1	1	1	1	1	1	1	1	1	1	1
24	564334	Circlips	1	1	1	1	1	1	1	1	1	1	1	1	1	1	1	1	1
25	563294	O-ring	1	1	1	1	1	1	1	1	1	1	1	1	1	1	1	1	1
27	564332	Connection	1	1	1	1	1	1	1	1	1	1	1	1	1	1	1	1	1
28	564333	O-ring	1	1	1	1	1	1	1	1	1	1	1	1	1	1	1	1	1
29	564341	Plug	1	1	1	1	1	1	1	1	1	1	1	1	1	1	1	1	1
30	473986	Screw	2	2	2	2	2	2	2	2	2	2	2	2	2	2	2	2	2
31	476018	Screw	2	2	2	2	2	2	2	2	2	2	2	2	2	2	2	2	2
32	474064	Screw	3	3	3	3	3	3	3	3	3	3	3	3	3	3	3	3	3
33	133739	Plug	1	1	1	1	1	1	1	1	1	1	1	1	1	1	1	1	1

AP 1437

ALTERNATOR INSTALLATION, PERKINS

NOTE: ENGINE COMPONENTS SHOWN ARE FOR PERKINS ENGINES ONLY.
 FOR CAT ENGINE COMPONENTS CONTACT YOUR NEAREST CATERPILLAR DEALER.
 FOR PERKINS COMPONENTS NOT FOUND IN THIS PARTS MANUAL CONTACT YOUR
 NEAREST PERKINS DEALER.

M30-2	M30-4	M30-2 H	M30-4 H
M40-2	M40-4	M40-2 H	M40-4 H
M50-2	M50-4	M50-2 H	M50-4 H
M60-2	M60-4	M60-2 H	M60-4 H
M30-2 L	M30-4 L	M30-2 H L	M30-4 H L
M40-2 L	M40-4 L	M40-2 H L	M40-4 H L
M50-2 L	M50-4 L	M50-2 H L	M50-4 H L
M60-2 L	M60-4 L	M60-2 H L	M60-4 H L

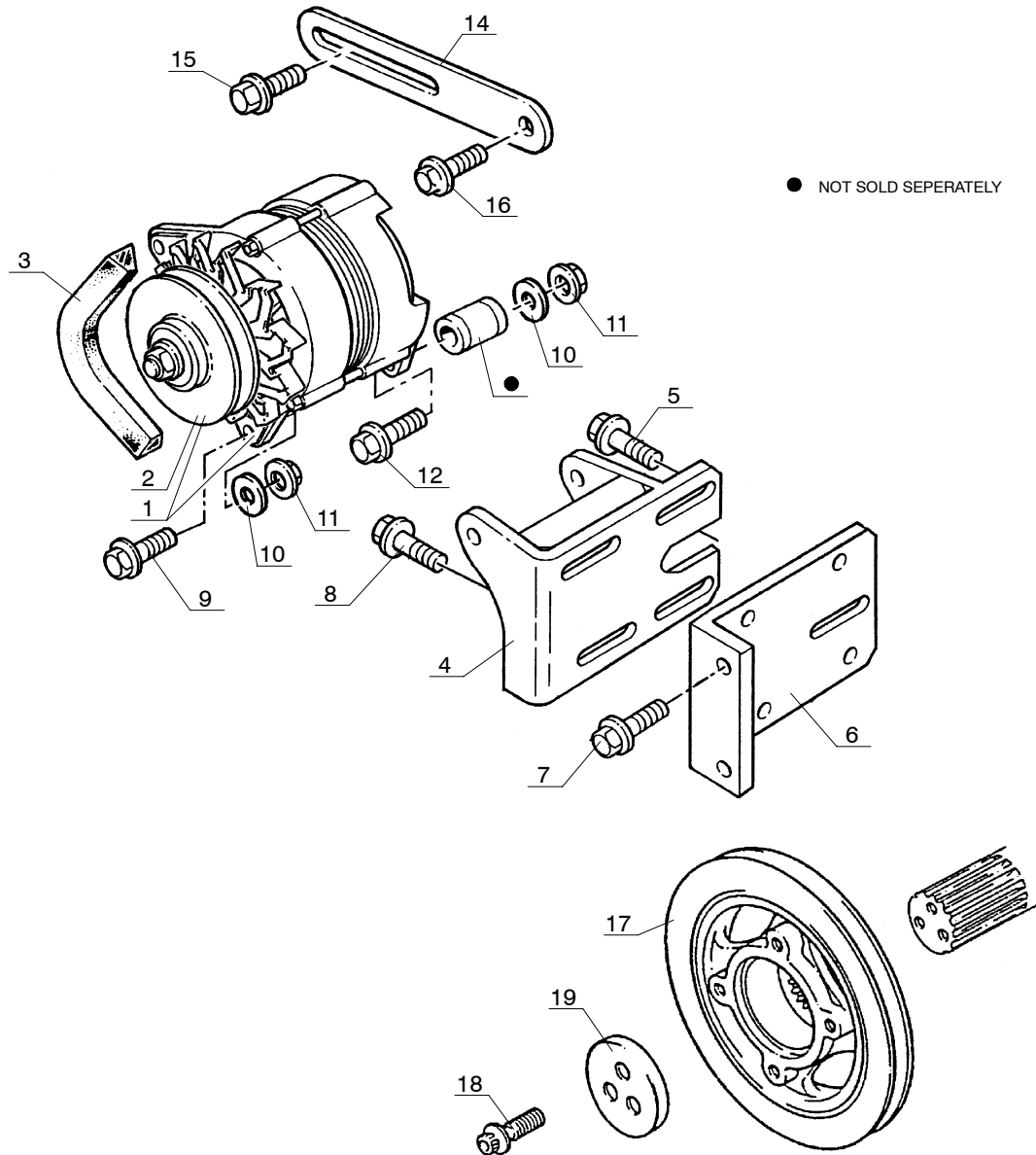

1	ALTERNATOR INSTALLATION, PERKINS												QUANTITY / MODEL				AP 1437			
	ITEM	PART NO.	DESCRIPTION	M30-2	M40-2	M50-2	M60-2	M30-2 H	M40-2 H	M50-2 H	M60-2 H	M30-2 L	M40-2 L	M50-2 L	M60-2 L	M30-2 H L	M40-2 H L	M50-2 H L	M60-2 H L	
1	563547	Alternator	1	1	1	1	1	1	1	1	1	1	1	1	1	1	1	1	1	
2	564961	Pulley	1	1	1	1	1	1	1	1	1	1	1	1	1	1	1	1	1	
3	474948	Belt	1	1	1	1	1	1	1	1	1	1	1	1	1	1	1	1	1	
4	563298	Bracket	1	1	1	1	1	1	1	1	1	1	1	1	1	1	1	1	1	
5	473956	Screw	1	1	1	1	1	1	1	1	1	1	1	1	1	1	1	1	1	
6	563299	Bracket	1	1	1	1	1	1	1	1	1	1	1	1	1	1	1	1	1	
7	474011	Screw	2	2	2	2	2	2	2	2	2	2	2	2	2	2	2	2	2	
8	474064	Screw	4	4	4	4	4	4	4	4	4	4	4	4	4	4	4	4	4	
9	473951	Screw	1	1	1	1	1	1	1	1	1	1	1	1	1	1	1	1	1	
10	109358	Washer	2	2	2	2	2	2	2	2	2	2	2	2	2	2	2	2	2	
11	551662	Nut	2	2	2	2	2	2	2	2	2	2	2	2	2	2	2	2	2	
12	474031	Screw	1	1	1	1	1	1	1	1	1	1	1	1	1	1	1	1	1	
14	563300	Lever	1	1	1	1	1	1	1	1	1	1	1	1	1	1	1	1	1	
15	107363	Screw	1	1	1	1	1	1	1	1	1	1	1	1	1	1	1	1	1	
16	563301	Screw	1	1	1	1	1	1	1	1	1	1	1	1	1	1	1	1	1	
17	474036	Pulley	1	1	1	1	1	1	1	1	1	1	1	1	1	1	1	1	1	
18	474038	Screw	3	3	3	3	3	3	3	3	3	3	3	3	3	3	3	3	3	
19	474037	Spacer	1	1	1	1	1	1	1	1	1	1	1	1	1	1	1	1	1	

TIER 2
PICTURE 1 of 3

ENGINE CONVERSION KIT, TO TIER 2

M30-2	M30-4	M30-2 H	M30-4 H
M40-2	M40-4	M40-2 H	M40-4 H
M50-2	M50-4	M50-2 H	M50-4 H
M60-2	M60-4	M60-2 H	M60-4 H
M30-2 L	M30-4 L	M30-2 H L	M30-4 H L
M40-2 L	M40-4 L	M40-2 H L	M40-4 H L
M50-2 L	M50-4 L	M50-2 H L	M50-4 H L
M60-2 L	M60-4 L	M60-2 H L	M60-4 H L

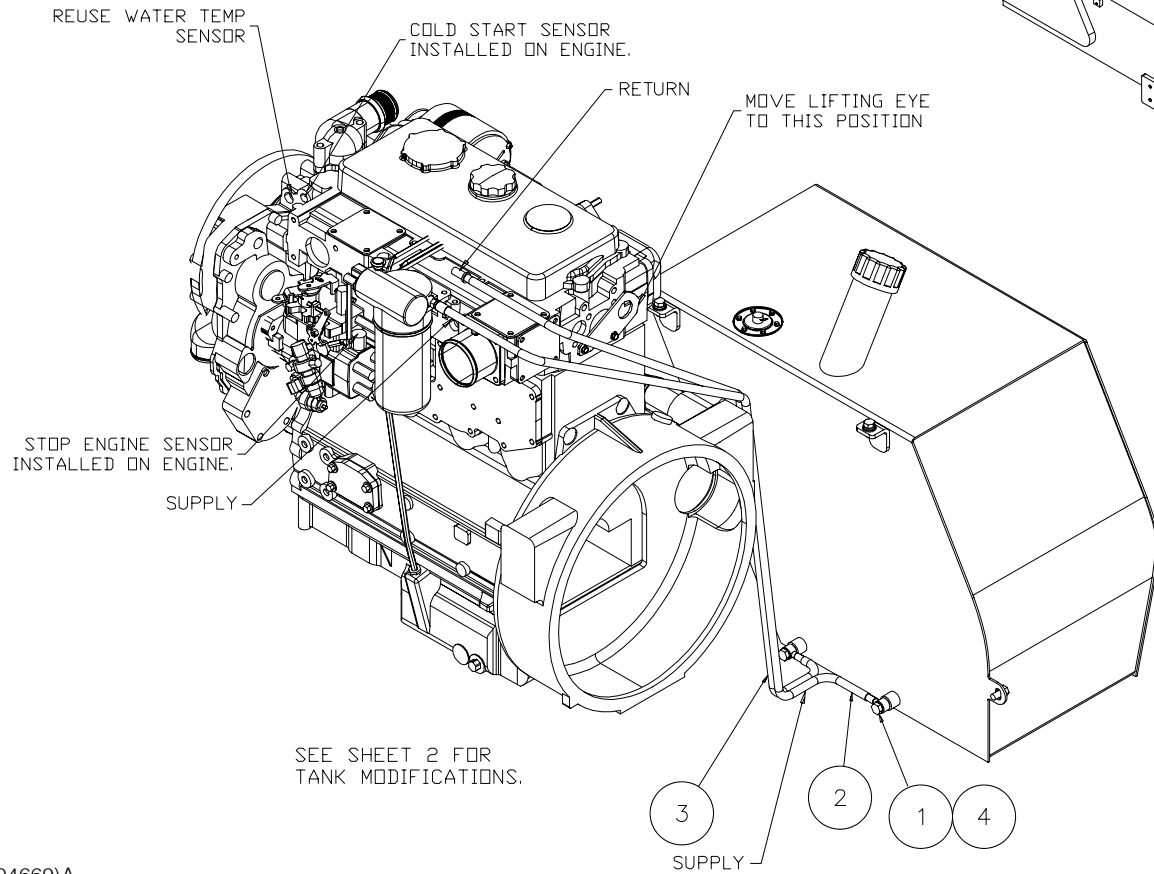
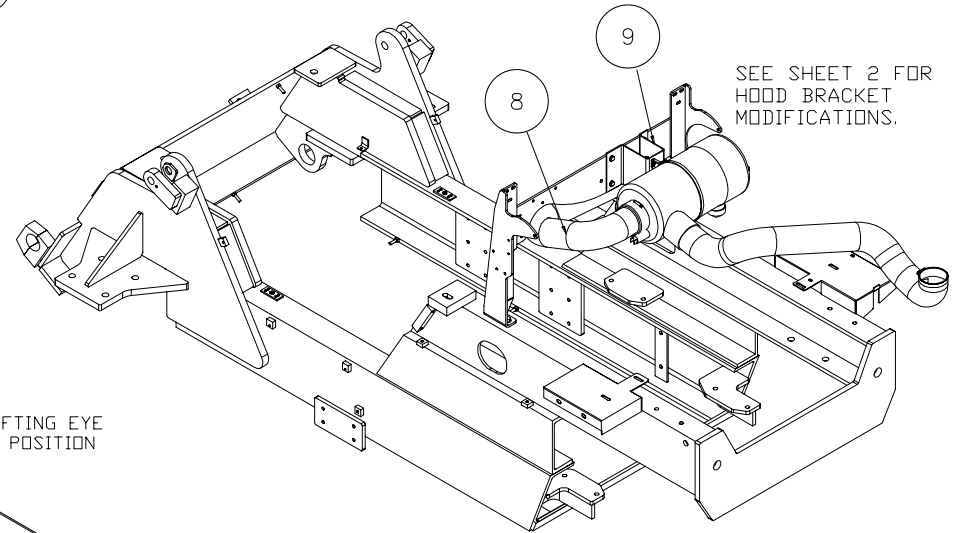
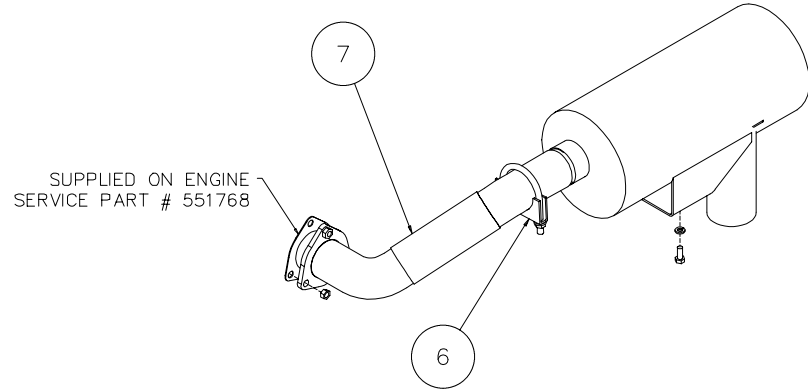

* NOTE: REMOVE 2" FAN SPACER FROM PERKINS ENGINE REPLACE WITH ITEM 20 1.5" FAN SPACER.

TIER 2
PICTURE 2 of 3

ENGINE CONVERSION KIT, TO TIER 2

M30-2	M30-4	M30-2 H	M30-4 H
M40-2	M40-4	M40-2 H	M40-4 H
M50-2	M50-4	M50-2 H	M50-4 H
M60-2	M60-4	M60-2 H	M60-4 H
M30-2 L	M30-4 L	M30-2 H L	M30-4 H L
M40-2 L	M40-4 L	M40-2 H L	M40-4 H L
M50-2 L	M50-4 L	M50-2 H L	M50-4 H L
M60-2 L	M60-4 L	M60-2 H L	M60-4 H L

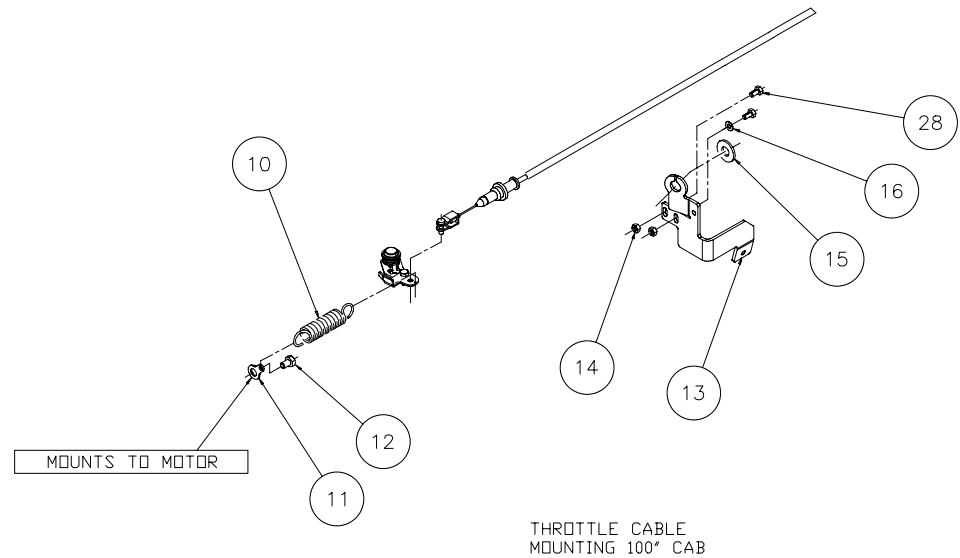
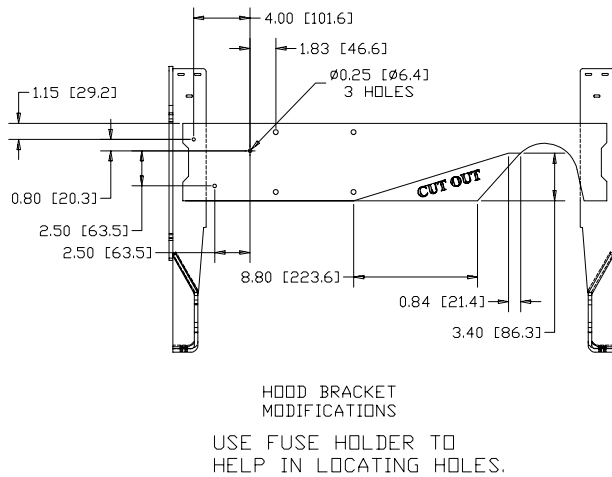
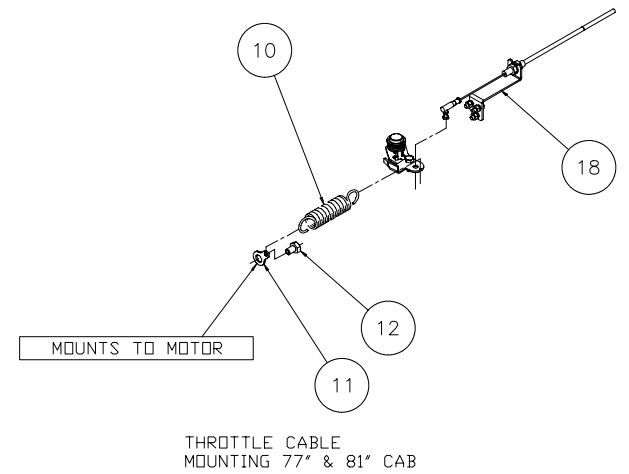
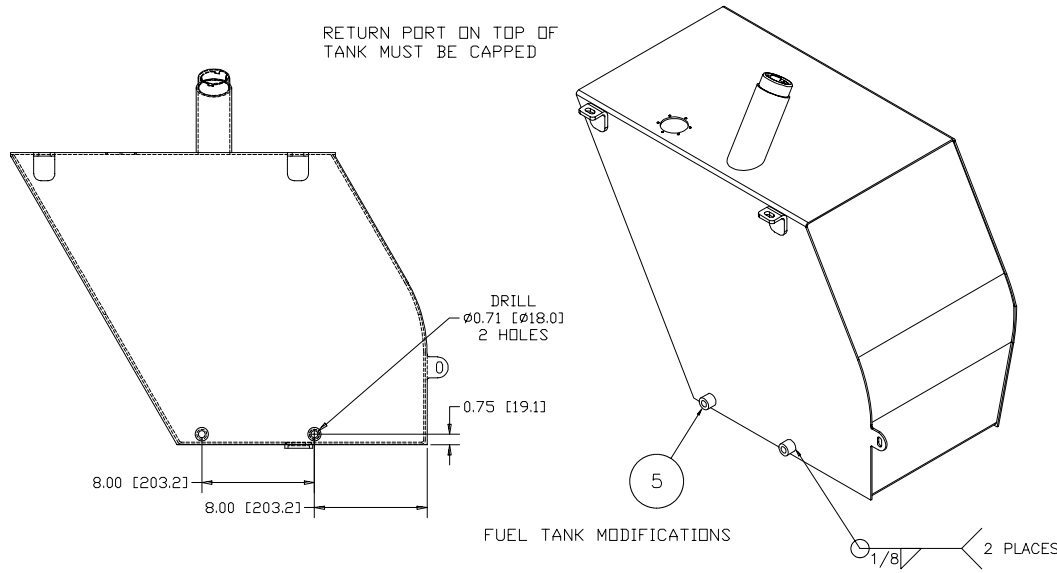

TIER 2
PICTURE 3 of 3

ENGINE CONVERSION KIT, TO TIER 2

M30-2	M30-4	M30-2 H	M30-4 H
M40-2	M40-4	M40-2 H	M40-4 H
M50-2	M50-4	M50-2 H	M50-4 H
M60-2	M60-4	M60-2 H	M60-4 H
M30-2 L	M30-4 L	M30-2 H L	M30-4 H L
M40-2 L	M40-4 L	M40-2 H L	M40-4 H L
M50-2 L	M50-4 L	M50-2 H L	M50-4 H L
M60-2 L	M60-4 L	M60-2 H L	M60-4 H L

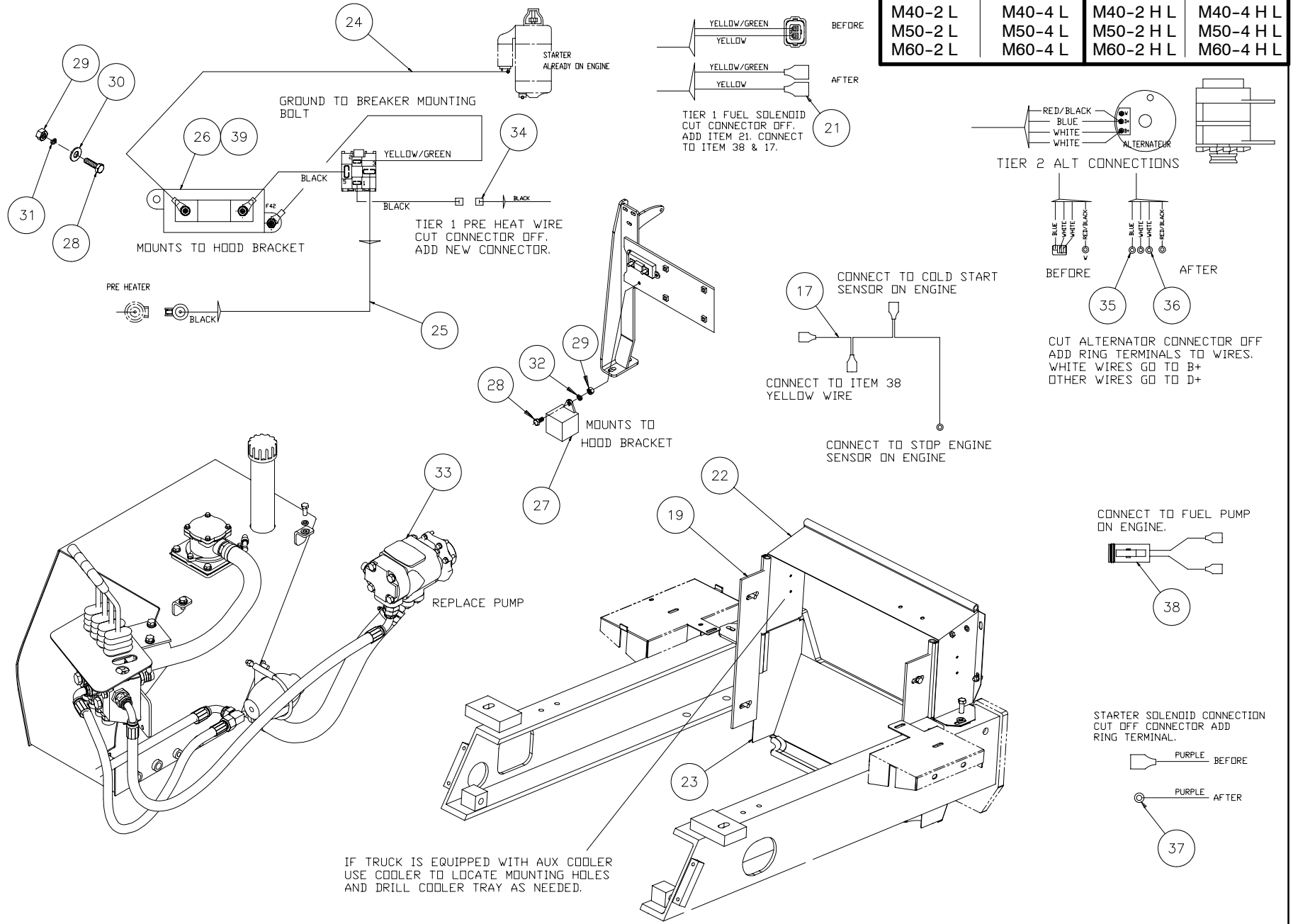

1	ENGINE CONVERSION KIT, TO TIER 2		QUANTITY / MODEL												TIER 2			
			M30-4	M40-4	M50-4	M60-4	M30-4 H	M40-4 H	M50-4 H	M60-4 H	M30-4 L	M40-4 L	M50-4 L	M60-4 L	M30-4 H L	M40-4 H L	M50-4 H L	M60-4 H L
ITEM	PART NO.	DESCRIPTION	M30-2	M40-2	M50-2	M60-2	M30-2 H	M40-2 H	M50-2 H	M60-2 H	M30-2 L	M40-2 L	M50-2 L	M60-2 L	M30-2 H L	M40-2 H L	M50-2 H L	M60-2 H L
	804676	Perkins Tier 2 Engine Kit, Conversion (Includes Item A and Items 1 thru 42)																
	804677	Caterpillar Tier 2 Engine Kit, Conversion (Includes Item B and Items 1 thru 39)																
A	247475	Perkins engine, Tier 2, 1104C-44																
B	804136	Caterpillar Engine, Tier 2, 207-1108																
C	804669	Conversion kit, less engine, includes Items 1 thru 39																
1	129397	Screw	2	2	2	2	2	2	2	2	2	2	2	2	2	2	2	2
2	247818	Hose assembly	1	1	1	1	1	1	1	1	1	1	1	1	1	1	1	1
3	247819	Hose assembly	1	1	1	1	1	1	1	1	1	1	1	1	1	1	1	1
4	3411	Seal	4	4	4	4	4	4	4	4	4	4	4	4	4	4	4	4
5	201849	Port	2	2	2	2	2	2	2	2	2	2	2	2	2	2	2	2
6	423625	Clamp	1	1	1	1	1	1	1	1	1	1	1	1	1	1	1	1
7	804374	Exhaust tube	1	1	1	1	1	1	1	1	1	1	1	1	1	1	1	1
8	247594	Hose	1	1	1	1	1	1	1	1	1	1	1	1	1	1	1	1
9	804500	Bracket, air filter	1	1	1	1	1	1	1	1	1	1	1	1	1	1	1	1
10	8081	Spring	1	1	1	1	1	1	1	1	1	1	1	1	1	1	1	1
11	204069	Plate, connection	1	1	1	1	1	1	1	1	1	1	1	1	1	1	1	1
12	31051	Bolt	1	1	1	1	1	1	1	1	1	1	1	1	1	1	1	1
13	247331	Bracket, accel cable	1	1	1	1	1	1	1	1	1	1	1	1	1	1	1	1
14	162229	Nut	2	2	2	2	2	2	2	2	2	2	2	2	2	2	2	2
15	61680	Washer	1	1	1	1	1	1	1	1	1	1	1	1	1	1	1	1
16	29469	Washer	2	2	2	2	2	2	2	2	2	2	2	2	2	2	2	2
17	804840	Wire assembly	1	1	1	1	1	1	1	1	1	1	1	1	1	1	1	1
18	804671	Bracket, accel cable	1	1	1	1	1	1	1	1	1	1	1	1	1	1	1	1
19	804572	Bracket, raditor	2	2	2	2	2	2	2	2	2	2	2	2	2	2	2	2
20	804373	Spacer, fan	1	1	1	1	1	1	1	1	1	1	1	1	1	1	1	1

AX 1225

GEARBOX, 2-SPEED REDUCTION

M30-2 H	M30-4 H
M40-2 H	M40-4 H
M50-2 H	M50-4 H
M60-2 H	M60-4 H
M30-2 H L	M30-4 H L
M40-2 H L	M40-4 H L
M50-2 H L	M50-4 H L
M60-2 H L	M60-4 H L

INSTALLATION LOCATION VARIES

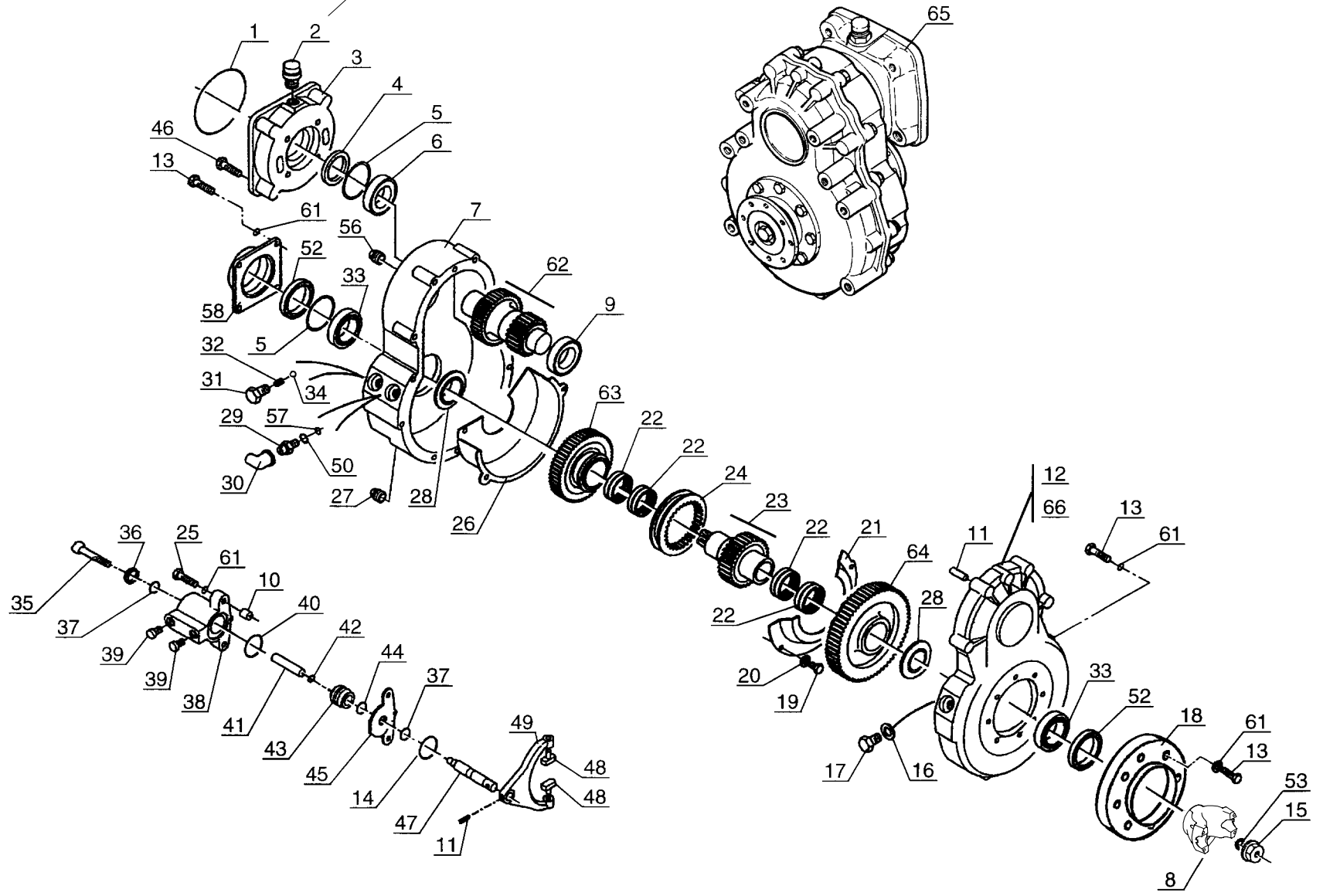

1	GEARBOX, 2-SPEED REDUCTION		QUANTITY / MODEL								AX 1225						
											M30-4 H	M40-4 H	M50-4 H	M60-4 H	M30-4 H L	M40-4 H L	M50-4 H L
ITEM	PART NO.	DESCRIPTION								M30-2 H	M40-2 H	M50-2 H	M60-2 H	M30-2 H L	M40-2 H L	M50-2 H L	M60-2 H L
1	564073	O-ring								1	1	1	1	1	1	1	1
2	552524	Air breather								1	1	1	1	1	1	1	1
3	564076	Cover								1	1	1	1	1	1	1	1
4	552509	Seal								1	1	1	1	1	1	1	1
5	133136	Shim .10mm (.004 in.)								A/R	A/R	A/R	A/R	A/R	A/R	A/R	A/R
5	133138	Shim .30mm (.012 in.)								A/R	A/R	A/R	A/R	A/R	A/R	A/R	A/R
5	478022	Shim .40mm (.016 in.)								A/R	A/R	A/R	A/R	A/R	A/R	A/R	A/R
5	552515	Shim .15mm (.006 in.)								A/R	A/R	A/R	A/R	A/R	A/R	A/R	A/R
5	562427	Shim .20mm (.008 in.)								A/R	A/R	A/R	A/R	A/R	A/R	A/R	A/R
6	105101	Bearing								1	1	1	1	1	1	1	1
7	563497	Housing								1	1	1	1	1	1	1	1
8	564248	Flange								2	2	2	2	2	2	2	2
9	105491	Bearing								1	1	1	1	1	1	1	1
10	564223	Bushing								2	2	2	2	2	2	2	2
11	552518	Centering pin								3	3	3	3	3	3	3	3
12	600593	Cover (Gearbox Serial No. Z. ITA. 739546 and below)								1	1	1	1	1	1	1	1
13	106842	Screw								24	24	24	24	24	24	24	24
14	475059	O-ring								1	1	1	1	1	1	1	1
15	562485	Nut								2	2	2	2	2	2	2	2
16	552514	Washer								1	1	1	1	1	1	1	1
17	552522	Screw								1	1	1	1	1	1	1	1
18	600595	Cover								1	1	1	1	1	1	1	1
19	105131	Screw								2	2	2	2	2	2	2	2
20	133118	Washer								2	2	2	2	2	2	2	2
21	552538	Protective housing								1	1	1	1	1	1	1	1
22	552513	Roller bearing								4	4	4	4	4	4	4	4
23	600596	Output shaft								1	1	1	1	1	1	1	1

2	GEARBOX, 2-SPEED REDUCTION		QUANTITY / MODEL								AX 1225			
											M30-4 H L	M40-4 H L	M50-4 H L	M60-4 H L
ITEM	PART NO.	DESCRIPTION	M30-2 H	M40-2 H	M50-2 H	M60-2 H					M30-2 H L	M40-2 H L	M50-2 H L	M60-2 H L
24A	601983	Change selector (GEARBOX 801992, 6K & 8K)	1	1							1	1		
24B	600597	Change selector (GEARBOX 226148, 10K & 12K)			1	1							1	1
25A	133177	Screw (GEARBOX 801992, 6K & 8K)	2	2							2	2		
25B	564224	Screw (GEARBOX 226148, 10K & 12K)			2	2							2	2
26	552537	Protective housing	1	1	1	1					1	1	1	1
27	133296	Magnetic plug	1	1	1	1					1	1	1	1
28	552531	Spacer	2	2	2	2					2	2	2	2
29	477475	Safety system switch	1	1	1	1					1	1	1	1
30	477476	Cap	1	1	1	1					1	1	1	1
31	564250	Screw	1	1	1	1					1	1	1	1
32	561947	Spring	1	1	1	1					1	1	1	1
33	133055	Bearing	2	2	2	2					2	2	2	2
34A	133131	Ball (GEARBOX 801992, 6K & 8K)	1	1							1	1		
34B	564221	Ball (GEARBOX 226148, 10K & 12K)			1	1							1	1
35	133187	Screw	1	1	1	1					1	1	1	1
36	552512	O-ring	1	1	1	1					1	1	1	1
37	563502	Seal	2	2	2	2					2	2	2	2
38	564245	Cylinder body	1	1	1	1					1	1	1	1
39	564226	Plug	2	2	2	2					2	2	2	2
40	564215	O-ring	1	1	1	1					1	1	1	1
41	564247	Cylinder rod	1	1	1	1					1	1	1	1
42	564216	O-ring	1	1	1	1					1	1	1	1
43	564246	Cylinder piston	1	1	1	1					1	1	1	1
44	564214	O-ring	1	1	1	1					1	1	1	1
45	563501	Protection plate	1	1	1	1					1	1	1	1
46	564074	Screw	4	4	4	4					4	4	4	4
47	564243	Rod	1	1	1	1					1	1	1	1

3	GEARBOX, 2-SPEED REDUCTION		QUANTITY / MODEL								AX 1225					
											M30-4 H L	M40-4 H L	M50-4 H L	M60-4 H L		
											M30-2 H L	M40-2 H L	M50-2 H L	M60-2 H L		
ITEM	PART NO.	DESCRIPTION														
48	552523	Slide block				2	2	2	2				2	2	2	2
49	552532	Fork				1	1	1	1				1	1	1	1
50	477474	Seal				1	1	1	1				1	1	1	1
52	552510	Seal				2	2	2	2				2	2	2	2
53	133027	O-ring				2	2	2	2				2	2	2	2
56	133276	Plug				1	1	1	1				1	1	1	1
57	477473	O-ring				1	1	1	1				1	1	1	1
58	552528	Cover				1	1	1	1				1	1	1	1
61	108556	Washer				22	22	22	22				22	22	22	22
62A	496430	Input shaft (GEARBOX 801992, 6K & 8K)				1	1						1	1		
62B	600598	Input shaft (GEARBOX 226148, 10K & 12K)							1	1					1	1
63A	564242	Gear (GEARBOX 801992, 6K & 8K)				1	1						1	1		
63B	600600	Gear (GEARBOX 226148, 10K & 12K)							1	1					1	1
64A	496431	Gear (GEARBOX 801992, 6K & 8K)				1	1						1	1		
64B	600599	Gear (GEARBOX 226148, 10K & 12K)							1	1					1	1
65A	801992	Complete reduction gearbox (6K & 8K)				1	1						1	1		
65B	226148	Complete reduction gearbox (10K & 12K)							1	1					1	1
66	600594	Cover (Gearbox Serial No. Z. ITA. 739547 and above)				1	1	1	1				1	1	1	1

AX 2519A

DRIVE AXLE, FRONT

M30-2	M30-4	M30-2 H	M30-4 H
M40-2	M40-4	M40-2 H	M40-4 H
M50-2	M50-4	M50-2 H	M50-4 H
M60-2	M60-4	M60-2 H	M60-4 H
M30-2 L	M30-4 L	M30-2 H L	M30-4 H L
M40-2 L	M40-4 L	M40-2 H L	M40-4 H L
M50-2 L	M50-4 L	M50-2 H L	M50-4 H L
M60-2 L	M60-4 L	M60-2 H L	M60-4 H L

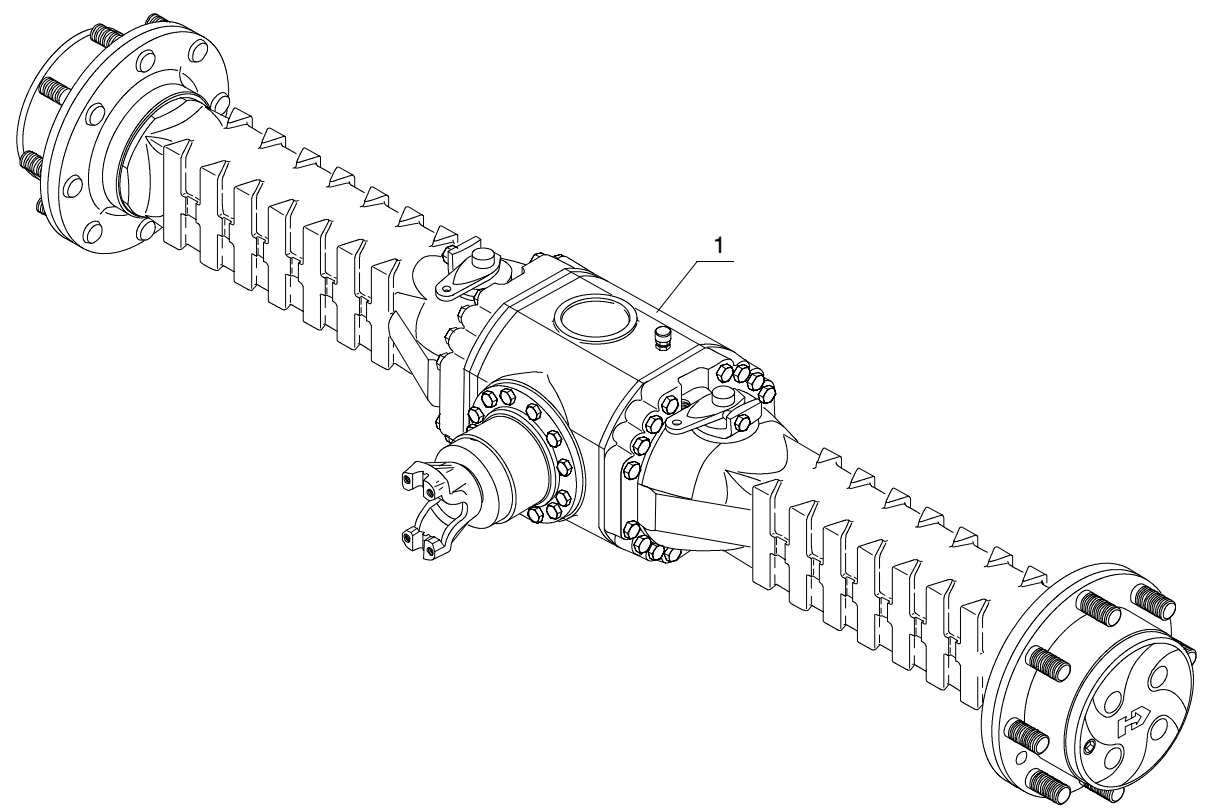

ITEM	PART NO.	DESCRIPTION	QUANTITY / MODEL												AX 2519A																				
			M30-2	M40-2	M50-2	M60-2	M30-2 H	M40-2 H	M50-2 H	M60-2 H	M30-2 L	M40-2 L	M50-2 L	M60-2 L	M30-4	M40-4	M50-4	M60-4	M30-4 H	M40-4 H	M50-4 H	M60-4 H													
1	801989	Drive axle, front	1	1	1	1	1	1	1	1	1	1	1	1	1	1	1	1	1	1	1	1	1	1	1	1	1	1	1	1	1	1	1	1	1

AX 1412

DRIVE AXLE, FRONT, CASING

M30-2	M30-4	M30-2 H	M30-4 H
M40-2	M40-4	M40-2 H	M40-4 H
M50-2	M50-4	M50-2 H	M50-4 H
M60-2	M60-4	M60-2 H	M60-4 H
M30-2 L	M30-4 L	M30-2 H L	M30-4 H L
M40-2 L	M40-4 L	M40-2 H L	M40-4 H L
M50-2 L	M50-4 L	M50-2 H L	M50-4 H L
M60-2 L	M60-4 L	M60-2 H L	M60-4 H L

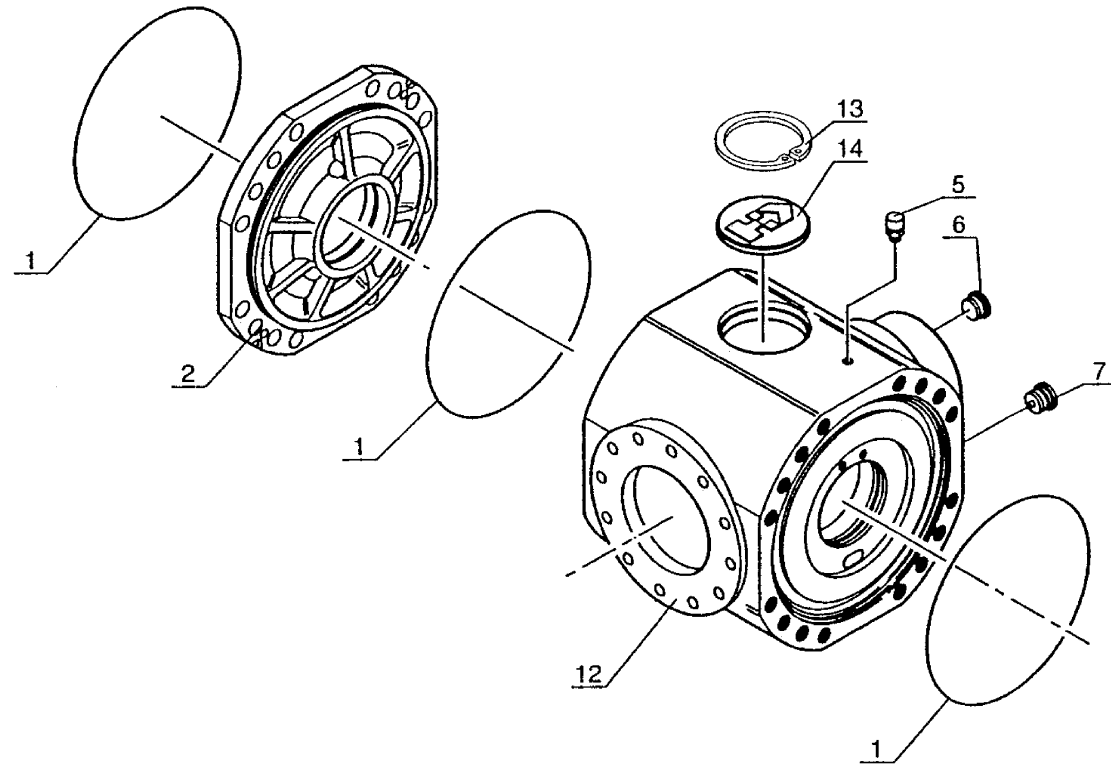

1	DRIVE AXLE, FRONT, CASING													QUANTITY / MODEL				AX 1412			
	ITEM	PART NO.	DESCRIPTION	M30-2	M40-2	M50-2	M60-2	M30-2 H	M40-2 H	M50-2 H	M60-2 H	M30-2 L	M40-2 L	M50-2 L	M60-2 L	M30-2 H L	M40-2 H L	M50-2 H L	M60-2 H L		
1	106533	O-ring	3	3	3	3	3	3	3	3	3	3	3	3	3	3	3	3	3		
2	562531	Housing	1	1	1	1	1	1	1	1	1	1	1	1	1	1	1	1	1		
5	562470	Air breather	1	1	1	1	1	1	1	1	1	1	1	1	1	1	1	1	1		
6	603638	Plug	1	1	1	1	1	1	1	1	1	1	1	1	1	1	1	1	1		
7	603639	Magnetic plug	1	1	1	1	1	1	1	1	1	1	1	1	1	1	1	1	1		
12	496425	Central casing	1	1	1	1	1	1	1	1	1	1	1	1	1	1	1	1	1		
13	133044	Circlip	1	1	1	1	1	1	1	1	1	1	1	1	1	1	1	1	1		
14	602293	Plug	1	1	1	1	1	1	1	1	1	1	1	1	1	1	1	1	1		

AX 1449

DRIVE AXLE, FRONT, DIFFERENTIAL

M30-2	M30-4	M30-2 H	M30-4 H
M40-2	M40-4	M40-2 H	M40-4 H
M50-2	M50-4	M50-2 H	M50-4 H
M60-2	M60-4	M60-2 H	M60-4 H
M30-2 L	M30-4 L	M30-2 H L	M30-4 H L
M40-2 L	M40-4 L	M40-2 H L	M40-4 H L
M50-2 L	M50-4 L	M50-2 H L	M50-4 H L
M60-2 L	M60-4 L	M60-2 H L	M60-4 H L

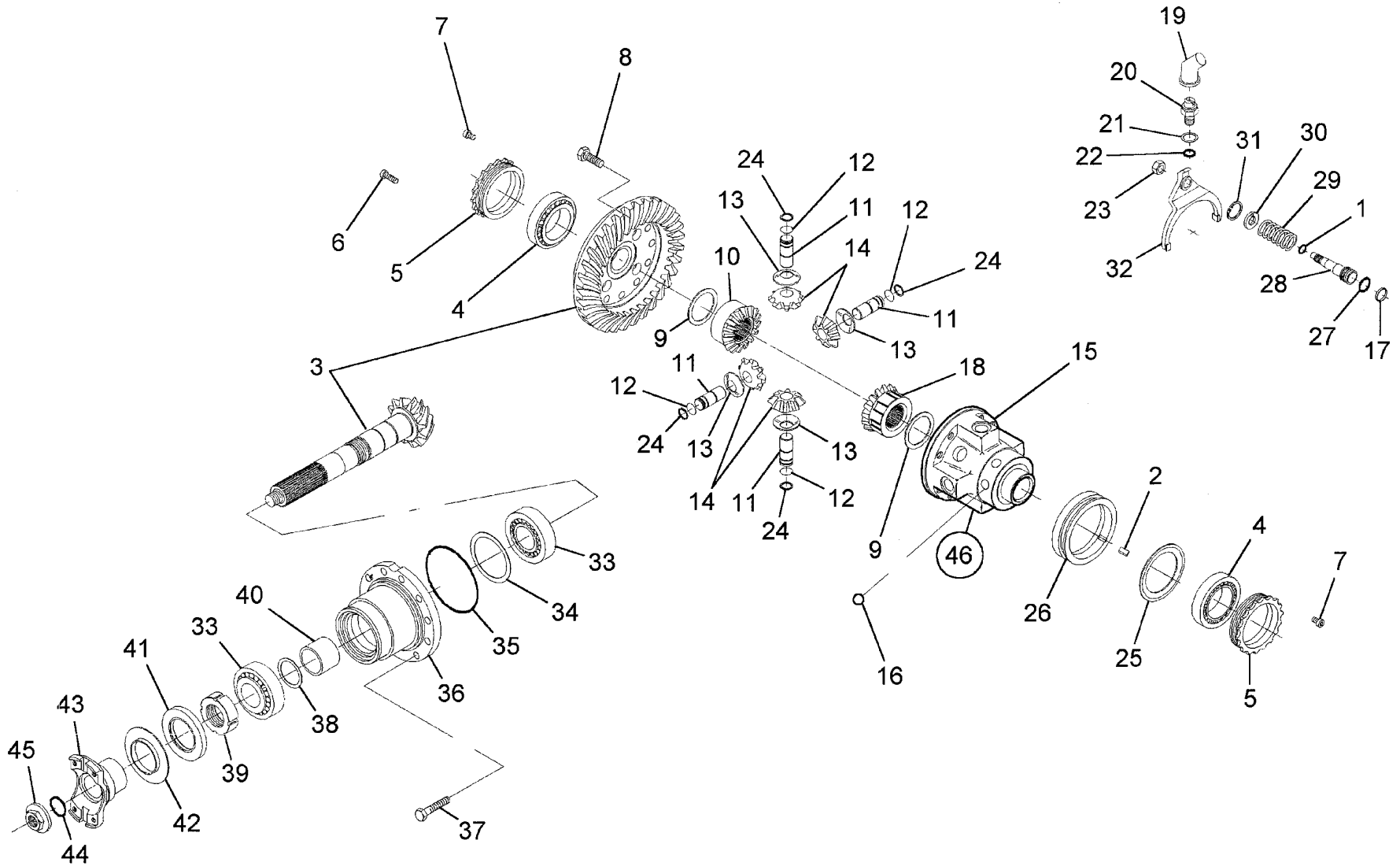

1	DRIVE AXLE, FRONT, DIFFERENTIAL		QUANTITY / MODEL											AX 1449				
			M30-4	M40-4	M50-4	M60-4	M30-4 H	M40-4 H	M50-4 H	M60-4 H	M30-4 L	M40-4 L	M50-4 L	M60-4 L	M30-4 H L	M40-4 H L	M50-4 H L	M60-4 H L
ITEM	PART NO.	DESCRIPTION	M30-2	M40-2	M50-2	M60-2	M30-2 H	M40-2 H	M50-2 H	M60-2 H	M30-2 L	M40-2 L	M50-2 L	M60-2 L	M30-2 H L	M40-2 H L	M50-2 H L	M60-2 H L
1	601945	Circlip	1	1	1	1	1	1	1	1	1	1	1	1	1	1	1	1
2	601935	Key	1	1	1	1	1	1	1	1	1	1	1	1	1	1	1	1
3	601558	Bevel gear set	1	1	1	1	1	1	1	1	1	1	1	1	1	1	1	1
4	106550	Tapered roller bearing	2	2	2	2	2	2	2	2	2	2	2	2	2	2	2	2
5	562474	Ring nut	2	2	2	2	2	2	2	2	2	2	2	2	2	2	2	2
6	133186	Bolt	4	4	4	4	4	4	4	4	4	4	4	4	4	4	4	4
7	109912	Bolt	2	2	2	2	2	2	2	2	2	2	2	2	2	2	2	2
8	601243	Bolt	12	12	12	12	12	12	12	12	12	12	12	12	12	12	12	12
9	562476	Washer	2	2	2	2	2	2	2	2	2	2	2	2	2	2	2	2
10	562477	Differential side gear	2	2	2	2	2	2	2	2	2	2	2	2	2	2	2	2
11	562478	Pin	4	4	4	4	4	4	4	4	4	4	4	4	4	4	4	4
12	562479	Circlips	4	4	4	4	4	4	4	4	4	4	4	4	4	4	4	4
13	562480	Washer	4	4	4	4	4	4	4	4	4	4	4	4	4	4	4	4
14	562481	Differential pinion	4	4	4	4	4	4	4	4	4	4	4	4	4	4	4	4
15	603310	Differential carrier	1	1	1	1	1	1	1	1	1	1	1	1	1	1	1	1
16	601941	Detend ball	6	6	6	6	6	6	6	6	6	6	6	6	6	6	6	6
17	601943	Ring	1	1	1	1	1	1	1	1	1	1	1	1	1	1	1	1
18	601937	Differential side gear	1	1	1	1	1	1	1	1	1	1	1	1	1	1	1	1
19	603311	Boot	1	1	1	1	1	1	1	1	1	1	1	1	1	1	1	1
20	603303	Security switch	1	1	1	1	1	1	1	1	1	1	1	1	1	1	1	1
21	496426	Washer, lock	1	1	1	1	1	1	1	1	1	1	1	1	1	1	1	1
22	477473	O-ring	1	1	1	1	1	1	1	1	1	1	1	1	1	1	1	1
23	601949	Nut	1	1	1	1	1	1	1	1	1	1	1	1	1	1	1	1
24	562486	Circlips	4	4	4	4	4	4	4	4	4	4	4	4	4	4	4	4
25	603312	Sheet	1	1	1	1	1	1	1	1	1	1	1	1	1	1	1	1
26	601998	Selector	1	1	1	1	1	1	1	1	1	1	1	1	1	1	1	1
27	477693	O-ring	1	1	1	1	1	1	1	1	1	1	1	1	1	1	1	1
28	601944	Piston	1	1	1	1	1	1	1	1	1	1	1	1	1	1	1	1

AX 1450

DRIVE AXLE, FRONT, REDUCTION GEAR

M30-2	M30-4	M30-2 H	M30-4 H
M40-2	M40-4	M40-2 H	M40-4 H
M50-2	M50-4	M50-2 H	M50-4 H
M60-2	M60-4	M60-2 H	M60-4 H
M30-2 L	M30-4 L	M30-2 H L	M30-4 H L
M40-2 L	M40-4 L	M40-2 H L	M40-4 H L
M50-2 L	M50-4 L	M50-2 H L	M50-4 H L
M60-2 L	M60-4 L	M60-2 H L	M60-4 H L

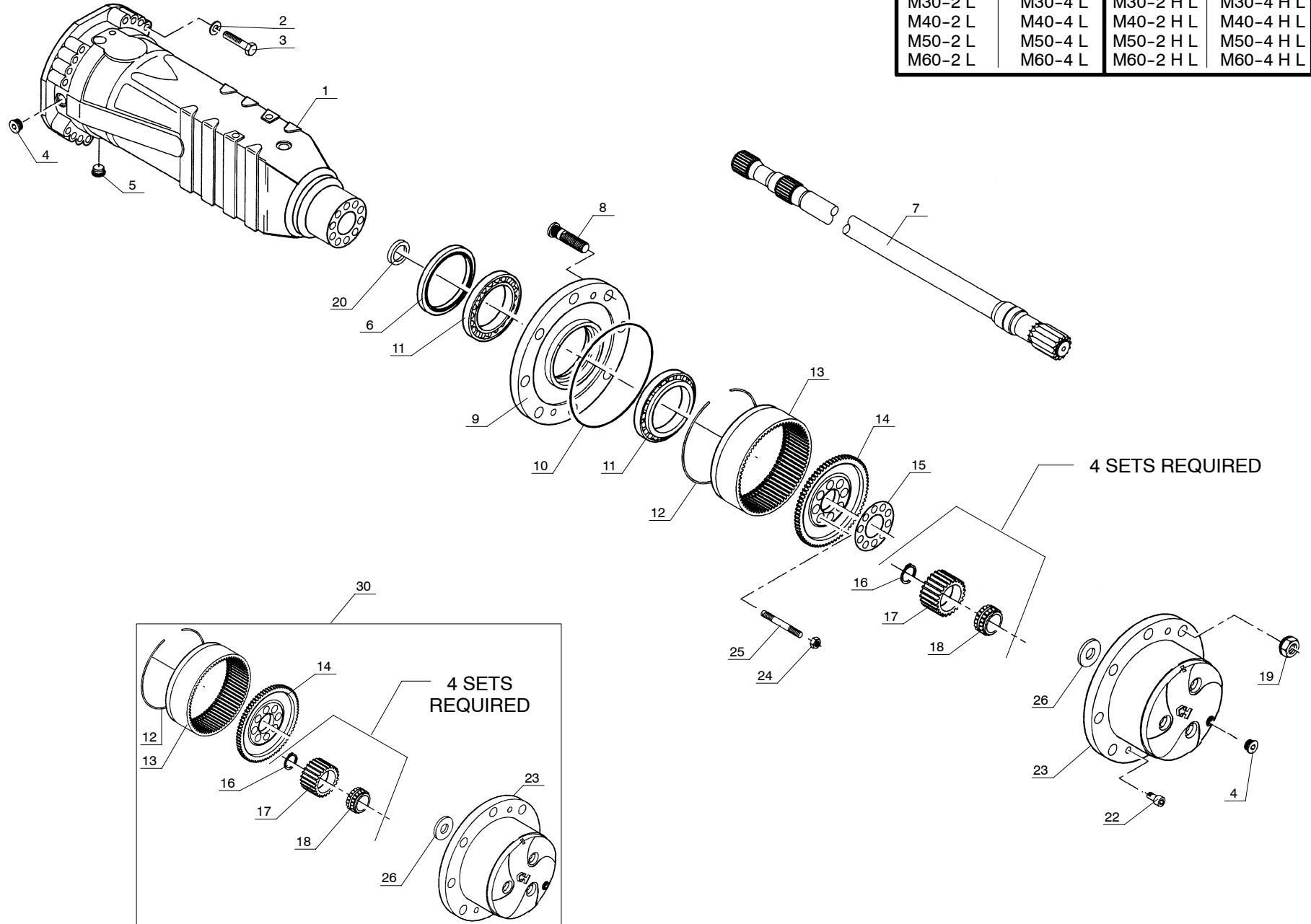

1	DRIVE AXLE, FRONT, REDUCTION GEAR		QUANTITY / MODEL											AX 1450				
			M30-4	M40-4	M50-4	M60-4	M30-4 H	M40-4 H	M50-4 H	M60-4 H	M30-4 L	M40-4 L	M50-4 L	M60-4 L	M30-4 H L	M40-4 H L	M50-4 H L	M60-4 H L
ITEM	PART NO.	DESCRIPTION	M30-2	M40-2	M50-2	M60-2	M30-2 H	M40-2 H	M50-2 H	M60-2 H	M30-2 L	M40-2 L	M50-2 L	M60-2 L	M30-2 H L	M40-2 H L	M50-2 H L	M60-2 H L
1	602787	Lateral axel case	2	2	2	2	2	2	2	2	2	2	2	2	2	2	2	2
2	562490	Washer	32	32	32	32	32	32	32	32	32	32	32	32	32	32	32	32
3	702138	Bolt	32	32	32	32	32	32	32	32	32	32	32	32	32	32	32	32
4	603638	Plug	4	4	4	4	4	4	4	4	4	4	4	4	4	4	4	4
5	603639	Magnetic plug	2	2	2	2	2	2	2	2	2	2	2	2	2	2	2	2
6	604656	Seal	2	2	2	2	2	2	2	2	2	2	2	2	2	2	2	2
7	602788	Drive shaft	2	2	2	2	2	2	2	2	2	2	2	2	2	2	2	2
8	106080	Wheel stud	16	16	16	16	16	16	16	16	16	16	16	16	16	16	16	16
9	601246	Wheel hub	2	2	2	2	2	2	2	2	2	2	2	2	2	2	2	2
10	106533	O-ring	2	2	2	2	2	2	2	2	2	2	2	2	2	2	2	2
11	562504	Bearing	4	4	4	4	4	4	4	4	4	4	4	4	4	4	4	4
12	562514	Circlips	2	2	2	2	2	2	2	2	2	2	2	2	2	2	2	2
13	564133	Gear ring	2	2	2	2	2	2	2	2	2	2	2	2	2	2	2	2
14	565998	Ring gear bracket	2	2	2	2	2	2	2	2	2	2	2	2	2	2	2	2
15	562515	Locking plate	2	2	2	2	2	2	2	2	2	2	2	2	2	2	2	2
16	562508	Circlips	8	8	8	8	8	8	8	8	8	8	8	8	8	8	8	8
17	562509	Planet wheel	8	8	8	8	8	8	8	8	8	8	8	8	8	8	8	8
18	562510	Bearing	8	8	8	8	8	8	8	8	8	8	8	8	8	8	8	8
19	109480	Wheel nut	16	16	16	16	16	16	16	16	16	16	16	16	16	16	16	16
20	602789	Seal	2	2	2	2	2	2	2	2	2	2	2	2	2	2	2	2
22	600670	Screw	4	4	4	4	4	4	4	4	4	4	4	4	4	4	4	4
23	603316	Planet wheel bracket	2	2	2	2	2	2	2	2	2	2	2	2	2	2	2	2
24	562513	Nut	16	16	16	16	16	16	16	16	16	16	16	16	16	16	16	16
25	562512	Stud, bolt	16	16	16	16	16	16	16	16	16	16	16	16	16	16	16	16
26	603640	Washer	2	2	2	2	2	2	2	2	2	2	2	2	2	2	2	2
30	603317	Planet wheel bracket kit	2	2	2	2	2	2	2	2	2	2	2	2	2	2	2	2

AX 1415

DRIVE AXLE, FRONT, DISC BRAKES

M30-2	M30-4	M30-2 H	M30-4 H
M40-2	M40-4	M40-2 H	M40-4 H
M50-2	M50-4	M50-2 H	M50-4 H
M60-2	M60-4	M60-2 H	M60-4 H
M30-2 L	M30-4 L	M30-2 H L	M30-4 H L
M40-2 L	M40-4 L	M40-2 H L	M40-4 H L
M50-2 L	M50-4 L	M50-2 H L	M50-4 H L
M60-2 L	M60-4 L	M60-2 H L	M60-4 H L

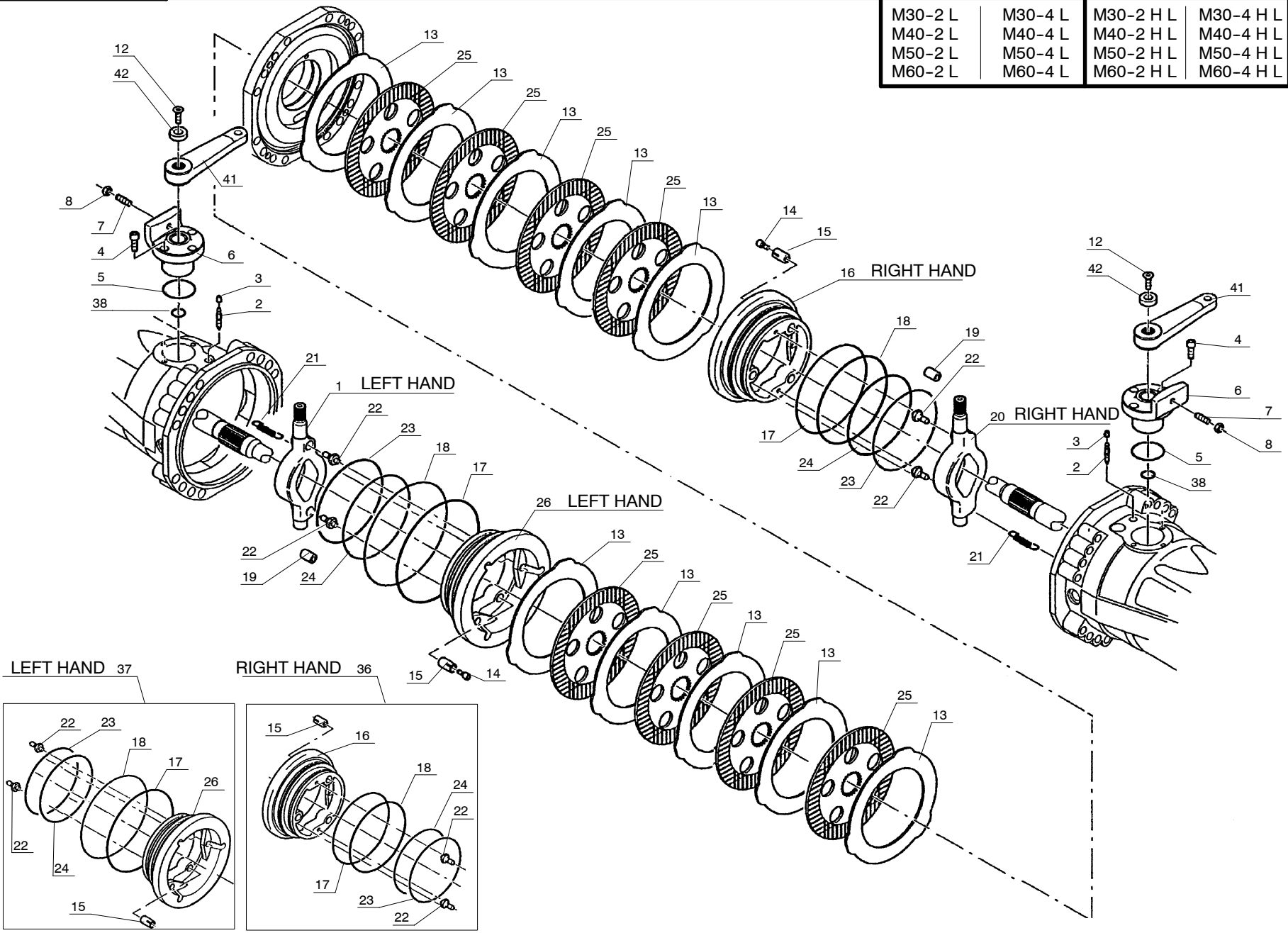

1	DRIVE AXLE, FRONT, DISC BRAKES												AX 1415						
	ITEM	PART NO.	DESCRIPTION	M30-2	M40-2	M50-2	M60-2	M30-2 H	M40-2 H	M50-2 H	M60-2 H	M30-2 L	M40-2 L	M50-2 L	M60-2 L	M30-2 H L	M40-2 H L	M50-2 H L	M60-2 H L
1	562547	Lever, LH	1	1	1	1	1	1	1	1	1	1	1	1	1	1	1	1	1
2	106010	Bleeder screw	2	2	2	2	2	2	2	2	2	2	2	2	2	2	2	2	2
3	107796	Plug	2	2	2	2	2	2	2	2	2	2	2	2	2	2	2	2	2
4	562548	Screw	6	6	6	6	6	6	6	6	6	6	6	6	6	6	6	6	6
5	475059	O-ring	2	2	2	2	2	2	2	2	2	2	2	2	2	2	2	2	2
6	602218	Reduction bushing	2	2	2	2	2	2	2	2	2	2	2	2	2	2	2	2	2
7	562550	Needle valve	2	2	2	2	2	2	2	2	2	2	2	2	2	2	2	2	2
8	133088	Nut	2	2	2	2	2	2	2	2	2	2	2	2	2	2	2	2	2
12	133199	Screw	2	2	2	2	2	2	2	2	2	2	2	2	2	2	2	2	2
13	562525	Intermediate disc	10	10	10	10	10	10	10	10	10	10	10	10	10	10	10	10	10
14	564234	Adjusting screw	6	6	6	6	6	6	6	6	6	6	6	6	6	6	6	6	6
15	602296	Spring	6	6	6	6	6	6	6	6	6	6	6	6	6	6	6	6	6
16	563905	Piston	1	1	1	1	1	1	1	1	1	1	1	1	1	1	1	1	1
17	562521	Anti-extrusion seal	2	2	2	2	2	2	2	2	2	2	2	2	2	2	2	2	2
18	562522	O-ring	2	2	2	2	2	2	2	2	2	2	2	2	2	2	2	2	2
19	107751	Centering pin	2	2	2	2	2	2	2	2	2	2	2	2	2	2	2	2	2
20	562554	Lever, RH	1	1	1	1	1	1	1	1	1	1	1	1	1	1	1	1	1
21	562520	Spring	6	6	6	6	6	6	6	6	6	6	6	6	6	6	6	6	6
22	107286	Needle valve	4	4	4	4	4	4	4	4	4	4	4	4	4	4	4	4	4
23	562523	Anti-extrusion seal	2	2	2	2	2	2	2	2	2	2	2	2	2	2	2	2	2
24	562524	O-ring	2	2	2	2	2	2	2	2	2	2	2	2	2	2	2	2	2
25	562516	Brake disc	8	8	8	8	8	8	8	8	8	8	8	8	8	8	8	8	8
26	563906	Piston	1	1	1	1	1	1	1	1	1	1	1	1	1	1	1	1	1
36	600582	Piston kit	1	1	1	1	1	1	1	1	1	1	1	1	1	1	1	1	1
37	600558	Piston kit	1	1	1	1	1	1	1	1	1	1	1	1	1	1	1	1	1
38	602007	O-ring	2	2	2	2	2	2	2	2	2	2	2	2	2	2	2	2	2
41	604253	Lever	2	2	2	2	2	2	2	2	2	2	2	2	2	2	2	2	2
42	106567	Spacer	2	2	2	2	2	2	2	2	2	2	2	2	2	2	2	2	2

AX 2520

STEER AXLE, 4WD

M30-4
M40-4
M50-4
M60-4

M30-4 H
M40-4 H
M50-4 H
M60-4 H

M30-4 L
M40-4 L
M50-4 L
M60-4 L

M30-4 H L
M40-4 H L
M50-4 H L
M60-4 H L

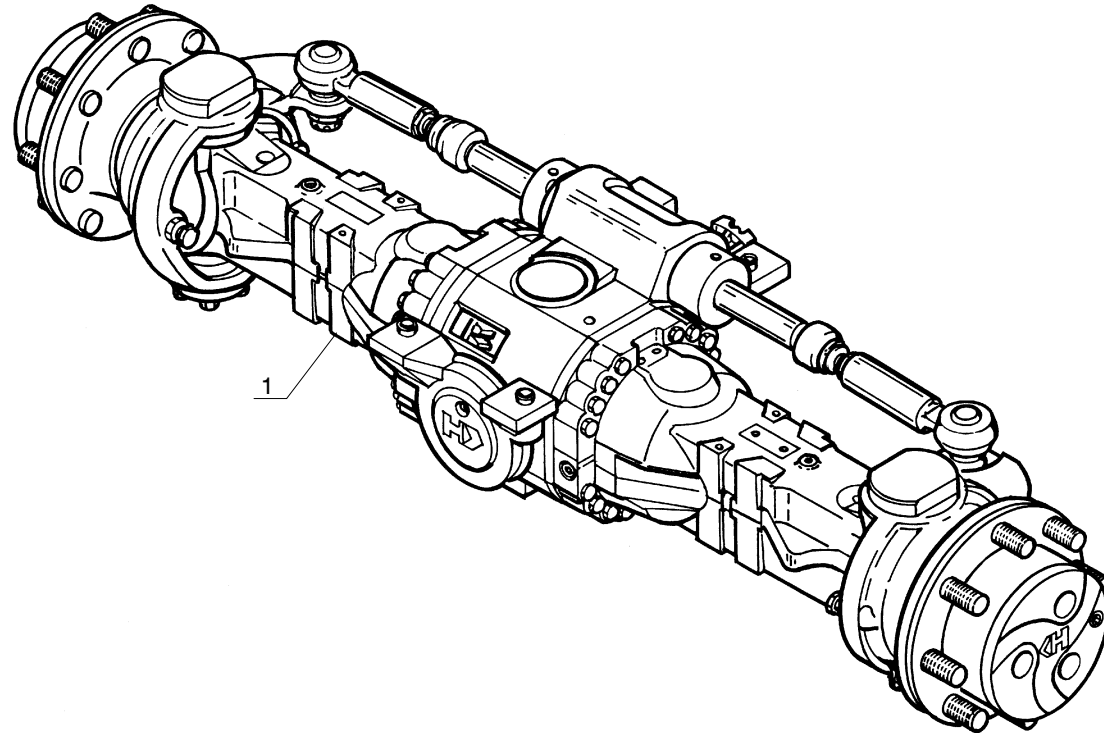

1	STEER AXLE, 4WD		QUANTITY / MODEL												AX 2520			
			M30-4	M40-4	M50-4	M60-4	M30-4 H	M40-4 H	M50-4 H	M60-4 H	M30-4 L	M40-4 L	M50-4 L	M60-4 L	M30-4 H L	M40-4 H L	M50-4 H L	M60-4 H L
ITEM	PART NO.	DESCRIPTION																
1	238216	Steer axle, 4WD (4-SPEED MODELS)	1	1	1	1							1	1	1	1		
1	801988	Steer axle, 4WD (HYDROSTATIC MODELS)					1	1	1	1							1	1

AX 1416

STEER AXLE CASING, 4WD

M30-4
M40-4
M50-4
M60-4

M30-4 H
M40-4 H
M50-4 H
M60-4 H

M30-4 L
M40-4 L
M50-4 L
M60-4 L

M30-4 H L
M40-4 H L
M50-4 H L
M60-4 H L

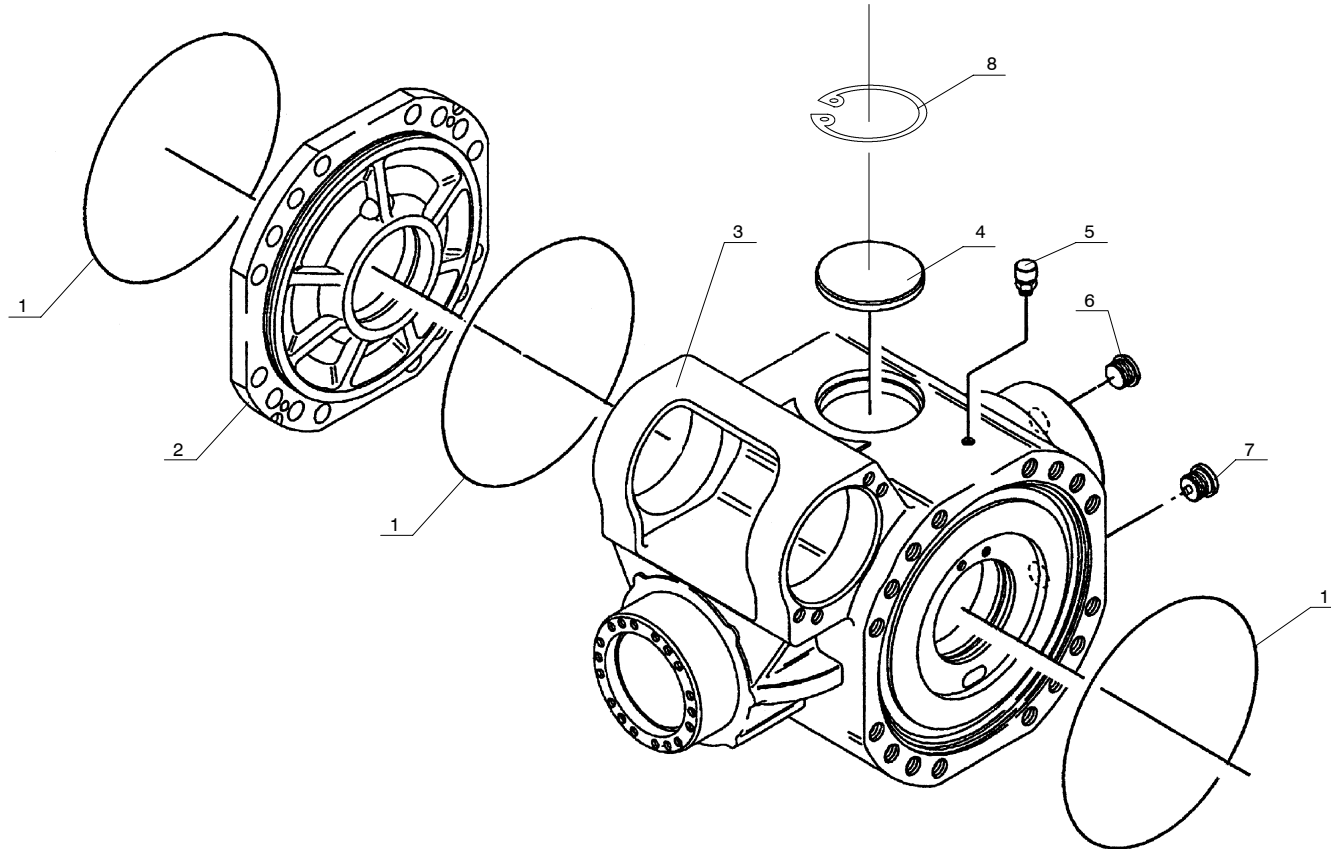

1	STEER AXLE CASING, 4WD		QUANTITY / MODEL											AX 1416				
			M30-4	M40-4	M50-4	M60-4	M30-4 H	M40-4 H	M50-4 H	M60-4 H	M30-4 L	M40-4 L	M50-4 L	M60-4 L	M30-4 H L	M40-4 H L	M50-4 H L	M60-4 H L
ITEM	PART NO.	DESCRIPTION																
1	106533	O-ring	3	3	3	3	3	3	3	3	3	3	3	3	3	3	3	3
2	562531	Housing	1	1	1	1	1	1	1	1	1	1	1	1	1	1	1	1
3A	562469	Central casing (STEER AXLE 238216)	1	1	1	1						1	1	1	1			
3B	603821	Central casing (STEER AXLE 801988)					1	1	1	1					1	1	1	1
4A	600549	Cover (STEER AXLE 238216)	1	1	1	1					1	1	1	1				
4B	602293	Cover (STEER AXLE 801988)					1	1	1	1					1	1	1	1
5	562470	Air breather	1	1	1	1	1	1	1	1	1	1	1	1	1	1	1	1
6	603638	Plug	1	1	1	1	1	1	1	1	1	1	1	1	1	1	1	1
7	603639	Magnetic plug	1	1	1	1	1	1	1	1	1	1	1	1	1	1	1	1
8	133044	Circlip (STEER AXLE 801988)					1	1	1	1					1	1	1	1

AX 1417

STEER AXLE DIFFERENTIAL, 4WD

M30-4
M40-4
M50-4
M60-4

M30-4 H
M40-4 H
M50-4 H
M60-4 H

M30-4 L
M40-4 L
M50-4 L
M60-4 L

M30-4 H L
M40-4 H L
M50-4 H L
M60-4 H L

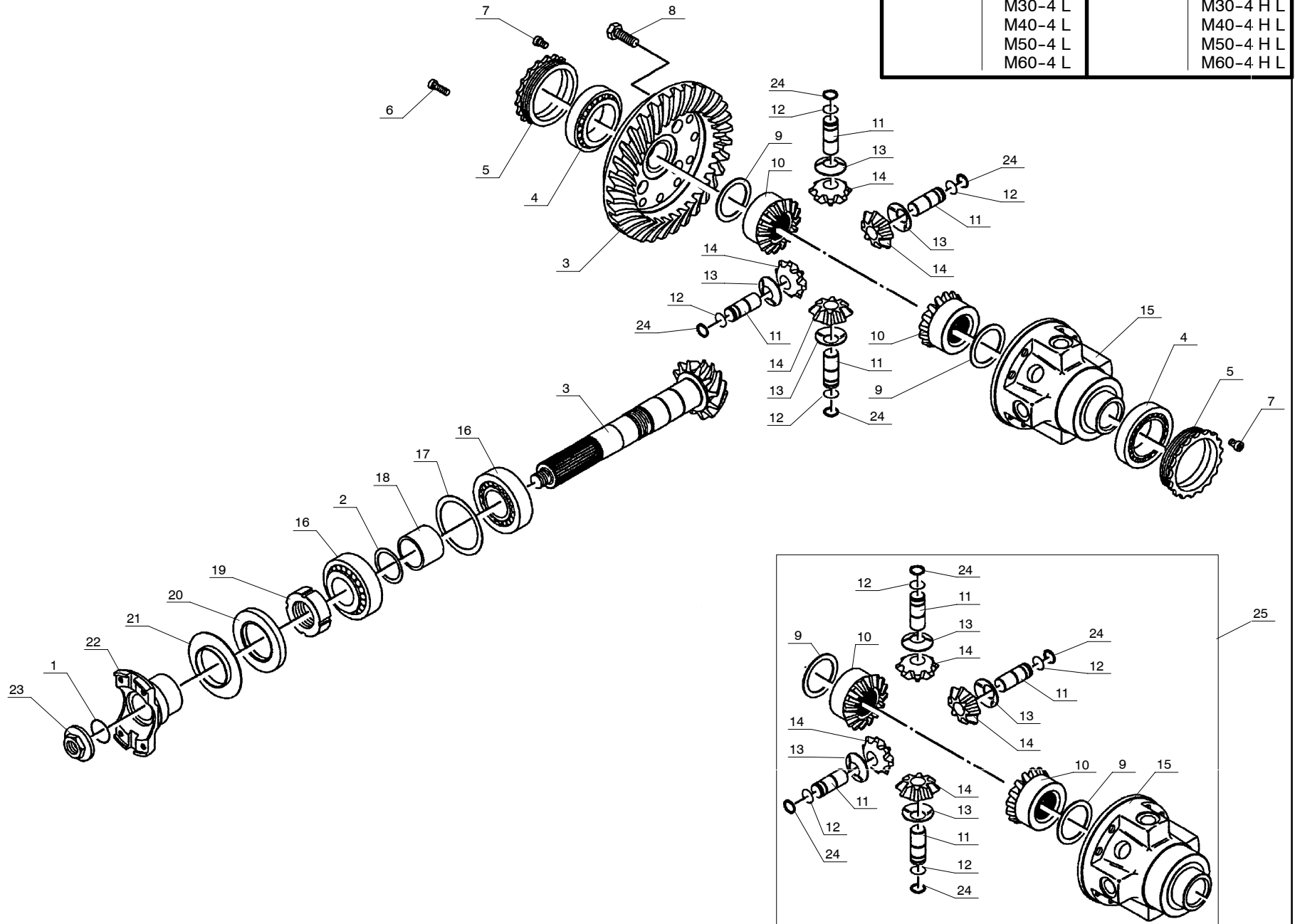

1	STEER AXLE DIFFERENTIAL, 4WD		QUANTITY / MODEL												AX 1417			
			M30-4	M40-4	M50-4	M60-4	M30-4 H	M40-4 H	M50-4 H	M60-4 H	M30-4 L	M40-4 L	M50-4 L	M60-4 L	M30-4 H L	M40-4 H L	M50-4 H L	M60-4 H L
ITEM	PART NO.	DESCRIPTION																
1	562472	O-ring	1	1	1	1	1	1	1	1	1	1	1	1	1	1	1	1
2	550556	Shim .15mm (.006 in)	A/R	A/R	A/R	A/R	A/R	A/R	A/R	A/R	A/R	A/R	A/R	A/R	A/R	A/R	A/R	A/R
2	550557	Shim .20mm (.008 in)	A/R	A/R	A/R	A/R	A/R	A/R	A/R	A/R	A/R	A/R	A/R	A/R	A/R	A/R	A/R	A/R
2	551616	Shim .40mm (.016 in)	A/R	A/R	A/R	A/R	A/R	A/R	A/R	A/R	A/R	A/R	A/R	A/R	A/R	A/R	A/R	A/R
2	552517	Shim .50mm (.020 in)	A/R	A/R	A/R	A/R	A/R	A/R	A/R	A/R	A/R	A/R	A/R	A/R	A/R	A/R	A/R	A/R
3	603648	Bevel drive gear	1	1	1	1	1	1	1	1	1	1	1	1	1	1	1	1
4	106550	Bearing	2	2	2	2	2	2	2	2	2	2	2	2	2	2	2	2
5	562474	Nut	2	2	2	2	2	2	2	2	2	2	2	2	2	2	2	2
6	133186	Screw	4	4	4	4	4	4	4	4	4	4	4	4	4	4	4	4
7	109912	Screw	2	2	2	2	2	2	2	2	2	2	2	2	2	2	2	2
8	601243	Screw	12	12	12	12	12	12	12	12	12	12	12	12	12	12	12	12
9	562476	Washer	2	2	2	2	2	2	2	2	2	2	2	2	2	2	2	2
10	562477	Planetary	2	2	2	2	2	2	2	2	2	2	2	2	2	2	2	2
11	562478	Axle	4	4	4	4	4	4	4	4	4	4	4	4	4	4	4	4
12	562479	Circlips	4	4	4	4	4	4	4	4	4	4	4	4	4	4	4	4
13	562480	Washer	4	4	4	4	4	4	4	4	4	4	4	4	4	4	4	4
14	562481	Planet wheel	4	4	4	4	4	4	4	4	4	4	4	4	4	4	4	4
15	562482	Differential housing	1	1	1	1	1	1	1	1	1	1	1	1	1	1	1	1
16	133069	Bearing	2	2	2	2	2	2	2	2	2	2	2	2	2	2	2	2
17	474298	Shim .20mm (.008 in)	A/R	A/R	A/R	A/R	A/R	A/R	A/R	A/R	A/R	A/R	A/R	A/R	A/R	A/R	A/R	A/R
17	474300	Shim .30mm (.012 in)	A/R	A/R	A/R	A/R	A/R	A/R	A/R	A/R	A/R	A/R	A/R	A/R	A/R	A/R	A/R	A/R
17	551615	Shim .15mm (.006 in)	A/R	A/R	A/R	A/R	A/R	A/R	A/R	A/R	A/R	A/R	A/R	A/R	A/R	A/R	A/R	A/R
17	552516	Shim .10mm (.004 in)	A/R	A/R	A/R	A/R	A/R	A/R	A/R	A/R	A/R	A/R	A/R	A/R	A/R	A/R	A/R	A/R
18	562483	Spacer	1	1	1	1	1	1	1	1	1	1	1	1	1	1	1	1
19	133570	Nut	1	1	1	1	1	1	1	1	1	1	1	1	1	1	1	1
20	107293	Seal	1	1	1	1	1	1	1	1	1	1	1	1	1	1	1	1

AX 1418

STEER AXLE REDUCTION GEAR, 4WD

M30-4
M40-4
M50-4
M60-4

M30-4 H
M40-4 H
M50-4 H
M60-4 H

M30-4 L
M40-4 L
M50-4 L
M60-4 L

M30-4 H L
M40-4 H L
M50-4 H L
M60-4 H L

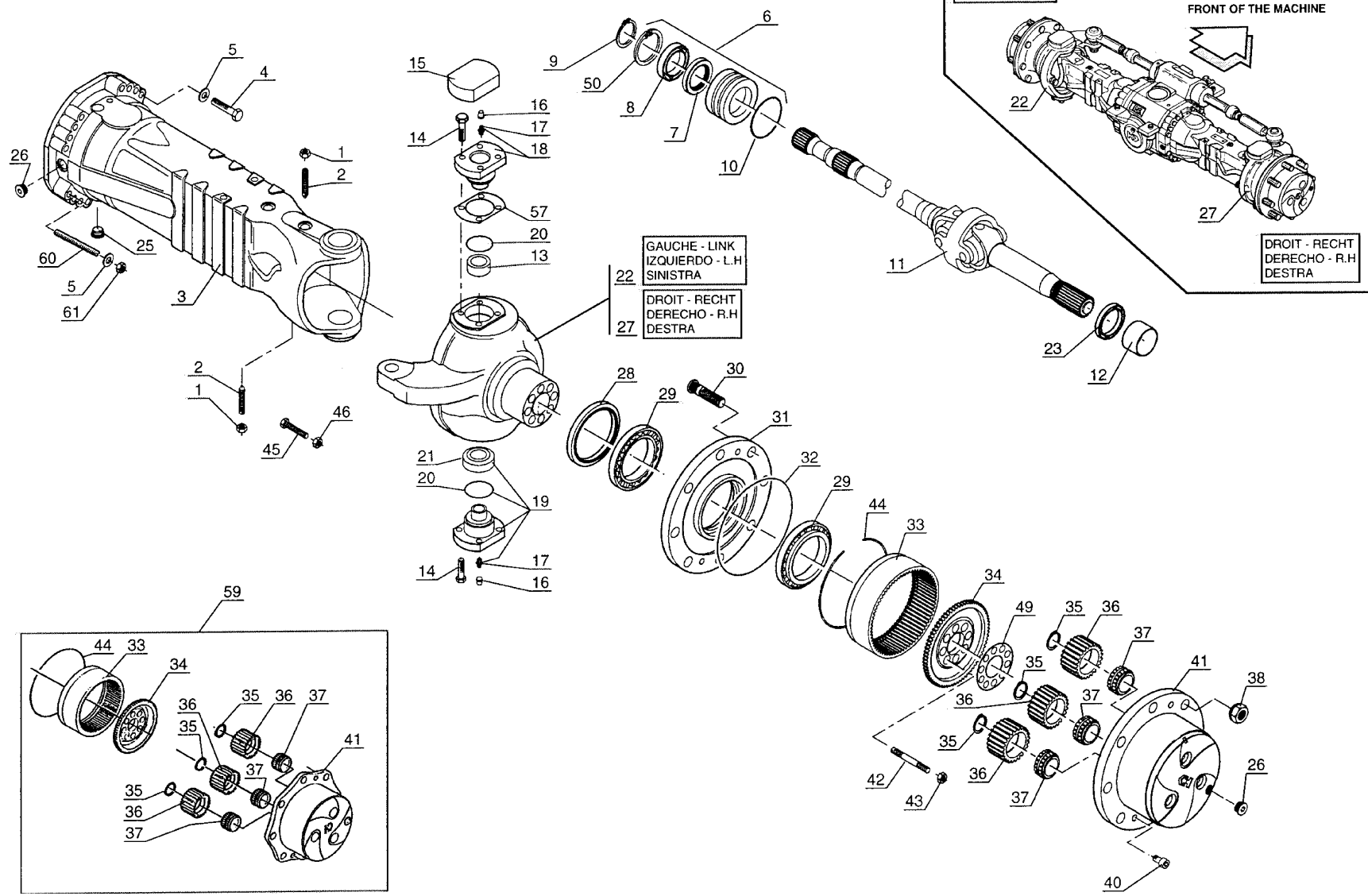

1	STEER AXLE REDUCTION GEAR, 4WD		QUANTITY / MODEL												AX 1418			
			M30-4	M40-4	M50-4	M60-4	M30-4 H	M40-4 H	M50-4 H	M60-4 H	M30-4 L	M40-4 L	M50-4 L	M60-4 L	M30-4 H L	M40-4 H L	M50-4 H L	M60-4 H L
ITEM	PART NO.	DESCRIPTION																
1	133090	Nut	2	2	2	2	2	2	2	2	2	2	2	2	2	2	2	2
2	562750	Screw	2	2	2	2	2	2	2	2	2	2	2	2	2	2	2	2
3	603649	Lateral axle case	2	2	2	2	2	2	2	2	2	2	2	2	2	2	2	2
4A	562489	Bolt (STEER AXLE 238216)	28	28	28	28					28	28	28	28				
4B	702138	Bolt (STEER AXLE 801988)					28	28	28	28					28	28	28	28
5	562490	Washer	32	32	32	32	32	32	32	32	32	32	32	32	32	32	32	32
6	563903	Flange	2	2	2	2	2	2	2	2	2	2	2	2	2	2	2	2
7	108100	Seal	2	2	2	2	2	2	2	2	2	2	2	2	2	2	2	2
8	105101	Bearing	2	2	2	2	2	2	2	2	2	2	2	2	2	2	2	2
9	105424	Circlips	2	2	2	2	2	2	2	2	2	2	2	2	2	2	2	2
10	562752	O-ring	2	2	2	2	2	2	2	2	2	2	2	2	2	2	2	2
11	603650	Axle, Cardan	2	2	2	2	2	2	2	2	2	2	2	2	2	2	2	2
12	477847	Bushing	2	2	2	2	2	2	2	2	2	2	2	2	2	2	2	2
13	603651	Bushing	2	2	2	2	2	2	2	2	2	2	2	2	2	2	2	2
14	562475	Screw	20	20	20	20	20	20	20	20	20	20	20	20	20	20	20	20
15	600559	Cover	2	2	2	2	2	2	2	2	2	2	2	2	2	2	2	2
16	107796	Plug	4	4	4	4	4	4	4	4	4	4	4	4	4	4	4	4
17	133103	Greaser	4	4	4	4	4	4	4	4	4	4	4	4	4	4	4	4
18	564903	Pivot pin	2	2	2	2	2	2	2	2	2	2	2	2	2	2	2	2
19	564898	Pivot pin	2	2	2	2	2	2	2	2	2	2	2	2	2	2	2	2
20	562499	Seal	4	4	4	4	4	4	4	4	4	4	4	4	4	4	4	4
21	562500	Bushing	2	2	2	2	2	2	2	2	2	2	2	2	2	2	2	2
22A	603652	LH steering case (STEER AXLE 238216)	1	1	1	1					1	1	1	1				
22B	496428	LH steering case (STEER AXLE 801988)					1	1	1	1					1	1	1	1
23	603653	Seal	2	2	2	2	2	2	2	2	2	2	2	2	2	2	2	2
25	603639	Magnetic plug	2	2	2	2	2	2	2	2	2	2	2	2	2	2	2	2
26	603638	Plug	4	4	4	4	4	4	4	4	4	4	4	4	4	4	4	4
27A	603654	RH steering case (STEER AXLE 238216)	1	1	1	1					1	1	1	1				
27B	496429	RH steering case (STEER AXLE 801988)					1	1	1	1					1	1	1	1

99.00

2	STEER AXLE REDUCTION GEAR, 4WD		QUANTITY / MODEL												AX 1418			
			M30-4	M40-4	M50-4	M60-4	M30-4 H	M40-4 H	M50-4 H	M60-4 H	M30-4 L	M40-4 L	M50-4 L	M60-4 L	M30-4 H L	M40-4 H L	M50-4 H L	M60-4 H L
ITEM	PART NO.	DESCRIPTION																
28A	562503	Seal (STEER AXLE 238216)	2	2	2	2					2	2	2	2				
28B	604656	Seal (STEER AXLE 801988)					2	2	2	2					2	2	2	2
29	562504	Bearing	4	4	4	4	4	4	4	4	4	4	4	4	4	4	4	4
30	473575	Wheel stud	16	16	16	16	16	16	16	16	16	16	16	16	16	16	16	16
31	601246	Wheel hub	2	2	2	2	2	2	2	2	2	2	2	2	2	2	2	2
32	106533	O-ring	2	2	2	2	2	2	2	2	2	2	2	2	2	2	2	2
33	564133	Gear ring	2	2	2	2	2	2	2	2	2	2	2	2	2	2	2	2
34	565998	Ring gear bracket	2	2	2	2	2	2	2	2	2	2	2	2	2	2	2	2
35	562508	Circlips	6	6	6	6	6	6	6	6	6	6	6	6	6	6	6	6
36	562509	Planet wheel	6	6	6	6	6	6	6	6	6	6	6	6	6	6	6	6
37	562510	Bearing	6	6	6	6	6	6	6	6	6	6	6	6	6	6	6	6
38	247292	Wheel nut	16	16	16	16	16	16	16	16	16	16	16	16	16	16	16	16
40	600670	Screw	4	4	4	4	4	4	4	4	4	4	4	4	4	4	4	4
41A	602220	Planet gear carrier (STEER AXLE 238216)	2	2	2	2					2	2	2	2				
41B	604252	Planet gear carrier (STEER AXLE 801988)					2	2	2	2					2	2	2	2
42	562512	Stud, bolt	16	16	16	16	16	16	16	16	16	16	16	16	16	16	16	16
43	562513	Nut	16	16	16	16	16	16	16	16	16	16	16	16	16	16	16	16
44	562514	Circlips	2	2	2	2	2	2	2	2	2	2	2	2	2	2	2	2
45A	474312	Adjusting screw (STEER AXLE 238216)	4	4	4	4					4	4	4	4				
45B	602219	Adjusting screw (STEER AXLE 801988)					4	4	4	4					4	4	4	4
46	474313	Nut	4	4	4	4	4	4	4	4	4	4	4	4	4	4	4	4
49	562515	Locking plate	2	2	2	2	2	2	2	2	2	2	2	2	2	2	2	2
50	133044	Circlips	2	2	2	2	2	2	2	2	2	2	2	2	2	2	2	2
57A	564679	Shim .15mm (.006 in) (STEER AXLE 238216)	A/R	A/R	A/R	A/R					A/R	A/R	A/R	A/R				
57A	564680	Shim .20mm (.008 in) (STEER AXLE 238216)	A/R	A/R	A/R	A/R					A/R	A/R	A/R	A/R				
57A	564681	Shim .50mm (.020 in) (STEER AXLE 238216)	A/R	A/R	A/R	A/R					A/R	A/R	A/R	A/R				

AX 1419

STEERING CYLINDER, 4WD STEER AXLE

M30-4
M40-4
M50-4
M60-4

M30-4 H
M40-4 H
M50-4 H
M60-4 H

M30-4 L
M40-4 L
M50-4 L
M60-4 L

M30-4 H L
M40-4 H L
M50-4 H L
M60-4 H L

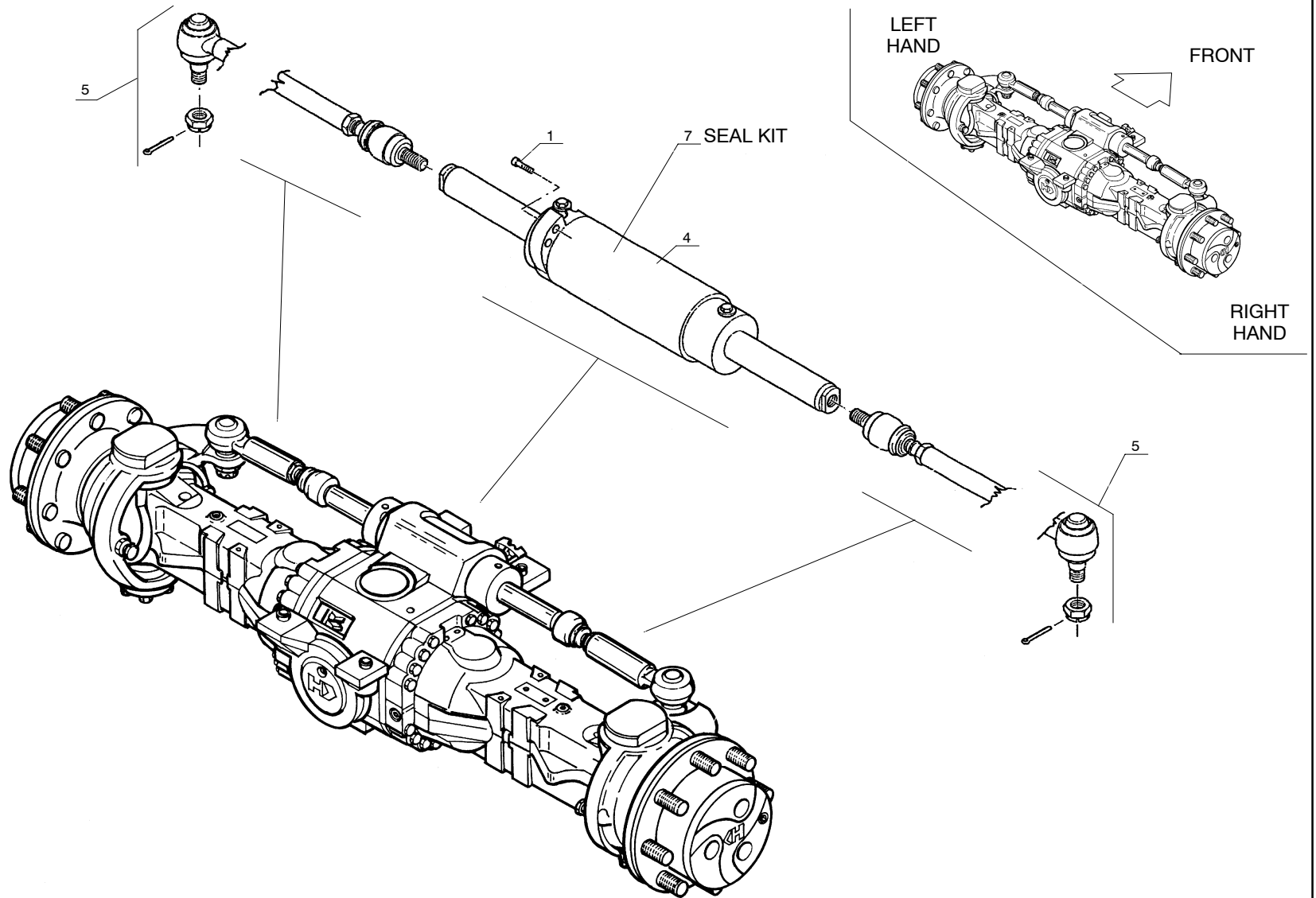

1	STEERING CYLINDER, 4WD STEER AXLE		QUANTITY / MODEL												AX 1419			
			M30-4	M40-4	M50-4	M60-4	M30-4 H	M40-4 H	M50-4 H	M60-4 H	M30-4 L	M40-4 L	M50-4 L	M60-4 L	M30-4 H L	M40-4 H L	M50-4 H L	M60-4 H L
ITEM	PART NO.	DESCRIPTION																
1	562526	Screw	4	4	4	4	4	4	4	4	4	4	4	4	4	4	4	4
4A	603656	Steering cylinder (STEER AXLE 238216)	1	1	1	1						1	1	1	1			
4B	702067	Steering cylinder (STEER AXLE 801988)					1	1	1	1					1	1	1	1
5	603657	Linked tie rod	2	2	2	2	2	2	2	2	2	2	2	2	2	2	2	2
7A	603681	Seal kit (STEER AXLE 238216)	1	1	1	1						1	1	1	1			
7B	702147	Seal kit (STEER AXLE 801988)					1	1	1	1					1	1	1	1

100.00

AX 1420

STEER AXLE SUPPORT BRACKET, 4WD

M30-4
M40-4
M50-4
M60-4

M30-4 H
M40-4 H
M50-4 H
M60-4 H

M30-4 L
M40-4 L
M50-4 L
M60-4 L

M30-4 H L
M40-4 H L
M50-4 H L
M60-4 H L

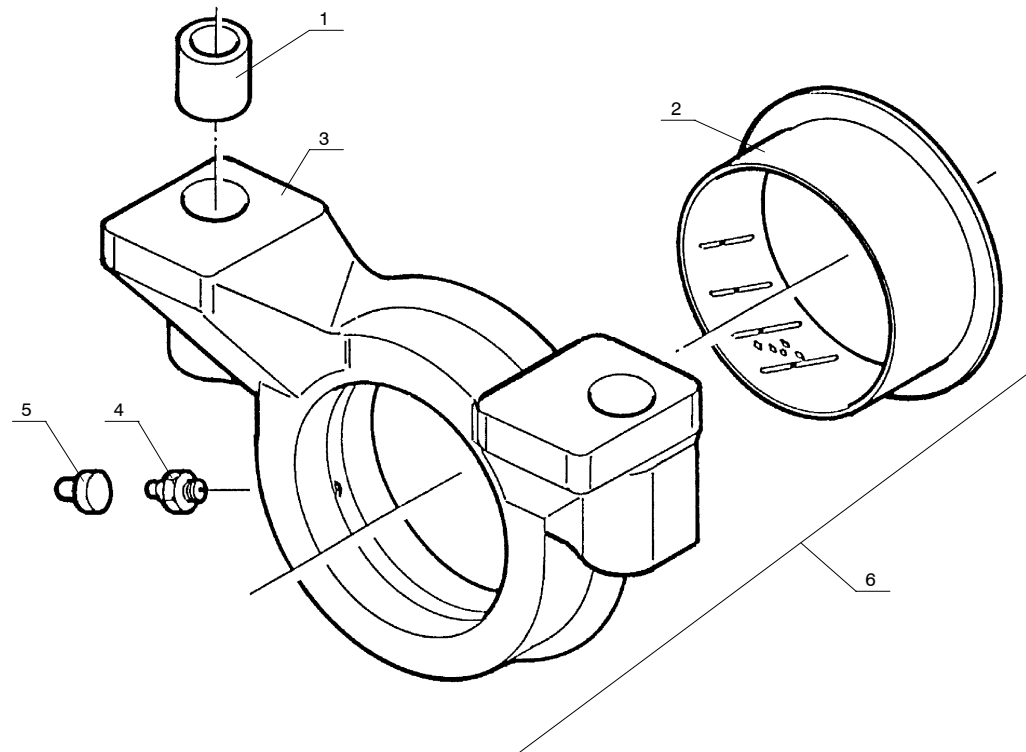

1	STEER AXLE SUPPORT BRACKET, 4WD		QUANTITY / MODEL												AX 1420			
			M30-4	M40-4	M50-4	M60-4	M30-4 H	M40-4 H	M50-4 H	M60-4 H	M30-4 L	M40-4 L	M50-4 L	M60-4 L	M30-4 H L	M40-4 H L	M50-4 H L	M60-4 H L
ITEM	PART NO.	DESCRIPTION																
1	477964	Coupling	4	4	4	4	4	4	4	4	4	4	4	4	4	4	4	4
2	477538	Bushing	2	2	2	2	2	2	2	2	2	2	2	2	2	2	2	2
3	564693	Axle bracket	2	2	2	2	2	2	2	2	2	2	2	2	2	2	2	2
4	133103	Greaser	2	2	2	2	2	2	2	2	2	2	2	2	2	2	2	2
5	107796	Plug	2	2	2	2	2	2	2	2	2	2	2	2	2	2	2	2
6	601561	Axle bracket	2	2	2	2	2	2	2	2	2	2	2	2	2	2	2	2

BC 108

HYDROSTATIC MOTOR

M30-2 H	M30-4 H
M40-2 H	M40-4 H
M50-2 H	M50-4 H
M60-2 H	M60-4 H
M30-2 H L	M30-4 H L
M40-2 H L	M40-4 H L
M50-2 H L	M50-4 H L
M60-2 H L	M60-4 H L

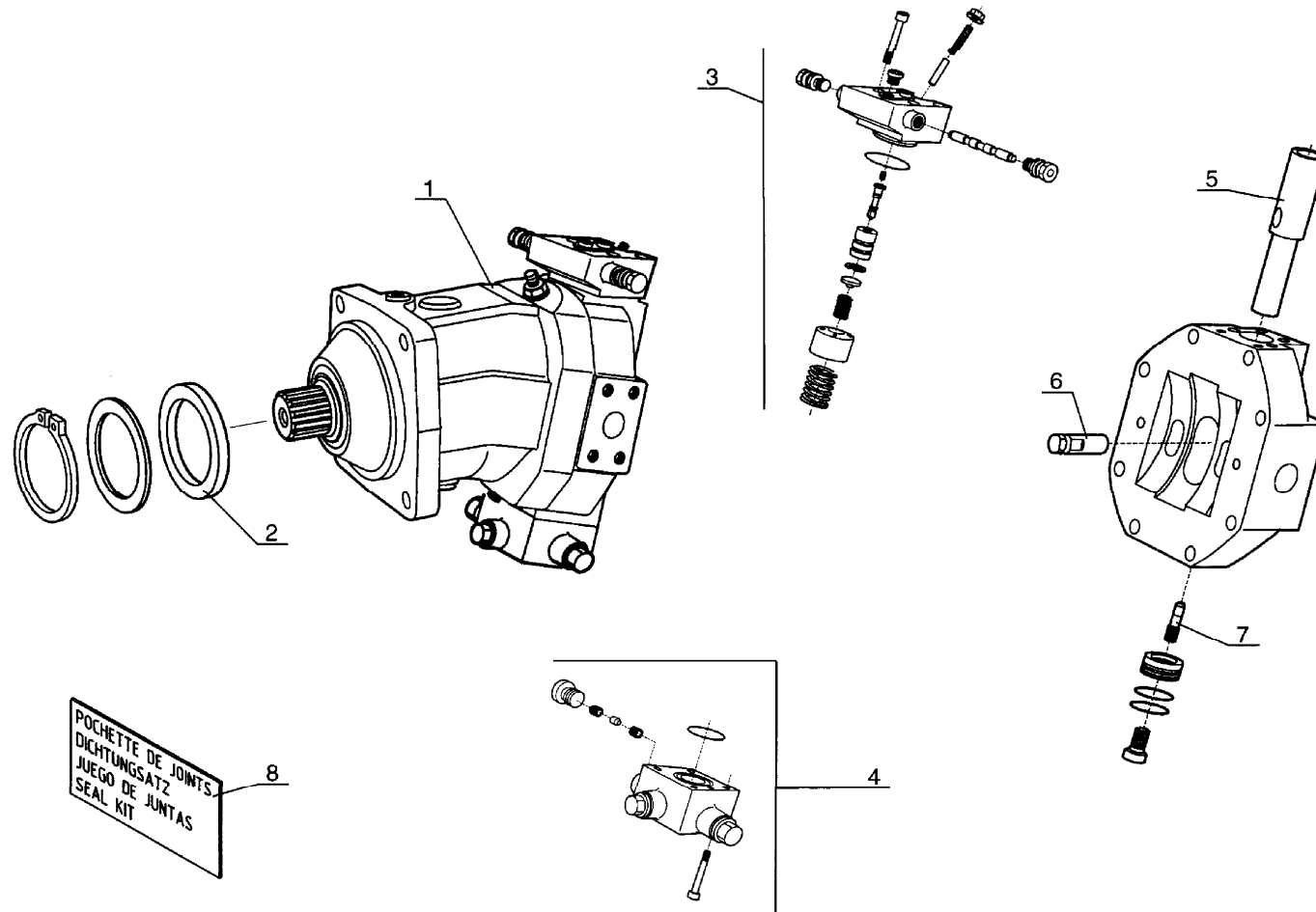

1	HYDROSTATIC MOTOR		QUANTITY / MODEL								BC 108			
											M30-4 H L	M40-4 H L	M50-4 H L	M60-4 H L
ITEM	PART NO.	DESCRIPTION	M30-2 H	M40-2 H	M50-2 H	M60-2 H					M30-2 H L	M40-2 H L	M50-2 H L	M60-2 H L
1	208701	Hydrostatic pump assembly	1	1	1	1					1	1	1	1
2	561198	Seal	1	1	1	1					1	1	1	1
3	561187	Control parts	1	1	1	1					1	1	1	1
4	552608	Flushing and boost pressure valve	1	1	1	1					1	1	1	1
5	562317	Piston	1	1	1	1					1	1	1	1
6	562318	Swivel pin	1	1	1	1					1	1	1	1
7	562319	Screw	1	1	1	1					1	1	1	1
8	562320	Seal kit	1	1	1	1					1	1	1	1

BC 139

TRANSMISSION, HYDROSTATIC PUMP

M30-2 H	M30-4 H
M40-2 H	M40-4 H
M50-2 H	M50-4 H
M60-2 H	M60-4 H
M30-2 H L	M30-4 H L
M40-2 H L	M40-4 H L
M50-2 H L	M50-4 H L
M60-2 H L	M60-4 H L

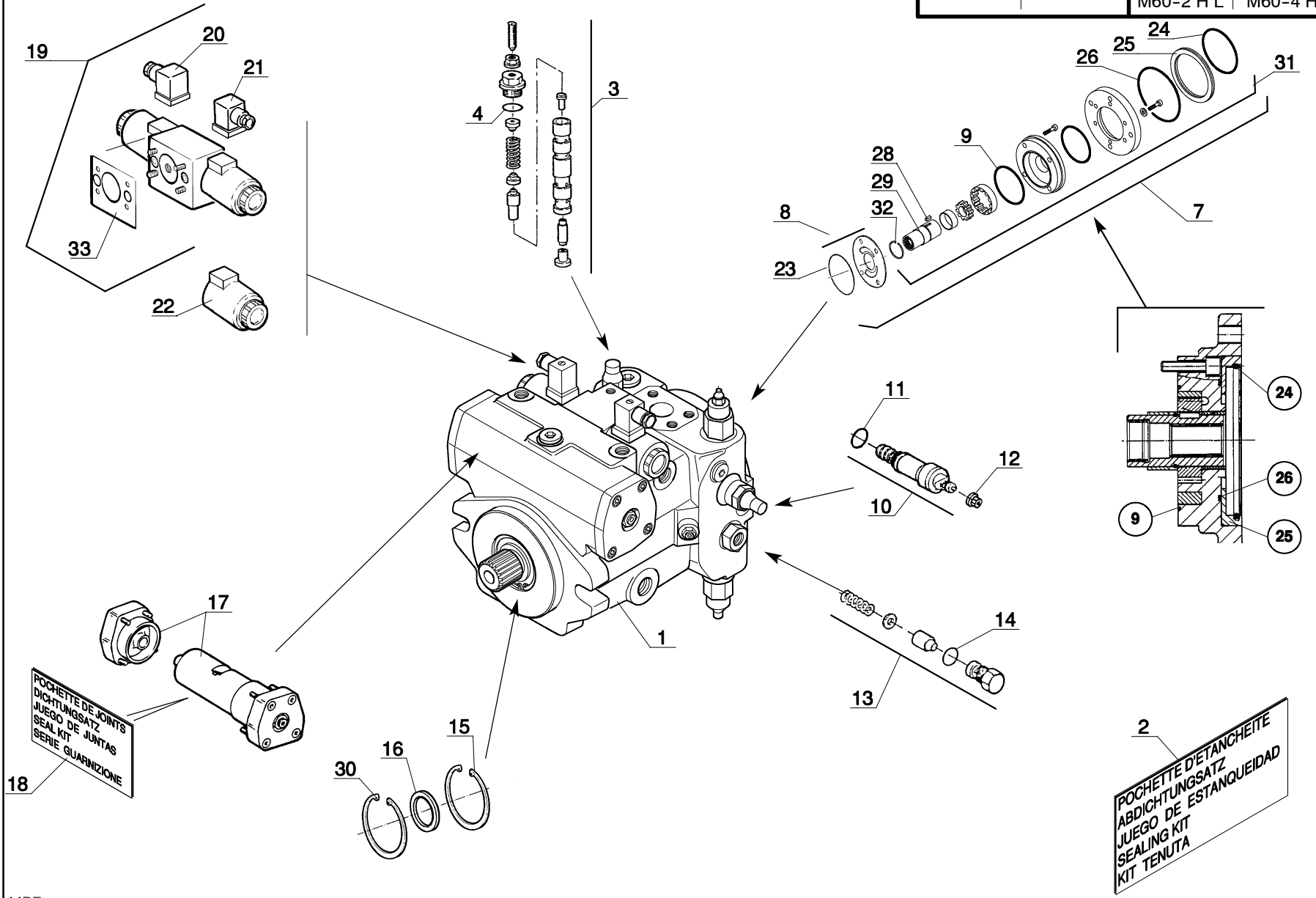

POCHETTE DE JOINTS
DICHTUNGSATZ
JUEGO DE JUNTAS
SEAL KIT
SERIE GUARNIZIONE

POCHETTE D'ETANCHEITE
ABDICHTUNGSATZ
JUEGO DE ESTANQUEIDAD
SEALING KIT
KIT TENUTA

1	TRANSMISSION, HYDROSTATIC PUMP		QUANTITY / MODEL								BC 139			
											M30-4 H L	M40-4 H L	M50-4 H L	M60-4 H L
ITEM	PART NO.	DESCRIPTION	M30-2 H	M40-2 H	M50-2 H	M60-2 H					M30-2 H L	M40-2 H L	M50-2 H L	M60-2 H L
1	802903	Hydrostatic pump, complete	1	1	1	1					1	1	1	1
2	603534	Seal kit	1	1	1	1					1	1	1	1
3	552629	Valve	1	1	1	1					1	1	1	1
4	201149	O-ring	1	1	1	1					1	1	1	1
5														
6														
7	602061	Boost pump	1	1	1	1					1	1	1	1
8	601589	Friction lining	1	1	1	1					1	1	1	1
9	201198	Seal	1	1	1	1					1	1	1	1
10	458502	Control valve	1	1	1	1					1	1	1	1
11	401831	O-ring	1	1	1	1					1	1	1	1
12	409248	Nut	1	1	1	1					1	1	1	1
13	601590	Relief valve	1	1	1	1					1	1	1	1
14	601594	O-ring	1	1	1	1					1	1	1	1
15	552634	Circlips	1	1	1	1					1	1	1	1
16	602062	Seal	1	1	1	1					1	1	1	1
17	601593	Positioning piston	1	1	1	1					1	1	1	1
18	601597	Seal kit	1	1	1	1					1	1	1	1
19	602063	Valve bank	1	1	1	1					1	1	1	1
20	58112	Connection test	1	1	1	1					1	1	1	1
21	58113	Connection test	1	1	1	1					1	1	1	1
22	602064	Solenoid	2	2	2	2					2	2	2	2
23	201198	Seal	1	1	1	1					1	1	1	1
24	474783	O-ring	1	1	1	1					1	1	1	1
25	552622	Bushing	1	1	1	1					1	1	1	1
26	201199	O-ring	1	1	1	1					1	1	1	1
28	600525	Key	1	1	1	1					1	1	1	1

2	TRANSMISSION, HYDROSTATIC PUMP		QUANTITY / MODEL								BC 139							
							M30-4 H	M40-4 H	M50-4 H	M60-4 H					M30-4 H L	M40-4 H L	M50-4 H L	M60-4 H L
ITEM	PART NO.	DESCRIPTION					M30-2 H	M40-2 H	M50-2 H	M60-2 H					M30-2 H L	M40-2 H L	M50-2 H L	M60-2 H L
29	602065	Coupling					1	1	1	1					1	1	1	1
30	601592	Circlips					1	1	1	1					1	1	1	1
31	200944	Boost pump					1	1	1	1					1	1	1	1
32	201197	Snap ring					1	1	1	1					1	1	1	1
33	552504	Gasket					1	1	1	1					1	1	1	1

BP 177

TRANSMISSION, 4-SPEED, 2WD

M30-2			
M40-2			
M50-2			
M60-2			
M30-2 L			
M40-2 L			
M50-2 L			
M60-2 L			

SEE 4 AA 50 FOR DIPSTICK ASSEMBLY

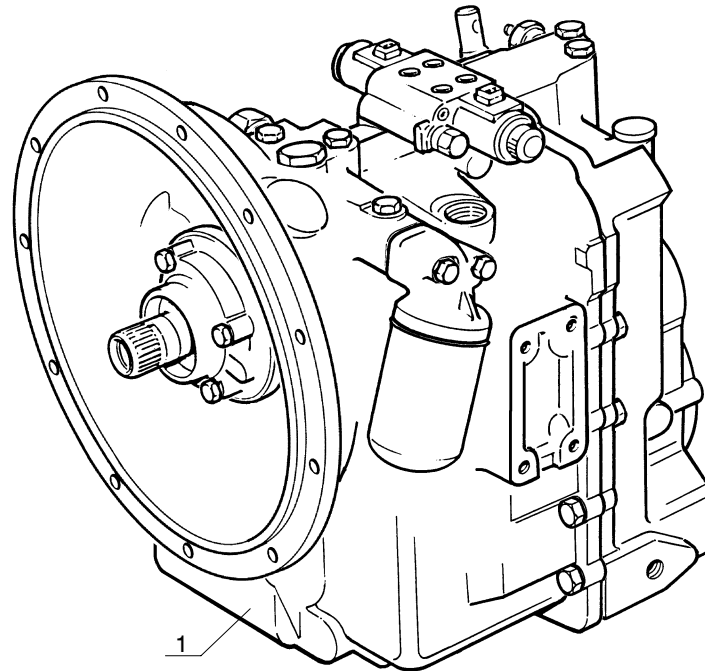

			QUANTITY / MODEL								BP 177			
1			TRANSMISSION, 4-SPEED, 2WD											
ITEM	PART NO.	DESCRIPTION	M30-2	M40-2	M50-2	M60-2	M30-2 L	M40-2 L	M50-2 L	M60-2 L				
1	222572	Gear box, complete	1	1	1	1	1	1	1	1				

104.00

BP 178

TRANSMISSION, 4-SPEED, 2WD, EXTERNAL COMPONENTS

M30-2			
M40-2			
M50-2			
M60-2			
M30-2 L			
M40-2 L			
M50-2 L			
M60-2 L			

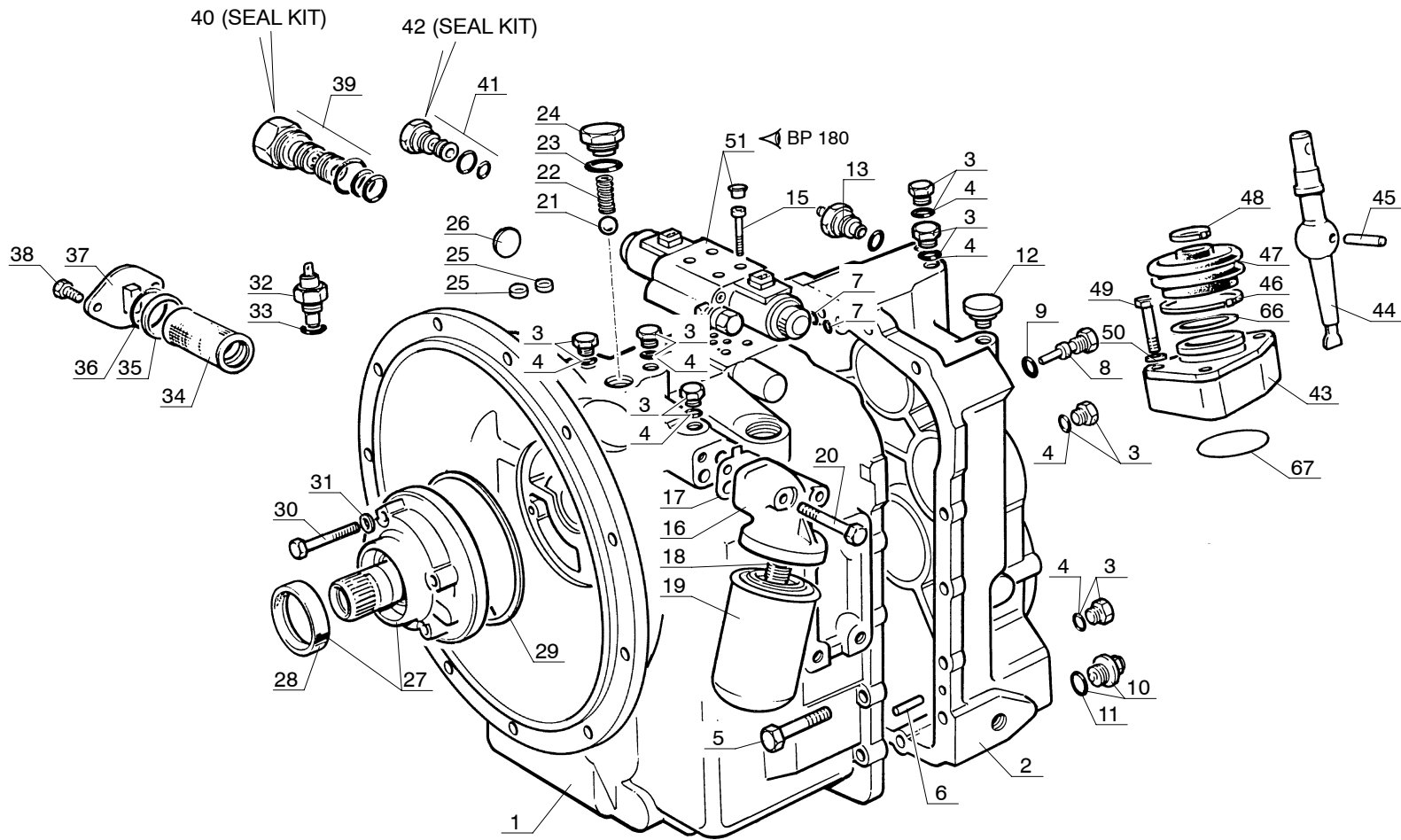

FOR ADDITIONAL SEAL KITS SEE ITEMS:
60 - 61 - 62 - 63 - 64 - 65
ON THE FOLLOWING PAGES

1	TRANSMISSION, 4-SPEED, 2WD, EXTERNAL COMPONENTS		QUANTITY / MODEL								BP 178			
			M30-2	M40-2	M50-2	M60-2	M30-2 L	M40-2 L	M50-2 L	M60-2 L				
ITEM	PART NO.	DESCRIPTION	M30-2	M40-2	M50-2	M60-2	M30-2 L	M40-2 L	M50-2 L	M60-2 L				
1	561840	Transmission housing	1	1	1	1	1	1	1	1				
2	561841	Transmission rear case	1	1	1	1	1	1	1	1				
3	550705	Plug	13	13	13	13	13	13	13	13				
4	109657	O-ring	13	13	13	13	13	13	13	13				
5	109727	Screw	16	16	16	16	16	16	16	16				
6	109703	Stud bolt	2	2	2	2	2	2	2	2				
7	561833	O-ring	3	3	3	3	3	3	3	3				
8	561835	Plug	1	1	1	1	1	1	1	1				
9	109657	O-ring	1	1	1	1	1	1	1	1				
10	473366	Drain plug	1	1	1	1	1	1	1	1				
11	473915	O-ring	1	1	1	1	1	1	1	1				
12	109705	Air breather	1	1	1	1	1	1	1	1				
13	549100	Oil pressure switch	1	1	1	1	1	1	1	1				
15	561829	Screw	4	4	4	4	4	4	4	4				
16	561837	Filter housing	1	1	1	1	1	1	1	1				
17	109646	Gasket	1	1	1	1	1	1	1	1				
18	109658	Connection	1	1	1	1	1	1	1	1				
19	561749	Oil filter	1	1	1	1	1	1	1	1				
20	109728	Screw	2	2	2	2	2	2	2	2				
21	561836	Ball	1	1	1	1	1	1	1	1				
22	561765	Spring	1	1	1	1	1	1	1	1				
23	561827	O-ring	1	1	1	1	1	1	1	1				
24	561828	Plug	1	1	1	1	1	1	1	1				
25	561822	Plug	2	2	2	2	2	2	2	2				
26	561834	Plug	1	1	1	1	1	1	1	1				
27	561930	Pump, complete	1	1	1	1	1	1	1	1				
28	109690	Seal	1	1	1	1	1	1	1	1				
29	109676	O-ring	1	1	1	1	1	1	1	1				

105.00

2	TRANSMISSION, 4-SPEED, 2WD, EXTERNAL COMPONENTS		QUANTITY / MODEL								BP 178					
			M30-2	M40-2	M50-2	M60-2	M30-2 L	M40-2 L	M50-2 L	M60-2 L						
ITEM	PART NO.	DESCRIPTION														
30	561760	Screw	4	4	4	4	4	4	4	4						
31	109659	Washer	4	4	4	4	4	4	4	4						
32	552502	Oil temp sensor	1	1	1	1	1	1	1	1						
33	109657	O-ring	1	1	1	1	1	1	1	1						
34	109565	Suction strainer	1	1	1	1	1	1	1	1						
35	550626	Washer	1	1	1	1	1	1	1	1						
36	550627	O-ring	1	1	1	1	1	1	1	1						
37	473368	Cover	1	1	1	1	1	1	1	1						
38	109732	Screw	2	2	2	2	2	2	2	2						
39	561830	Pressure regulation valve	1	1	1	1	1	1	1	1						
40	561946	Seal kit	1	1	1	1	1	1	1	1						
41	561823	Over pressure valve	1	1	1	1	1	1	1	1						
42	561945	Seal kit	1	1	1	1	1	1	1	1						
43	562040	Upper seat	1	1	1	1	1	1	1	1						
44	561816	Gear lever foot	1	1	1	1	1	1	1	1						
45	109681	Pin	1	1	1	1	1	1	1	1						
46	561820	Clamp	1	1	1	1	1	1	1	1						
47	109612	Dust cover	1	1	1	1	1	1	1	1						
48	561821	Clamp	1	1	1	1	1	1	1	1						
49	561760	Screw	3	3	3	3	3	3	3	3						
50	561761	Washer	3	3	3	3	3	3	3	3						
51	600792	Electrical control valve	1	1	1	1	1	1	1	1						
60	561931	Pump kit	A/R	A/R	A/R	A/R	A/R	A/R	A/R	A/R						
61	561934	Small parts kit	A/R	A/R	A/R	A/R	A/R	A/R	A/R	A/R						
62	562002	Seal kit	A/R	A/R	A/R	A/R	A/R	A/R	A/R	A/R						
63	562003	Seal kit	A/R	A/R	A/R	A/R	A/R	A/R	A/R	A/R						
64	562006	Valve kit	A/R	A/R	A/R	A/R	A/R	A/R	A/R	A/R						
65	561942	Complete repair kit	A/R	A/R	A/R	A/R	A/R	A/R	A/R	A/R						
66	600365	Gasket	1	1	1	1	1	1	1	1						
67	600366	O-ring	1	1	1	1	1	1	1	1						

M30-2	M30-2 L
M40-2	M40-2 L
M50-2	M50-2 L
M60-2	M60-2 L

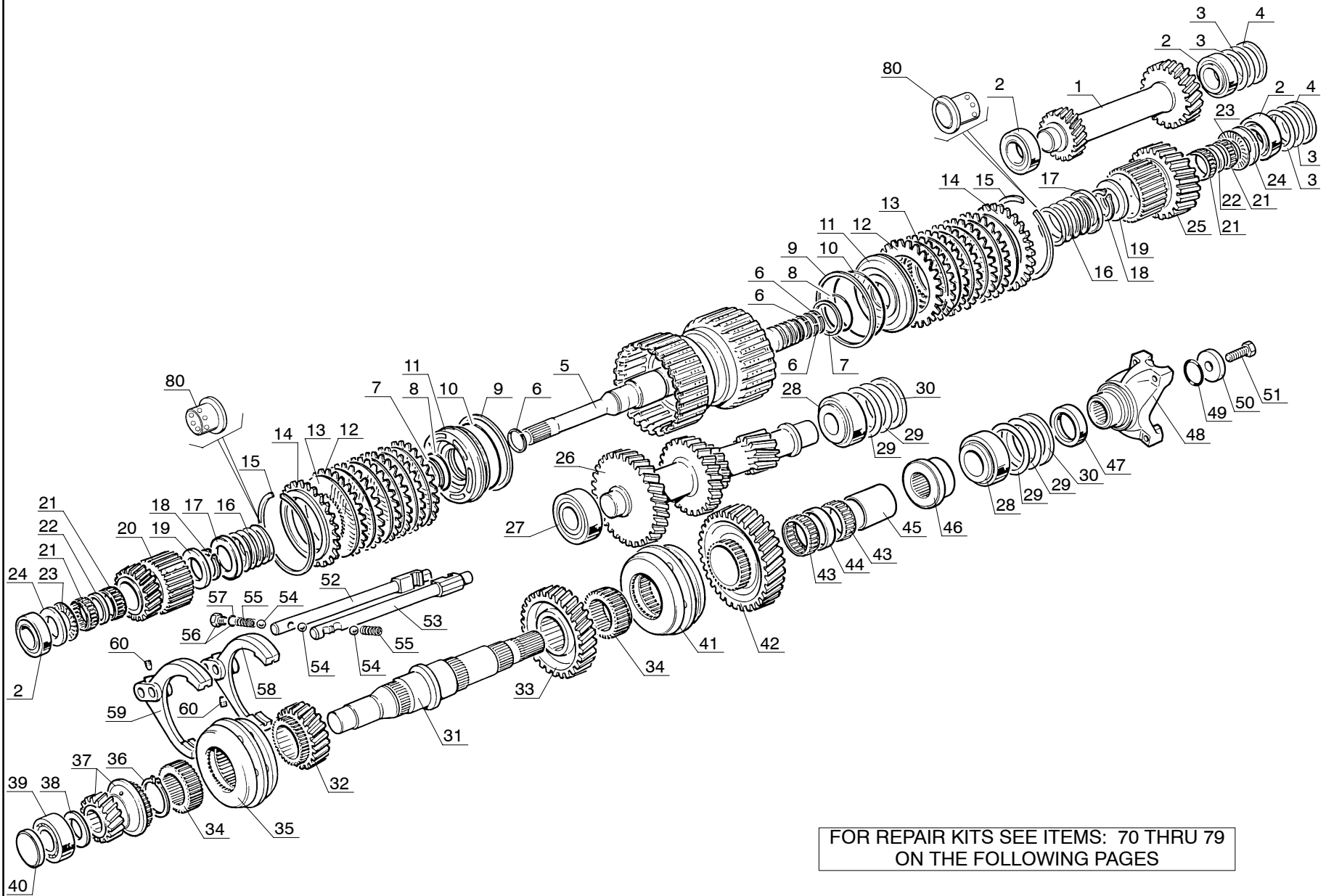

FOR REPAIR KITS SEE ITEMS: 70 THRU 79 ON THE FOLLOWING PAGES

			QUANTITY / MODEL								BP 179						
1 TRANSMISSION, 4-SPEED, 2WD, INTERNAL COMPONENTS																	
ITEM	PART NO.	DESCRIPTION	M30-2	M40-2	M50-2	M60-2	M30-2 L	M40-2 L	M50-2 L	M60-2 L							
1	561791	Reverse idler gear	1	1	1	1	1	1	1	1							
2	109701	Bearing	4	4	4	4	4	4	4	4							
3	109615	Shim .051mm (.002 in)	A/R	A/R	A/R	A/R	A/R	A/R	A/R	A/R							
3	109616	Shim .076mm (.003 in)	A/R	A/R	A/R	A/R	A/R	A/R	A/R	A/R							
3	109617	Shim .127mm (.005 in)	A/R	A/R	A/R	A/R	A/R	A/R	A/R	A/R							
3	109618	Shim .178mm (.007 in)	A/R	A/R	A/R	A/R	A/R	A/R	A/R	A/R							
3	109619	Shim .381mm (.015 in)	A/R	A/R	A/R	A/R	A/R	A/R	A/R	A/R							
3	109620	Shim .508mm (.020 in)	A/R	A/R	A/R	A/R	A/R	A/R	A/R	A/R							
4	109597	Spacer	2	2	2	2	2	2	2	2							
5	602729	Input shaft	1	1	1	1	1	1	1	1							
6	109624	Seal	4	4	4	4	4	4	4	4							
7	561805	Seal, inner	2	2	2	2	2	2	2	2							
8	561806	O-ring	2	2	2	2	2	2	2	2							
9	561803	Seal, outer	2	2	2	2	2	2	2	2							
10	561804	O-ring	2	2	2	2	2	2	2	2							
11	561802	Piston	2	2	2	2	2	2	2	2							
12	561797	Clutch disc	12	12	12	12	12	12	12	12							
13	561798	Friction disc	12	12	12	12	12	12	12	12							
14	561796	Plate	2	2	2	2	2	2	2	2							
15	561795	Circlips	2	2	2	2	2	2	2	2							
16	561801	Spring	2	2	2	2	2	2	2	2							
17	561800	Bushing	2	2	2	2	2	2	2	2							
18	561799	Circlips	2	2	2	2	2	2	2	2							
19	561789	Thrust washer	2	2	2	2	2	2	2	2							
20	561793	Forward primary gear	1	1	1	1	1	1	1	1							

2	TRANSMISSION, 4-SPEED, 2WD, INTERNAL COMPONENTS			QUANTITY / MODEL								BP 179			
				M30-2	M40-2	M50-2	M60-2	M30-2 L	M40-2 L	M50-2 L	M60-2 L				
ITEM	PART NO.	DESCRIPTION	M30-2	M40-2	M50-2	M60-2	M30-2 L	M40-2 L	M50-2 L	M60-2 L					
21	109651	Roller bearing	4	4	4	4	4	4	4	4					
22	561809	Spacer	2	2	2	2	2	2	2	2					
23	561762	Bearing	2	2	2	2	2	2	2	2					
24	561764	Stop washer	2	2	2	2	2	2	2	2					
25	561794	Backward primary gear	1	1	1	1	1	1	1	1					
26	561790	Countershaft	1	1	1	1	1	1	1	1					
27	109622	Bearing	1	1	1	1	1	1	1	1					
28	561786	Bearing	2	2	2	2	2	2	2	2					
29	109599	Shim .051mm (.002 in)	A/R	A/R	A/R	A/R	A/R	A/R	A/R	A/R					
29	109600	Shim .076mm (.003 in)	A/R	A/R	A/R	A/R	A/R	A/R	A/R	A/R					
29	109601	Shim .178mm (.007 in)	A/R	A/R	A/R	A/R	A/R	A/R	A/R	A/R					
29	109602	Shim .559mm (.022 in)	A/R	A/R	A/R	A/R	A/R	A/R	A/R	A/R					
30	109598	Spacer	2	2	2	2	2	2	2	2					
31	561785	Output shaft	1	1	1	1	1	1	1	1					
32	561775	3rd gear	1	1	1	1	1	1	1	1					
33	561776	2nd gear	1	1	1	1	1	1	1	1					
34	109586	Coupling sleeve	2	2	2	2	2	2	2	2					
35	109665	Synchro assembly	1	1	1	1	1	1	1	1					
36	109664	Circlips	1	1	1	1	1	1	1	1					
37	561774	4th gear	1	1	1	1	1	1	1	1					
38	561784	Washer	1	1	1	1	1	1	1	1					
39	561788	Bearing	1	1	1	1	1	1	1	1					
40	550632	Plug	1	1	1	1	1	1	1	1					
41	109665	Synchro assembly	1	1	1	1	1	1	1	1					
42	109568	Output shaft, 1st gear	1	1	1	1	1	1	1	1					
43	109621	Bearing	2	2	2	2	2	2	2	2					
44	109653	Spacer	1	1	1	1	1	1	1	1					
45	109652	Coupling	1	1	1	1	1	1	1	1					

			QUANTITY / MODEL								BP 179			
3 TRANSMISSION, 4-SPEED, 2WD, INTERNAL COMPONENTS														
ITEM	PART NO.	DESCRIPTION	M30-2	M40-2	M50-2	M60-2	M30-2 L	M40-2 L	M50-2 L	M60-2 L				
46	551373	Spacer	1	1	1	1	1	1	1	1				
47	109656	Seal	1	1	1	1	1	1	1	1				
48	561807	End yoke	1	1	1	1	1	1	1	1				
49	550636	O-ring	1	1	1	1	1	1	1	1				
50	109798	Washer	1	1	1	1	1	1	1	1				
51	561810	Screw	1	1	1	1	1	1	1	1				
52	561814	1st and 2nd shift rod	1	1	1	1	1	1	1	1				
53	561815	3rd and 4th shift rod	1	1	1	1	1	1	1	1				
54	109709	Ball	3	3	3	3	3	3	3	3				
55	473920	Spring	2	2	2	2	2	2	2	2				
56	550705	Plug	1	1	1	1	1	1	1	1				
57	109657	O-ring	1	1	1	1	1	1	1	1				
58	561812	1st and 2nd shift fork	1	1	1	1	1	1	1	1				
59	561813	3rd and 4th shift fork	1	1	1	1	1	1	1	1				
60	109737	Screw	2	2	2	2	2	2	2	2				
70	561932	Clutch pack kit	A/R	A/R	A/R	A/R	A/R	A/R	A/R	A/R				
71	561933	Complete clutch pack kit	A/R	A/R	A/R	A/R	A/R	A/R	A/R	A/R				
72	561934	Small parts kit	A/R	A/R	A/R	A/R	A/R	A/R	A/R	A/R				
73	562001	Bearing kit	A/R	A/R	A/R	A/R	A/R	A/R	A/R	A/R				
74	562002	Seal kit	A/R	A/R	A/R	A/R	A/R	A/R	A/R	A/R				
75	562003	Seal kit	A/R	A/R	A/R	A/R	A/R	A/R	A/R	A/R				
76	562004	Circlip kit	A/R	A/R	A/R	A/R	A/R	A/R	A/R	A/R				
77	562005	Washer kit	A/R	A/R	A/R	A/R	A/R	A/R	A/R	A/R				
78	561940	Thrust washer kit	A/R	A/R	A/R	A/R	A/R	A/R	A/R	A/R				
79	561942	Complete repair kit	A/R	A/R	A/R	A/R	A/R	A/R	A/R	A/R				
80	602730	Bushing	2	2	2	2	2	2	2	2				

BP 180

TRANSMISSION, 4-SPEED, 2WD, CONTROL VALVE

M30-2			
M40-2			
M50-2			
M60-2			
M30-2 L			
M40-2 L			
M50-2 L			
M60-2 L			

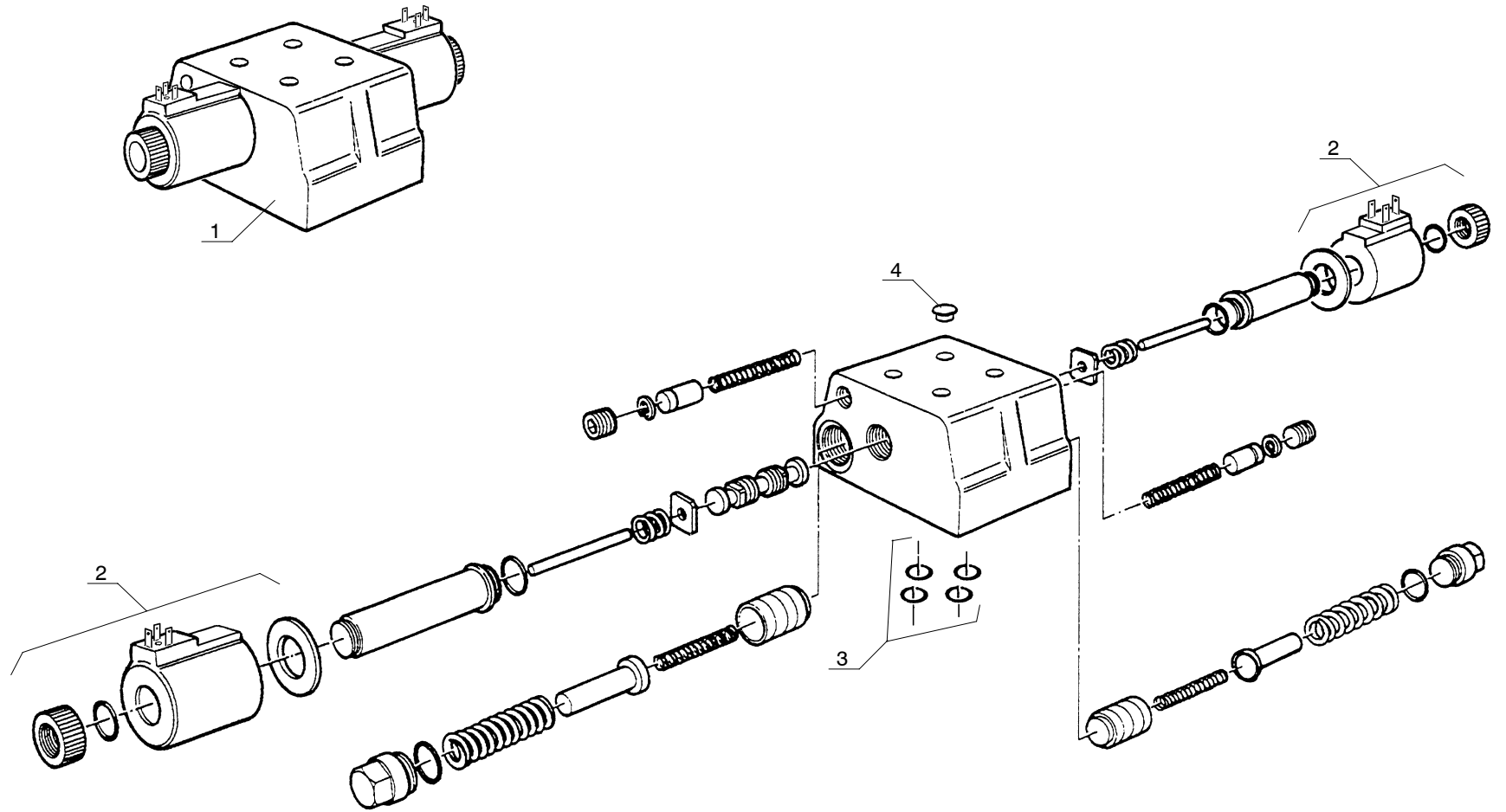

			QUANTITY / MODEL								BP 180			
1			TRANSMISSION, 4-SPEED, 2WD, CONTROL VALVE											
ITEM	PART NO.	DESCRIPTION	M30-2	M40-2	M50-2	M60-2	M30-2 L	M40-2 L	M50-2 L	M60-2 L				
1	600792	Electrical control valve	1	1	1	1	1	1	1	1				
2	561944	Solenoid	2	2	2	2	2	2	2	2				
3	561943	Seal kit	1	1	1	1	1	1	1	1				
4	562043	Plug	4	4	4	4	4	4	4	4				

107.00

BP 181

TRANSMISSION, 4-SPEED, 4WD

M30-4
M40-4
M50-4
M60-4

M30-4 L
M40-4 L
M50-4 L
M60-4 L

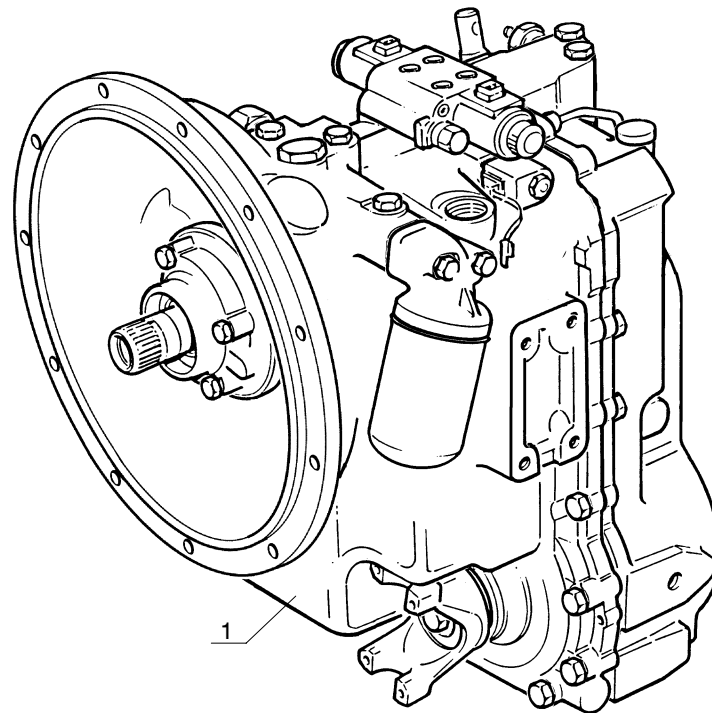

ITEM	PART NO.	DESCRIPTION	QUANTITY / MODEL								BP 181						
			M30-4	M40-4	M50-4	M60-4	M30-4 L	M40-4 L	M50-4 L	M60-4 L							
1		TRANSMISSION, 4-SPEED, 4WD															
1	222573	Gear box, complete	1	1	1	1	1	1	1	1							

108.00

M30-4
M40-4
M50-4
M60-4

M30-4 L
M40-4 L
M50-4 L
M60-4 L

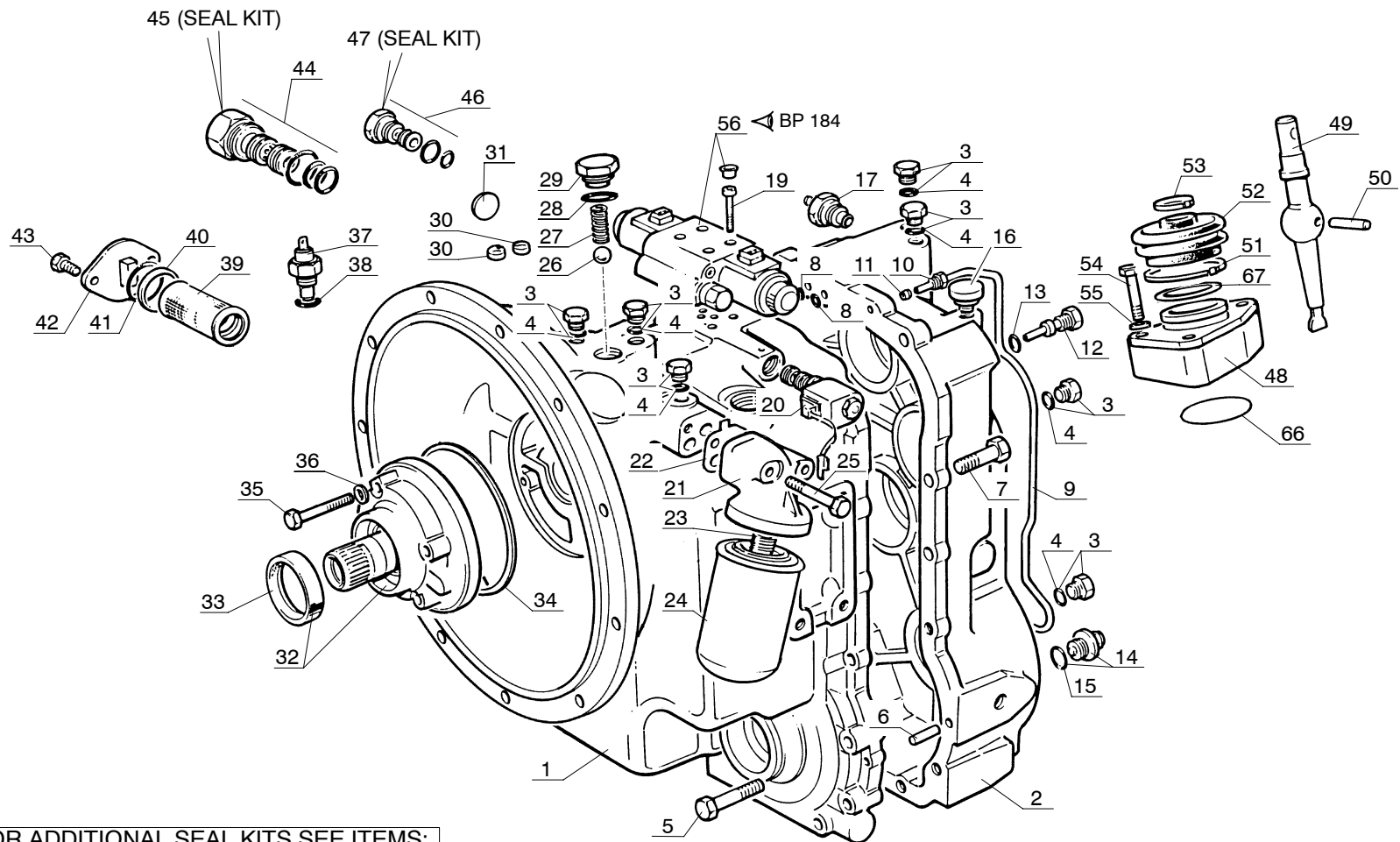

FOR ADDITIONAL SEAL KITS SEE ITEMS:
60 - 61 - 62 - 63 - 64 - 65
ON THE FOLLOWING PAGES

			QUANTITY / MODEL								BP 182						
1 TRANSMISSION, 4-SPEED, 4WD, EXTERNAL COMPONENTS			M30-4	M40-4	M50-4	M60-4	M30-4 L	M40-4 L	M50-4 L	M60-4 L							
ITEM	PART NO.	DESCRIPTION															
1	561757	Transmission housing	1	1	1	1	1	1	1	1							
2	561758	Transmission rear case	1	1	1	1	1	1	1	1							
3	550705	Plug	13	13	13	13	13	13	13	13							
4	109657	O-ring	13	13	13	13	13	13	13	13							
5	561759	Screw	4	4	4	4	4	4	4	4							
6	109703	Stud bolt	2	2	2	2	2	2	2	2							
7	109727	Screw	13	13	13	13	13	13	13	13							
8	561833	O-ring	4	4	4	4	4	4	4	4							
9	561825	Pipe	1	1	1	1	1	1	1	1							
10	561824	Nut	2	2	2	2	2	2	2	2							
11	561826	Bushing	2	2	2	2	2	2	2	2							
12	561835	Plug	1	1	1	1	1	1	1	1							
13	109657	O-ring	1	1	1	1	1	1	1	1							
14	473366	Drain plug	1	1	1	1	1	1	1	1							
15	147915	O-ring	1	1	1	1	1	1	1	1							
16	109705	Air breather	1	1	1	1	1	1	1	1							
17	549100	Oil pressure switch	1	1	1	1	1	1	1	1							
19	561829	Screw	4	4	4	4	4	4	4	4							
20	561831	Solenoid	1	1	1	1	1	1	1	1							
21	561837	Filter housing	1	1	1	1	1	1	1	1							
22	109646	Gasket	1	1	1	1	1	1	1	1							
23	109658	Connection	1	1	1	1	1	1	1	1							
24	561749	Oil filter	1	1	1	1	1	1	1	1							
25	109728	Screw	2	2	2	2	2	2	2	2							
26	561836	Ball	1	1	1	1	1	1	1	1							
27	561765	Spring	1	1	1	1	1	1	1	1							
28	561827	O-ring	1	1	1	1	1	1	1	1							

			QUANTITY / MODEL								BP 182			
			M30-4	M40-4	M50-4	M60-4	M30-4 L	M40-4 L	M50-4 L	M60-4 L				
2	TRANSMISSION, 4-SPEED, 4WD, EXTERNAL COMPONENTS													
ITEM	PART NO.	DESCRIPTION												
29	561828	Plug	1	1	1	1	1	1	1					
30	561822	Plug	2	2	2	2	2	2	2					
31	561834	Plug	1	1	1	1	1	1	1					
32	561930	Complete pump	1	1	1	1	1	1	1					
33	109690	Seal	1	1	1	1	1	1	1					
34	109676	O-ring	1	1	1	1	1	1	1					
35	561760	Screw	4	4	4	4	4	4	4					
36	109659	Washer	4	4	4	4	4	4	4					
37	552502	Oil temp sensor	1	1	1	1	1	1	1					
38	109657	O-ring	1	1	1	1	1	1	1					
39	109565	Suction strainer	1	1	1	1	1	1	1					
40	550626	Washer	1	1	1	1	1	1	1					
41	550627	O-ring	1	1	1	1	1	1	1					
42	473368	Cover	1	1	1	1	1	1	1					
43	109732	Screw	2	2	2	2	2	2	2					
44	561830	Pressure regulation valve	1	1	1	1	1	1	1					
45	561946	Seal kit	1	1	1	1	1	1	1					
46	561823	Over pressure valve	1	1	1	1	1	1	1					
47	561945	Seal kit	1	1	1	1	1	1	1					
48	562040	Upper seat	1	1	1	1	1	1	1					
49	561816	Gear lever foot	1	1	1	1	1	1	1					
50	109681	Pin	1	1	1	1	1	1	1					
51	561820	Clamp	1	1	1	1	1	1	1					
52	109612	Dust cover	1	1	1	1	1	1	1					
53	561821	Clamp	1	1	1	1	1	1	1					
54	561760	Screw	3	3	3	3	3	3	3					
55	561761	Washer	3	3	3	3	3	3	3					
56	600792	Electrical control valve	1	1	1	1	1	1	1					

3	TRANSMISSION, 4-SPEED, 4WD, EXTERNAL COMPONENTS		QUANTITY / MODEL								BP 182			
			M30-4	M40-4	M50-4	M60-4	M30-4 L	M40-4 L	M50-4 L	M60-4 L				
ITEM	PART NO.	DESCRIPTION												
60	561931	Pump kit	A/R	A/R	A/R	A/R	A/R	A/R	A/R	A/R				
61	561934	Small parts kit	A/R	A/R	A/R	A/R	A/R	A/R	A/R	A/R				
62	561936	Seal kit	A/R	A/R	A/R	A/R	A/R	A/R	A/R	A/R				
63	561937	Seal kit	A/R	A/R	A/R	A/R	A/R	A/R	A/R	A/R				
64	561941	Tube kit	A/R	A/R	A/R	A/R	A/R	A/R	A/R	A/R				
65	562148	Complete repair kit	A/R	A/R	A/R	A/R	A/R	A/R	A/R	A/R				
66	600366	O-ring	1	1	1	1	1	1	1					
67	600365	Gasket	1	1	1	1	1	1	1					

M30-4
M40-4
M50-4
M60-4

M30-4 L
M40-4 L
M50-4 L
M60-4 L

FOR REPAIR KITS SEE ITEMS: 90 THRU 99
ON THE FOLLOWING PAGES

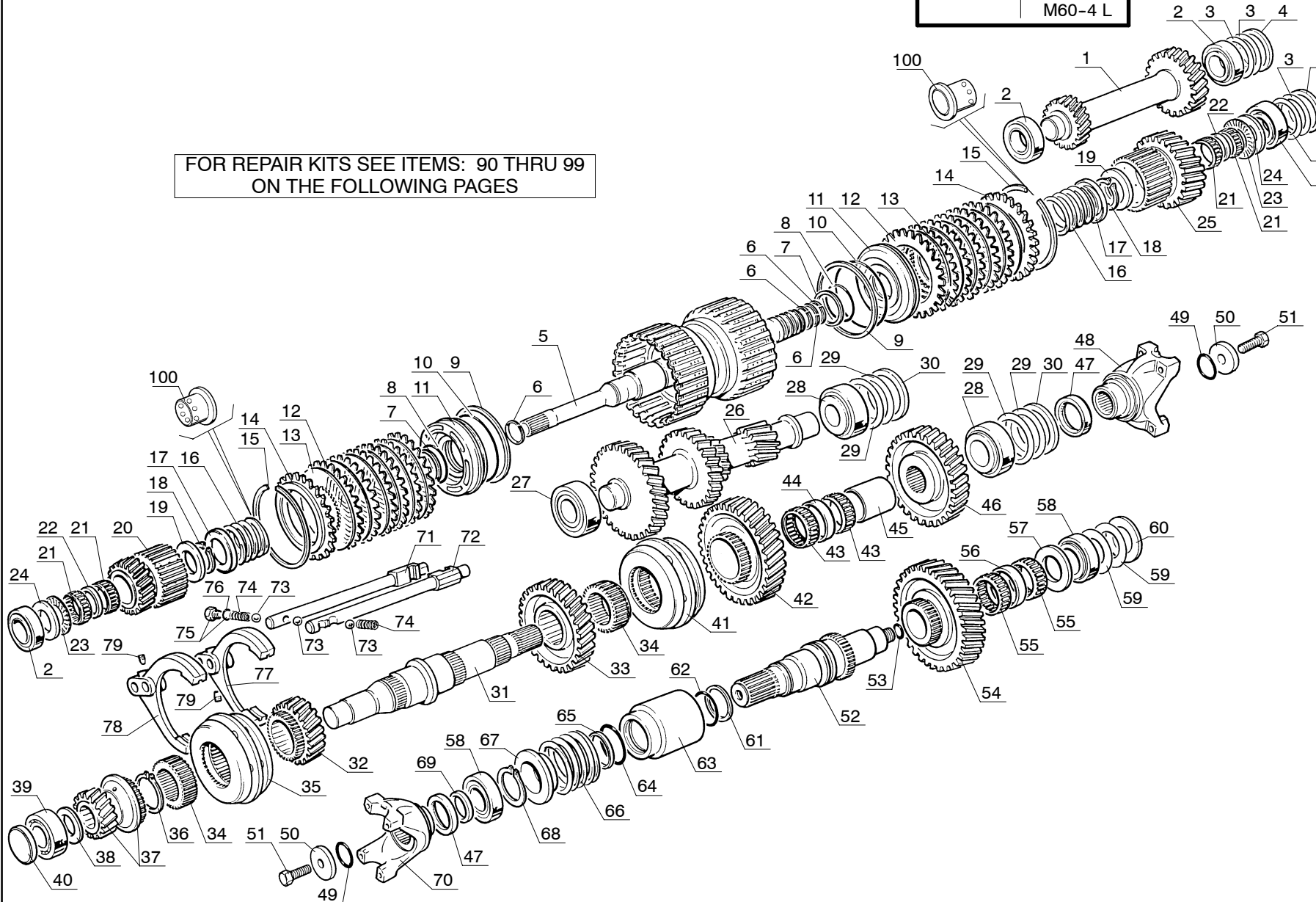

			QUANTITY / MODEL								BP 183						
1 TRANSMISSION, 4-SPEED, 4WD, INTERNAL COMPONENTS			M30-4	M40-4	M50-4	M60-4	M30-4 L	M40-4 L	M50-4 L	M60-4 L							
ITEM	PART NO.	DESCRIPTION															
1	561791	Reverse idler gear	1	1	1	1	1	1	1	1							
2	109701	Bearing	4	4	4	4	4	4	4	4							
3	109615	Shim .051mm (.002 in)	4	4	4	4	4	4	4	4							
3	109616	Shim .076mm (.003 in)	A/R	A/R	A/R	A/R	A/R	A/R	A/R	A/R							
3	109617	Shim .127mm (.005 in)	A/R	A/R	A/R	A/R	A/R	A/R	A/R	A/R							
3	109618	Shim .178mm (.007 in)	A/R	A/R	A/R	A/R	A/R	A/R	A/R	A/R							
3	109619	Shim .381mm (.015 in)	A/R	A/R	A/R	A/R	A/R	A/R	A/R	A/R							
3	109620	Shim .508mm (.020 in)	A/R	A/R	A/R	A/R	A/R	A/R	A/R	A/R							
4	109597	Spacer	2	2	2	2	2	2	2	2							
5	602729	Input shaft	1	1	1	1	1	1	1	1							
6	109624	Seal	4	4	4	4	4	4	4	4							
7	561805	Seal, inner	2	2	2	2	2	2	2	2							
8	561806	O-ring	2	2	2	2	2	2	2	2							
9	561803	Seal, outer	2	2	2	2	2	2	2	2							
10	561804	O-ring	2	2	2	2	2	2	2	2							
11	561802	Piston	2	2	2	2	2	2	2	2							
12	561797	Clutch disc	12	12	12	12	12	12	12	12							
13	561798	Friction disc	12	12	12	12	12	12	12	12							
14	561796	Plate	2	2	2	2	2	2	2	2							
15	561795	Circlips	2	2	2	2	2	2	2	2							
16	561801	Spring	2	2	2	2	2	2	2	2							
17	561800	Bushing	2	2	2	2	2	2	2	2							
18	561799	Circlips	2	2	2	2	2	2	2	2							
19	561789	Thrust washer	2	2	2	2	2	2	2	2							
20	561793	Forward primary gear	1	1	1	1	1	1	1	1							
21	109651	Roller bearing	4	4	4	4	4	4	4	4							
22	561809	Spacer	2	2	2	2	2	2	2	2							

			QUANTITY / MODEL								BP 183						
2 TRANSMISSION, 4-SPEED, 4WD, INTERNAL COMPONENTS			M30-4	M40-4	M50-4	M60-4	M30-4 L	M40-4 L	M50-4 L	M60-4 L							
ITEM	PART NO.	DESCRIPTION															
23	561762	Bearing	2	2	2	2	2	2	2	2							
24	561764	Stop washer	2	2	2	2	2	2	2	2							
25	561794	Backward primary gear	1	1	1	1	1	1	1	1							
26	561790	Countershaft	1	1	1	1	1	1	1	1							
27	109622	Bearing	1	1	1	1	1	1	1	1							
28	561786	Bearing	2	2	2	2	2	2	2	2							
29	109599	Shim .051mm (.002 in)	A/R	A/R	A/R	A/R	A/R	A/R	A/R	A/R							
29	109600	Shim .076mm (.003 in)	A/R	A/R	A/R	A/R	A/R	A/R	A/R	A/R							
29	109601	Shim .178mm (.007 in)	A/R	A/R	A/R	A/R	A/R	A/R	A/R	A/R							
29	109602	Shim .559mm (.020 in)	A/R	A/R	A/R	A/R	A/R	A/R	A/R	A/R							
30	109598	Spacer	2	2	2	2	2	2	2	2							
31	561785	Output shaft	1	1	1	1	1	1	1	1							
32	561775	3rd gear	1	1	1	1	1	1	1	1							
33	561776	2nd gear	1	1	1	1	1	1	1	1							
34	109586	Coupling sleeve	2	2	2	2	2	2	2	2							
35	109665	Synchro assembly	1	1	1	1	1	1	1	1							
36	109664	Circlips	1	1	1	1	1	1	1	1							
37	561774	4th gear	1	1	1	1	1	1	1	1							
38	561784	Washer	1	1	1	1	1	1	1	1							
39	561788	Bearing	1	1	1	1	1	1	1	1							
40	550632	Plug	1	1	1	1	1	1	1	1							
41	109665	Synchro assembly	1	1	1	1	1	1	1	1							
42	109568	Output shaft 1st gear	1	1	1	1	1	1	1	1							
43	109621	Bearing	2	2	2	2	2	2	2	2							
44	109653	Spacer	1	1	1	1	1	1	1	1							
45	109652	Coupling	1	1	1	1	1	1	1	1							

			QUANTITY / MODEL								BP 183			
			M30-4	M40-4	M50-4	M60-4	M30-4 L	M40-4 L	M50-4 L	M60-4 L				
3	TRANSMISSION, 4-SPEED, 4WD, INTERNAL COMPONENTS													
ITEM	PART NO.	DESCRIPTION												
46	561777	Output shaft drive gear	1	1	1	1	1	1	1					
47	109656	Seal	2	2	2	2	2	2	2					
48	561807	End yoke	1	1	1	1	1	1	1					
49	550636	O-ring	2	2	2	2	2	2	2					
50	109798	Washer	2	2	2	2	2	2	2					
51	561810	Screw	2	2	2	2	2	2	2					
52	561771	Output shaft	1	1	1	1	1	1	1					
53	561778	O-ring	1	1	1	1	1	1	1					
54	561772	Gear (37 teeth)	1	1	1	1	1	1	1					
55	561838	Roller bearing	2	2	2	2	2	2	2					
56	561839	Spacer	1	1	1	1	1	1	1					
57	561773	Washer	1	1	1	1	1	1	1					
58	561787	Bearing	2	2	2	2	2	2	2					
59	561780	Shim	A/R	A/R	A/R	A/R	A/R	A/R	A/R					
59	561781	Shim	A/R	A/R	A/R	A/R	A/R	A/R	A/R					
59	561782	Shim	A/R	A/R	A/R	A/R	A/R	A/R	A/R					
59	561783	Shim	A/R	A/R	A/R	A/R	A/R	A/R	A/R					
60	561779	Spacer	1	1	1	1	1	1	1					
61	561763	Seal	1	1	1	1	1	1	1					
62	561766	O-ring	1	1	1	1	1	1	1					
63	561768	Coupling	1	1	1	1	1	1	1					
64	561818	O-ring	1	1	1	1	1	1	1					
65	561819	Seal	1	1	1	1	1	1	1					
66	561769	Spring	1	1	1	1	1	1	1					
67	561770	Spring bracket	1	1	1	1	1	1	1					
68	561767	Circlips	1	1	1	1	1	1	1					
69	561808	Spacer	1	1	1	1	1	1	1					
70	561807	End yoke	1	1	1	1	1	1	1					

			QUANTITY / MODEL								BP 183			
			M30-4	M40-4	M50-4	M60-4	M30-4 L	M40-4 L	M50-4 L	M60-4 L				
4	TRANSMISSION, 4-SPEED, 4WD, INTERNAL COMPONENTS													
ITEM	PART NO.	DESCRIPTION												
71	561814	1st and 2nd shift rod	1	1	1	1	1	1	1					
72	561815	3rd and 4th shift rod	1	1	1	1	1	1	1					
73	109709	Ball	3	3	3	3	3	3	3					
74	473920	Spring	2	2	2	2	2	2	2					
75	550705	Plug	1	1	1	1	1	1	1					
76	109657	O-ring	1	1	1	1	1	1	1					
77	561812	1st and 2nd shift fork	1	1	1	1	1	1	1					
78	561813	3rd and 4th shift fork	1	1	1	1	1	1	1					
79	109737	Screw	2	2	2	2	2	2	2					
90	561932	Clutch pack kit	A/R	A/R	A/R	A/R	A/R	A/R	A/R					
91	561933	Complete clutch pack kit	A/R	A/R	A/R	A/R	A/R	A/R	A/R					
92	561934	Small parts kit	A/R	A/R	A/R	A/R	A/R	A/R	A/R					
93	561935	Bearing kit	A/R	A/R	A/R	A/R	A/R	A/R	A/R					
94	561936	Seal kit	A/R	A/R	A/R	A/R	A/R	A/R	A/R					
95	561937	Seal kit	A/R	A/R	A/R	A/R	A/R	A/R	A/R					
96	561938	Circlip kit	A/R	A/R	A/R	A/R	A/R	A/R	A/R					
97	561939	Washer kit	A/R	A/R	A/R	A/R	A/R	A/R	A/R					
98	561940	Thrust washer kit	A/R	A/R	A/R	A/R	A/R	A/R	A/R					
99	562148	Complete repair kit	A/R	A/R	A/R	A/R	A/R	A/R	A/R					
100	602730	Bushing	2	2	2	2	2	2	2					

BP 184

TRANSMISSION, 4-SPEED, 4WD, CONTROL VALVE

M30-4
M40-4
M50-4
M60-4

M30-4 L
M40-4 L
M50-4 L
M60-4 L

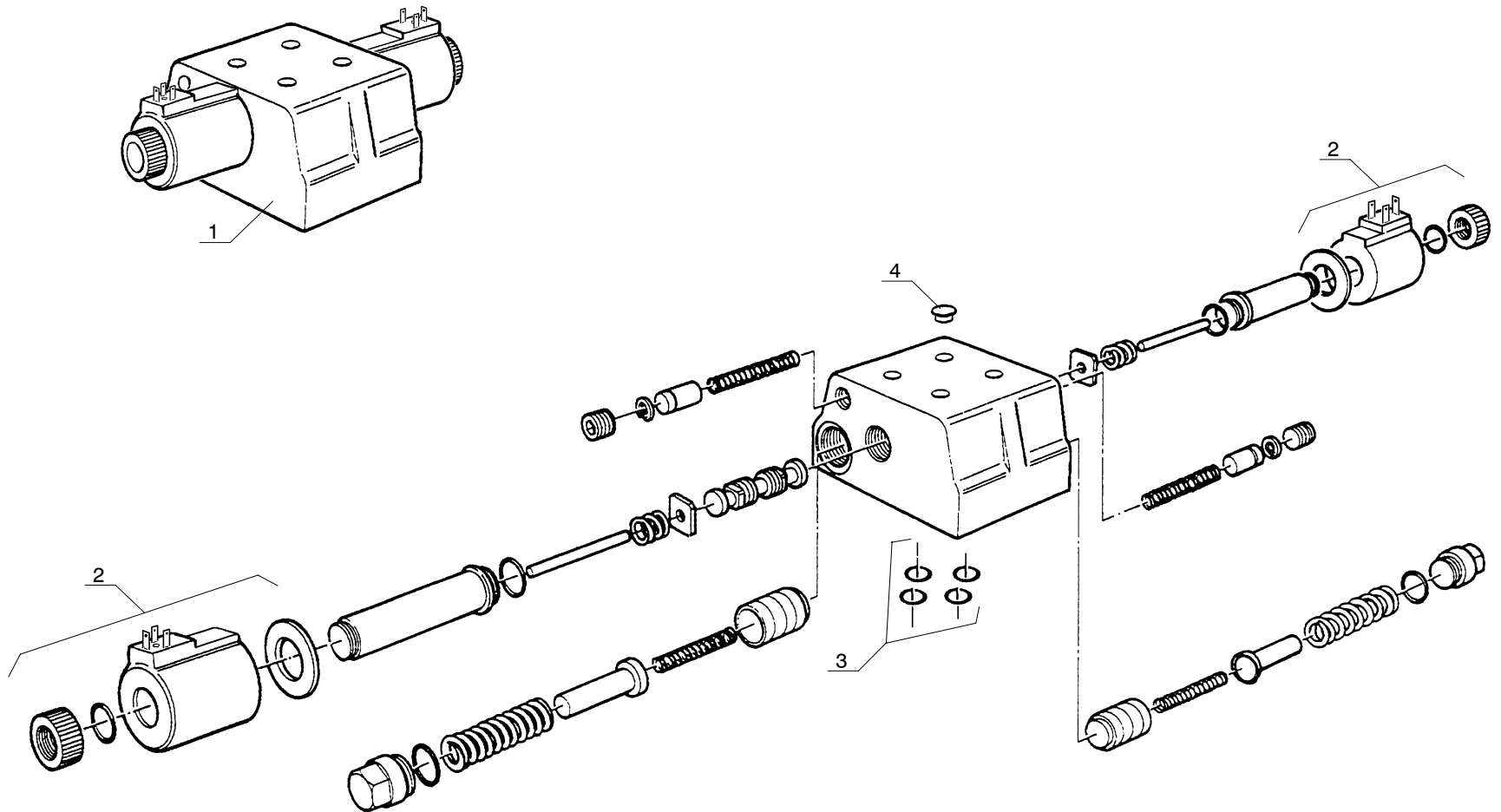

1	TRANSMISSION, 4-SPEED, 4WD, CONTROL VALVE		QUANTITY / MODEL								BP 184			
			M30-4	M40-4	M50-4	M60-4	M30-4 L	M40-4 L	M50-4 L	M60-4 L				
ITEM	PART NO.	DESCRIPTION												
1	600792	Electrical control valve	1	1	1	1	1	1	1	1				
2	561944	Solenoid	2	2	2	2	2	2	2	2				
3	561943	Seal kit	1	1	1	1	1	1	1	1				
4	562043	Plug	4	4	4	4	4	4	4	4				

111.00

PARTS INDEX: *Part no., Item no., Page (Drawing Ref. no.)*

CATALOG 802832, R03-04

105101	109615, 3, BP179-1,	16, BP 182-1	39, AX1449-2	2, 8AA101-1,	11, 11CC11-1	6, 11CC13-1
105101	BP183-1	33, 4AA50-2	133739	8AA102-1,	115, 11AA10-3,	9, 11BA30-1
6, AX1225-1	109616, 3, BP179-1,	109709	17, AP1436-1	8AA103-1	11AA20-3	189535
8, AX1418-1	BP183-1	54, BP179-3	33, AP1436-1	3, 8AA105-1,	12, 11CC12-1	3, 10AA20-1
105131, 19, AX1225-1	109617, 3, BP179-1,	73, BP183-4	133755, 2AA79-0	8AA106-1	16, 11BA20-1	4, 10AA10-1
105424, 9, AX1418-1	BP183-1	109727	2, AP1434-1	169437, 33, 7AA11-2	178696, 12, 10AF10-1	5, 4AC10-1
105491, 9, AX1225-1	109618, 3, BP179-1,	5, BP 178-1	138141, 33, 4AC11-1	169917, 14, 11BA20-1	179156	189536
106010, 2, AX1415-1	BP183-1	7, BP 182-1	138165, 6, AP1432-1	170836	33, 8AA14-2	2, 10AA20-1
106080, 8, AX1450-1	109619, 3, BP179-1,	109728	147915, 15, BP 182-1	10, 11CC09-1	48, 8AA11-2	3, 10AA10-1
106389, 5, 11CD58-1	BP183-1	20, BP 178-1	160946, 2AA79-0	4, 11BA10-1	180602, 52, 8AA12-2	4, 4AC10-1
106533	109620, 3, BP179-1,	25, BP 182-1	162229	170884, 14, AP2054-1	182038, 2, 8AA11-1,	189752
1, AX1412-1,	BP183-1	109732	1, 8AA105-1,	171912	8AA21-1	16, 8AA21-1
AX1416-1	109621, 43, BP179-2,	38, BP 178-2	8AA106-1	39, 8AA21-2	182101	17, 8AA11-1
10, AX1450-1	BP183-2	43, BP 182-2	14, TIER 2-1	70, 8AA11-3	25, 8AA21-1	189857
32, AX1418-2	109622, 27, BP179-2,	109737	22, 8AA14-1	172569, 51, 6BB10-2	30, 8AA11-1	16, 4AA51-1
106550, 4, AX1449-1,	BP183-2	60, BP179-3	24, 9AA11-1	173354, 110, 11AA20-3	182179, 4, 8AA11-1	18, 11BA40-1
AX1417-1	109624, 6, BP179-1,	79, BP183-4	34, 6BB10-2, 6BB11-1	173491	182180, 5, 8AA11-1	5, 6BA10-1, 8AA105-1,
106567, 42, AX1415-1	BP183-1	109751	8, 8AA101-1,	114, 11AA10-3,	182181, 6, 8AA11-1	8AA106-1
106842, 13, AX1225-1	109646	11, 7AB10-1	8AA102-1,	11AA20-3	183026, 10, 6BA10-1	8, 8AA104-1
107286, 22, AX1415-1	17, BP 178-1	19, 6AA30-1	8AA103-1	12, 11CC11-1	183396	190442
107293	22, BP 182-1	5, 4AB10-1	99, 11AA10-2,	13, 11CC12-1	18, 8AA14-1	27, 6BB10-1
20, AX1417-1	109651, 21, BP179-2,	6, 4AB10.2-1	11AA11-2,	17, 11BA20-1	22, 8AA21-1	31, 6BB20-2
41, AX1449-2	BP183-1	9, 6AA20-1	11AA20-2	5, 11BA40-1	23, 8AA14-1	190734
107294	109652, 45, BP179-2,	109752	162809	173717, 6, 8AA104-1	27, 8AA11-1	45, 8AA12-2
21, AX1417-2	BP183-2	10, 6AA20-1	12, 6AA20-1	174132	34, 8AA11-2	6, 8AA14-1
42, AX1449-2	109653, 44, BP179-2,	12, 7AB10-1	14, 7AB10-1	10, 4AB12-1	37, 8AA21-2	190776, 13, 8AA12-1,
107363	BP183-2	20, 6AA30-1	23, 6AA30-1	17, 8AA14-1	4, 8AA12-1, 8AA22-1	8AA22-1
12, AP2054-1	109656, 47, BP179-3,	5, 4AB10.2-1	4, 4AB10-1, 4AB10.2-1	19, 8AA21-1	48, 8AA22-2	190807, 14, 6BB11-1
15, AP1437-1	BP183-3	6, 4AB10-1	163658, 46, 12AA10-1	23, 6BA20-1	57, 8AA12-3	191022, 15, 8AA110-1
107751, 19, AX1415-1	109657	109798, 50, BP179-3,	164091, 14, 12AA10-1	24, 6BA10-1, 8AA11-1,	75, 8AA11-3	191384, 6, 11AA10-1,
107796	13, BP 182-1	BP183-3	164965	8AA14-1	184031, 79, 8AA11-3	11AA11-1,
16, AX1418-1	33, BP 178-2	109912, 7, AX1449-1,	10, 6BA20-1	25, 9AA10-1	184035	11AA20-1,
3, AX1415-1	38, BP 182-2	AX1417-1	15, 6BA10-1	30, 8AA21-1	61, 8AA11-3	11AA21-1
5, AX1420-1	4, BP 178-1, BP 182-1	128592, 2AA79-0	6, 4AA51-1	32, TIER 2-2	77, 8AA11-3	191613
108100, 7, AX1418-1	57, BP179-3	129397, 1, TIER 2-1	165919	35, 8AA11-2	184036	13, 8AA101-1
108236, 20, AP1436-1	76, BP183-4	133027, 53, AX1225-3	2, 8AA105-1,	72, 8AA11-3	31, 9AA10-1, 9AA11-1	14, 8AA102-1,
108556, 61, AX1225-3	9, 11CD58-1, BP 178-1	133044	8AA106-1	9, 10AF10-1	35, 8AA12-2	8AA103-1
109358, 10, AP1437-1	109658	13, AX1412-1	6, 8AA101-1,	174321	184130, 36, 6BB11-1	18, 8AA104-1
109480	18, BP 178-1	50, AX1418-2	8AA102-1,	3, 8AA101-1,	184526	192041, 80, 11AA10-2,
19, AX1450-1	23, BP 182-1	8, AX1416-1	8AA103-1	8AA102-1,	29, 8AA13-1	11AA11-2,
A, 3AA10-1	109659	133055, 33, AX1225-2	8AA103-1	8AA103-1	38, 8AA23-2	11AA20-2,
109565	31, BP 178-2	133069	4, 8AA105-1,	4, 8AA105-1,	5, 11CC11-1	11AA21-2
34, BP 178-2	36, BP 182-2	16, AX1417-1	58, 8AA22-2	8AA106-1	184642, 10, 6AA10-1	192093, 7, 10AE10-1
39, BP 182-2	109664, 36, BP179-2,	33, AX1449-2	68, 8AA12-3	174677	184817, 7, 11AA10-1,	192310, 7, 11BA20-1
109568, 42, BP179-2,	BP183-2	133088, 8, AX1415-1	166702	10, 8AA12-1	11AA11-1,	192415, 12, 11BA40-1
BP183-2	109665	133090, 1, AX1418-1	16, 8AA13-1	51, 8AA22-2	11AA20-1,	192871, 18, 10DA88-1
109586, 34, BP179-2,	35, BP179-2, BP183-2	133103	36, 8AA23-2	60, 8AA12-3	11AA21-1	193161, 59, 8AA11-3
BP183-2	41, BP179-2, BP183-2	17, AX1418-1	167775, 57, 8AA11-3	175498	184818, 31, 8AA14-2	194661
109597, 4, BP179-1,	109676	4, AX1420-1	168348, 73, 11AA10-2,	26, 6BB10-1	185054, 4, 8AA100-1	6, 8AA13-1
BP183-1	29, BP 178-1	133118, 20, AX1225-1	11AA11-2,	30, 6BB20-2	185068, 64, 4AB11-1	8, 8AA23-1
109598, 30, BP179-2,	34, BP 182-2	133131, 34A, AX1225-2	11AA20-2,	175743	185580, 37, 6BB11-1	194668
BP183-2	109681	133136, 5, AX1225-1	11AA21-2	26, 10DA88-1	187283, 2, 4AC10-1	14, 8AA23-1
109599, 29, BP179-2,	45, BP 178-2	133138, 5, AX1225-1	11AA11-2,	27, 10AA20-1	187294, 6, 4AC10-1	23, 8AA13-1
BP183-2	50, BP 182-2	133173, 37, AX1449-2	11AA11-1,	31, 10AE10-2	187485, 3, 4AC10-1	194673
109600, 29, BP179-2,	109690	133177, 25A, AX1225-2	4AB10.2-1	176737, 24, 11AA10-1,	187898, 8, 10CE15-1	23, 8AA21-1
BP183-2	28, BP 178-1	133186, 6, AX1449-1,	3, 8AA112-1	11AA11-1,	189172	28, 8AA11-1
109601, 29, BP179-2,	33, BP 182-2	AX1417-1	168354, 8, 8AA10-1,	11AA20-1,	1, 8AA30-1	3, 8AA12-1, 8AA22-1
BP183-2	109701, 2, BP179-1,	133187, 35, AX1225-2	8AA20-1	11AA21-1	15, 4AA51-1	36, 8AA21-2
109602, 29, BP179-2,	BP183-1	133199, 12, AX1415-1	168379, 11, 6AA10-1	176864, 6, 10AA10-1	9, 8AA40-1	42, 8AA12-2, 8AA22-2
BP183-2	109703, 6, BP 178-1, BP	133276, 56, AX1225-3	168494, 63, 10AE10-3	177082, 7, 8AA104-1	10, 8AA50-1	43, 8AA11-2
109612	182-1	133296, 27, AX1225-2	168706, 8, 4AB12-1	177274, 22, 10AE10-1	3, 11CC14-1	47, 8AA22-2
47, BP 178-2	109705	133570	168758, 64, 10AE10-3	177738, 3B, 11BA10-1	4, 6BB10-1, 8AA10-1,	56, 8AA12-3
52, BP 182-2	12, BP 178-1	19, AX1417-1	168870	177739	8AA20-1	74, 8AA11-3

PARTS INDEX: Part no., Item no., Page (Drawing Ref. no.)

CATALOG 802832, R03-04

195069	27, 8AA23-1	1, 8AA101-1,	48, 4AB11-1	21, 6BB20-1	13, 11CC09-1	234267, 49, 4AB11-1
17, 8AA102-1,	199978	8AA102-1	209113, 3, 8AA100-1	29, 6BB10-2	224774	234292
8AA103-1	19, 8AA14-1	19, 8AA104-1	209115, 9, 9AA10-1	220222, 6, 11BA10-1	108, 11AA10-3,	11, 10AA40-1
17, 8AA101-1	21, 8AA14-1	2, 8AA103-1	209131	220370, 42, 6BB10-2	11AA11-3,	5, 10AA20-1
195535, 23, 8AA12-1,	200316	8, 8AA105-1,	2, 10DA88-1	220435, 133, 11AA10-3,	11AA20-3,	234798, 6, 12AA10-1
8AA22-1	1, 10CE15-1	8AA106-1	4, 10AE10-1	11AA11-3,	11AA21-3	234799, 8, 12AA10-1
196821	7, 7AA11-1	203123, 1, 8AA104-1	209372, 15, 4AA50-1	11AA20-3,	12, 11CC09-1	234802, 5, 12AA10-1
19, 8AA16-1	200317, 20, 7AA11-1	203124, 2, 8AA104-1	209373, 17, 4AA50-1	11AA21-3	224775, 14, 11CC09-1	234804, 39, 12AA10-1
9, 11AB10-1	200944, 31, BC139-2	203125	209374, 16, 4AA50-1	220645	224776, 13, 4AA10-1	234956, 50, 11AA10-1,
196905, 130, 11AA10-3,	201008, 12, 8AA12-1,	3, 8AA104-1	209375, 19, 4AA50-1	11, 6BA20-1	224826, 5, 6AA32-1	11AA11-1,
11AA11-3,	8AA22-1	9, 8AA105-1,	209376, 18, 4AA50-1	13, 6BA10-1	224861, 40, 6BB11-1	11AA20-2,
11AA20-3,	201149, 4, BC139-1	8AA106-1	209573, 20, 4AA50-1	221172	225199	11AA21-2
11AA21-3	201197, 32, BC139-2	203126	210005, 7, 8AA100-1	44, 10AA40-1	1, 6BA54-1	235171, 7, 6BA10-1
196951	201198	10, 8AA105-1,	210006, 2, 8AA100-1	7, 10AA10-1	35, 6BA10-2	236096, 45, 6BB11-1
10, 8AA104-1	23, BC139-1	8AA106-1	210792	221174, 2AA79-0	226148	237802
111, 11AA11-3,	9, BC139-1	4, 8AA104-1	26, 6BA10-1	38, 10AA40-1	1, 4AB10-1, 4AB10.2-1	20, 6BA20-1
11AA21-3	201199, 26, BC139-1	203127	6, 6BA20-1	221233	65B, AX1225-3	6, 6BA10-1
15, 6BB21-1, 8AA14-1	20125, 9, 11AA10-1,	11, 8AA105-1,	210845, 24, TIER 2-2	35, 8AA21-2	78B, 4AB11-2	237806
4, 6BA10-1	11AA11-1,	8AA106-1	210942, 3, 11AA10-1,	47, 8AA11-2	226256, 2, 6BA10-1	28, 6BB10-1
6, 8AA105-1,	11AA20-1,	5, 8AA104-1	11AA11-1,	221391, 61, 11AA10-2,	226426, 11, 4AA30-1	32, 6BB20-2
8AA106-1	11AA21-1	203452, 2, 8AA14-1	11AA20-1,	11AA20-2	226430, 6, AP2054-1	238065
9, 8AA101-1	201563, 2, 8AA104-1	203512, 29, 4AB10-2	11AA21-1	222572	226807, 5, 4AA10-1	56, 11AA10-2,
197335, 16, 10BA10-1	201849, 5, TIER 2-1	203515, 21, 7AA11-1	211278, 7, 4AA51-1	1, BP177-1	226921, 2, 4AA10-1	11AA11-2
197468	201931, 4, 8AA14-1	203516, 25, 7AA11-1	212847, 16, 10AE10-1	14, 4AA50-1	227076, 3, 4AA10-1	6, 11CC09-1
50, 8AA22-2	201935, 64, 8AA12-3	203517, 25, 7AA11-1	213400, 4AB10.5-0	222573	227128	238216
59, 8AA12-3	202144	203518, 25, 7AA11-1	25, 10AA20-1	1, BP181-1	15, 4AB10-1,	1, AX2520-1
197469	16, 6BB21-1,	203524, 23, 7AA11-1	59, 4AB11-1	11, 4AA50-1	4AB10.2-1	3A, 7AB10-1
52, 8AA22-2	8AA102-1	204069, 11, TIER 2-1	214516, 1A, 11AA10-1,	223246, 40, 11AA10-1,	3, 4AA40-1	238351, 1A, 8AA10-1
62, 8AA12-3	3, 8AA121-1	204220, 34, 10AE10-2	11AA20-1	11AA11-1	4, 4AA50-1	240077, 2, 10AF10-1
197471	4, 8AA13-1	205250, 48, 8AA12-2	214517, 2, 11AA10-1,	223480, 1B, 11BA10-1	229433, 8, 7AA11-1	240897, 1A, AP2054-1
53, 8AA22-2	6, 8AA23-1	205257, 54, 8AA11-2	11AA20-1	223481	229587, 1, 4AA10-1	241607, 42, 9AA11-1
61, 8AA12-3	202223, 53, 4AB11-1	205275	215875, 51, 11AA10-1,	12, 6BA20-1	230337, 23, AP2054-1	243197
197670, 4, 10CE15-1	202226	15, 8AA23-1	11AA11-1,	27, 6BA10-1	231199, 3, 11CD58-1	1, 6BA10-1
197709, 12, 10CE15-1	22, 10DA88-1	17, 8AA13-1	11AA20-2,	223902, 7, 9AA10-1	231243, 8, 11AA10-1,	3, 6BA20-1
198059	45, 10AE10-2	20, 8AA21-1,	11AA21-2	223903, 29, 9AA10-1	11AA11-1,	243482, 27, TIER 2-2
1, 8AA16-1	202244, 55, 4AB11-1	8AA104-1	216000, 14, 8AA101-1	223904, 11, 9AA10-1	11AA20-1,	243798
12, 11AB10-1	202286, 54, 4AB11-1	25, 8AA11-1	2163, 13, 11BA20-1	224345, 7, 9AA11-1	11AA21-1	1, 6BA20-1
2, 8AA16-1	202418, 8, 8AA22-1	27, 9AA10-1	216355, 9, 8AA10-1,	4, 4AA10-1	231244	3, 6BA10-1
198060	202703, 33, 11AA10-1,	29, 8AA21-1	8AA20-1	224712, 15, 4AA10-1	11, 6AA32-1	244242, 18, 11CD31-1
18, 8AA16-1	11AA11-1,	41, 8AA12-2, 8AA22-2	217050, 60, 4AB11-1	224713, 2AA79-0	128, 11AA20-3,	244289, 21, 11CD31-1
7, 11AB10-1	11AA20-1,	44, 8AA11-2	217947	224759, 11, 11BA40-1	11AA21-3	244726, 33, TIER 2-2
198290	11AA21-1	73, 8AA11-3	10, 6BB10-1	224763, 36, 11AA10-1,	16, 11BA30-1	245772, 1B, 8AA10-1
11, 8AA21-1	202731	205785, 23, 4AA50-1	33, 6BB20-2	11AA11-1	231403, 16, 11BA40-1	245776, 1, 8AA20-1
19, 8AA11-1	10, 8AA102-1,	205805, 15, 11BA20-1	218013, 35, 6BB11-1	224765	231464	246073, 6, 7AA10-1
199728	8AA103-1,	205933, 11, 8AA104-1	218074, 11, 6BB10-1	11, 11CC12-1	126, 11AA20-3,	246347, 34, 4AA50-2
24, 10DA88-1	8AA120-1	206082, 77, 11AA10-2,	218075, 24, 6BB10-1	3, 11CC09-1	11AA21-3	24653, 41, 12AA10-1
40, 10AE10-2	13, 8AA14-1	11AA20-2	218083, 13, 8AA104-1	5, 11CC09-1	9, 11CC09-1	803667, 40, 12AA10-1
199955	14, 8AA40-1	206271, 3, 8AA11-1,	218177, 3, 6AA10-1	8, 11CC11-1	231486	246700, 44, 11AA10-1,
14, 8AA21-1	15, 8AA50-1	8AA21-1	218178, 4, 6AA10-1	224766	14, 11AB10-1	11AA20-1
22, 8AA11-1	22, 9AA11-1	206698, 2, 7AA11-1	218179, 5, 6AA10-1	1, 11CC09-1	2, 11CC09-1	247331, 13, TIER 2-1
199956	4, 11BA20-1	207007	218180, 6, 6AA10-1	10, 11CC12-1	232998, 27, 4AA50-1	247475, A, TIER 2-1
13, 8AA21-1	6, 8AA122-1,	1A, 11CD10-1	218258, 22, 10AA30-1	7, 11CC11-1	233341, 3, 11BA40-1	247594, 8, TIER 2-1
21, 8AA11-1	11BA30-1	113, 11AA10-3,	218852	224767	233353	247818, 2, TIER 2-1
199961	7, 8AA105-1	11AA20-3	33, 8AA21-2	25, 11BA20-1	12, 6BA10-1	247819, 3, TIER 2-1
1, 8AA14-1	202731, 15, 8AA30-1	18, 11BA20-1	80, 8AA11-3	4, 11CC09-1	19, 6BA20-1	25713
6, 8AA15-1	202947, 6, 8AA100-1	207783, 5, 8AA100-1	219100, 47, 11AA10-1,	224768	233837	12, 8AA105-1,
199963	202953, 4, 8AA101-1,	207784, 15, 10BA10-1	11AA11-1	15, 11BA40-1	28, 6BB10-1	8AA106-1
3, 8AA14-1	8AA102-1,	207785, 14, 10BA10-1	219180, 8, 6BA10-1	7, 11CC09-1	22, 6BB20-1	17, 11BA40-1
7, 8AA15-1	8AA103-1	208561	219432, 24, 4AA50-1	224773	233870	22, 6BA10-1
199976	202954, 5, 8AA101-1,	61, 4AB11-1	219464, 22, 4AA50-1	109, 11AA10-3,	127, 11AA20-3,	24, 6BA20-1
13, 8AA23-1	8AA102-1,	71, 4AB11-1	219518, 12, 6AA10-1	11AA11-3,	11AA21-3	38, 6BB11-1
14, 8AA13-1	8AA103-1	208701	219533, 9, 11BA20-1	11AA20-3,	8, 11CC09-1	4, 11CC09-1
25, 8AA13-1, 8AA23-1	203115	1, BC108-1	219559	11AA21-3	234196, 4AA20-1	57, 8AA22-2

PARTS INDEX: Part no., Item no., Page (Drawing Ref. no.)

CATALOG 802832, R03-04

67, 8AA12-3	22, 6BA20-1	421309, 52, 7AA11-2	42325	13, 7AB10-1	426688	474054, 7, AP1434-1
8, 10AF10-1	23, 6BA10-1	421310, 54, 7AA11-2	10, 4AA31-1	22, 6AA30-1	2, 7AA10-1	474060, 10, AP2054-1
25714	26, 8AA12-1, 8AA22-1	421311, 53, 7AA11-2	11, 4AC11-1	7, 4AB10-1, 4AB10.2-1	8, 7AB10-1	474064
10, 10AF10-1	29, 11CD30-1	421313, 47, 7AA11-2	12, 8AA14-1	424764, 2AA79-0	42818, 26, 4AB10-2,	32, AP1436-1
11, 11BA30-1	3, 8AA30-1	421314, 49, 7AA11-2	14, 10AA10-1	10, 10AA10-1	4AB10.2-2	8, AP1437-1
11, 8AA40-1	30, TIER 2-2	421315, 56, 7AA11-2	15, 8AA101-1	9, 10AA20-1	44026, 21, 9AA10-1,	474075, 11, AP1435-1
12, 8AA50-1	33, 6BB10-2, 6BB11-1	421318, 12, 7AA11-1	16, 8AA104-1	424890, 53, 10AE10-2	9AA11-1	474124, 11, AP1432-1
14, 8AA30-1	4, 11CC14-1	421481, 7, 6BB21-1	17, 10AE10-1	424947, 14, 6BB21-1	44672	474298
15, 9AA10-1, 9AA11-1	43, 8AA14-2	421520, 17, 7AA11-1	18, 6BB21-1	425023, 45, 11AA10-1,	15, 6BA20-1	17, AX1417-1
18, 6AA32-1	5, 11CC13-1	421538, 50, 7AA11-2	23, 4AB12-1	11AA11-1	30, 6BA10-2	34, AX1449-2
19, 11BA40-1	7, 8AA101-1	42231	27, 7AA11-2,	425316, 10, 6BB21-1	447847, 12, AX1418-1	474300
21, 8AA12-1, 8AA22-1	8AA102-1,	10, 4AA10-1	AP2054-1	425330	44807, 28, 4AA50-1	17, AX1417-1
22, 11BA20-1	8AA103-1	13, 4AB10-1,	3, 6BB10-1	2, 6AA20-1	448834, 15, 6AA32-1	34, AX1449-2
25, 6BA10-1, 6BA20-1,	29475	4AB10.2-1,	4, 8AA23-1, 8AA40-1,	21, 6AA30-1	458502, 10, BC139-1	474312, 45A, AX1418-2
8AA12-1,	2, 4AA51-1	4AB11-1	8AA50-1	3, 4AB10-1, 4AB10.2-1	46668	474313, 46, AX1418-2
8AA22-1	6, 4AA50-1	14, 4AA31-1	41, 8AA21-2	5, 7AB10-1	27, 8AA12-1, 8AA22-1	474783, 24, BC139-1
29, TIER 2-2	67, 4AB11-1	2, 4AA50-1, 6AA11-1	46, 8AA12-2	425340, 12, 6BB21-1	28, TIER 2-2	474948, 2AA79-0
5, 11CC14-1	9, 4AA10-1	3, 4AA51-1	49, 6BB10-2	496653, 45, 12AA10-1	473079	15A, AP2054-1
55, 8AA22-2	29483	30, 10AE10-2	5, 8AA14-1, 11BA20-1	425394, 29, 10AA30-2	118, 11AA10-3,	3, AP1437-1
6, 11CC09-1	15, 8AA12-1, 8AA16-1,	7, 4AA40-1, 4AB12-1	53, 8AA11-2	425481	11AA11-3,	496816, 2AA79-0
65, 8AA12-3	8AA22-1	42232	7, 4AA20-1, 8AA122-1,	14, 11CD31-1	11AA20-3,	475059
7, 11CC13-1	53, 8AA12-2	10, 8AA112-1	11BA30-1	7, 11CD30-1	11AA21-3	14, AX1225-1
9, 4AB12-1	30327	11, 8AA111-1,	8, 8AA110-1	425493	3A, 11BA10-1	5, AX1415-1
25758	10, 8AA101-1	8AA122-1	9, 8AA13-1, 8AA22-1,	24, 11CD30-1	473366	475201, 27, AP1435-1
17, 6AA32-1	11, 8AA102-1,	11B, 4AC11-1	8AA111-1,	5, 11CD31-1	10, BP 178-1	475202
21, 6BA10-1	8AA103-1	11, 8AA101-1	8AA120-1	425494	14, BP 182-1	3, AP1434-1
28959	31007, 8, 6AA32-1	12, 4AA30-1,	90, 11AA10-2,	2, 11CD31-1	473368	6, AP1434-1
10, 11AB10-1	31051, 12, TIER 2-1	8AA102-1,	11AA11-2,	5, 11CD30-1	37, BP 178-2	475205, 5, AP1434-1
13, 6AA32-1	31089	8AA103-1	11AA20-2,	425495	42, BP 182-2	475260
14, 11BA30-1	3B, 10AA30-1	14, 8AA105-1,	11AA21-2	1, 11CD31-1	473396, 2, AP1430-1	38, AX1418-2
41, 8AA14-2	52, 10AE10-2	8AA106-1,	423309, 12, 11CC14-1	4, 11CD30-1	473399, 5, AP1430-1	C, 3AA20-1
84, 11AA10-2,	3212	9AA10-1	423397, 21, 12AA10-1	425497, 4, 10AA20-1	473400, 6, AP1430-1	475374, 29, 4AC11-1
11AA11-2,	10, 6BB20-1	15, 8AA104-1,	423398, 7, 12AA10-1	425501, 2AA79-0	473401, 3, AP1430-1	476018
11AA20-2,	19, 9AA10-1	8AA120-1	42347	12A, 4AC10-1	473404, 7, AP1430-1	16, AP1436-1
11AA21-2	7, 6BB10-1	2, 4AA20-1	10A, 4AC11-1	19, 10AA20-1	473575, 30, AX1418-2	31, AP1436-1
28987	32963, 13, 6AA10-1	22, 4AB10-1,	16, 8AA110-1	20, 10AA10-1	473816, 5, AP1435-1	476074, 25, AP1435-1
20, 6BA10-1	33593, 29, 4AB10.2-2	4AB10.2-1,	16, 8AA101-1	425514, 1, 11CC13-1	473907, 8, AP1430-1	476318, 5, 10DA88-1
7, 6BA20-1, 11CD10-1	3411, 4, TIER 2-1	4AB11-1	17, 8AA104-1	425520, 10, 11CD30-1	473915, 11, BP 178-1	476321, 6, 10DA88-1
9, 11BA40-1	36010, 4, 4AA30-1	7, 11BA40-1	28, AP2054-1	425523, 12, 11CD30-1	473920	476322, 9, 10DA88-1
29437	401831, 11, BC139-1	9, 6BA20-1, 10AE10-1	47, 6BB10-2	425674, 18, 7AA11-1	55, BP179-3	476324, 10, 10DA88-1
10, 8AA122-1	4039, 29, 4AA50-2	42256, 9, 4AB10-1,	5, 10AA10-1	426041, 6, 7AA11-1	74, BP183-4	476325, 11, 10DA88-1
11, 11CD31-1	406017	4AB10.2-1	6, 4AA10-1	426042, 16B, 7AA11-1	473939, 13, AP2054-1	476341, 8, 10DA88-1
12, 8AA110-1	23, 6BB20-1	422647, 6, 4AC11-1	7, 8AA111-1	426131, 22, 7AA11-1	473951, 9, AP1437-1	476850
12B, 4AC11-1	9, 6BB10-1	42316	71, 11AA10-2,	426196, 40, 4AA10-1	473955, 31, 4AC11-1	13, 10DA88-1
13, 9AA10-1	409248, 12, BC139-1	10, 11BA30-1	11AA11-2,	426197, 39, 4AA10-1	473956	14, 10DA88-1
16, 8AA120-1	41077, 41, 11AA10-1,	11, 10AF10-1	11AA20-2	426198, 41, 4AA10-1	19, AP2054-1	15, 10DA88-1
3, 8AA111-1	11AA11-1,	17, 6BB21-1, 9AA11-1	9, 4AA20-1, 4AA31-1	426203, 37, 4AA10-1	5, AP1437-1	477473
32, 6BA10-2	11AA20-1,	20, 8AA12-1, 8AA22-1	423625, 6, 4AA20-1, TIER	426206, 35, 4AA10-1	7, AP2054-1	22, AX1449-1
4, 8AA112-1	11AA21-1	21, 11BA20-1	2-1	426210, 69, 10AE10-3	473969, 9, AP1430-1	57, AX1225-3
6, 8AA10-1, 8AA20-1,	420431, 76, 4AB11-2	28, 8AA22-1	4240	426642, 44, 12AA10-1	473986, 30, AP1436-1	477474, 50, AX1225-3
10AA20-1	420732, 4, 12AA10-1	31, TIER 2-2	16, 8AA16-1	426648	474005, 7, AP1435-1	477475, 29, AX1225-2
8, 10AA10-1,	420772, 9, 12AA10-1	34, 8AA14-2	8, 11AB10-1	1, 6AA31-1	474011	477476, 30, AX1225-2
10AE10-1	420774, 10, 12AA10-1	43, 8AA12-2, 8AA22-2	42412	6, 6AA20-1	19, 10AE10-1	477538, 2, AX1420-1
29441, 18, 8AA12-1,	420792, 12, 12AA10-1	5, 11CC09-1	5, 8AA13-1	426649	7, AP1437-1	477693, 27, AX1449-1
8AA22-1, 9AA11-1	421116	56, 8AA22-2	7, 8AA23-1	4, 6AA30-1	474020, 4, AP1434-1	477964, 1, AX1420-1
29469	30, 7AA11-2	66, 8AA12-3	424186, 30, 9AA11-1	6, 6AA31-1	474031	478022, 5, AX1225-1
10, 8AA40-1	57, 7AA11-2	7, 6AA32-1	424282	7, 6AA20-1	12, AP1437-1	478054, 5, AP1432-1
11, 8AA50-1	B, 3AA20-1	42322	13, 11CD31-1	3, 7AA10-1	14, AP1436-1	478547, 16, 6AA32-1
13, 8AA105-1,	421206, 2AA79-0	10, 4AA40-1	3, 11CD30-1	426650	474032, 6, AP1435-1	479218
8AA106-1	421304, 55, 7AA11-2	14, 7AA11-1	424359, 2, 11CC13-1	3, 7AA10-1	474036, 17, AP1437-1	21, 6BB10-1
16, TIER 2-1	421305, 46, 7AA11-2	28, 4AB10-2,	424443, 3, 11CC13-1	5, 6AA20-1, 6AA30-1,	474037, 19, AP1437-1	6, 6BB20-1
19, 8AA12-1, 8AA22-1	421306, 48, 7AA11-2	4AB10.2-2	424647	6AA31-1	474038, 18, AP1437-1	9, 4AC11-1
21, 8AA104-1	421307, 51, 7AA11-2	9, 4AA50-1	11, 6AA20-1	9, 7AB10-1	474049, 1, AP1434-1	47927, 13, 10BA10-1

PARTS INDEX: Part no., Item no., Page (Drawing Ref. no.)

CATALOG 802832, R03-04

480079, 17, 10AF10-1	508802, 32, 4AB10-2,	3, 11CD10-1	12, 8AA23-1	552640, 5, AP2054-1	561520	561771, 52, BP183-3
48384, 36, 10AAA40-1	4AB10.2-2	70, 11AA10-2,	13, 8AA13-1	552670	24, 8AA21-1	561772, 54, BP183-3
487961, 2, 11BA10-1	514278	11AA11-2,	26, 8AA13-1, 8AA23-1	18, 8AA21-1	29, 8AA11-1	561773, 57, BP183-3
487962, 4, 11BA40-1	14, 6BA10-1	11AA20-2,	28, 8AA23-1	23, 8AA11-1	561521	561774, 37, BP179-2,
488236	16, 6BA20-1	11AA21-2	551615	552672	27, 8AA21-1	BP183-2
11, 10AA10-1	514279	549672, 17, 10DA88-1	17, AX1417-1	34, 8AA21-2	32, 8AA11-2	561775, 32, BP179-2,
8, 10AA20-1	26, 6BA20-1	549774, 16, 10DA88-1	34, AX1449-2	50, 8AA11-2	561524, 2, 8AA12-1,	BP183-2
491714, 6, 11CC12-1	33, 6BA10-2	550153, 5, 8AA15-1	551616	552682, 3, 8AA15-1	8AA22-1	561776, 33, BP179-2,
491718, 1, 11CC12-1	5239, 7, 10CE15-1	550493, 3, AP1432-1	2, AX1417-1	552709, 62, 8AA11-3	561525, 7, 8AA22-1	BP183-2
491746, 1, 8AA110-1,	524789, 56, 4AB11-1	550499, 8, AP1432-1	38, AX1449-2	552760	561526, 16, 8AA12-1,	561777, 46, BP183-3
8AA112-1	525434, 52, 4AB11-1	550520, 68, 10AE10-3	551658, 11, AP2054-1	3, 8AA13-1	8AA22-1	561778, 53, BP183-3
491779, 26, 12AA10-1	525436, 62, 4AB11-1	550556	551662	37, 8AA23-2	561527	561779, 60, BP183-3
491913, 11, 11CC14-1	525829, 32, 10AA30-2	2, AX1417-1	11, AP1437-1	4, 11CC11-1	28, 8AA12-2	561780, 59, BP183-3
49330, 8, 6BA54-1	5322, 3B, AP2054-1	38, AX1449-2	2, AP2054-1	55404	5, 8AA12-1	561781, 59, BP183-3
493370, 2, 11AB10-1	5323, 75, 11AA10-2,	550557	551768, 4AA20-0	22, 8AA12-1, 8AA22-1	561528	561782, 59, BP183-3
493481, 22, 12AA10-1	11AA11-2,	2, AX1417-1	551774, 13, 10CE15-1	24, 8AA12-1, 8AA22-1	11, 8AA23-1	561783, 59, BP183-3
49369, 6BA54-1	11AA20-2,	38, AX1449-2	551880	554629	12, 8AA13-1	561784, 38, BP179-2,
49370, 4, 6BA54-1	11AA21-2	550570, 7, AP1432-1	28, 8AA21-1	11, 11CC09-1	561529	BP183-2
493729, 2, 4AA30-1	53501	550626	33, 8AA11-2	5, 11BA10-1	15, 8AA13-1	561785, 31, BP179-2,
493789, 4, 6BB21-1	26, 9AA11-1	35, BP 178-2	44, 8AA12-2, 8AA22-2	55714	16, 8AA23-1	BP183-2
494171, 2AA79-0	8, 6BB10-1	40, BP 182-2	46, 8AA22-2	17, 6BA10-1	561531	561786, 28, BP179-2,
494496, 7, 10AA30-1	5398	550627	55, 8AA12-2	18, 6BA20-1	31, 8AA23-1	BP183-2
494743, 4, AP2054-1	11, 6BB20-1	36, BP 178-2	551882	561086	33, 8AA13-2	561787, 58, BP183-3
494918, 16, 12AA10-1	6, 6BB10-1	41, BP 182-2	11, 8AA22-1	17, 8AA21-1	561535, 26, 8AA14-1	561788, 39, BP179-2,
495931	54232	550632, 40, BP179-2,	4, 8AA21-1	18, 8AA11-1	561544	BP183-2
14, 8AA110-1	11, 11AB10-1	BP 183-2	9, 8AA11-1	561087	45, 8AA22-2	561789, 19, BP179-1,
2, 8AA112-1	13, 11BA30-1	550636, 49, BP179-3,	552412, 13, AP1435-1	26, 8AA21-1	54, 8AA12-2	BP183-1
6, 8AA111-1	14, 6AA32-1, 8AA16-1	BP183-3	552413, 10, AP1435-1	31, 8AA11-2	561620, 11, 10CE15-1	561790, 26, BP179-2,
496143, 13, 12AA10-1	32, 9AA10-1, 9AA11-1	550649, 8, 8AA14-1	552426, 1, 8AA11-1,	561088, 1, 8AA15-1	561621, 10, 10CE15-1	BP183-2
496162, 24, 12AA10-1	50, 8AA12-2	550705	8AA21-1	561089, 29, 8AA14-2	561622, 9, 10CE15-1	561791, 1, BP179-1,
803666, 23, 12AA10-1	8, 11BA20-1	3, BP 178-1, BP 182-1	552448, 55, 8AA11-2	561090, 2, 8AA15-1	561623, 3, 10CE15-1	BP183-1
496425, 12, AX1412-1	95, 11AA10-2,	56, BP179-3	552502	561091, 28, 8AA14-1	561624, 5, 10CE15-1	561792, 20, BP179-1,
496426, 21, AX1449-1	11AA11-2,	75, BP183-4	32, BP 178-2	561092, 8, 8AA11-1	561625, 6, 10CE15-1	BP183-1
496428, 22B, AX1418-1	11AA20-2,	551239, 3, 10DA88-1	37, BP 182-2	561093, 7, 8AA11-1	561637, 2, 10CE15-1	561794, 25, BP179-2,
496429, 27B, AX1418-1	11AA21-2	551242, 66, 10AE10-3	8, 11CD58-1	561110	561747, 67, 10AE10-3	BP183-2
496430, 62A, AX1225-3	54242	551255, 8, 4AA51-1	552504, 33, BC139-2	31, 8AA21-2	561749, 2AA79-0	561795, 15, BP179-1,
496431, 64A, AX1225-3	17, 8AA110-1	551256, 9, 4AA51-1	552509, 4, AX1225-1	36, 8AA11-2	19, BP 178-1	BP183-1
496538, 3, 12AA10-1	19, 11CCD31-1	551257, 11, 4AA51-1	552510, 52, AX1225-3	561187, 3, BC108-1	24, BP 182-1	561796, 14, BP179-1,
496647, 2, 6BB21-1	6, 8AA12-1, 8AA120-1	551258, 10, 4AA51-1	552512, 36, AX1225-2	561198, 2, BC108-1	561757, 1, BP 182-1	BP183-1
496680	54557	551259, 12, 4AA51-1	552513, 22, AX1225-1	561248	561758, 2, BP 182-1	561797, 12, BP179-1,
18, 11BA30-1	30, 8AA13-1	551373, 46, BP179-3	552514, 16, AX1225-1	45, 8AA11-2	561759, 5, BP 182-1	BP183-1
19, 11BA20-1	39, 8AA23-2	551522, 70, 8AA12-3	552515, 5, AX1225-1	56, 8AA11-3	561760	561798, 13, BP179-1,
496687, 62, 11AA10-2,	6, 11CC11-1	551555	552516, 34, AX1449-2	561322, 13, 11AA10-1,	30, BP 178-2	BP183-1
11AA11-2,	54564	31, 8AA12-2, 8AA22-2	552517	11AA20-1	35, BP 182-2	561799, 18, BP179-1,
11AA20-2,	22, 8AA13-1	39, 8AA12-2, 8AA22-2	2, AX1417-1	561338, 6, 11CD58-1	49, BP 178-2	BP183-1
11AA21-2	40, 8AA23-2	551556	38, AX1449-2	561340, 7, 10DA88-1	54, BP 182-2	561800, 17, BP179-1,
496702, 5, 10AA30-1	54568	32, 8AA12-2, 8AA22-2	552518, 11, AX1225-1	561342	561761	BP183-1
496718, 6, 6BB21-1	32, 8AA21-2	38, 8AA12-2, 8AA22-2	552522, 17, AX1225-1	34, 8AA23-1	50, BP 178-2	561801, 16, BP179-1,
496725, 35, 4AB10-2	35, 8AA13-2	551557, 37, 8AA12-2,	552523, 48, AX1225-3	37, 8AA13-2	55, BP 182-2	BP183-1
496735, 17, 12AA10-1	37, 8AA11-2	8AA22-2	552524, 2, AX1225-1	561375, 4, AP1430-1	561762, 23, BP179-2,	561802, 11, BP179-1,
496810, 18, 10AA30-1	41, 8AA11-2	551558	552528, 58, AX1225-3	561414, 1, AP1430-1	BP183-2	BP183-1
496816	42, 8AA23-2	30, 8AA12-2, 8AA22-2	552531, 28, AX1225-2	561426, 17A, 8AA12-1,	561763, 61, BP183-3	561803, 9, BP179-1,
15B, AP2054-1	548112, 4, 10DA88-1	40, 8AA12-2, 8AA22-2	552532, 49, AX1225-3	8AA22-1	561764, 24, BP179-2,	BP183-1
34, 10AA30-2	548894, 12, 10DA88-1	551560	552537, 26, AX1225-2	561515	BP183-2	561804, 10, BP179-1,
496829, 27, 10AE10-2	549100	7, 8AA13-1	552538, 21, AX1225-1	15, 8AA21-1	561765	BP183-1
496830, 21, 10AE10-1	10, 11CD58-1	9, 8AA23-1	552608, 4, BC108-1	16, 8AA11-1	22, BP 178-1	561805, 7, BP179-1,
496861, 33, 10AE10-2	13, BP 178-1	551582	552622, 25, BC139-1	561518	27, BP 182-1	BP183-1
496961, 5, 11CD10-1	17, BP 182-1	1, 8AA13-1, 8AA23-1	552629, 3, BC139-1	12, 8AA21-1	561766, 62, BP183-3	561806, 8, BP179-1,
497922	549222, 8, 8AA15-1	10, 8AA23-1	552634, 15, BC139-1	20, 8AA11-1	561767, 68, BP183-3	BP183-1
30, 6BB10-2	54951	11, 8AA13-1	552639	561519	561768, 63, BP183-3	561807
34, 6BB20-2	2, 6BB10-1	2, 8AA13-1, 8AA23-1	17, AP2054-1	21, 8AA21-1	561769, 66, BP183-3	48, BP179-3, BP183-3
504389, 21, 11CC09-1	27, 6BB20-1	551600	33, 10AA30-2	26, 8AA11-1	561770, 67, BP183-3	70, BP183-3

PARTS INDEX: Part no., Item no., Page (Drawing Ref. no.)

CATALOG 802832, R03-04

561808, 69, BP183-3	16, BP 178-1	562043, 4, BP180-1,	562472	562522, 18, AX1415-1	563748, 1, 11CD58-1	5804
561809, 22, BP179-2, BP183-1	21, BP 182-1	BP184-1	1, AX1417-1	562523, 23, AX1415-1	563794, 22, 11CC09-1	10, 11CD31-1
561810, 51, BP179-3, BP183-3	561838, 55, BP183-3	562044, 12, 11AA10-1, 11AA20-1	44, AX1449-2	562524, 24, AX1415-1	563796, 18, 11CC09-1	14, 8AA104-1
561812	561839, 56, BP183-3	562046	562474, 5, AX1449-1, AX1417-1	562525, 13, AX1415-1	563798, 15, 11CC09-1	23, 9AA10-1
58, BP179-3	561840, 1, BP 178-1	32, 8AA14-2	562475, 14, AX1418-1	562526, 1, AX1419-1	563799, 19, 11CC09-1	51, 10AE10-2
77, BP183-4	561841, 2, BP 178-1	49, 8AA11-2	562476, 9, AX1449-1, AX1417-1	562531, 2, AX1412-1, AX1416-1	563800, 17, 11CC09-1	9, 6BA10-1
561813	27, BP 178-1	562051	562477, 10, AX1449-1, AX1417-1	562547, 1, AX1415-1	563864	58112, 20, BC139-1
59, BP179-3	32, BP 182-2	33, 8AA23-1	562478, 11, AX1449-1, AX1417-1	562548, 4, AX1415-1	38, 8AA21-2	58113, 21, BC139-1
78, BP183-4	561931, 60, BP 178-2, BP 182-3	36, 8AA13-2	562479, 12, AX1449-1, AX1417-1	562550, 7, AX1415-1	42, 8AA11-2	581732, 8, 9AA10-1
561814	561932	562070, 64, 8AA11-3	562480, 13, AX1449-1, AX1417-1	562554, 20, AX1415-1	563903, 6, AX1418-1	58202
52, BP179-3	70, BP179-3	562072	562481, 14, AX1449-1, AX1417-1	562665	563904	16, 6BA10-1
71, BP183-4	90, BP183-4	65, 8AA11-3	562482, 15, AX1417-1	35, 8AA23-1	22, AX1417-2	17, 6BA20-1
561815	561933	66, 8AA11-3	562483	38, 8AA13-2	43, AX1449-2	58523, 10, 11BA20-1
53, BP179-3	71, BP179-3	68, 8AA11-3	562484	562706, 74, 10AE10-3	563905, 16, AX1415-1	58528
72, BP183-4	91, BP183-4	69, 8AA11-3	562485	562750, 2, AX1418-1	563906, 26, AX1415-1	10, 8AA13-1,
561816	561934	562086, 35, 10AA40-1	15, AX1225-1	562752, 10, AX1418-1	564073	8AA111-1
44, BP 178-2	61, BP 178-2, BP 182-3	562088, 37, 10AA40-1	23, AX1417-2	563287, 21, AP1436-1	1, AX1225-1	11, 4AA31-1
49, BP 182-2	72, BP179-3	562089, 42, 10AA40-1	45, AX1449-2	563288, 22, AP1436-1	77, 4AB11-2	14, 8AA106-1
561818, 64, BP183-3	92, BP183-4	562090, 41, 10AA40-1	562486, 24, AX1449-1, AX1417-2	563289, 9, AP1436-1	564074, 46, AX1225-2	19, 6BB21-1
561819, 65, BP183-3	561935, 93, BP183-4	562092, 39, 10AA40-1	562488, 24, AX1449-1, AX1417-2	563290, 10, AP1436-1	564076, 3, AX1225-1	21, 4AB12-1
561820	561936	562093, 43, 10AA40-1	562489, 4A, AX1418-1	563291, 11, AP1436-1	564133	26, 6BB20-1
46, BP 178-2	62, BP 182-3	562095, 40, 10AA40-1	562490	563292, 19, AP1436-1	13, AX1450-1	3, 8AA23-1
51, BP 182-2	94, BP183-4	562148	2, AX1450-1	563294, 25, AP1436-1	33, AX1418-2	5, 8AA120-1
561821	561937	65, BP 182-3	5, AX1418-1	563295, 2, AP1435-1	564147, 27, 8AA14-1	50, 6BB10-2
48, BP 178-2	63, BP 182-3	99, BP183-4	562499, 20, AX1418-1	563298, 4, AP1437-1	564148, 25, 8AA14-1	6, 8AA50-1, 11BA20-1
53, BP 182-2	95, BP183-4	562173, 35, 8AA14-2	562500, 21, AX1418-1	563299, 6, AP1437-1	564149, 10, 8AA14-1	7, 8AA40-1
561822	561938, 96, BP183-4	562181, 38, 8AA11-2	562503, 28A, AX1418-2	563300, 14, AP1437-1	5642, 2, 11CD58-1	8, 4AA10-1, 8AA122-1,
25, BP 178-1	561939, 97, BP183-4	562185, 2AA79-0	562504	563301, 16, AP1437-1	564214, 44, AX1225-2	11BA30-1
30, BP 182-2	561940	46, 8AA11-2	11, AX1450-1	563329, 34, 4AC11-1	564215, 40, AX1225-2	9, 8AA110-1,
561823	78, BP179-3	562186, 51, 8AA11-2	5, AX1418-1	563415, 2AA79-0	564216, 42, AX1225-2	11CC12-1
41, BP 178-2	98, BP183-4	562187, 71, 8AA11-3	562499, 20, AX1418-1	563416, 2AA79-0	564221, 34B, AX1225-2	97, 11AA10-2,
46, BP 182-2	561941, 64, BP 182-3	562188	562500, 21, AX1418-1	563447, 9, 6BA54-1	564223, 10, AX1225-1	11AA11-2,
561824, 10, BP 182-1	561942	40, 8AA21-2	562503, 28A, AX1418-2	563448, 10, 6BA54-1	564224, 25B, AX1225-2	11AA20-2,
561825, 9, BP 182-1	65, BP 178-2	52, 8AA11-2	562504	563449, 11, 6BA54-1	564226, 39, AX1225-2	11AA21-2
561826, 11, BP 182-1	79, BP179-3	562189, 58, 8AA11-3	11, AX1450-1	563487, 25, 4AA10-1	564234, 14, AX1415-1	58530, 8, 11CD31-1
561827	561943, 3, BP180-1, BP184-1	562190, 60, 8AA11-3	29, AX1418-2	563488, 30, 4AA10-1	564242, 63A, AX1225-3	58531
23, BP 178-1	BP184-1	562192, 63, 8AA11-3	562508	563489, 1, 4AA10-1	564243, 47, AX1225-2	22, 4AB12-1
28, BP 182-1	561944, 2, BP180-1, BP184-1	562193, 67, 8AA11-3	16, AX1450-1	563497, 7, AX1225-1	564245, 38, AX1225-2	4, 11CC12-1
561828	561945	562196, 7, 8AA12-1	35, AX1418-2	563501, 45, AX1225-2	564246, 43, AX1225-2	58536
24, BP 178-1	42, BP 178-2	562197, 8, 8AA12-1	562509	563502, 37, AX1225-2	564247, 41, AX1225-2	11, 10AE10-1
29, BP 182-2	47, BP 182-2	562198, 9, 8AA12-1	17, AX1450-1	563506, 9, AP1432-1	564248, 8, AX1225-1	31, 6BA10-2
561829	561946	562199, 11, 8AA12-1	36, AX1418-2	56354	564250, 31, AX1225-2	5, 6BA20-1
15, BP 178-1	40, BP 178-2	562201, 29, 8AA12-2	562510	11, 6BA10-1	564332, 27, AP1436-1	66, 4AB11-1
19, BP 182-1	45, BP 182-2	562202, 33, 8AA12-2, 8AA22-2	18, AX1450-1	12, 10AE10-1	564333, 28, AP1436-1	58538
561830	561947, 32, AX1225-2	562205	37, AX1418-2	13, 4AA30-1,	564334, 24, AP1436-1	10, 10AE10-1
39, BP 178-2	562001, 73, BP179-3	49, 8AA22-2	562512	8AA110-1	564341, 29, AP1436-1	5, 4AA30-1
44, BP 182-2	562002	58, 8AA12-3	25, AX1450-1	16, 9AA10-1	564646, 1, AP1435-1	58546
561831, 20, BP 182-1	62, BP 178-2	562207, 76, 8AA11-3	42, AX1418-2	3, 4AA20-1	564679, 57A, AX1418-2	20, 4AB10-1,
561833	74, BP179-3	562265, 35, AX1449-2	562513	5, 8AA111-1	564681, 57A, AX1418-2	4AB10.2-1
7, BP 178-1	562003	562317, 5, BC108-1	24, AX1450-1	6, 8AA112-1	564693, 3, AX1420-1	3, 4AA50-1
8, BP 182-1	63, BP 178-2	562318, 6, BC108-1	43, AX1418-2	7, 8AA10-1, 8AA20-1	564898, 19, AX1418-1	6, 4AB12-1
561834	75, BP179-3	562319, 7, BC108-1	562514	8, 11BA40-1	564903, 18, AX1418-1	8, 4AA40-1
26, BP 178-1	562004, 76, BP179-3	562320, 8, BC108-1	12, AX1450-1	564961, 2, AP1437-1	564961, 2, AP1437-1	58548
31, BP 182-2	562005, 77, BP179-3	562320, 8, BC108-1	44, AX1418-2	565998	565998	11, 4AA10-1
561835	562006, 64, BP 178-2	562353, 73, 10AE10-3	562515	14, AX1450-1	14, AX1450-1	13, 6BA20-1
12, BP 182-1	562007, 77, BP179-3	562427, 5, AX1225-1	15, AX1450-1	34, AX1418-2	34, AX1418-2	14, 4AA40-1, 4AB10-1,
8, BP 178-1	562008, 64, BP 178-2	562461, 34, 10AA40-1	49, AX1418-2	34, 6BA10-2	572281ACC, 17B, 8AA22-1	4AB10.2-1
561836	562040	562469, 3A, AX1416-1	562516, 25, AX1415-1	563551, 3, 6BA54-1	57446	21, 4AA50-1
21, BP 178-1	43, BP 178-2	562470, 5, AX1412-1, AX1416-1	562520, 21, AX1415-1	563552, 6, 6BA54-1	5, 8AA40-1, 8AA50-1	23, 10DA88-1
26, BP 182-1	48, BP 182-2		562521, 17, AX1415-1	563553, 7, 6BA54-1	6, 8AA110-1	28, 6BA10-1
561837						6, 10AE10-1

PARTS INDEX: Part no., Item no., Page (Drawing Ref. no.)

CATALOG 802832, R03-04

58557, 8, 4AB10-1, 4AB10.2-1	601935, 2, AX1449-1	603316, 23, AX1450-1	61323	63546	79126, 11, 11AA10-1, 11AA11-1, 11AA20-1, 11AA21-1	1, 4AB10-1, 4AB10.2-1 65A, AX1225-3 78A, 4AB11-2
58574, 24, 7AA11-1	601937, 18, AX1449-1	603317, 30, AX1450-1	15, 8AA106-1	20, 9AA10-1, 9AA11-1	802010, 24, 6BB20-1	
58588	601941, 16, AX1449-1	603479, 3A, AP2054-1	65, 10AE10-3	3, 6AA11-1	802025, 1, 8AA103-1	
10, 4AA50-1	601943, 17, AX1449-1	603534, 2, BC139-1	603534, 2, BC139-1	63547	802036, 5A, 4AA31-1	
11, 4AA40-1	601944, 28, AX1449-1	603593, 20, 11CC09-1	61674	11, 4AB10-1, 4AB10.2-1	802047	
58633, 1, 7AB10-1, 8AA100-1	601945, 1, AX1449-1	603638	10, 8AA22-1	13, 4AA31-1	18, 6AA30-1	
600365	601946, 29, AX1449-2	26, AX1418-1	11, 8AA14-1	3, 10AE10-1	3, 6AA20-1	
66, BP 178-2	601947, 30, AX1449-2	4, AX1450-1	12, 4AA31-1, 4AC11-1	63727	802048, 6A, 7AB10-1	
67, BP 182-3	601948, 31, AX1449-2	6, AX1412-1,	15, 8AA105-1,	10B, 4AC11-1	802049, 6B, 7AB10-1	
600366	601949, 23, AX1449-1	AX1416-1	8AA106-1	14, 8AA120-1	802054, 19, 6BB20-1	
66, BP 182-3	601950, 32, AX1449-2	603639	20, 4AB12-1, 6BB21-1	6, 11BA40-1	802082	
67, BP 178-2	601983, 24A, AX1225-2	25, AX1418-1	25, 6BB20-1	7, 10AA20-1	10, 8AA110-1	
600525, 28, BC139-1	601998, 26, AX1449-1	5, AX1450-1	3, 8AA40-1, 8AA50-1,	9, 8AA122-1,	4, 8AA111-1	
600549, 4A, AX1416-1	602007, 38, AX1415-1	7, AX1412-1,	11BA20-1	10AA10-1	5, 8AA112-1	
600552, 25, AX1417-2	602061, 7, BC139-1	AX1416-1	36, 8AA12-2	63754	802113, 10, 3AA10-2	
600558, 37, AX1415-1	602062, 16, BC139-1	603640, 26, AX1450-1	4, 8AA30-1, 11CD10-1	18, 10AE10-1	802114, 25, 3AA20-1	
600559, 15, AX1418-1	602063, 19, BC139-1	603648, 3, AX1417-1	40, 8AA14-2	3, 7AA11-1	802118, 4, 3AA10-1	
600582, 36, AX1415-1	602064, 22, BC139-1	603649, 3, AX1418-1	48, 6BB10-2	5, 11CC12-1	802120, 2, 4AB10-1, 4AB10.2-1	
600593, 12, AX1225-1	602065, 29, BC139-2	603650, 11, AX1418-1	5, 8AA23-1, 11BA30-1	63936, 9, 6AA10-1	802126, 11, 3AA10-2	
600594, 66, AX1225-3	602072, 37, 8AA14-2	603651, 13, AX1418-1	7, 4AA10-1, 8AA110-1	675, 11, 11BA20-1	802127, 3, 3AA10-1	
600595, 18, AX1225-1	602094, 12, 10AA40-1	603652, 22A, AX1418-1	8, 8AA13-1, 8AA111-1,	676, 12, 11BA20-1	802128, 17, 3AA10-2	
600596, 23, AX1225-1	602095, 16, 10AA40-1	603652, 22A, AX1418-1	8AA120-1,	686226, 13, 11AA11-1,	802133, 12, 11BA30-1	
600597, 24B, AX1225-2	602096, 2AA79-0	603655, 60, AX1418-3	11CC12-1	11AA21-2	802161, 1A, 4AC10-1	
600598, 62B, AX1225-3	13, 10AA40-1	603656, 4A, AX1419-1	86, 11AA10-2,	686227, 2, 11AA11-1,	802162, 1, 10AA10-1, 10AA20-1	
600599, 64B, AX1225-3	602097, 14, 10AA40-1	603657, 5, AX1419-1	11AA11-2,	11AA21-1	802209, 16A, 7AA11-1	
600600, 63B, AX1225-3	602098, 17, 10AA40-1	603681, 7A, AX1419-1	11AA20-2,	686232, 4AB10.5-0	802239, 2A, 9AA10-1	
600670	602099, 15, 10AA40-1	603723, 59B, AX1418-3	11AA21-2	686343	802242, 3, 9AA10-1	
22, AX1450-1	602106, 28, 4AC11-1	603821, 3B, AX1416-1	9, 8AA102-1, 8AA103-1	1, 11AA11-1, 11AA21-1	802263, 12, 10AA10-1	
40, AX1418-2	602190, 59A, AX1418-3	603844, 1, 8AA12-1	61676	1B, 11AA10-1, 11AA20-1	802274, 10, 10AA20-1	
600726, 20, 10DA88-1	602218, 6, AX1415-1	603845	12, 4AB10-1, 4AB10.2-1	702059, 57B, AX1418-3	802276, 11, 10AA20-1	
600753, 25, 10DA88-1	602219, 45B, AX1418-2	59, 8AA22-2	14, 4AA10-1, 6BA20-1	702060, 57B, AX1418-3	802288, 7, 4AC10-1	
600792	602220, 41A, AX1418-2	63, 8AA12-3	18, 11CC14-1	702067, 4B, AX1419-1	802292, 16, 4AB10-1, 4AB10.2-1	
1, BP180-1, BP184-1	602225, 61, AX1418-3	603846	29, 6BA10-2, 10AE10-2	702138	802333, 12, 4AA10-1	
51, BP 178-2	602293	39, 8AA13-2	5, 4AA50-1	3, AX1450-1	802354	
56, BP 182-2	14, AX1412-1	43, 8AA23-2	6, 4AA40-1	4B, AX1418-1	13, 10AA10-1	
600830, 39, 8AA11-2	4B, AX1416-1	603847	61680	702147, 7B, AX1419-1	23, 10AA20-1	
600831, 20, 8AA14-1	602296, 15, AX1415-1	40, 8AA13-2	10, 4AB10-1, 4AB10.2-1	71940, 25, 4AA50-1	802358, 55, 10AE10-3	
600832, 30, 8AA14-2	602729, 5, BP179-1, BP183-1	44, 8AA23-2	15, TIER 2-1	72339, 3, 10AF10-1	802367, 28, 10AE10-2	
600833, 4, 8AA15-1	602730	603848	39, 6BB11-1	72437, 49, 8AA12-2	802451, 13, 10AA20-1	
600834, 9, 8AA15-1	100, BP183-4	41, 8AA13-2	603849	73191, 20, 10AE10-1	802456, 3, 4AB10A-1	
601243, 8, AX1449-1, AX1417-1	80, BP179-3	45, 8AA23-2	603850	73979, 3, 4AA30-1	802457, 4, 4AB10A-1	
601246	602780, 36, AX1449-2	603851	61683	75498, 19, 4AB12-1	802458, 5, 4AB10A-1	
31, AX1418-2	602787, 1, AX1450-1	43, 8AA13-2	2, 7AB10-1	75992, 8, 6AA10-1	802461, 1, 4AB10A-1	
9, AX1450-1	602788, 7, AX1450-1	47, 8AA23-2	8, 7AA10-1	76571, 27, 12AA10-1	802462, 2, 4AB10A-1	
601323, 36, 8AA14-2	602789, 20, AX1450-1	603852, 1, 8AA22-1	9, 7AA11-1	804768, 2, 12AA10-1	802470, 8, 8AA100-1	
601324, 38, 8AA14-2	602877, 2, AP1432-1	603891, 4, AP1432-1	61799	77808, 31, 10AA30-2	802491, 6, 4AA30-1	
601558, 3, AX1449-1	603205, 9, AP2054-1	603999, 10, AP1432-1	21, 8AA13-1	77957	802498, 7, 4AA30-1	
601561, 6, AX1420-1	603208, 8, AP2054-1	604031, 1, AP1432-1	41, 8AA23-2	1, 6BB21-1	802504, 13, 4AA31-1	
601570, 8, AP1435-1	6033210, 14, 8AA14-1	604252, 41B, AX1418-2	61801, 10, 11BA40-1	32, 6BB11-1	802513, 1, 11BA40-1	
601589, 8, BC139-1	603303, 20, AX1449-1	604253, 41, AX1415-1	62179, 5, 4AB12-1	78086, 4, 4AA51-1	802514, 2, 11BA40-1	
601590, 13, BC139-1	603304	604656	62203	78088, 13, 4AA51-1	802516, 11CD20-1	
601592, 30, BC139-2	40, 8AA11-2	28B, AX1418-2	27, 4AB10-2, 4AB10.2-2	78179	129, 11AA20-3, 11AA21-3	
601593, 17, BC139-1	42, 8AA21-2	6, AX1450-1	8, 4AA50-1	19, 6BB10-1	1, AX2519A-1	
601594, 14, BC139-1	603306	604854, 57B, AX1418-3	9, 4AA40-1	2, 6BB20-1	2, 6AA31-1	
601597, 18, BC139-1	29, 8AA23-1	60998, 16, 4AB12-1	63544	78237	4, 6AA20-1	
601673, 7, 11CD58-1	31, 8AA13-2	61308	12, 8AA101-1	12, 6BB20-1	801992	
601679, 16, 11CC09-1	603310, 15, AX1449-1	15, 7AA11-1	13, 8AA102-1	13, 6BB10-1		
601824, 27, 4AC11-1	603311, 19, AX1449-1	19, 4AB10-1,	8AA103-1	78310, 9, 8AA104-1		
601845, 23, 11CC09-1	603312, 25, AX1449-1	4AB10.2-1	16, 8AA105-1, 8AA106-1	78806, 93, 11AA10-2, 11AA11-2		
601846, 24, 11CC09-1	603313, 46, AX1449-2					

PARTS INDEX: Part no., Item no., Page (Drawing Ref. no.)

CATALOG 802832, R03-04

802600-B, 2A, 6AA10-1 802615, 4A, 9AA10-1 802616, 5A, 9AA10-1 802643, 1, 8AA122-1 802645, 2, 8AA122-1 802649 11, 8AA120-1 2, 11BA20-1 3, 11BA30-1 4, 8AA122-1	802821, 4, 8AA16-1, 11AB10-1 802822 20, 8AA16-1 3, 11AB10-1 802826, 17A, 8AA30-1 802833, 11, 12AA10-1 802836, 2A, 8AA110-1 802852, 2A, 8AA40-1, 8AA50-1 802861, 11CC101, 11CC102 13, 8AA30-1 7, 8AA50-1 8, 8AA40-1 802874, 28, 9AA10-1 802876, 4, 6BB20-1 802884, 39, 9AA11-1 802885, 7, 4AA31-1 802887, 8, 4AA31-1 802889, 6, 4AA31-1 802892, 19, 4AA31-1 802893, 20A, 4AA31-1 802895L, 12, 3AA10-2 802895R, 12, 3AA10-2 802896, 13, 3AA10-2 802897, 47, 4AB10-2 802898, 44, 4AB10-2, 4AB10.2-2 802903 1, BC139-1 51, 4AB11-1 802907 15, 10AA20-1 16, 10AA10-1 802909 16, 10AA20-1 17, 10AA10-1 8, 4AC10-1	802983, 1, 10AF10-1 802986, 81, 11AA10-2, 11AA11-2 802988L, 2, 3AA10-1 802988R, 1, 3AA10-1 802989, 3, 3AA10-1 802991L, 21, 3AA20-1 802991R, 21, 3AA20-1 802992, 22, 3AA20-1 802994L, 28, 3AA20-2 802994R, 28, 3AA20-2 802995, 29, 3AA20-2 802997L, 15, 3AA10-2 802997R, 15, 3AA10-2 802998, 16, 3AA10-2 803000L, 18, 3AA10-2 803000R, 18, 3AA10-2 803001, 19, 3AA10-2 803003L, 24, 3AA20-1 803003R, 24, 3AA20-1 803004, 26, 3AA20-1 803006L, 5, 3AA10-1 803006R, 5, 3AA10-1 803007, 6, 3AA10-1 803010L, 7, 3AA10-1 803010R, 7, 3AA10-1 803011, 8, 3AA10-1 803012, 21A, 4AA31-1 803019, 13, 10AF10-1 803020, 15, 10AF10-1 803021, 6, 10AF10-1 803023, 37, 10AE10-2 803025, 13, 10AE10-1 803026 32, 10AE10-2 65, 4AB11-1 803027, 41, 10AE10-2 803028, 39, 10AE10-2 803030 38, 10AE10-2 8, 10BA10-1 803031, 23, 10AE10-1 803032, 24, 10AE10-1 803033, 42, 10AE10-2 803034, 15, 10AE10-1 803035, 14, 10AE10-1 803036, 26, 10AE10-2 803037, 25, 10AE10-1 803038, 131, 11AA10-3, 11AA11-3, 11AA20-3, 11AA21-3 803039 20, 10AA20-1 21, 10AA10-1 803042, 19, 6AA32-1 803047, 8A, 8AA50-1 80305, 12, 6BB10-1 803058, 6A, 8AA40-1 803061, 4, 11BA30-1 803071, 2AA79-0 803074, 12AA10-0 803077, 15, 8AA102-1	803079, 41, 9AA10-1 80308, 5, 4AA51-1 803103, 17, 8AA105-1, 8AA106-1 803112, 18, 8AA105-1, 8AA106-1 803120, 20, 8AA106-1 803128, 21, 8AA106-1 803129, 22, 8AA106-1 803136, 19, 8AA105-1 803138, 8AA124-1 803139, 8AA123-1 803140, 3, 8AA124-1 803141, 3, 8AA123-1 803142, 2, 8AA124-1 803143, 2, 8AA123-1 803144, 1, 8AA124-1 803145, 1, 8AA123-1 803146, 20, 8AA105-1 803147, 21, 8AA105-1 803148, 28, 12AA10-1 803149, 29, 12AA10-1 803150, 30, 12AA10-1 803151, 31, 12AA10-1 803152, 32, 12AA10-1 803153, 33, 12AA10-1 803154, 34, 12AA10-1 803155, 35, 12AA10-1 803156, 36, 12AA10-1 803157, 37, 12AA10-1 803167, 11CC11-1 803168 1, 11CC11-1 22, 11CC12-1 803169, 2, 11CC11-1 803170, 3, 11CC11-1 803173, 1, 4AB12-1 803174, 14, 4AB12-1 803175, 11, 4AB12-1 803176, 12, 4AB12-1 803177 4, 10AF10-1 5, 10BA10-1 803178, 3, 4AB12-1 803179, 2, 4AB12-1 803180, 15, 4AB12-1 803181, 17, 4AB12-1 803182 24, 4AB12-1 7, 10AF10-1 803183, 25, 4AB12-1 803184 16, 10AF10-1 26, 4AB12-1 6, 10BA10-1 803185, 18, 4AB12-1 803187, 1, 10BA10-1 803188 10, 10BA10-1 6, 6AA32-1 803189, 2, 10BA10-1 803190, 12, 10BA10-1 803191, 3, 10BA10-1	803192, 4, 10BA10-1 803193, 7, 10BA10-1 803194, 11, 10BA10-1 803196 4, 4AB12-1 5, 10AF10-1 803198, 18, 10AF10-1 803199, 19, 10AF10-1 803200, 14, 10AF10-1 803201, 23, 11CC12-1 803202 19, 11CC12-1 24, 11CC12-1 803205, 2, 4AB10-1, 4AB10.2-1 803208, 5, 11CC12-1 803209, 6, 11CC12-1 803229, 12, 6AA30-1 803269, 12, 10AA20-1 803270, 58, 4AB11-1 803271, 33, 4AB10-2, 4AB10.2-2 803272, 57, 4AB11-1 803274 41, 4AB10.1-1 43, 4AB10-2 803275, 42, 4AB10-2, 4AB10.2-2 803282, 4, 7AB10-1 803284, 4A, 7AA10-1 803285, 32, 7AA11-2 803288, 1, 6AA32-1 803289, 2, 6AA32-1 803290, 4, 6AA32-1 803291, 9, 6AA32-1 803293, 56, 10AE10-3 803313, 42, 12AA10-1 803326, 2B, 10AE10-1 803328, 1B, 10AE10-1 803337, 2A, 10AE10-1 803338, 1A, 10AE10-1 803388, 4AA51-1 803393 12, 8AA50-1 13, 8AA50-1 803396, 4, 11CC13-1 803399, 1, 11CC14-1 803409, 11, 10AA30-1 803411, 12B, 4AC10-1 803412, 2, 11CC14-1 803415, 14, 11CC14-1 803416, 13, 11CC14-1 803417, 17B, 8AA12-1 803419 19, 6BA10-1 21, 6BA20-1 803422, 44, 11AA11-1, 11AA21-1 803450 18, 6BA10-1 6, 11CD10-1 8, 6BA20-1	803451, 2B, 9AA10-1 803453, 11A, 4AC10-1 803454, 46, 4AB10-2, 4AB10.1-1, 4AB10.2-2 803455, 45, 4AB10-2, 4AB10.2-2 803458, 12, 8AA122-1 803461, 13, 8AA122-1 803470-1, E, 10AE11-1 803470-2, F, 10AE11-1 803470-3, G, 10AE11-1 803483, 34, 4AB10-2 803486, 8, 11CC13-1 803487, 9, 11CC13-1 803499, 12, 8AA120-1 803501, 11A, 4AA20-1 803506, 13, 8AA120-1 803525, 7, 11CC12-1 803529, 11B, 4AA20-1 803532 22, 10AA20-1 23, 10AA10-1 803536, 1B, 4AC10-1 803543, 10, 3AA20-2 803544, 10, 6AA30-1 803545, 11, 6AA30-1 803560, 8, 6AA20-1 803562, 1B, 8AA40-1, 8AA50-1 803566 36, 4AB11-1 38, 4AB10.1-1, 4AB10.2-2 803570 39, 4AB10.1-1, 4AB10.2-2 41, 4AB11-1 803576, 26, 7AA11-2 803585 40, 4AB10.1-1, 4AB10.2-2 69, 4AB11-1 803611 37, 4AB10.1-1, 4AB10.2-2 70, 4AB11-1 803614, 15, 6AA30-1 803617, 14, 6AA30-1 803653, 36, 4AA10-1 803656, 38, 4AA10-1 803663, 2B, 8AA40-1, 8AA50-1 803668, 1, 7AA11-1 803671, 7AA11-1 4b, 7AA10-1 803677, 1B, 9AA11-1 803684, 27, 4AB12-1 803726, 15, 10AA30-1 803729, 2, 10AA30-1 803730, 1, 10AA30-1 803732, 52, 6BB10-2 803733, 4AB10.5-0	24, 10AA20-1 803735, 26, 10AA20-1 803746, 5B, 8AA30-1 803762, 31B, 6BB10-2 803765, 35, 4AB10.2-2 803768, 5, 6AA11-1 803817, 2, 10AE11-1 803818, 1, 10AE11-1 803820, 3, 10AE11-1 803821, 4, 10AE11-1 803822, 5, 10AE11-1 803823, 6, 10AE11-1 803824, 7, 10AE11-1 803825, 8, 10AE11-1 803826, 9, 10AE11-1 803827 46B, 10AE10-2 H, 10AE11-1 803828, 21, 10AA30-1 803829, 39, 4AB10.2-2 803840, 11, 10AE11-1 803841, 10, 10AE11-1 803842, 16B, 10AE11-2 803843, 15B, 10AE11-2 803844, 14D, 10AE11-2 803845, 13D, 10AE11-1 803855, 16A, 10AE11-2 803856, 15A, 10AE11-2 803857, 13B, 10AE11-1 803858, 14B, 10AE11-2 803859, 13A, 10AE11-1 803860, 14A, 10AE11-2 803861, 13C, 10AE11-2 803862, 14C, 10AE11-2 803863, 8, 11CC14-1 803864, 9, 11CC14-1 803865, 6, 11CC14-1 803866, 7, 11CC14-1 803871, 17, 11CC14-1 803872, 16, 11CC14-1 803875, 14, 4AA51-1 803885, 48, 4AB10.2-2 803886, 73, 4AB11-2 803917, 33, 4AA10-1 803918, 32, 4AA10-1 803920, 11, 7AA11-1 803922, 13, 7AA11-1 803966, 28, 10AA20-1 803974, 16, AP2054-1 803986, 2B, 8AA110-1 803991 3, 11CD31-1 30, 11CD30-1 803992, 1, 11CD30-1 803994, 2, 11CD30-1 803998, 9, 11CD30-1 804010, 23, 10AA30-1 804017, 30, 10AA30-2 804018, 28, 10AA30-2 804019, 18B, 4AA31-1 804023, 21B, 4AA31-1 804024, 26, 11CC12-1 804025, 27, 11CC12-1
--	---	---	---	---	--	---

PARTS INDEX: *Part no., Item no., Page (Drawing Ref. no.)*

CATALOG 802832, R03-04

804040, 2	804374, 7, TIER 2-1	24, 10AA10-1	B5795, 10, 5AA10-1	K302256, 21, 4AB10-1	17, 6BB10-1	2, 8AA111-1
804043, 11, 11CD30-1	804382, 12AA10-0	27, 11CD30-1	B6108, 20, 12AA10-1	K302264, 10, 7AA11-1	6, 6BB20-1	KN605815, 5, 4AA40-1
804044, 20, 6AA32-1	804383, 12AA10-0	7, 11CD31-1	B6109, 1, 12AA10-1	K33770	K34807	KN630091, 17, 4AB10-1,
804050, 28, 11CD30-1	804490, 23, TIER 2-2	B116A1-7/8, 15,	B6119, 11, 5AA10-1	5, 8AA110-1	13, 10AA30-1	4AB10.2-1
804070, 4B, 4AA20-1	804500, 9, TIER 2-1	11CC14-1	B6140, 46A, 10AE10-2	9, 8AA112-1	49, 10AE10-2	KN630174, 12, 4AA50-1
804095, 4A, 4AA20-1	804572, 19, TIER 2-1	B116A3-15, 8, 11CD30-1	B6140-1, D, 10AE11-1	K33795, 23, 10AF10-1	6, 5AA10-1	KN630360, 4, 4AA40-1
804128, 74, 4AB11-2	804592, 22, TIER 2-2	B116A3-5, 20, 11CC14-1	B6143, 25, 12AA10-1	K33797	9, 4AA30-1	KN630361, 18, 4AB10-1,
804130, 75, 4AB11-2	804600, 4, 11CD31-1	B1335, 2, 11BA30-1	B7268, 21, TIER 2-2	119, 11AA10-3,	K34807SS	4AB10.2-1
804131, 22, 3AA10-2	804662, 19, 11AB10-1	B1828, 22, 8AA105-1,	B7860, 70, 10AE10-3	11AA11-3,	16, 11AB10-1	KW501303, 1, 7AA10-1
804133L, 21, 3AA10-2	804663, 20, 11BA40-1	8AA106-1	K134, 19, 7AA11-1	11AA20-3,	9, 10AA30-1	M0000207, 15, 12AA10-1
804133R, 21, 3AA10-2	804665, 28, 11CC12-1	B1829, 23, 8AA105-1,	K20312, 19, 10AA30-1	11AA21-3	K34809, 14, 11CD30-1	M0001183
804136, B, TIER 2-1	804669, C, TIER 2-1	8AA106-1	K20344	23, 11CD30-1	K34813, 6, 6AA30-1	3, 6AA32-1
804177, 7, 11BA10-1	804670, 25, TIER 2-2	B2007, 24, 8AA105-1,	10, 4AC10-1	26, 11CD31-1	K376016, 8, 4AC11-1	43, 10AE10-2
804222, 22, 6BB21-1	804671, 18, TIER 2-1	8AA106-1	16, 11CD30-1	K33799	K40-5, 7, 4AC11-1	P3175H001, 43, 6BB11-1
804225, 23, 6BB21-1	804672, 38, TIER 2-2	B2236-15, 2AA79-0	18, 10AA20-1	26, 10AA30-1	K44719	R106, 2, 5AA10-1
804252, 1C, 8AA40-1,	804674, 36, TIER 2-2	B2236-3	19, 10AA10-1	28, 7AA11-2	26, 6BB21-1	R18147-3, 44, 10AE10-2
8AA50-1	804675, 37, TIER 2-2	11, 8AA16-1	9, 6BB21-1	K33799SS	43, 4AA10-2	R18147-5, 30, 4AA50-2
804272, 6B, 8AA40-1	804676, TIER 2-1	3, 8AA16-1	K20344SS, 132,	17, 11AB10-1	K44722	R19452, 72, 4AB11-2
804274, 8B, 8AA50-1	804677, TIER 2-1	B2236-8, 8, 4AA30-1	11AA10-3,	96, 11AA10-2,	29, 4AB12-1	R19829-1, 63, 4AB11-1
804278, 24, 6BB21-1	804776, 3A, 10AA30-1	B254-2, 111, 11AA20-3	11AA11-3,	11AA11-2,	61, 10AE10-3	R19872-6, 9, 10BA10-1
804283, 112, 11AA11-3,	804788, 9, 11CD31-1	B254-3, 35, 9AA11-1	11AA20-3,	11AA20-2	K44728	R2016, 18, 12AA10-1
11AA21-3	804804, 20, 11CD31-1	B3103, 35, TIER 2-2	11AA21-3	K33897, 125, 11AA10-3,	14, 10AA30-1	R24165-58, 35, 7AA11-2
804284, 1B, 11CD10-1	804808, 15, 11CD31-1	B3183, 13, 11AB10-1	K20348	11AA11-3,	17, 6AA30-1	R25454, 5, 5AA10-1
804285	804809, 12, 11CD31-1	B3344	10, 4AA30-1	11AA20-3,	27, 11CD31-1	R25456, 8, 5AA10-1
113, 11AA11-3,	804815, 22, 11CD31-1	1, 11BA20-1,	50, 10AE10-2	11AA21-3	K44728SS, 10, 10AA30-1	R32
11AA21-3	804819, 16, 11CD31-1	11BA30-1	K20386	K33922	K44877	10, 7AB10-1
19, 11BA30-1	804831, 26, TIER 2-2	1A, 11BA10-1	21, 11CD30-1	13, 6BB20-1	3, 8AA110-1	5, 7AA10-1
21, 6AA32-1	804832, 39, TIER 2-2	B3354-7, 1, 11AB10-1	24, 11CD31-1	18, 6BB10-1	7, 8AA112-1	R40, 43, 12AA10-1
24, 11BA20-1	804840, 17, TIER 2-1	B3500	K20386SS	K34053	K45805, 7, 6AA30-1	R4584, 3, 5AA10-1
804287	804886, 23, 11CD31-1	20, 6BB20-1	14, 6BB20-1	19, 11CD30-1	K45860, 8, 6AA30-1	R7638, 4, 5AA10-1
115, 11AA11-3,	8081, 10, TIER 2-1	3, 4AC11-1	16, 6BB10-1	4, 10AA30-1	K54089SS, 6, 10AA30-1	T51534
11AA21-3	81044	B3698-17, 47, 4AB10.2-2	K20388	K34079, 8, 6BB21-1	K54351SS, 18, 11CD30-1	5, 7AA11-1
14, 11BA40-1	23, 6BB10-1	B3698-2	27, 10AA30-1	K34691	K55691	9, 6AA30-1
15, 11CD30-1	29, 6BB20-2	17, 11BA30-1	7, 5AA10-1	1, 6AA20-1	30, 4AB12-1	U43217-10110-71, 41,
20, 11BA30-1	81047	20, 11BA20-1	K20388SS	7, 6AA31-1	62, 10AE10-3	6BB10-2
22, 11CC14-1	15, 6BB10-1	B3698-21, 60, 10AE10-3	15, 11AB10-1	K34779	K55748, 17, 10AA30-1	Z2805-34, 1A, 4AC11-1
23, 11BA20-1	9, 6BB20-1	B3698-25, 12, 10AA30-1	8, 10AA30-1	13, 6BB21-1	K58758, 8, 6AA31-1	Z2805-62, 1B, 4AC11-1
25, 11CC12-1	84307, 45, 11AA20-1,	B4712	K20424	20, 11CD30-1	K71B1393, 71, 10AE10-3	Z2880-40, 49, 12AA10-1
8, 11BA10-1	11AA21-1	20, 10AF10-1	3, 6BB21-1	K34791	K8-326	Z4053, 6, 8AA123-1,
804288	86506	38, 12AA10-1	45, 4AA10-2	17, 10AA20-1	14, 10AA20-1	8AA124-1
114, 11AA11-3,	28, 4AB12-1	B5407, 9, 5AA10-1	K20428	18, 10AA10-1	15, 10AA10-1	Z4053-10, 42, 9AA10-1
11AA21-3	60, 11AA10-2,	B5425, 48, 10AE10-2	16, 6AA30-1,	4, 8AA110-1	K87550, 5, 4AC11-1	Z4054-27, 12, 9AA11-1
18, 11AB10-1	11AA11-2,	B5505-1	10AA30-1	8, 8AA112-1	K87901	Z4054-27.63, 5B,
804290, 110, 11AA11-3,	11AA20-2,	54A, 10AE10-3	59, 10AE10-3	K34805	1, 5AA10-1	4AA31-1
11AA21-3	11AA21-2	A, 10AE11-1	K217-8, 17, 11CD31-1	17, 11CD30-1	31A, 7AA11-2	Z4054-4.5, 20B, 4AA31-1
804295, 5C, 8AA30-1	86832, 34, 7AA11-2	B5505-2	K224-6	22, 10AF10-1	K87914, 31B, 7AA11-2	Z4056
804312, 134, 11AA11-3,	89179, 29, 7AA11-2	54B, 10AE10-3	26, 11CD30-1	44, 4AA10-2	K89778, 7, 6BB20-1	4, 8AA123-1,
11AA21-3	B103A1, 4, 4AC11-1	B, 10AE11-1	6, 11CD31-1	5, 6BB21-1	K97524, 16, 6BB20-1	8AA124-1
804326, 4B, 9AA10-1	B104A4, 28, 11CD31-1	B5505-3	K225-6, 13, 11CC14-1	K34805SS, 9, 4AC10-1	K97615, 6, 4AB10A-1	5, 8AA123-1,
804327, 5B, 9AA10-1	B1074, 11, 6BB21-1	54C, 10AE10-3	K300858	K34806	KN605557, 13, 11CD30-1	8AA124-1
804338, 34, 4AA10-1	B109A34, 6, 11CD30-1	C, 10AE11-1	21, 10AF10-1	22, 11CD30-1	KN605803	Z4525-24, 72, 10AE10-3
804339, 42, 4AA10-2	B110A8, 25, 10AA30-1	B5515, 47, 10AE10-2	25, 6BB21-1	25, 11CD31-1	1, 4AA20-1	Z4525-5, 68, 4AB10-2
804369, 12AA10-0	B114A3	B5764, 21, 11CC14-1	K302211, 21, 4AB10.2-1	K34806SS	13, 4AA50-1	Z5010 x 31, 4AB10.5-0
804373, 20, TIER 2-1						