



MANITOU NORTH AMERICA, INC.

6401 IMPERIAL DRIVE
Waco, TX 76712-6803

NOTE: *Manitou Forklift Manuals are continually updated and subject to change without prior notice. If your Forklift Model or parts are not found in this manual, please contact your dealer or the Manitou North America Parts Department for the latest information and parts availability.*

S/N: 756587
S/N: 757730 & 757731, 757733 thru 757742
S/N: 758315, 758320 & above

M30/40/50-2T H/L
M30/40/50-4T H/L

**HYDROSTATIC & 4-SPEED
TRANSMISSIONS
- TIER III ENGINE -**

PARTS MANUAL

For Parts Orders contact your Manitou North America Dealer or call:
Manitou North America, Parts Dept. 800-425-3727 or (254) 799-0232
Parts Dept. Fax: (254) 867-6504 Email: parts.mna@manitou.com

**M-SERIES TIER III
FORKLIFT MODEL DESCRIPTION**

**TIER III MODELS ARE READILY IDENTIFIED BY THE SILVER COLORED
WHEELS, BLACK FRONT/REAR AXLES AND TURBO LOGO ON THE TANKS**

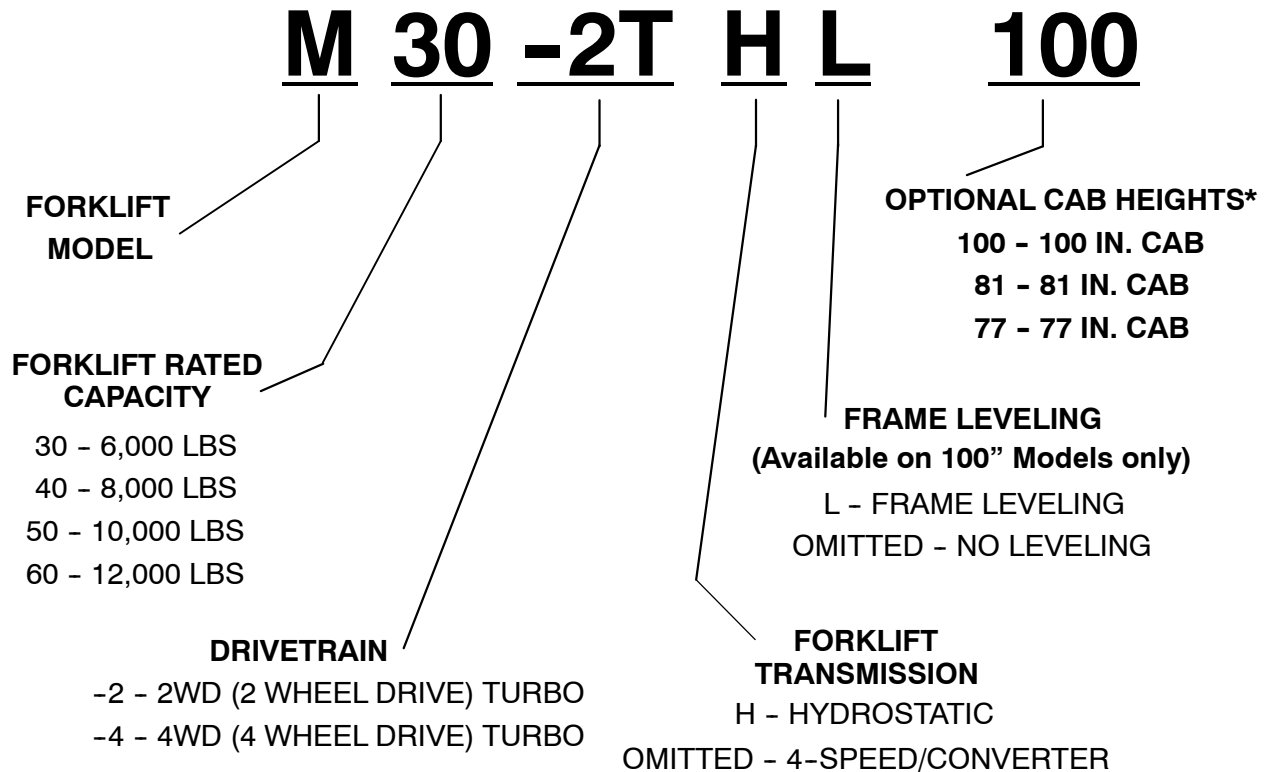

* Dimensions may vary depending on tires, additional options, etc.

M - S E R I E S T I E R I I I
P O W E R T R A I N C O M P O N E N T
I D E N T I F I C A T I O N

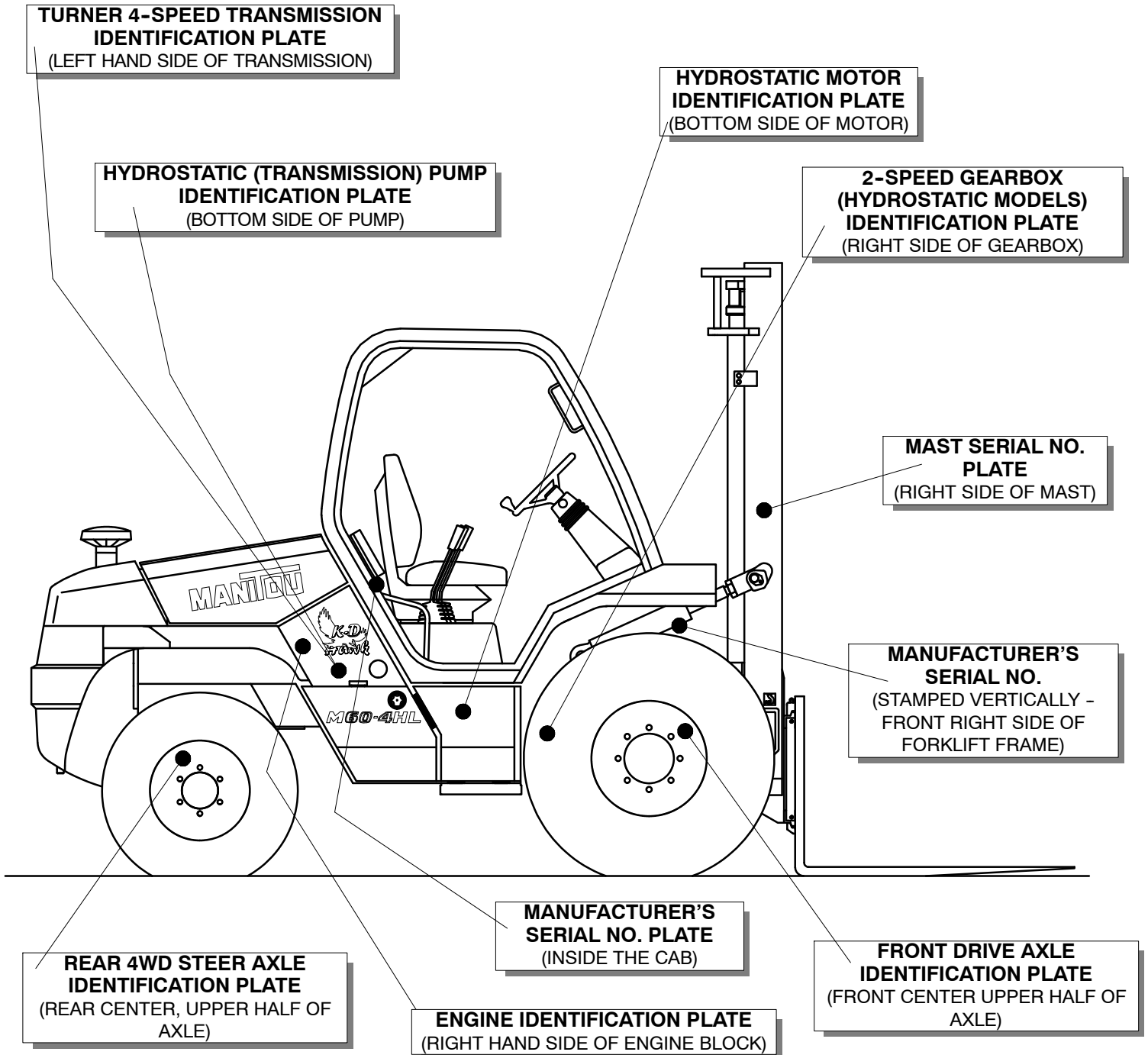

GENERAL INFORMATION

The purpose of this catalog is to provide illustrations for identifying and ordering assorted forklift parts. The illustrations provide a general description and may not show the *exact* shape or detail of the parts or components represented.

The parts are identified by an Item number on the Illustration Page. Find the Item Number for the part desired, then locate that Item Number under the "Items" column on the parts page. The part number will be located directly to the right of the Item Number. Also provided is a part description, dimensions (where necessary), quantity of parts required and the Truck Model Identification.

Manitou North America, Inc. continues to improve product design as new technologies are developed, and reserves the right to make revisions without prior notice. Please contact your nearest dealer or the Manitou North America Parts Dept. if you have any questions.

When ordering parts or requesting technical information, the following numbers are required:

Truck Model No: _____

Serial No: _____

Mast Model No: _____

Serial No: _____

Engine Name (Cat or Perkins): _____

Engine (List) No: _____

Transmission (Hydrostatic or 4-Speed): _____

Model (MANITOU) reference: _____

Serial No: _____

Hydrostatic Motor (Hydrostatic Models only): _____

Model No: _____

Serial No: _____

2-Speed Gearbox Model No. (Hydrostatic Models only): _____

Serial No: _____

Front Drive Axle No: _____

MANITOU reference: _____

Serial No: _____

Rear Drive Axle No. (4WD only): _____

MANITOU reference: _____

Serial No: _____

Attachment Model No: _____

Serial No: _____

For quick reference it is recommended these numbers be recorded as soon as possible.

<p style="text-align: center;">2 AA 163</p> <p style="text-align: right;">1.00</p>	<p style="text-align: center;">3 AA 245</p> <p style="text-align: right;">2.00</p>	<p style="text-align: center;">3 AA 246</p> <p style="text-align: right;">3.00</p>
<p style="text-align: center;">4 AA 601</p> <p style="text-align: right;">4.00</p>	<p style="text-align: center;">4 AA 602</p> <p style="text-align: right;">5.00</p>	<p style="text-align: center;">4 AA 603</p> <p style="text-align: right;">6.00</p>
<p style="text-align: center;">4 AA 604</p> <p style="text-align: right;">7.00</p>		

<p>4 AA 605</p> <p>VIEW A</p> <p>APPLY THREAD SEALANT TO ENGINE BLOCK BOLTS TORQUE TO 77 IN-LB</p> <p>2 RH SHOWN 3 LH</p> <p>8.00</p>	<p>4 AA 606 4-SPEED</p> <p>USE A RUBBER Mallet TO SEAL BEACH INTO PLUG</p> <p>4-4 NO ONLY REMOVE THIS PLUG AND REPLACE WITH TRK 30 & 33</p> <p>VIEW A</p> <p>VIEW B</p> <p>VIEW 3</p> <p>* - APPLY LUBRIC 342</p> <p>9.00</p>	<p>4 AA 627 4-SPEED</p> <p>USE A RUBBER Mallet TO SEAL BEACH INTO PLUG</p> <p>VIEW A</p> <p>VIEW B</p> <p>10.00</p>
<p>4 AB 149 HYDROSTATIC</p> <p>NOTE: FOR GEARBOX BREATHER VALVE, HYDROSTATIC PUMP AND MOTOR FITTINGS. SEE 4AB151</p> <p>11.00</p>	<p>4 AB 151 HYDROSTATIC</p> <p>12.00</p>	<p>4 AB 152 HYDROSTATIC</p> <p>13.00</p>
<p>4 AC 223</p> <p>14.00</p>		

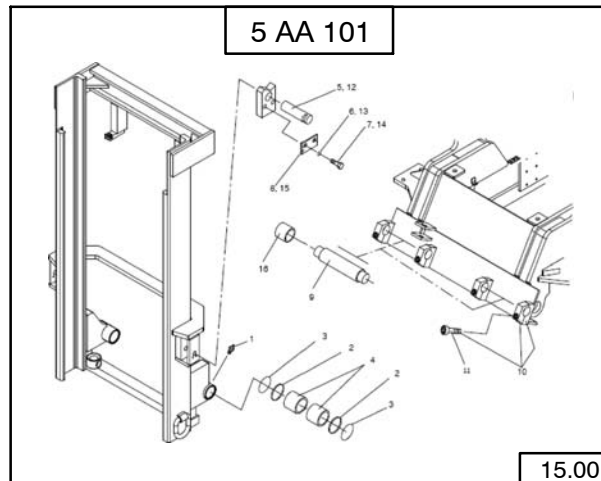

15.00

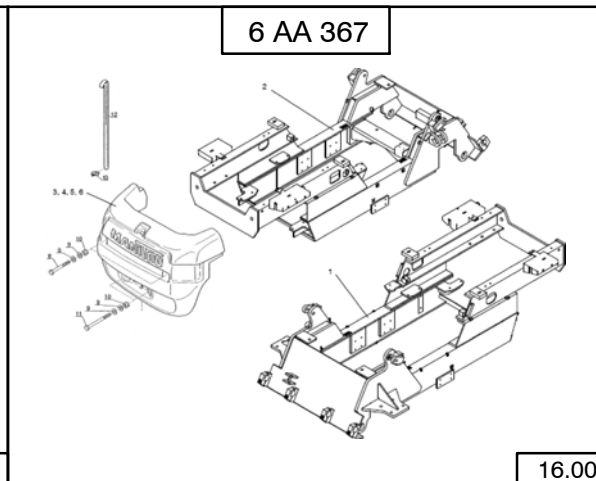

16.00

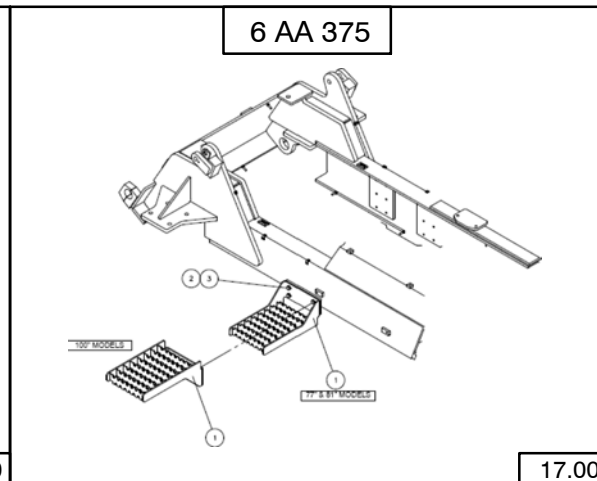

17.00

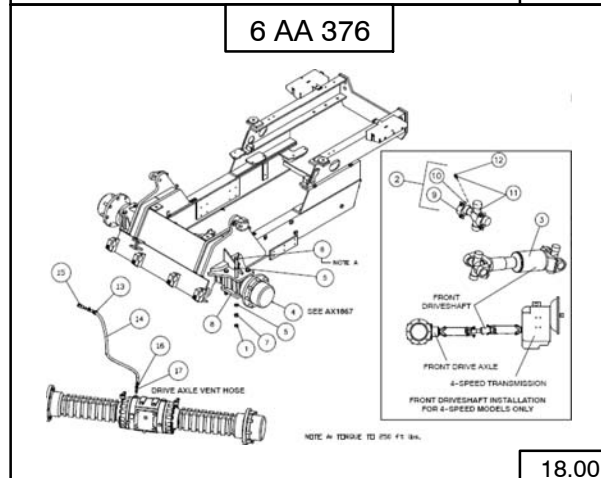

18.00

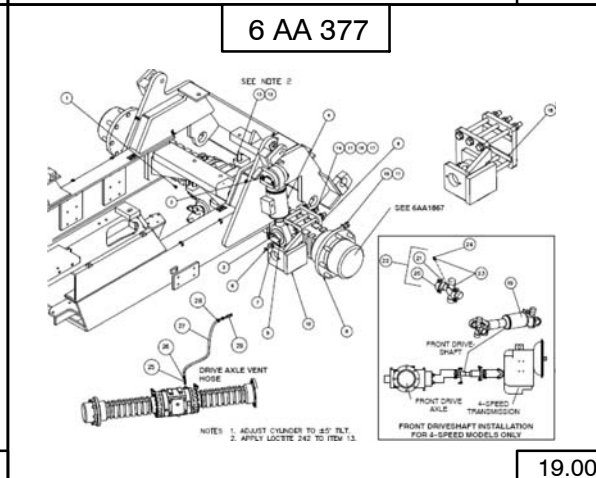

19.00

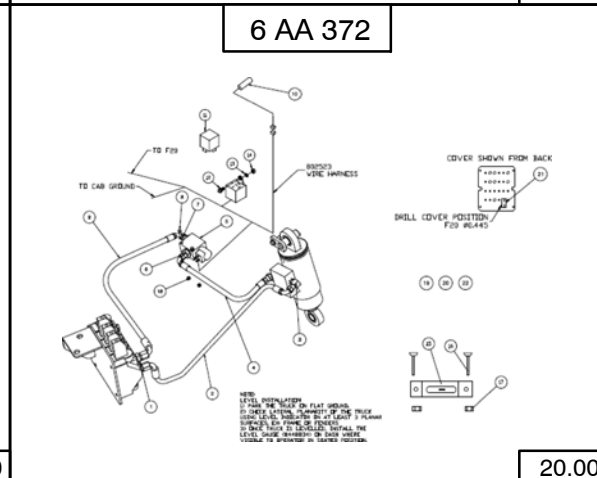

20.00

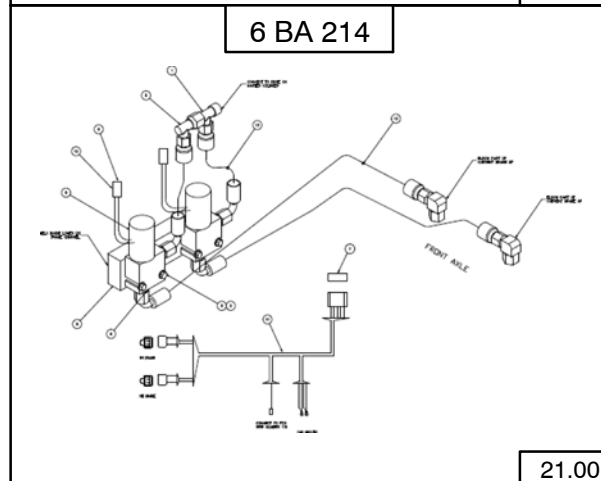

21.00

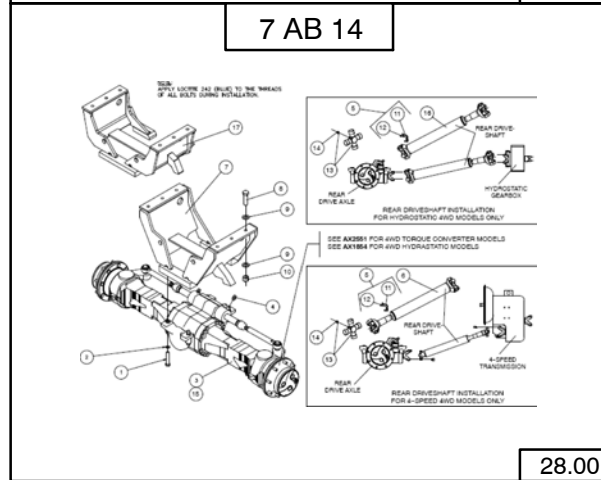
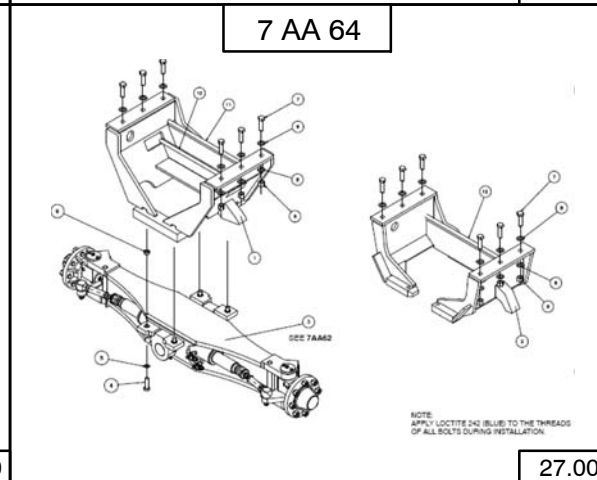
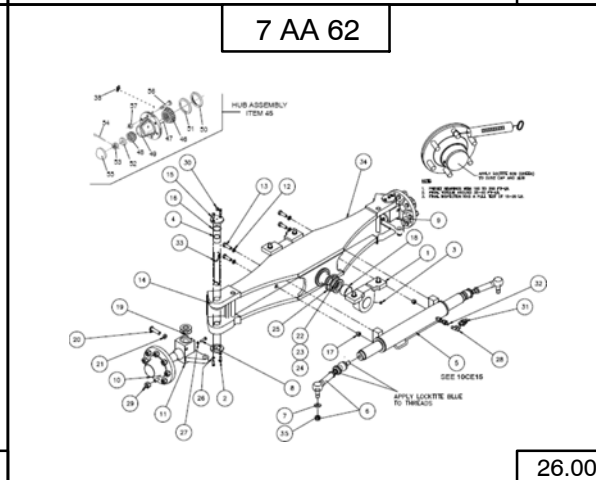
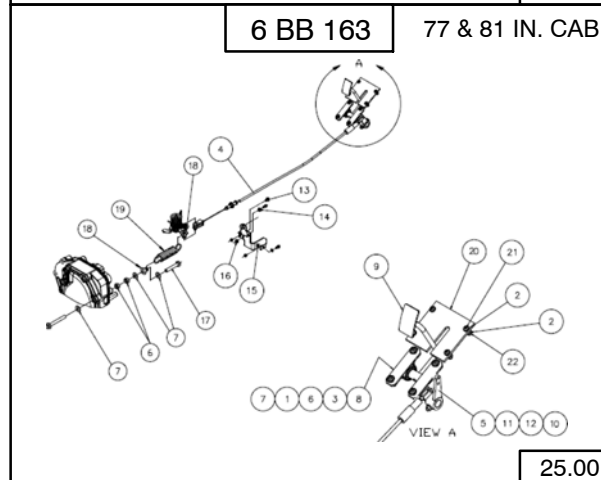
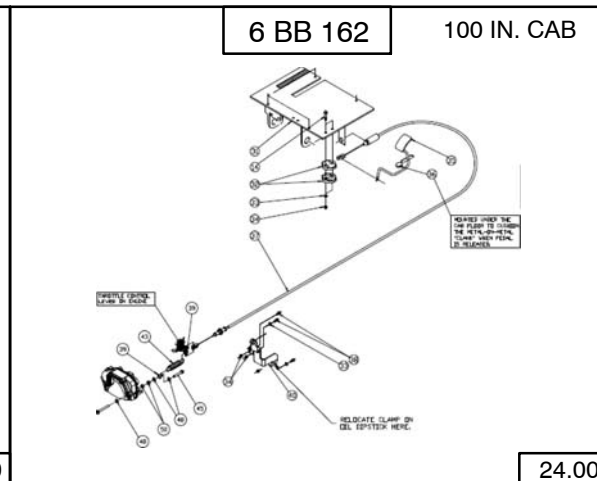
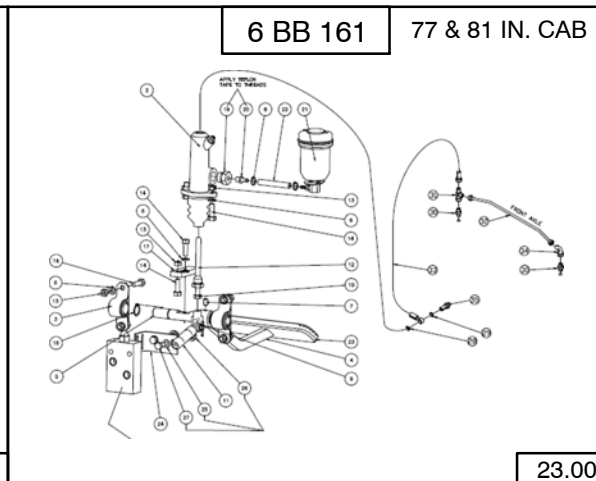
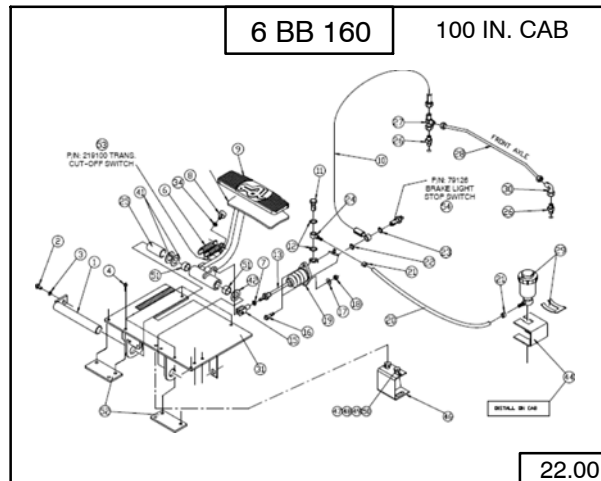

INDEX

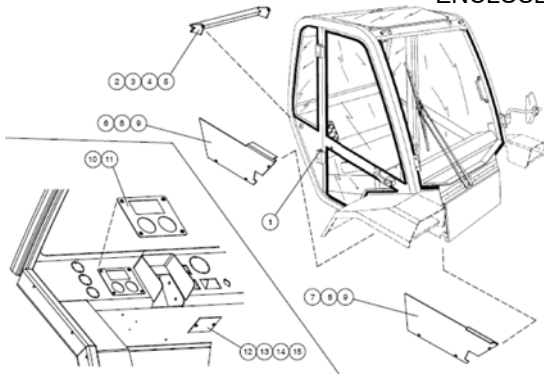
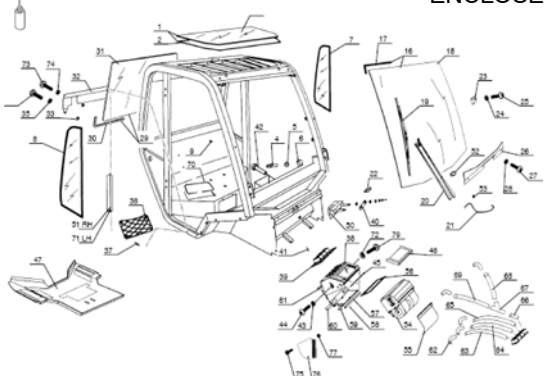
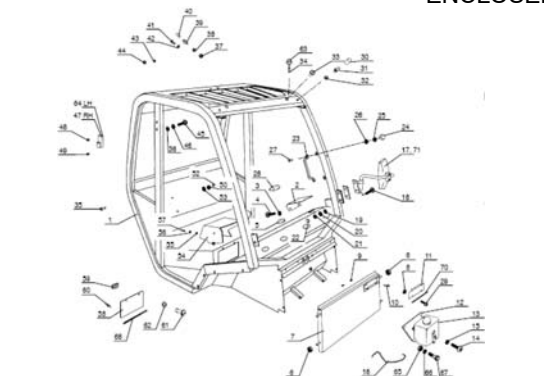
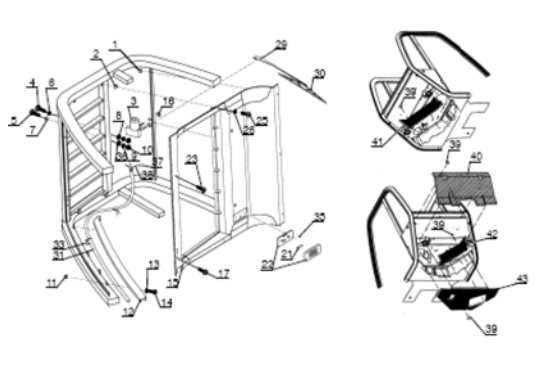
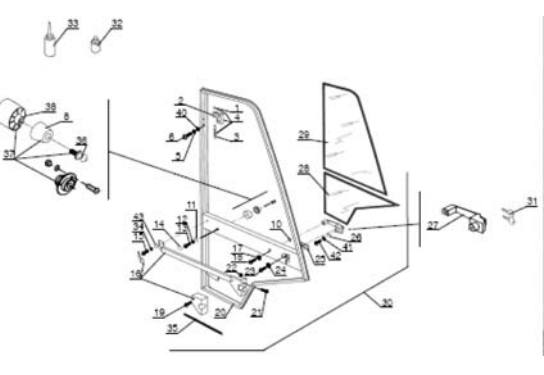
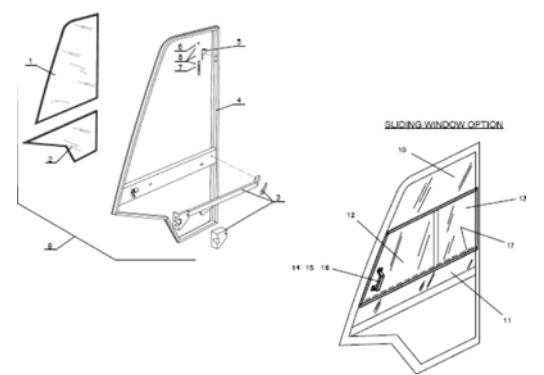
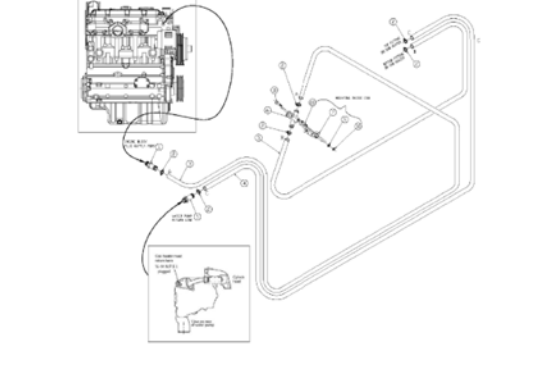
<p>8 AA 462 100 IN. CAB ENCLOSED</p>  <p style="text-align: right;">29.00</p>	<p>8 AA 463 100 IN. CAB ENCLOSED</p>  <p style="text-align: right;">30.00</p>	<p>8 AA 464 100 IN. CAB ENCLOSED</p>  <p style="text-align: right;">31.00</p>
<p>8 AA 465 100 IN. CAB ENCLOSED</p>  <p style="text-align: right;">32.00</p>	<p>8 AA 466 100 IN. CAB ENCLOSED</p>  <p style="text-align: right;">33.00</p>	<p>8 AA 467 100 IN. CAB ENCLOSED</p>  <p style="text-align: right;">34.00</p>
<p>8 AA 468 100 IN. CAB ENCLOSED</p>  <p style="text-align: right;">35.00</p>	<p style="text-align: center;">[Empty Box]</p>	<p style="text-align: center;">[Empty Box]</p>

<p>8 AA 504 100 IN. CAB OPEN</p> <p style="text-align: right;">36.00</p>	<p>8 AA 663 77 & 81 IN. CAB OPEN 4-SPEED</p> <p style="text-align: right;">37.00</p>	<p>8 AA 664 77 & 81 IN. CAB OPEN HYDROSTATIC</p> <p style="text-align: right;">38.00</p>
<p>8 AA 472</p> <p style="text-align: right;">39.00</p>	<p>8 AA 473 100 IN. CAB ENCLOSED SEMI-ENCLOSED</p> <p style="text-align: right;">40.00</p>	<p>8 AA 474 100 IN. CAB OPEN</p> <p style="text-align: right;">41.00</p>
<p>8 AA 475 77 & 81 IN. CAB</p> <p style="text-align: right;">42.00</p>	<p style="text-align: center;">[Empty Box]</p>	<p style="text-align: center;">[Empty Box]</p>

I N D E X

<p>8 AA 476 100 IN.CAB ENCLOSED SEMI-ENCLOSED</p> <p>43.00</p>	<p>8 AA 479 100 IN. CAB</p> <p>44.00</p>	<p>8 AA 480 77 & 81 IN.CAB</p> <p>45.00</p>
<p>8 AA 481 77 & 81 IN.CAB</p> <p>46.00</p>	<p>8 AA 482 100 IN.CAB</p> <p>47.00</p>	<p>8 AA 483 77 & 81 IN. CAB</p> <p>48.00</p>
<p>8 AA 665 100 IN.CAB OPEN</p> <p>49.00</p>		

8 AA 485 77 & 81 IN. CAB OPEN

50.00

8 AA 322

51.00

9 AA 323

52.00

10 AA 633 4-SPEED

53.00

NOTES:
 1. APPLY LOCTITE GAS THREAD SEALER TO WARE THREAD.
 2. O-RING SEAL SUPPLIED WITH LEVER SHAFT.

10 AA 634 HYDROSTATIC

54.00

NOTES:
 1. APPLY LOCTITE GAS THREAD SEALER TO WARE THREAD.
 2. O-RING SEAL SUPPLIED USE FROM "A"
 WITH A. REPAIR KITS FOR SPN 1000-0700.

10 AA 635

55.00

MOUNTS TO BRACKETS ON FORKARMS

SEE DETAIL "A"

10 AA 636

56.00

10 AE 736

57.00

10 AE 737

58.00

10 AE 762

59.00

10 AF 592

60.00

10 BA 302

61.00

10 CE 15

62.00

10 DA 318

63.00

10 DA 320

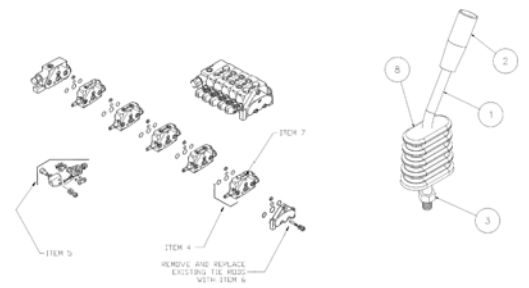

64.00

11 AA 1035

4-SPEED

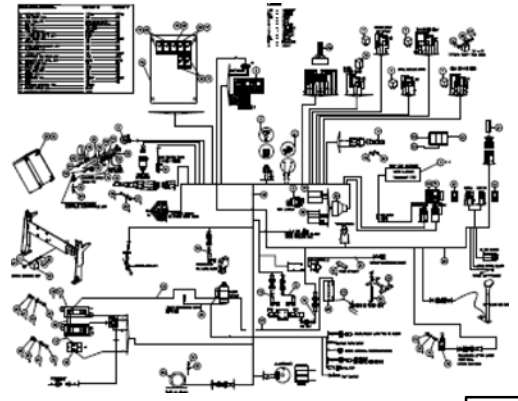

65.00

11 AA 1036

HYDROSTATIC

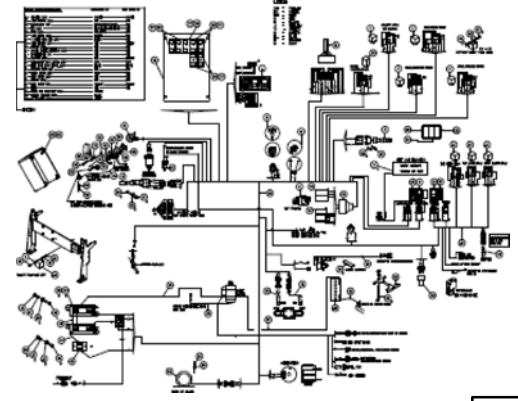

66.00

11 BA 103

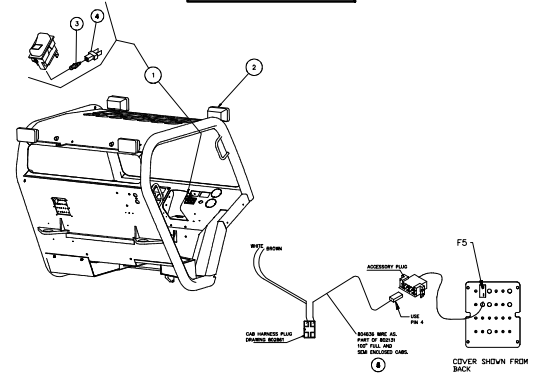

67.00

11 BA 119

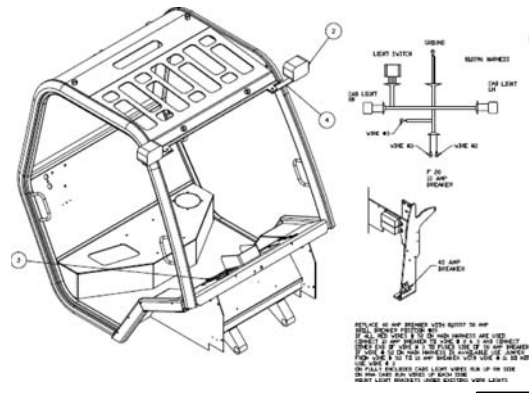

68.00

11 BA 120

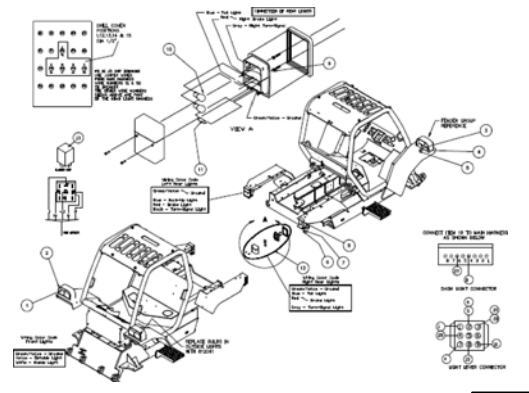

69.00

11 BA 121

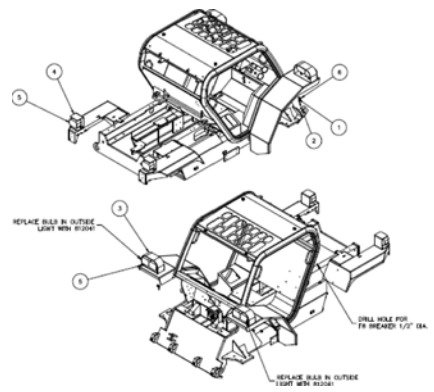

70.00

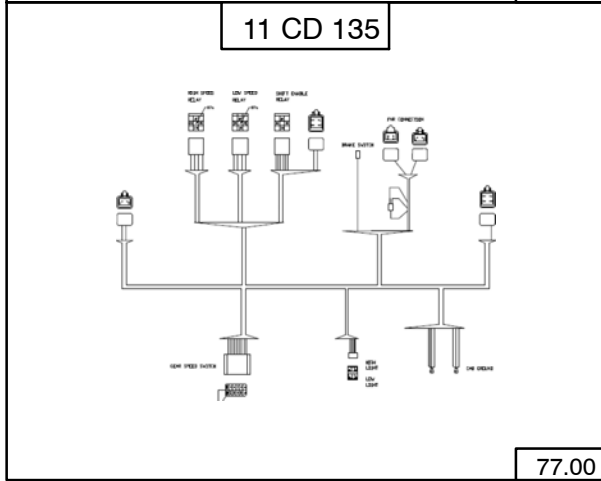
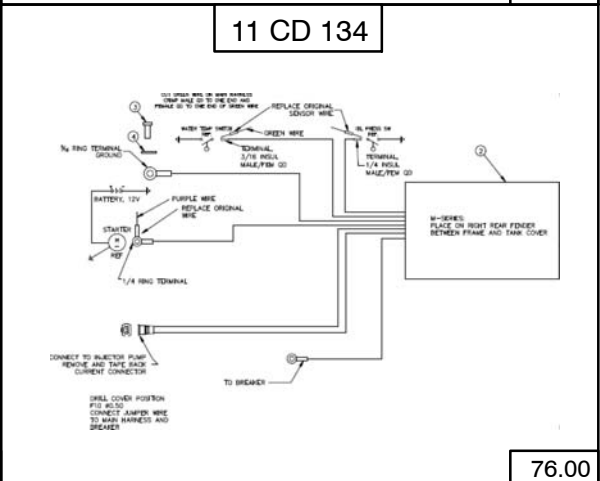
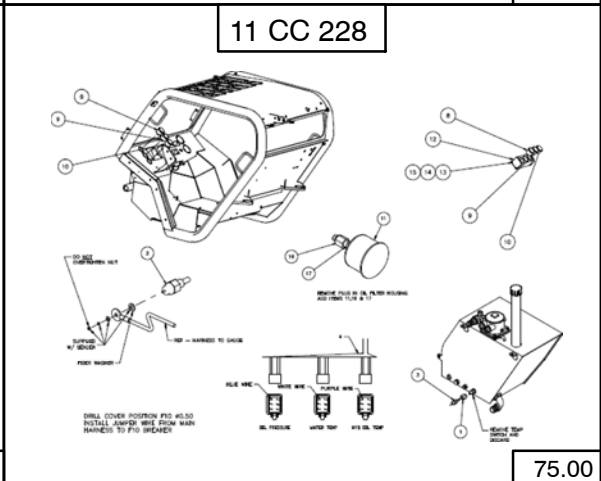
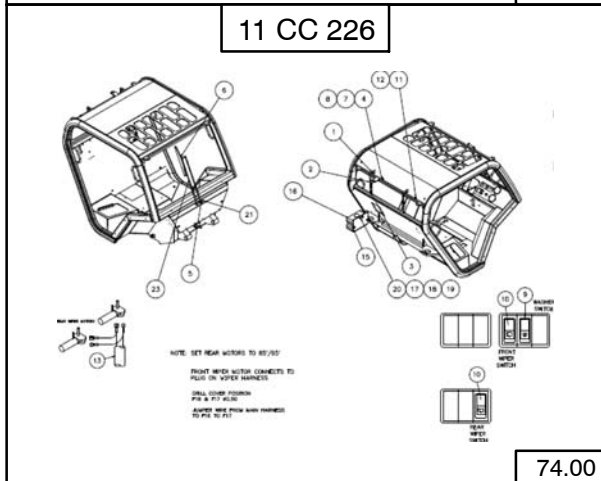
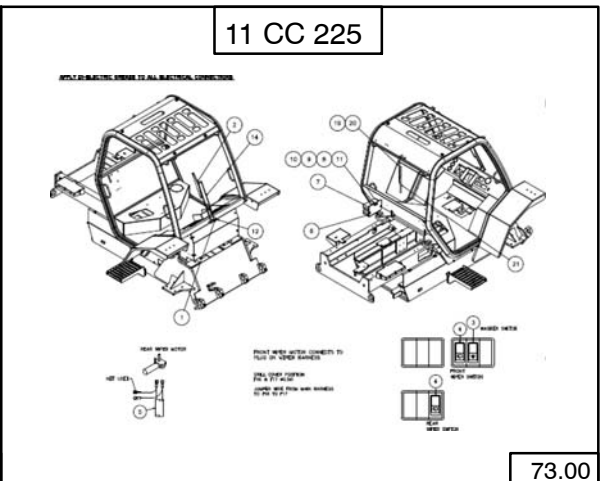
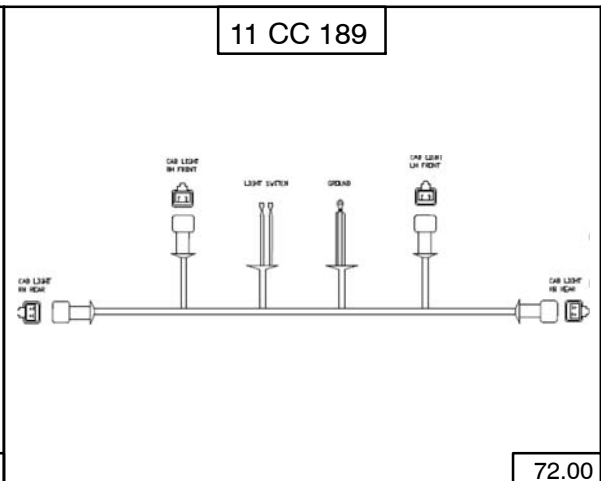
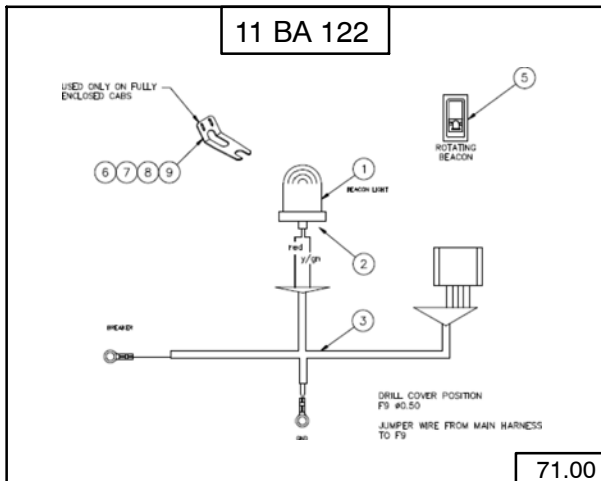

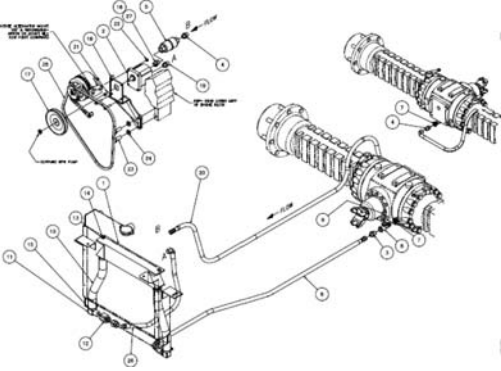
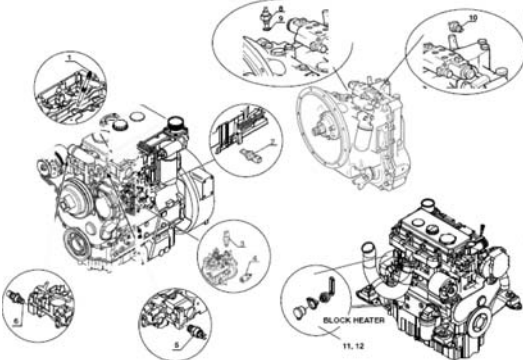
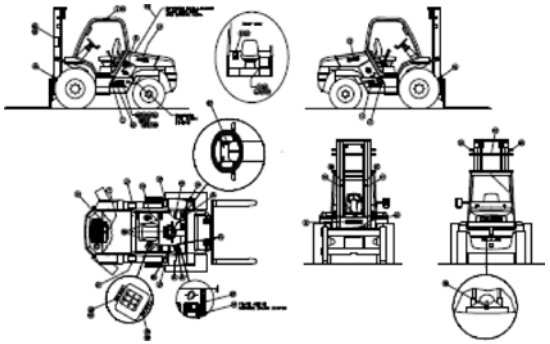
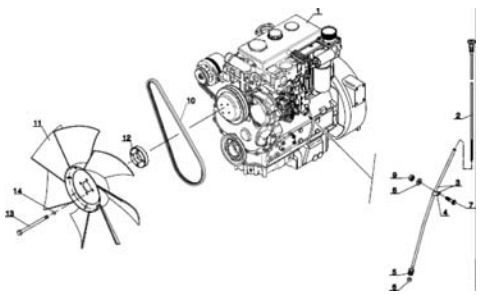
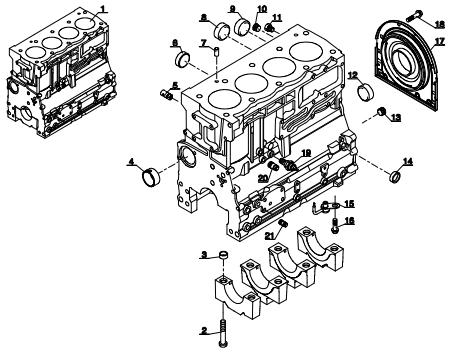
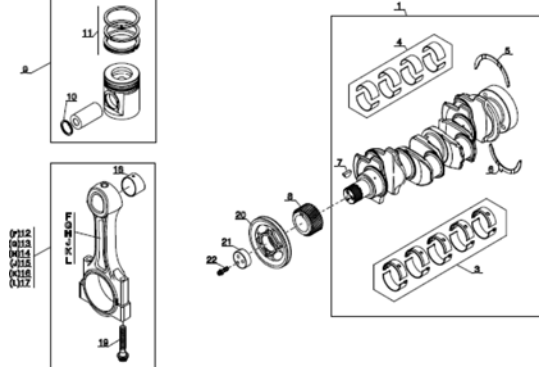
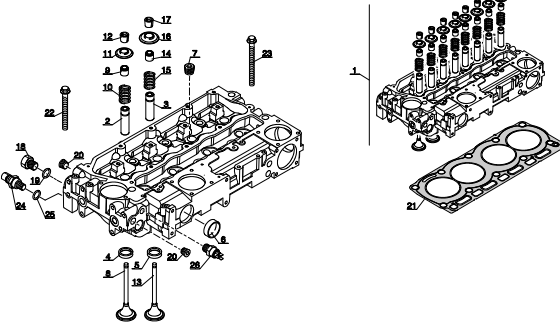
<p>11 CD 129</p>  <p>78.00</p>	<p>11 CD 161</p>  <p>79.00</p>	<p>12 AA 463 DECALS</p>  <p>80.00</p>
<p>AP 1844</p>  <p>81.00</p>	<p>AP 1950 PERKINS</p>  <p>82.00</p>	<p>AP 1951 PERKINS</p>  <p>83.00</p>
<p>AP 1952 PERKINS</p>  <p>84.00</p>	<p></p>	<p></p>

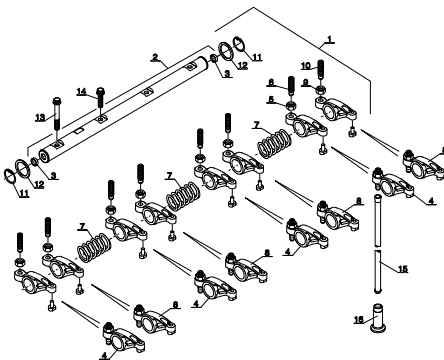
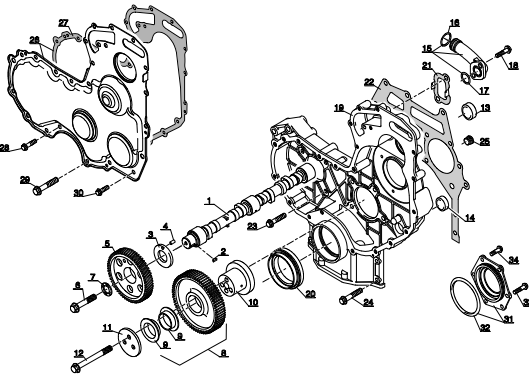
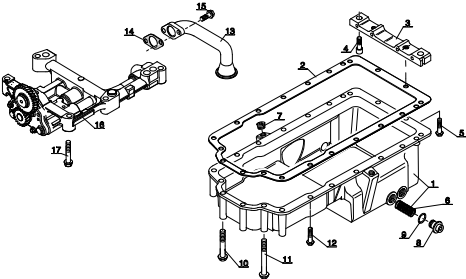
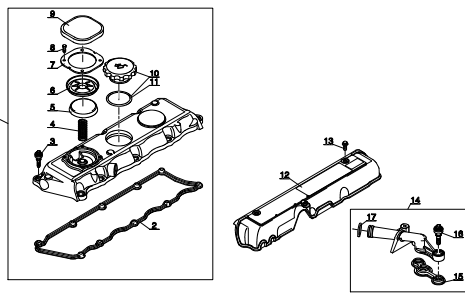
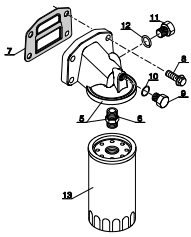
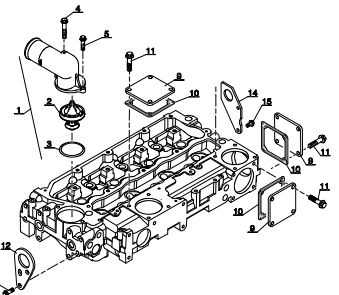
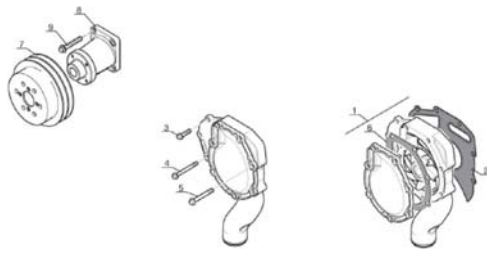
<p style="text-align: center;">AP 1953 PERKINS</p>  <p style="text-align: right;">85.00</p>	<p style="text-align: center;">AP 1954 PERKINS</p>  <p style="text-align: right;">86.00</p>	<p style="text-align: center;">AP 1955 PERKINS</p>  <p style="text-align: right;">87.00</p>
<p style="text-align: center;">AP 1956 PERKINS</p>  <p style="text-align: right;">88.00</p>	<p style="text-align: center;">AP 1957 PERKINS</p>  <p style="text-align: right;">89.00</p>	<p style="text-align: center;">AP 1958 PERKINS</p>  <p style="text-align: right;">90.00</p>
<p style="text-align: center;">AP 1959 PERKINS</p>  <p style="text-align: right;">91.00</p>	<p style="text-align: center;">[Empty]</p>	<p style="text-align: center;">[Empty]</p>

I
N
D
E
X

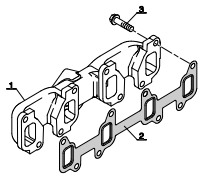
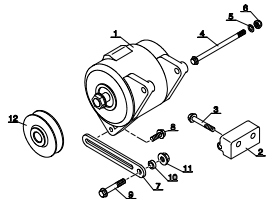
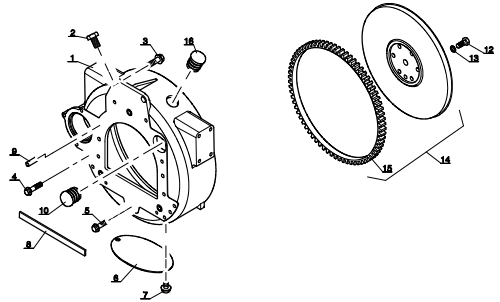
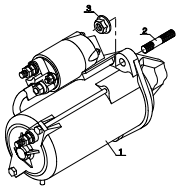
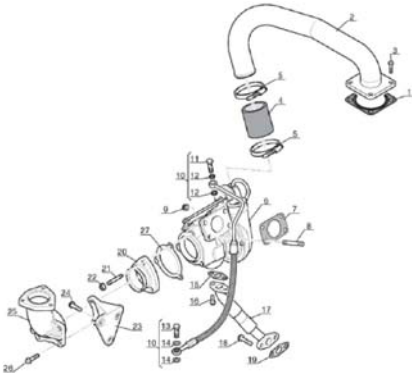
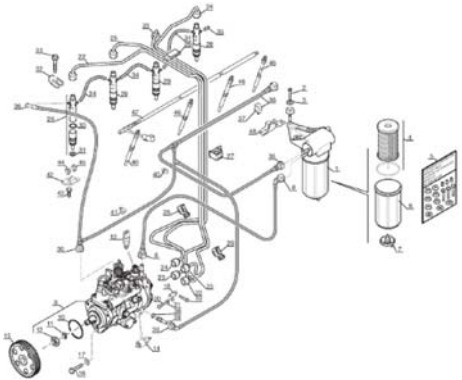
<p>AP 1960 PERKINS</p>  <p>92.00</p>	<p>AP 1961 PERKINS</p>  <p>93.00</p>	<p>AP 1962 PERKINS</p>  <p>94.00</p>
<p>AP 1963 PERKINS</p>  <p>95.00</p>	<p>AP 1964 PERKINS</p>  <p>96.00</p>	<p>AP 1965 PERKINS</p>  <p>97.00</p>
<p></p>	<p></p>	<p></p>

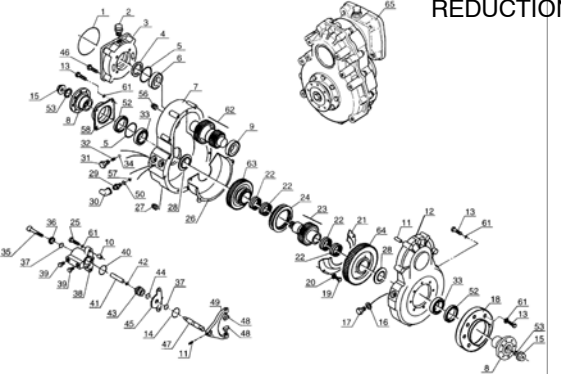
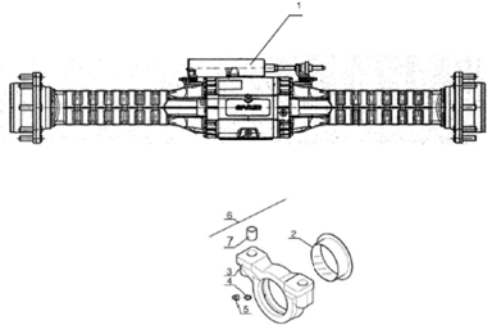
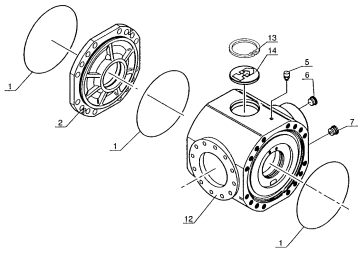
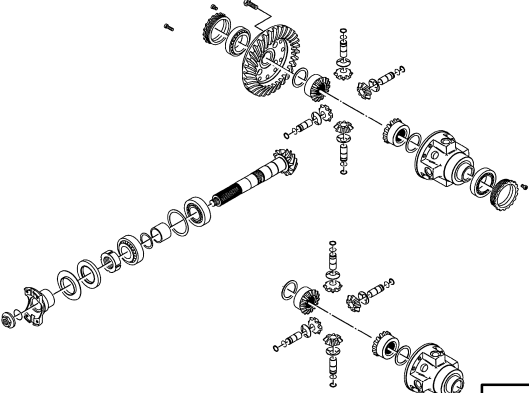
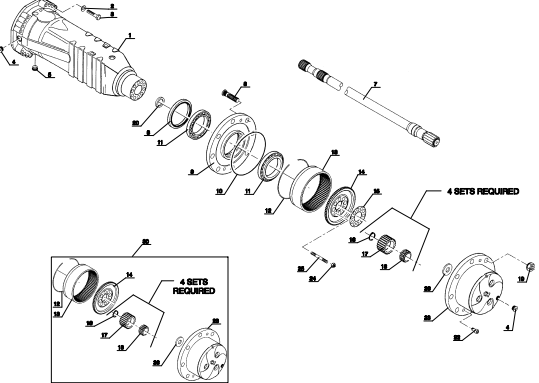
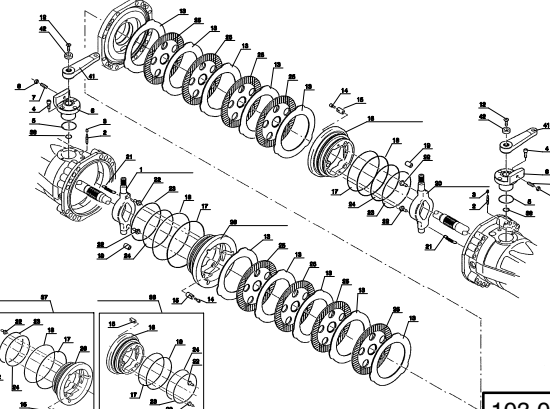
<p>AX 1851 GEARBOX, 2-SPEED REDUCTION</p>  <p style="text-align: right;">98.00</p>	<p>AX 1867 FRONT AXLE</p>  <p style="text-align: right;">99.00</p>	<p>AX 1868 FRONT AXLE</p>  <p style="text-align: right;">100.00</p>
<p>AX 1449 FRONT AXLE</p>  <p style="text-align: right;">101.00</p>	<p>AX 1450 FRONT AXLE</p>  <p style="text-align: right;">102.00</p>	<p>AX 1415 FRONT AXLE</p>  <p style="text-align: right;">103.00</p>
<div style="border: 1px solid black; height: 20px; width: 100%;"></div>	<div style="border: 1px solid black; height: 20px; width: 100%;"></div>	<div style="border: 1px solid black; height: 20px; width: 100%;"></div>

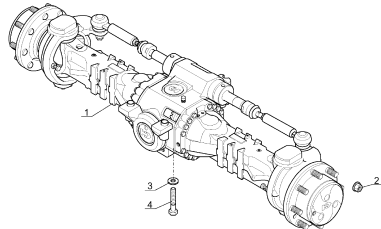
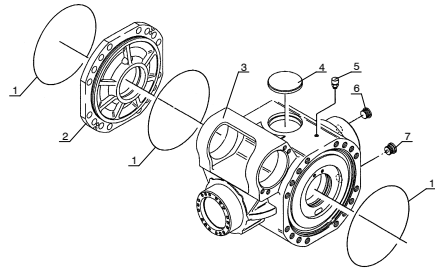
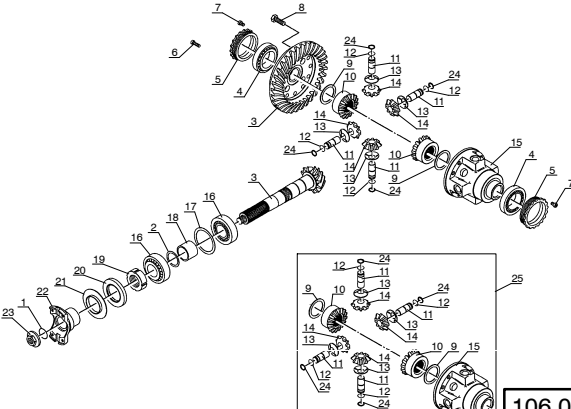
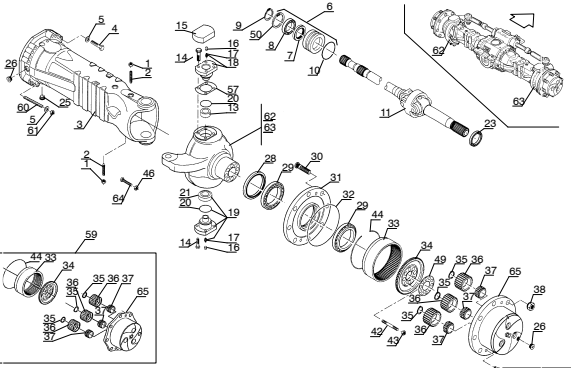
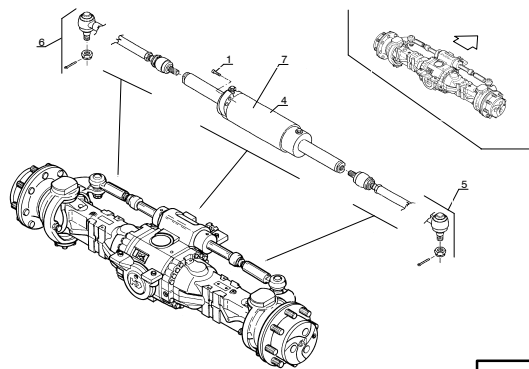
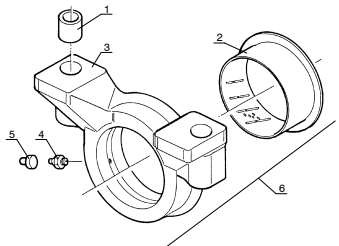
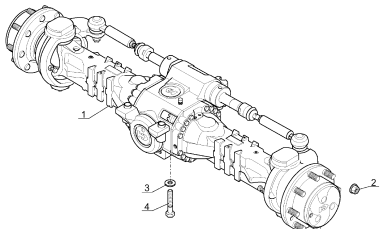
<p style="text-align: center;">AX 2551 REAR AXLE TC 4WD</p>  <p style="text-align: right;">104.00</p>	<p style="text-align: center;">AX 1580 REAR AXLE TC 4WD</p>  <p style="text-align: right;">105.00</p>	<p style="text-align: center;">AX 1581 REAR AXLE TC 4WD</p>  <p style="text-align: right;">106.00</p>
<p style="text-align: center;">AX 1582 REAR AXLE TC 4WD</p>  <p style="text-align: right;">107.00</p>	<p style="text-align: center;">AX 1583 REAR AXLE TC 4WD</p>  <p style="text-align: right;">108.00</p>	<p style="text-align: center;">AX 1584 REAR AXLE TC & HYDRO 4WD</p>  <p style="text-align: right;">109.00</p>
<p style="text-align: center;">AX 1854 REAR AXLE HYDRA 4WD</p>  <p style="text-align: right;">110.00</p>	<p style="text-align: center;">[Empty Box]</p>	<p style="text-align: center;">[Empty Box]</p>

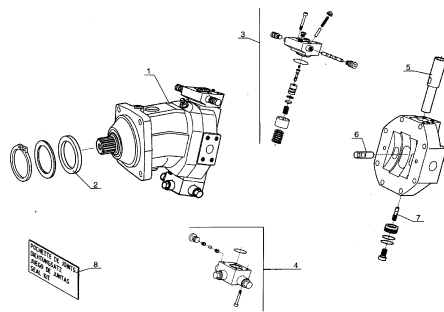
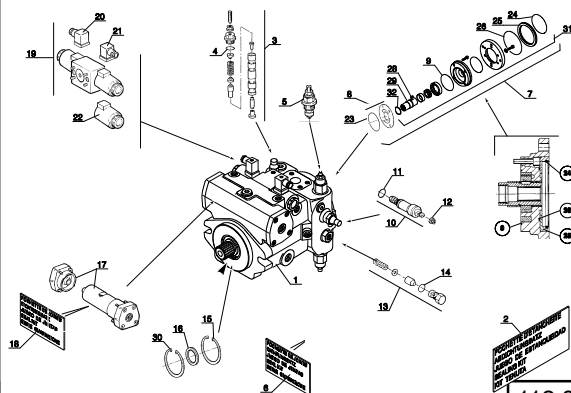
<p>BC 108 HYDROSTATIC</p>  <p>111.00</p>	<p>BC 154 HYDROSTATIC</p>  <p>112.00</p>	

<p style="text-align: center;">BP 177 4-SPEED, 2WD</p> <p style="text-align: right;">113.00</p>	<p style="text-align: center;">BP 178 4-SPEED, 2WD</p> <p style="text-align: right;">114.00</p>	<p style="text-align: center;">BP 76 4-SPEED, 2WD</p> <p style="text-align: right;">115.00</p>
<p style="text-align: center;">BP 203 4-SPEED, 2WD</p> <p style="text-align: right;">116.00</p>	<p style="text-align: center;">BP 181 4-SPEED, 2/4WD</p> <p style="text-align: right;">117.00</p>	<p style="text-align: center;">BP 182 4-SPEED, 4WD</p> <p style="text-align: right;">118.00</p>
<p style="text-align: center;">BP 183 4-SPEED, 4WD</p> <p style="text-align: right;">119.00</p>	<p style="text-align: center;"> </p>	<p style="text-align: center;"> </p>

2 AA 163

TIER III

FILTERS AND BELTS

M30-2T M40-2T M50-2T	M30-4T M40-4T M50-4T	M30-2T H M40-2T H M50-2T H	M30-4T H M40-4T H M50-4T H
M30-2T L M40-2T L M50-2T L	M30-4T L M40-4T L M50-4T L	M30-2T H L M40-2T H L M50-2T H L	M30-4T H L M40-4T H L M50-4T H L

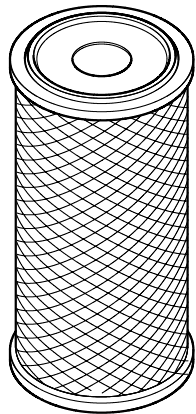

Air filter cartridge
563416 MANITOU - Plastic Canister
803655 NELSON - Steel Canister

706497
Filter

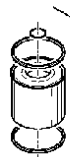

747027
Glass bowl

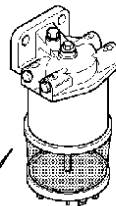

254561
Water/fuel separator

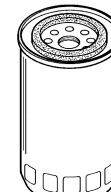

561749
Transmission oil filter
(4-speed transmission)

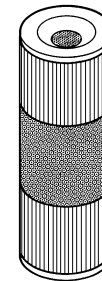

221174 (4-speed)
Hydraulic return oil filter
602096 (Hydrostatic)
Hydraulic return oil filter

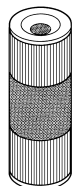

Cat or Perkins
Engine fuel filter
605013

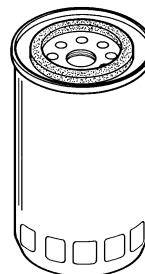

476954
Engine oil filter
Cat or Perkins

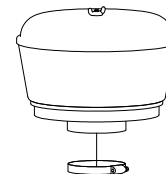

803071
Air Intake Pre-filter
B2236-15 clamp

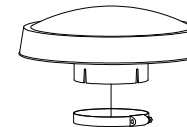

508565
Rain Cap Pre-filter
& clamp
470680 clamp



425501
Filter cap for
hydraulic oil tank

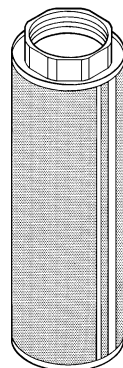

424764
Suction strainer
(inside hydraulic oil tank)

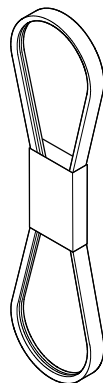

702494
Fan belt, alternator

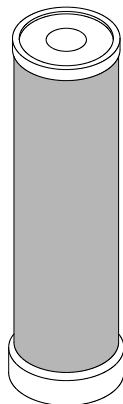

Safety air filter cartridge
563415 MANITOU
803654 NELSON

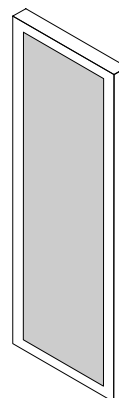

562185
Cab vent filter
(100 in. enclosed cab)



813120
Turbo II Engine
pre-filter & clamp

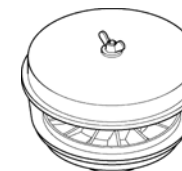

224713
Cyclonic Engine
pre-filter & clamp



B169
Fuel cap for
diesel fuel tank

3 AA 245

TIRES AND WHEELS, FRONT

TIER III

M30-2T	M30-4T	M30-2T H	M30-4T H
M40-2T	M40-4T	M40-2T H	M40-4T H
M50-2T	M50-4T	M50-2T H	M50-4T H
M30-2T L	M30-4T L	M30-2T H L	M30-4T H L
M40-2T L	M40-4T L	M40-2T H L	M40-4T H L
M50-2T L	M50-4T L	M50-2T H L	M50-4T H L

TITAN TREAD

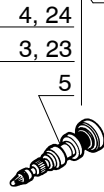

FIRESTONE TREAD



GOODYEAR TREAD

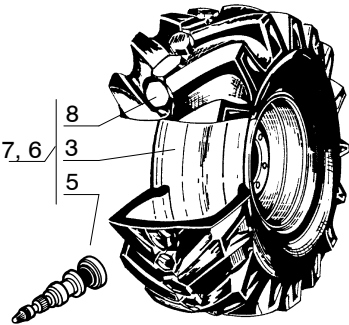

GOODYEAR TREAD

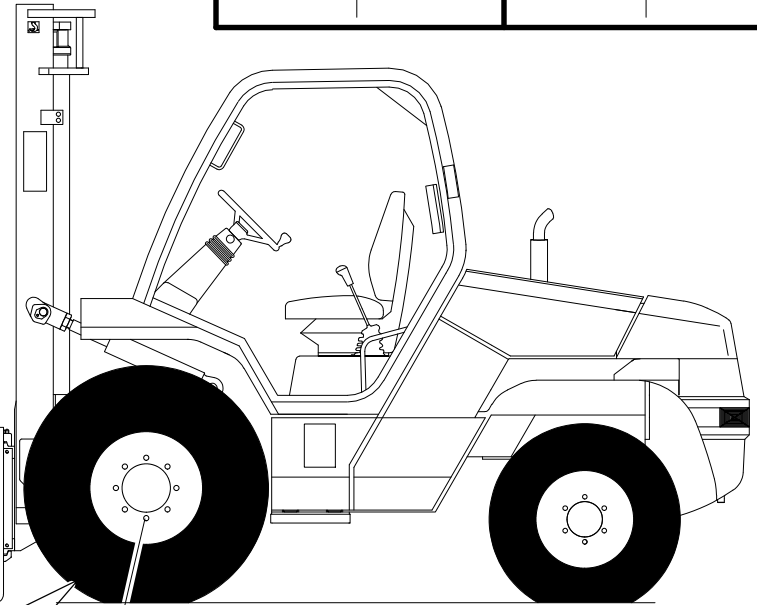

DURAMAX TREAD

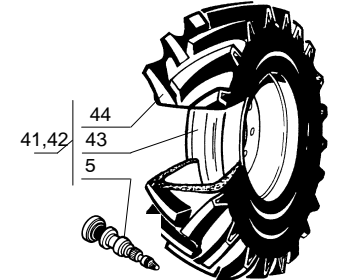

OTR TREAD

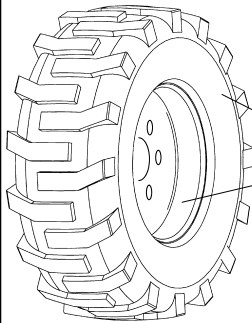

9, 10

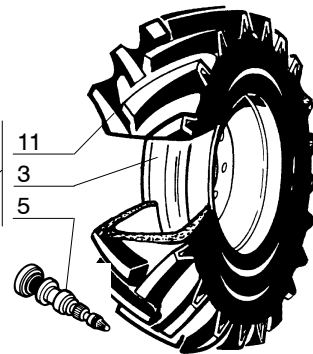

MICHELIN TREAD

16, 17

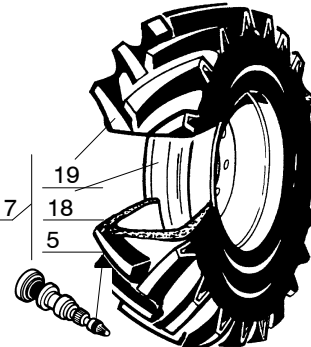

MICHELIN TREAD

PRIMEX TREAD

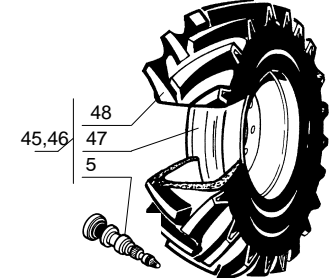

804437)D

1	TIRES AND WHEELS, FRONT		QUANTITY / MODEL									3 AA 245					
			M30-4T	M40-4T	M50-4T		M30-4T H	M40-4T H	M50-4T H		M30-4T L	M40-4T L	M50-4T L		M30-4T HL	M40-4T HL	M50-4T HL
ITEM	PART NO.	DESCRIPTION	M30-2T	M40-2T	M50-2T		M30-2T H	M40-2T H	M50-2T H		M30-2T L	M40-2T L	M50-2T L		M30-2T HL	M40-2T HL	M50-2T HL
1	804460R	Front wheel assembly, RH (100 & 81 in. cabs, 6K) Titan 17.5x24 R-4	1				1				1				1		
2	804460L	Front wheel assembly, LH (100 & 81 in. cabs, 6K) Titan 17.5x24 R-4	1				1				1				1		
3	804458	Front rim (100 & 81 in. cabs, 6K)	A/R				A/R				A/R				A/R		
4	802127	Front tire, Titan 17.5x24 R-4 (100 & 81 in. cabs, 6K)	A/R				A/R				A/R				A/R		
5	802118	Tire valve, front	A/R				A/R				A/R				A/R		
6	804462R	Front wheel assembly, RH (100 & 81 in. cabs, 6K) Good Year 16.9x24 R-4	1				1				1				1		
7	804462L	Front wheel assembly, LH (100 & 81 in. cabs, 6K) Good Year 16.9x24 R-4	1				1				1				1		
8	803007	Front tire, Good Year 16.9x24 R-4 (100 & 81 in. cabs, 6K)	A/R				A/R				A/R				A/R		
9	804464R	Front wheel assembly, RH (100 & 81 in. cabs, 6K) Michelin 17.5x24 XM27	1				1				1				1		
10	804464L	Front wheel assembly, LH (100 & 81 in. cabs, 6K) Michelin 17.5x24 XM27	1				1				1				1		
11	803011	Front tire, Michelin 17.5x24 XM27 (100 & 81 in. cabs, 6K)	A/R				A/R				A/R				A/R		
12	804442R	Front wheel assembly, RH (77 in. cab, 6K) OTR 15x19.5	1				1				1				1		
13	804442L	Front wheel assembly, LH (77 in. cab, 6K) OTR 15x19.5	1				1				1				1		

2	TIRES AND WHEELS, FRONT		QUANTITY / MODEL									3 AA 245					
			M30-4T	M40-4T	M50-4T		M30-4T H	M40-4T H	M50-4T H		M30-4T L	M40-4T L	M50-4T L		M30-4T HL	M40-4T HL	M50-4T HL
ITEM	PART NO.	DESCRIPTION	M30-2T	M40-2T	M50-2T		M30-2T H	M40-2T H	M50-2T H		M30-2T L	M40-2T L	M50-2T L		M30-2T HL	M40-2T HL	M50-2T HL
14	804440	Front rim (77 in. cab, 6K)	A/R				A/R				A/R				A/R		
15	802126	Front tire, OTR 15x19.5 (77 in. cab, 6K)	A/R				A/R				A/R				A/R		
16	804439R	Front wheel assembly, RH (77 in. cab, 6K) Michelin 375/75R20 XM27	1				1				1				1		
17	804439L	Front wheel assembly, LH (77 in. cab, 6K) Michelin 375/75R20 XM27	1				1				1				1		
18	804436	Front rim (77 in. cab, 6K)	A/R				A/R				A/R				A/R		
19	802964	Front tire, Michelin 375/75R20 XM27 (77 in. cab, 6K)	A/R				A/R				A/R				A/R		
20	109480	Nut, drive wheel	A/R				A/R				A/R				A/R		
21	804445R	Front wheel assembly, RH (100 & 81 in. cab)		1	1			1	1			1	1			1	1
22	804445L	Front wheel assembly, LH (100 & 81 in. cab)		1	1			1	1			1	1			1	1
23	804443	Front rim (100 & 81 in. cab)		A/R	A/R			A/R	A/R			A/R	A/R			A/R	A/R
24	802128	Front tire, Titan 15.5x25 L-2 (100 & 81 in. cab)		A/R	A/R			A/R	A/R			A/R	A/R			A/R	A/R
25	812039	Front tire, Firestone 15.5x25 L-2		A/R	A/R			A/R	A/R			A/R	A/R			A/R	A/R
26	812038R	Front wheel assembly, RH		1	1			1	1			1	1			1	1
27	812038L	Front wheel assembly, LH		1	1			1	1			1	1			1	1
30	806937R	Front wheel assembly, RH	1				1				1				1		
31	806937L	Front wheel assembly, LH	1				1				1				1		
32	806938	Front tire, 14.9 x 24	A/R				A/R				A/R				A/R		
33	806939	Rim	A/R				A/R				A/R				A/R		

3	TIRE AND WHEELS FRONT		QUANTITY / MODEL						3 AA 245					
			M 30-4 T	M 40-4 T	M 50-4 T	M 30-4 TH	M 40-4 TH	M 50-4 TH	M 30-4 TL	M 40-4 TL	M 50-4 TL	M 30-4 THL	M 40-4 THL	M 50-4 THL
ITEM	PART NO.	DESCRIPTION	M 30-2 T	M 40-2 T	M 50-2 T	M 30-2 TH	M 40-2 TH	M 50-2 TH	M 30-2 TL	M 40-2 TL	M 50-2 TL	M 30-2 THL	M 40-2 THL	M 50-2 THL
34*	812613L	Tire Assy. LH	1			1			1			1		
35*	812615	Rim Assy.	1			1			1			1		
36*	812614	Tire 445/55D19.5	1			1			1			1		
37*	812613R	Tire Assy. RH	1			1			1			1		
38*	812615	Rim Assy.	1			1			1			1		
39*	812614	Tire 445/55D19.5	1			1			1			1		
40*	807833	Angle												
* THIS ITEMS ARE NOT SHOWN.														
41	813125L	Tire Assy. Drive LH Duramax 15.5x25		1	1		1	1		1	1		1	1
42	813125R	Tire Assy. Drive RH Duramax 15.5x25		1	1		1	1		1	1		1	1
43	804443	Rim Assy.		A/R	A/R		A/R	A/R		A/R	A/R		A/R	A/R
44	813126	Tire, DURAMAX 15.5x25		A/R	A/R		A/R	A/R		A/R	A/R		A/R	A/R
45	813075L	Tire Assy, LH		1	1		1	1		1	1		1	1
46	813075R	Tire Assy. RH		1	1		1	1		1	1		1	1
47	804443	Rim Assy.		A/R	A/R		A/R	A/R		A/R	A/R		A/R	A/R
48	813076	Tire, PRIMEX 15.5x25		A/R	A/R		A/R	A/R		A/R	A/R		A/R	A/R

2.00

3 AA 246
TIER III

TIRES AND WHEELS, REAR

M30-2T	M30-4T	M30-2T H	M30-4T H
M40-2T	M40-4T	M40-2T H	M40-4T H
M50-2T	M50-4T	M50-2T H	M50-4T H
M30-2T L	M30-4T L	M30-2T H L	M30-4T H L
M40-2T L	M40-4T L	M40-2T H L	M40-4T H L
M50-2T L	M50-4T L	M50-2T H L	M50-4T H L

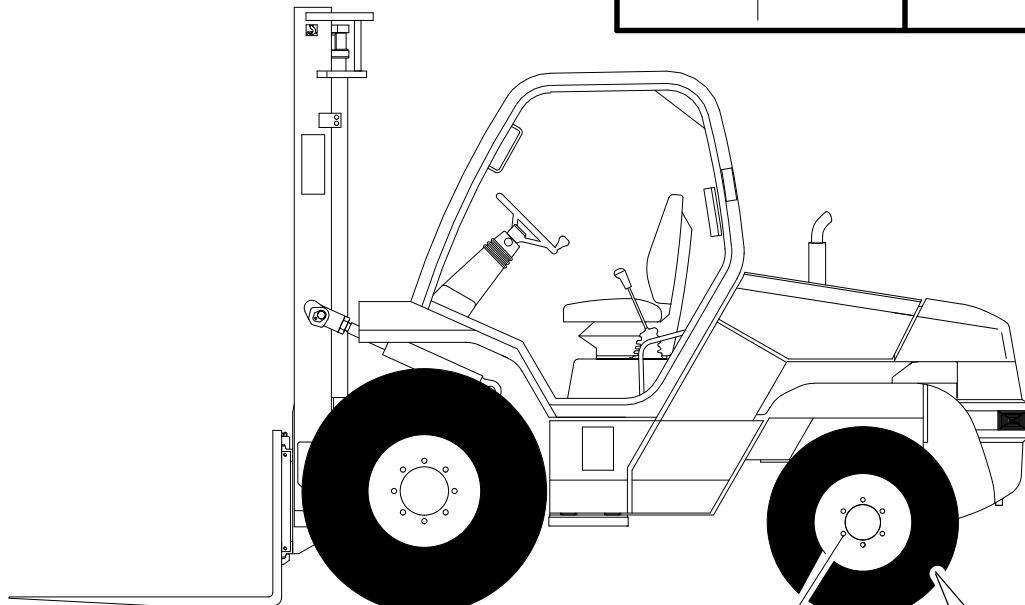

OTR TREAD (2WD)

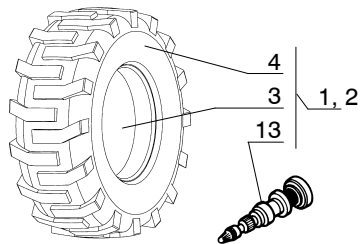

OTR TREAD (2WD)

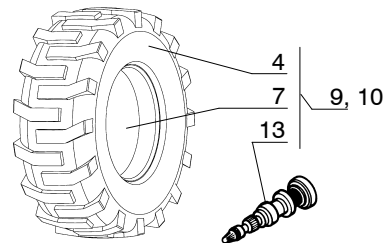

OTR TREAD (4WD)

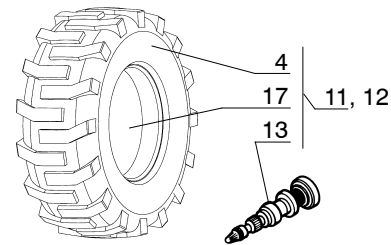

MICHELIN TREAD (2WD)

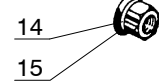
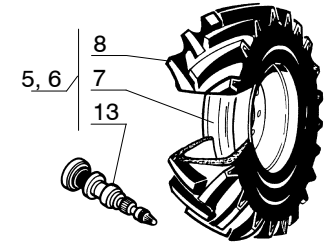

			QUANTITY / MODEL									3 AA 246		
1	TIRES AND WHEELS, REAR													
ITEM	PART NO.	DESCRIPTION	M30-2T	M40-2T	M50-2T	M30-2T H	M40-2T H	M50-2T H	M30-2T L	M40-2T L	M50-2T L	M30-2T HL	M40-2T HL	M50-2T HL
1	804454R	Rear wheel assembly, RH (100 & 81 in. cabs, 6K - 12K) OTR 12x16.5	1	1	1	1	1	1	1	1	1	1	1	1
2	804454L	Rear wheel assembly, LH (100 & 81 in. cabs, 6K - 12K) OTR 12x16.5	1	1	1	1	1	1	1	1	1	1	1	1
3	804452	Rear rim (100 & 81 in. cabs, 6K - 12K)	A/R	A/R	A/R	A/R	A/R	A/R	A/R	A/R	A/R	A/R	A/R	A/R
4	802661	Rear tire, OTR 12x16.5 (100 & 81 in. cabs, 6K - 12K)1	A/R	A/R	A/R	A/R	A/R	A/R	A/R	A/R	A/R	A/R	A/R	A/R
5	804448R	Rear wheel assembly, RH (100, 81 & 77 in. cabs, 6K) Michelin 12x16.5 XZSL	1			1			1			1		
6	804448L	Rear wheel assembly, LH (100, 81 & 77 in. cabs, 6K) Michelin 12x16.5 XZSL	1			1			1			1		
7	804446	Rear rim (100, 81 & 77 in. cabs, 6K)	A/R	A/R	A/R	A/R	A/R	A/R	A/R	A/R	A/R	A/R	A/R	A/R
8	803004	Rear tire, Michelin 12x16.5 XZSL (100, 81 & 77 in. cabs, 6K)	A/R	A/R	A/R	A/R	A/R	A/R	A/R	A/R	A/R	A/R	A/R	A/R
9	804450R	Rear wheel assembly, RH (77 in. cab, 6K) OTR 12x16.5	1			1			1			1		
10	804450L	Rear wheel assembly, RH (77 in. cab, 6K) OTR 12x16.5	1			1			1			1		
11	804457R	Rear wheel assembly, RH (100 & 81 in. cabs, 6K - 12K) OTR 12x16.5	1	1	1	1	1	1	1	1	1	1	1	1
12	804457L	Rear wheel assembly, LH (100 & 81 in. cabs, 6K - 12K) OTR 12x16.5	1	1	1	1	1	1	1	1	1	1	1	1
13	803543	Valve stem, rear	A/R	A/R	A/R	A/R	A/R	A/R	A/R	A/R	A/R	A/R	A/R	A/R
14	421116	Nut, rear steer wheel (2WD ONLY)	A/R	A/R	A/R	A/R	A/R	A/R	A/R	A/R	A/R	A/R	A/R	A/R
15	475260	Nut, rear steer wheel (4WD ONLY)	A/R	A/R	A/R	A/R	A/R	A/R	A/R	A/R	A/R	A/R	A/R	A/R

4 AA 601

TIER III

AIR INTAKE SYSTEM, INSTALLATION

M30-2T	M30-4T	M30-2T H	M30-4T H
M40-2T	M40-4T	M40-2T H	M40-4T H
M50-2T	M50-4T	M50-2T H	M50-4T H

M30-2T L	M30-4T L	M30-2T H L	M30-4T H L
M40-2T L	M40-4T L	M40-2T H L	M40-4T H L
M50-2T L	M50-4T L	M50-2T H L	M50-4T H L

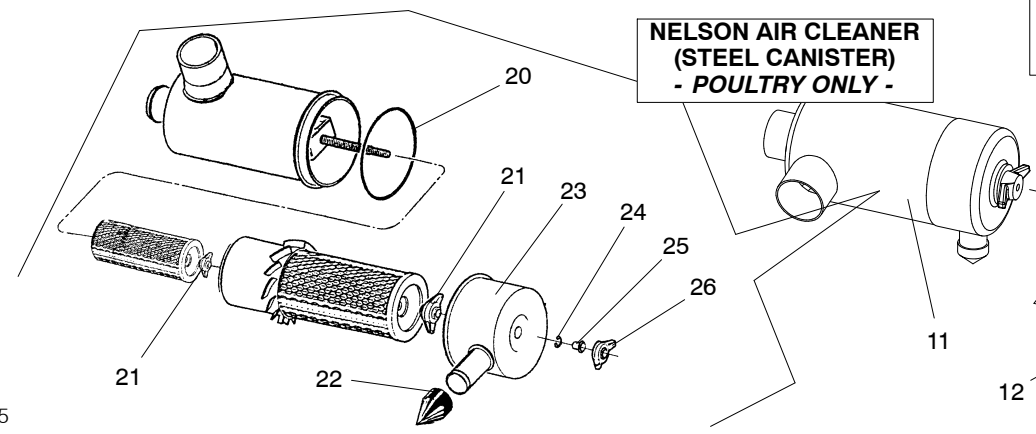
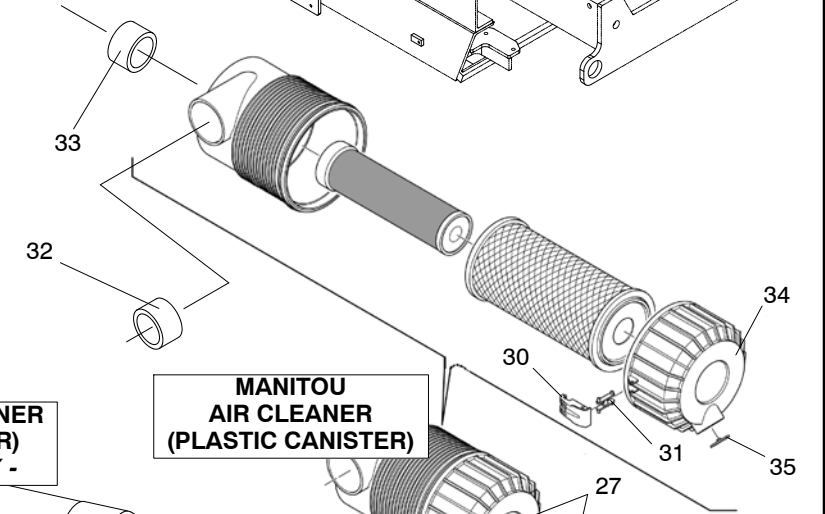
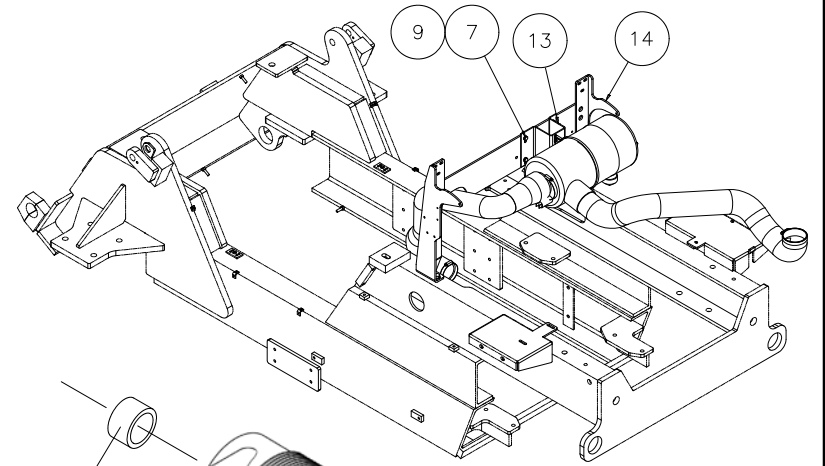
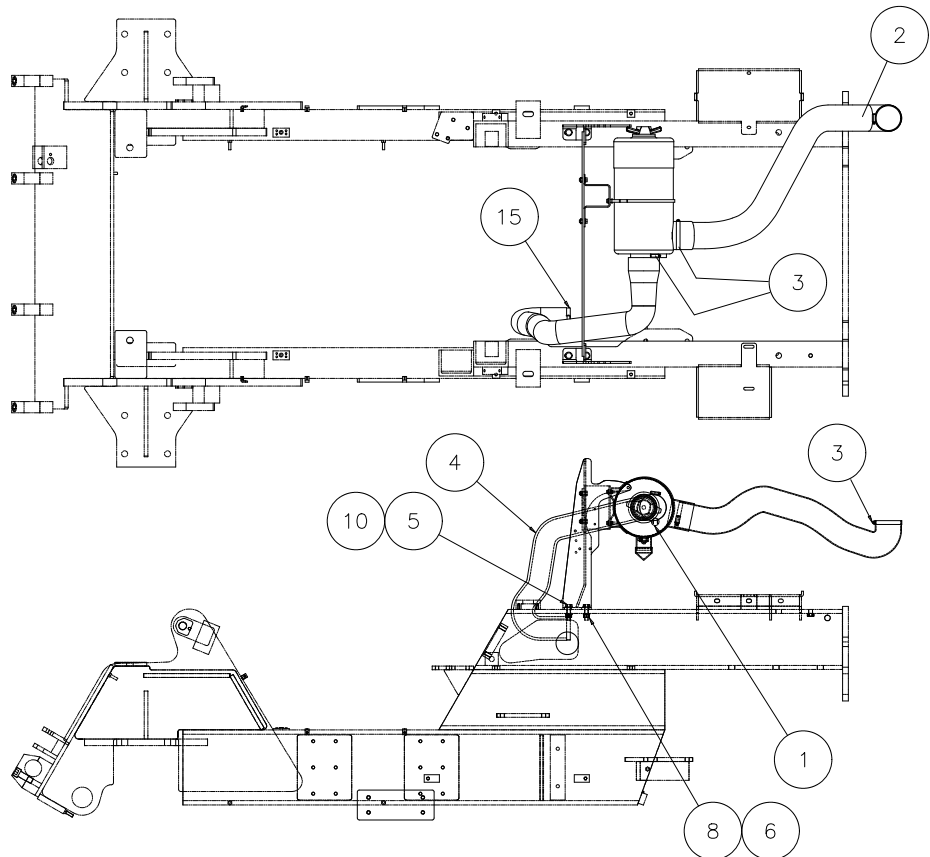

**NELSON AIR CLEANER
(STEEL CANISTER)
- POULTRY ONLY -**

**MANITOU
AIR CLEANER
(PLASTIC CANISTER)**

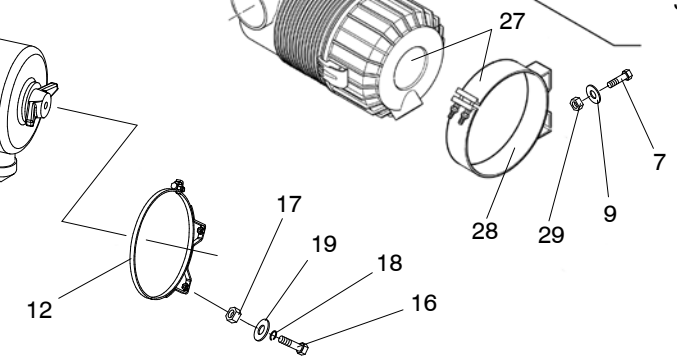

1	AIR INTAKE SYSTEM, INSTALLATION		QUANTITY / MODEL												4 AA 601		
			M30-4T	M40-4T	M50-4T		M30-4T H	M40-4T H	M50-4T H		M30-4T L	M40-4T L	M50-4T L		M30-4T HL	M40-4T HL	M50-4T HL
ITEM	PART NO.	DESCRIPTION	M30-2T	M40-2T	M50-2T		M30-2T H	M40-2T H	M50-2T H		M30-2T L	M40-2T L	M50-2T L		M30-2T HL	M40-2T HL	M50-2T HL
1	224776	Air filter clog switch	1	1	1	1	1	1	1	1	1	1	1	1	1	1	1
2	226807	Hose, intake	1	1	1	1	1	1	1	1	1	1	1	1	1	1	1
3	229587	Hose clamp	3	3	3	3	3	3	3	3	3	3	3	3	3	3	3
4	247594	Hose, turbo	1	1	1	1	1	1	1	1	1	1	1	1	1	1	1
5	29475	Bolt	4	4	4	4	4	4	4	4	4	4	4	4	4	4	4
6	42231	Washer	4	4	4	4	4	4	4	4	4	4	4	4	4	4	4
7	42347	Bolt	6	6	6	6	6	6	6	6	6	6	6	6	6	6	6
8	58548	Nut	4	4	4	4	4	4	4	4	4	4	4	4	4	4	4
9	61674	Washer	6	6	6	6	6	6	6	6	6	6	6	6	6	6	6
10	61676	Washer	4	4	4	4	4	4	4	4	4	4	4	4	4	4	4
11	804338	Filter assembly, complete, Nelson (steel canister)	1	1	1	1	1	1	1	1	1	1	1	1	1	1	1
12	804339	Band, mounting	2	2	2	2	2	2	2	2	2	2	2	2	2	2	2
13	804500	Bracket, air filter	1	1	1	1	1	1	1	1	1	1	1	1	1	1	1
14	807459	Bracket, engine bonnet	1	1	1	1	1	1	1	1	1	1	1	1	1	1	1
15	B2236-12	Clamp	1	1	1	1	1	1	1	1	1	1	1	1	1	1	1
16	K20424	Bolt	2	2	2	2	2	2	2	2	2	2	2	2	2	2	2
17	K33795	Nut	2	2	2	2	2	2	2	2	2	2	2	2	2	2	2
18	K34805	Washer, lock	2	2	2	2	2	2	2	2	2	2	2	2	2	2	2
19	K44719	Washer, flat	2	2	2	2	2	2	2	2	2	2	2	2	2	2	2
20	426206	O-ring	1	1	1	1	1	1	1	1	1	1	1	1	1	1	1
21	803653	Wing nut	2	2	2	2	2	2	2	2	2	2	2	2	2	2	2
22	426203	Dust ejector	1	1	1	1	1	1	1	1	1	1	1	1	1	1	1
23	803656	Cover, filter housing	1	1	1	1	1	1	1	1	1	1	1	1	1	1	1
24	426197	E-ring	1	1	1	1	1	1	1	1	1	1	1	1	1	1	1
25	426196	Washer	1	1	1	1	1	1	1	1	1	1	1	1	1	1	1
26	426198	Wing nut	1	1	1	1	1	1	1	1	1	1	1	1	1	1	1
27	224711	Filter assembly, complete, Manitou (plastic canister)	1	1	1	1	1	1	1	1	1	1	1	1	1	1	1
28	224712	Clamp	1	1	1	1	1	1	1	1	1	1	1	1	1	1	1
29	58528	Nut	2	2	2	2	2	2	2	2	2	2	2	2	2	2	2

4 AA 602
TIER III

EXHAUST SYSTEM ASSEMBLY

M30-2T	M30-4T	M30-2T H	M30-4T H
M40-2T	M40-4T	M40-2T H	M40-4T H
M50-2T	M50-4T	M50-2T H	M50-4T H
M30-2T L	M30-4T L	M30-2T H L	M30-4T H L
M40-2T L	M40-4T L	M40-2T H L	M40-4T H L
M50-2T L	M50-4T L	M50-2T H L	M50-4T H L

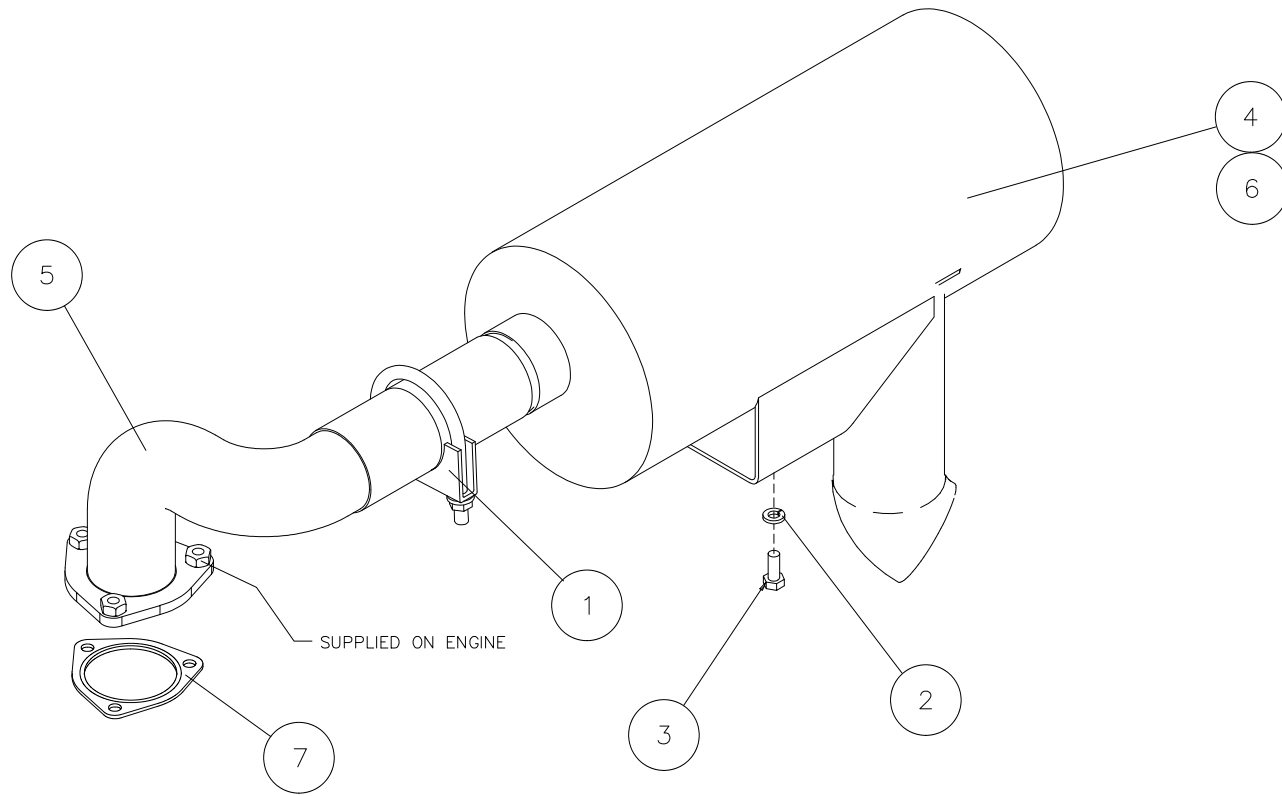

1	EXHAUST SYSTEM ASSEMBLY		QUANTITY / MODEL											4 AA 602			
			M30-4T	M40-4T	M50-4T		M30-4T H	M40-4T H	M50-4T H		M30-4T L	M40-4T L	M50-4T L		M30-4T HL	M40-4T HL	M50-4T HL
ITEM	PART NO.	DESCRIPTION	M30-2T	M40-2T	M50-2T		M30-2T H	M40-2T H	M50-2T H		M30-2T L	M40-2T L	M50-2T L		M30-2T HL	M40-2T HL	M50-2T HL
1	423625	Clamp	1	1	1	1	1	1	1	1	1	1	1	1	1	1	1
2	42325	Washer	2	2	2	2	2	2	2	2	2	2	2	2	2	2	2
3	42347	Bolt	2	2	2	2	2	2	2	2	2	2	2	2	2	2	2
4	803501	Muffler, exhaust down (standard)	1	1	1	1	1	1	1	1	1	1	1	1	1	1	1
5	804684	Exhaust tube	1	1	1	1	1	1	1	1	1	1	1	1	1	1	1
6	803607	Muffler, Catalytic (optional)	1	1	1	1	1	1	1	1	1	1	1	1	1	1	1
7	551768	Gasket, metal	1	1	1	1	1	1	1	1	1	1	1	1	1	1	1

4 AA 603
TIER III

RADIATOR INSTALLATION

M30-2T	M30-4T	M30-2T H	M30-4T H
M40-2T	M40-4T	M40-2T H	M40-4T H
M50-2T	M50-4T	M50-2T H	M50-4T H
M30-2T L	M30-4T L	M30-2T H L	M30-4T H L
M40-2T L	M40-4T L	M40-2T H L	M40-4T H L
M50-2T L	M50-4T L	M50-2T H L	M50-4T H L

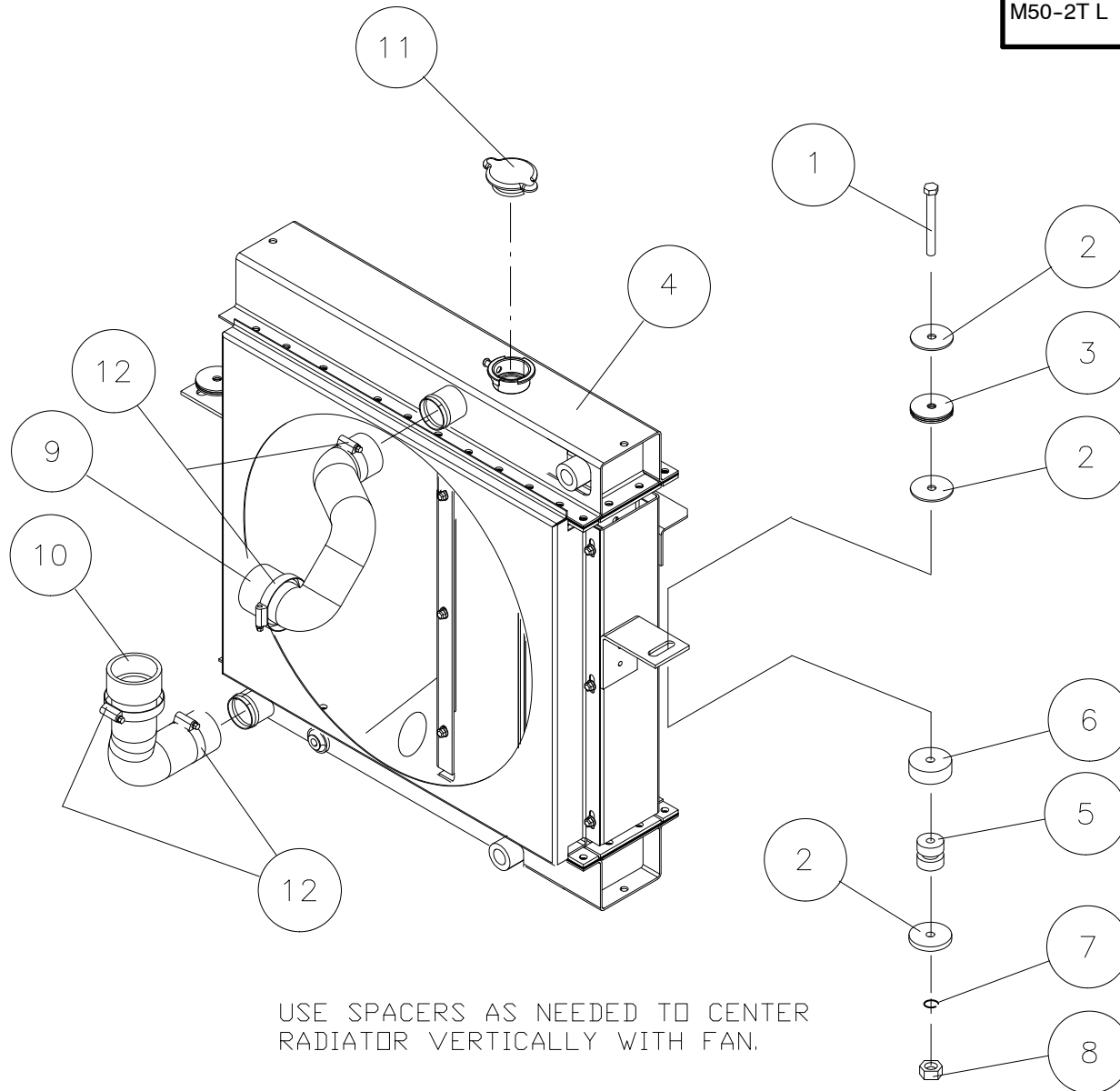

USE SPACERS AS NEEDED TO CENTER
RADIATOR VERTICALLY WITH FAN.

1	RADIATOR INSTALLATION		QUANTITY / MODEL												4 AA 603		
			M30-4T	M40-4T	M50-4T		M30-4T H	M40-4T H	M50-4T H		M30-4T L	M40-4T L	M50-4T L		M30-4T HL	M40-4T HL	M50-4T HL
ITEM	PART NO.	DESCRIPTION	M30-2T	M40-2T	M50-2T		M30-2T H	M40-2T H	M50-2T H		M30-2T L	M40-2T L	M50-2T L		M30-2T HL	M40-2T HL	M50-2T HL
1	58538	Bolt	2	2	2	2	2	2	2	2	2	2	2	2	2	2	2
2	36010	Washer	A/R	A/R	A/R	A/R	A/R	A/R	A/R	A/R	A/R	A/R	A/R	A/R	A/R	A/R	A/R
3	73979	Rubber washer	A/R	A/R	A/R	A/R	A/R	A/R	A/R	A/R	A/R	A/R	A/R	A/R	A/R	A/R	A/R
4	807296	Radiator	1	1	1	1	1	1	1	1	1	1	1	1	1	1	1
5	806757	Isolator	2	2	2	2	2	2	2	2	2	2	2	2	2	2	2
6	806789	Spacer, 1/4 in.	A/R	A/R	A/R	A/R	A/R	A/R	A/R	A/R	A/R	A/R	A/R	A/R	A/R	A/R	A/R
7	42232	Washer	2	2	2	2	2	2	2	2	2	2	2	2	2	2	2
8	56354	Nut	2	2	2	2	2	2	2	2	2	2	2	2	2	2	2
9	248379	Hose, upper	1	1	1	1	1	1	1	1	1	1	1	1	1	1	1
10	248378	Hose, lower	1	1	1	1	1	1	1	1	1	1	1	1	1	1	1
11	804722	Radiator cap	1	1	1	1	1	1	1	1	1	1	1	1	1	1	1
12	B2236-8	Hose clamp	4	4	4	4	4	4	4	4	4	4	4	4	4	4	4

4 AA 604

TIER III

RADIATOR COOLING TRAY

M30-2T	M30-4T	M30-2T H	M30-4T H
M40-2T	M40-4T	M40-2T H	M40-4T H
M50-2T	M50-4T	M50-2T H	M50-4T H
M30-2T L	M30-4T L	M30-2T H L	M30-4T H L
M40-2T L	M40-4T L	M40-2T H L	M40-4T H L
M50-2T L	M50-4T L	M50-2T H L	M50-4T H L

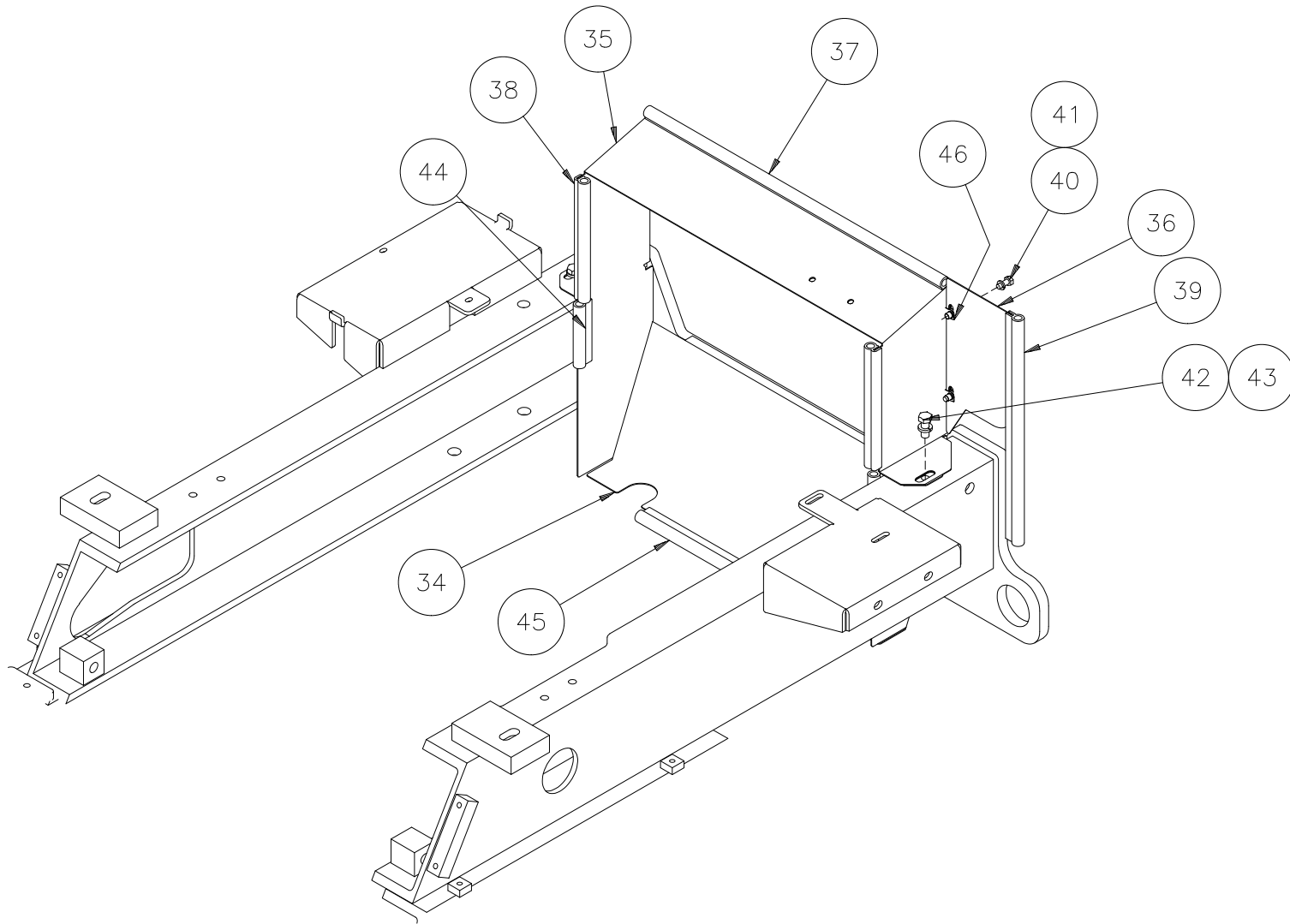

1	RADIATOR COOLING TRAY											QUANTITY / MODEL			4 AA 604			
	ITEM	PART NO.	DESCRIPTION	M30-4T	M40-4T	M50-4T		M30-4T H	M40-4T H	M50-4T H		M30-4T L	M40-4T L	M50-4T L		M30-4T HL	M40-4T HL	M50-4T HL
				M30-2T	M40-2T	M50-2T		M30-2T H	M40-2T H	M50-2T H		M30-2T L	M40-2T L	M50-2T L		M30-2T HL	M40-2T HL	M50-2T HL
34	813077	Cooler tray, bottom	1	1	1	1	1	1	1	1	1	1	1	1	1	1	1	1
35	807464	Cooler tray, top	1	1	1	1	1	1	1	1	1	1	1	1	1	1	1	1
36	802885	Plate	1	1	1	1	1	1	1	1	1	1	1	1	1	1	1	1
37	802889	Weather strip	1	1	1	1	1	1	1	1	1	1	1	1	1	1	1	1
38	802892	Weather strip	2	2	2	2	2	2	2	2	2	2	2	2	2	2	2	2
39	802887	Weather strip	1	1	1	1	1	1	1	1	1	1	1	1	1	1	1	1
40	42347	Bolt	2	2	2	2	2	2	2	2	2	2	2	2	2	2	2	2
41	42325	Washer, lock	2	2	2	2	2	2	2	2	2	2	2	2	2	2	2	2
42	63547	Bolt	2	2	2	2	2	2	2	2	2	2	2	2	2	2	2	2
43	42231	Washer, lock	2	2	2	2	2	2	2	2	2	2	2	2	2	2	2	2
44	Z4054	Weather strip x 4.5 in.	2	2	2	2	2	2	2	2	2	2	2	2	2	2	2	2
45	Z4054	Weather strip x 30 in.	1	1	1	1	1	1	1	1	1	1	1	1	1	1	1	1
46	805537	U-nut, replaces Items 7 and 8	2	2	2	2	2	2	2	2	2	2	2	2	2	2	2	2

4 AA 605
TIER III

ENGINE MOUNTING

M30-2T	M30-4T	M30-2T H	M30-4T H
M40-2T	M40-4T	M40-2T H	M40-4T H
M50-2T	M50-4T	M50-2T H	M50-4T H
M30-2T L	M30-4T L	M30-2T H L	M30-4T H L
M40-2T L	M40-4T L	M40-2T H L	M40-4T H L
M50-2T L	M50-4T L	M50-2T H L	M50-4T H L

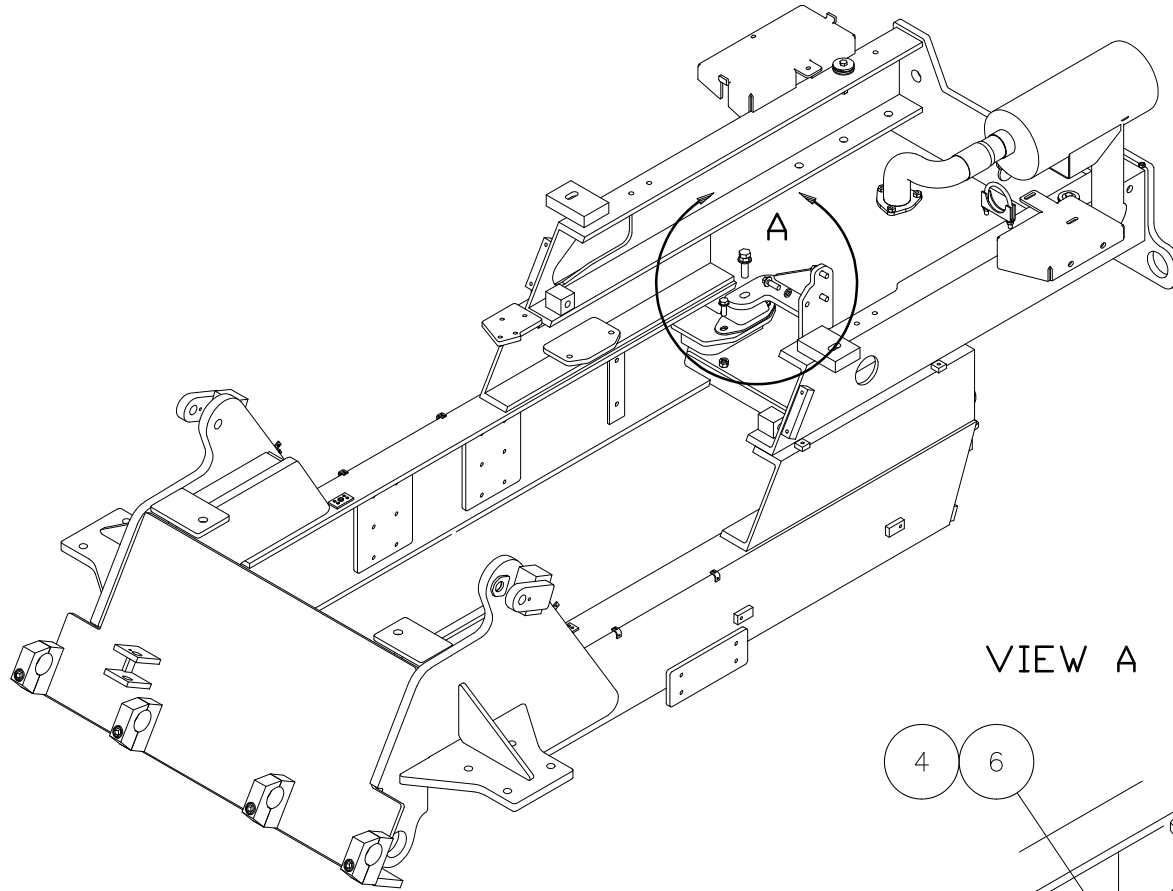

VIEW A

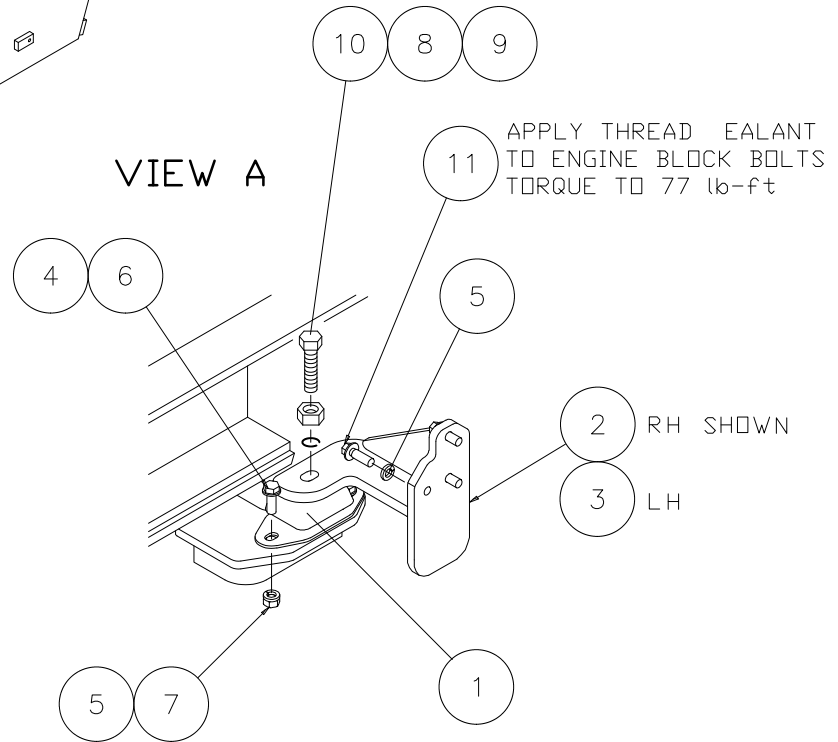

1	ENGINE MOUNTING		QUANTITY / MODEL												4 AA 605			
			M30-4T	M40-4T	M50-4T		M30-4T H	M40-4T H	M50-4T H		M30-4T L	M40-4T L	M50-4T L		M30-4T HL	M40-4T HL	M50-4T HL	
ITEM	PART NO.	DESCRIPTION	M30-2T	M40-2T	M50-2T		M30-2T H	M40-2T H	M50-2T H		M30-2T L	M40-2T L	M50-2T L		M30-2T HL	M40-2T HL	M50-2T HL	
1	242496	Shock mount	2	2	2	2	2	2	2	2	2	2	2	2	2	2	2	2
2	801949	Engine mount, rear RH	1	1	1	1	1	1	1	1	1	1	1	1	1	1	1	1
3	801950	Engine mount, rear LH	1	1	1	1	1	1	1	1	1	1	1	1	1	1	1	1
4	61676	Washer	4	4	4	4	4	4	4	4	4	4	4	4	4	4	4	4
5	42231	Washer	10	10	10	10	10	10	10	10	10	10	10	10	10	10	10	10
6	58546	Bolt	4	4	4	4	4	4	4	4	4	4	4	4	4	4	4	4
7	58548	Nut	4	4	4	4	4	4	4	4	4	4	4	4	4	4	4	4
8	62203	Washer	2	2	2	2	2	2	2	2	2	2	2	2	2	2	2	2
9	42813	Nut	2	2	2	2	2	2	2	2	2	2	2	2	2	2	2	2
10	168365	Bolt	2	2	2	2	2	2	2	2	2	2	2	2	2	2	2	2
11	KN605815	Bolt	6	6	6	6	6	6	6	6	6	6	6	6	6	6	6	6

4 AA 606
TIER III

TRANSMISSION INSTALLATION, 4-SPEED (2WD & 4WD)

M30-2T	M30-4T		
M40-2T	M40-4T		
M50-2T	M50-4T		
M30-2T L	M30-4T L		
M40-2T L	M40-4T L		
M50-2T L	M50-4T L		

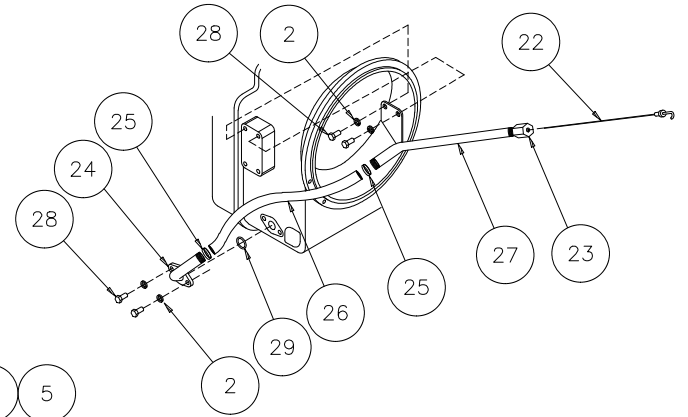
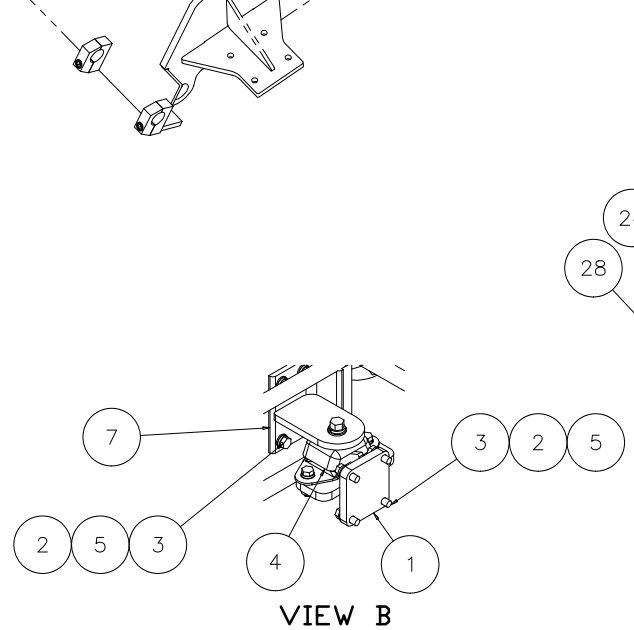
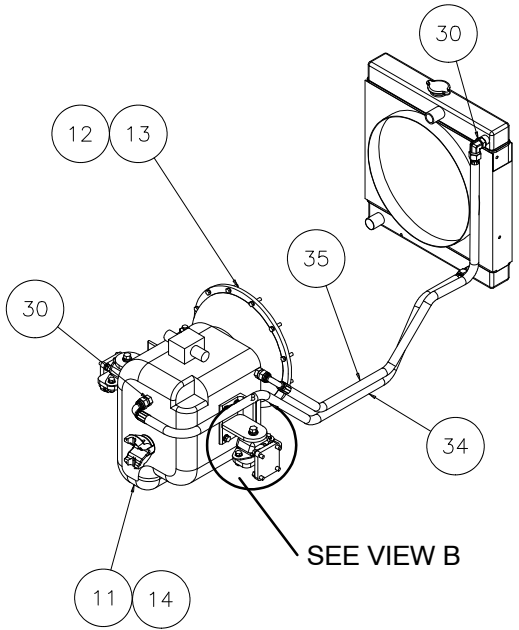
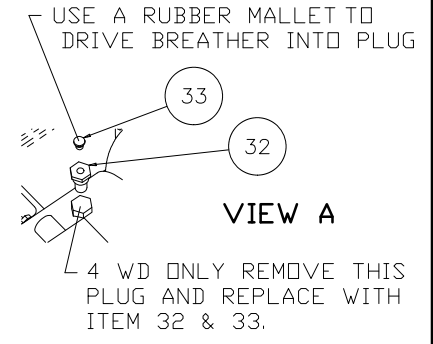
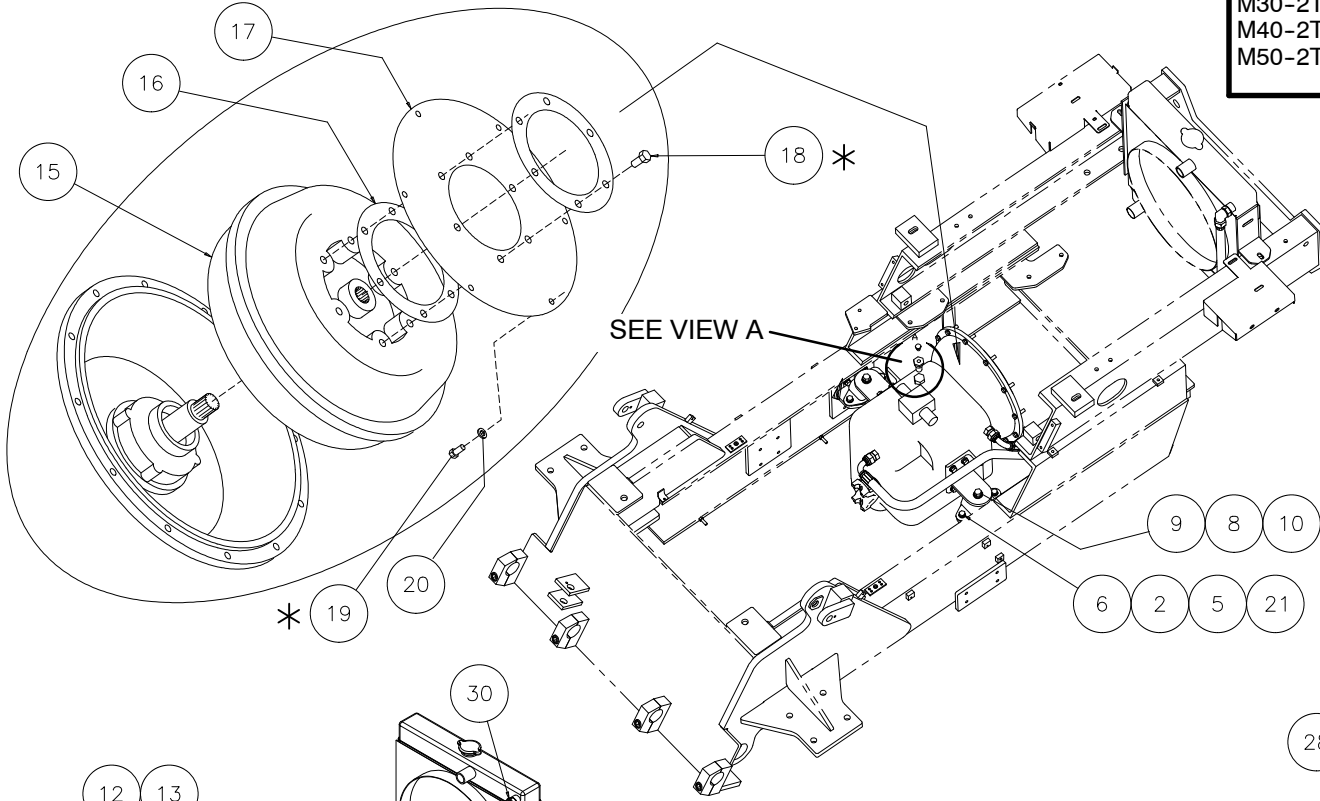

* - APPLY LOCTITE 242

1	TRANSMISSION INSTALLATION, 4-SPEED (2WD & 4WD)		QUANTITY / MODEL												4 AA 606				
			M30-4T	M40-4T	M50-4T						M30-4T L	M40-4T L	M50-4T L						
			M30-2T	M40-2T	M50-2T						M30-2T L	M40-2T L	M50-2T L						
ITEM	PART NO.	DESCRIPTION	M30-2T	M40-2T	M50-2T							M30-2T L	M40-2T L	M50-2T L					
1	801820	Transmission mount, lower	2	2	2	2						2	2	2	2				
2	42231	Washer	16	16	16	16						16	16	16	16				
3	58546	Bolt	16	16	16	16						16	16	16	16				
4	242496	Motor mount, rubber	2	2	2	2						2	2	2	2				
5	61676	Washer	12	12	12	12						12	12	12	12				
6	29475	Bolt	4	4	4	4						4	4	4	4				
7	801822	Transmission mount, upper	2	2	2	2						2	2	2	2				
8	62203	Washer	2	2	2	2						2	2	2	2				
9	42322	Washer	2	2	2	2						2	2	2	2				
10	58588	Bolt	2	2	2	2						2	2	2	2				
11	222573	Transmission, 4WD (ALL 4-SPEED, 4WD MODELS)																	
12	KN630174	Washer	12	12	12	12						12	12	12	12				
13	KN605803	Bolt	12	12	12	12						12	12	12	12				
14	222572	Transmission, 2WD (ALL 4-SPEED, 2WD MODELS)																	
15	209372	Torque converter	1	1	1	1						1	1	1	1				
16	209374	Re-inforcing plate	2	2	2	2						2	2	2	2				
17	209373	Flex drive plate	1	1	1	1						1	1	1	1				
18	209376	Bolt	6	6	6	6						6	6	6	6				
19	807746	Bolt	6	6	6	6						6	6	6	6				
20	209573	Washer	6	6	6	6						6	6	6	6				
21	58548	Nut	4	4	4	4						4	4	4	4				
22	252947	Dipstick, transmission, nylon handle with o-ring	1	1	1	1						1	1	1	1				
23	252997	Fitting, for Item 22 dipstick 252947	1	1	1	1						1	1	1	1				
24	219432	Tube, weldment	1	1	1	1						1	1	1	1				
25	71940	Hose clamp	2	2	2	2						2	2	2	2				
26	802934	Hose	1	1	1	1						1	1	1	1				
27	812106	Tube, bent	1	1	1	1						1	1	1	1				
28	44807	Bolt	4	4	4	4						4	4	4	4				

			QUANTITY / MODEL										4 AA 606				
2 TRANSMISSION INSTALLATION, 4-SPEED (2WD & 4WD)			M30-4T	M40-4T	M50-4T						M30-4T L	M40-4T L	M50-4T L				
ITEM	PART NO.	DESCRIPTION	M30-2T	M40-2T	M50-2T						M30-2T L	M40-2T L	M50-2T L				
29	4039	O-ring	1	1	1	1					1	1	1	1			
30	R18147-5	Adapter	4	4	4	4					4	4	4	4			
32	246347	Plug	1	1	1	1					1	1	1	1			
33	109705	Breather	1	1	1	1					1	1	1	1			
34	804604	Hose assembly	1	1	1	1					1	1	1	1			
35	804605	Hose assembly	1	1	1	1					1	1	1	1			

4 AA 627
TIER III

GEAR LEVER ASSEMBLY, 4-SPEED TRANSMISSION, 2WD & 4WD

M30-2T	M30-4T		
M40-2T	M40-4T		
M50-2T	M50-4T		
M30-2T L	M30-4T L		
M40-2T L	M40-4T L		
M50-2T L	M50-4T L		

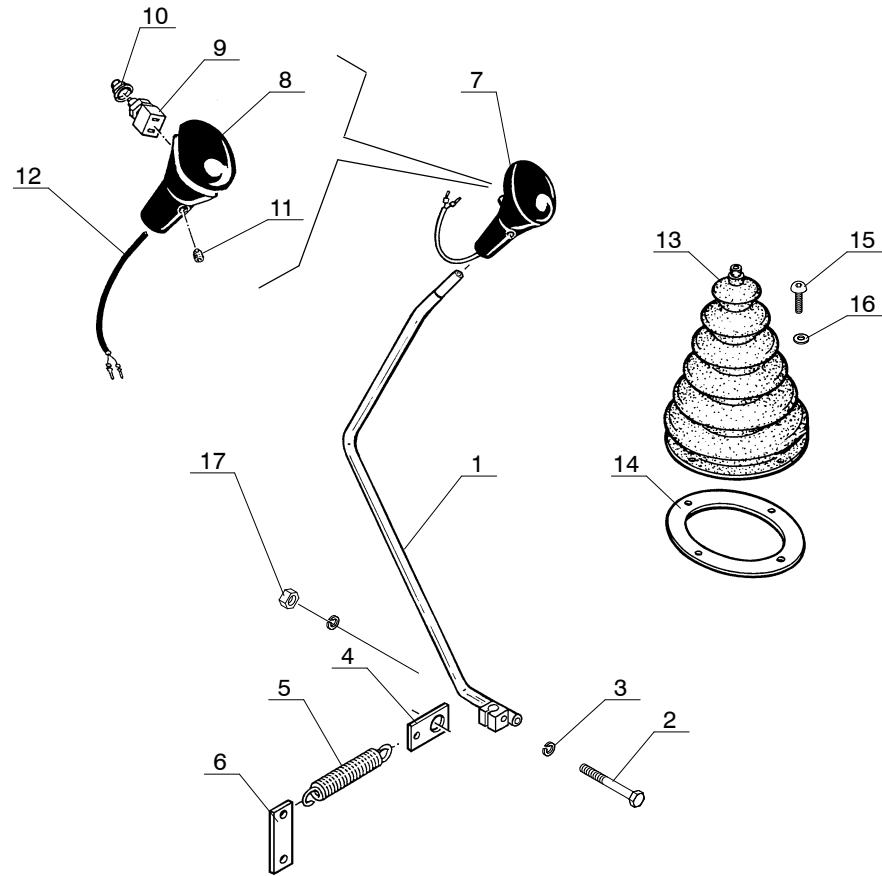

			QUANTITY / MODEL										4 AA 627					
1 GEAR LEVER ASSEMBLY, 4-SPEED TRANSMISSION, 2WD & 4WD			M30-4T	M40-4T	M50-4T						M30-4T L	M40-4T L	M50-4T L					
ITEM	PART NO.	DESCRIPTION	M30-2T	M40-2T	M50-2T						M30-2T L	M40-2T L	M50-2T L					
	803392	Gear lever assembly, complete (77 in. & 81 in. cab)	1	1	1	1					1	1	1	1				
	812083	Gear lever assembly, complete (100 in. cab only)	1	1	1	1					1	1	1	1				
1	803388	Lever, (77 in. & 81 in. cab)	1	1	1	1					1	1	1	1				
1	812079	Lever, (100 in. cab only)	1	1	1	1					1	1	1	1				
2	58552	Screw	1	1	1	1					1	1	1	1				
3	61676	Washer	1	1	1	1					1	1	1	1				
4	78086	Fixing spring	1	1	1	1					1	1	1	1				
5	80308	Spring	1	1	1	1					1	1	1	1				
6	164965	Fastening plate	1	1	1	1					1	1	1	1				
7	211278	Ball assembly	1	1	1	1					1	1	1	1				
8	551255	Cap	1	1	1	1					1	1	1	1				
9	551256	Switch, trans cut-off	1	1	1	1					1	1	1	1				
10	551258	Cap	1	1	1	1					1	1	1	1				
11	551257	Screw	1	1	1	1					1	1	1	1				
12	551259	Wire harness	1	1	1	1					1	1	1	1				
13	78088	Bellows	1	1	1	1					1	1	1	1				
14	803875	Fastening plate	1	1	1	1					1	1	1	1				
15	189172	Screw	4	4	4	4					4	4	4	4				
16	189857	Washer	4	4	4	4					4	4	4	4				
17	44672	Nut, lock	1	1	1	1					1	1	1	1				

4 AB 149
TIER III

HYDROSTATIC (TRANSMISSION) SYSTEM ASSEMBLY 1

M30-2T H	M30-4T H
M40-2T H	M40-4T H
M50-2T H	M50-4T H

M30-2T H L	M30-4T H L
M40-2T H L	M40-4T H L
M50-2T H L	M50-4T H L

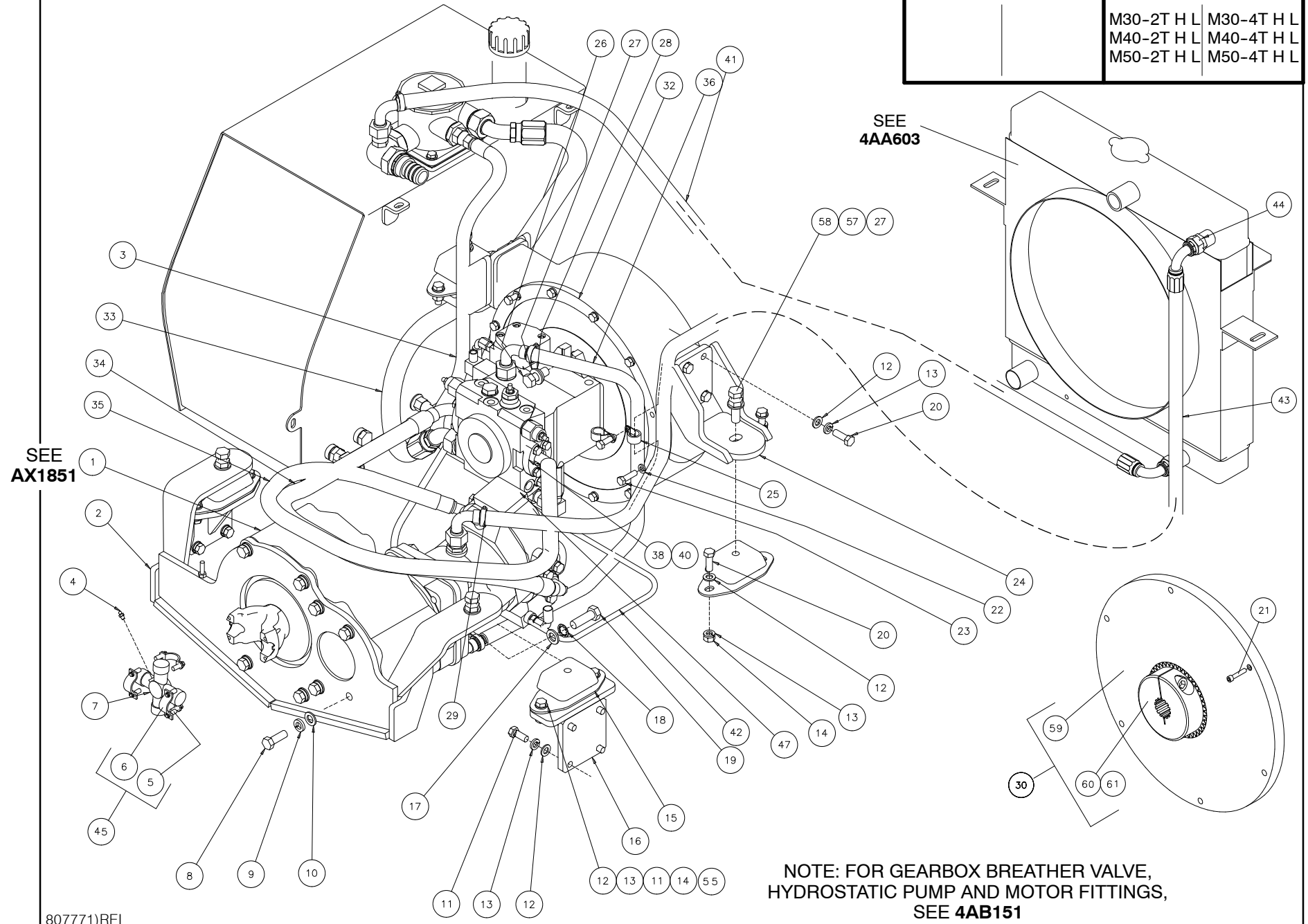

			QUANTITY / MODEL								4 AB 149																
													M30-4T H	M40-4T H	M50-4T H					M30-4T HL	M40-4T HL	M50-4T HL					
													M30-2T H	M40-2T H	M50-2T H					M30-2T HL	M40-2T HL	M50-2T HL					
ITEM	PART NO.	DESCRIPTION											M30-2T H	M40-2T H	M50-2T H					M30-2T HL	M40-2T HL	M50-2T HL					
1		HYDROSTATIC (TRANSMISSION) SYSTEM ASSEMBLY 1																									
1	801992	Gearbox assembly, 6 & 8 K											1	1							1	1					
1	226148	Gearbox assembly, 10 & 12 K													1	1							1	1			
2	802120	Gear box mount (NO FRAME LEVELING)											1	1	1	1											
2	803205	Gear box mount (FRAME LEVELING MODELS)																			1	1	1	1			
3	803885	Hose assembly, Pup 'T' to Tank											1	1	1	1					1	1	1	1			
4	162809	Grease fitting											1	1	1	1					1	1	1	1			
5	109752	Bolt											8	8	8	8					8	8	8	8			
6	109751	Clamp half											4	4	4	4					4	4	4	4			
7	424647	Crossblock, universal joint (Includes Item 4)											1	1	1	1					1	1	1	1			
8	58557	Bolt											8	8	8	8					8	8	8	8			
9	42256	Washer											8	8	8	8					8	8	8	8			
10	61680	Washer											8	8	8	8					8	8	8	8			
11	63547	Bolt											16	16	16	16					16	16	16	16			
12	61676	Washer											32	32	32	32					32	32	32	32			
13	42231	Washer											32	32	32	32					32	32	32	32			
14	58548	Nut											8	8	8	8					8	8	8	8			
15	242496	Shock mount											4	4	4	4					4	4	4	4			
16	802292	Mount, gear box											2	2	2	2					2	2	2	2			
17	KN630091	Washer											8	8	8	8					8	8	8	8			
18	KN630361	Washer											8	8	8	8					8	8	8	8			
19	61308	Bolt											4	4	4	4					4	4	4	4			
20	58546	Bolt											4	4	4	4					4	4	4	4			
21	K302211	Screw											6	6	6	6					6	6	6	6			
22	42232	Washer											12	12	12	12					12	12	12	12			
23	168351	Bolt											12	12	12	12					12	12	12	12			
24	801943	Mount, flywheel											2	2	2	2					2	2	2	2			
25	B3698-17	Clamp											2	2	2	2					2	2	2	2			

11.00

			QUANTITY / MODEL								4 AB 149						
							M30-4T H	M40-4T H	M50-4T H					M30-4T HL	M40-4T HL	M50-4T HL	
2 HYDROSTATIC (TRANSMISSION) SYSTEM ASSEMBLY 1							M30-2T H	M40-2T H	M50-2T H					M30-2T HL	M40-2T HL	M50-2T HL	
ITEM	PART NO.	DESCRIPTION					M30-2T H	M40-2T H	M50-2T H					M30-2T HL	M40-2T HL	M50-2T HL	
26	42818	Bolt					2	2	2	2				2	2	2	2
27	62203	Washer					6	6	6	6				6	6	6	6
28	42322	Washer					2	2	2	2				2	2	2	2
29	33593	Clamp					8	8	8	8				8	8	8	8
30	805677	Hydrostatic coupling (less Item 21) S/N: 752071 & ABOVE					1	1	1	1				1	1	1	1
31	- - - -	omitted															
32	508802	Plate, pump mounting					1	1	1	1				1	1	1	1
33	803271	Hose assembly, hydrostatic supply					1	1	1	1				1	1	1	1
34	807688	Hose assembly, pump to motor					1	1	1	1				1	1	1	1
35	807689	Hose assembly, pump to motor					1	1	1	1				1	1	1	1
36	802898	Hose, pump 't'- motor 't'					1	1	1	1				1	1	1	1
37	- - - -	omitted															
38	- - - -	omitted															
39	- - - -	omitted															
40	- - - -	omitted															
41	804612	Hose assembly					1	1	1	1				1	1	1	1
42	803275	Hose assembly, pump 'x1'- motor'x2'					2	2	2	2				2	2	2	2
43	804611	Hose assembly, pump 'x2'- motor'x1'					1	1	1	1				1	1	1	1
44	R18147-5	Connector					2	2	2	2				2	2	2	2
45	425330	Strap and bolt kit (2 straps, 4 bolts)					2	2	2	2				2	2	2	2
55	29475	Bolt					4	4	4	4				4	4	4	4
57	42813	Nut					4	4	4	4				4	4	4	4
58	168365	Bolt					4	4	4	4				4	4	4	4
59	809796	Plate					1	1	1	1				1	1	1	1
60	809795	Hub, spline					1	1	1	1				1	1	1	1
61	K97615	Snap ring					1	1	1	1				1	1	1	1

4 AB 151
TIER III

HYDROSTATIC (TRANSMISSION) SYSTEM ASSEMBLY 2

M30-2T H	M30-4T H
M40-2T H	M40-4T H
M50-2T H	M50-4T H

M30-2T H L	M30-4T H L
M40-2T H L	M40-4T H L
M50-2T H L	M50-4T H L

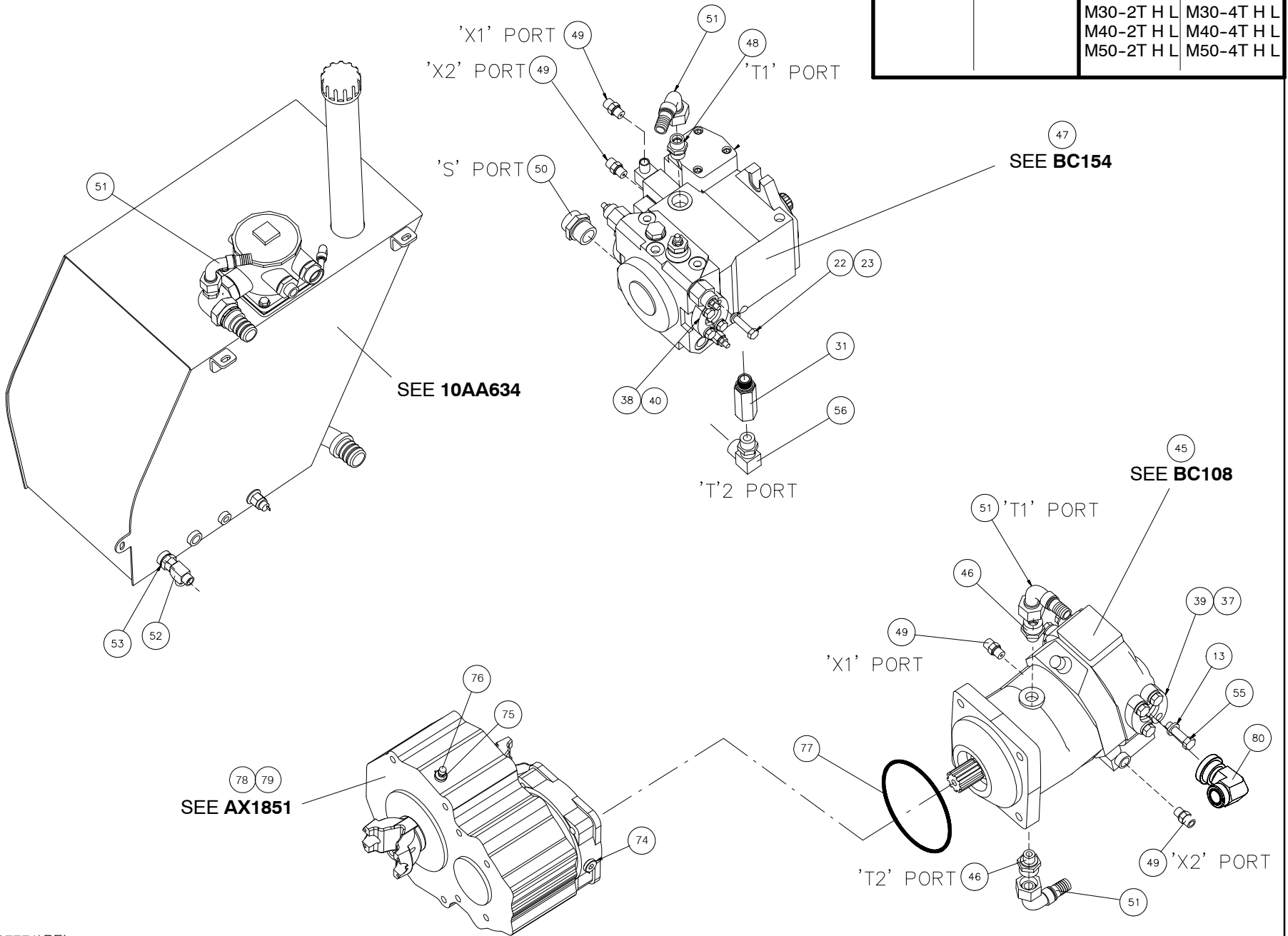

1	HYDROSTATIC (TRANSMISSION) SYSTEM ASSEMBLY 2		QUANTITY / MODEL								4 AB 151				
											M30-4T H	M40-4T H	M50-4T H		M30-4T HL
ITEM	PART NO.	DESCRIPTION	M30-2T H	M40-2T H	M50-2T H					M30-2T HL	M40-2T HL	M50-2T HL			
13	42231	Washer, lock	8	8	8	8				8	8	8	8		
22	42232	Washer, lock	8	8	8	8				8	8	8	8		
23	168351	Bolt	8	8	8	8				8	8	8	8		
31	803886	Check valve, 3 bar	1	1	1	1				1	1	1	1		
37	803611	O-ring -16	2	2	2	2				2	2	2	2		
38	803566	Split flange -12	4	4	4	4				4	4	4	4		
39	803570	Split flange -16	4	4	4	4				4	4	4	4		
40	803585	O-ring -12	2	2	2	2				2	2	2	2		
45	208701	Hydrostatic motor	1	1	1	1				1	1	1	1		
46	234267	Adapter	2	2	2	2				2	2	2	2		
47	807801	Pump, hydrostatic	1	1	1	1				1	1	1	1		
48	524789	Adapter	1	1	1	1				1	1	1	1		
49	806955	Connector	4	4	4	4				4	4	4	4		
50	803270	Connector	1	1	1	1				1	1	1	1		
51	208561	Fitting	4	4	4	4				4	4	4	4		
52	R19829-1	Tee, swivel run	1	1	1	1				1	1	1	1		
53	803026	Connector	1	1	1	1				1	1	1	1		
55	29475	Bolt	8	8	8	8				8	8	8	8		
56	R19452	Elbow	1	1	1	1				1	1	1	1		
74	804128	Plug	1	1	1	1				1	1	1	1		
75	804130	Plug, tapped	1	1	1	1				1	1	1	1		
76	420431	Breather valve	1	1	1	1				1	1	1	1		
77	564073	O-ring	1	1	1	1				1	1	1	1		
78	801992	Gearbox assembly, 6 & 8 K	1	1						1	1				
79	226148	Gearbox assembly, 10 & 12 K				1	1					1	1		
80	807675	Elbow	1	1	1	1				1	1	1	1		

4 AB 152
TIER III

HYDROSTATIC INCHING VALVE, TH7
HYDROSTATIC GEARBOX HYDRAULICS

M30-2T H	M30-4T H
M40-2T H	M40-4T H
M50-2T H	M50-4T H

M30-2T H L	M30-4T H L
M40-2T H L	M40-4T H L
M50-2T H L	M50-4T H L

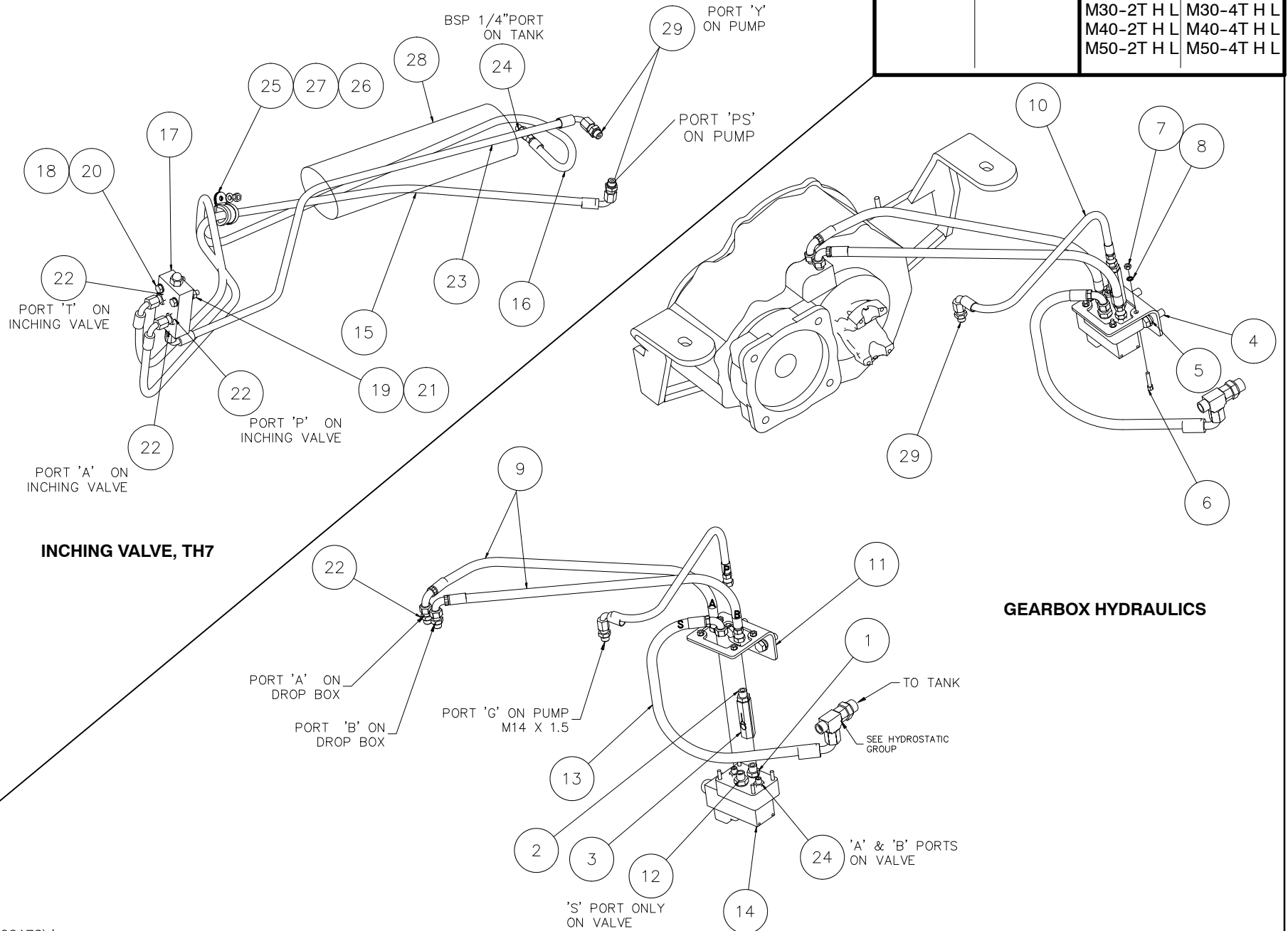

1	HYDROSTATIC GEARBOX HYDRAULICS		QUANTITY / MODEL								4 AB 152				
											M30-4T H	M40-4T H	M50-4T H		M30-4T HL
ITEM	PART NO.	DESCRIPTION	M30-2T H	M40-2T H	M50-2T H					M30-2T HL	M40-2T HL	M50-2T HL			
1	803684	Connector	1	1	1	1				1	1	1	1		
2	803196	Connector	1	1	1	1				1	1	1	1		
3	62179	Check valve	1	1	1	1				1	1	1	1		
4	58546	Bolt	2	2	2	2				2	2	2	2		
5	42231	Washer	2	2	2	2				2	2	2	2		
6	168706	Screw	4	4	4	4				4	4	4	4		
7	25714	Nut	4	4	4	4				4	4	4	4		
8	174132	Washer	4	4	4	4				4	4	4	4		
9	803175	Hose assembly	2	2	2	2				2	2	2	2		
10	805118	Hose assembly	1	1	1	1				1	1	1	1		
11	802504	Plate, valve support	1	1	1	1				1	1	1	1		
12	803174	Connector	1	1	1	1				1	1	1	1		
13	803180	Hose assembly	1	1	1	1				1	1	1	1		
14	60998	Electrovalve	1	1	1	1				1	1	1	1		
15	805120	Hose assembly	1	1	1	1				1	1	1	1		
16	803185	Hose assembly	1	1	1	1				1	1	1	1		
17	75498	Valve, TH7	1	1	1	1				1	1	1	1		
18	61674	Washer	4	4	4	4				4	4	4	4		
19	58528	Nut	2	2	2	2				2	2	2	2		
20	58531	Bolt	2	2	2	2				2	2	2	2		
21	42325	Washer	2	2	2	2				2	2	2	2		
22	803182	Connector	5	5	5	5				5	5	5	5		
23	805119	Hose assembly	1	1	1	1				1	1	1	1		
24	803184	Connector	3	3	3	3				3	3	3	3		
25	86506	Clamp	1	1	1	1				1	1	1	1		
26	K55691	Nut	1	1	1	1				1	1	1	1		
27	K44722	Washer	1	1	1	1				1	1	1	1		
28	Z4525	Sleeve, hose x 60"	1	1	1	1				1	1	1	1		
29	805121	Connector	3	3	3	3				3	3	3	3		

13.00

4 AC 223
TIER III

FUEL TANK ASSEMBLY

M30-2T	M30-4T	M30-2T H	M30-4T H
M40-2T	M40-4T	M40-2T H	M40-4T H
M50-2T	M50-4T	M50-2T H	M50-4T H
M30-2T L	M30-4T L	M30-2T H L	M30-4T H L
M40-2T L	M40-4T L	M40-2T H L	M40-4T H L
M50-2T L	M50-4T L	M50-2T H L	M50-4T H L

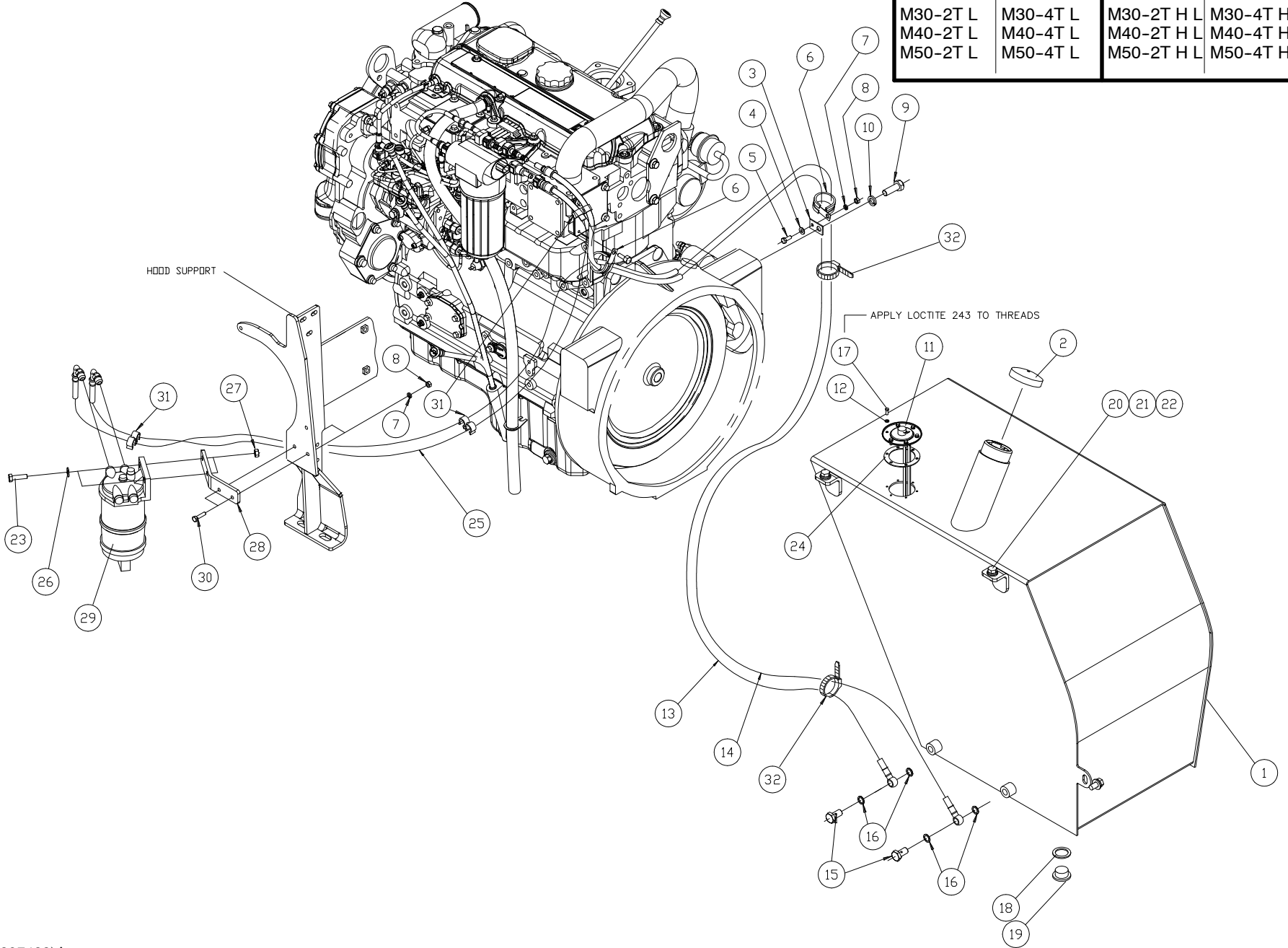

1	FUEL TANK ASSEMBLY		QUANTITY / MODEL											4 AC 223			
			M30-4T	M40-4T	M50-4T		M30-4T H	M40-4T H	M50-4T H		M30-4T L	M40-4T L	M50-4T L		M30-4T HL	M40-4T HL	M50-4T HL
ITEM	PART NO.	DESCRIPTION	M30-2T	M40-2T	M50-2T		M30-2T H	M40-2T H	M50-2T H		M30-2T L	M40-2T L	M50-2T L		M30-2T HL	M40-2T HL	M50-2T HL
1	807434	Fuel tank	1	1	1	1	1	1	1	1	1	1	1	1	1	1	1
2	806421	Fuel cap	1	1	1	1	1	1	1	1	1	1	1	1	1	1	1
3	807440	Plate	1	1	1	1	1	1	1	1	1	1	1	1	1	1	1
4	29469	Washer	1	1	1	1	1	1	1	1	1	1	1	1	1	1	1
5	25713	Bolt	1	1	1	1	1	1	1	1	1	1	1	1	1	1	1
6	B3698-15	Clamp	2	2	2	2	2	2	2	2	2	2	2	2	2	2	2
7	42316	Washer	3	3	3	3	3	3	3	3	3	3	3	3	3	3	3
8	25714	Nut	3	3	3	3	3	3	3	3	3	3	3	3	3	3	3
9	63546	Bolt	1	1	1	1	1	1	1	1	1	1	1	1	1	1	1
10	42231	Washer	1	1	1	1	1	1	1	1	1	1	1	1	1	1	1
11	187283	Sender, fuel level	1	1	1	1	1	1	1	1	1	1	1	1	1	1	1
12	187294	Washer	6	6	6	6	6	6	6	6	6	6	6	6	6	6	6
13	273244	Hose assembly	1	1	1	1	1	1	1	1	1	1	1	1	1	1	1
14	273248	Hose assembly	1	1	1	1	1	1	1	1	1	1	1	1	1	1	1
15	129397	Screw, banjo	2	2	2	2	2	2	2	2	2	2	2	2	2	2	2
16	3411	Washer, seal	4	4	4	4	4	4	4	4	4	4	4	4	4	4	4
17	802288	Bolt	6	6	6	6	6	6	6	6	6	6	6	6	6	6	6
18	189536	Seal, drain plug	1	1	1	1	1	1	1	1	1	1	1	1	1	1	1
19	189535	Drain plug	1	1	1	1	1	1	1	1	1	1	1	1	1	1	1
20	29437	Washer	3	3	3	3	3	3	3	3	3	3	3	3	3	3	3
21	42232	Washer, lock	3	3	3	3	3	3	3	3	3	3	3	3	3	3	3
22	63727	Bolt	3	3	3	3	3	3	3	3	3	3	3	3	3	3	3
23	57446	Bolt	2	2	2	2	2	2	2	2	2	2	2	2	2	2	2
24	187485	Gasket	1	1	1	1	1	1	1	1	1	1	1	1	1	1	1
25	273250	Hose	1	1	1	1	1	1	1	1	1	1	1	1	1	1	1
26	61674	Washer	2	2	2	2	2	2	2	2	2	2	2	2	2	2	2
27	58528	Nut	2	2	2	2	2	2	2	2	2	2	2	2	2	2	2
28	807441	Support	1	1	1	1	1	1	1	1	1	1	1	1	1	1	1
29	254561	Fuel/water separator	1	1	1	1	1	1	1	1	1	1	1	1	1	1	1

5 AA 101
TIER III

MAST MOUNTING HARDWARE

M30-2T	M30-4T	M30-2T H	M30-4T H
M40-2T	M40-4T	M40-2T H	M40-4T H
M50-2T	M50-4T	M50-2T H	M50-4T H
M30-2T L	M30-4T L	M30-2T H L	M30-4T H L
M40-2T L	M40-4T L	M40-2T H L	M40-4T H L
M50-2T L	M50-4T L	M50-2T H L	M50-4T H L

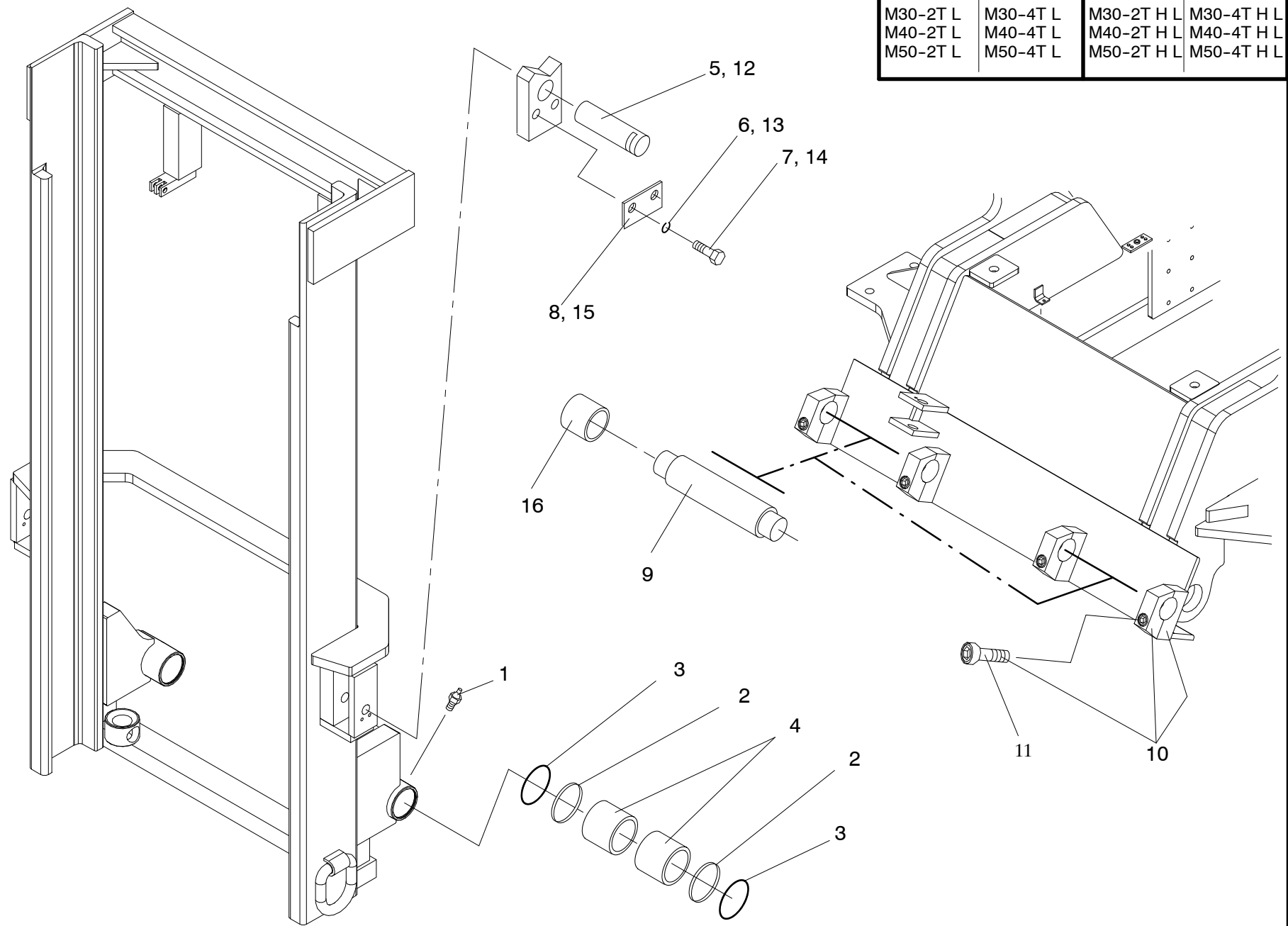

1	MAST MOUNTING HARDWARE		QUANTITY / MODEL											5 AA 101				
			M30-4T	M40-4T	M50-4T		M30-4T H	M40-4T H	M50-4T H		M30-4T L	M40-4T L	M50-4T L		M30-4T HL	M40-4T HL	M50-4T HL	
ITEM	PART NO.	DESCRIPTION	M30-2T	M40-2T	M50-2T		M30-2T H	M40-2T H	M50-2T H		M30-2T L	M40-2T L	M50-2T L		M30-2T HL	M40-2T HL	M50-2T HL	
1	K87901	Grease fitting	2	2	2	2	2	2	2	2	2	2	2	2	2	2	2	2
2	R106	Ring, retaining	4	4	4	4	4	4	4	4	4	4	4	4	4	4	4	4
3	R4584	Wiper	4	4	4	4	4	4	4	4	4	4	4	4	4	4	4	4
4	R7638	Bearing, mast mounting	4	4	4	4	4	4	4	4	4	4	4	4	4	4	4	4
5*	R25454	Pin	2	2	2	2	2	2	2	2	2	2	2	2	2	2	2	2
6*	K34807	Washer, lock	4	4	4	4	4	4	4	4	4	4	4	4	4	4	4	4
7*	K20388	Bolt	4	4	4	4	4	4	4	4	4	4	4	4	4	4	4	4
8*	R25456	Plate, pin retaining	2	2	2	2	2	2	2	2	2	2	2	2	2	2	2	2
9	B5407	Bar, mast support	2	2	2	2	2	2	2	2	2	2	2	2	2	2	2	2
10	B5795	Cap and base assembly - Welding required, must show proof of certification	4	4	4	4	4	4	4	4	4	4	4	4	4	4	4	4
11	B6119	Bolt	4	4	4	4	4	4	4	4	4	4	4	4	4	4	4	4
12**	77399	Pin	2	2	2	2	2	2	2	2	2	2	2	2	2	2	2	2
13**	42232	Washer, lock	2	2	2	2	2	2	2	2	2	2	2	2	2	2	2	2
14**	63727	Bolt	4	4	4	4	4	4	4	4	4	4	4	4	4	4	4	4
15**	165363	Plate, pin retaining	2	2	2	2	2	2	2	2	2	2	2	2	2	2	2	2
16	807813	Spacer, side shift lock out	4	4	4	4	4	4	4	4	4	4	4	4	4	4	4	4

*For use with "K" Model Masts
**For use with "800000" Model Masts

6 AA 367
TIER III

FRAME AND COUNTERWEIGHTS

M30-2T	M30-4T	M30-2T H	M30-4T H
M40-2T	M40-4T	M40-2T H	M40-4T H
M50-2T	M50-4T	M50-2T H	M50-4T H
M30-2T L	M30-4T L	M30-2T H L	M30-4T H L
M40-2T L	M40-4T L	M40-2T H L	M40-4T H L
M50-2T L	M50-4T L	M50-2T H L	M50-4T H L

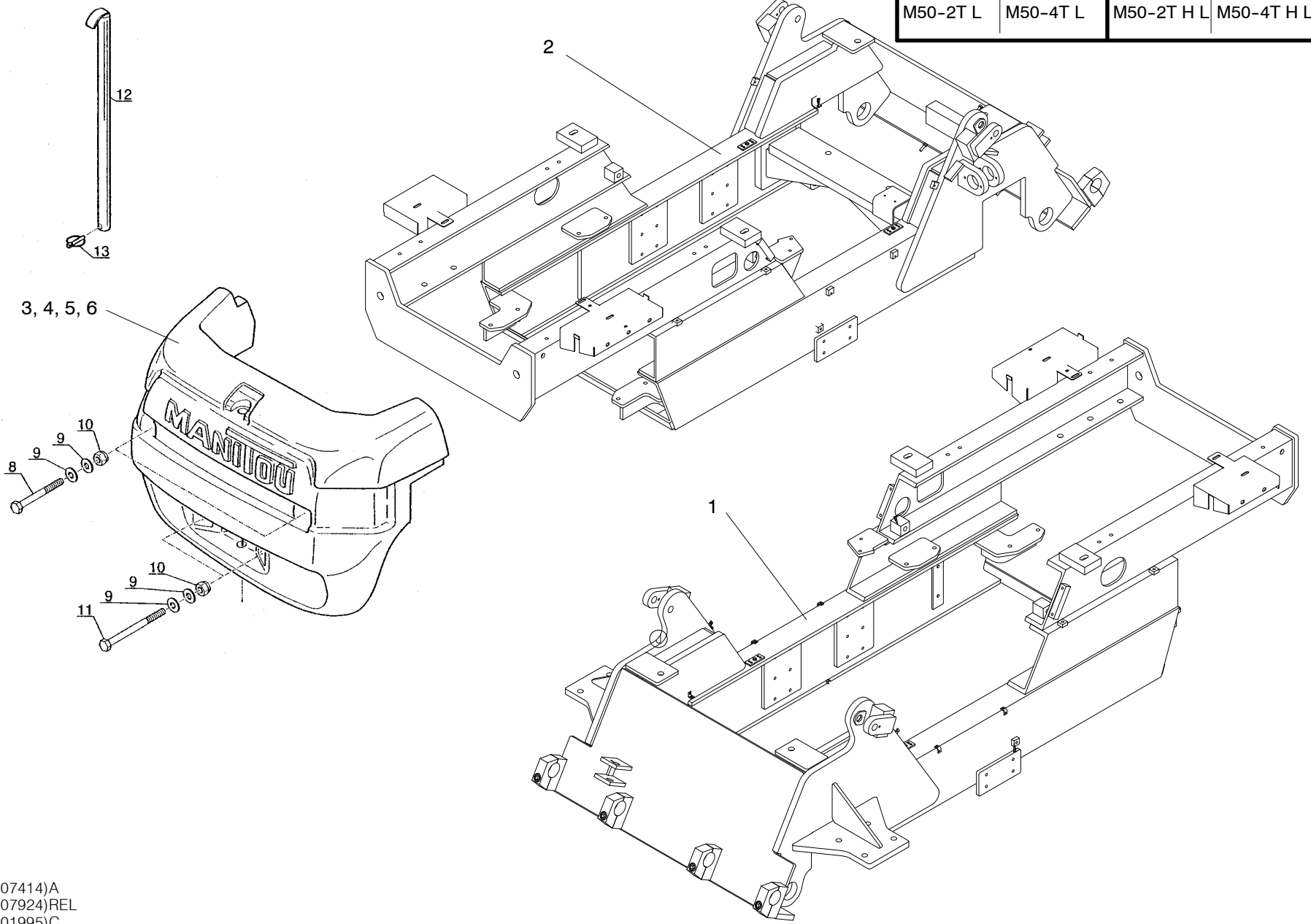

807414)A
807924)REL
801995)C

1	FRAME AND COUNTERWEIGHTS		QUANTITY / MODEL									6 AA 367																
			M30-2T	M30-4T	M40-2T	M40-4T	M50-2T	M50-4T	M30-2T H	M30-4T H	M40-2T H	M40-4T H	M50-2T H	M50-4T H	M30-2T L	M30-4T L	M40-2T L	M40-4T L	M50-2T L	M50-4T L	M30-2T HL	M30-4T HL	M40-2T HL	M40-4T HL	M50-2T HL	M50-4T HL		
ITEM	PART NO.	DESCRIPTION																										
1	807414	Frame (ALL, EXCEPT FRAME LEVELING)	1					1																				
2	807924	Frame (FRAME LEVELING ONLY)												1	1	1	1							1	1	1	1	
3	218177	Counterweight	1					1						1									1					
4	218178	Counterweight		1					1						1									1				
5	218179	Counterweight			1					1						1									1			
6	218180	Counterweight				1					1						1									1		
8	75992	Screw	2	2	2	2	2	2	2	2	2	2	2	2	2	2	2	2	2	2	2	2	2	2	2	2	2	2
9	63936	Washer	8	8	8	8	8	8	8	8	8	8	8	8	8	8	8	8	8	8	8	8	8	8	8	8	8	8
10	184642	Nut	4	4	4	4	4	4	4	4	4	4	4	4	4	4	4	4	4	4	4	4	4	4	4	4	4	4
11	168379	Screw	2	2	2	2	2	2	2	2	2	2	2	2	2	2	2	2	2	2	2	2	2	2	2	2	2	2
12	219518	Towing spindle	1					1						1									1					
12	218265	Towing spindle		1	1	1			1	1	1				1	1	1							1	1	1		
13	32963	Pin	1	1	1	1	1	1	1	1	1	1	1	1	1	1	1	1	1	1	1	1	1	1	1	1	1	1
14	44807	Bolt,	4	4	4	4	4	4	4	4	4	4	4	4	4	4	4	4	4	4	4	4	4	4	4	4	4	4

6 AA 375
TIER III

SIDE STEP INSTALLATION

M30-2T	M30-4T	M30-2T H	M30-4T H
M40-2T	M40-4T	M40-2T H	M40-4T H
M50-2T	M50-4T	M50-2T H	M50-4T H
M30-2T L	M30-4T L	M30-2T H L	M30-4T H L
M40-2T L	M40-4T L	M40-2T H L	M40-4T H L
M50-2T L	M50-4T L	M50-2T H L	M50-4T H L

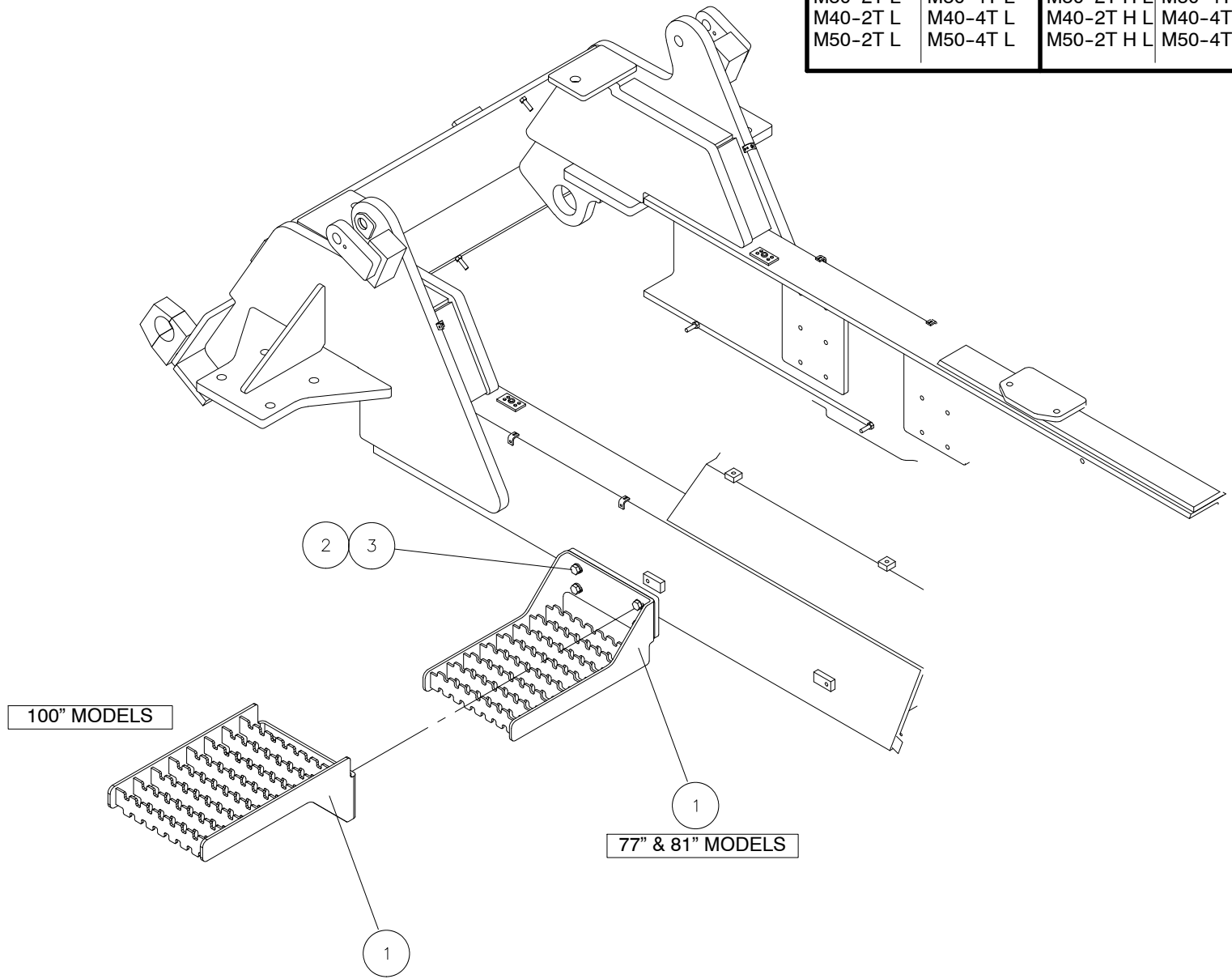

1	SIDE STEP INSTALLATION			QUANTITY / MODEL									6 AA 375					
				M30-4T	M40-4T	M50-4T		M30-4T H	M40-4T H	M50-4T H		M30-4T L	M40-4T L	M50-4T L		M30-4T HL	M40-4T HL	M50-4T HL
ITEM	PART NO.	DESCRIPTION	M30-2T	M40-2T	M50-2T		M30-2T H	M40-2T H	M50-2T H		M30-2T L	M40-2T L	M50-2T L		M30-2T HL	M40-2T HL	M50-2T HL	
1	807492	Step assembly, all models	2	2	2	2	2	2	2	2	2	2	2	2	2	2	2	2
2	42231	Washer	8	8	8	8	8	8	8	8	8	8	8	8	8	8	8	8
3	63546	Bolt	8	8	8	8	8	8	8	8	8	8	8	8	8	8	8	8

6 AA 376
TIER III

**FRONT DRIVE AXLE AND DRIVESHAFT INSTALLATION
(EXCEPT FRAME LEVELING)**

M30-2T	M30-4T	M30-2T H	M30-4T H
M40-2T	M40-4T	M40-2T H	M40-4T H
M50-2T	M50-4T	M50-2T H	M50-4T H

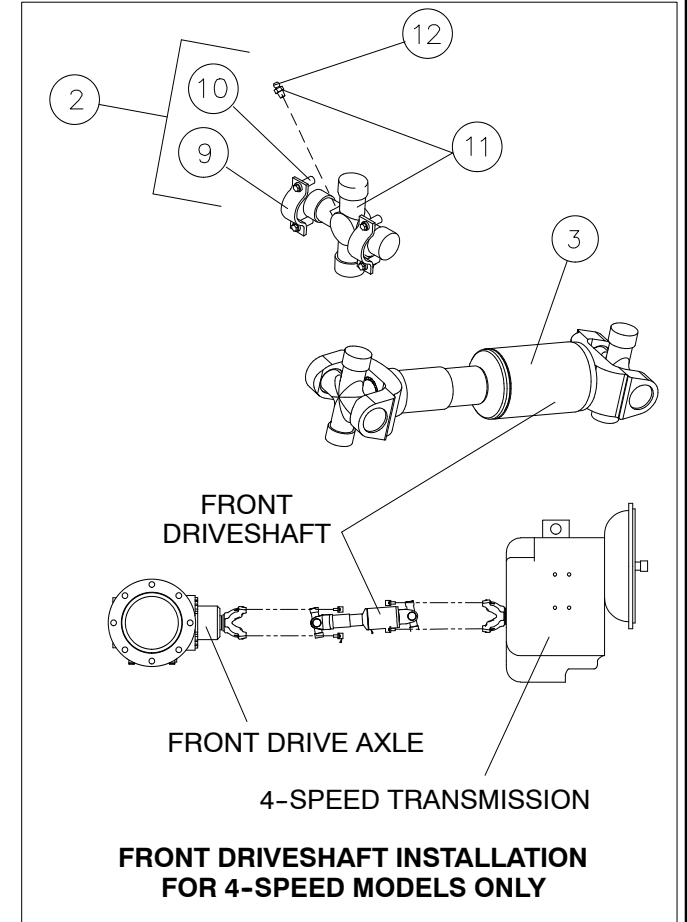
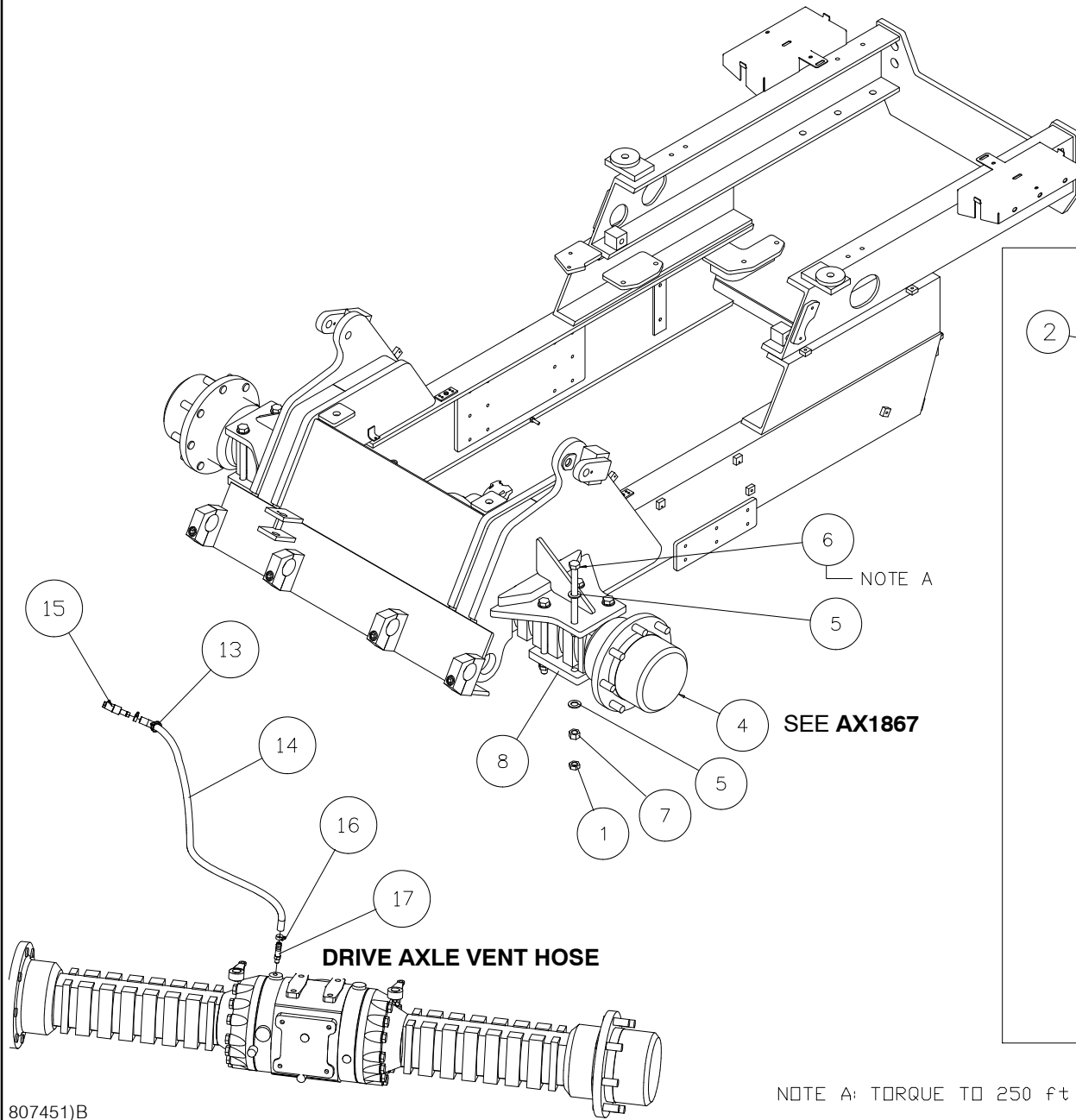

NOTE A: TORQUE TO 250 ft lbs.

			QUANTITY / MODEL							6 AA 376					
1 FRONT DRIVE AXLE INSTALLATION (EXCEPT FRAME LEVELING)			M30-4T	M40-4T	M50-4T		M30-4T H	M40-4T H	M50-4T H						
ITEM	PART NO.	DESCRIPTION	M30-2T	M40-2T	M50-2T		M30-2T H	M40-2T H	M50-2T H						
1	K34691	Nut, jam	8	8	8	8	8	8	8	8					
2	425330	Strap and bolt kit (4-SPEED MODELS ONLY)	2	2	2	2	2	2	2	2					
3	802047	Driveshaft, front (4-SPEED MODELS ONLY)	1	1	1	1	1	1	1	1					
4	807371	Axle, front drive	1	1	1	1	1	1	1	1					
5	K44748	Washer, flat	16	16	16	16	16	16	16	16					
6	804828	Bolt	8	8	8	8	8	8	8	8					
7	K34992	Nut	8	8	8	8	8	8	8	8					
8	803560	Plate, axle mount	2	2	2	2	2	2	2	2					
9	109751	Clamp half	4	4	4	4	4	4	4	4					
10	109752	Bolt	8	8	8	8	8	8	8	8					
11	424647	U-joint	2	2	2	2	2	2	2	2					
12	162809	Zerk, grease fitting	2	2	2	2	2	2	2	2					
13	B3698-8	Clamp	1	1	1	1	1	1	1	1					
14	525596	Hose	1	1	1	1	1	1	1	1					
15	222381	Breather	1	1	1	1	1	1	1	1					
16	B2236-3	Clamp	2	2	2	2	2	2	2	2					
17	254733	Connector	1	1	1	1	1	1	1	1					

6 AA 377
TIER III

**FRONT DRIVE AXLE AND DRIVESHAFT INSTALLATION
(FRAME LEVELING)**

M30-2T L	M30-4T L	M30-2T H L	M30-4T H L
M40-2T L	M40-4T L	M40-2T H L	M40-4T H L
M50-2T L	M50-4T L	M50-2T H L	M50-4T H L

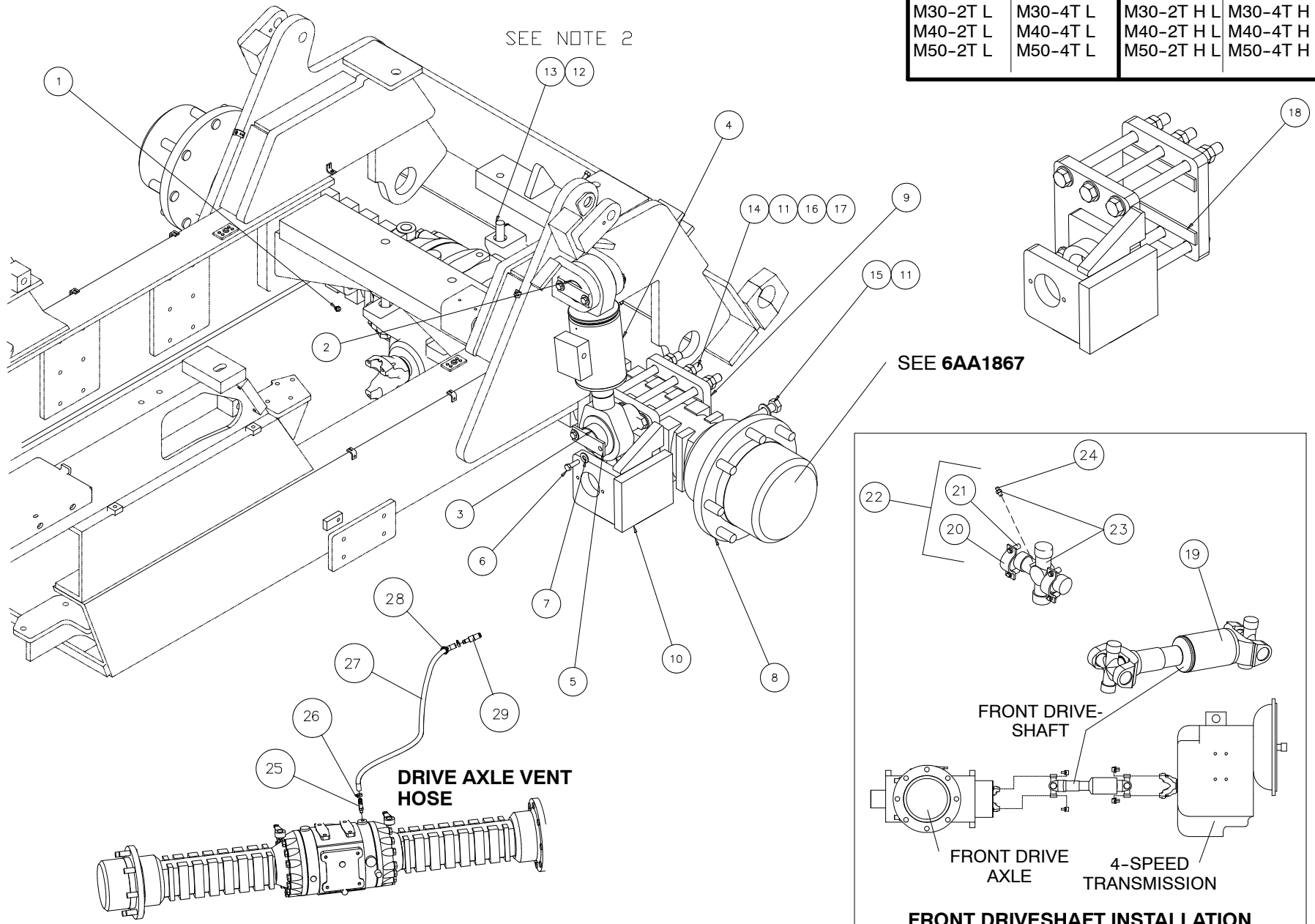

- NOTES 1. ADJUST CYLINDER TO $\pm 5^\circ$ TILT.
2. APPLY LOCTITE 242 TO ITEM 13.

**FRONT DRIVESHAFT INSTALLATION
FOR 4-SPEED MODELS ONLY**

1	FRONT DRIVE AXLE INSTALLATION (FRAME LEVELING)		QUANTITY / MODEL									6 AA 377							
												M30-4T L	M40-4T L	M50-4T L	M30-4T HL	M40-4T HL	M50-4T HL		
ITEM	PART NO.	DESCRIPTION											M30-2T L	M40-2T L	M50-2T L	M30-2T HL	M40-2T HL	M50-2T HL	
1	T51534	Grease fitting											3	3	3	3	3	3	3
2	803229	Pin											1	1	1	1	1	1	1
3	801924	Pin											1	1	1	1	1	1	1
4	803617	Cylinder, frame leveling											1	1	1	1	1	1	1
5	803614	Plate											3	3	3	3	3	3	3
6	K20428	Bolt											6	6	6	6	6	6	6
7	K44728	Washer											6	6	6	6	6	6	6
8	807926	Axle assembly, frame leveling											1	1	1	1	1	1	1
9	807290	Plate											1	1	1	1	1	1	1
10	807291	Cylinder mount											1	1	1	1	1	1	1
11	426650	Washer											10	10	10	10	10	10	10
12	61683	Washer											4	4	4	4	4	4	4
13	58633	Bolt											4	4	4	4	4	4	4
14	426648	Bolt											4	4	4	4	4	4	4
15	K58758	Bolt											2	2	2	2	2	2	2
16	426649	Nut											4	4	4	4	4	4	4
17	K34691	Nut											4	4	4	4	4	4	4
18	807485	Strip											2	2	2	2	2	2	2
19	802047	Drive shaft, front											1	1	1	1	1	1	1
20	109751	Clamp half											4	4	4	4	4	4	4
21	109752	Bolt											8	8	8	8	8	8	8
22	425330	Strap and bolt kit											2	2	2	2	2	2	2
23	424647	U-joint											2	2	2	2	2	2	2
24	162809	Zerk, grease fitting											2	2	2	2	2	2	2
25	254733	Connector											1	1	1	1	1	1	1
26	B2236-3	Clamp											2	2	2	2	2	2	2
27	525596	Hose											1	1	1	1	1	1	1
28	B3698-8	Clamp											1	1	1	1	1	1	1
29	222381	Breather											1	1	1	1	1	1	1

19.00

6 AA 372
TIER III

CYLINDER, FRAME LEVELING, INSTALLATION

M30-2T L	M30-4T L	M30-2T H L	M30-4T H L
M40-2T L	M40-4T L	M40-2T H L	M40-4T H L
M50-2T L	M50-4T L	M50-2T H L	M50-4T H L

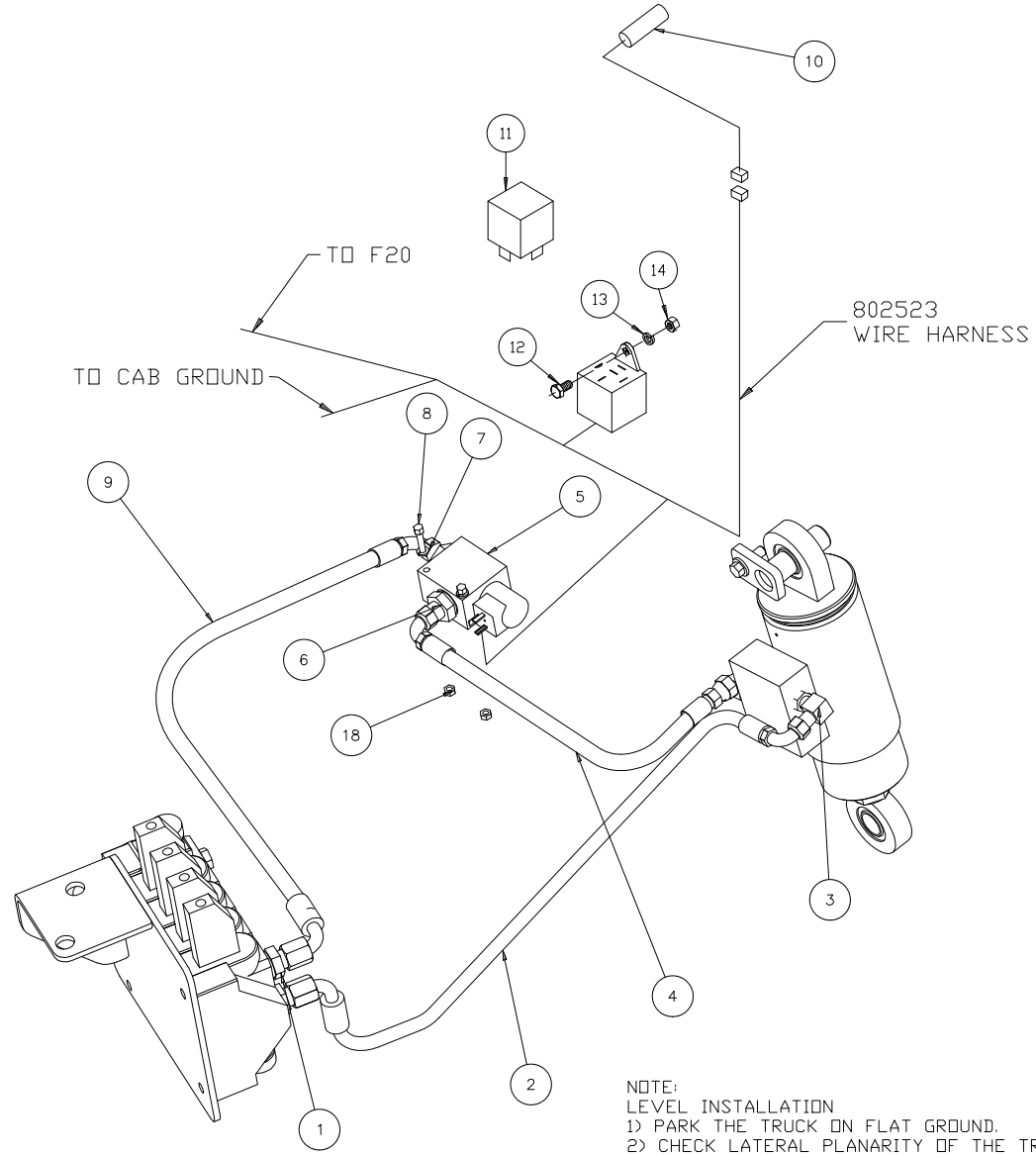

COVER SHOWN FROM BACK

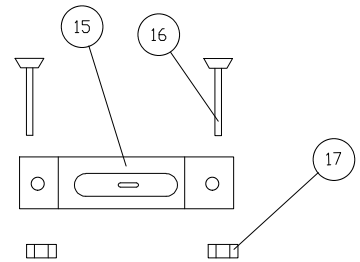
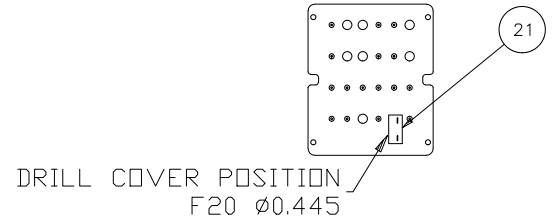

NOTE:
LEVEL INSTALLATION
1) PARK THE TRUCK ON FLAT GROUND.
2) CHECK LATERAL PLANARITY OF THE TRUCK USING LEVEL INDICATOR ON AT LEAST 3 PLANAR SURFACES. EX: FRAME OR FENDERS
3) ONCE TRUCK IS LEVELLED, INSTALL THE LEVEL GAUGE (#448834) ON DASH WHERE VISIBLE TO OPERATOR IN SEATED POSITION.

1	CYLINDER, FRAME LEVELING, INSTALLATION		QUANTITY / MODEL									6 AA 372						
												M30-4T L	M40-4T L	M50-4T L	M30-4T HL	M40-4T HL	M50-4T HL	
ITEM	PART NO.	DESCRIPTION																
			M30-2T L	M40-2T L	M50-2T L								M30-2T HL	M40-2T HL	M50-2T HL			
1	803288	Orifice assembly	2	2	2	2	2	2	2	2	2	2	2	2	2	2	2	2
2	803289	Hose assembly	1	1	1	1	1	1	1	1	1	1	1	1	1	1	1	1
3	M0001183	Adapter	2	2	2	2	2	2	2	2	2	2	2	2	2	2	2	2
4	803290	Hose assembly	1	1	1	1	1	1	1	1	1	1	1	1	1	1	1	1
5	224826	Valve, solenoid	1	1	1	1	1	1	1	1	1	1	1	1	1	1	1	1
6	803188	Connector	2	2	2	2	2	2	2	2	2	2	2	2	2	2	2	2
7	42316	Washer	2	2	2	2	2	2	2	2	2	2	2	2	2	2	2	2
8	31007	Screw	2	2	2	2	2	2	2	2	2	2	2	2	2	2	2	2
9	803291	Hose assembly	1	1	1	1	1	1	1	1	1	1	1	1	1	1	1	1
10	802932	Proximity switch	1	1	1	1	1	1	1	1	1	1	1	1	1	1	1	1
11	806876	Relay	1	1	1	1	1	1	1	1	1	1	1	1	1	1	1	1
12	79533	Screw	1	1	1	1	1	1	1	1	1	1	1	1	1	1	1	1
13	28959	Washer	1	1	1	1	1	1	1	1	1	1	1	1	1	1	1	1
14	54232	Nut	1	1	1	1	1	1	1	1	1	1	1	1	1	1	1	1
15	448834	Level indicator	1	1	1	1	1	1	1	1	1	1	1	1	1	1	1	1
16	478547	Screw	2	2	2	2	2	2	2	2	2	2	2	2	2	2	2	2
17	25758	Nut	2	2	2	2	2	2	2	2	2	2	2	2	2	2	2	2
18	25714	Nut	2	2	2	2	2	2	2	2	2	2	2	2	2	2	2	2
19*	803042	Support, proximity switch	1	1	1	1	1	1	1	1	1	1	1	1	1	1	1	1
20*	804044	Flat	1	1	1	1	1	1	1	1	1	1	1	1	1	1	1	1
21	804285	Circuit breaker, 5A	1	1	1	1	1	1	1	1	1	1	1	1	1	1	1	1
22*	806962	Guard	1	1	1	1	1	1	1	1	1	1	1	1	1	1	1	1
		* Item not shown (requires welding) request drawing 803286																

6 BA 214
TIER III

BRAKE CIRCUIT, CUTTING, OPTIONAL

M30-2T	M30-4T	M30-2T H	M30-4T H
M40-2T	M40-4T	M40-2T H	M40-4T H
M50-2T	M50-4T	M50-2T H	M50-4T H
M30-2T L	M30-4T L	M30-2T H L	M30-4T H L
M40-2T L	M40-4T L	M40-2T H L	M40-4T H L
M50-2T L	M50-4T L	M50-2T H L	M50-4T H L

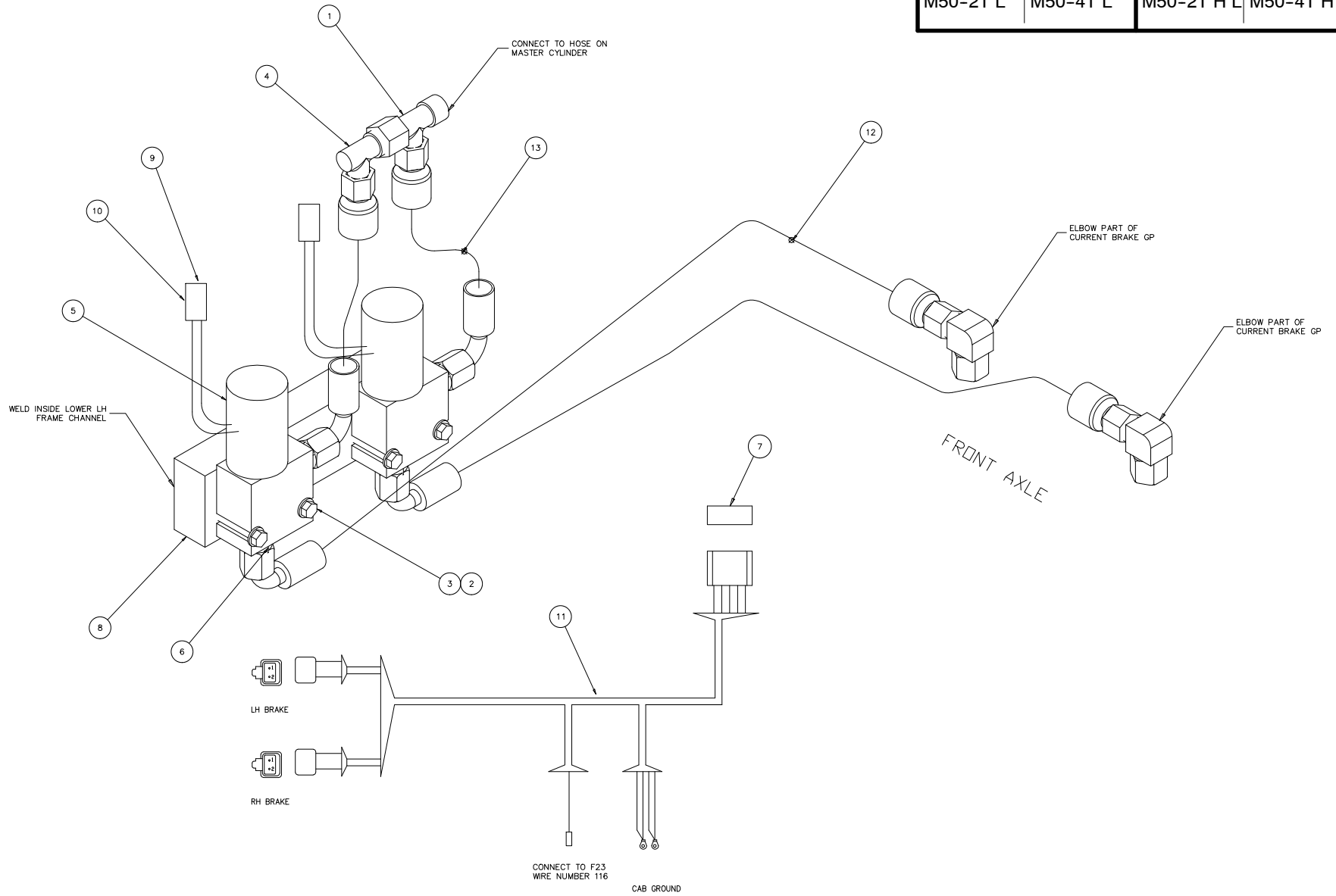

1	BRAKE CIRCUIT, CUTTING, OPTIONAL		QUANTITY / MODEL											6 BA 214			
			M30-4T	M40-4T	M50-4T		M30-4T H	M40-4T H	M50-4T H		M30-4T L	M40-4T L	M50-4T L		M30-4T HL	M40-4T HL	M50-4T HL
ITEM	PART NO.	DESCRIPTION	M30-2T	M40-2T	M50-2T		M30-2T H	M40-2T H	M50-2T H		M30-2T L	M40-2T L	M50-2T L		M30-2T HL	M40-2T HL	M50-2T HL
1	190442	Fitting	1	1	1	1	1	1	1	1	1	1	1	1	1	1	1
2	29469	Washer	4	4	4	4	4	4	4	4	4	4	4	4	4	4	4
3	801532	Bolt	4	4	4	4	4	4	4	4	4	4	4	4	4	4	4
4	802979	Fitting, elbow	1	1	1	1	1	1	1	1	1	1	1	1	1	1	1
5	806371	Valve	2	2	2	2	2	2	2	2	2	2	2	2	2	2	2
6	806372	Fitting	4	4	4	4	4	4	4	4	4	4	4	4	4	4	4
7	806374	Switch	1	1	1	1	1	1	1	1	1	1	1	1	1	1	1
8	806375	Plate	1	1	1	1	1	1	1	1	1	1	1	1	1	1	1
9	805911	Plug, Deutsch	4	4	4	4	4	4	4	4	4	4	4	4	4	4	4
10	805912	Socket, Deutsch	4	4	4	4	4	4	4	4	4	4	4	4	4	4	4
11	806373	Harness	1	1	1	1	1	1	1	1	1	1	1	1	1	1	1
12	806377	Hose assembly	2	2	2	2	2	2	2	2	2	2	2	2	2	2	2
13	806376	Hose assembly	2	2	2	2	2	2	2	2	2	2	2	2	2	2	2

6 BB 160

TIER III

BRAKE SYSTEM ASSEMBLY, HYDRAULIC, 100 IN. CABS

M30-2T	M30-4T	M30-2T H	M30-4T H
M40-2T	M40-4T	M40-2T H	M40-4T H
M50-2T	M50-4T	M50-2T H	M50-4T H
M30-2T L	M30-4T L	M30-2T H L	M30-4T H L
M40-2T L	M40-4T L	M40-2T H L	M40-4T H L
M50-2T L	M50-4T L	M50-2T H L	M50-4T H L

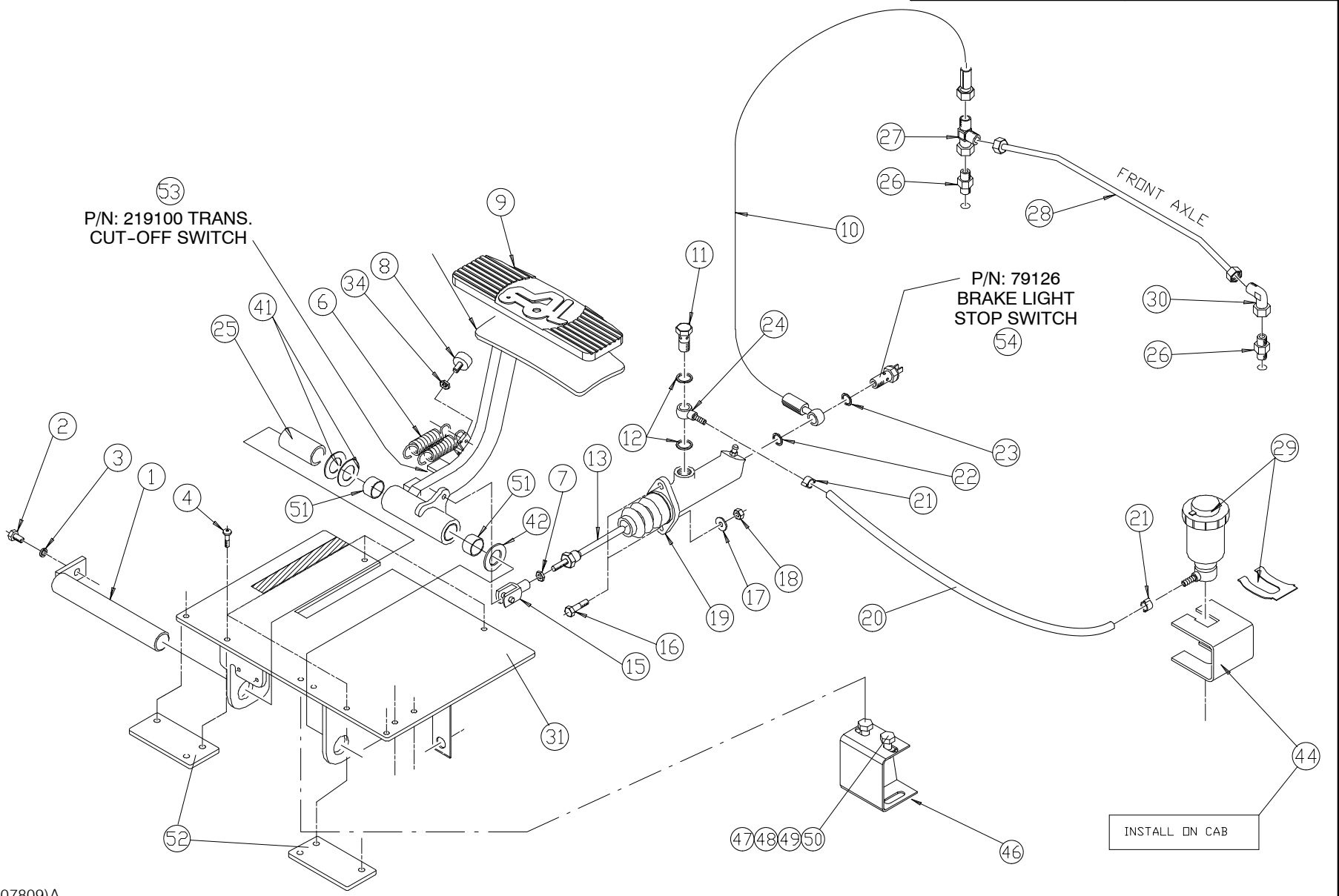

1	BRAKE SYSTEM ASSEMBLY, HYDRAULIC, 100 IN. CABS											6 BB 160						
	ITEM	PART NO.	DESCRIPTION	M30-4T	M40-4T	M50-4T		M30-4T H	M40-4T H	M50-4T H		M30-4T L	M40-4T L	M50-4T L		M30-4T HL	M40-4T HL	M50-4T HL
				M30-2T	M40-2T	M50-2T		M30-2T H	M40-2T H	M50-2T H		M30-2T L	M40-2T L	M50-2T L		M30-2T HL	M40-2T HL	M50-2T HL
1	79412	Pedal axle		1	1	1	1	1	1	1	1	1	1	1	1	1	1	1
2	54951	Bolt		1	1	1	1	1	1	1	1	1	1	1	1	1	1	1
3	42325	Washer		1	1	1	1	1	1	1	1	1	1	1	1	1	1	1
4	189172	Bolt		A/R	A/R	A/R	A/R	A/R	A/R	A/R	A/R	A/R	A/R	A/R	A/R	A/R	A/R	A/R
5	802780	Brake pedal		1	1	1	1	1	1	1	1	1	1	1	1	1	1	1
6	5398	Spring		2	2	2	2	2	2	2	2	2	2	2	2	2	2	2
7	56354	Nut		1	1	1	1	1	1	1	1	1	1	1	1	1	1	1
8	53501	Rubber stop		1	1	1	1	1	1	1	1	1	1	1	1	1	1	1
9	240821	Pad, pedal cover		1	1	1	1	1	1	1	1	1	1	1	1	1	1	1
10	217947	Brake hose		1	1	1	1	1	1	1	1	1	1	1	1	1	1	1
11	218074	Bolt, hollow		1	1	1	1	1	1	1	1	1	1	1	1	1	1	1
12	80305	Seal		2	2	2	2	2	2	2	2	2	2	2	2	2	2	2
13	219834	Master cylinder rod		1	1	1	1	1	1	1	1	1	1	1	1	1	1	1
15	5549	Short clevis		1	1	1	1	1	1	1	1	1	1	1	1	1	1	1
16	K20386SS	Bolt		2	2	2	2	2	2	2	2	2	2	2	2	2	2	2
17	K34806SS	Washer		2	2	2	2	2	2	2	2	2	2	2	2	2	2	2
18	K33922	Nut		1	1	1	1	1	1	1	1	1	1	1	1	1	1	1
19	271498	Master cylinder		1	1	1	1	1	1	1	1	1	1	1	1	1	1	1
20	802781	Hose		1	1	1	1	1	1	1	1	1	1	1	1	1	1	1
21	479218	Hose clamp		2	2	2	2	2	2	2	2	2	2	2	2	2	2	2
22	233837	Seal		1	1	1	1	1	1	1	1	1	1	1	1	1	1	1
23	81044	Seal		1	1	1	1	1	1	1	1	1	1	1	1	1	1	1
24	218075	Banjo fitting		1	1	1	1	1	1	1	1	1	1	1	1	1	1	1
25	79414	Tube		1	1	1	1	1	1	1	1	1	1	1	1	1	1	1
26	175498	Fitting		2	2	2	2	2	2	2	2	2	2	2	2	2	2	2
27	190442	Tee fitting		1	1	1	1	1	1	1	1	1	1	1	1	1	1	1
28	237806	Tube assembly		1	1	1	1	1	1	1	1	1	1	1	1	1	1	1

6 BB 161

TIER II

BRAKE SYSTEM ASSEMBLY, HYDRAULIC, 77 & 81 IN. CAB

M30-2T	M30-4T	M30-2T H	M30-4T H
M40-2T	M40-4T	M40-2T H	M40-4T H
M50-2T	M50-4T	M50-2T H	M50-4T H
M30-2T L	M30-4T L	M30-2T H L	M30-4T H L
M40-2T L	M40-4T L	M40-2T H L	M40-4T H L
M50-2T L	M50-4T L	M50-2T H L	M50-4T H L

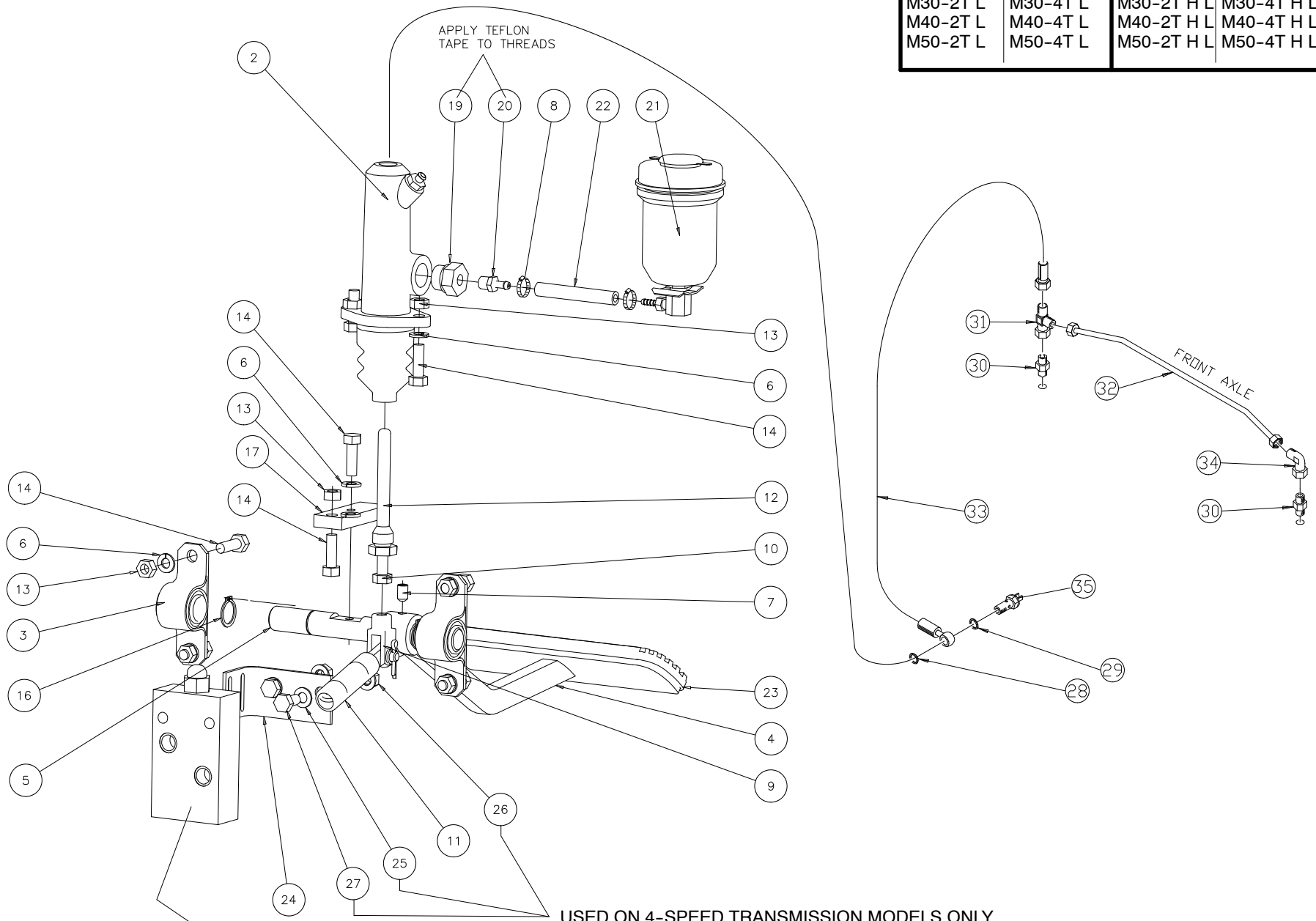

USED ON 4-SPEED TRANSMISSION MODELS ONLY

SHOWN FOR REF. ONLY, USED ON HYDROSTATIC TRANSMISSION MODELS ONLY

1	BRAKE SYSTEM ASSEMBLY, HYDRAULIC, 77 & 81 IN. CAB		QUANTITY / MODEL											6 BB 161			
			M30-4T	M40-4T	M50-4T		M30-4T H	M40-4T H	M50-4T H		M30-4T L	M40-4T L	M50-4T L		M30-4T HL	M40-4T HL	M50-4T HL
ITEM	PART NO.	DESCRIPTION	M30-2T	M40-2T	M50-2T		M30-2T H	M40-2T H	M50-2T H		M30-2T L	M40-2T L	M50-2T L		M30-2T HL	M40-2T HL	M50-2T HL
2	271498	Brake master cylinder	1	1	1	1	1	1	1	1	1	1	1	1	1	1	1
3	801864	Bearing block	2	2	2	2	2	2	2	2	2	2	2	2	2	2	2
4	802876	Brake pedal	1	1	1	1	1	1	1	1	1	1	1	1	1	1	1
5	801885	Pin, brake assembly	1	1	1	1	1	1	1	1	1	1	1	1	1	1	1
6	K34806SS	Washer	7	7	7	7	7	7	7	7	7	7	7	7	7	7	7
7	K89778	Screw	2	2	2	2	2	2	2	2	2	2	2	2	2	2	2
8	479218	Clamp	1	1	1	1	1	1	1	1	1	1	1	1	1	1	1
9	5549	Clevis assembly	1	1	1	1	1	1	1	1	1	1	1	1	1	1	1
10	56354	Nut	1	1	1	1	1	1	1	1	1	1	1	1	1	1	1
11	5398	Spring	1	1	1	1	1	1	1	1	1	1	1	1	1	1	1
12	219834	Master cylinder rod	1	1	1	1	1	1	1	1	1	1	1	1	1	1	1
13	K33922	Nut	7	7	7	7	7	7	7	7	7	7	7	7	7	7	7
14	K20386SS	Bolt	8	8	8	8	8	8	8	8	8	8	8	8	8	8	8
15	-----	Omitted															
16	K97524	Ring	2	2	2	2	2	2	2	2	2	2	2	2	2	2	2
17	801886	Tab, inching valve	1	1	1	1	1	1	1	1	1	1	1	1	1	1	1
18	-----	Omitted															
19	802054	Adapter	1	1	1	1	1	1	1	1	1	1	1	1	1	1	1
20	B3500	Adapter	1	1	1	1	1	1	1	1	1	1	1	1	1	1	1
21	219559	Reservoir, brake fluid	1	1	1	1	1	1	1	1	1	1	1	1	1	1	1
22	802779	Hose	1	1	1	1	1	1	1	1	1	1	1	1	1	1	1
23	240821	Pad, pedal cover	1	1	1	1	1	1	1	1	1	1	1	1	1	1	1
24	802010	Angle	1	1	1	1	1	1	1	1	1	1	1	1	1	1	1
25	61674	Washer	4	4	4	4	4	4	4	4	4	4	4	4	4	4	4
26	58528	Nut	2	2	2	2	2	2	2	2	2	2	2	2	2	2	2
27	54951	Bolt	2	2	2	2	2	2	2	2	2	2	2	2	2	2	2
28	233837	Seal	1	1	1	1	1	1	1	1	1	1	1	1	1	1	1

6 BB 162

TIER II

ACCELERATOR PEDAL ASSEMBLY, 100 IN. CABS ONLY

M30-2T	M30-4T	M30-2T H	M30-4T H
M40-2T	M40-4T	M40-2T H	M40-4T H
M50-2T	M50-4T	M50-2T H	M50-4T H
M30-2T L	M30-4T L	M30-2T H L	M30-4T H L
M40-2T L	M40-4T L	M40-2T H L	M40-4T H L
M50-2T L	M50-4T L	M50-2T H L	M50-4T H L

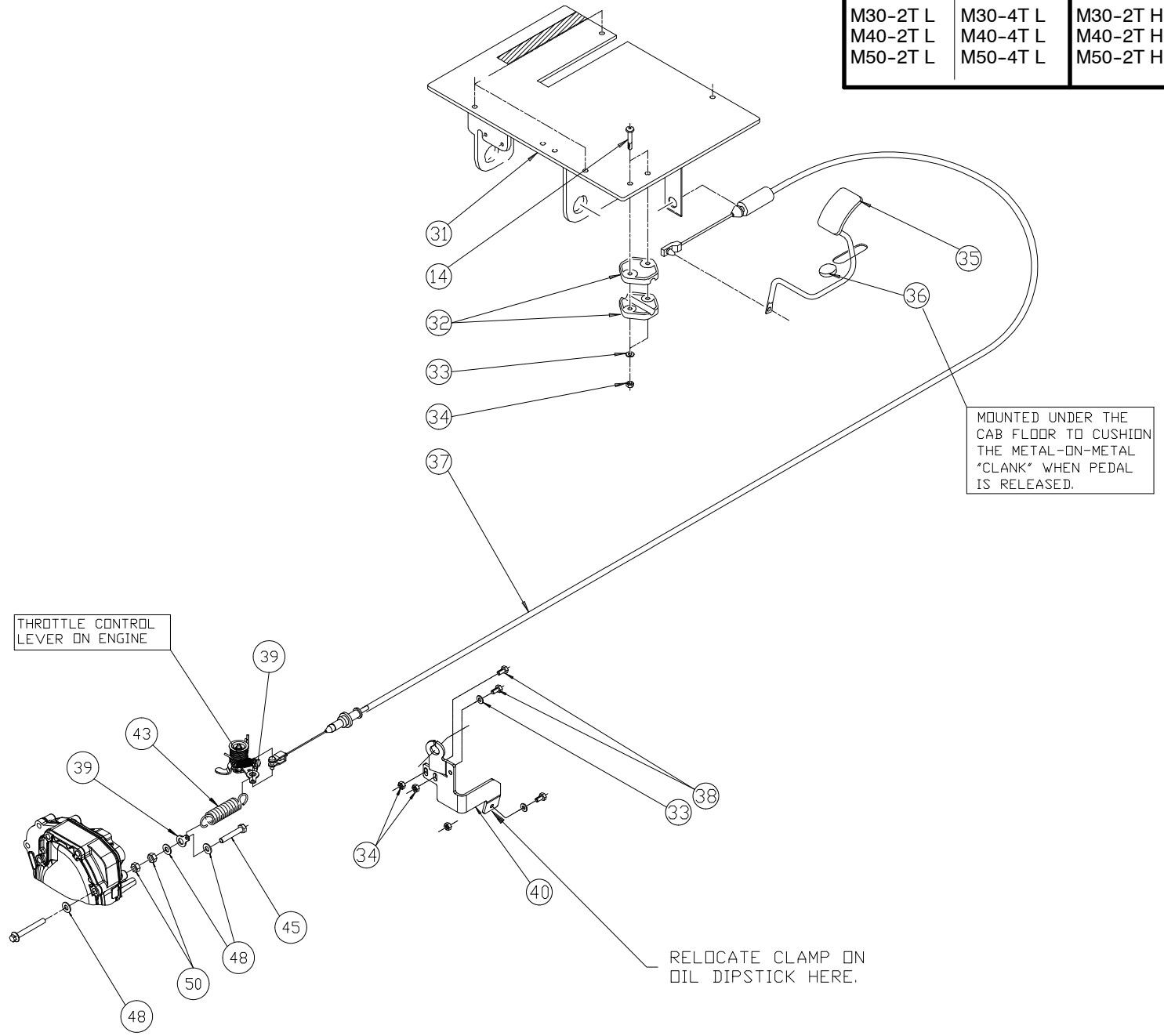

1	ACCELERATOR PEDAL ASSEMBLY, 100 IN. CABS ONLY		QUANTITY / MODEL												6 BB 162		
			M30-4T	M40-4T	M50-4T		M30-4T H	M40-4T H	M50-4T H		M30-4T L	M40-4T L	M50-4T L		M30-4T HL	M40-4T HL	M50-4T HL
ITEM	PART NO.	DESCRIPTION	M30-2T	M40-2T	M50-2T		M30-2T H	M40-2T H	M50-2T H		M30-2T L	M40-2T L	M50-2T L		M30-2T HL	M40-2T HL	M50-2T HL
14	190807	Bolt	2	2	2	2	2	2	2	2	2	2	2	2	2	2	2
32	77957	Clamp, bushing half	2	2	2	2	2	2	2	2	2	2	2	2	2	2	2
33	29469	Washer	3	3	3	3	3	3	3	3	3	3	3	3	3	3	3
34	162229	Nut	4	4	4	4	4	4	4	4	4	4	4	4	4	4	4
35	218013	Accelerator pedal	1	1	1	1	1	1	1	1	1	1	1	1	1	1	1
36	184130	Rubber arrestor	1	1	1	1	1	1	1	1	1	1	1	1	1	1	1
37	806748	Accelerator cable	1	1	1	1	1	1	1	1	1	1	1	1	1	1	1
38	46668	Screw	2	2	2	2	2	2	2	2	2	2	2	2	2	2	2
39	204069	Plate, clip	2	2	2	2	2	2	2	2	2	2	2	2	2	2	2
40	271456	Accelerator cable bracket	1	1	1	1	1	1	1	1	1	1	1	1	1	1	1
43	475379	Spring	1	1	1	1	1	1	1	1	1	1	1	1	1	1	1
45	6224	Bolt	1	1	1	1	1	1	1	1	1	1	1	1	1	1	1
48	61674	Washer	3	3	3	3	3	3	3	3	3	3	3	3	3	3	3
50	58528	Nut	2	2	2	2	2	2	2	2	2	2	2	2	2	2	2

6 BB 163
TIER III

ACCELERATOR PEDAL ASSEMBLY, 77 & 81 IN. CAB

M30-2T	M30-4T	M30-2T H	M30-4T H
M40-2T	M40-4T	M40-2T H	M40-4T H
M50-2T	M50-4T	M50-2T H	M50-4T H
M30-2T L	M30-4T L	M30-2T H L	M30-4T H L
M40-2T L	M40-4T L	M40-2T H L	M40-4T H L
M50-2T L	M50-4T L	M50-2T H L	M50-4T H L

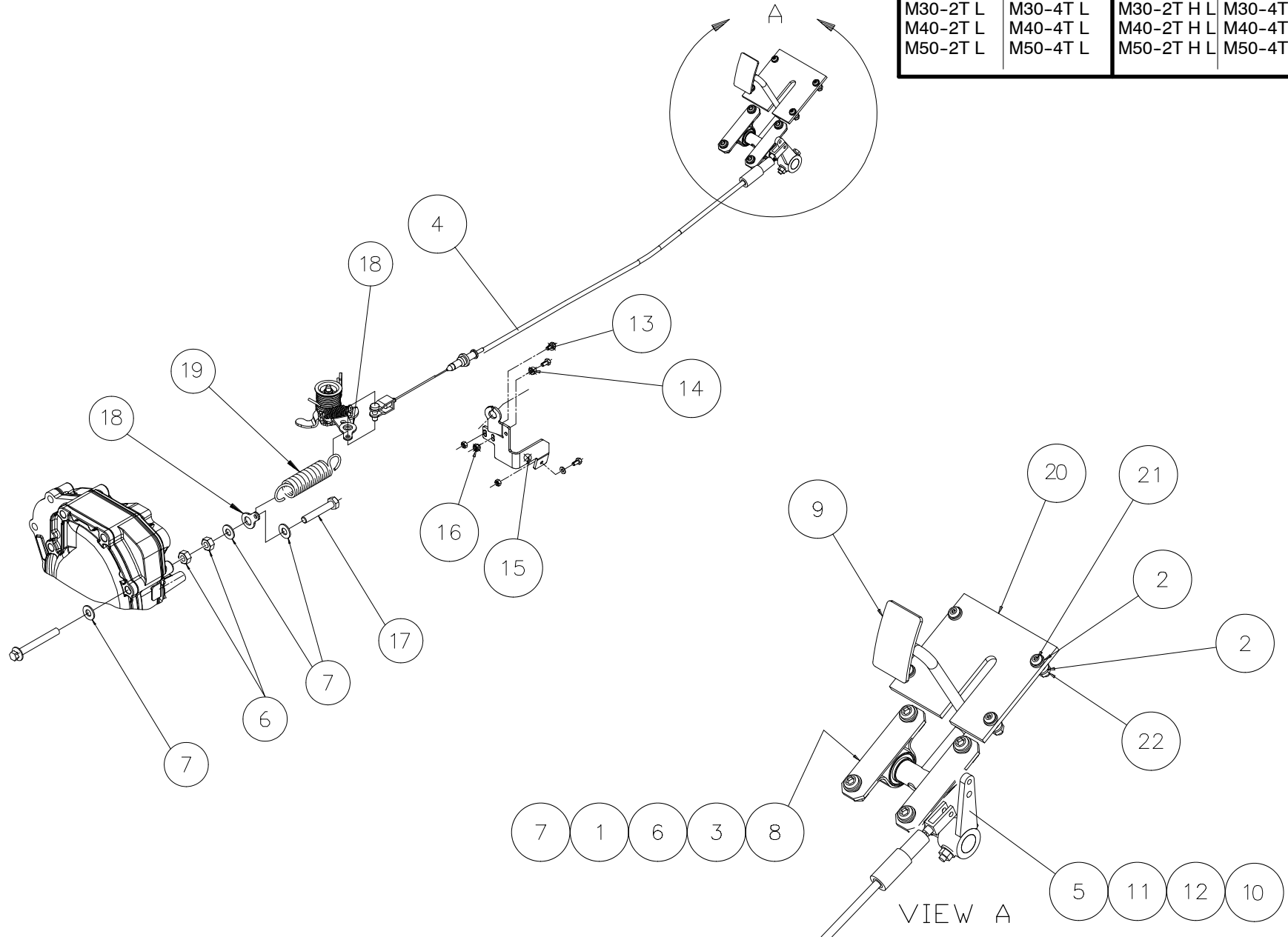

1	ACCELERATOR PEDAL ASSEMBLY, 77 & 81 IN. CAB												6 BB 163					
	ITEM	PART NO.	DESCRIPTION	M30-4T	M40-4T	M50-4T		M30-4T H	M40-4T H	M50-4T H		M30-4T L	M40-4T L	M50-4T L		M30-4T HL	M40-4T HL	M50-4T HL
				M30-2T	M40-2T	M50-2T		M30-2T H	M40-2T H	M50-2T H		M30-2T L	M40-2T L	M50-2T L		M30-2T HL	M40-2T HL	M50-2T HL
1	202144	Screw	4	4	4	4	4	4	4	4	4	4	4	4	4	4	4	4
2	42316	Washer	4	4	4	4	4	4	4	4	4	4	4	4	4	4	4	4
3	42325	Washer	4	4	4	4	4	4	4	4	4	4	4	4	4	4	4	4
4	806748	Cable, accelerator	1	1	1	1	1	1	1	1	1	1	1	1	1	1	1	1
5	493789	Nut	5	5	5	5	5	5	5	5	5	5	5	5	5	5	5	5
6	58528	Nut	4	4	4	4	4	4	4	4	4	4	4	4	4	4	4	4
7	61674	Washer	4	4	4	4	4	4	4	4	4	4	4	4	4	4	4	4
8	801864	Bearing	2	2	2	2	2	2	2	2	2	2	2	2	2	2	2	2
9	804222	Pedal	1	1	1	1	1	1	1	1	1	1	1	1	1	1	1	1
10	806869	Arm	1	1	1	1	1	1	1	1	1	1	1	1	1	1	1	1
11	K300858	Bolt	1	1	1	1	1	1	1	1	1	1	1	1	1	1	1	1
12	K44719	Washer	2	2	2	2	2	2	2	2	2	2	2	2	2	2	2	2
13	46668	Bolt	3	3	3	3	3	3	3	3	3	3	3	3	3	3	3	3
14	29469	Washer	3	3	3	3	3	3	3	3	3	3	3	3	3	3	3	3
15	271456	Bracket	1	1	1	1	1	1	1	1	1	1	1	1	1	1	1	1
16	162229	Nut, lock	3	3	3	3	3	3	3	3	3	3	3	3	3	3	3	3
17	6224	Bolt	1	1	1	1	1	1	1	1	1	1	1	1	1	1	1	1
18	204069	Clip, spring	2	2	2	2	2	2	2	2	2	2	2	2	2	2	2	2
19	475379	Spring	1	1	1	1	1	1	1	1	1	1	1	1	1	1	1	1
20	804806	Cover	1	1	1	1	1	1	1	1	1	1	1	1	1	1	1	1
21	205275	Screw	4	4	4	4	4	4	4	4	4	4	4	4	4	4	4	4
22	25714	Nut	1	1	1	1	1	1	1	1	1	1	1	1	1	1	1	1

7 AA 62
TIER III

STEER AXLE, 2WD

M30-2T	M30-2T H
M40-2T	M40-2T H
M50-2T	M50-2T H
M30-2T L	M30-2T H L
M40-2T L	M40-2T H L
M50-2T L	M50-2T H L

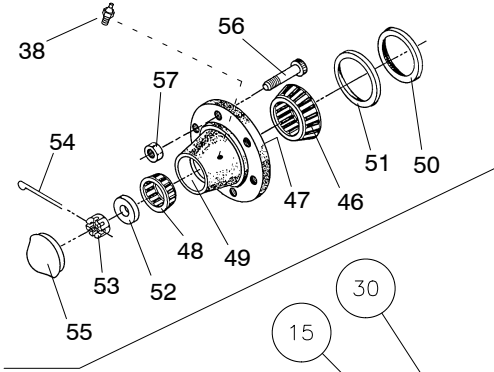

HUB ASSEMBLY
ITEM 45

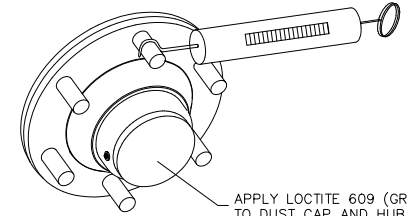

NOTE:

1. PRESET BEARINGS WITH 190 TO 200 FT-LB.
2. FINAL TORQUE AROUND 35-40 FT-LB.
3. FINAL INSPECTION HAS A PULL TEST OF 15-20 LB.

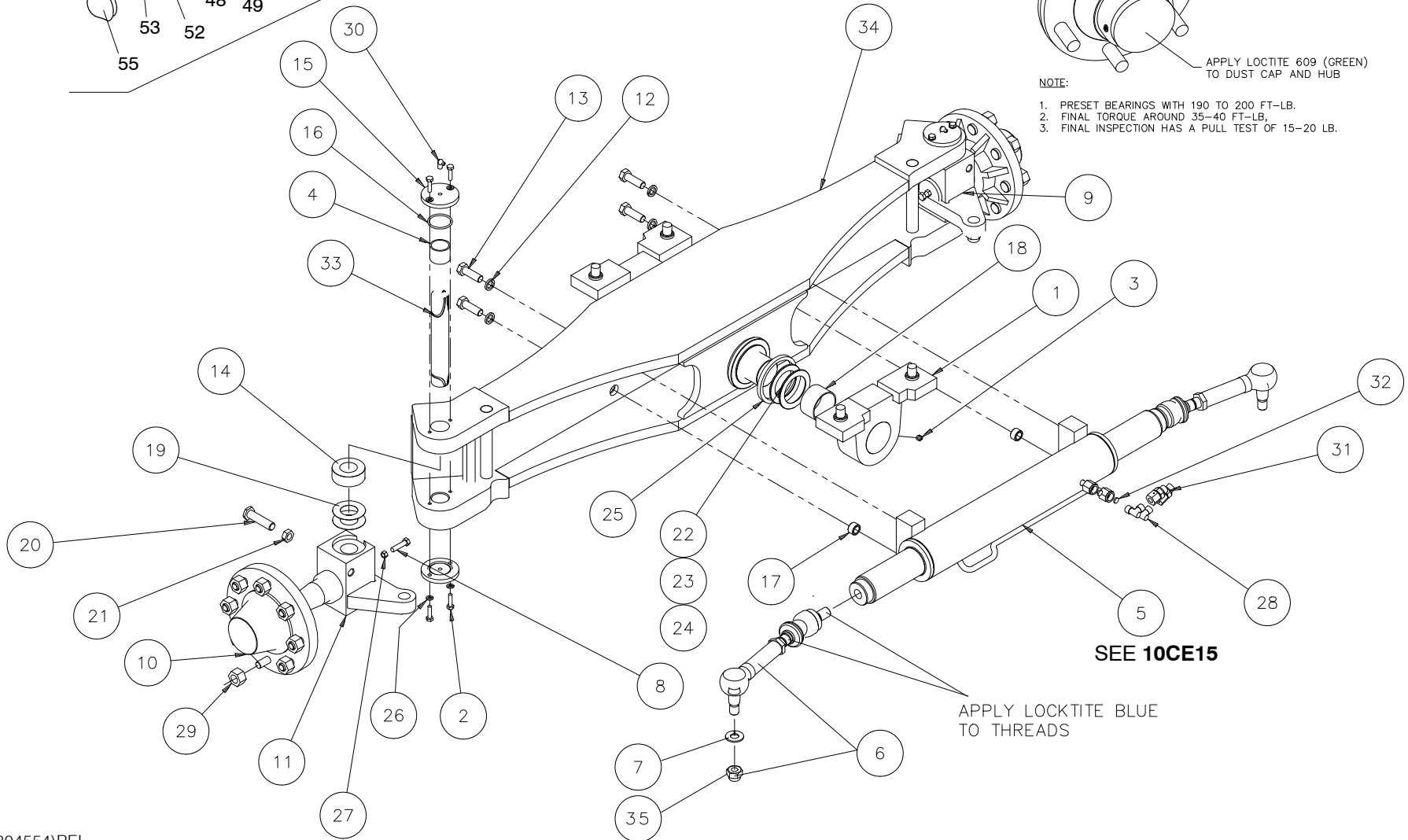

APPLY LOCKTITE BLUE
TO THREADS

1	STEER AXLE, 2WD											7 AA 62											
	ITEM	PART NO.	DESCRIPTION	M30-2T	M40-2T	M50-2T	M30-2T H	M40-2T H	M50-2T H	M30-2T L	M40-2T L	M50-2T L	M30-2T HL	M40-2T HL	M50-2T HL								
1	804554	Steer axle assembly, complete	1	1	1	1	1	1	1	1	1	1	1	1	1								
	206698	Bushing housing	2	2	2	2	2	2	2	2	2	2	2	2	2								
2	63754	Bolt	8	8	8	8	8	8	8	8	8	8	8	8	8								
3	T51534	Grease fitting	2	2	2	2	2	2	2	2	2	2	2	2	2								
4	426041	Bushing	4	4	4	4	4	4	4	4	4	4	4	4	4								
5	200316	Steering cylinder assembly	1	1	1	1	1	1	1	1	1	1	1	1	1								
6	229433	Rod assembly coupling	2	2	2	2	2	2	2	2	2	2	2	2	2								
7	61683	Washer, flat	2	2	2	2	2	2	2	2	2	2	2	2	2								
8	K302264	Screw	2	2	2	2	2	2	2	2	2	2	2	2	2								
9	803920	Spindle arm, LH	1	1	1	1	1	1	1	1	1	1	1	1	1								
10	421318	Hub assembly	2	2	2	2	2	2	2	2	2	2	2	2	2								
11	803922	Spindle arm, RH	1	1	1	1	1	1	1	1	1	1	1	1	1								
12	42322	Washer, lock	4	4	4	4	4	4	4	4	4	4	4	4	4								
13	61308	Bolt	4	4	4	4	4	4	4	4	4	4	4	4	4								
14	421520	Bearing, thrust	2	2	2	2	2	2	2	2	2	2	2	2	2								
15	425674	Cover, king pin	4	4	4	4	4	4	4	4	4	4	4	4	4								
16	K134	O-ring	4	4	4	4	4	4	4	4	4	4	4	4	4								
17	200317	Centering bushing	2	2	2	2	2	2	2	2	2	2	2	2	2								
18	203515	Bushing	2	2	2	2	2	2	2	2	2	2	2	2	2								
19	426131	Shim	A/R	A/R	A/R	A/R	A/R	A/R	A/R	A/R	A/R	A/R	A/R	A/R	A/R								
20	203524	Stop bolt	2	2	2	2	2	2	2	2	2	2	2	2	2								
21	58574	Nut	2	2	2	2	2	2	2	2	2	2	2	2	2								
22	203516	Washer, spacer (3mm - .118 in.)	A/R	A/R	A/R	A/R	A/R	A/R	A/R	A/R	A/R	A/R	A/R	A/R	A/R								
23	203517	Washer, spacer (3.5mm - .138 in.)	A/R	A/R	A/R	A/R	A/R	A/R	A/R	A/R	A/R	A/R	A/R	A/R	A/R								
24	203518	Washer, spacer (4mm - .157 in.)	A/R	A/R	A/R	A/R	A/R	A/R	A/R	A/R	A/R	A/R	A/R	A/R	A/R								

7 AA 64
TIER III

STEERING AXLE AND HANGER INSTALLATION, 2WD

M30-2T M40-2T M50-2T		M30-2T H M40-2T H M50-2T H
M30-2T L M40-2T L M50-2T L		M30-2T H L M40-2T H L M50-2T H L

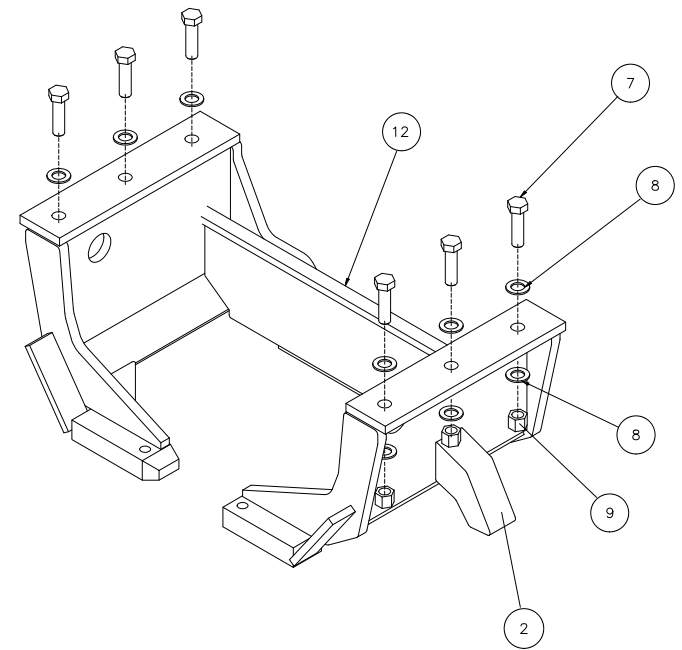
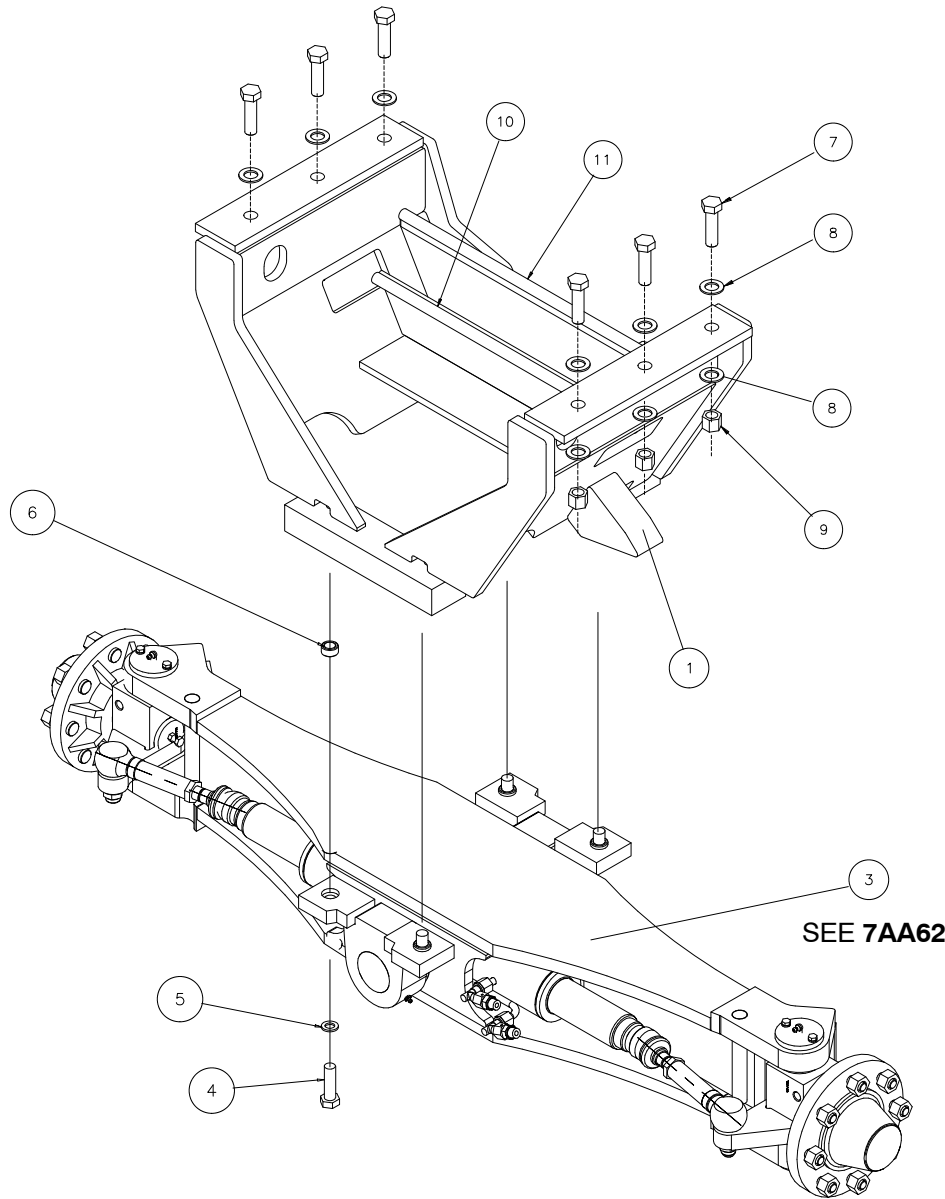

NOTE:
APPLY LOCTITE 242 (BLUE) TO THE THREADS
OF ALL BOLTS DURING INSTALLATION.

807834)REL
807837)REL
804554)B

			QUANTITY / MODEL									7 AA 64					
1	STEERING AXLE AND HANGER INSTALLATION, 2WD																
ITEM	PART NO.	DESCRIPTION	M30-2T	M40-2T	M50-2T		M30-2T H	M40-2T H	M50-2T H		M30-2T L	M40-2T L	M50-2T L		M30-2T HL	M40-2T HL	M50-2T HL
1	807831	Axle hanger, 81" and 100" cab	1	1	1	1	1	1	1	1	1	1	1	1	1	1	1
2	807836	Axle hanger, 77" cab	1	1	1	1	1	1	1	1	1	1	1	1	1	1	1
3	804554	Steer axle	1	1	1	1	1	1	1	1	1	1	1	1	1	1	1
4	448930	Bolt	4	4	4	4	4	4	4	4	4	4	4	4	4	4	4
5	61683	Washer	4	4	4	4	4	4	4	4	4	4	4	4	4	4	4
6	246073	Bushing, centering	4	4	4	4	4	4	4	4	4	4	4	4	4	4	4
7	426688	Bolt	6	6	6	6	6	6	6	6	6	6	6	6	6	6	6
8	426650	Washer	12	12	12	12	12	12	12	12	12	12	12	12	12	12	12
9	R32	Nut	6	6	6	6	6	6	6	6	6	6	6	6	6	6	6
10	Z4117	Seal, 23 inches	1	1	1	1	1	1	1	1	1	1	1	1	1	1	1
11	Z4054	Seal, 25 inches	1	1	1	1	1	1	1	1	1	1	1	1	1	1	1
12	Z4054	Seal, 26 inches	1	1	1	1	1	1	1	1	1	1	1	1	1	1	1

7 AB 14
TIER III

STEERING AXLE AND DRIVESHAFT INSTALLATION, 4WD

M30-4T
M40-4T
M50-4T

M30-4T H
M40-4T H
M50-4T H

M30-4T L
M40-4T L
M50-4T L

M30-4T H L
M40-4T H L
M50-4T H L

NOTE:
APPLY LOCTITE 242 (BLUE)
TO THE THREADS
OF ALL BOLTS DURING INSTALLATION.

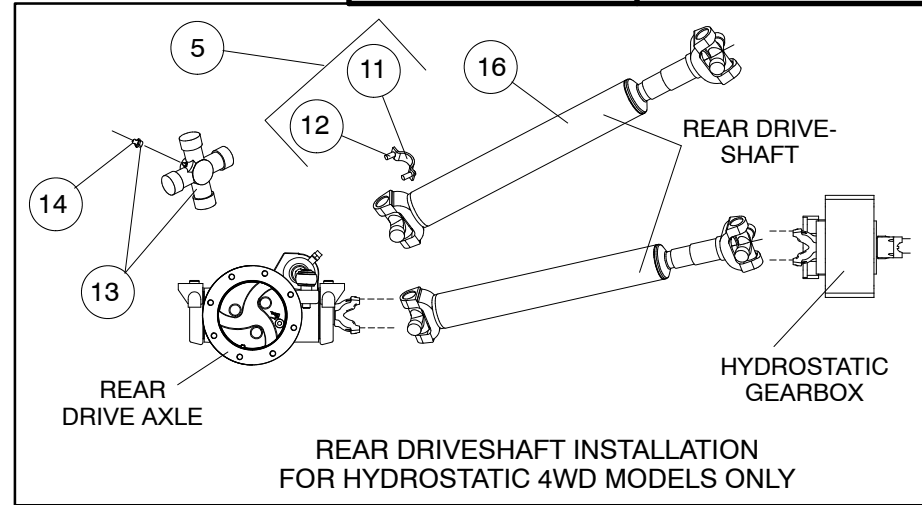
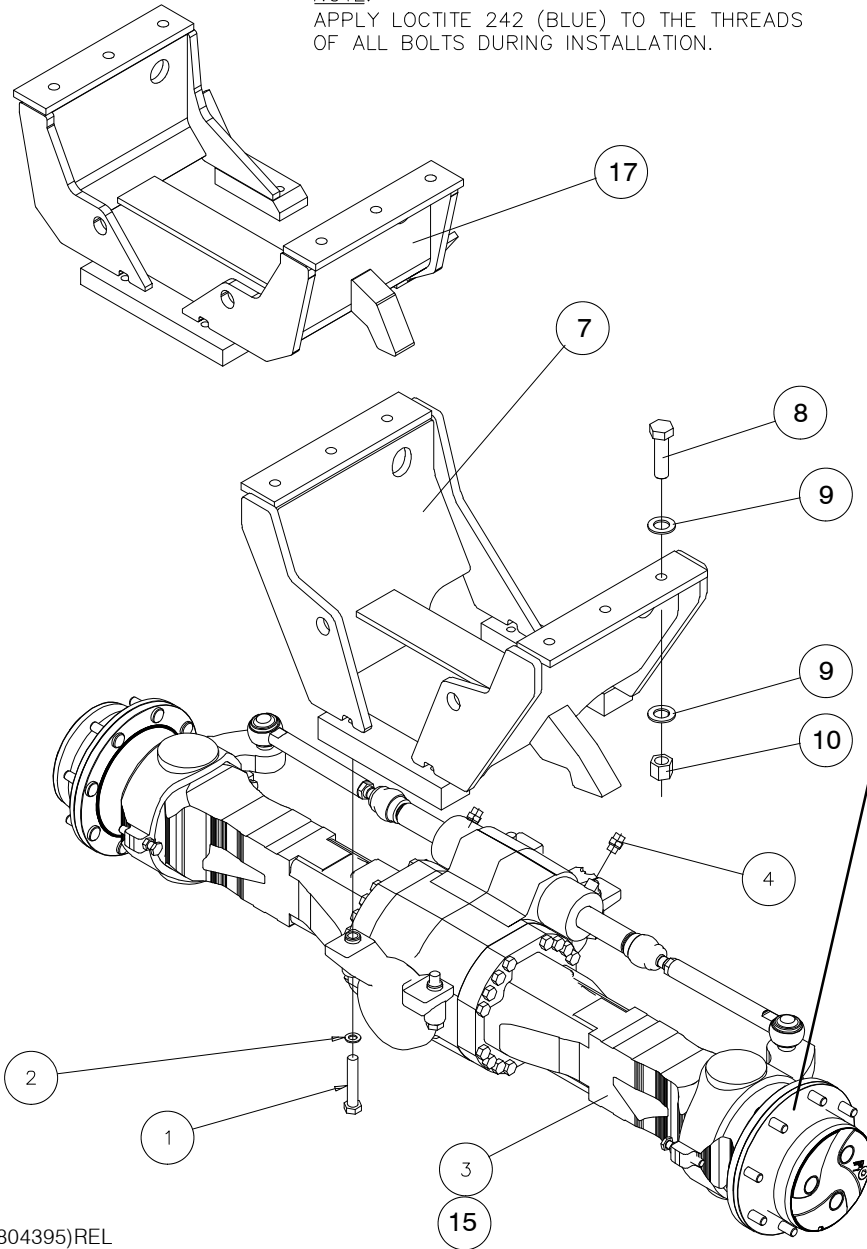

SEE AX2551 FOR 4WD TORQUE CONVERTER MODELS
SEE AX1854 FOR 4WD HYDRASTATIC MODELS

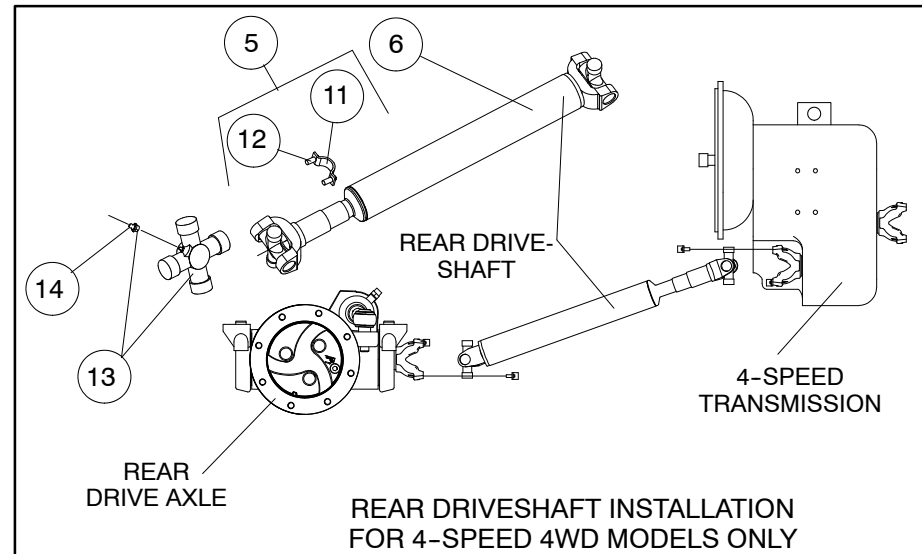

1	STEERING AXLE AND DRIVESHAFT INSTALLATION, 4WD		QUANTITY / MODEL												7 AB 14				
			M30-4T	M40-4T	M50-4T		M30-4T H	M40-4T H	M50-4T H		M30-4T L	M40-4T L	M50-4T L		M30-4T HL	M40-4T HL	M50-4T HL		
ITEM	PART NO.	DESCRIPTION																	
1	58633	Bolt	4	4	4	4	4	4	4	4	4	4	4	4	4	4	4	4	4
2	61683	Washer, flat	4	4	4	4	4	4	4	4	4	4	4	4	4	4	4	4	4
3	247289	Steer axle assembly (4-SPEED MODELS ONLY)	1	1	1	1						1	1	1	1				
4	803282	Connector	2	2	2	2	2	2	2	2	2	2	2	2	2	2	2	2	2
5	425330	Strap and bolt kit	2	2	2	2	2	2	2	2	2	2	2	2	2	2	2	2	2
6	802048	Drive shaft, rear (4-SPEED MODELS ONLY)	1	1	1	1						1	1	1	1				
7	807831	Axle hanger, (100 & 81 IN. CAB ONLY)	1	1	1	1	1	1	1	1	1	1	1	1	1	1	1	1	1
8	426688	Bolt	6	6	6	6	6	6	6	6	6	6	6	6	6	6	6	6	6
9	426650	Washer, flat	12	12	12	12	12	12	12	12	12	12	12	12	12	12	12	12	12
10	R32	Nut	6	6	6	6	6	6	6	6	6	6	6	6	6	6	6	6	6
11	109751	Strap	A/R	A/R	A/R	A/R	A/R	A/R	A/R	A/R	A/R	A/R	A/R	A/R	A/R	A/R	A/R	A/R	A/R
12	109752	Bolt	A/R	A/R	A/R	A/R	A/R	A/R	A/R	A/R	A/R	A/R	A/R	A/R	A/R	A/R	A/R	A/R	A/R
13	424647	U-joint	A/R	A/R	A/R	A/R	A/R	A/R	A/R	A/R	A/R	A/R	A/R	A/R	A/R	A/R	A/R	A/R	A/R
14	162809	Zerk, grease fitting	A/R	A/R	A/R	A/R	A/R	A/R	A/R	A/R	A/R	A/R	A/R	A/R	A/R	A/R	A/R	A/R	A/R
15	804064	Steer axle assembly (HYDROSTATIC MODELS ONLY)					1	1	1	1						1	1	1	1
16	802049	Drive shaft, rear (HYDROSTATIC MODELS ONLY)					1	1	1	1						1	1	1	1
17	807836	Axle hanger, (77 IN. CAB ONLY)	1	1	1	1	1	1	1	1	1	1	1	1	1	1	1	1	1

8 AA 462
TIER III

CAB ASSEMBLY, 100 IN. FULLY ENCLOSED

M30-2T	M30-4T	M30-2T H	M30-4T H
M40-2T	M40-4T	M40-2T H	M40-4T H
M50-2T	M50-4T	M50-2T H	M50-4T H
M30-2T L	M30-4T L	M30-2T H L	M30-4T H L
M40-2T L	M40-4T L	M40-2T H L	M40-4T H L
M50-2T L	M50-4T L	M50-2T H L	M50-4T H L

CAB ASSEMBLY INCLUDES WIRING FOR CAB OPTIONS (BEACON, WORK LIGHTS, ETC.)

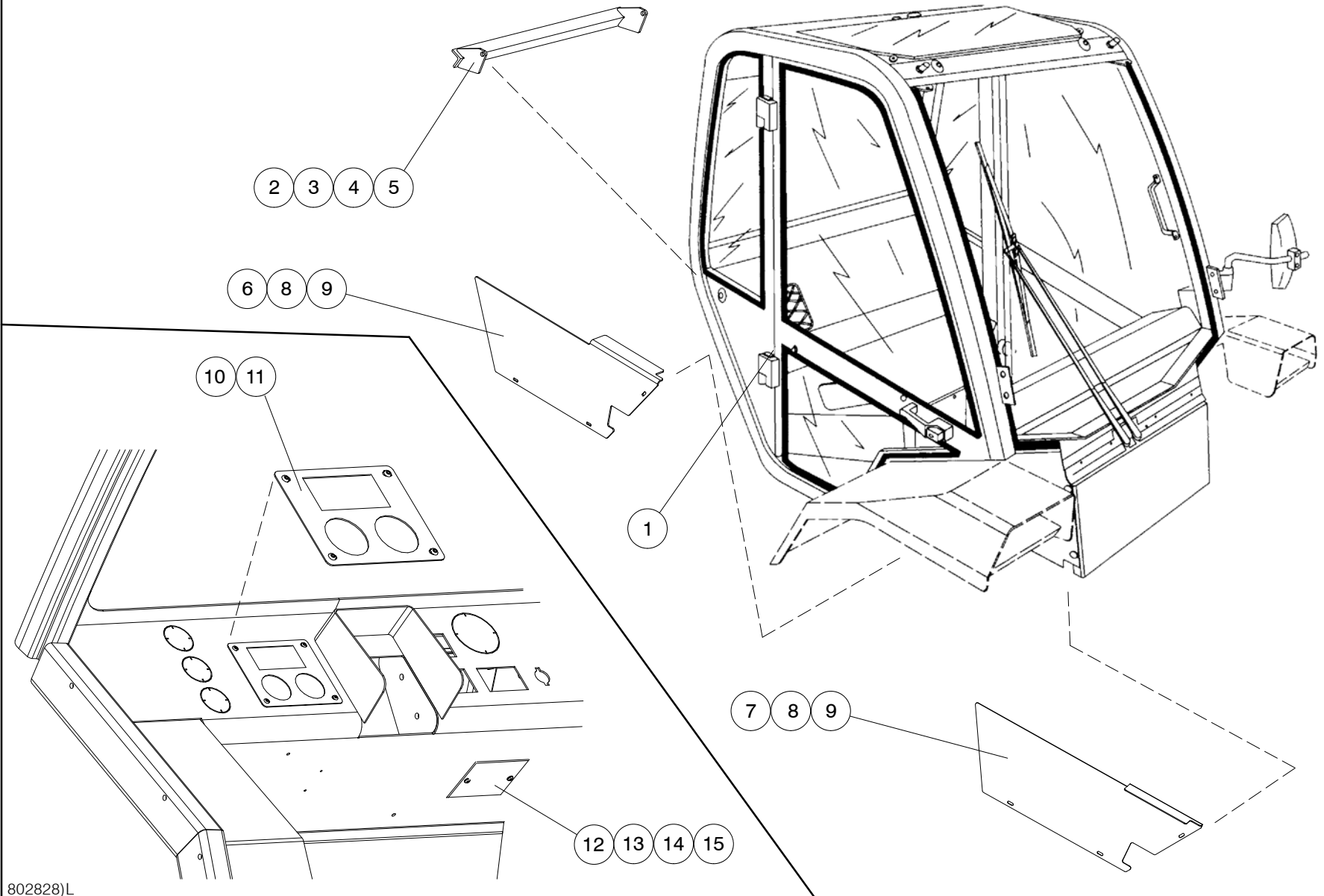

1	CAB ASSEMBLY, 100 IN. FULLY ENCLOSED		QUANTITY / MODEL											8 AA 462			
			M30-4T	M40-4T	M50-4T		M30-4T H	M40-4T H	M50-4T H		M30-4T L	M40-4T L	M50-4T L		M30-4T HL	M40-4T HL	M50-4T HL
ITEM	PART NO.	DESCRIPTION	M30-2T	M40-2T	M50-2T		M30-2T H	M40-2T H	M50-2T H		M30-2T L	M40-2T L	M50-2T L		M30-2T HL	M40-2T HL	M50-2T HL
1	804783	Cab assembly, fully enclosed (DOES NOT include the front fenders or Items 2 thru 15)	1	1	1	1	1	1	1	1	1	1	1	1	1	1	1
2	802658	Cab support angle	1	1	1	1	1	1	1	1	1	1	1	1	1	1	1
3	29437	Washer, flat	4	4	4	4	4	4	4	4	4	4	4	4	4	4	4
4	56354	Nut	2	2	2	2	2	2	2	2	2	2	2	2	2	2	2
5	168351	Bolt	2	2	2	2	2	2	2	2	2	2	2	2	2	2	2
6	804782	Cover, cab RH	1	1	1	1	1	1	1	1	1	1	1	1	1	1	1
7	804781	Cover, cab LH	1	1	1	1	1	1	1	1	1	1	1	1	1	1	1
8	25713	Bolt	6	6	6	6	6	6	6	6	6	6	6	6	6	6	6
9	42316	Washer, lock	6	6	6	6	6	6	6	6	6	6	6	6	6	6	6
10	802755	Plate, gauge	1	1	1	1	1	1	1	1	1	1	1	1	1	1	1
11	79533	Screw	4	4	4	4	4	4	4	4	4	4	4	4	4	4	4
12	804303	Plate, cover	1	1	1	1	1	1	1	1	1	1	1	1	1	1	1
13	28959	Washer	4	4	4	4	4	4	4	4	4	4	4	4	4	4	4
14	54232	Nut	2	2	2	2	2	2	2	2	2	2	2	2	2	2	2
15	184036	Screw	2	2	2	2	2	2	2	2	2	2	2	2	2	2	2

8 AA 463

TIER III

CAB DETAILS 1, 100 IN. FULLY ENCLOSED

M30-2T	M30-4T	M30-2T H	M30-4T H
M40-2T	M40-4T	M40-2T H	M40-4T H
M50-2T	M50-4T	M50-2T H	M50-4T H
M30-2T L	M30-4T L	M30-2T H L	M30-4T H L
M40-2T L	M40-4T L	M40-2T H L	M40-4T H L
M50-2T L	M50-4T L	M50-2T H L	M50-4T H L

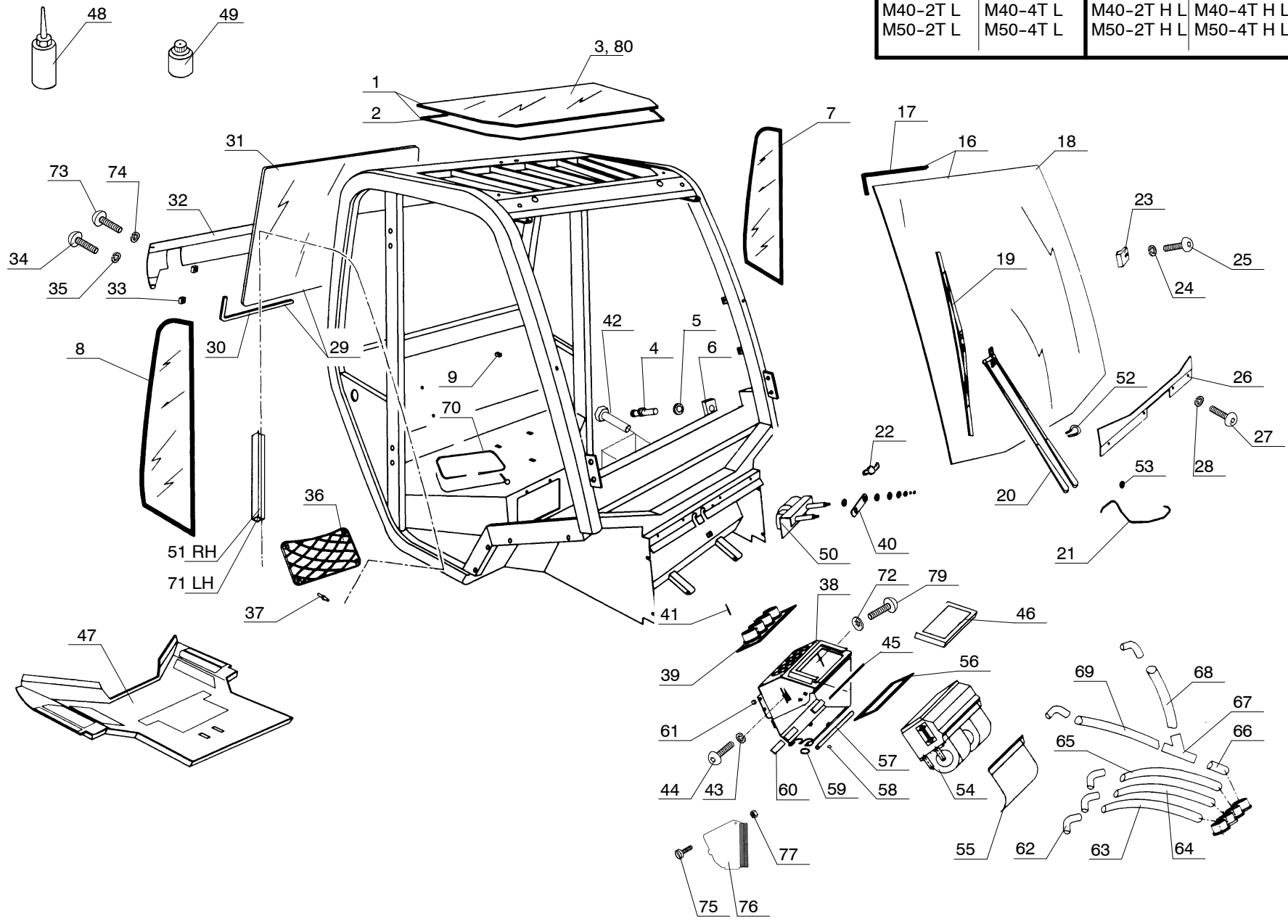

1	CAB DETAILS 1, 100 IN. FULLY ENCLOSED		QUANTITY / MODEL												8 AA 463		
			M30-4T	M40-4T	M50-4T		M30-4T H	M40-4T H	M50-4T H		M30-4T L	M40-4T L	M50-4T L		M30-4T HL	M40-4T HL	M50-4T HL
ITEM	PART NO.	DESCRIPTION	M30-2T	M40-2T	M50-2T		M30-2T H	M40-2T H	M50-2T H		M30-2T L	M40-2T L	M50-2T L		M30-2T HL	M40-2T HL	M50-2T HL
1	552426	Weatherstrip	1	1	1	1	1	1	1	1	1	1	1	1	1	1	1
2	182038	Seal	1	1	1	1	1	1	1	1	1	1	1	1	1	1	1
3	206271	Roof glass	1	1	1	1	1	1	1	1	1	1	1	1	1	1	1
4	182179	Fastener	2	2	2	2	2	2	2	2	2	2	2	2	2	2	2
5	182180	Washer	2	2	2	2	2	2	2	2	2	2	2	2	2	2	2
6	182181	Fastening plate	2	2	2	2	2	2	2	2	2	2	2	2	2	2	2
7	561093	Side glass, LH	1	1	1	1	1	1	1	1	1	1	1	1	1	1	1
8	561092	Side glass, RH	1	1	1	1	1	1	1	1	1	1	1	1	1	1	1
9	551882	Nut	4	4	4	4	4	4	4	4	4	4	4	4	4	4	4
16	561515	Front windshield w/seal	1	1	1	1	1	1	1	1	1	1	1	1	1	1	1
17	189752	Weatherstrip	1	1	1	1	1	1	1	1	1	1	1	1	1	1	1
18	561086	Front windshield	1	1	1	1	1	1	1	1	1	1	1	1	1	1	1
19	198290	Wiper blade	1	1	1	1	1	1	1	1	1	1	1	1	1	1	1
20	561518	Blade holder	1	1	1	1	1	1	1	1	1	1	1	1	1	1	1
21	199956	Hose	1	1	1	1	1	1	1	1	1	1	1	1	1	1	1
22	199955	Connection	1	1	1	1	1	1	1	1	1	1	1	1	1	1	1
23	552670	Fastening lug	2	2	2	2	2	2	2	2	2	2	2	2	2	2	2
24	174132	Washer	2	2	2	2	2	2	2	2	2	2	2	2	2	2	2
25	205275	Screw	2	2	2	2	2	2	2	2	2	2	2	2	2	2	2
26	561519	Fastening plate	1	1	1	1	1	1	1	1	1	1	1	1	1	1	1
27	183396	Screw	4	4	4	4	4	4	4	4	4	4	4	4	4	4	4
28	194673	Washer	4	4	4	4	4	4	4	4	4	4	4	4	4	4	4
29	561520	Weatherstrip	1	1	1	1	1	1	1	1	1	1	1	1	1	1	1
30	182101	Weatherstrip	1	1	1	1	1	1	1	1	1	1	1	1	1	1	1

8 AA 464

TIER III

CAB DETAILS 2, 100 IN. FULLY ENCLOSED

M30-2T	M30-4T	M30-2T H	M30-4T H
M40-2T	M40-4T	M40-2T H	M40-4T H
M50-2T	M50-4T	M50-2T H	M50-4T H
M30-2T L	M30-4T L	M30-2T H L	M30-4T H L
M40-2T L	M40-4T L	M40-2T H L	M40-4T H L
M50-2T L	M50-4T L	M50-2T H L	M50-4T H L

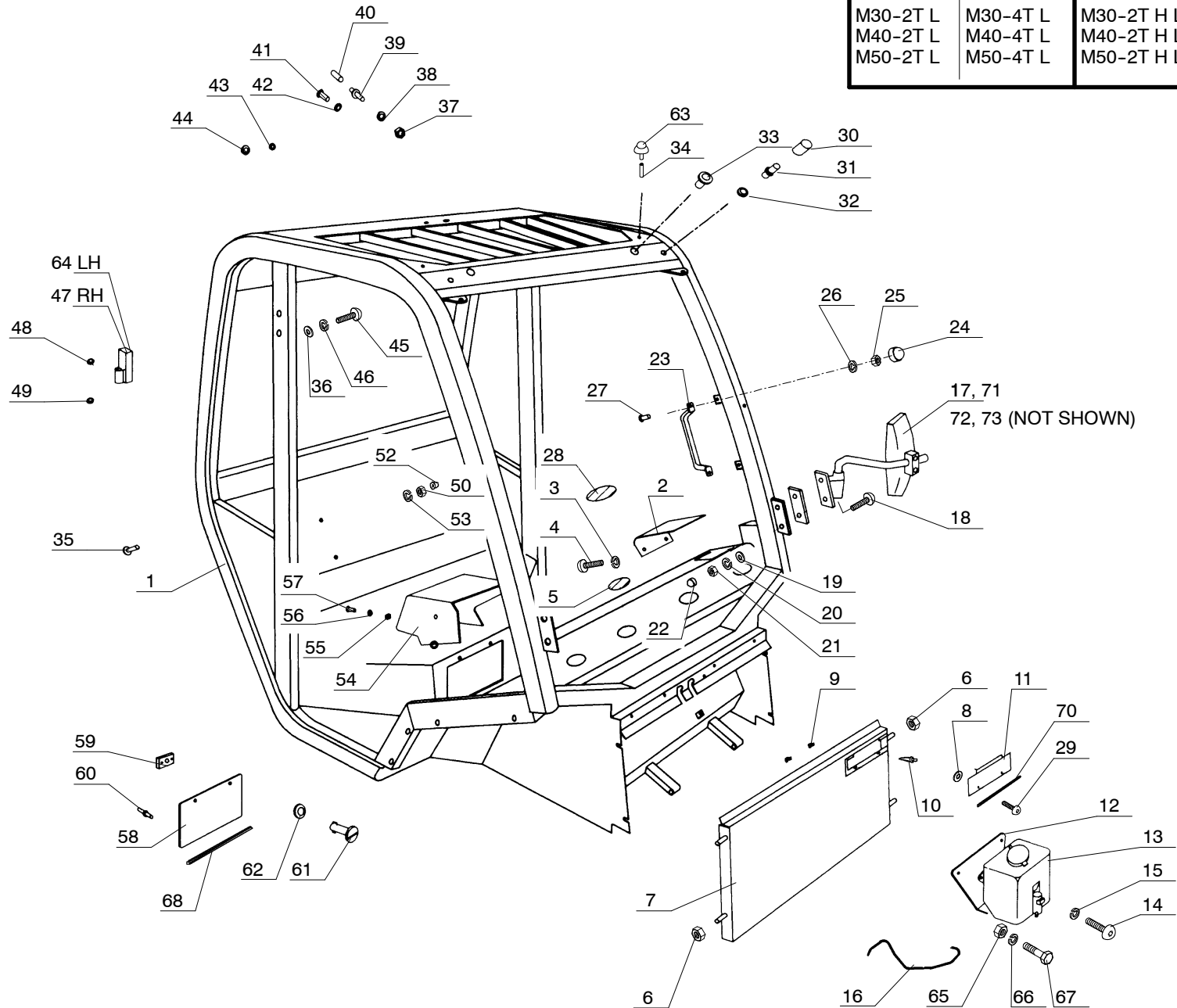

1	CAB DETAILS 2, 100 IN. FULLY ENCLOSED		QUANTITY / MODEL											8 AA 464			
			M30-4T	M40-4T	M50-4T		M30-4T H	M40-4T H	M50-4T H		M30-4T L	M40-4T L	M50-4T L		M30-4T HL	M40-4T HL	M50-4T HL
ITEM	PART NO.	DESCRIPTION	M30-2T	M40-2T	M50-2T		M30-2T H	M40-2T H	M50-2T H		M30-2T L	M40-2T L	M50-2T L		M30-2T HL	M40-2T HL	M50-2T HL
1	603844	Frame work	1	1	1	1	1	1	1	1	1	1	1	1	1	1	1
2	561524	Fastening plate	1	1	1	1	1	1	1	1	1	1	1	1	1	1	1
3	194673	Washer	2	2	2	2	2	2	2	2	2	2	2	2	2	2	2
4	183396	Screw	2	2	2	2	2	2	2	2	2	2	2	2	2	2	2
5	561527	Air nozzle	4	4	4	4	4	4	4	4	4	4	4	4	4	4	4
6	54242	Nut	4	4	4	4	4	4	4	4	4	4	4	4	4	4	4
7	562196	Front fastening plate	1	1	1	1	1	1	1	1	1	1	1	1	1	1	1
8	562197	Washer	2	2	2	2	2	2	2	2	2	2	2	2	2	2	2
9	562198	Locking casing	2	2	2	2	2	2	2	2	2	2	2	2	2	2	2
10	174677	Rivet	4	4	4	4	4	4	4	4	4	4	4	4	4	4	4
11	562199	Fastening plate	1	1	1	1	1	1	1	1	1	1	1	1	1	1	1
12	201008	Bracket	1	1	1	1	1	1	1	1	1	1	1	1	1	1	1
13	190776	Windshield washer tank	1	1	1	1	1	1	1	1	1	1	1	1	1	1	1
14	79533	Screw	2	2	2	2	2	2	2	2	2	2	2	2	2	2	2
15	29483	Washer	2	2	2	2	2	2	2	2	2	2	2	2	2	2	2
16	561526	Hose	1	1	1	1	1	1	1	1	1	1	1	1	1	1	1
17	551451	Rear view mirror, LH	1	1	1	1	1	1	1	1	1	1	1	1	1	1	1
18	29441	Screw	2	2	2	2	2	2	2	2	2	2	2	2	2	2	2
19	29469	Washer	2	2	2	2	2	2	2	2	2	2	2	2	2	2	2
20	42316	Washer	2	2	2	2	2	2	2	2	2	2	2	2	2	2	2
21	25714	Nut	2	2	2	2	2	2	2	2	2	2	2	2	2	2	2
22	55404	Cap	2	2	2	2	2	2	2	2	2	2	2	2	2	2	2
23	195535	Handle	2	2	2	2	2	2	2	2	2	2	2	2	2	2	2
24	55404	Cap	4	4	4	4	4	4	4	4	4	4	4	4	4	4	4
25	25714	Nut	4	4	4	4	4	4	4	4	4	4	4	4	4	4	4
26	29469	Washer	4	4	4	4	4	4	4	4	4	4	4	4	4	4	4
27	46668	Screw	4	4	4	4	4	4	4	4	4	4	4	4	4	4	4

8 AA 465
TIER III

CAB DETAILS 3, 100 IN. FULLY ENCLOSED

M30-2T	M30-4T	M30-2T H	M30-4T H
M40-2T	M40-4T	M40-2T H	M40-4T H
M50-2T	M50-4T	M50-2T H	M50-4T H
M30-2T L	M30-4T L	M30-2T H L	M30-4T H L
M40-2T L	M40-4T L	M40-2T H L	M40-4T H L
M50-2T L	M50-4T L	M50-2T H L	M50-4T H L

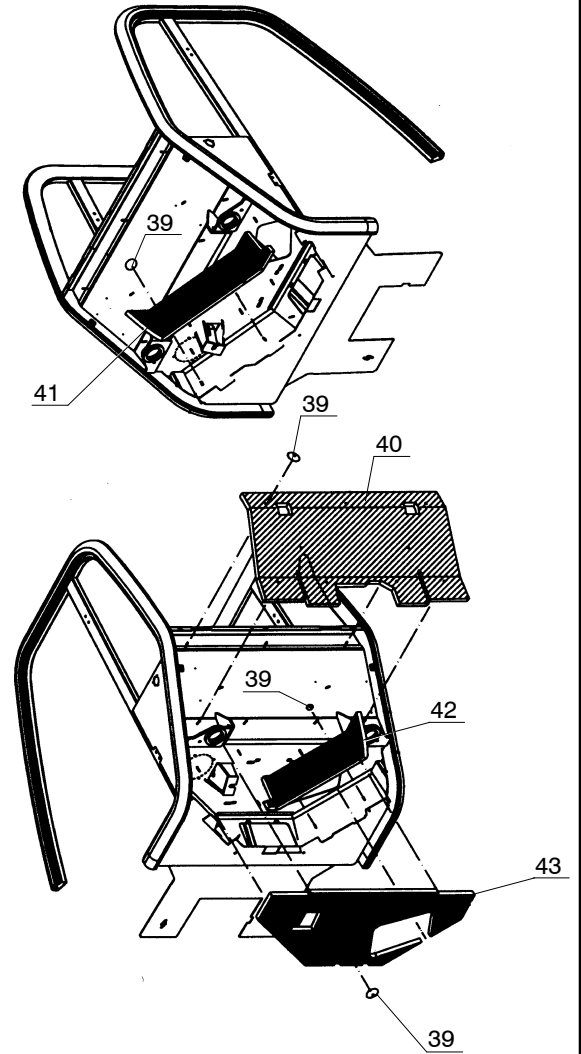
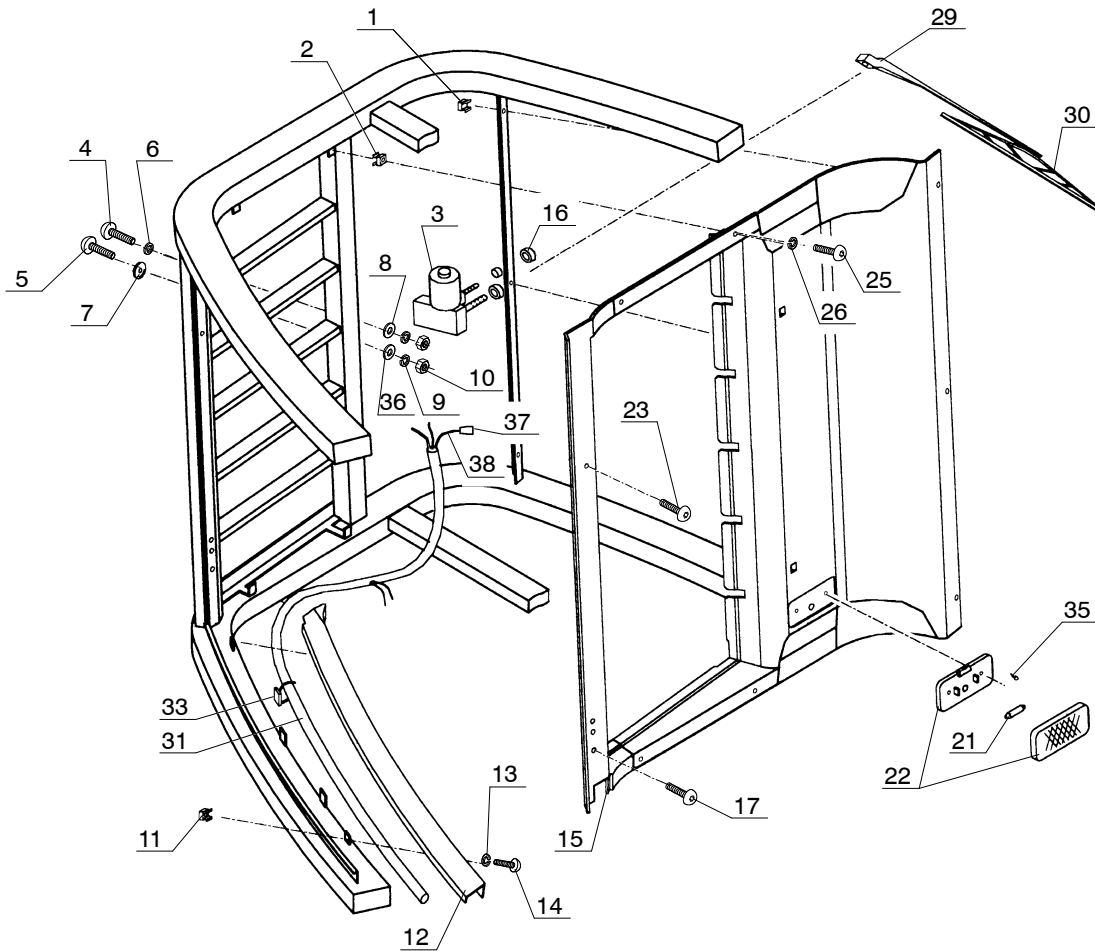

1	CAB DETAILS 3, 100 IN. FULLY ENCLOSED		QUANTITY / MODEL												8 AA 465		
			M30-4T	M40-4T	M50-4T		M30-4T H	M40-4T H	M50-4T H		M30-4T L	M40-4T L	M50-4T L		M30-4T HL	M40-4T HL	M50-4T HL
ITEM	PART NO.	DESCRIPTION	M30-2T	M40-2T	M50-2T		M30-2T H	M40-2T H	M50-2T H		M30-2T L	M40-2T L	M50-2T L		M30-2T HL	M40-2T HL	M50-2T HL
1	551582	Nut	3	3	3	3	3	3	3	3	3	3	3	3	3	3	3
2	551582	Nut	4	4	4	4	4	4	4	4	4	4	4	4	4	4	4
3	552760	Windshield wiper motor	1	1	1	1	1	1	1	1	1	1	1	1	1	1	1
4	202144	Screw	1	1	1	1	1	1	1	1	1	1	1	1	1	1	1
5	42412	Screw	1	1	1	1	1	1	1	1	1	1	1	1	1	1	1
6	194661	Washer	1	1	1	1	1	1	1	1	1	1	1	1	1	1	1
7	551560	Washer	1	1	1	1	1	1	1	1	1	1	1	1	1	1	1
8	61674	Washer	2	2	2	2	2	2	2	2	2	2	2	2	2	2	2
9	42325	Washer	2	2	2	2	2	2	2	2	2	2	2	2	2	2	2
10	58528	Nut	2	2	2	2	2	2	2	2	2	2	2	2	2	2	2
11	551582	Nut	2	2	2	2	2	2	2	2	2	2	2	2	2	2	2
12	561528	Drain trough	1	1	1	1	1	1	1	1	1	1	1	1	1	1	1
13	551600	Washer	2	2	2	2	2	2	2	2	2	2	2	2	2	2	2
14	199976	Screw	2	2	2	2	2	2	2	2	2	2	2	2	2	2	2
15	561529	Roof fitting	1	1	1	1	1	1	1	1	1	1	1	1	1	1	1
16	166702	Cap	1	1	1	1	1	1	1	1	1	1	1	1	1	1	1
17	205275	Screw	2	2	2	2	2	2	2	2	2	2	2	2	2	2	2
21	61799	Bulb	1	1	1	1	1	1	1	1	1	1	1	1	1	1	1
22	54564	Roof lamp	1	1	1	1	1	1	1	1	1	1	1	1	1	1	1
23	194668	Screw	2	2	2	2	2	2	2	2	2	2	2	2	2	2	2
25	199976	Screw	7	7	7	7	7	7	7	7	7	7	7	7	7	7	7
26	551600	Washer	7	7	7	7	7	7	7	7	7	7	7	7	7	7	7
29	184526	Blade holder	1	1	1	1	1	1	1	1	1	1	1	1	1	1	1
30	54557	Brush	1	1	1	1	1	1	1	1	1	1	1	1	1	1	1

8 AA 466

TIER III

CAB DETAILS 4, 100 IN. FULLY ENCLOSED

M30-2T	M30-4T	M30-2T H	M30-4T H
M40-2T	M40-4T	M40-2T H	M40-4T H
M50-2T	M50-4T	M50-2T H	M50-4T H
M30-2T L	M30-4T L	M30-2T H L	M30-4T H L
M40-2T L	M40-4T L	M40-2T H L	M40-4T H L
M50-2T L	M50-4T L	M50-2T H L	M50-4T H L

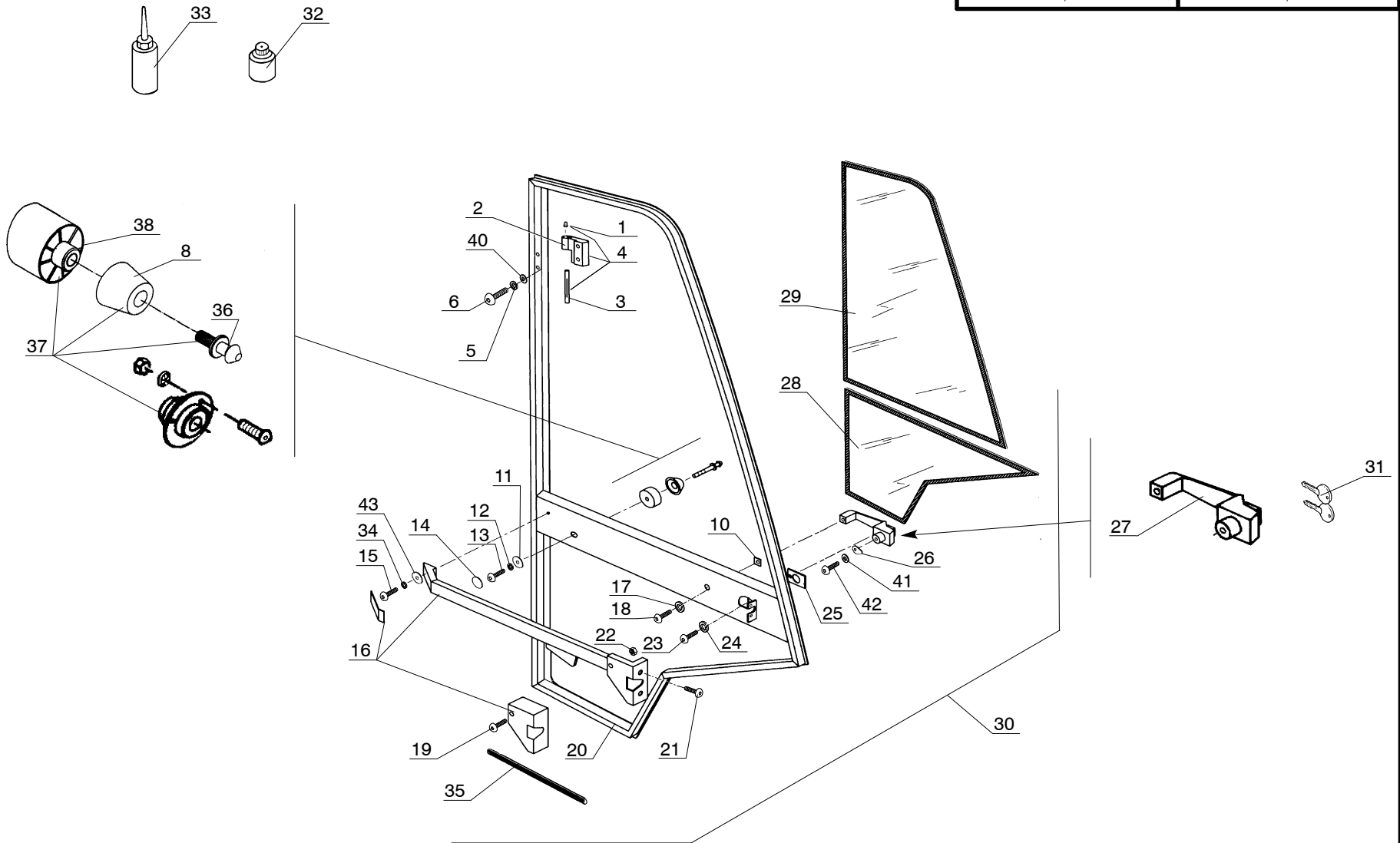

1	CAB DETAILS 4, 100 IN. FULLY ENCLOSED		QUANTITY / MODEL											8 AA 466			
			M30-4T	M40-4T	M50-4T		M30-4T H	M40-4T H	M50-4T H		M30-4T L	M40-4T L	M50-4T L		M30-4T HL	M40-4T HL	M50-4T HL
ITEM	PART NO.	DESCRIPTION	M30-2T	M40-2T	M50-2T		M30-2T H	M40-2T H	M50-2T H		M30-2T L	M40-2T L	M50-2T L		M30-2T HL	M40-2T HL	M50-2T HL
1	199961	Greaser	4	4	4	4	4	4	4	4	4	4	4	4	4	4	4
2	203452	Half hinge, stripped	2	2	2	2	2	2	2	2	2	2	2	2	2	2	2
3	199963	Axle	4	4	4	4	4	4	4	4	4	4	4	4	4	4	4
4	201931	Half hinge (includes Items 1, 2, 3)	2	2	2	2	2	2	2	2	2	2	2	2	2	2	2
5	42325	Washer	8	8	8	8	8	8	8	8	8	8	8	8	8	8	8
6	190734	Screw	8	8	8	8	8	8	8	8	8	8	8	8	8	8	8
8	550649	Door locking	2	2	2	2	2	2	2	2	2	2	2	2	2	2	2
10	564149	Gasket	2	2	2	2	2	2	2	2	2	2	2	2	2	2	2
11	61674	Washer	2	2	2	2	2	2	2	2	2	2	2	2	2	2	2
12	42325	Washer	2	2	2	2	2	2	2	2	2	2	2	2	2	2	2
13	202731	Screw	2	2	2	2	2	2	2	2	2	2	2	2	2	2	2
14	603210	Plug	2	2	2	2	2	2	2	2	2	2	2	2	2	2	2
15	196951	Screw	2	2	2	2	2	2	2	2	2	2	2	2	2	2	2
16	551869	Inner lock, LH	1	1	1	1	1	1	1	1	1	1	1	1	1	1	1
17	174132	Washer	2	2	2	2	2	2	2	2	2	2	2	2	2	2	2
18	183396	Screw	2	2	2	2	2	2	2	2	2	2	2	2	2	2	2
19	199978	Screw	2	2	2	2	2	2	2	2	2	2	2	2	2	2	2
20	600831	Door, stripped, LH	1	1	1	1	1	1	1	1	1	1	1	1	1	1	1
21	199978	Screw	4	4	4	4	4	4	4	4	4	4	4	4	4	4	4
22	162229	Nut	2	2	2	2	2	2	2	2	2	2	2	2	2	2	2
23	183396	Screw	4	4	4	4	4	4	4	4	4	4	4	4	4	4	4
24	174132	Washer	4	4	4	4	4	4	4	4	4	4	4	4	4	4	4
25	564148	Gasket	2	2	2	2	2	2	2	2	2	2	2	2	2	2	2
26	561535	Fastening plate	2	2	2	2	2	2	2	2	2	2	2	2	2	2	2
27	564147	Outer handle	2	2	2	2	2	2	2	2	2	2	2	2	2	2	2
28	561091	Lower door glass, stripped, LH	1	1	1	1	1	1	1	1	1	1	1	1	1	1	1

8 AA 467
TIER III

CAB DETAILS 5, 100 IN. FULLY ENCLOSED

M30-2T	M30-4T	M30-2T H	M30-4T H
M40-2T	M40-4T	M40-2T H	M40-4T H
M50-2T	M50-4T	M50-2T H	M50-4T H
M30-2T L	M30-4T L	M30-2T H L	M30-4T H L
M40-2T L	M40-4T L	M40-2T H L	M40-4T H L
M50-2T L	M50-4T L	M50-2T H L	M50-4T H L

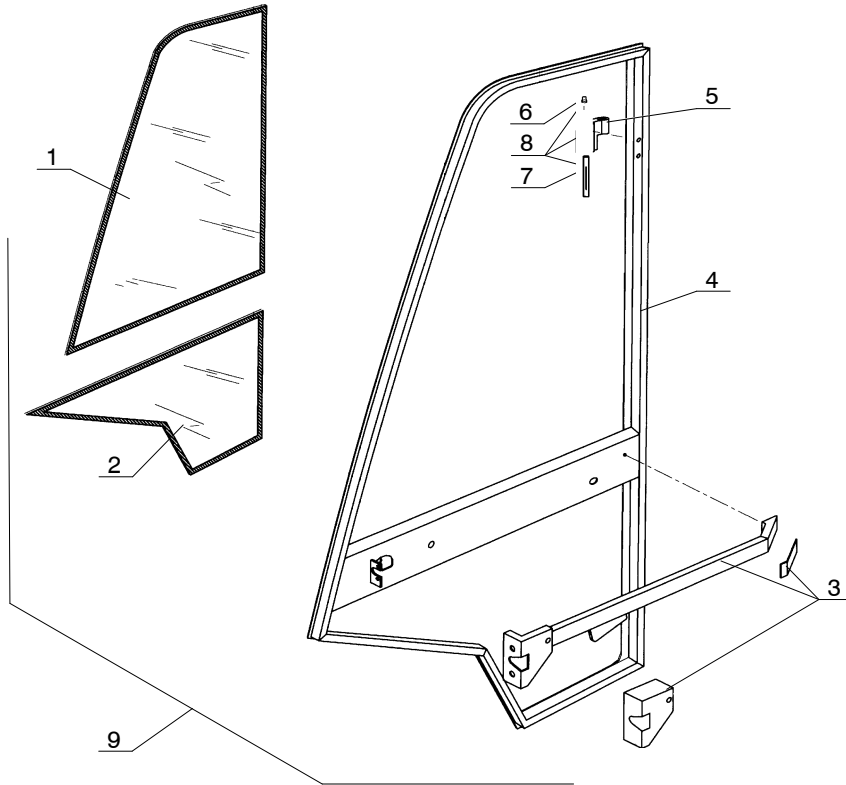

SLIDING WINDOW OPTION

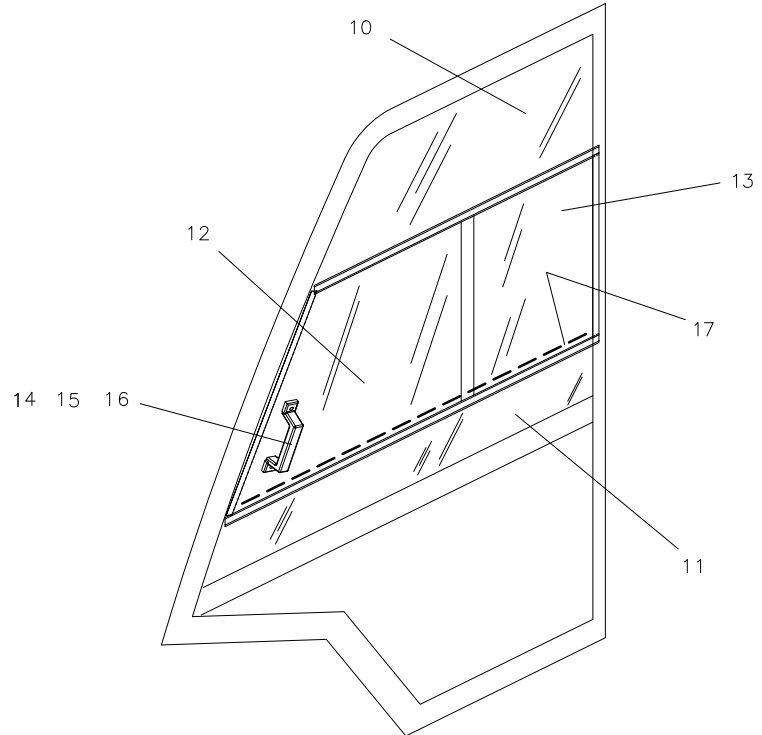

1	CAB DETAILS 5, 100 IN. FULLY ENCLOSED		QUANTITY / MODEL											8 AA 467			
			M30-4T	M40-4T	M50-4T		M30-4T H	M40-4T H	M50-4T H		M30-4T L	M40-4T L	M50-4T L		M30-4T HL	M40-4T HL	M50-4T HL
ITEM	PART NO.	DESCRIPTION	M30-2T	M40-2T	M50-2T		M30-2T H	M40-2T H	M50-2T H		M30-2T L	M40-2T L	M50-2T L		M30-2T HL	M40-2T HL	M50-2T HL
1	561088	Upper glass door, stripped, RH	1	1	1	1	1	1	1	1	1	1	1	1	1	1	1
2	561090	Lower glass door, stripped, RH	1	1	1	1	1	1	1	1	1	1	1	1	1	1	1
3	552682	Inner handle	1	1	1	1	1	1	1	1	1	1	1	1	1	1	1
4	600833	Door, stripped, RH	1	1	1	1	1	1	1	1	1	1	1	1	1	1	1
5	550153	Hinge	2	2	2	2	2	2	2	2	2	2	2	2	2	2	2
6	199961	Greaser	2	2	2	2	2	2	2	2	2	2	2	2	2	2	2
7	199963	Axle	2	2	2	2	2	2	2	2	2	2	2	2	2	2	2
8	549222	Hinge	2	2	2	2	2	2	2	2	2	2	2	2	2	2	2
9	600834	Door, RH, complete	1	1	1	1	1	1	1	1	1	1	1	1	1	1	1
10	807556	Glass, fixed upper	2	2	2	2	2	2	2	2	2	2	2	2	2	2	2
11	807555	Glass, fixed lower	1	1	1	1	1	1	1	1	1	1	1	1	1	1	1
12	807558	Glass, sliding	1	1	1	1	1	1	1	1	1	1	1	1	1	1	1
13	807557	Glass, fixed rear	1	1	1	1	1	1	1	1	1	1	1	1	1	1	1
14	424186	Handle	1	1	1	1	1	1	1	1	1	1	1	1	1	1	1
15	184036	Screw	2	2	2	2	2	2	2	2	2	2	2	2	2	2	2
16	54232	Nut	2	2	2	2	2	2	2	2	2	2	2	2	2	2	2
17	807559	Track	1	1	1	1	1	1	1	1	1	1	1	1	1	1	1

8 AA 468

TIER III

CAB DETAILS 6, 100 IN. FULLY ENCLOSED

M30-2T	M30-4T	M30-2T H	M30-4T H
M40-2T	M40-4T	M40-2T H	M40-4T H
M50-2T	M50-4T	M50-2T H	M50-4T H
M30-2T L	M30-4T L	M30-2T H L	M30-4T H L
M40-2T L	M40-4T L	M40-2T H L	M40-4T H L
M50-2T L	M50-4T L	M50-2T H L	M50-4T H L

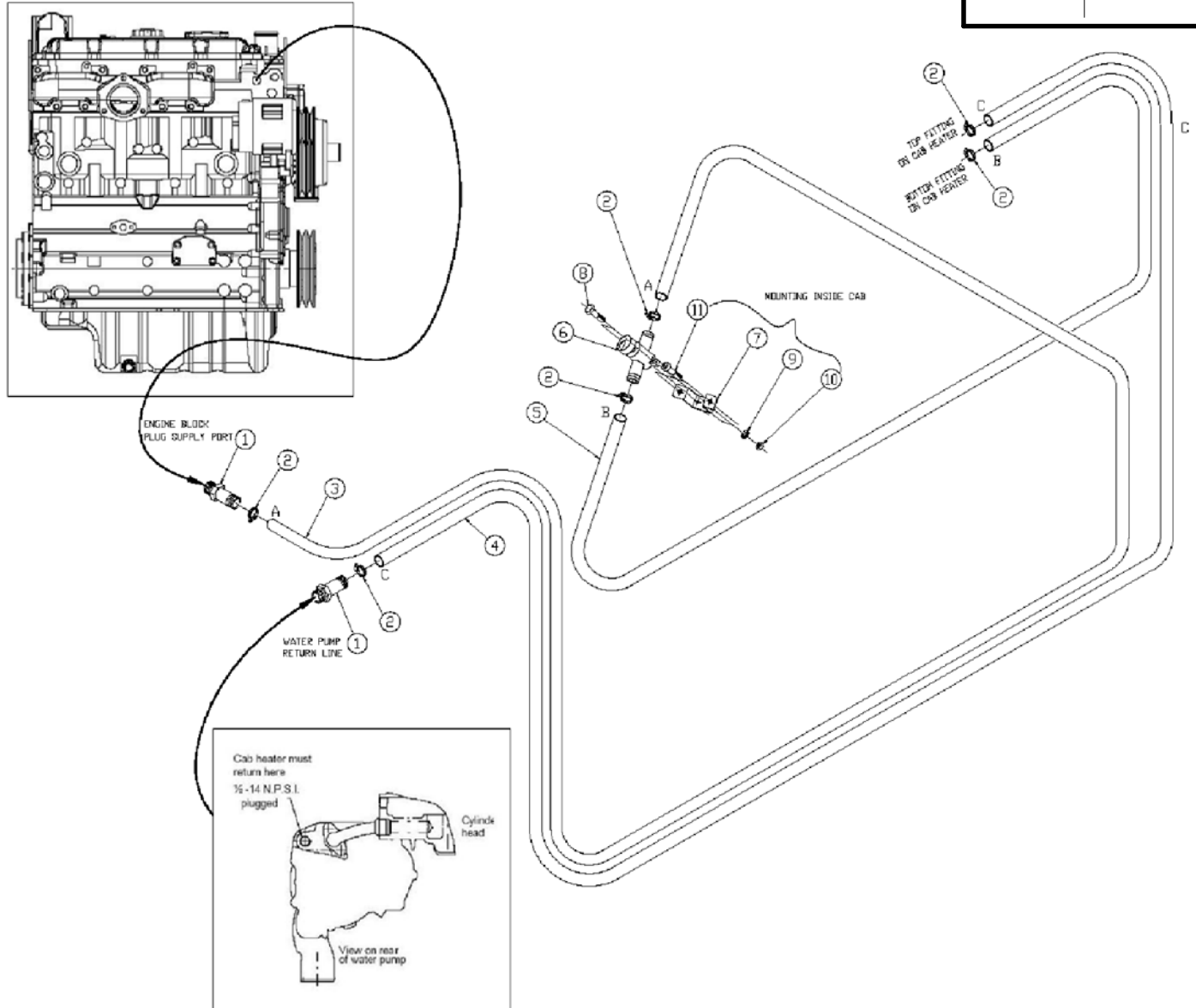

ENGINE BLOCK
PLUG SUPPLY PORT

WATER PUMP
RETURN LINE

MOUNTING INSIDE CAB

TOP FITTING
ON CAB HEATER

BOTTOM FITTING
ON CAB HEATER

Cab heater must
return here
1/2-14 N.P.S.L.
plugged

Cylinder
head

View on rear
of water pump

			QUANTITY / MODEL											8 AA 468			
			M30-4T	M40-4T	M50-4T		M30-4T H	M40-4T H	M50-4T H		M30-4T L	M40-4T L	M50-4T L		M30-4T HL	M40-4T HL	M50-4T HL
1	CAB DETAILS 6, 100 IN. FULLY ENCLOSED		M30-2T	M40-2T	M50-2T		M30-2T H	M40-2T H	M50-2T H		M30-2T L	M40-2T L	M50-2T L		M30-2T HL	M40-2T HL	M50-2T HL
ITEM	PART NO.	DESCRIPTION															
1	198059	Connection	2	2	2	2	2	2	2	2	2	2	2	2	2	2	2
2	B2236-3	Clamp	6	6	6	6	6	6	6	6	6	6	6	6	6	6	6
3	802820	Heater hose	1	1	1	1	1	1	1	1	1	1	1	1	1	1	1
4	802821	Heater hose	1	1	1	1	1	1	1	1	1	1	1	1	1	1	1
5	802822	Heater hose	1	1	1	1	1	1	1	1	1	1	1	1	1	1	1
6	198060	Valve, heater	1	1	1	1	1	1	1	1	1	1	1	1	1	1	1
7	196821	Bracket	1	1	1	1	1	1	1	1	1	1	1	1	1	1	1
8	4240	Screw	2	2	2	2	2	2	2	2	2	2	2	2	2	2	2
9	29483	Washer	2	2	2	2	2	2	2	2	2	2	2	2	2	2	2
10	54232	Nut	2	2	2	2	2	2	2	2	2	2	2	2	2	2	2
11	79533	Screw	2	2	2	2	2	2	2	2	2	2	2	2	2	2	2

8 AA 504
TIER III

CAB ASSEMBLY, 100 IN. OPEN

M30-2T	M30-4T	M30-2T H	M30-4T H
M40-2T	M40-4T	M40-2T H	M40-4T H
M50-2T	M50-4T	M50-2T H	M50-4T H
M30-2T L	M30-4T L	M30-2T H L	M30-4T H L
M40-2T L	M40-4T L	M40-2T H L	M40-4T H L
M50-2T L	M50-4T L	M50-2T H L	M50-4T H L

CAB ASSEMBLY INCLUDES WIRING FOR CAB LIGHTS
(SEE ITEM 10)

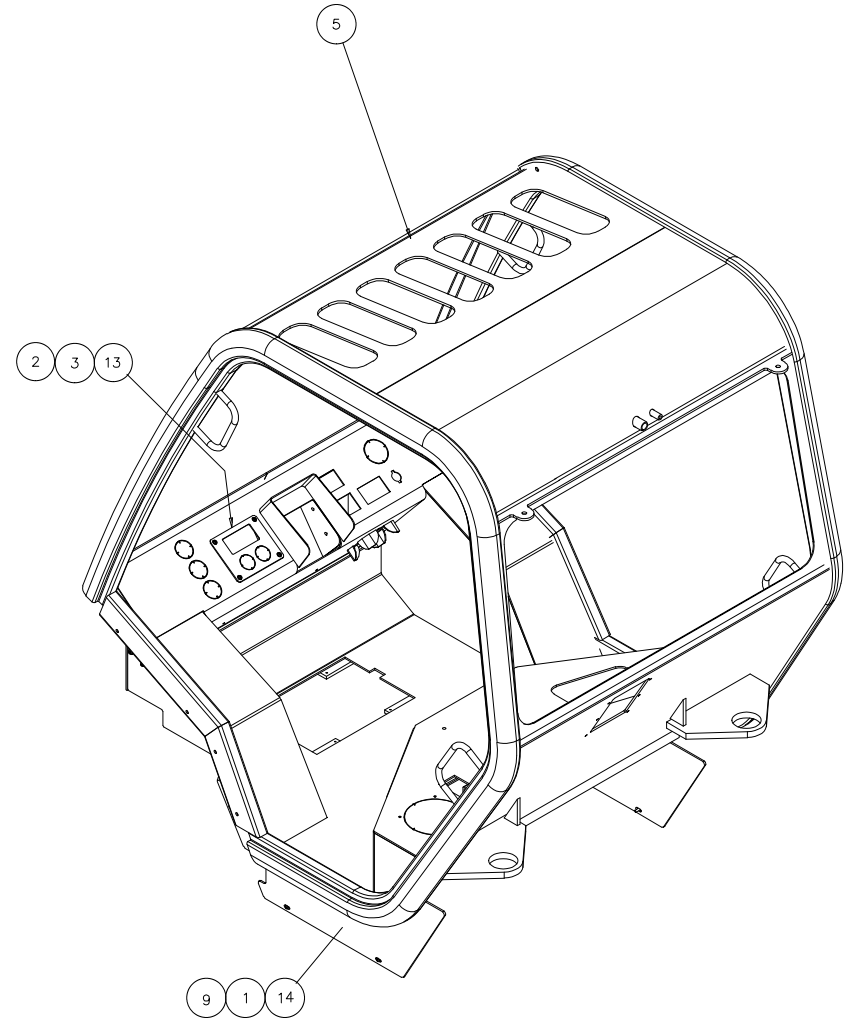
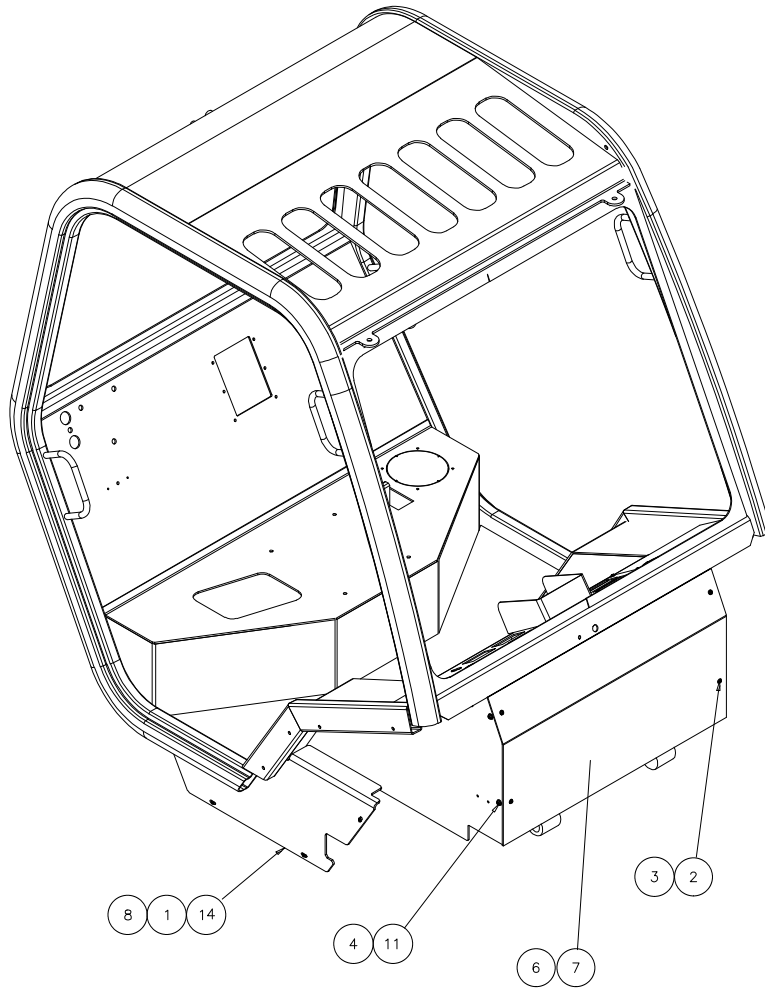

1	CAB ASSEMBLY, 100 IN. OPEN		QUANTITY / MODEL												8 AA 504		
			M30-4T	M40-4T	M50-4T		M30-4T H	M40-4T H	M50-4T H		M30-4T L	M40-4T L	M50-4T L		M30-4T HL	M40-4T HL	M50-4T HL
ITEM	PART NO.	DESCRIPTION	M30-2T	M40-2T	M50-2T		M30-2T H	M40-2T H	M50-2T H		M30-2T L	M40-2T L	M50-2T L		M30-2T HL	M40-2T HL	M50-2T HL
1	25713	Bolt	6	6	6	6	6	6	6	6	6	6	6	6	6	6	6
2	189172	Screw	8	8	8	8	8	8	8	8	8	8	8	8	8	8	8
3	29469	Washer	8	8	8	8	8	8	8	8	8	8	8	8	8	8	8
4	61674	Washer	4	4	4	4	4	4	4	4	4	4	4	4	4	4	4
5	807376	Cab assembly, 100 in. open	1	1	1	1	1	1	1	1	1	1	1	1	1	1	1
6	807724	Cover, front	1	1	1	1	1	1	1	1	1	1	1	1	1	1	1
7	802771	Angle	4	4	4	4	4	4	4	4	4	4	4	4	4	4	4
8	804782	Cover, cab RH	1	1	1	1	1	1	1	1	1	1	1	1	1	1	1
9	804781	Cover, cab LH	1	1	1	1	1	1	1	1	1	1	1	1	1	1	1
10	807723	Harness, cab - see 11CC189	1	1	1	1	1	1	1	1	1	1	1	1	1	1	1
14	25714	Nut	2	2	2	2	2	2	2	2	2	2	2	2	2	2	2
11	202731	Screw	4	4	4	4	4	4	4	4	4	4	4	4	4	4	4
13	802755	Plate, gauges	1	1	1	1	1	1	1	1	1	1	1	1	1	1	1
14	42316	Washer, lock	6	6	6	6	6	6	6	6	6	6	6	6	6	6	6

8 AA 663

TIER III

CAB ASSEMBLY, 77 & 81 IN. 4-SPEED

M30-2T	M30-4T		
M40-2T	M40-4T		
M50-2T	M50-4T		
M30-2T L	M30-4T L		
M40-2T L	M40-4T L		
M50-2T L	M50-4T L		

CAB ASSEMBLY INCLUDES WIRING FOR CAB LIGHTS
(SEE ITEM 4)

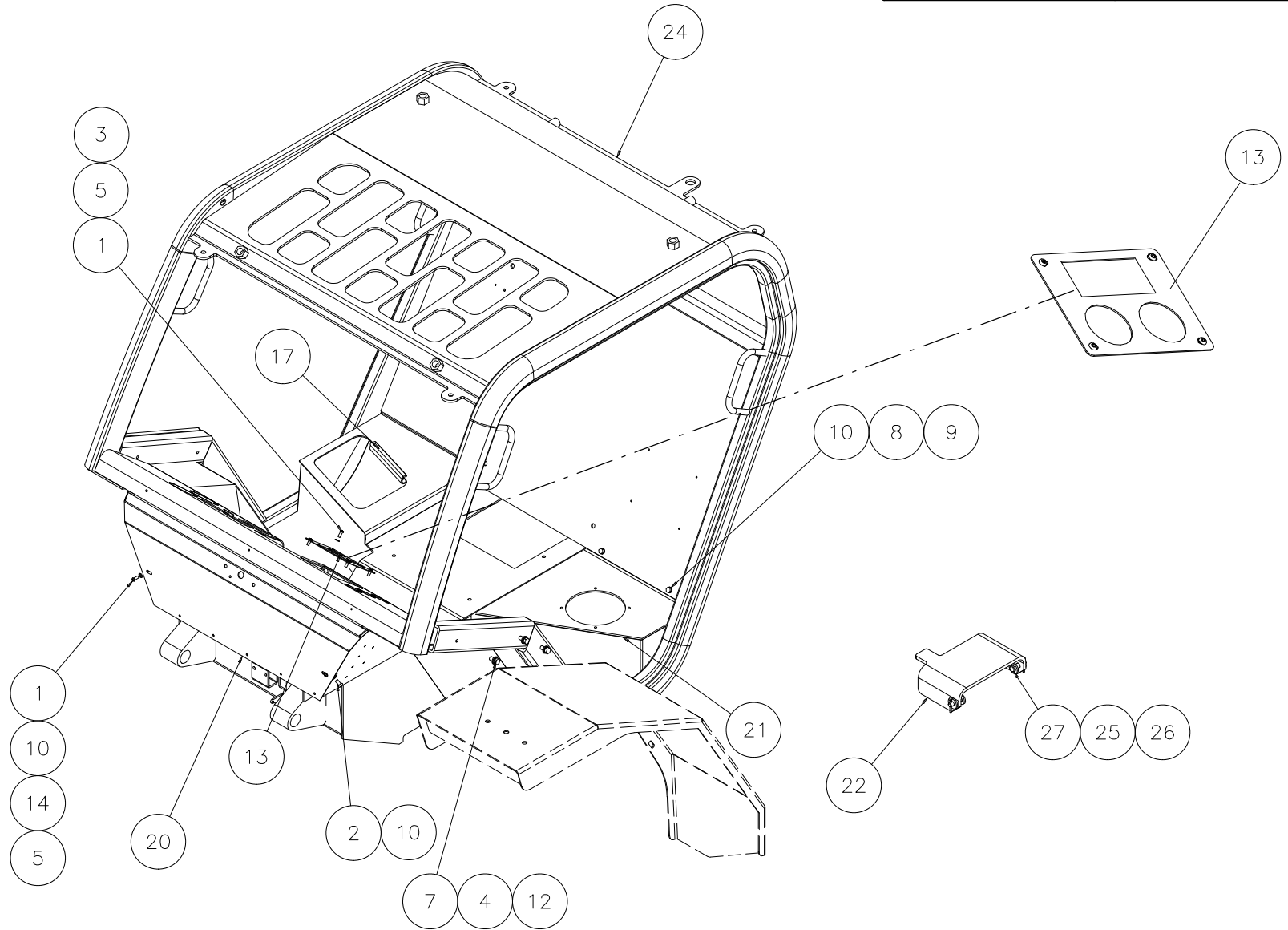

			QUANTITY / MODEL										8 AA 663					
1 CAB ASSEMBLY, 77 & 81 IN. 4-SPEED			M30-4T	M40-4T	M50-4T						M30-4T L	M40-4T L	M50-4T L					
ITEM	PART NO.	DESCRIPTION	M30-2T	M40-2T	M50-2T						M30-2T L	M40-2T L	M50-2T L					
1	189172	Screw	6	6	6	6					6	6	6	6				
2	202731	Screw	2	2	2	2					2	2	2	2				
3	25714	Nut	4	4	4	4					4	4	4	4				
5	29469	Washer, flat	6	6	6	6					6	6	6	6				
8	57446	Bolt	4	4	4	4					4	4	4	4				
9	58528	Nut	4	4	4	4					4	4	4	4				
10	61674	Washer, flat	10	10	10	10					10	10	10	10				
13	802755	Plate, gauge	1	1	1	1					1	1	1	1				
14	802771	Angle	2	2	2	2					2	2	2	2				
15	807723	Harness, cab - see 11CC189	1	1	1	1					1	1	1	1				
17	803393	Seal	1	1	1	1					1	1	1	1				
20	803663	Cover, front	1	1	1	1					1	1	1	1				
21	804272	Cover assembly	1	1	1	1					1	1	1	1				
22	805685	Cover, diff lock	1	1	1	1					1	1	1	1				
24	807449	Cab assembly	1	1	1	1					1	1	1	1				
25	K44719	Washer, flat	4	4	4	4					4	4	4	4				
26	K72016	Pin	2	2	2	2					2	2	2	2				
27	K76176	Pin, clevis	2	2	2	2					2	2	2	2				

8 AA 664
TIER III

CAB ASSEMBLY, 77 & 81 IN. HYDROSTATIC

CAB ASSEMBLY INCLUDES WIRING FOR CAB LIGHTS
(SEE ITEM 4)

M30-2T H	M30-4T H
M40-2T H	M40-4T H
M50-2T H	M50-4T H

M30-2T H L	M30-4T H L
M40-2T H L	M40-4T H L
M50-2T H L	M50-4T H L

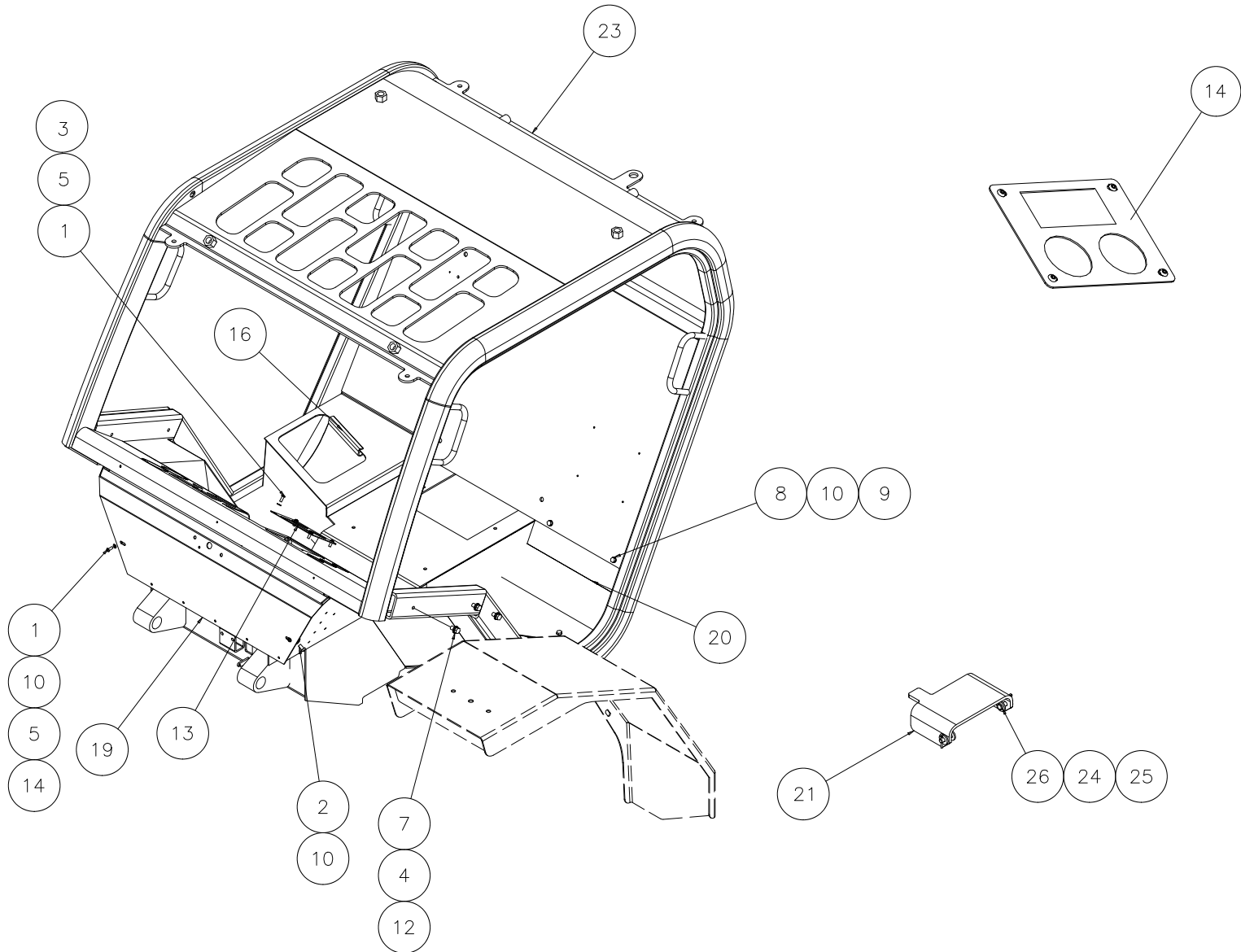

1	CAB ASSEMBLY, 77 & 81 IN. HYDROSTATIC		QUANTITY / MODEL								8 AA 664			
ITEM	PART NO.	DESCRIPTION	M30-2T H	M40-2T H	M50-2T H							M30-4T HL	M40-4T HL	M50-4T HL
1	189172	Screw	6	6	6	6						6	6	6
2	202731	Screw	2	2	2	2						2	2	2
3	25714	Nut	4	4	4	4						4	4	4
5	29469	Washer, flat	6	6	6	6						6	6	6
8	57446	Bolt	4	4	4	4						4	4	4
9	58528	Nut	4	4	4	4						4	4	4
10	61674	Washer, flat	10	10	10	10						10	10	10
13	802755	Plate, gauge	1	1	1	1						1	1	1
14	802771	Angle	2	2	2	2						2	2	2
15	807723	Harness, cab - see 11CC189	1	1	1	1						1	1	1
16	803393	Seal	1	1	1	1						1	1	1
19	803663	Cover, front	1	1	1	1						1	1	1
20	804272	Cover assembly	1	1	1	1						1	1	1
21	804274	Cover, diff lock	1	1	1	1						1	1	1
23	807449	Cab assembly	1	1	1	1						1	1	1
24	K44719	Washer, flat	4	4	4	4						4	4	4
25	K72016	Pin	2	2	2	2						2	2	2
26	K76176	Pin, clevis	2	2	2	2						2	2	2

8 AA 472
TIER III

CAB MOUNTING ASSEMBLY

M30-2T	M30-4T	M30-2T H	M30-4T H
M40-2T	M40-4T	M40-2T H	M40-4T H
M50-2T	M50-4T	M50-2T H	M50-4T H
M30-2T L	M30-4T L	M30-2T H L	M30-4T H L
M40-2T L	M40-4T L	M40-2T H L	M40-4T H L
M50-2T L	M50-4T L	M50-2T H L	M50-4T H L

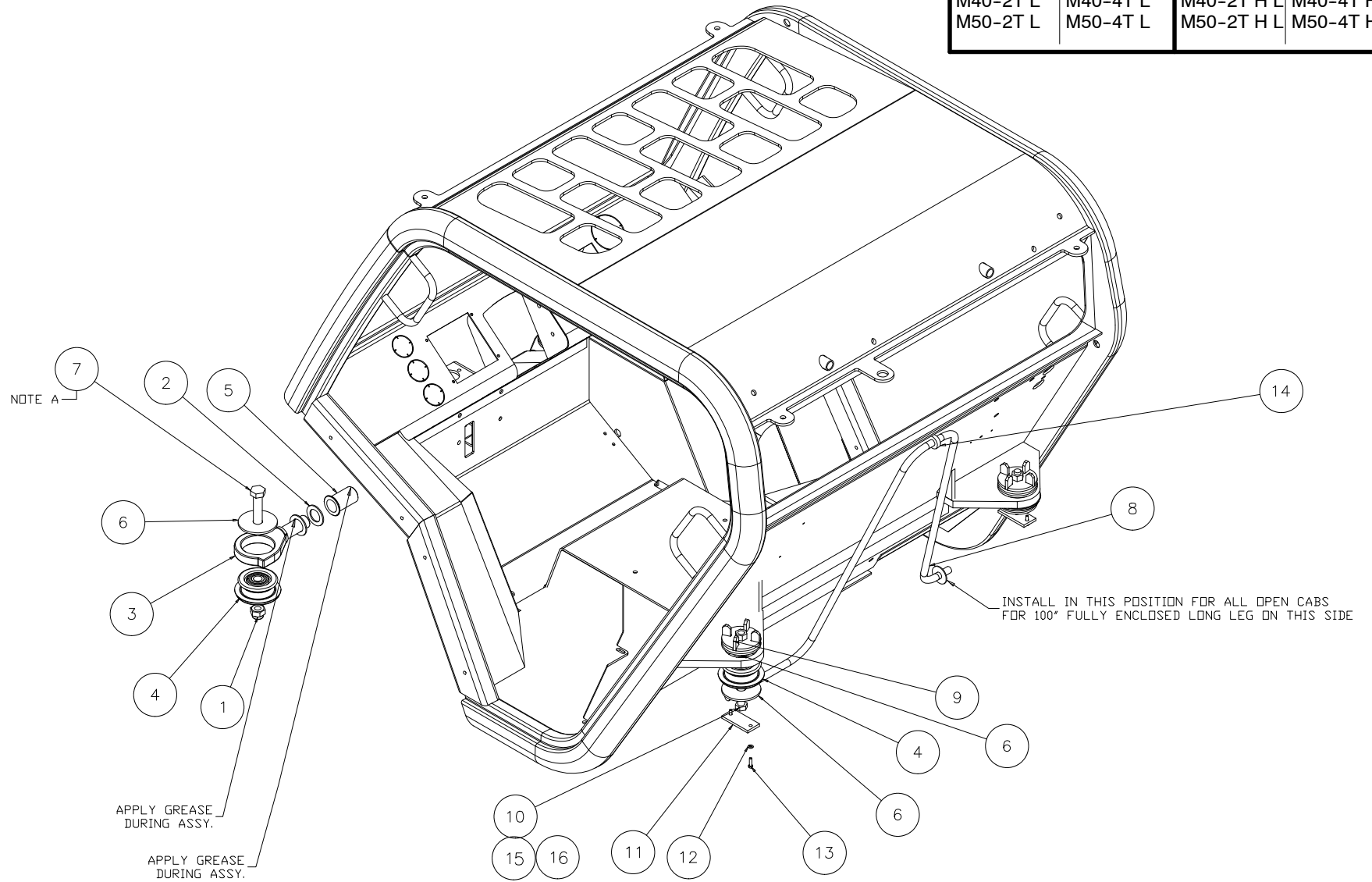

NOTE A: TORQUE TO 265 FT LB ± 26 FT LB
4 PLACES.

1	CAB MOUNTING ASSEMBLY											QUANTITY / MODEL						8 AA 472		
	ITEM	PART NO.	DESCRIPTION	M30-4T	M40-4T	M50-4T		M30-4T H	M40-4T H	M50-4T H		M30-4T L	M40-4T L	M50-4T L		M30-4T HL	M40-4T HL	M50-4T HL		
				M30-2T	M40-2T	M50-2T		M30-2T H	M40-2T H	M50-2T H		M30-2T L	M40-2T L	M50-2T L		M30-2T HL	M40-2T HL	M50-2T HL		
1	185054	Nut		4	4	4	4	4	4	4	4	4	4	4	4	4	4	4		
2	202947	Washer		4	4	4	4	4	4	4	4	4	4	4	4	4	4	4		
3	207783	Bracket, cab mounting		2	2	2	2	2	2	2	2	2	2	2	2	2	2	2		
4	209113	Rubber mount		4	4	4	4	4	4	4	4	4	4	4	4	4	4	4		
5	210005	Bushing		2	2	2	2	2	2	2	2	2	2	2	2	2	2	2		
6	210006	Washer, flat		6	6	6	6	6	6	6	6	6	6	6	6	6	6	6		
7	58633	Bolt		4	4	4	4	4	4	4	4	4	4	4	4	4	4	4		
8	806993	Tilt stand		1	1	1	1	1	1	1	1	1	1	1	1	1	1	1		
9	803723	Wing nut		2	2	2	2	2	2	2	2	2	2	2	2	2	2	2		
10	K45840	Bolt, 4 in. long		2	2	2	2	2	2	2	2	2	2	2	2	2	2	2		
11	804358	Plate, cover		2	2	2	2	2	2	2	2	2	2	2	2	2	2	2		
12	42316	Washer, lock		4	4	4	4	4	4	4	4	4	4	4	4	4	4	4		
13	46668	Bolt		4	4	4	4	4	4	4	4	4	4	4	4	4	4	4		
14	82520	Grommet		1	1	1	1	1	1	1	1	1	1	1	1	1	1	1		
15	K45894	Bolt, 5 1/2 in. long (use with Item 16)		2	2	2	2	2	2	2	2	2	2	2	2	2	2	2		
16	807957	Washer, 1 in. thick (use with Item 15)		2	2	2	2	2	2	2	2	2	2	2	2	2	2	2		

8 AA 473
TIER III

**STEERING COLUMN ASSEMBLY,
100 IN. SEMI & FULLY ENCLOSED CAB**

M30-2T	M30-4T	M30-2T H	M30-4T H
M40-2T	M40-4T	M40-2T H	M40-4T H
M50-2T	M50-4T	M50-2T H	M50-4T H
M30-2T L	M30-4T L	M30-2T H L	M30-4T H L
M40-2T L	M40-4T L	M40-2T H L	M40-4T H L
M50-2T L	M50-4T L	M50-2T H L	M50-4T H L

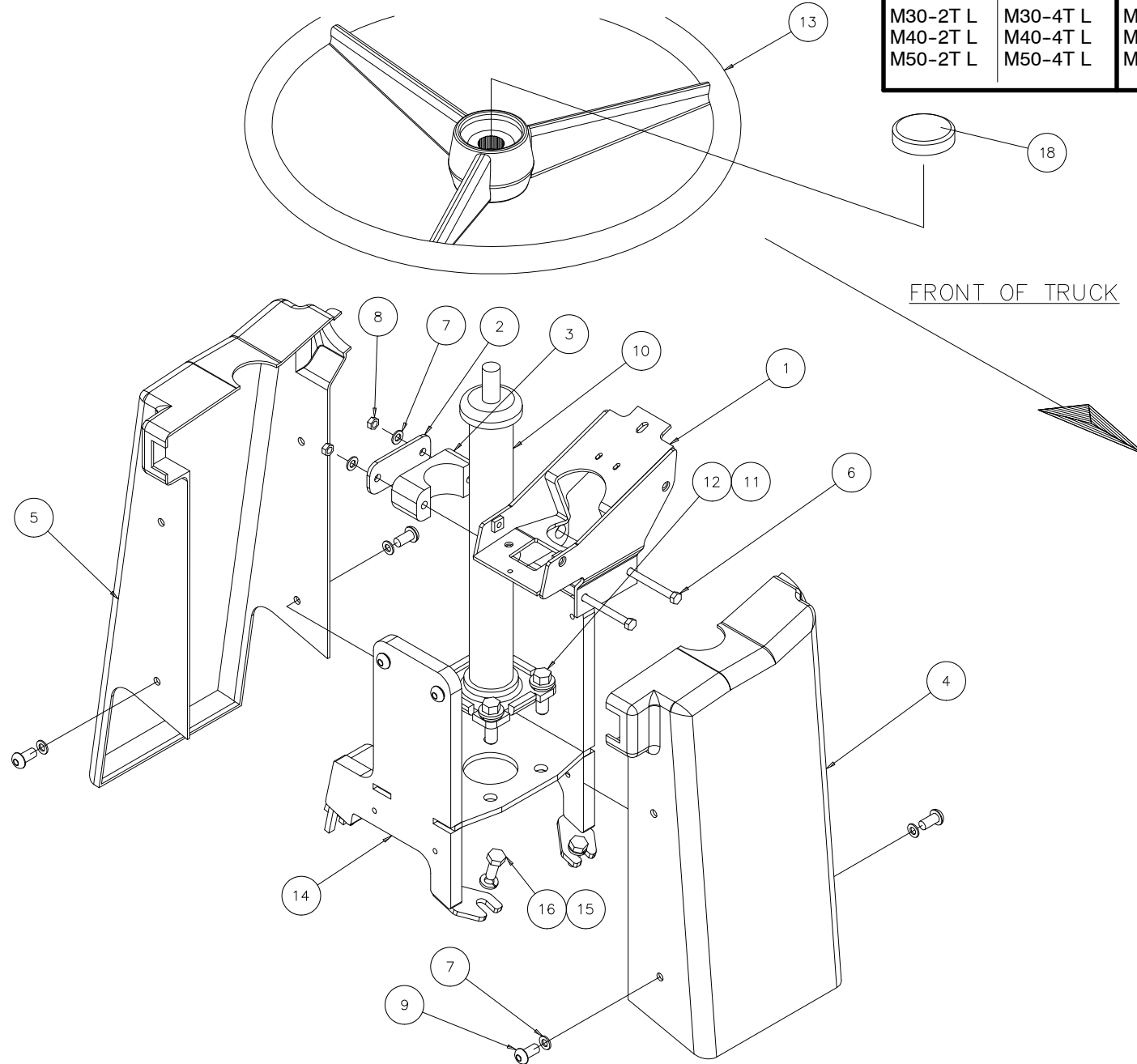

1	STEERING COLUMN ASSEMBLY, 100 IN. SEMI & FULLY ENCLOSED CAB		QUANTITY / MODEL											8 AA 473				
			M30-4T	M40-4T	M50-4T		M30-4T H	M40-4T H	M50-4T H		M30-4T L	M40-4T L	M50-4T L		M30-4T HL	M40-4T HL	M50-4T HL	
			M30-2T	M40-2T	M50-2T		M30-2T H	M40-2T H	M50-2T H		M30-2T L	M40-2T L	M50-2T L		M30-2T HL	M40-2T HL	M50-2T HL	
ITEM	PART NO.	DESCRIPTION	M30-2T	M40-2T	M50-2T		M30-2T H	M40-2T H	M50-2T H		M30-2T L	M40-2T L	M50-2T L		M30-2T HL	M40-2T HL	M50-2T HL	
1	203115	Bracket, steering column	1	1	1	1	1	1	1	1	1	1	1	1	1	1	1	1
2	168870	Plate, cover	1	1	1	1	1	1	1	1	1	1	1	1	1	1	1	1
3	174321	Clamp, hose half	2	2	2	2	2	2	2	2	2	2	2	2	2	2	2	2
4	202953	Cover, column front	1	1	1	1	1	1	1	1	1	1	1	1	1	1	1	1
5	202954	Cover, column rear	1	1	1	1	1	1	1	1	1	1	1	1	1	1	1	1
6	165919	Bolt	2	2	2	2	2	2	2	2	2	2	2	2	2	2	2	2
7	29469	Washer, flat	2	2	2	2	2	2	2	2	2	2	2	2	2	2	2	2
8	162229	Nut	2	2	2	2	2	2	2	2	2	2	2	2	2	2	2	2
9	196951	Screw	8	8	8	8	8	8	8	8	8	8	8	8	8	8	8	8
10	30327	Column, steering	1	1	1	1	1	1	1	1	1	1	1	1	1	1	1	1
11	42232	Washer, lock	4	4	4	4	4	4	4	4	4	4	4	4	4	4	4	4
12	63544	Bolt	4	4	4	4	4	4	4	4	4	4	4	4	4	4	4	4
13	191613	Steering wheel	1	1	1	1	1	1	1	1	1	1	1	1	1	1	1	1
14	216000	Bracket, steering	1	1	1	1	1	1	1	1	1	1	1	1	1	1	1	1
15	42325	Washer, lock	4	4	4	4	4	4	4	4	4	4	4	4	4	4	4	4
16	42347	Bolt	4	4	4	4	4	4	4	4	4	4	4	4	4	4	4	4
17	195069	Steering wheel cap	1	1	1	1	1	1	1	1	1	1	1	1	1	1	1	1

40.00

8 AA 474

TIER III

STEERING COLUMN ASSEMBLY, 100 IN. OPEN CAB

M30-2T	M30-4T	M30-2T H	M30-4T H
M40-2T	M40-4T	M40-2T H	M40-4T H
M50-2T	M50-4T	M50-2T H	M50-4T H
M30-2T L	M30-4T L	M30-2T H L	M30-4T H L
M40-2T L	M40-4T L	M40-2T H L	M40-4T H L
M50-2T L	M50-4T L	M50-2T H L	M50-4T H L

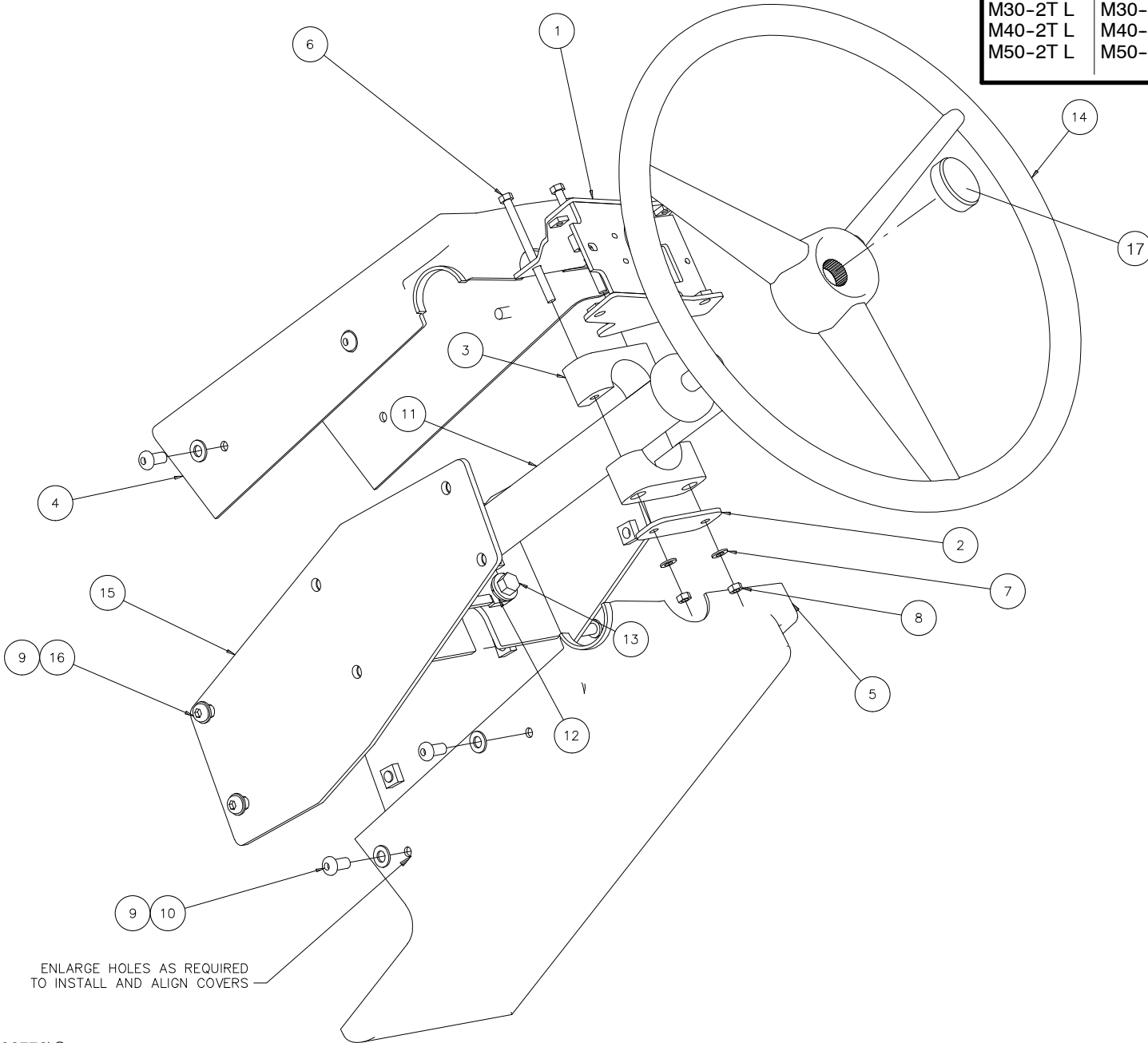

ENLARGE HOLES AS REQUIRED
TO INSTALL AND ALIGN COVERS

1	STEERING COLUMN ASSEMBLY, 100 IN. OPEN CAB		QUANTITY / MODEL												8 AA 474			
			M30-4T	M40-4T	M50-4T		M30-4T H	M40-4T H	M50-4T H		M30-4T L	M40-4T L	M50-4T L		M30-4T HL	M40-4T HL	M50-4T HL	
ITEM	PART NO.	DESCRIPTION	M30-2T	M40-2T	M50-2T		M30-2T H	M40-2T H	M50-2T H		M30-2T L	M40-2T L	M50-2T L		M30-2T HL	M40-2T HL	M50-2T HL	
1	203115	Bracket, steering column	1	1	1	1	1	1	1	1	1	1	1	1	1	1	1	1
2	168870	Plate, cover	1	1	1	1	1	1	1	1	1	1	1	1	1	1	1	1
3	174321	Clamp, hose half	2	2	2	2	2	2	2	2	2	2	2	2	2	2	2	2
4	202953	Cover, column front	1	1	1	1	1	1	1	1	1	1	1	1	1	1	1	1
5	202954	Cover, column rear	1	1	1	1	1	1	1	1	1	1	1	1	1	1	1	1
6	165919	Bolt	2	2	2	2	2	2	2	2	2	2	2	2	2	2	2	2
7	29469	Washer, flat	2	2	2	2	2	2	2	2	2	2	2	2	2	2	2	2
8	162229	Nut	2	2	2	2	2	2	2	2	2	2	2	2	2	2	2	2
9	61674	Washer, flat	12	12	12	12	12	12	12	12	12	12	12	12	12	12	12	12
10	202731	Screw	8	8	8	8	8	8	8	8	8	8	8	8	8	8	8	8
11	30327	Column, steering	1	1	1	1	1	1	1	1	1	1	1	1	1	1	1	1
12	42232	Washer, lock	4	4	4	4	4	4	4	4	4	4	4	4	4	4	4	4
13	63544	Bolt	4	4	4	4	4	4	4	4	4	4	4	4	4	4	4	4
14	191613	Steering wheel	1	1	1	1	1	1	1	1	1	1	1	1	1	1	1	1
15	803077	Column assembly	1	1	1	1	1	1	1	1	1	1	1	1	1	1	1	1
16	202144	Screw	4	4	4	4	4	4	4	4	4	4	4	4	4	4	4	4
17	195069	Steering wheel cap	1	1	1	1	1	1	1	1	1	1	1	1	1	1	1	1

8 AA 475
TIER III

STEERING COLUMN ASSEMBLY, 81 & 77 IN. CAB

M30-2T	M30-4T	M30-2T H	M30-4T H
M40-2T	M40-4T	M40-2T H	M40-4T H
M50-2T	M50-4T	M50-2T H	M50-4T H
M30-2T L	M30-4T L	M30-2T H L	M30-4T H L
M40-2T L	M40-4T L	M40-2T H L	M40-4T H L
M50-2T L	M50-4T L	M50-2T H L	M50-4T H L

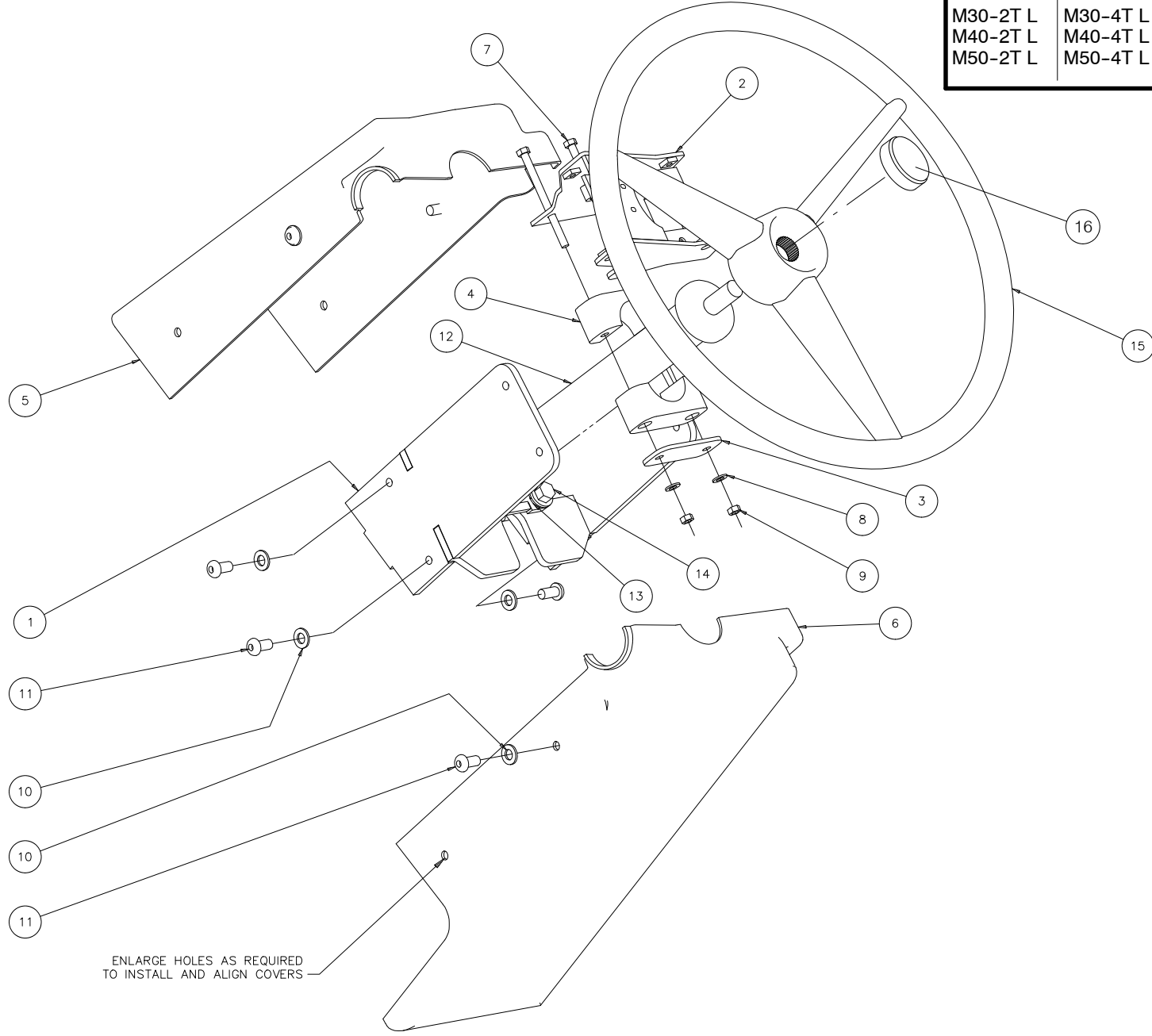

1	STEERING COLUMN ASSEMBLY, 81 & 77 IN. CAB		QUANTITY / MODEL											8 AA 475			
			M30-4T	M40-4T	M50-4T		M30-4T H	M40-4T H	M50-4T H		M30-4T L	M40-4T L	M50-4T L		M30-4T HL	M40-4T HL	M50-4T HL
ITEM	PART NO.	DESCRIPTION	M30-2T	M40-2T	M50-2T		M30-2T H	M40-2T H	M50-2T H		M30-2T L	M40-2T L	M50-2T L		M30-2T HL	M40-2T HL	M50-2T HL
1	802025	Steering mount assembly	1	1	1	1	1	1	1	1	1	1	1	1	1	1	1
2	203115	Bracket, steering column	1	1	1	1	1	1	1	1	1	1	1	1	1	1	1
3	168870	Plate, cover	1	1	1	1	1	1	1	1	1	1	1	1	1	1	1
4	174321	Clamp, hose half	2	2	2	2	2	2	2	2	2	2	2	2	2	2	2
5	202953	Cover, column front	1	1	1	1	1	1	1	1	1	1	1	1	1	1	1
6	202954	Cover, column rear	1	1	1	1	1	1	1	1	1	1	1	1	1	1	1
7	165919	Bolt	2	2	2	2	2	2	2	2	2	2	2	2	2	2	2
8	29469	Washer, flat	2	2	2	2	2	2	2	2	2	2	2	2	2	2	2
9	162229	Nut	2	2	2	2	2	2	2	2	2	2	2	2	2	2	2
10	61674	Washer, flat	8	8	8	8	8	8	8	8	8	8	8	8	8	8	8
11	202731	Screw	8	8	8	8	8	8	8	8	8	8	8	8	8	8	8
12	30327	Column, steering	1	1	1	1	1	1	1	1	1	1	1	1	1	1	1
13	42232	Washer, lock	4	4	4	4	4	4	4	4	4	4	4	4	4	4	4
14	63544	Bolt	4	4	4	4	4	4	4	4	4	4	4	4	4	4	4
15	191613	Steering wheel	1	1	1	1	1	1	1	1	1	1	1	1	1	1	1
16	195069	Steering wheel cap	1	1	1	1	1	1	1	1	1	1	1	1	1	1	1

8 AA 476
TIER III

STEERING COLUMN ASSEMBLY, TILTING,
100 IN. SEMI & ENCLOSED CAB

M30-2T	M30-4T	M30-2T H	M30-4T H
M40-2T	M40-4T	M40-2T H	M40-4T H
M50-2T	M50-4T	M50-2T H	M50-4T H
M30-2T L	M30-4T L	M30-2T H L	M30-4T H L
M40-2T L	M40-4T L	M40-2T H L	M40-4T H L
M50-2T L	M50-4T L	M50-2T H L	M50-4T H L

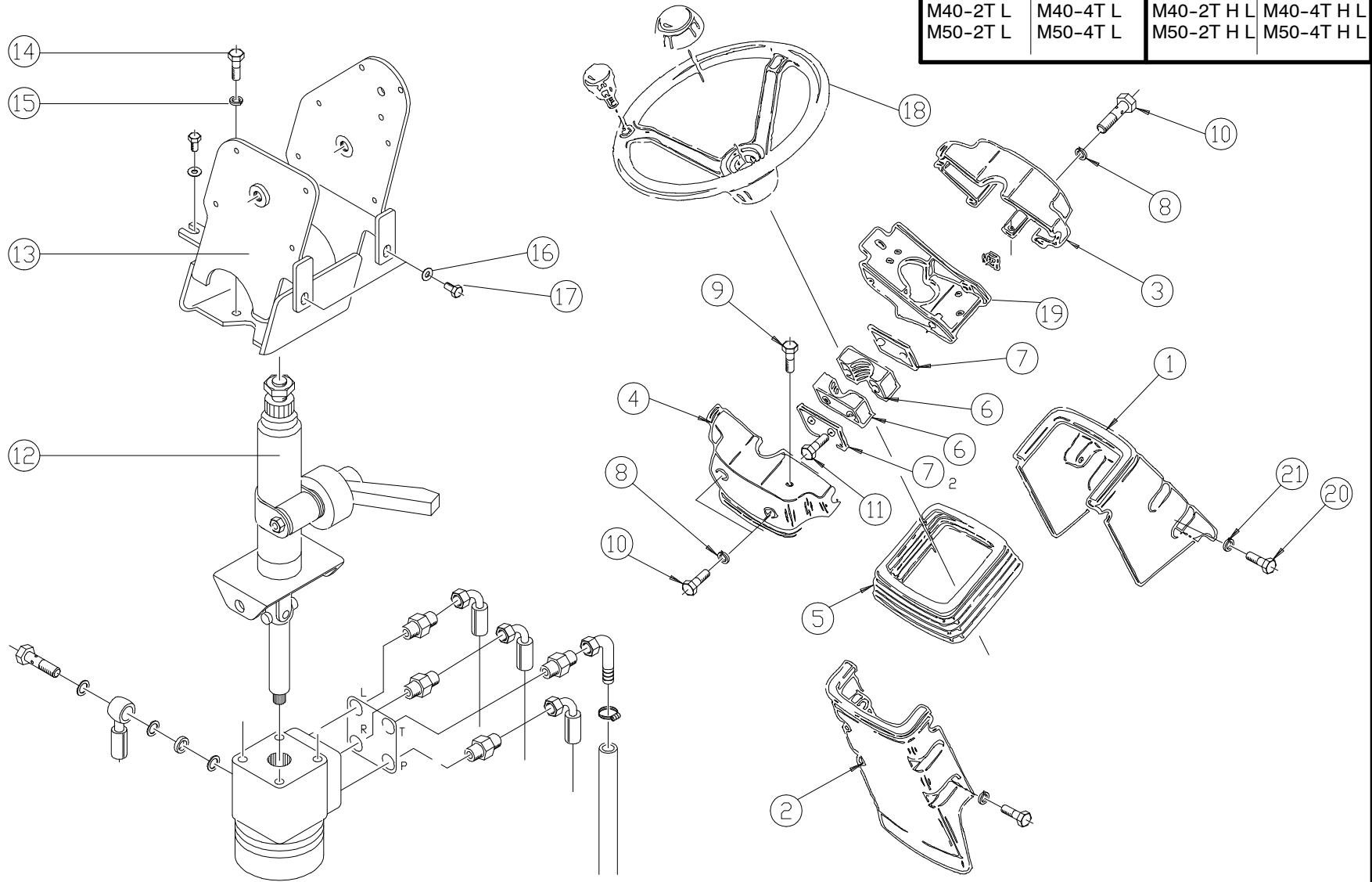

1	STEERING COLUMN ASSEMBLY, TILTING, 100 IN. SEMI & ENCLOSED CAB											QUANTITY / MODEL									8 AA 476						
												M30-4T	M40-4T	M50-4T		M30-4T H	M40-4T H	M50-4T H		M30-4T L	M40-4T L	M50-4T L		M30-4T HL	M40-4T HL	M50-4T HL	
												M30-2T	M40-2T	M50-2T		M30-2T H	M40-2T H	M50-2T H		M30-2T L	M40-2T L	M50-2T L		M30-2T HL	M40-2T HL	M50-2T HL	
ITEM	PART NO.	DESCRIPTION	M30-2T	M40-2T	M50-2T		M30-2T H	M40-2T H	M50-2T H		M30-2T L	M40-2T L	M50-2T L		M30-2T HL	M40-2T HL	M50-2T HL										
1	203123	Front cover, lower	1	1	1	1	1	1	1	1	1	1	1	1	1	1	1	1									
2	203124	Rear cover, lower	1	1	1	1	1	1	1	1	1	1	1	1	1	1	1	1									
3	203125	Front cover, upper	1	1	1	1	1	1	1	1	1	1	1	1	1	1	1	1									
4	203126	Rear cover, upper	1	1	1	1	1	1	1	1	1	1	1	1	1	1	1	1									
5	203127	Bellow	1	1	1	1	1	1	1	1	1	1	1	1	1	1	1	1									
6	173717	Half clamp	2	2	2	2	2	2	2	2	2	2	2	2	2	2	2	2									
7	177082	Half clamp plate	5	5	5	5	5	5	5	5	5	5	5	5	5	5	5	5									
8	189857	Washer	4	4	4	4	4	4	4	4	4	4	4	4	4	4	4	4									
9	78310	Bolt	1	1	1	1	1	1	1	1	1	1	1	1	1	1	1	1									
10	196951	Bolt	4	4	4	4	4	4	4	4	4	4	4	4	4	4	4	4									
11	205933	Bolt	2	2	2	2	2	2	2	2	2	2	2	2	2	2	2	2									
12	201563	Tilt column	1	1	1	1	1	1	1	1	1	1	1	1	1	1	1	1									
13	218083	Tilt column bracket	1	1	1	1	1	1	1	1	1	1	1	1	1	1	1	1									
14	5804	Bolt	4	4	4	4	4	4	4	4	4	4	4	4	4	4	4	4									
15	42232	Washer	4	4	4	4	4	4	4	4	4	4	4	4	4	4	4	4									
16	42325	Washer, lock	4	4	4	4	4	4	4	4	4	4	4	4	4	4	4	4									
17	42347	Bolt	4	4	4	4	4	4	4	4	4	4	4	4	4	4	4	4									
18	191613	Steering wheel	1	1	1	1	1	1	1	1	1	1	1	1	1	1	1	1									
19	203115	Bracket	1	1	1	1	1	1	1	1	1	1	1	1	1	1	1	1									
20	205275	Screw	4	4	4	4	4	4	4	4	4	4	4	4	4	4	4	4									
21	29469	Washer, flat	4	4	4	4	4	4	4	4	4	4	4	4	4	4	4	4									

8 AA 479
TIER III

SEAT ASSEMBLY AND REAR VIEW MIRROR, 100 IN. CAB

M30-2T	M30-4T	M30-2T H	M30-4T H
M40-2T	M40-4T	M40-2T H	M40-4T H
M50-2T	M50-4T	M50-2T H	M50-4T H
M30-2T L	M30-4T L	M30-2T H L	M30-4T H L
M40-2T L	M40-4T L	M40-2T H L	M40-4T H L
M50-2T L	M50-4T L	M50-2T H L	M50-4T H L

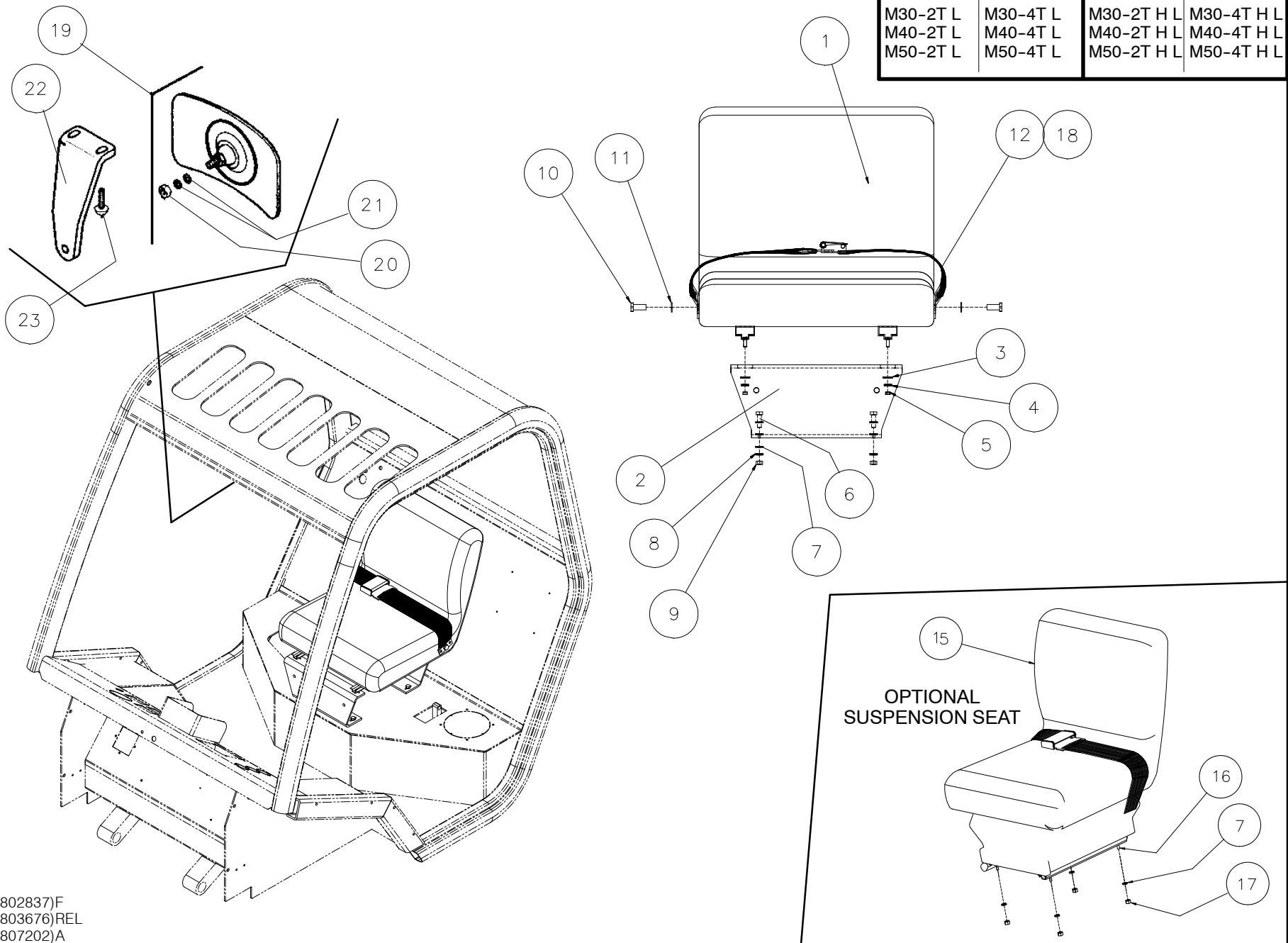

802837)F
803676)REL
807202)A

1	SEAT ASSEMBLY AND REAR VIEW MIRROR, 100 IN. CAB											QUANTITY / MODEL												8 AA 479		
	ITEM	PART NO.	DESCRIPTION	M30-4T	M40-4T	M50-4T		M30-4T H	M40-4T H	M50-4T H		M30-4T L	M40-4T L	M50-4T L		M30-4T HL	M40-4T HL	M50-4T HL								
				M30-2T	M40-2T	M50-2T		M30-2T H	M40-2T H	M50-2T H		M30-2T L	M40-2T L	M50-2T L		M30-2T HL	M40-2T HL	M50-2T HL								
1	807543	Seat assembly w/ rails	1	1	1	1	1	1	1	1	1	1	1	1	1	1	1	1	1							
2	803986	Pedestal, seat (height 5 3/4 in)	2	2	2	2	2	2	2	2	2	2	2	2	2	2	2	2	2							
2	805492	Pedestal, seat (height 3 3/4 in)	2	2	2	2	2	2	2	2	2	2	2	2	2	2	2	2	2							
3	K44877	Washer, flat	4	4	4	4	4	4	4	4	4	4	4	4	4	4	4	4	4							
4	K34791	Washer, lock	4	4	4	4	4	4	4	4	4	4	4	4	4	4	4	4	4							
5	K33770	Nut	4	4	4	4	4	4	4	4	4	4	4	4	4	4	4	4	4							
6	57446	Bolt	4	4	4	4	4	4	4	4	4	4	4	4	4	4	4	4	4							
7	61674	Washer, flat	A/R	A/R	A/R	A/R	A/R	A/R	A/R	A/R	A/R	A/R	A/R	A/R	A/R	A/R	A/R	A/R	A/R							
8	42325	Washer, lock	4	4	4	4	4	4	4	4	4	4	4	4	4	4	4	4	4							
9	58528	Nut	4	4	4	4	4	4	4	4	4	4	4	4	4	4	4	4	4							
10	K20391	Bolt	2	2	2	2	2	2	2	2	2	2	2	2	2	2	2	2	2							
11	K34808	Washer, lock	2	2	2	2	2	2	2	2	2	2	2	2	2	2	2	2	2							
12	495931	Seat belt, 3 inch wide	1	1	1	1	1	1	1	1	1	1	1	1	1	1	1	1	1							
15	191022	Seat, suspension	1	1	1	1	1	1	1	1	1	1	1	1	1	1	1	1	1							
16	42347	Bolt	4	4	4	4	4	4	4	4	4	4	4	4	4	4	4	4	4							
17	54242	Nut	4	4	4	4	4	4	4	4	4	4	4	4	4	4	4	4	4							
18	807168	Seat belt, 3 inch wide, retractable (includes hardware)	1	1	1	1	1	1	1	1	1	1	1	1	1	1	1	1	1							
19	220336	Mirror and Items 20 and 21	1	1	1	1	1	1	1	1	1	1	1	1	1	1	1	1	1							
20	58528	Nut	1	1	1	1	1	1	1	1	1	1	1	1	1	1	1	1	1							
21	42325	Washer	2	2	2	2	2	2	2	2	2	2	2	2	2	2	2	2	2							
22	561540	Bracket	1	1	1	1	1	1	1	1	1	1	1	1	1	1	1	1	1							
23	205275	Screw	2	2	2	2	2	2	2	2	2	2	2	2	2	2	2	2	2							

8 AA 480
TIER III

SEAT ASSEMBLY, LOW BACK, 77 & 81 IN. CAB

M30-2T	M30-4T	M30-2T H	M30-4T H
M40-2T	M40-4T	M40-2T H	M40-4T H
M50-2T	M50-4T	M50-2T H	M50-4T H
M30-2T L	M30-4T L	M30-2T H L	M30-4T H L
M40-2T L	M40-4T L	M40-2T H L	M40-4T H L
M50-2T L	M50-4T L	M50-2T H L	M50-4T H L

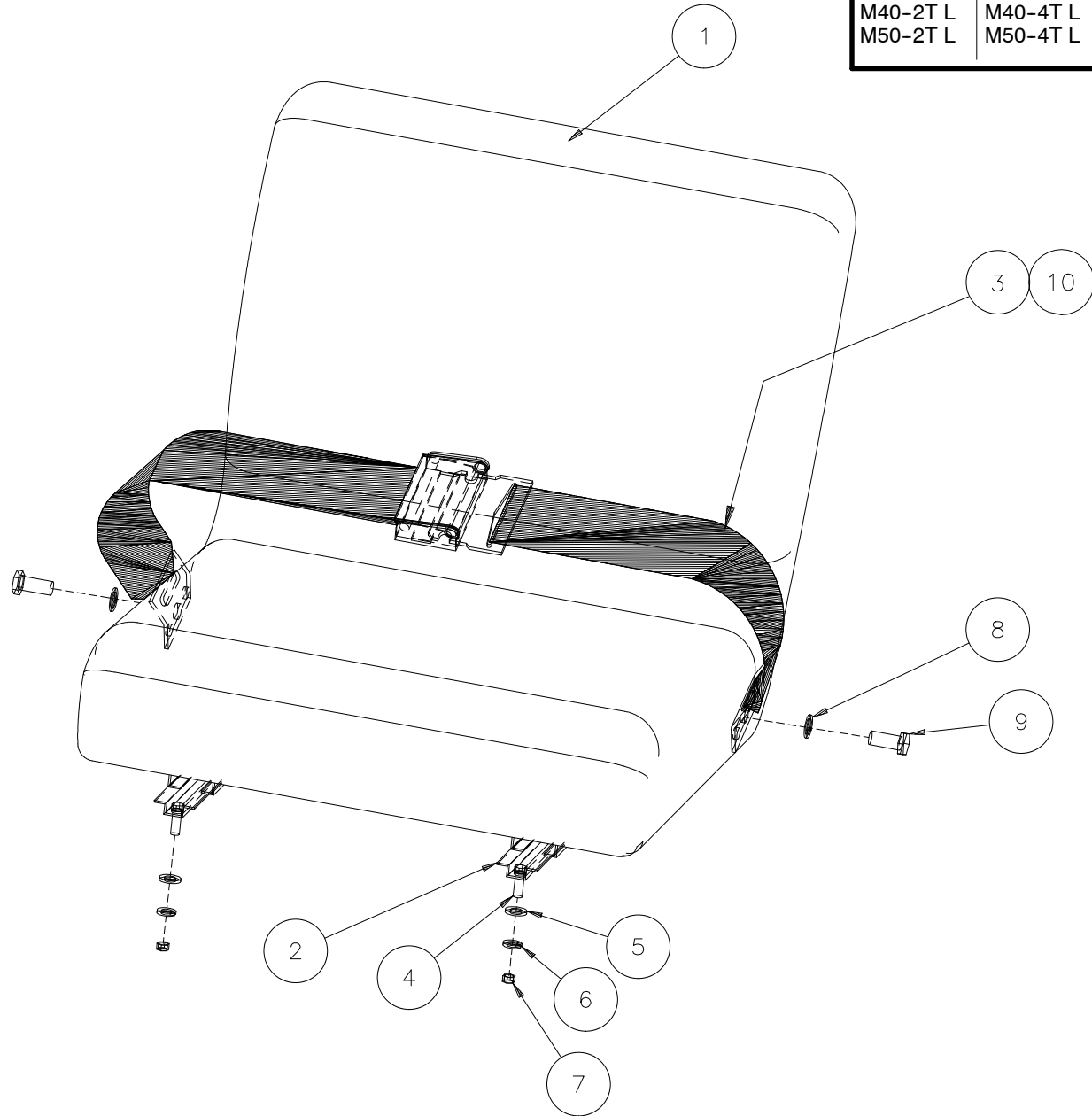

1	SEAT ASSEMBLY, LOW BACK, 77 & 81 IN. CAB		QUANTITY / MODEL												8 AA 480			
			M30-4T	M40-4T	M50-4T		M30-4T H	M40-4T H	M50-4T H		M30-4T L	M40-4T L	M50-4T L		M30-4T HL	M40-4T HL	M50-4T HL	
ITEM	PART NO.	DESCRIPTION	M30-2T	M40-2T	M50-2T		M30-2T H	M40-2T H	M50-2T H		M30-2T L	M40-2T L	M50-2T L		M30-2T HL	M40-2T HL	M50-2T HL	
1	807543	Seat, 17.5 in. height	1	1	1	1	1	1	1	1	1	1	1	1	1	1	1	1
2	802398	Rail kit, less hardware	1	1	1	1	1	1	1	1	1	1	1	1	1	1	1	1
3	495931	Seat belt, 3 in.	1	1	1	1	1	1	1	1	1	1	1	1	1	1	1	1
4	K20346SS	Bolt	4	4	4	4	4	4	4	4	4	4	4	4	4	4	4	4
5	K44722	Washer	4	4	4	4	4	4	4	4	4	4	4	4	4	4	4	4
6	K34806	Washer, lock	4	4	4	4	4	4	4	4	4	4	4	4	4	4	4	4
7	K55961	Nut, lock	4	4	4	4	4	4	4	4	4	4	4	4	4	4	4	4
8	K34808	Washer, lock	2	2	2	2	2	2	2	2	2	2	2	2	2	2	2	2
9	K20391	Bolt	2	2	2	2	2	2	2	2	2	2	2	2	2	2	2	2
10	807168	Seat belt, 3 inch wide, retractable (includes hardware)	1	1	1	1	1	1	1	1	1	1	1	1	1	1	1	1

8 AA 481
TIER III

SEAT ASSEMBLY, HIGH BACK, 77 & 81 IN. CAB

M30-2T	M30-4T	M30-2T H	M30-4T H
M40-2T	M40-4T	M40-2T H	M40-4T H
M50-2T	M50-4T	M50-2T H	M50-4T H
M30-2T L	M30-4T L	M30-2T H L	M30-4T H L
M40-2T L	M40-4T L	M40-2T H L	M40-4T H L
M50-2T L	M50-4T L	M50-2T H L	M50-4T H L

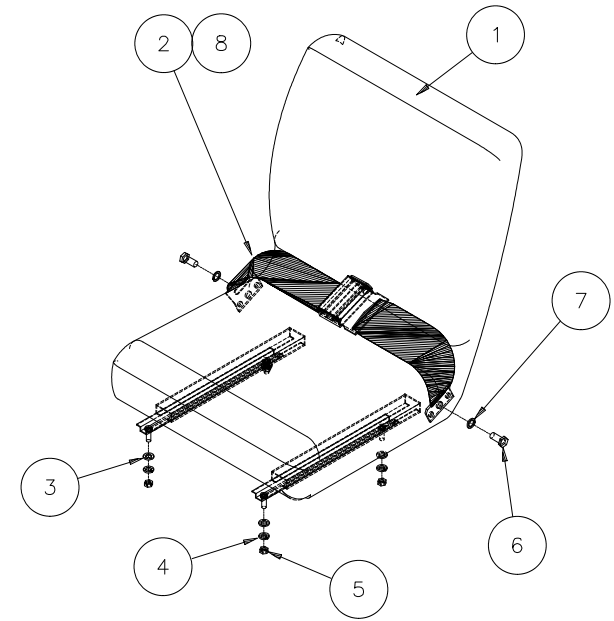
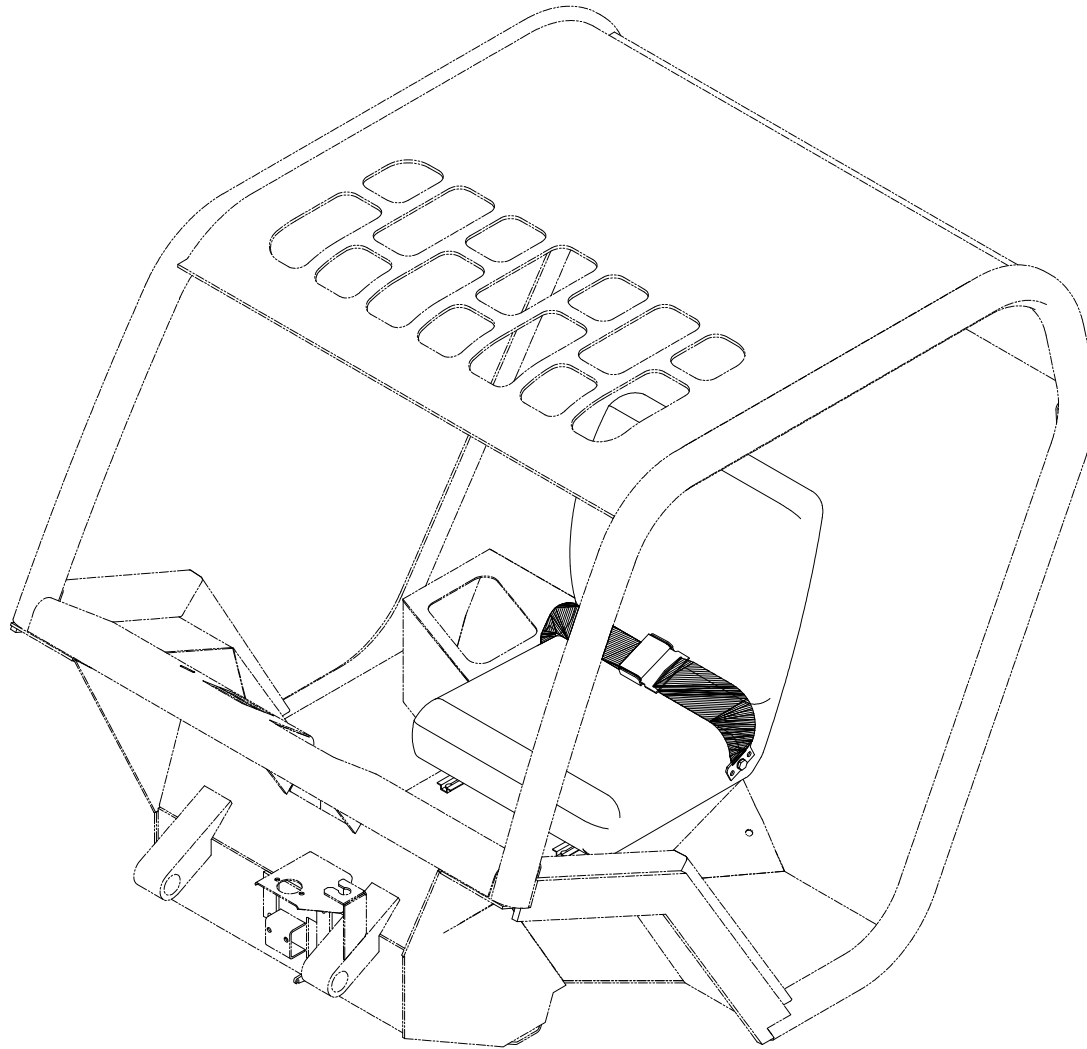

1	SEAT ASSEMBLY, HIGH BACK, 77 & 81 IN. CAB		QUANTITY / MODEL												8 AA 481			
			M30-4T	M40-4T	M50-4T		M30-4T H	M40-4T H	M50-4T H		M30-4T L	M40-4T L	M50-4T L		M30-4T HL	M40-4T HL	M50-4T HL	
ITEM	PART NO.	DESCRIPTION	M30-2T	M40-2T	M50-2T		M30-2T H	M40-2T H	M50-2T H		M30-2T L	M40-2T L	M50-2T L		M30-2T HL	M40-2T HL	M50-2T HL	
1	491746	Seat, hight back, 21.75 height	1	1	1	1	1	1	1	1	1	1	1	1	1	1	1	1
2	495931	Seat belt, 2 in.	1	1	1	1	1	1	1	1	1	1	1	1	1	1	1	1
3	K44877	Washer, flat	4	4	4	4	4	4	4	4	4	4	4	4	4	4	4	4
4	K34791	Washer, lock	4	4	4	4	4	4	4	4	4	4	4	4	4	4	4	4
5	K33770	Nut	4	4	4	4	4	4	4	4	4	4	4	4	4	4	4	4
6	K20391	Bolt	2	2	2	2	2	2	2	2	2	2	2	2	2	2	2	2
7	K34808	Washer, lock	2	2	2	2	2	2	2	2	2	2	2	2	2	2	2	2
8	807167	Seat belt, 3 inch wide, retractable (includes hardware)	1	1	1	1	1	1	1	1	1	1	1	1	1	1	1	1

8 AA 482
TIER III

FRONT FENDERS, 100 IN. CAB

M30-2T	M30-4T	M30-2T H	M30-4T H
M40-2T	M40-4T	M40-2T H	M40-4T H
M50-2T	M50-4T	M50-2T H	M50-4T H
M30-2T L	M30-4T L	M30-2T H L	M30-4T H L
M40-2T L	M40-4T L	M40-2T H L	M40-4T H L
M50-2T L	M50-4T L	M50-2T H L	M50-4T H L

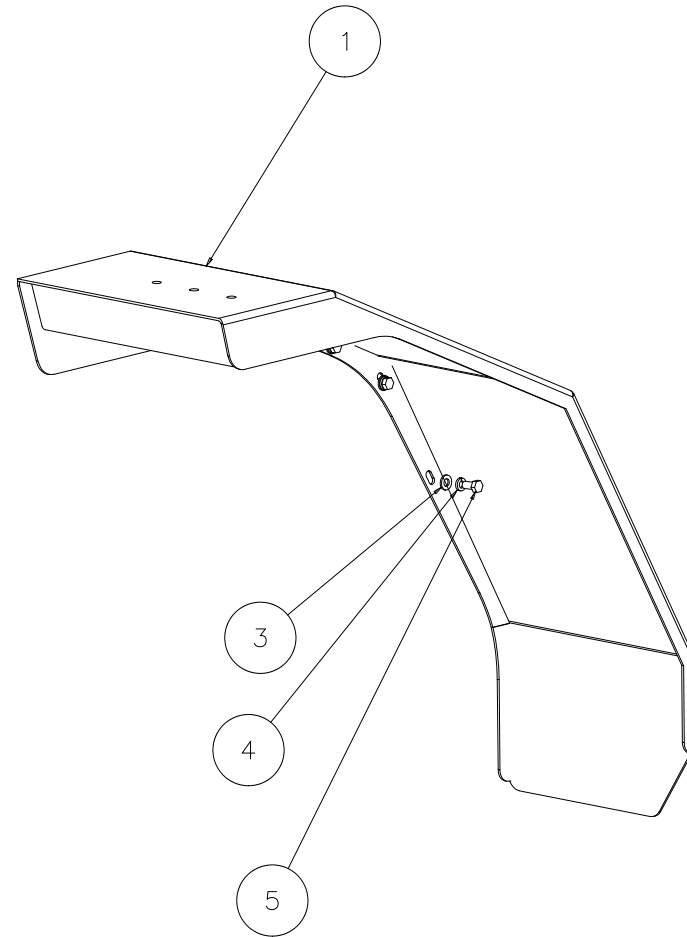
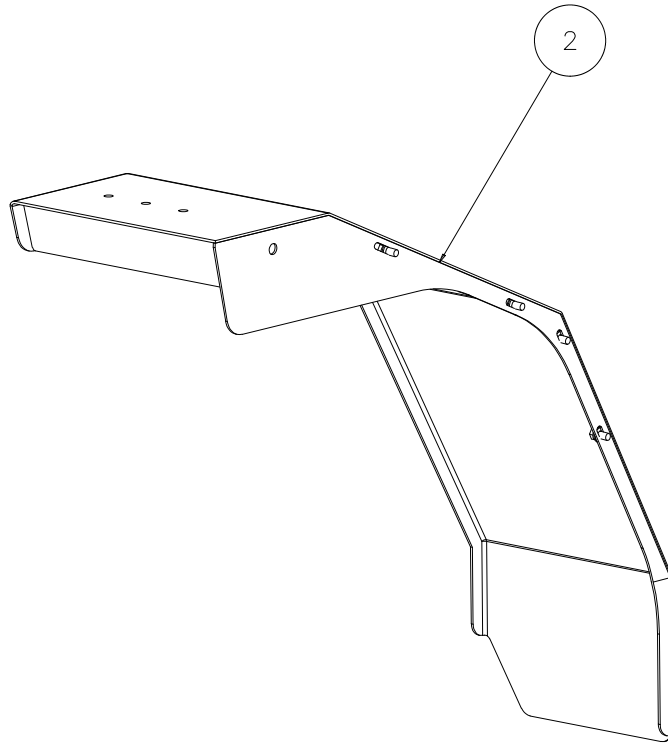

1	FRONT FENDERS, 100 IN. CAB			QUANTITY / MODEL												8 AA 482		
				M30-4T	M40-4T	M50-4T		M30-4T H	M40-4T H	M50-4T H		M30-4T L	M40-4T L	M50-4T L		M30-4T HL	M40-4T HL	M50-4T HL
ITEM	PART NO.	DESCRIPTION	M30-2T	M40-2T	M50-2T		M30-2T H	M40-2T H	M50-2T H		M30-2T L	M40-2T L	M50-2T L		M30-2T HL	M40-2T HL	M50-2T HL	
1	803499	Fender assembly, front LH, fully enclosed cab	1	1	1	1	1	1	1	1	1	1	1	1	1	1	1	
2	803506	Fender assembly, front RH, fully enclosed cab	1	1	1	1	1	1	1	1	1	1	1	1	1	1	1	
3	29437	Washer, flat	8	8	8	8	8	8	8	8	8	8	8	8	8	8	8	
4	42232	Washer, lock	8	8	8	8	8	8	8	8	8	8	8	8	8	8	8	
5	63727	Bolt	8	8	8	8	8	8	8	8	8	8	8	8	8	8	8	
6	807487	Fender assembly, front LH, open cab	1	1	1	1	1	1	1	1	1	1	1	1	1	1	1	
7	807489	Fender assembly, front RH, open cab	1	1	1	1	1	1	1	1	1	1	1	1	1	1	1	

47.00

8 AA 483
TIER III

FRONT FENDERS, 81 & 77 IN. CABS

M30-2T	M30-4T	M30-2T H	M30-4T H
M40-2T	M40-4T	M40-2T H	M40-4T H
M50-2T	M50-4T	M50-2T H	M50-4T H
M30-2T L	M30-4T L	M30-2T H L	M30-4T H L
M40-2T L	M40-4T L	M40-2T H L	M40-4T H L
M50-2T L	M50-4T L	M50-2T H L	M50-4T H L

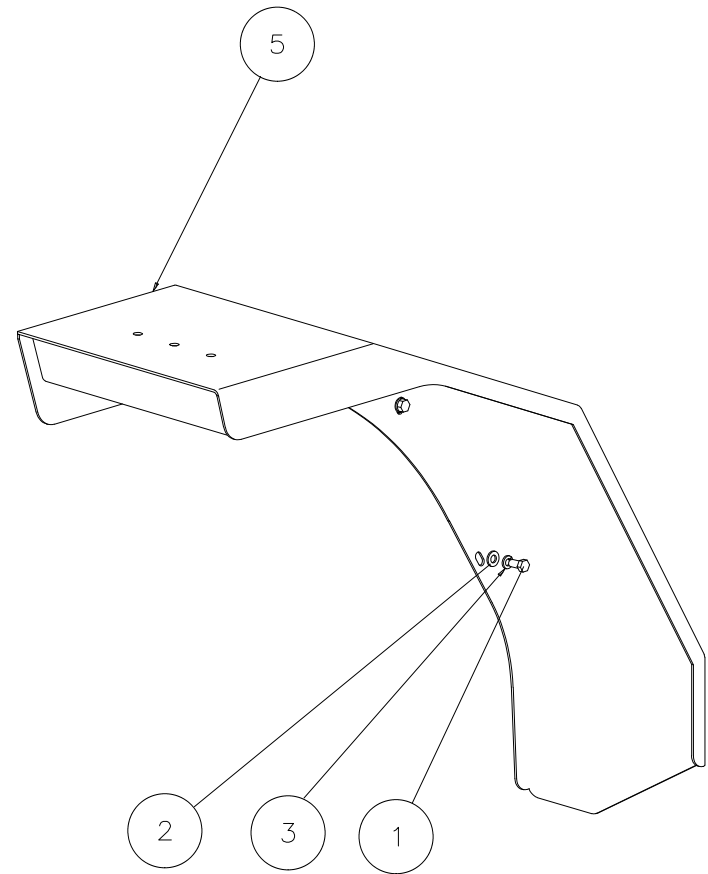
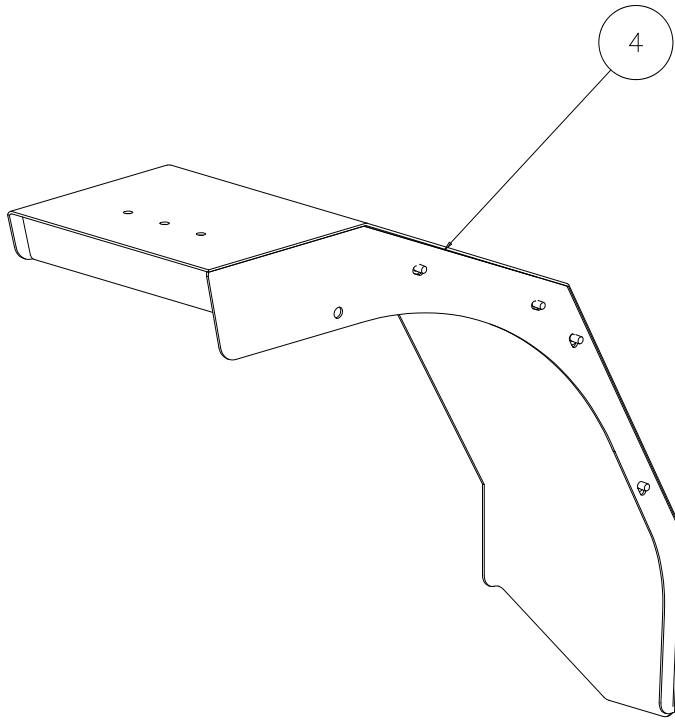

ITEM	PART NO.	DESCRIPTION	QUANTITY / MODEL												8 AA 483		
			M30-2T	M40-2T	M50-2T		M30-2T H	M40-2T H	M50-2T H		M30-2T L	M40-2T L	M50-2T L		M30-2T HL	M40-2T HL	M50-2T HL
1		FRONT FENDERS, 81 & 77 IN. CABS															
1	63727	Bolt	8	8	8	8	8	8	8	8	8	8	8	8	8	8	8
2	29437	Washer, flat	8	8	8	8	8	8	8	8	8	8	8	8	8	8	8
3	42232	Washer, lock	8	8	8	8	8	8	8	8	8	8	8	8	8	8	8
4	803458	Fender, front RH	1	1	1	1	1	1	1	1	1	1	1	1	1	1	1
5	803461	Fender, front LH	1	1	1	1	1	1	1	1	1	1	1	1	1	1	1

48.00

8 AA 665
TIER III

WINDSHIELD KIT, 100 IN. OPEN CAB (CAB 807376)

M30-2T	M30-4T	M30-2T H	M30-4T H
M40-2T	M40-4T	M40-2T H	M40-4T H
M50-2T	M50-4T	M50-2T H	M50-4T H
M30-2T L	M30-4T L	M30-2T H L	M30-4T H L
M40-2T L	M40-4T L	M40-2T H L	M40-4T H L
M50-2T L	M50-4T L	M50-2T H L	M50-4T H L

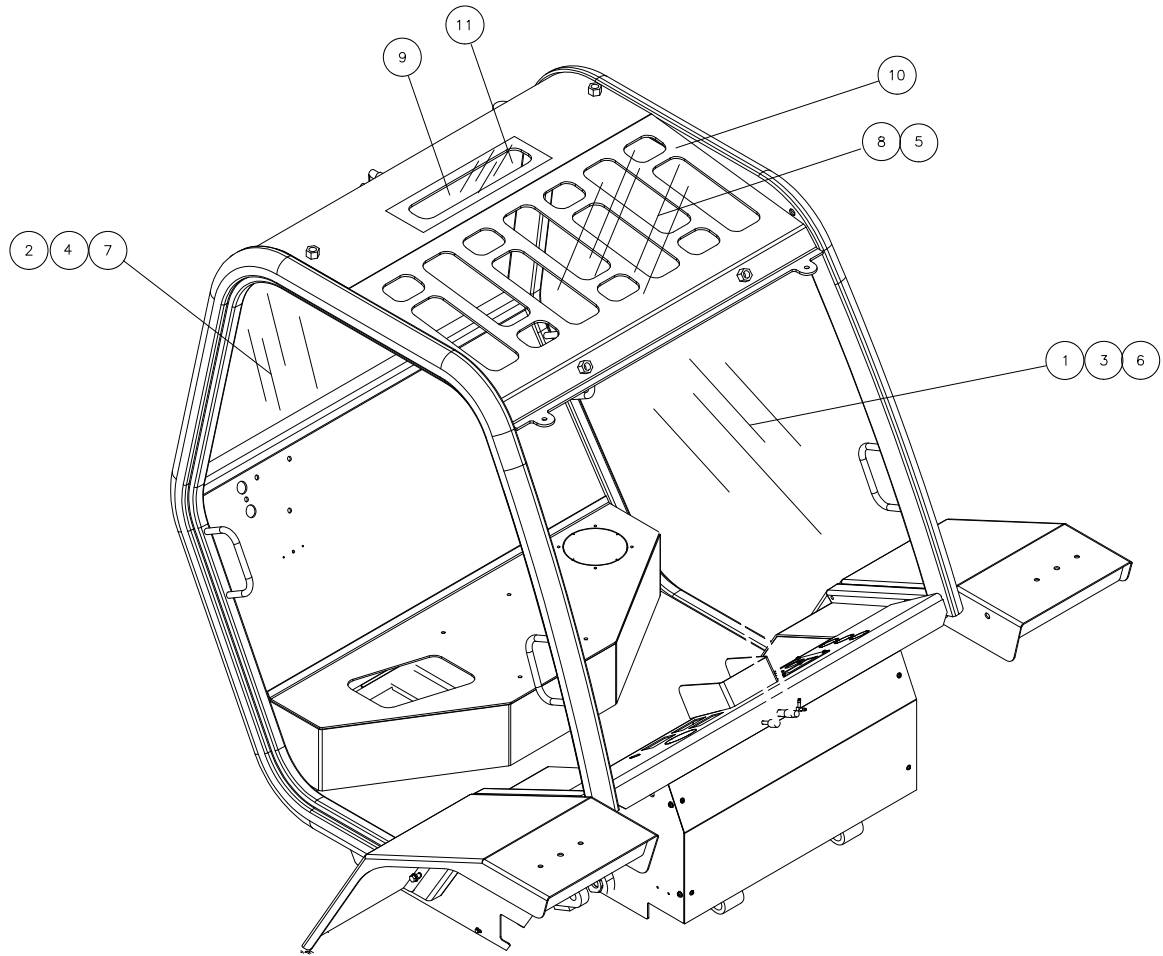

INSTALL TRIM-LOCK (ITEM 5) WITH BLACK URETHANE WINDSHIELD ADHESIVE.

1	WINDSHIELD KIT, 100 IN. OPEN CAB (CAB 807376)		QUANTITY / MODEL											8 AA 665			
			M30-4T	M40-4T	M50-4T		M30-4T H	M40-4T H	M50-4T H		M30-4T L	M40-4T L	M50-4T L		M30-4T HL	M40-4T HL	M50-4T HL
ITEM	PART NO.	DESCRIPTION	M30-2T	M40-2T	M50-2T		M30-2T H	M40-2T H	M50-2T H		M30-2T L	M40-2T L	M50-2T L		M30-2T HL	M40-2T HL	M50-2T HL
	807839	Windshield kit	1	1	1	1	1	1	1	1	1	1	1	1	1	1	1
1	803145	Glass plate, front	1	1	1	1	1	1	1	1	1	1	1	1	1	1	1
2	803143	Glass plate, rear	1	1	1	1	1	1	1	1	1	1	1	1	1	1	1
3	Z4056	Gasket, front, 140 in.	1	1	1	1	1	1	1	1	1	1	1	1	1	1	1
4	Z4056	Gasket, rear, 117 in.	1	1	1	1	1	1	1	1	1	1	1	1	1	1	1
5	Z4053	Trim-Lock, 122 in.	1	1	1	1	1	1	1	1	1	1	1	1	1	1	1
6*	803082	Panel, front	2	2	2	2	2	2	2	2	2	2	2	2	2	2	2
7*	803083	Panel, rear	1	1	1	1	1	1	1	1	1	1	1	1	1	1	1
8	807841	Glass plate, top front	1	1	1	1	1	1	1	1	1	1	1	1	1	1	1
9	807842	Glass plate, top rear	1	1	1	1	1	1	1	1	1	1	1	1	1	1	1
10	807875	Lexan, top front - requires black urethane adhesive	1	1	1	1	1	1	1	1	1	1	1	1	1	1	1
11	807876	Lexan, top rear - requires black urethane adhesive	1	1	1	1	1	1	1	1	1	1	1	1	1	1	1
		*For cabs without panels (welding required)															

8 AA 485
TIER III

WINDSHIELD KIT, 77 AND 81 IN. OPEN CAB
(HYDROSTATIC OR 4-SPEED)

M30-2T	M30-4T	M30-2T H	M30-4T H
M40-2T	M40-4T	M40-2T H	M40-4T H
M50-2T	M50-4T	M50-2T H	M50-4T H
M30-2T L	M30-4T L	M30-2T H L	M30-4T H L
M40-2T L	M40-4T L	M40-2T H L	M40-4T H L
M50-2T L	M50-4T L	M50-2T H L	M50-4T H L

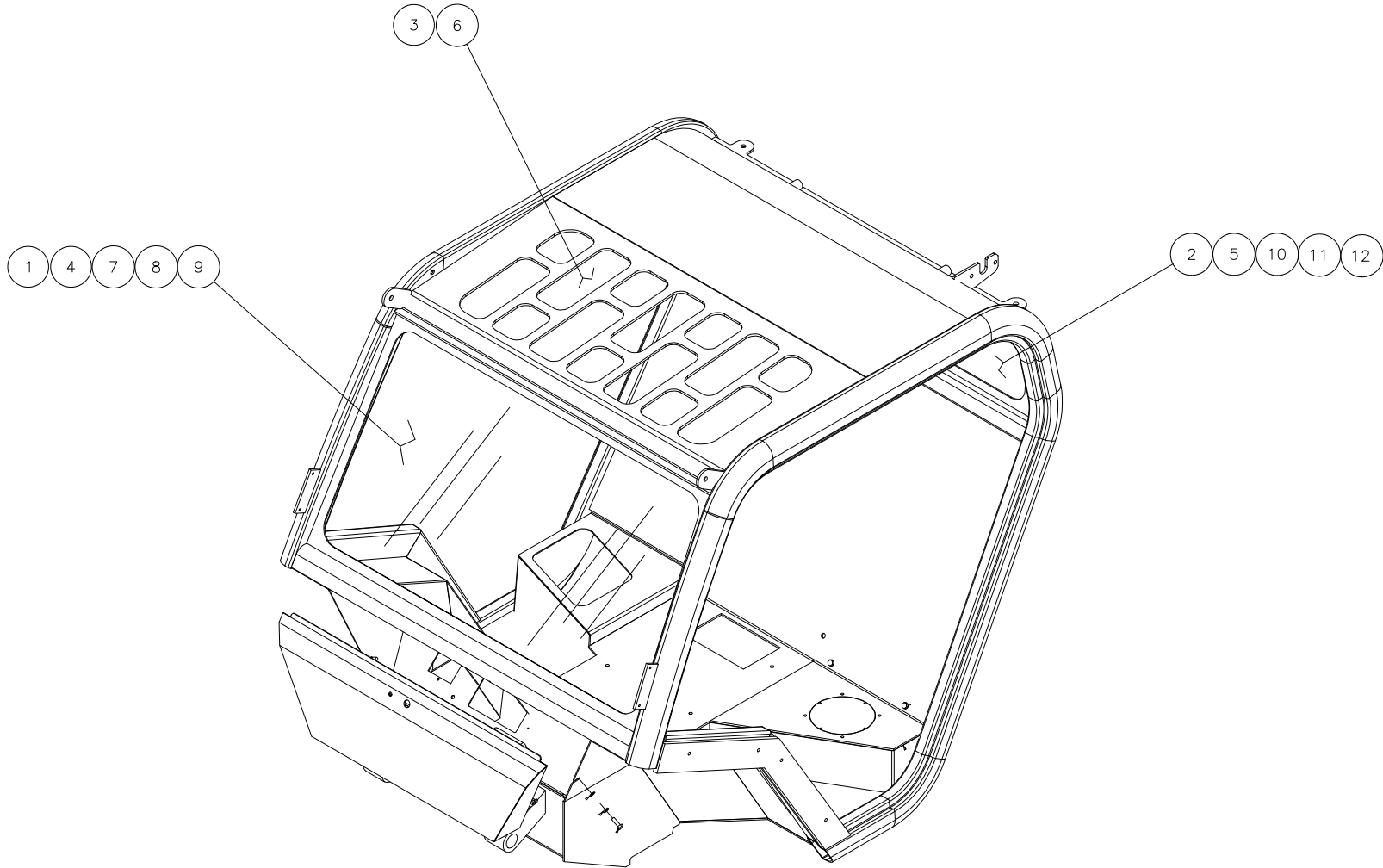

INSTALL TRIM-LOCK (ITEM 6) WITH BLACK URETHANE WINDSHIELD ADHESIVE.

1	WINDSHIELD KIT, 77 AND 81 IN. OPEN CAB (HYDROSTATIC OR 4-SPEED)		QUANTITY / MODEL												8 AA 485		
			M30-4T	M40-4T	M50-4T		M30-4T H	M40-4T H	M50-4T H		M30-4T L	M40-4T L	M50-4T L		M30-4T HL	M40-4T HL	M50-4T HL
ITEM	PART NO.	DESCRIPTION	M30-2T	M40-2T	M50-2T		M30-2T H	M40-2T H	M50-2T H		M30-2T L	M40-2T L	M50-2T L		M30-2T HL	M40-2T HL	M50-2T HL
	803138	Windshield kit	1	1	1	1	1	1	1	1	1	1	1	1	1	1	1
1	803144	Glass plate, front	1	1	1	1	1	1	1	1	1	1	1	1	1	1	1
2	803142	Glass plate, rear	1	1	1	1	1	1	1	1	1	1	1	1	1	1	1
3	803140	Glass plate, top	1	1	1	1	1	1	1	1	1	1	1	1	1	1	1
4	Z4056	Gasket, front, 117 in.	1	1	1	1	1	1	1	1	1	1	1	1	1	1	1
5	Z4056	Gasket, rear, 89 in.	1	1	1	1	1	1	1	1	1	1	1	1	1	1	1
6	Z4053	Trim-Lock, 115 in.	1	1	1	1	1	1	1	1	1	1	1	1	1	1	1
7*	803622	Frame, front upper	1	1	1	1	1	1	1	1	1	1	1	1	1	1	1
8*	803623	Frame, front side	1	1	1	1	1	1	1	1	1	1	1	1	1	1	1
9*	803621	Frame, front lower	1	1	1	1	1	1	1	1	1	1	1	1	1	1	1
10*	803625	Frame, rear upper	1	1	1	1	1	1	1	1	1	1	1	1	1	1	1
11*	803626	Frame, rear side	2	2	2	2	2	2	2	2	2	2	2	2	2	2	2
12*	803624	Frame, rear lower	1	1	1	1	1	1	1	1	1	1	1	1	1	1	1
		* For cabs without window framing (welding required)															

9 AA 322
TIER III

SIDE PANELS, REAR FENDERS, AND HOOD LIFT CYLINDER

M30-2T	M30-4T	M30-2T H	M30-4T H
M40-2T	M40-4T	M40-2T H	M40-4T H
M50-2T	M50-4T	M50-2T H	M50-4T H
M30-2T L	M30-4T L	M30-2T H L	M30-4T H L
M40-2T L	M40-4T L	M40-2T H L	M40-4T H L
M50-2T L	M50-4T L	M50-2T H L	M50-4T H L

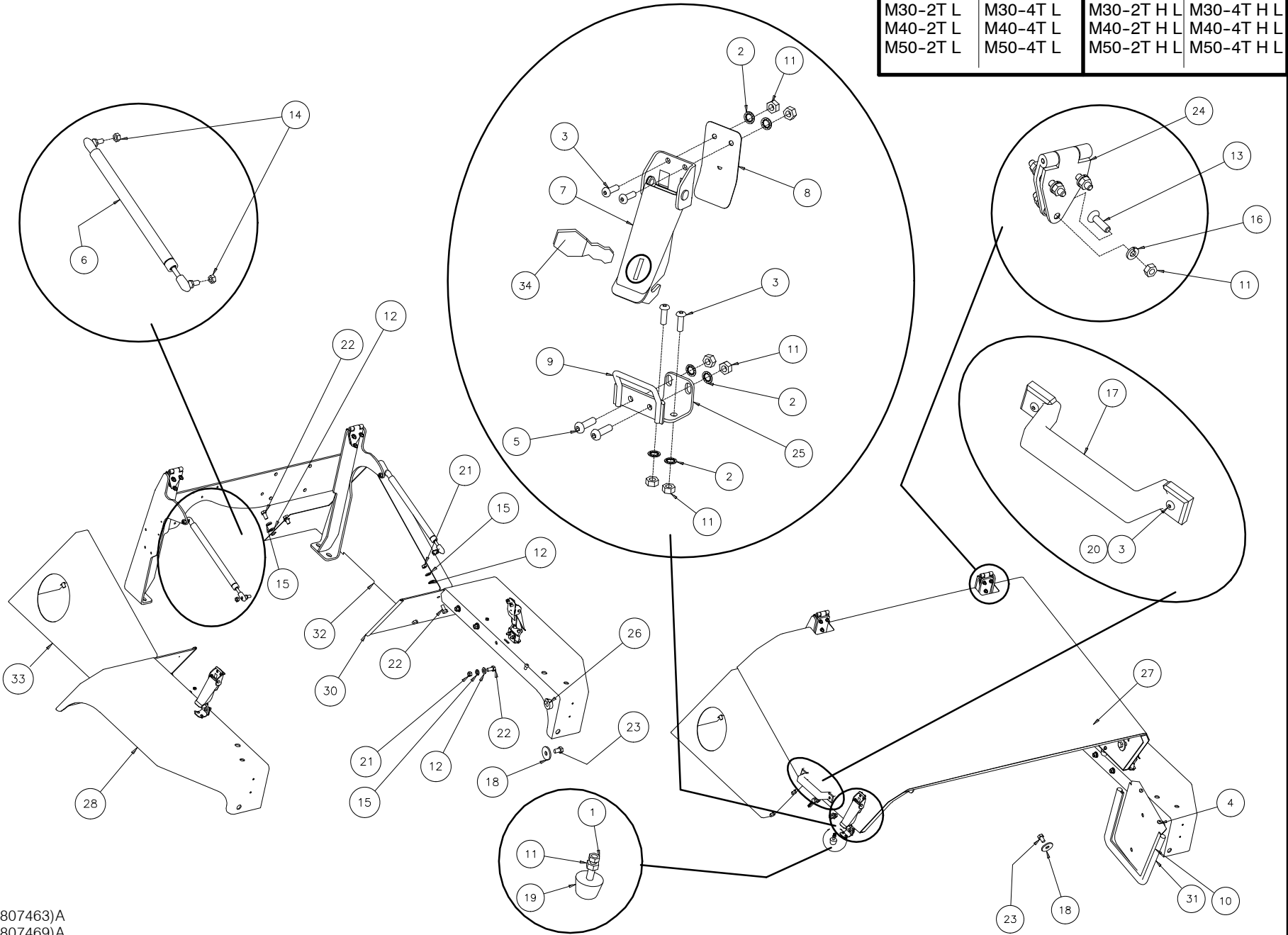

1	QUANTITY / MODEL												9 AA 322						
	SIDE PANELS, REAR FENDERS, AND HOOD LIFT CYLINDER																		
	ITEM	PART NO.	DESCRIPTION	M30-2T	M40-2T	M50-2T		M30-2T H	M40-2T H	M50-2T H		M30-2T L	M40-2T L	M50-2T L		M30-2T HL	M40-2T HL	M50-2T HL	
1	162229	Nut, lock	2	2	2	2	2	2	2	2	2	2	2	2	2	2	2	2	2
2	174132	Washer, lock	12	12	12	12	12	12	12	12	12	12	12	12	12	12	12	12	12
3	184036	Screw	8	8	8	8	8	8	8	8	8	8	8	8	8	8	8	8	8
4	202731	Screw	2	2	2	2	2	2	2	2	2	2	2	2	2	2	2	2	2
5	205275	Screw	4	4	4	4	4	4	4	4	4	4	4	4	4	4	4	4	4
6	209115	Air spring	2	2	2	2	2	2	2	2	2	2	2	2	2	2	2	2	2
7	223902	Latch, locking, w/ keys	2	2	2	2	2	2	2	2	2	2	2	2	2	2	2	2	2
8	223903	Spring	2	2	2	2	2	2	2	2	2	2	2	2	2	2	2	2	2
9	223904	Hook, latch	2	2	2	2	2	2	2	2	2	2	2	2	2	2	2	2	2
10	224345	Air baffle	1	1	1	1	1	1	1	1	1	1	1	1	1	1	1	1	1
11	25714	Nut	8	8	8	8	8	8	8	8	8	8	8	8	8	8	8	8	8
12	29437	Washer, flat	20	20	20	20	20	20	20	20	20	20	20	20	20	20	20	20	20
13	29441	Screw	6	6	6	6	6	6	6	6	6	6	6	6	6	6	6	6	6
14	3212	Nut	2	2	2	2	2	2	2	2	2	2	2	2	2	2	2	2	2
15	42232	Washer, lock	16	16	16	16	16	16	16	16	16	16	16	16	16	16	16	16	16
16	42316	Washer, lock	6	6	6	6	6	6	6	6	6	6	6	6	6	6	6	6	6
17	424186	Handle	2	2	2	2	2	2	2	2	2	2	2	2	2	2	2	2	2
18	44026	Washer, special	2	2	2	2	2	2	2	2	2	2	2	2	2	2	2	2	2
19	53501	Block, silent	2	2	2	2	2	2	2	2	2	2	2	2	2	2	2	2	2
20	54232	Nut	4	4	4	4	4	4	4	4	4	4	4	4	4	4	4	4	4
21	56354	Nut	12	12	12	12	12	12	12	12	12	12	12	12	12	12	12	12	12
22	5804	Bolt	6	6	6	6	6	6	6	6	6	6	6	6	6	6	6	6	6
23	63546	Bolt	1	1	1	1	1	1	1	1	1	1	1	1	1	1	1	1	1
24	79570	Hinge	2	2	2	2	2	2	2	2	2	2	2	2	2	2	2	2	2
25	802874	Bracket, hood latch	2	2	2	2	2	2	2	2	2	2	2	2	2	2	2	2	2
26	803079	Washer, special	2	2	2	2	2	2	2	2	2	2	2	2	2	2	2	2	2
27	803677	Hood	1	1	1	1	1	1	1	1	1	1	1	1	1	1	1	1	1

9 AA 323
TIER III

ENGINE COVER AND COUNTERWEIGHT COVER

M30-2T	M30-4T	M30-2T H	M30-4T H
M40-2T	M40-4T	M40-2T H	M40-4T H
M50-2T	M50-4T	M50-2T H	M50-4T H
M30-2T L	M30-4T L	M30-2T H L	M30-4T H L
M40-2T L	M40-4T L	M40-2T H L	M40-4T H L
M50-2T L	M50-4T L	M50-2T H L	M50-4T H L

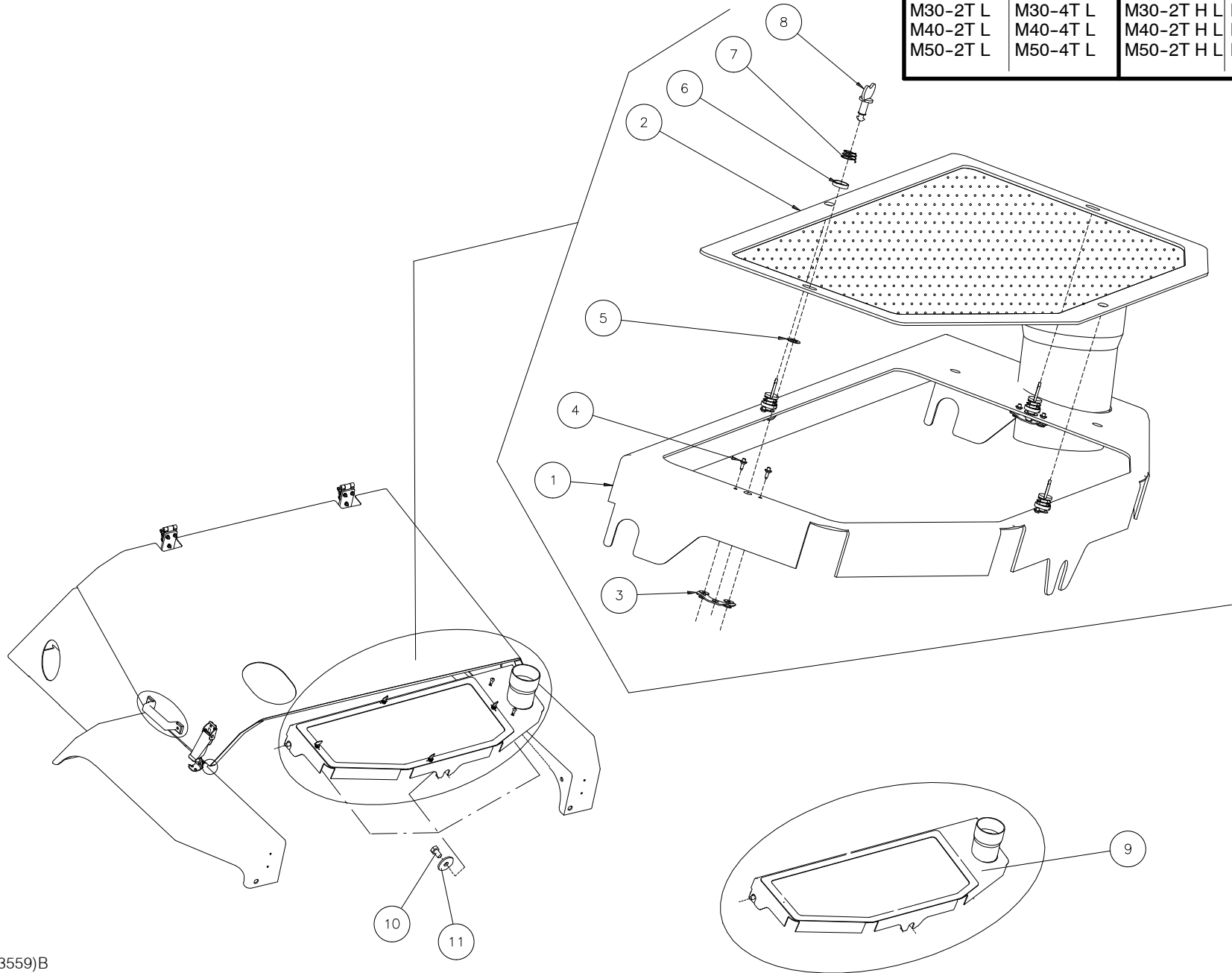

1	ENGINE COVER AND COUNTERWEIGHT COVER												9 AA 323					
	ITEM	PART NO.	DESCRIPTION	M30-2T	M40-2T	M50-2T		M30-2T H	M40-2T H	M50-2T H		M30-2T L	M40-2T L	M50-2T L		M30-2T HL	M40-2T HL	M50-2T HL
1	802769	Cover, counterweight	1	1	1	1	1	1	1	1	1	1	1	1	1	1	1	1
2	802884	Screen	1	1	1	1	1	1	1	1	1	1	1	1	1	1	1	1
3	802944	Receptacle, large	4	4	4	4	4	4	4	4	4	4	4	4	4	4	4	4
4	B254-2	Rivet	8	8	8	8	8	8	8	8	8	8	8	8	8	8	8	8
5	802943	Retainer, push-on	4	4	4	4	4	4	4	4	4	4	4	4	4	4	4	4
6	802945	Washer, cupped nylon	4	4	4	4	4	4	4	4	4	4	4	4	4	4	4	4
7	802946	Spring, stud ejector	4	4	4	4	4	4	4	4	4	4	4	4	4	4	4	4
8	802942	Stud, wing head recess	4	4	4	4	4	4	4	4	4	4	4	4	4	4	4	4
9	241607	Cover, counterweight, w/ permanent screen	1	1	1	1	1	1	1	1	1	1	1	1	1	1	1	1
10	63546	Bolt	3	3	3	3	3	3	3	3	3	3	3	3	3	3	3	3
11	44026	Washer	3	3	3	3	3	3	3	3	3	3	3	3	3	3	3	3

10 AA 633
TIER III

HYDRAULIC TANK ASSEMBLY, 4-SPEED TRANSMISSION

M30-2T	M30-4T		
M40-2T	M40-4T		
M50-2T	M50-4T		
M30-2T L	M30-4T L		
M40-2T L	M40-4T L		
M50-2T L	M50-4T L		

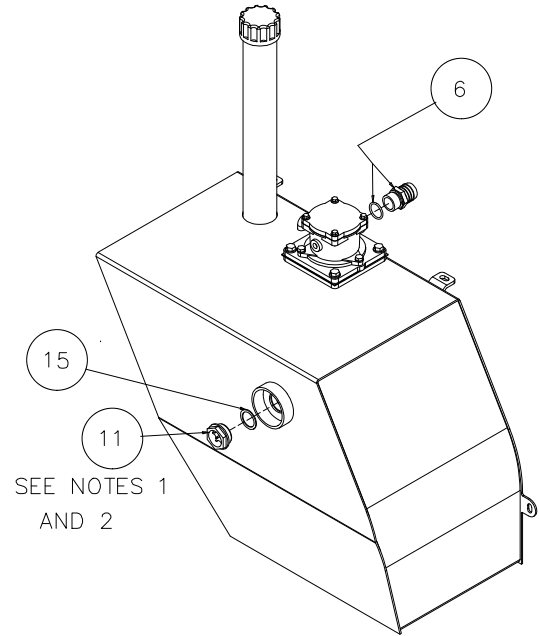
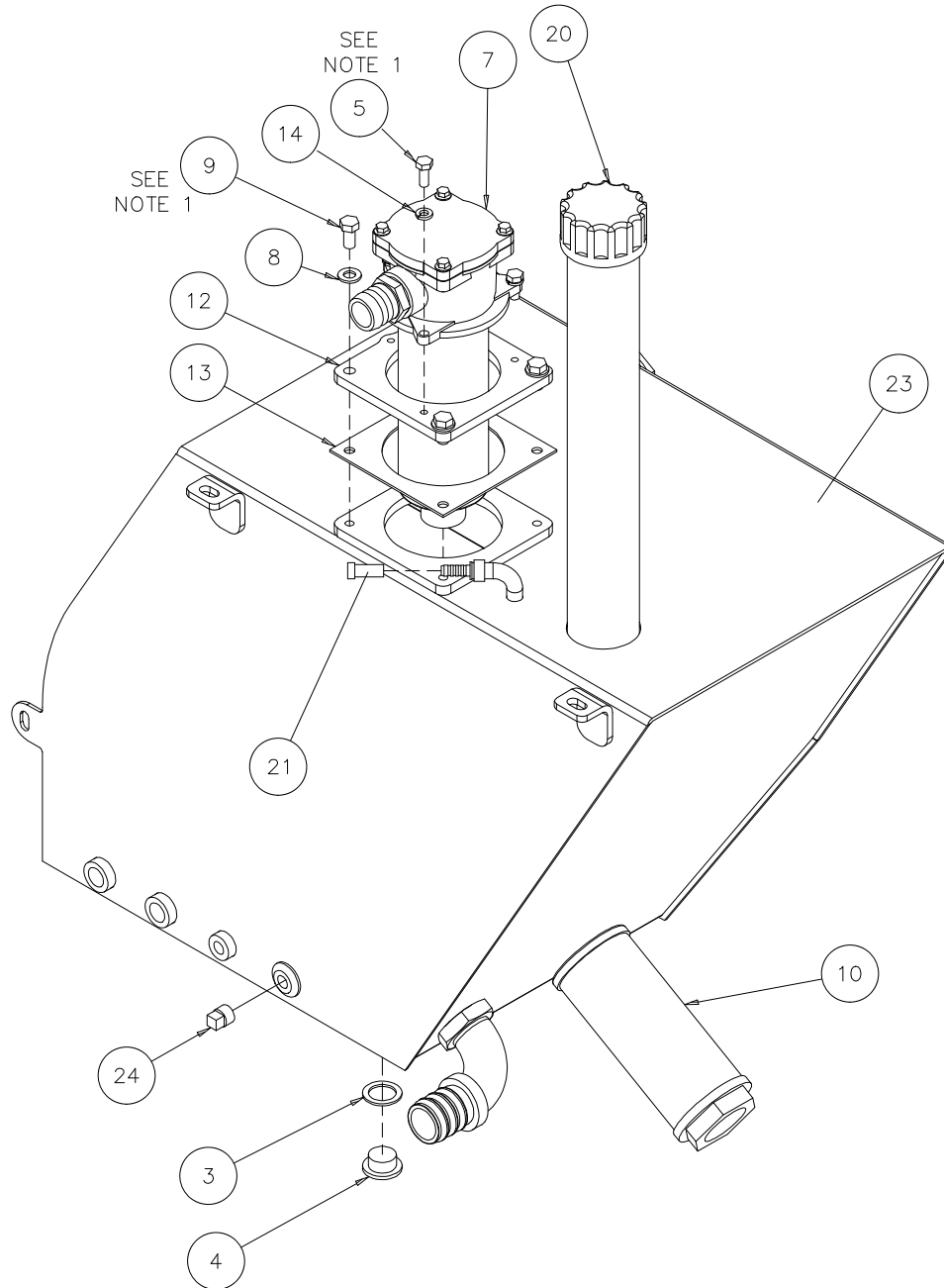

SEE NOTES 1 AND 2

NOTES:

1. APPLY LOCTITE 545 THREAD SEALER TO MALE THREAD.
2. DISCARD SEAL SUPPLIED WITH LEVEL GAUGE

			QUANTITY / MODEL										10 AA 633				
1 HYDRAULIC TANK ASSEMBLY, 4-SPEED TRANSMISSION			M30-4T	M40-4T	M50-4T						M30-4T L	M40-4T L	M50-4T L				
ITEM	PART NO.	DESCRIPTION	M30-2T	M40-2T	M50-2T						M30-2T L	M40-2T L	M50-2T L				
3	189536	Seal, drain plug	1	1	1	1					1	1	1	1			
4	189535	Drain plug	1	1	1	1					1	1	1	1			
5	42347	Bolt	3	3	3	3					3	3	3	3			
6	176864	Adapter, hose	1	1	1	1					1	1	1	1			
7	221172	Filter assembly, complete - see 10AA636	1	1	1	1					1	1	1	1			
8	29437	Washer, flat	4	4	4	4					4	4	4	4			
9	63727	Bolt	4	4	4	4					4	4	4	4			
10	424764	Strainer, hydraulic suction	1	1	1	1					1	1	1	1			
11	488236	Level gauge	1	1	1	1					1	1	1	1			
12	802263	Filter mounting plate	1	1	1	1					1	1	1	1			
13	802354	Gasket, filter adapter	1	1	1	1					1	1	1	1			
14	42325	Washer, lock	3	3	3	3					3	3	3	3			
15	K8-326	Seal	1	1	1	1					1	1	1	1			
20	425501	Filler cap, vented	1	1	1	1					1	1	1	1			
21	803039	Cap	1	1	1	1					1	1	1	1			
23	807431	Tank, hydraulic	1	1	1	1					1	1	1	1			
24	B114A3	Plug	1	1	1	1					1	1	1	1			

10 AA 634
TIER III

HYDRAULIC TANK ASSEMBLY, HYDROSTATIC TRANSMISSION

M30-2T H	M30-4T H
M40-2T H	M40-4T H
M50-2T H	M50-4T H

M30-2T H L	M30-4T H L
M40-2T H L	M40-4T H L
M50-2T H L	M50-4T H L

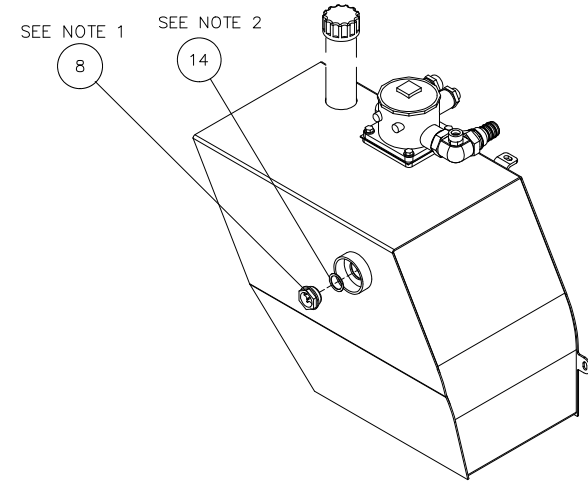
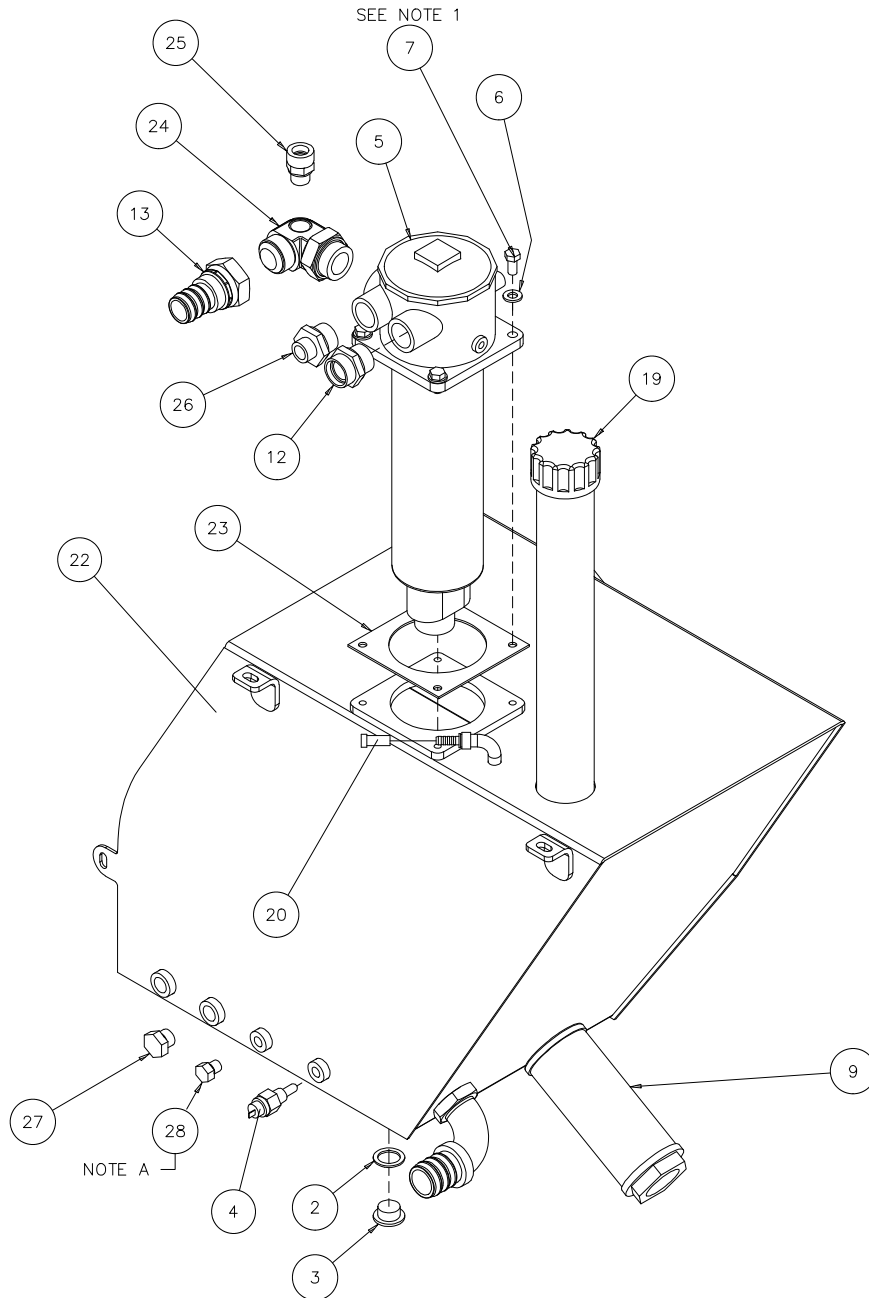

NOTES:

1. APPLY LOCTITE 545 THREAD SEALER TO MALE THREAD.
2. DISCARD SEAL SUPPLIED USE ITEM 14

NOTE A: REMOVE PLUG FOR DIFF LOCK OPTION.

			QUANTITY / MODEL								10 AA 634							
1 HYDRAULIC TANK ASSEMBLY, HYDROSTATIC TRANSMISSION							M30-4T H	M40-4T H	M50-4T H					M30-4T HL	M40-4T HL	M50-4T HL		
ITEM	PART NO.	DESCRIPTION					M30-2T H	M40-2T H	M50-2T H					M30-2T HL	M40-2T HL	M50-2T HL		
2	189536	Seal, drain plug					1	1	1	1					1	1	1	1
3	189535	Drain plug					1	1	1	1					1	1	1	1
4	425497	Temp switch					1	1	1	1					1	1	1	1
5	234292	Filter assembly, complete - see 10AA636					1	1	1	1					1	1	1	1
6	29437	Washer, flat					4	4	4	4					4	4	4	4
7	63727	Bolt					4	4	4	4					4	4	4	4
8	488236	Level gauge					1	1	1	1					1	1	1	1
9	424764	Strainer, hydraulic suction					1	1	1	1					1	1	1	1
12	803269	Connector					1	1	1	1					1	1	1	1
13	802451	Fitting					1	1	1	1					1	1	1	1
14	K8-326	Ring, back-up					1	1	1	1					1	1	1	1
19	425501	Filler cap, vented					1	1	1	1					1	1	1	1
20	803039	Cap					1	1	1	1					1	1	1	1
22	807431	Tank, hydraulic					1	1	1	1					1	1	1	1
23	802354	Gasket					1	1	1	1					1	1	1	1
24	803733	Elbow, tapped					1	1	1	1					1	1	1	1
25	213400	Adapter					1	1	1	1					1	1	1	1
26	803735	Connector					1	1	1	1					1	1	1	1
27	175743	Plug					1	1	1	1					1	1	1	1
28	803966	Plug					1	1	1	1					1	1	1	1

10 AA 635
Tier III

HYDRAULIC OIL COOLER, HYDROSTATIC
(OPTIONAL FOR TORQUE CONVERTER)

M 30-2T	M 30-4T	M 30-2TH	M 30-4TH
M 40-2T	M 40-4T	M 40-2TH	M 40-4TH
M 50-2T	M 50-4T	M 50-2TH	M 50-4TH
M 30-2TL	M 30-4TL	M 30-2THL	M 30-4THL
M 40-2TL	M 40-4TL	M 40-2THL	M 40-4THL
M 50-2TL	M 50-4TL	M 50-2THL	M 50-4THL

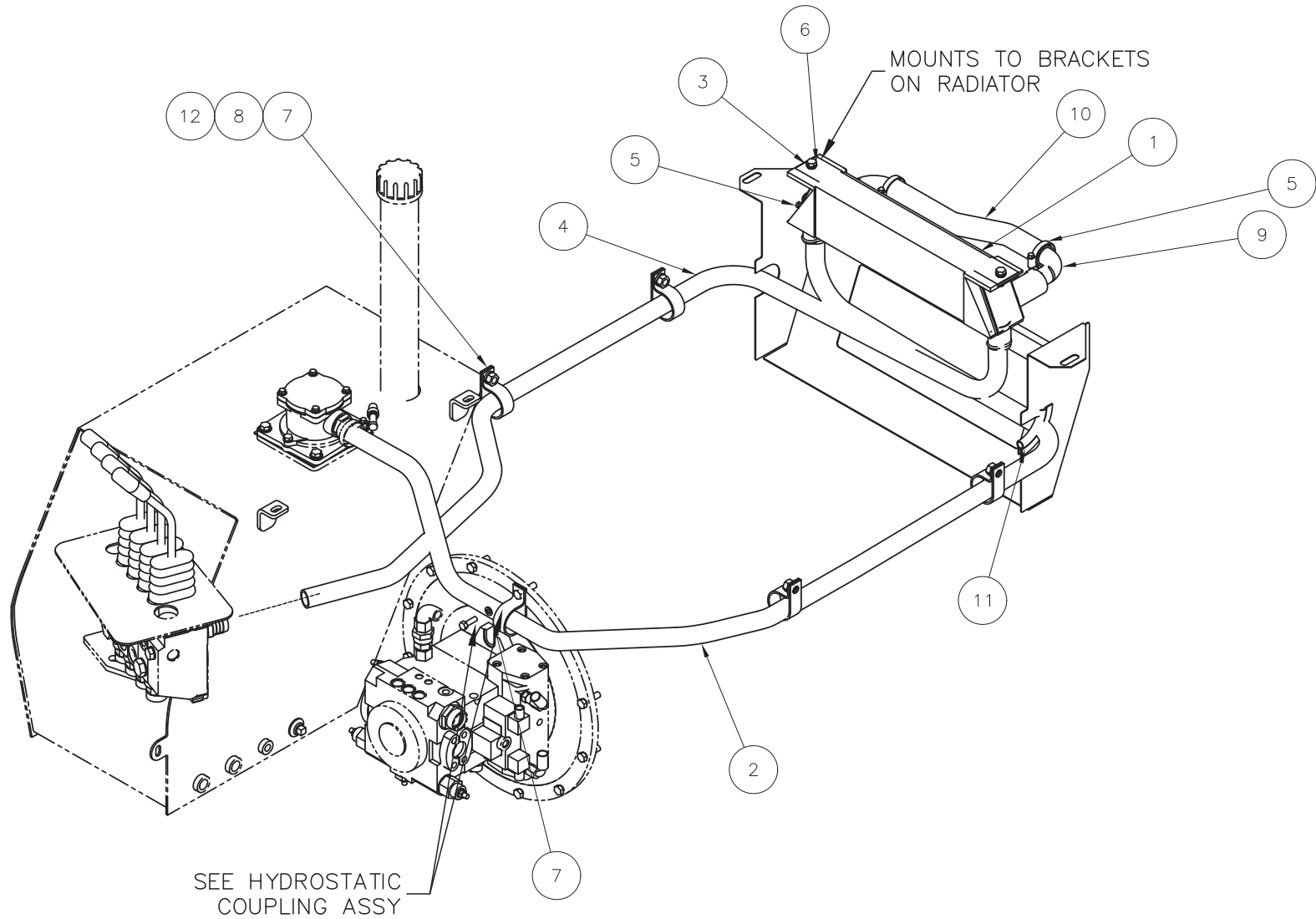

			QUANTITY / MODEL			10 AA 635		
			M 30-4 TH	M 40-4 TH	M 50-4 TH	M 30-4 THL	M 40-4 THL	M 50-4 THL
ITEM	PART NO.	DESCRIPTION	M 30-2 TH	M 40-2 TH	M 50-2 TH	M 30-2 THL	M 40-2 THL	M 50-2 THL
1		HYDRAULIC OIL COOLER, HYDRASTATIC (OPTIONAL FOR TORQUE CONVERTER)						
1	812481	OIL COOLER	1	1	1	1	1	1
2	813079	HOSE, ZL20	1	1	1	1	1	1
3	K34807	WASHER, 3/8 LOCK	6	6	6	6	6	6
4	813080	HOSE, ZL20	1	1	1	1	1	1
5	804776	CLAMP, T-BOLT BAND	4	4	4	4	4	4
6	K20388	BOLT, 3/8-16 X 1"	2	2	2	2	2	2
7	B3698-25	CLAMP 1.87 DIA	5	5	5	5	5	5
8	42231	WASHER, M12 LOCK	4	4	4	4	4	4
9	813009	ELBOW	2	2	2	2	2	2
10	813025	HOSE	1	1	1	1	1	1
11	Z4054-5"	WEATHERSTRIP, RUBBER	2	2	2	2	2	2
12	58548	NUT, M12-1.75 HEX	4	4	4	4	4	4

55.00

10 AA 636
TIER III

FILTER ASSEMBLIES, HYDRAULIC TANK

M30-2T	M30-4T	M30-2T H	M30-4T H
M40-2T	M40-4T	M40-2T H	M40-4T H
M50-2T	M50-4T	M50-2T H	M50-4T H
M30-2T L	M30-4T L	M30-2T H L	M30-4T H L
M40-2T L	M40-4T L	M40-2T H L	M40-4T H L
M50-2T L	M50-4T L	M50-2T H L	M50-4T H L

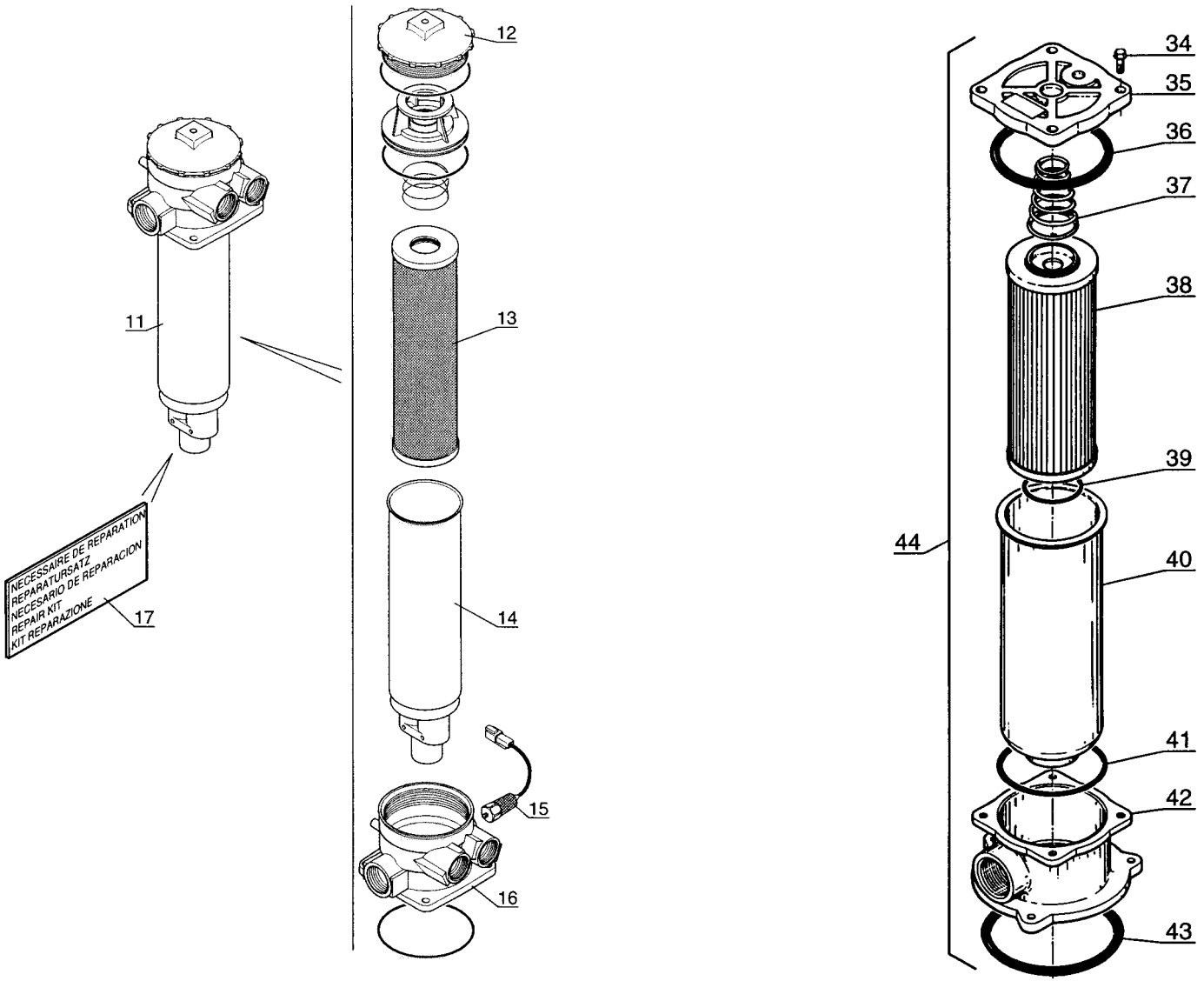

1	FILTER ASSEMBLIES, HYDRAULIC TANK		QUANTITY / MODEL												10 AA 636				
			M30-4T	M40-4T	M50-4T		M30-4T H	M40-4T H	M50-4T H		M30-4T L	M40-4T L	M50-4T L		M30-4T HL	M40-4T HL	M50-4T HL		
ITEM	PART NO.	DESCRIPTION	M30-2T	M40-2T	M50-2T		M30-2T H	M40-2T H	M50-2T H		M30-2T L	M40-2T L	M50-2T L		M30-2T HL	M40-2T HL	M50-2T HL		
11	234292	Hydraulic return oil filter, complete, hydrostatic					1	1	1	1					1	1	1	1	
12	602094	Cover					1	1	1	1					1	1	1	1	
13	602096	Filter cartridge					1	1	1	1					1	1	1	1	
14	602097	Tube					1	1	1	1					1	1	1	1	
15	602099	Switch, filter clogging					1	1	1	1					1	1	1	1	
16	602095	Body, filter return					1	1	1	1					1	1	1	1	
17	602098	Filter kit					1	1	1	1					1	1	1	1	
34	562461	Screw	4	4	4	4					4	4	4	4					
35	562086	Cover	1	1	1	1					1	1	1	1					
36	48384	O-ring	1	1	1	1					1	1	1	1					
37	562088	Spring	1	1	1	1					1	1	1	1					
38	221174	Filter cartridge	1	1	1	1					1	1	1	1					
39	562092	O-ring	1	1	1	1					1	1	1	1					
40	562095	Tube	1	1	1	1					1	1	1	1					
41	562090	Seal	1	1	1	1					1	1	1	1					
42	562089	Body, filter return	1	1	1	1					1	1	1	1					
43	562093	Seal	1	1	1	1					1	1	1	1					
44	221172	Hydraulic return oil filter, complete, 4-speed	1	1	1	1					1	1	1	1					

10 AE 736
TIER III

HYDRAULIC SYSTEM, PUMP AND CONTROLS

M30-2T	M30-4T	M30-2T H	M30-4T H
M40-2T	M40-4T	M40-2T H	M40-4T H
M50-2T	M50-4T	M50-2T H	M50-4T H
M30-2T L	M30-4T L	M30-2T H L	M30-4T H L
M40-2T L	M40-4T L	M40-2T H L	M40-4T H L
M50-2T L	M50-4T L	M50-2T H L	M50-4T H L

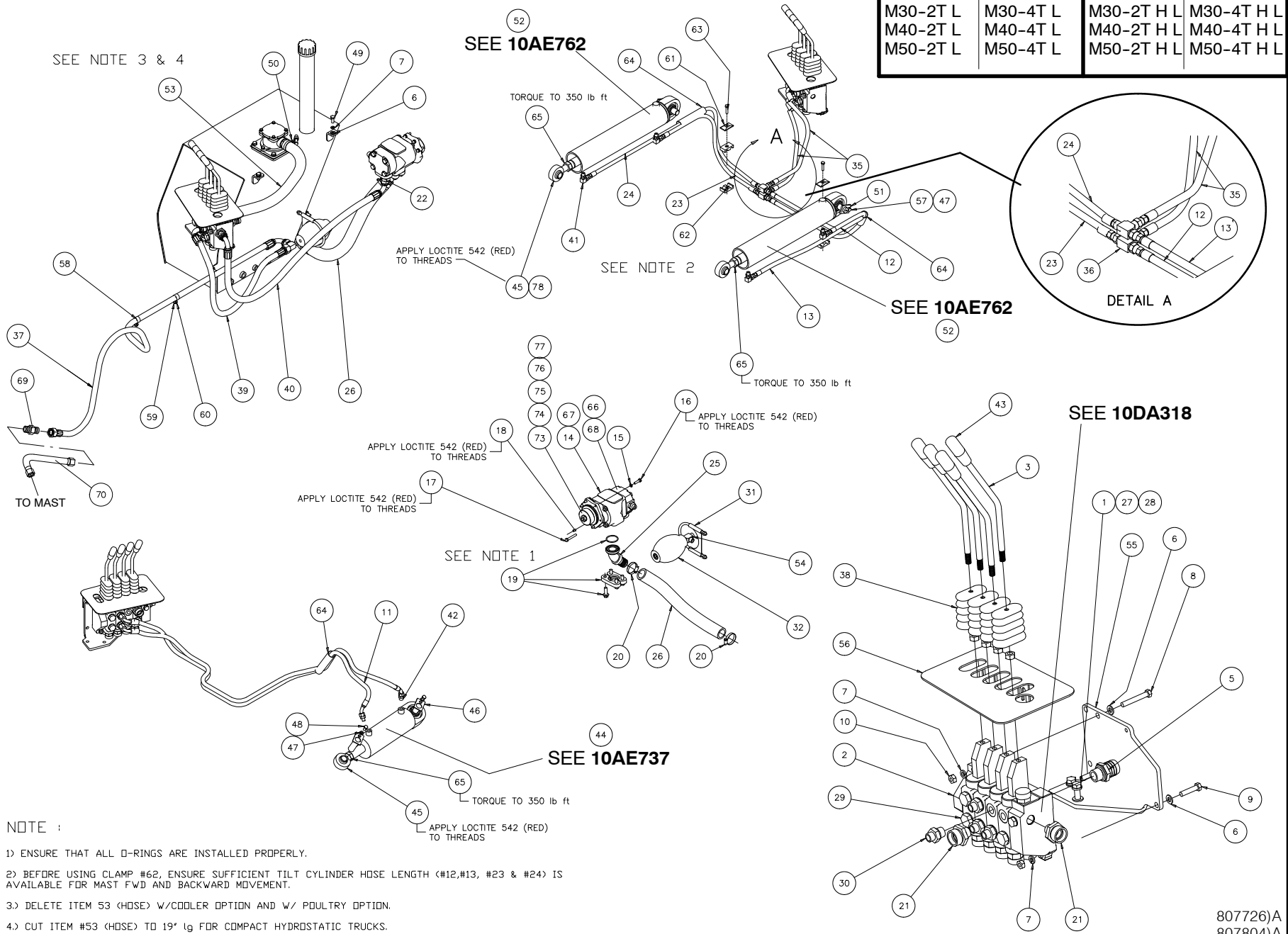

- NOTE :
- 1) ENSURE THAT ALL O-RINGS ARE INSTALLED PROPERLY.
 - 2) BEFORE USING CLAMP #62, ENSURE SUFFICIENT TILT CYLINDER HOSE LENGTH (#12,#13, #23 & #24) IS AVAILABLE FOR MAST FWD AND BACKWARD MOVEMENT.
 - 3) DELETE ITEM 53 (HOSE) W/COOLER OPTION AND W/ POULTRY OPTION.
 - 4) CUT ITEM #53 (HOSE) TO 19' L₉ FOR COMPACT HYDROSTATIC TRUCKS.

1	HYDRAULIC SYSTEM, PUMP AND CONTROLS		QUANTITY / MODEL												10 AE 736			
			M30-4T	M40-4T	M50-4T		M30-4T H	M40-4T H	M50-4T H		M30-4T L	M40-4T L	M50-4T L		M30-4T HL	M40-4T HL	M50-4T HL	
ITEM	PART NO.	DESCRIPTION	M30-2T	M40-2T	M50-2T		M30-2T H	M40-2T H	M50-2T H		M30-2T L	M40-2T L	M50-2T L		M30-2T HL	M40-2T HL	M50-2T HL	
1	63547	Bolt	2	2	2	2	2	2	2	2	2	2	2	2	2	2	2	2
2	209131	Valve assembly, 4 spool	1	1	1	1	1	1	1	1	1	1	1	1	1	1	1	1
3	801851	Lever, valve	4	4	4	4	4	4	4	4	4	4	4	4	4	4	4	4
4	58548	Nut	4	4	4	4	4	4	4	4	4	4	4	4	4	4	4	4
5	192093	Adapter	1	1	1	1	1	1	1	1	1	1	1	1	1	1	1	1
6	29437	Washer, flat	7	7	7	7	7	7	7	7	7	7	7	7	7	7	7	7
7	42232	Washer, lock	7	7	7	7	7	7	7	7	7	7	7	7	7	7	7	7
8	58538	Bolt	2	2	2	2	2	2	2	2	2	2	2	2	2	2	2	2
9	58536	Bolt	1	1	1	1	1	1	1	1	1	1	1	1	1	1	1	1
10	56354	Nut	3	3	3	3	3	3	3	3	3	3	3	3	3	3	3	3
11	803025	Hose assembly	2	2	2	2	2	2	2	2	2	2	2	2	2	2	2	2
12	807719	Hose assembly	1	1	1	1	1	1	1	1	1	1	1	1	1	1	1	1
13	807720	Hose assembly	1	1	1	1	1	1	1	1	1	1	1	1	1	1	1	1
14*	249256	Pump, hydraulic	1	1	1	1	1	1	1	1	1	1	1	1	1	1	1	1
15	42325	Washer, lock	4	4	4	4	4	4	4	4	4	4	4	4	4	4	4	4
16	63754	Bolt	4	4	4	4	4	4	4	4	4	4	4	4	4	4	4	4
17	61545	Bolt	1	1	1	1	1	1	1	1	1	1	1	1	1	1	1	1
18	73191	Screw	1	1	1	1	1	1	1	1	1	1	1	1	1	1	1	1
19	496830	Flange kit	1	1	1	1	1	1	1	1	1	1	1	1	1	1	1	1
20	177274	Clamp, hose	1	1	1	1	1	1	1	1	1	1	1	1	1	1	1	1
21	803031	Adapter	1	1	1	1	1	1	1	1	1	1	1	1	1	1	1	1
22	803032	Adapter	1	1	1	1	1	1	1	1	1	1	1	1	1	1	1	1
23	807716	Hose assembly	1	1	1	1	1	1	1	1	1	1	1	1	1	1	1	1
24	807717	Hose assembly	1	1	1	1	1	1	1	1	1	1	1	1	1	1	1	1
25	496829	Flange	1	1	1	1	1	1	1	1	1	1	1	1	1	1	1	1
26	802367	Hose, suction	1	1	1	1	1	1	1	1	1	1	1	1	1	1	1	1
27	61676	Washer, flat	2	2	2	2	2	2	2	2	2	2	2	2	2	2	2	2

change note

10 AE 737
TIER III

MAST SIDE-SHIFT CYLINDER ASSEMBLY

M30-2T	M30-4T	M30-2T H	M30-4T H
M40-2T	M40-4T	M40-2T H	M40-4T H
M50-2T	M50-4T	M50-2T H	M50-4T H
M30-2T L	M30-4T L	M30-2T H L	M30-4T H L
M40-2T L	M40-4T L	M40-2T H L	M40-4T H L
M50-2T L	M50-4T L	M50-2T H L	M50-4T H L

STAMPED ON BARREL: "803827" or "MD35006024S-B V10"

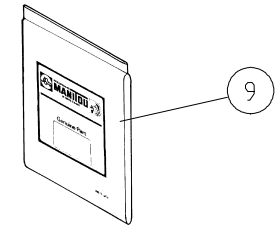
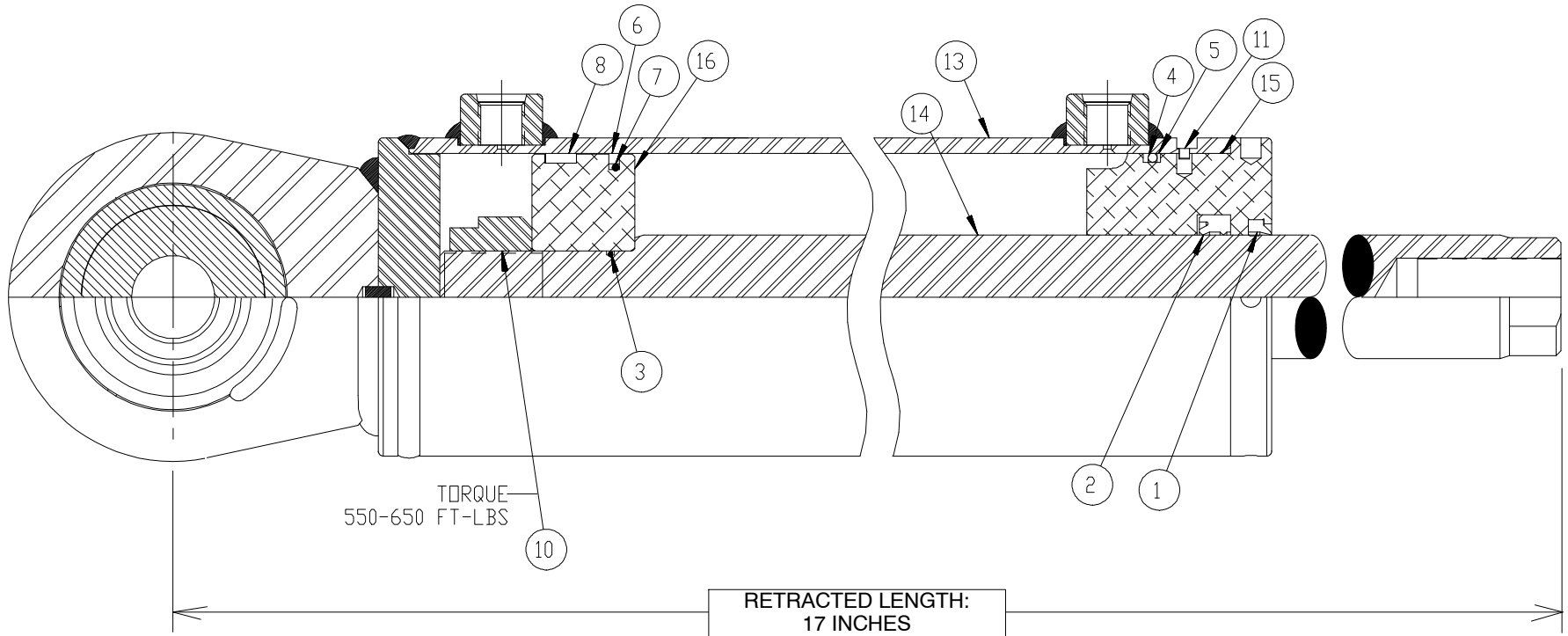

			QUANTITY / MODEL											10 AE 737			
			M30-4T	M40-4T	M50-4T		M30-4T H	M40-4T H	M50-4T H		M30-4T L	M40-4T L	M50-4T L		M30-4T HL	M40-4T HL	M50-4T HL
1	MAST SIDE-SHIFT CYLINDER ASSEMBLY		M30-2T	M40-2T	M50-2T		M30-2T H	M40-2T H	M50-2T H		M30-2T L	M40-2T L	M50-2T L		M30-2T HL	M40-2T HL	M50-2T HL
ITEM	PART NO.	DESCRIPTION	M30-2T	M40-2T	M50-2T		M30-2T H	M40-2T H	M50-2T H		M30-2T L	M40-2T L	M50-2T L		M30-2T HL	M40-2T HL	M50-2T HL
	803827	Side Shift Cylinder Assembly	1	1	1	1	1	1	1	1	1	1	1	1	1	1	1
1*	803818	Wiper	1	1	1	1	1	1	1	1	1	1	1	1	1	1	1
2*	803817	Seal, rod	1	1	1	1	1	1	1	1	1	1	1	1	1	1	1
3*	803820	O-Ring	1	1	1	1	1	1	1	1	1	1	1	1	1	1	1
4*	803821	O-Ring	1	1	1	1	1	1	1	1	1	1	1	1	1	1	1
5*	803822	Back-up Ring	1	1	1	1	1	1	1	1	1	1	1	1	1	1	1
6*	803823	Cap seal	1	1	1	1	1	1	1	1	1	1	1	1	1	1	1
7*	803824	O-Ring	1	1	1	1	1	1	1	1	1	1	1	1	1	1	1
8	803825	Wear ring	1	1	1	1	1	1	1	1	1	1	1	1	1	1	1
9	803826	Seal Kit	1	1	1	1	1	1	1	1	1	1	1	1	1	1	1
10	803841	Locknut	1	1	1	1	1	1	1	1	1	1	1	1	1	1	1
11	803840	Retaining ring	1	1	1	1	1	1	1	1	1	1	1	1	1	1	1
13	803845	Barrel, Side Shift	1	1	1	1	1	1	1	1	1	1	1	1	1	1	1
14	803844	Rod, Side Shift Cylinder	1	1	1	1	1	1	1	1	1	1	1	1	1	1	1
15	803843	Head, side shift cylinder	1	1	1	1	1	1	1	1	1	1	1	1	1	1	1
16	803842	Piston, side shift cylinder	1	1	1	1	1	1	1	1	1	1	1	1	1	1	1
		* Included in Seal Kit (Item 9).															

10 AE 762

TIER III

MAST TILT CYLINDER ASSEMBLY

M30-2T	M30-4T	M30-2T H	M30-4T H
M40-2T	M40-4T	M40-2T H	M40-4T H
M50-2T	M50-4T	M50-2T H	M50-4T H
M30-2T L	M30-4T L	M30-2T H L	M30-4T H L
M40-2T L	M40-4T L	M40-2T H L	M40-4T H L
M50-2T L	M50-4T L	M50-2T H L	M50-4T H L

STAMPED ON THE BARREL: "AM&H"

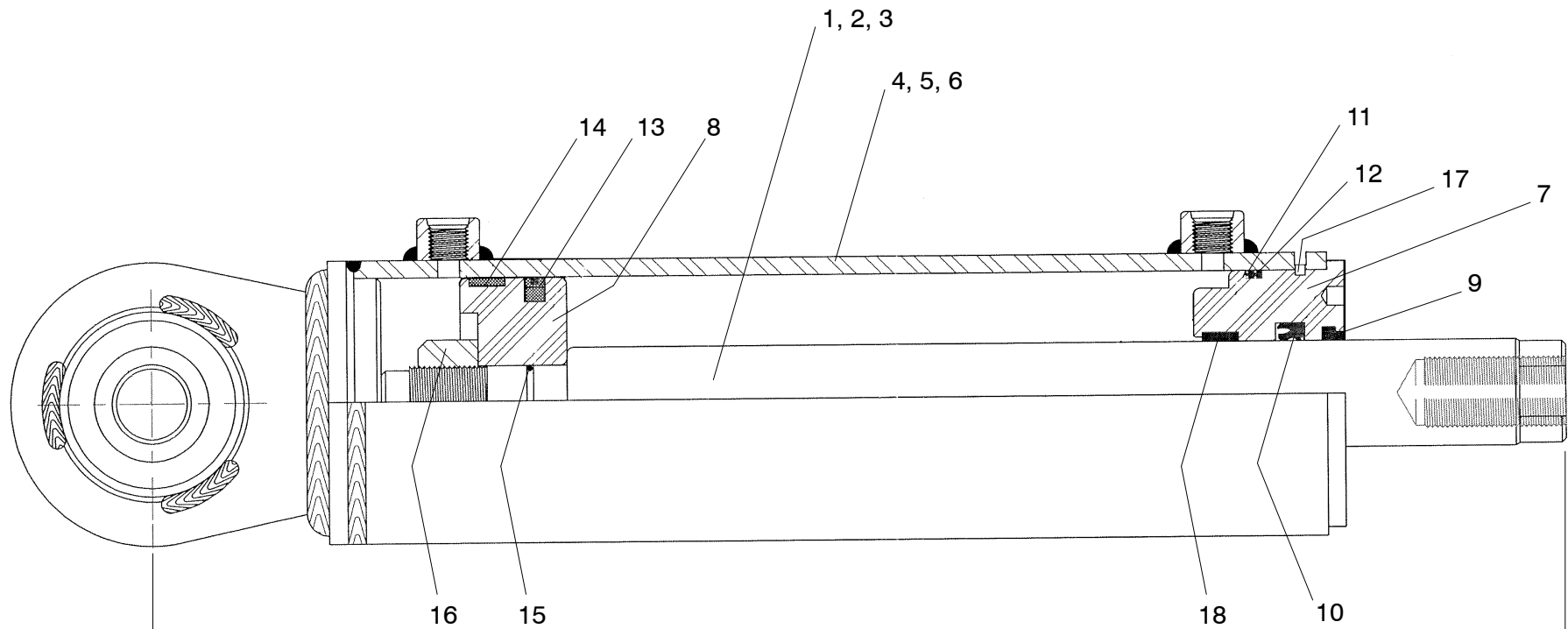

RETRACTED LENGTH:
Item 21) 803470-1) 21.88 INCHES
Item 22) 803470-2) 23.50 INCHES
Item 23) 807815) 24.25 INCHES

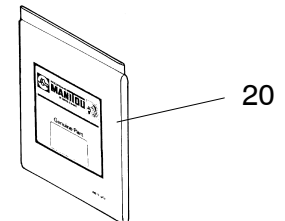

			QUANTITY / MODEL									10 AE 762						
			M30-4T	M40-4T	M50-4T		M30-4T H	M40-4T H	M50-4T H		M30-4T L	M40-4T L	M50-4T L		M30-4T HL	M40-4T HL	M50-4T HL	
1	MAST TILT CYLINDER ASSEMBLY																	
ITEM	PART NO.	DESCRIPTION	M30-2T	M40-2T	M50-2T		M30-2T H	M40-2T H	M50-2T H		M30-2T L	M40-2T L	M50-2T L		M30-2T HL	M40-2T HL	M50-2T HL	
1	806883	Rod, Tilt Cylinder, 20°/15° Tilt	1	1	1	1	1	1	1	1	1	1	1	1	1	1	1	1
2	806885	Rod, Tilt Cylinder, 20°/10° Tilt	1	1	1	1	1	1	1	1	1	1	1	1	1	1	1	1
3	809840	Rod, Tilt Cylinder, 45°/10° Tilt	1	1	1	1	1	1	1	1	1	1	1	1	1	1	1	1
4	806884	Barrel, Tilt Cylinder, 20°/15° Tilt	1	1	1	1	1	1	1	1	1	1	1	1	1	1	1	1
5	807150	Barrel, Tilt Cylinder, 20°/10° Tilt	1	1	1	1	1	1	1	1	1	1	1	1	1	1	1	1
6	809841	Barrel, Tilt Cylinder, 45°/10° Tilt	1	1	1	1	1	1	1	1	1	1	1	1	1	1	1	1
7	806887	Gland	1	1	1	1	1	1	1	1	1	1	1	1	1	1	1	1
8	806888	Piston	1	1	1	1	1	1	1	1	1	1	1	1	1	1	1	1
9*	806889	Wiper, rod	1	1	1	1	1	1	1	1	1	1	1	1	1	1	1	1
10*	806890	Seal, rod	1	1	1	1	1	1	1	1	1	1	1	1	1	1	1	1
11*	806891	O-Ring	1	1	1	1	1	1	1	1	1	1	1	1	1	1	1	1
12*	806892	Back-up Ring	1	1	1	1	1	1	1	1	1	1	1	1	1	1	1	1
13*	806893	Seal, piston	1	1	1	1	1	1	1	1	1	1	1	1	1	1	1	1
14	806894	Wear ring	1	1	1	1	1	1	1	1	1	1	1	1	1	1	1	1
15*	806895	O-Ring	1	1	1	1	1	1	1	1	1	1	1	1	1	1	1	1
16	806896	Locknut	1	1	1	1	1	1	1	1	1	1	1	1	1	1	1	1
17	806897	Lockwire	1	1	1	1	1	1	1	1	1	1	1	1	1	1	1	1
18	806898	Wear ring	1	1	1	1	1	1	1	1	1	1	1	1	1	1	1	1
20	803470KIT	Seal Kit (for Items 21 or 22)	1	1	1	1	1	1	1	1	1	1	1	1	1	1	1	1
20	807815KIT	Seal Kit (for Item 23)	1	1	1	1	1	1	1	1	1	1	1	1	1	1	1	1
21**	803470-1	Tilt Cylinder Assembly, 20°/15° Tilt (Stamped AM&H)	2	2	2	2	2	2	2	2	2	2	2	2	2	2	2	2
22**	803470-2	Tilt Cylinder Assembly, 20°/10° Tilt (Stamped AM&H)	2	2	2	2	2	2	2	2	2	2	2	2	2	2	2	2
23**	807815	Tilt Cylinder Assembly, 45°/10° Tilt (Stamped AM&H)	2	2	2	2	2	2	2	2	2	2	2	2	2	2	2	2

* Items included in Seal Kit (Item 20).

** Measure RETRACTED LENGTH to determine Cylinder Assembly Part Number.

10 AF 592
TIER III

HYDRAULIC DIFFERENTIAL LOCKING ASSEMBLY OPTION

M30-2T	M30-4T	M30-2T H	M30-4T H
M40-2T	M40-4T	M40-2T H	M40-4T H
M50-2T	M50-4T	M50-2T H	M50-4T H
M30-2T L	M30-4T L	M30-2T H L	M30-4T H L
M40-2T L	M40-4T L	M40-2T H L	M40-4T H L
M50-2T L	M50-4T L	M50-2T H L	M50-4T H L

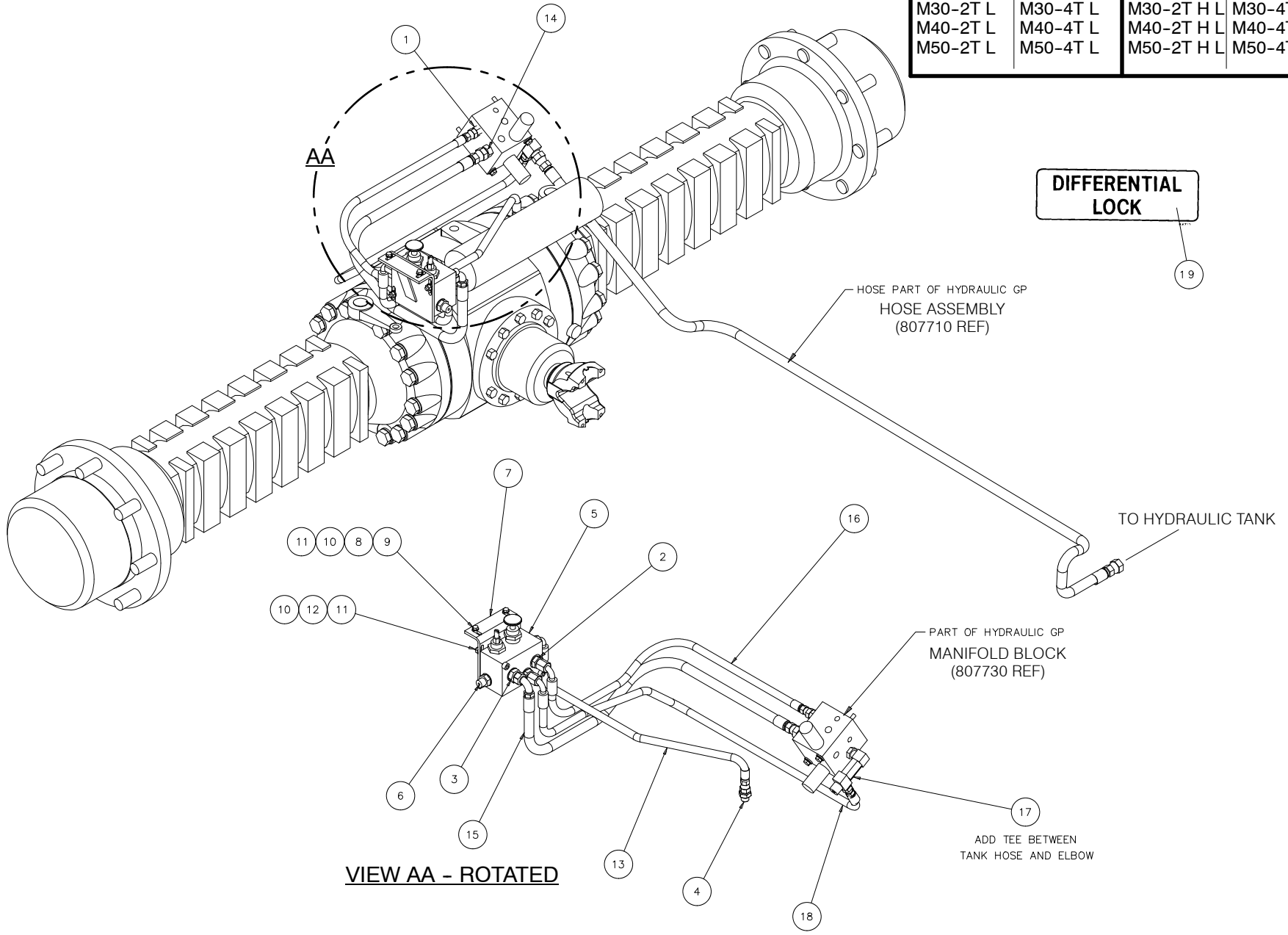

VIEW AA - ROTATED

1	HYDRAULIC DIFFERENTIAL LOCKING ASSEMBLY		QUANTITY / MODEL												10 AF 592		
			M30-4T	M40-4T	M50-4T		M30-4T H	M40-4T H	M50-4T H		M30-4T L	M40-4T L	M50-4T L		M30-4T HL	M40-4T HL	M50-4T HL
ITEM	PART NO.	DESCRIPTION	M30-2T	M40-2T	M50-2T		M30-2T H	M40-2T H	M50-2T H		M30-2T L	M40-2T L	M50-2T L		M30-2T HL	M40-2T HL	M50-2T HL
1	806372	Connector	1	1	1	1	1	1	1	1	1	1	1	1	1	1	1
2	803196	Connector	3	3	3	3	3	3	3	3	3	3	3	3	3	3	3
3	803177	Connector	1	1	1	1	1	1	1	1	1	1	1	1	1	1	1
4	803182	Connector	1	1	1	1	1	1	1	1	1	1	1	1	1	1	1
5	240077	Valve	1	1	1	1	1	1	1	1	1	1	1	1	1	1	1
6	72339	Fitting, pressure test	1	1	1	1	1	1	1	1	1	1	1	1	1	1	1
7	802983	Bracket, valve mount	1	1	1	1	1	1	1	1	1	1	1	1	1	1	1
8	174132	Washer, lock	2	2	2	2	2	2	2	2	2	2	2	2	2	2	2
9	25713	Bolt	2	2	2	2	2	2	2	2	2	2	2	2	2	2	2
10	42316	Washer, lock	4	4	4	4	4	4	4	4	4	4	4	4	4	4	4
11	25714	Nut	4	4	4	4	4	4	4	4	4	4	4	4	4	4	4
12	178696	Bolt	2	2	2	2	2	2	2	2	2	2	2	2	2	2	2
13	803020	Hose assembly	1	1	1	1	1	1	1	1	1	1	1	1	1	1	1
14	R18147-3	Connector	1	1	1	1	1	1	1	1	1	1	1	1	1	1	1
15	807701	Hose assembly, DLP to P	1	1	1	1	1	1	1	1	1	1	1	1	1	1	1
16	807712	Hose assembly, DLLS to LS	1	1	1	1	1	1	1	1	1	1	1	1	1	1	1
17	800554	Tee	1	1	1	1	1	1	1	1	1	1	1	1	1	1	1
18	807707	Hose assembly	1	1	1	1	1	1	1	1	1	1	1	1	1	1	1

10 BA 302
TIER III

STEERING HYDRAULICS, 2WD AND 4WD

M30-2T	M30-4T	M30-2T H	M30-4T H
M40-2T	M40-4T	M40-2T H	M40-4T H
M50-2T	M50-4T	M50-2T H	M50-4T H
M30-2T L	M30-4T L	M30-2T H L	M30-4T H L
M40-2T L	M40-4T L	M40-2T H L	M40-4T H L
M50-2T L	M50-4T L	M50-2T H L	M50-4T H L

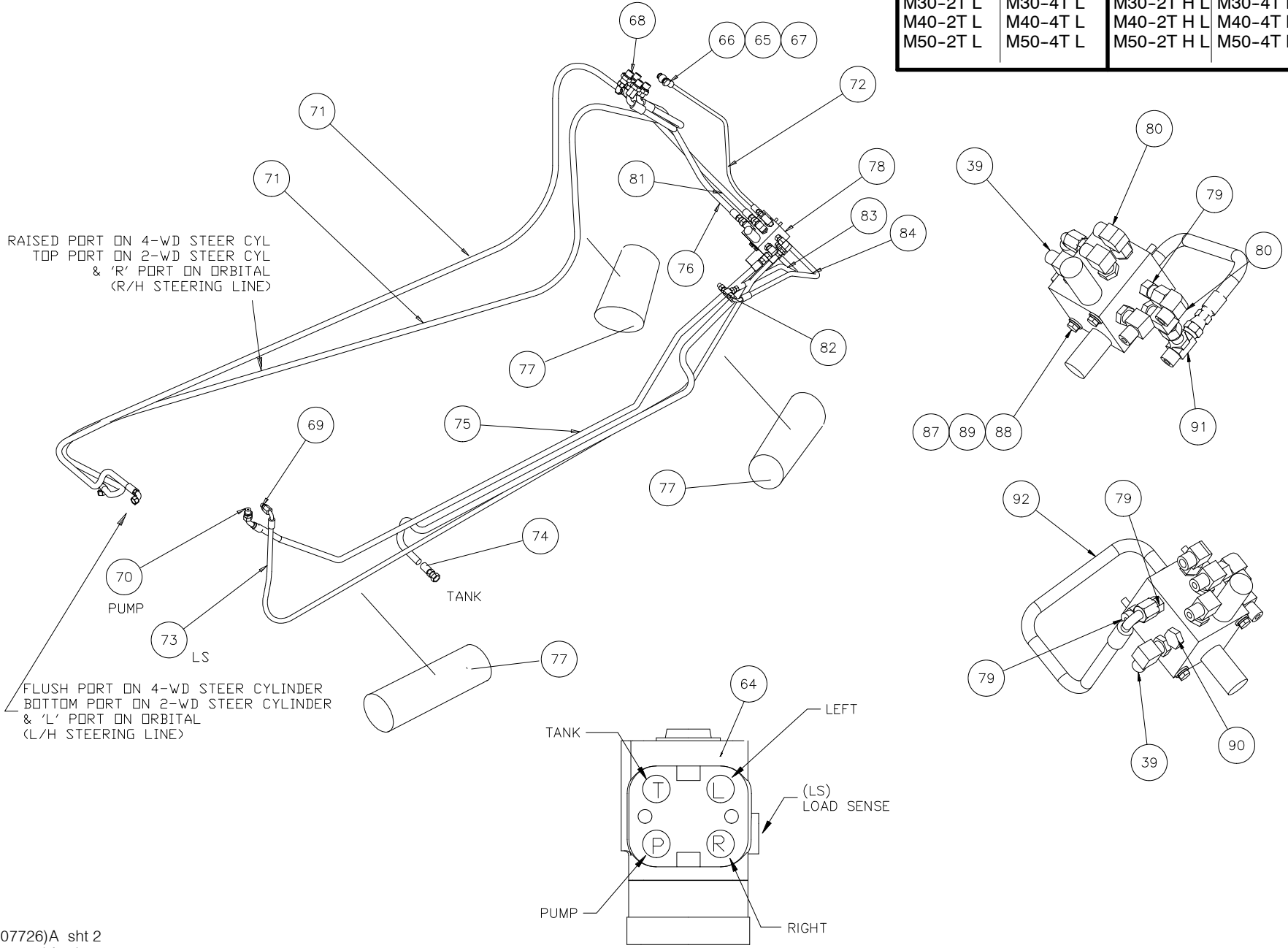

807726)A sht 2
807804)A sht 2

1	STEERING HYDRAULICS, 2WD AND 4WD		QUANTITY / MODEL											10 BA 302			
			M30-4T	M40-4T	M50-4T		M30-4T H	M40-4T H	M50-4T H		M30-4T L	M40-4T L	M50-4T L		M30-4T HL	M40-4T HL	M50-4T HL
ITEM	PART NO.	DESCRIPTION	M30-2T	M40-2T	M50-2T		M30-2T H	M40-2T H	M50-2T H		M30-2T L	M40-2T L	M50-2T L		M30-2T HL	M40-2T HL	M50-2T HL
64	197335	Steering orbital	1	1	1	1	1	1	1	1	1	1	1	1	1	1	1
65	207785	Spacer	1	1	1	1	1	1	1	1	1	1	1	1	1	1	1
66	207784	Screw, hollow	1	1	1	1	1	1	1	1	1	1	1	1	1	1	1
67	479275	Seal, copper	3	3	3	3	3	3	3	3	3	3	3	3	3	3	3
68	803188	Connector	4	4	4	4	4	4	4	4	4	4	4	4	4	4	4
69	803184	Connector	1	1	1	1	1	1	1	1	1	1	1	1	1	1	1
70	803177	Connector	1	1	1	1	1	1	1	1	1	1	1	1	1	1	1
71	803187	Hose assembly	2	2	2	2	2	2	2	2	2	2	2	2	2	2	2
72	803194	Hose assembly	1	1	1	1	1	1	1	1	1	1	1	1	1	1	1
73	807722	Hose assembly	1	1	1	1	1	1	1	1	1	1	1	1	1	1	1
74	807710	Hose assembly	1	1	1	1	1	1	1	1	1	1	1	1	1	1	1
75	807703	Hose assembly	1	1	1	1	1	1	1	1	1	1	1	1	1	1	1
76	807700	Hose assembly	1	1	1	1	1	1	1	1	1	1	1	1	1	1	1
77	Z4525	Sleeve, hose protection	81	81	81	81	81	81	81	81	81	81	81	81	81	81	81
78	807730	Block, manifold	1	1	1	1	1	1	1	1	1	1	1	1	1	1	1
79	806372	Connector	5	5	5	5	5	5	5	5	5	5	5	5	5	5	5
80	803199	Elbow	1	1	1	1	1	1	1	1	1	1	1	1	1	1	1
81	807699	Hose assembly	1	1	1	1	1	1	1	1	1	1	1	1	1	1	1
82	803198	Tee	1	1	1	1	1	1	1	1	1	1	1	1	1	1	1
83	807705	Hose assembly	1	1	1	1	1	1	1	1	1	1	1	1	1	1	1
84	807706	Hose assembly	1	1	1	1	1	1	1	1	1	1	1	1	1	1	1
85	803025	Hose assembly	1	1	1	1	1	1	1	1	1	1	1	1	1	1	1
86	807677	Connector	1	1	1	1	1	1	1	1	1	1	1	1	1	1	1
87	K34805	Washer	2	2	2	2	2	2	2	2	2	2	2	2	2	2	2
88	807773	Bolt	2	2	2	2	2	2	2	2	2	2	2	2	2	2	2
89	K44719	Washer	2	2	2	2	2	2	2	2	2	2	2	2	2	2	2
90	K64-6	Plug	1	1	1	1	1	1	1	1	1	1	1	1	1	1	1
91	R19831-2	Tee	1	1	1	1	1	1	1	1	1	1	1	1	1	1	1
92	807682	Hose assembly	1	1	1	1	1	1	1	1	1	1	1	1	1	1	1

10 CE 15
TIER III

STEERING CYLINDER, 2WD

M30-2T
M40-2T
M50-2T

M30-2T H
M40-2T H
M50-2T H

M30-2T L
M40-2T L
M50-2T L

M30-2T H L
M40-2T H L
M50-2T H L

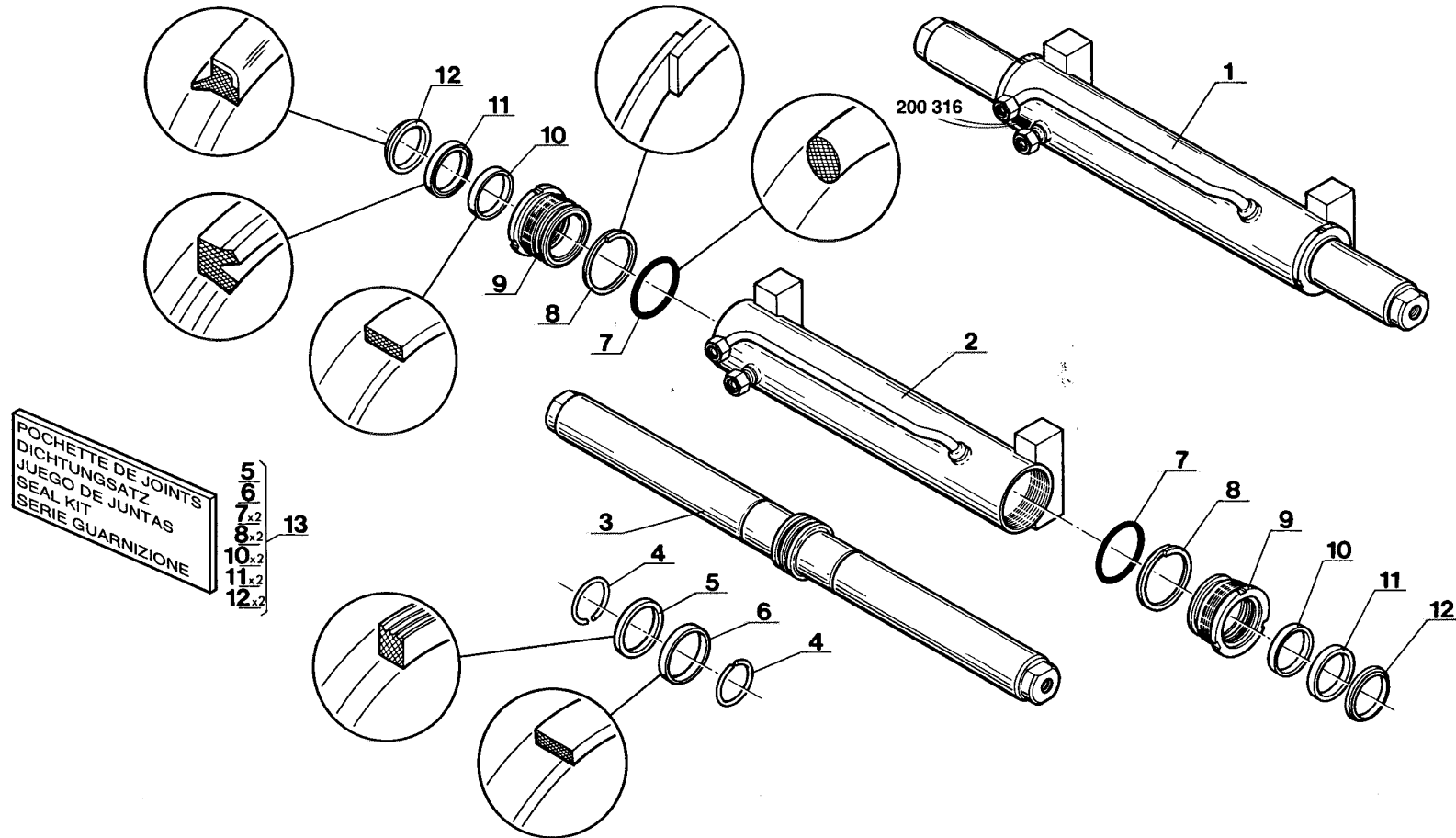
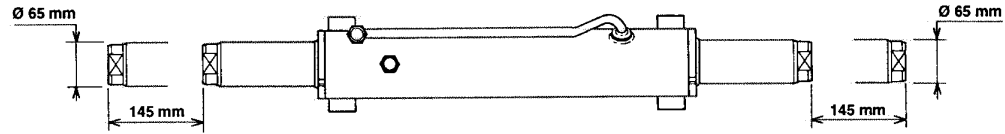

1	STEERING CYLINDER, 2WD		QUANTITY / MODEL									10 CE 15		
			M30-2T	M40-2T	M50-2T	M30-2T H	M40-2T H	M50-2T H	M30-2T L	M40-2T L	M50-2T L	M30-2T HL	M40-2T HL	M50-2T HL
ITEM	PART NO.	DESCRIPTION	M30-2T	M40-2T	M50-2T	M30-2T H	M40-2T H	M50-2T H	M30-2T L	M40-2T L	M50-2T L	M30-2T HL	M40-2T HL	M50-2T HL
1	200316	Steering cylinder, complete 2WD	1	1	1	1	1	1	1	1	1	1	1	1
2	561637	Cylinder body	1	1	1	1	1	1	1	1	1	1	1	1
3	561623	Cylinder rod	1	1	1	1	1	1	1	1	1	1	1	1
4	197670	Snap ring	2	2	2	2	2	2	2	2	2	2	2	2
5	561624	Seal	1	1	1	1	1	1	1	1	1	1	1	1
6	561625	Seal	1	1	1	1	1	1	1	1	1	1	1	1
7	5239	O-ring	2	2	2	2	2	2	2	2	2	2	2	2
8	187898	Seal, anti-extrusion	2	2	2	2	2	2	2	2	2	2	2	2
9	561622	Fastening ring	2	2	2	2	2	2	2	2	2	2	2	2
10	561621	Guide ring	2	2	2	2	2	2	2	2	2	2	2	2
11	561620	Seal	2	2	2	2	2	2	2	2	2	2	2	2
12	197709	Seal	2	2	2	2	2	2	2	2	2	2	2	2
13	551774	Seal kit	1	1	1	1	1	1	1	1	1	1	1	1

10 DA 318

TIER III

HYDRAULIC VALVE BANK ASSEMBLY

M30-2T	M30-4T	M30-2T H	M30-4T H
M40-2T	M40-4T	M40-2T H	M40-4T H
M50-2T	M50-4T	M50-2T H	M50-4T H

M30-2T L	M30-4T L	M30-2T H L	M30-4T H L
M40-2T L	M40-4T L	M40-2T H L	M40-4T H L
M50-2T L	M50-4T L	M50-2T H L	M50-4T H L

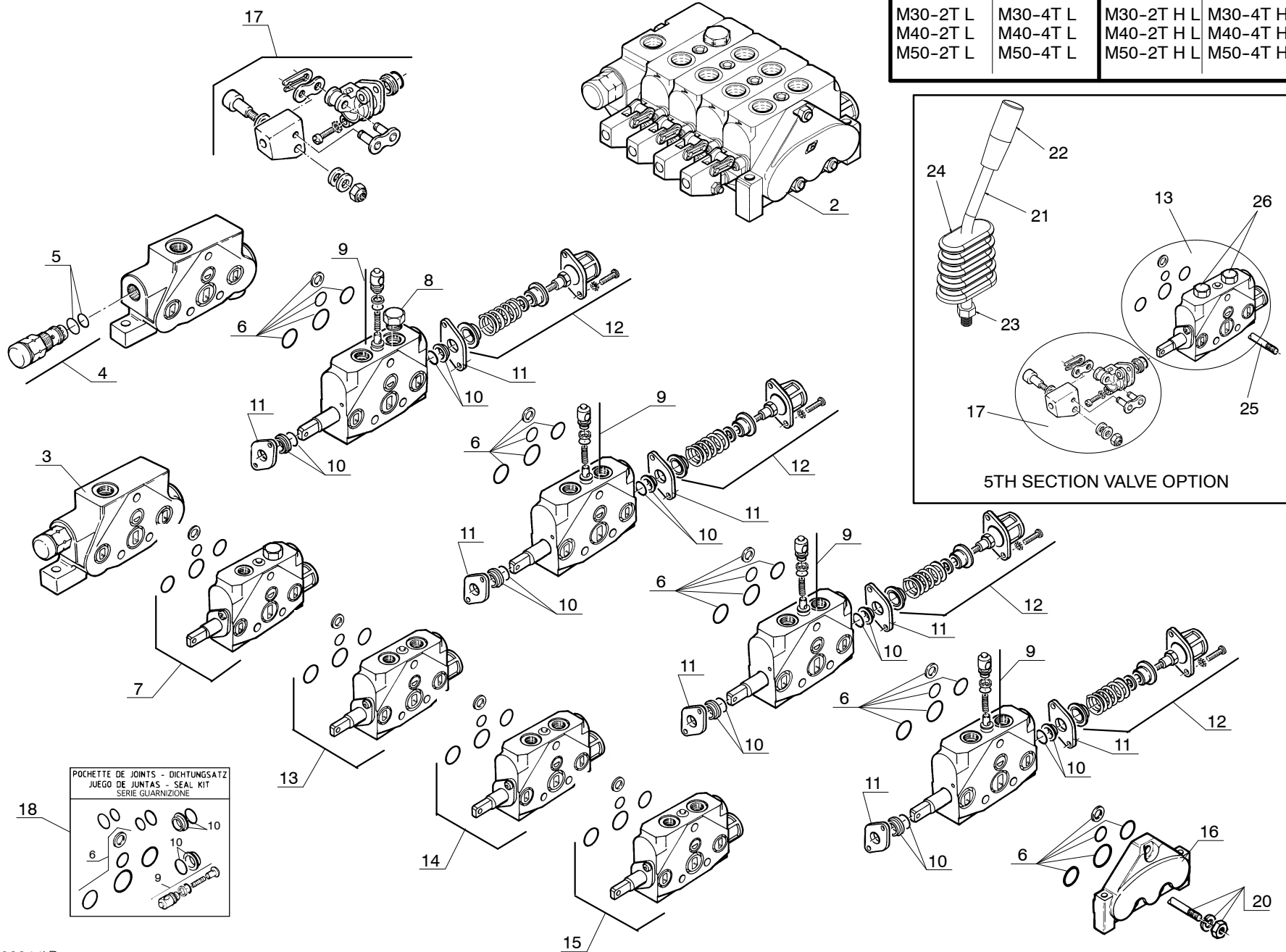

5TH SECTION VALVE OPTION

POCHETTE DE JOINTS - DICHTUNGSATZ
JUEGO DE JUNTAS - SEAL KIT
SERIE GUARNIZIONE

1	HYDRAULIC VALVE BANK ASSEMBLY		QUANTITY / MODEL											10 DA 318			
			M30-4T	M40-4T	M50-4T		M30-4T H	M40-4T H	M50-4T H		M30-4T L	M40-4T L	M50-4T L		M30-4T HL	M40-4T HL	M50-4T HL
ITEM	PART NO.	DESCRIPTION	M30-2T	M40-2T	M50-2T		M30-2T H	M40-2T H	M50-2T H		M30-2T L	M40-2T L	M50-2T L		M30-2T HL	M40-2T HL	M50-2T HL
2	209131	Valve bank assembly	1	1	1	1	1	1	1	1	1	1	1	1	1	1	1
3	551239	Inlet member	1	1	1	1	1	1	1	1	1	1	1	1	1	1	1
4	548112	Relief valve	1	1	1	1	1	1	1	1	1	1	1	1	1	1	1
5	476318	O-ring	A/R	A/R	A/R	A/R	A/R	A/R	A/R	A/R	A/R	A/R	A/R	A/R	A/R	A/R	A/R
6	476321	Seal	A/R	A/R	A/R	A/R	A/R	A/R	A/R	A/R	A/R	A/R	A/R	A/R	A/R	A/R	A/R
7	561340	Single acting member	1	1	1	1	1	1	1	1	1	1	1	1	1	1	1
8	476341	Plug	1	1	1	1	1	1	1	1	1	1	1	1	1	1	1
9	476322	Valve	A/R	A/R	A/R	A/R	A/R	A/R	A/R	A/R	A/R	A/R	A/R	A/R	A/R	A/R	A/R
10	476324	Seal	A/R	A/R	A/R	A/R	A/R	A/R	A/R	A/R	A/R	A/R	A/R	A/R	A/R	A/R	A/R
11	476325	Plate	A/R	A/R	A/R	A/R	A/R	A/R	A/R	A/R	A/R	A/R	A/R	A/R	A/R	A/R	A/R
12	548894	Spring return drive	A/R	A/R	A/R	A/R	A/R	A/R	A/R	A/R	A/R	A/R	A/R	A/R	A/R	A/R	A/R
13	476850	Double acting member	1	1	1	1	1	1	1	1	1	1	1	1	1	1	1
14	476850	Double acting member	1	1	1	1	1	1	1	1	1	1	1	1	1	1	1
15	476850	Double acting member	1	1	1	1	1	1	1	1	1	1	1	1	1	1	1
16	549774	Fastening member	1	1	1	1	1	1	1	1	1	1	1	1	1	1	1
17	549672	Single drive	A/R	A/R	A/R	A/R	A/R	A/R	A/R	A/R	A/R	A/R	A/R	A/R	A/R	A/R	A/R
18	192871	Seal kit	A/R	A/R	A/R	A/R	A/R	A/R	A/R	A/R	A/R	A/R	A/R	A/R	A/R	A/R	A/R
20	600726	Tie rod	1	1	1	1	1	1	1	1	1	1	1	1	1	1	1
21	801851	Lever, valve	1	1	1	1	1	1	1	1	1	1	1	1	1	1	1
22	202226	Handle, valve	1	1	1	1	1	1	1	1	1	1	1	1	1	1	1
23	58548	Nut	1	1	1	1	1	1	1	1	1	1	1	1	1	1	1
24	199728	Boot, single lever	1	1	1	1	1	1	1	1	1	1	1	1	1	1	1
25	600753	Tie rod	3	3	3	3	3	3	3	3	3	3	3	3	3	3	3
26	175743	Plug	2	2	2	2	2	2	2	2	2	2	2	2	2	2	2

10 DA 320
TIER III

HYDRAULIC VALVE BANK ASSEMBLY OPTION,
FOR FRAME LEVELING MODELS ONLY

M30-2T L	M30-4T L	M30-2T H L	M30-4T H L
M40-2T L	M40-4T L	M40-2T H L	M40-4T H L
M50-2T L	M50-4T L	M50-2T H L	M50-4T H L

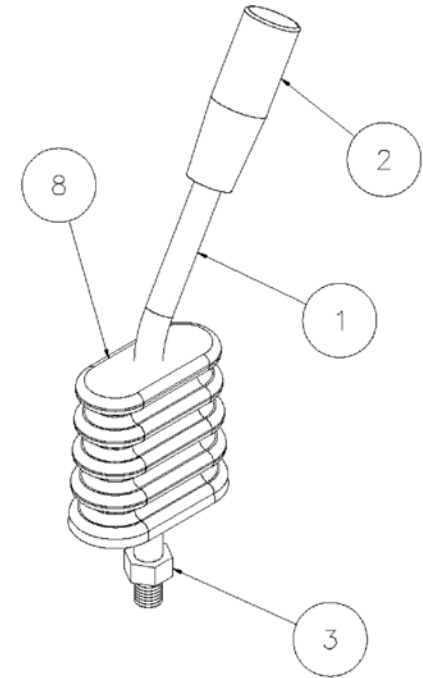
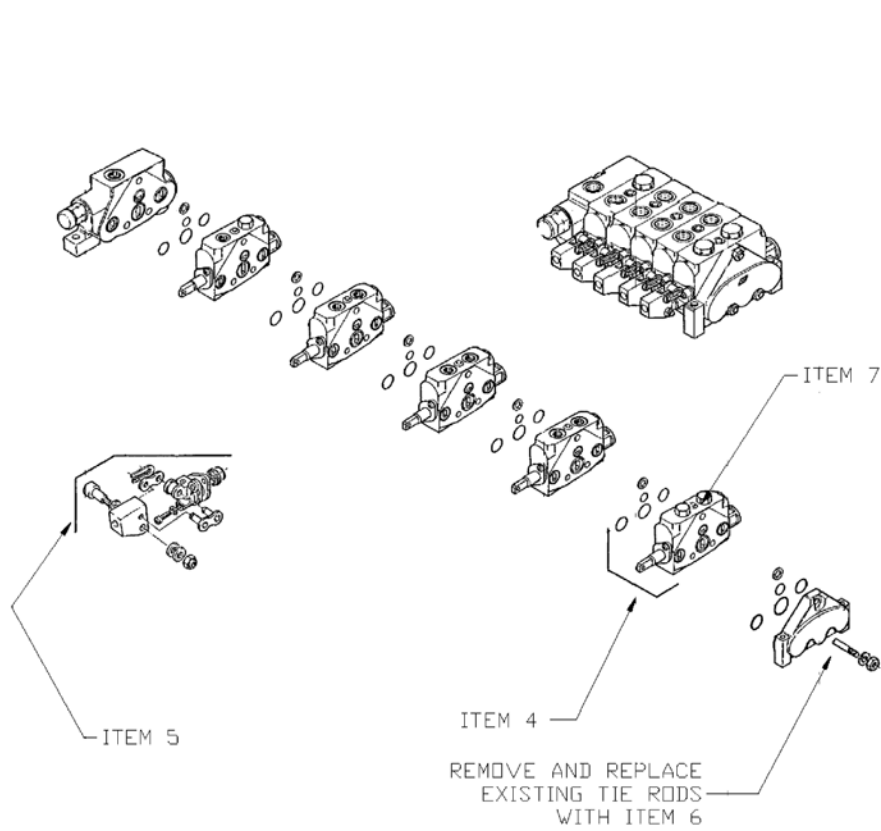

1	HYDRAULIC VALVE BANK ASSEMBLY OPTION, FOR FRAME LEVELING MODELS ONLY		QUANTITY / MODEL						10 DA 320					
									M30-4T L	M40-4T L	M50-4T L	M30-4T HL	M40-4T HL	M50-4T HL
ITEM	PART NO.	DESCRIPTION							M30-2T L	M40-2T L	M50-2T L	M30-2T HL	M40-2T HL	M50-2T HL
1	801851	Lever, valve							1	1	1	1	1	1
2	202226	Handle, valve							1	1	1	1	1	1
3	58548	Nut							1	1	1	1	1	1
4	476850	Double acting member							1	1	1	1	1	1
5	549672	Single drive							1	1	1	1	1	1
6	600753	Tie rod							3	3	3	3	3	3
7	175743	Plug							2	2	2	2	2	2
8	199728	Boot, single lever							1	1	1	1	1	1

64.00

APPLY DI-ELECTRIC GREASE TO ALL CONNECTIONS
 "CONNECTORS" - AS SEEN FROM THE BACK

11 AA 1035
 TIER III

ELECTRICAL ASSEMBLY, 4-SPEED
 (SHEET 1 OF 2)

M30-2T	M30-4T
M40-2T	M40-4T
M50-2T	M50-4T

M30-2T L	M30-4T L
M40-2T L	M40-4T L
M50-2T L	M50-4T L

807671B

CIRCUIT BREAKER IDENTIFICATION	WIRE COLOR "A"	WIRE COLOR "B"
01 - STARTER (20A)	PURPLE	PURPLE
02 - WORK LIGHTS (20A)	RED	RED
03 - DASH PANEL (5A)	BLUE,RED,RED/BLACK	RED
04 - FNR (10A)	ORANGE,RED,RED/BLACK	RED
05 - HORN (10A)	RED,GREEN	RED
06 - PARK BRAKE (10A)	ORANGE	RED
07 - 2 SPEED GEAR BOX,TC (10A)	BROWN	RED
08 - ROAD LIGHTS (15A)	RED	YELLOW
09 - BEACON (10A)	RED	RED
10 - GAUGES ENGINE SHUTDOWN (10A)	RED	RED
11 - FRAME LEVEL (5A)	RED	RED
12 - WARNING (10A)	RED	YELLOW
13 - RIGHT HAND TURN SIGNAL (10A)	GRAY	GRAY
14 - LEFT HAND TURN SIGNAL (10A)	BLACK	BLACK
15 - FLASHER UNIT (10A)	RED	RED
16 - FRONT WIPER (10A)	PINK	RED
17 - REAR WIPER (10A)	RED	RED
18 - HEATER (15A)	RED	RED
19 - DOME LIGHT (3A)	YELLOW	YELLOW
20 - OPEN	RED	RED
41 - FUSES FOR EQUIPMENT (40A)	YELLOW	
42 - ENGINE PREHEAT (80A)	BLACK	
43 - ALTERNATOR (80A)	WHITE	

LEGEND:

- VI - VIOLET
- BC - WHITE
- RD - PINK
- R - RED
- N - BLACK
- J - YELLOW
- V - GREEN
- M - BROWN
- BL - BLUE
- O - ORANGE
- G - GRAY

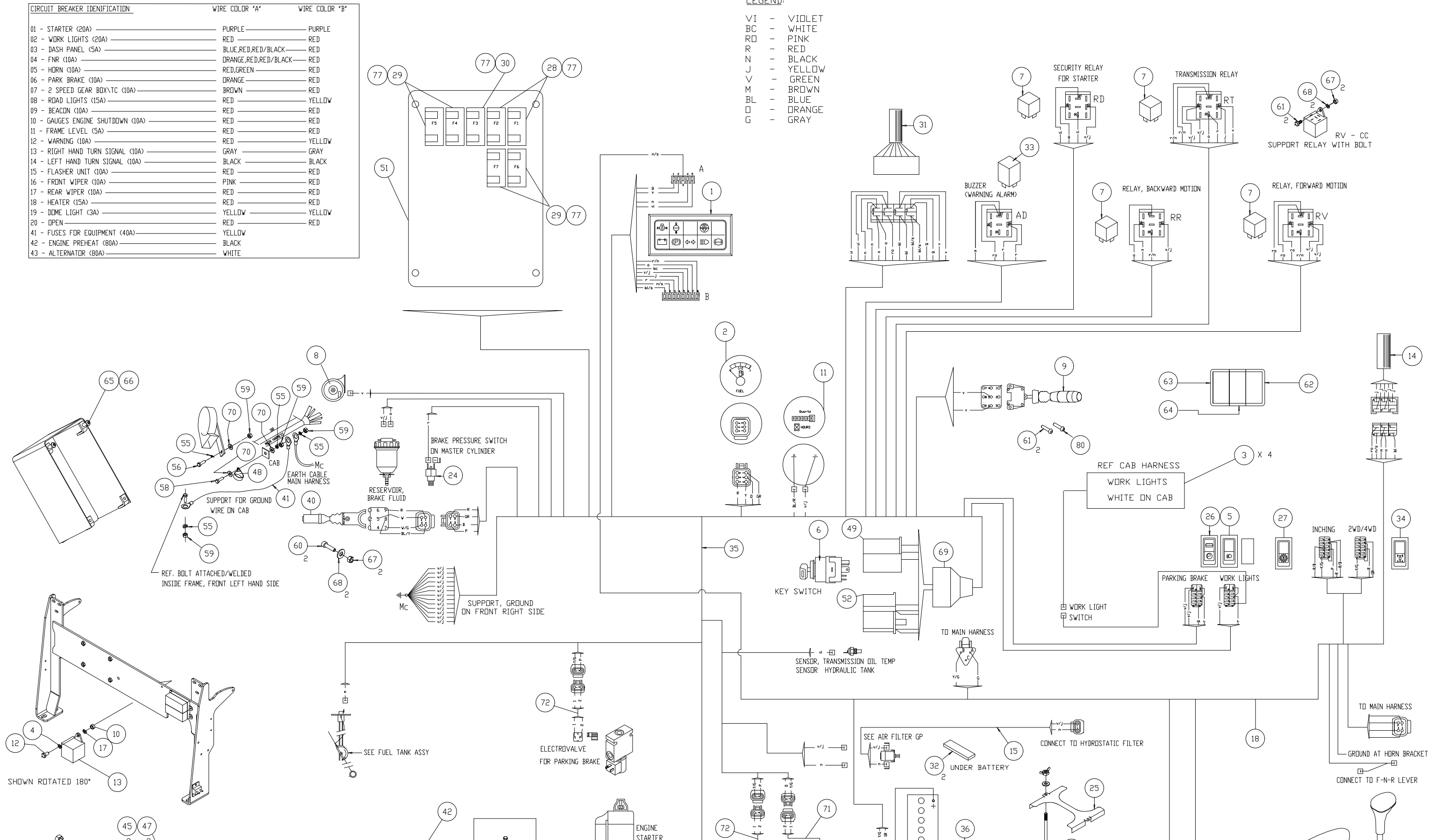

11 AA 1035
TIER III

ELECTRICAL ASSEMBLY, 4-SPEED
(SHEET 2 OF 2)

M30-2T M40-2T M50-2T	M30-4T M40-4T M50-4T		
M30-2T L M40-2T L M50-2T L	M30-4T L M40-4T L M50-4T L		

APPLY DI-ELECTRIC GREASE TO ALL CONNECTIONS

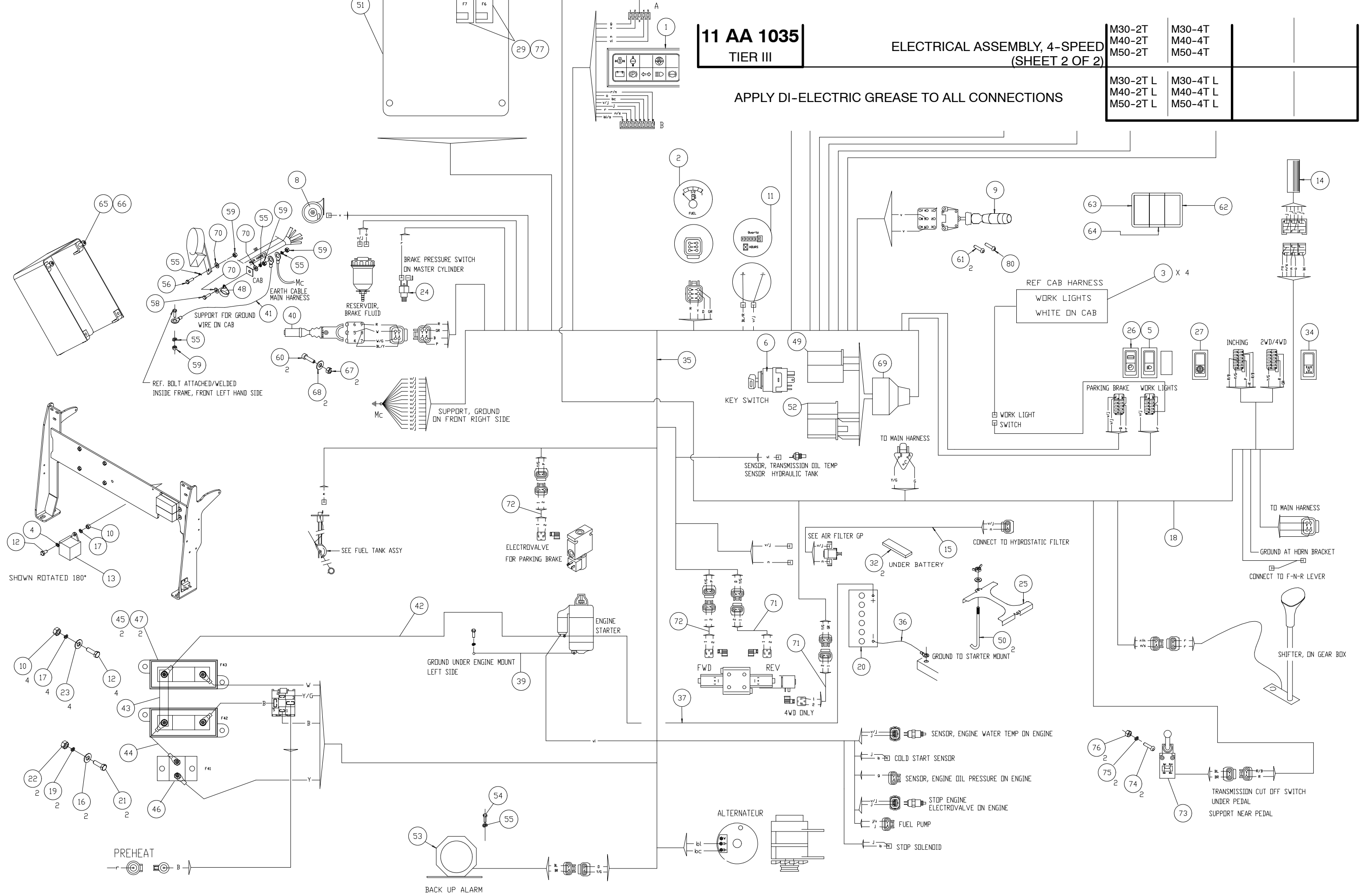

PREHEAT

BACK UP ALARM

			QUANTITY / MODEL												11 AA 1035				
1 ELECTRICAL ASSEMBLY, 4-SPEED			M30-4T	M40-4T	M50-4T							M30-4T L	M40-4T L	M50-4T L					
ITEM	PART NO.	DESCRIPTION	M30-2T	M40-2T	M50-2T							M30-2T L	M40-2T L	M50-2T L					
1	686343	Panel, warning lights	1	1	1	1						1	1	1	1				
2	807664	Fuel gauge	1	1	1	1						1	1	1	1				
3	807514	Light, white work	4	4	4	4						4	4	4	4				
4	174132	Washer	1	1	1	1						1	1	1	1				
5	807667	Switch, work light	1	1	1	1						1	1	1	1				
6	184817	Ignition switch	1	1	1	1						1	1	1	1				
7	807121	Relay	4	4	4	4						4	4	4	4				
8	20125	Horn	1	1	1	1						1	1	1	1				
9	191384	Lever, lighting, horn	1	1	1	1						1	1	1	1				
10	25714	Nut	5	5	5	5						5	5	5	5				
11	807665	Hourmeter	1	1	1	1						1	1	1	1				
12	46668	Bolt	5	5	5	5						5	5	5	5				
13	243482	Relay	1	1	1	1						1	1	1	1				
14	223246	Relay, delay	1	1	1	1						1	1	1	1				
15	802936	Harness assembly	1	1	1	1						1	1	1	1				
16	28959	Washer	2	2	2	2						2	2	2	2				
17	42316	Washer, lock	5	5	5	5						5	5	5	5				
18	807670	Harness TC	1	1	1	1						1	1	1	1				
19	192310	Washer, lock	2	2	2	2						2	2	2	2				
20	----	Battery, purchase locally	1	1	1	1						1	1	1	1				
21	61974	Bolt	2	2	2	2						2	2	2	2				
22	54232	Nut	2	2	2	2						2	2	2	2				
23	29469	Washer	5	5	5	5						5	5	5	5				
24	79126	Stop switch, brake lights	1	1	1	1						1	1	1	1				
25	202703	Strap, battery	1	1	1	1						1	1	1	1				
26	806132	Park brake switch	1	1	1	1						1	1	1	1				
27	805947	Inching enable switch	1	1	1	1						1	1	1	1				
28	805887	Breaker, 10 A	2	2	2	2						2	2	2	2				
29	805888	Breaker, 20 A	4	4	4	4						4	4	4	4				

65.00

			QUANTITY / MODEL											11 AA 1035					
2			ELECTRICAL ASSEMBLY, 4-SPEED																
ITEM	PART NO.	DESCRIPTION	M30-2T	M40-2T	M50-2T							M30-4T L	M40-4T L	M50-4T L					
30	805889	Breaker, 5 A	1	1	1	1						1	1	1	1				
31	210942	Test module	1	1	1	1						1	1	1	1				
32	41077	Strip, rubber	2	2	2	2						2	2	2	2				
33	176737	Buzzer	1	1	1	1						1	1	1	1				
34	805946	2WD / 4WD switch (4WD Models ONLY)	1	1	1	1						1	1	1	1				
35	807659	Wire harness, main	1	1	1	1						1	1	1	1				
36	720991	Cable, negative battery	1	1	1	1						1	1	1	1				
37	802937	Cable, positive battery	1	1	1	1						1	1	1	1				
39	802977	Cable, negative ground	1	1	1	1						1	1	1	1				
40	807666	Shifter, F-N-R	1	1	1	1						1	1	1	1				
41	215875	Earth cable	1	1	1	1						1	1	1	1				
42	232402	Cable	1	1	1	1						1	1	1	1				
43	804930	Buss bar	1	1	1	1						1	1	1	1				
44	804661	Wire assembly	1	1	1	1						1	1	1	1				
45	804832	Fuse, 80 amp	2	2	2	2						2	2	2	2				
46	804641	Breaker, 40 amp	1	1	1	1						1	1	1	1				
47	804831	Fuse holder	2	2	2	2						2	2	2	2				
48	86506	Clamp	1	1	1	1						1	1	1	1				
49	602567	Connector	1	1	1	1						1	1	1	1				
50	496687	J Hook, wing nut and washer	2	2	2	2						2	2	2	2				
51	807568	Cover plate	1	1	1	1						1	1	1	1				
52	602568	Connector	1	1	1	1						1	1	1	1				
53	805907	Alarm, backup	1	1	1	1						1	1	1	1				
54	209375	Bolt	2	2	2	2						2	2	2	2				
55	42325	Washer	6	6	6	6						6	6	6	6				
56	54951	Screw	2	2	2	2						2	2	2	2				
57	42347	Screw	1	1	1	1						1	1	1	1				
58	168348	Screw	1	1	1	1						1	1	1	1				
59	58528	Nut	5	5	5	5						5	5	5	5				

			QUANTITY / MODEL											11 AA 1035				
			M30-4T	M40-4T	M50-4T						M30-4T L	M40-4T L	M50-4T L					
3	ELECTRICAL ASSEMBLY, 4-SPEED		M30-2T	M40-2T	M50-2T							M30-2T L	M40-2T L	M50-2T L				
ITEM	PART NO.	DESCRIPTION																
60	5323	Screw	2	2	2	2						2	2	2	2			
61	79533	Screw	4	4	4	4						4	4	4	4			
62	196905	Plug	7	7	7	7						7	7	7	7			
63	224774	Switch holder	6	6	6	6						6	6	6	6			
64	224773	Switch holder misc.	3	3	3	3						3	3	3	3			
65	807565	Cover assembly	1	1	1	1						1	1	1	1			
66	196951	Screw	4	4	4	4						4	4	4	4			
67	54232	Nut	6	6	6	6						6	6	6	6			
68	28959	Washer	6	6	6	6						6	6	6	6			
69	812087	Boot, key switch	1	1	1	1						1	1	1	1			
70	61674	Washer	3	3	3	3						3	3	3	3			
71	805923	Cable assembly	2	2	2	2						2	2	2	2			
72	805924	Cable assembly	2	2	2	2						2	2	2	2			
73	219100	Transmission cut-off switch	1	1	1	1						1	1	1	1			
74	802986	Screw	2	2	2	2						2	2	2	2			
75	78806	Washer	2	2	2	2						2	2	2	2			
76	25758	Nut	2	2	2	2						2	2	2	2			
77	806341	Boot, breaker	1	1	1	1						1	1	1	1			

APPLY DI-ELECTRIC GREASE TO ALL CONNECTIONS

11 AA 1036
TIER III

ELECTRICAL ASSEMBLY, HYDROSTATIC
(SHEET 1 OF 2)

807663)C

M30-2T H M30-4T H
M40-2T H M40-4T H
M50-2T H M50-4T H

M30-2T H L M30-4T H L
M40-2T H L M40-4T H L
M50-2T H L M50-4T H L

CIRCUIT BREAKER IDENTIFICATION	WIRE COLOR 'A'	WIRE COLOR 'B'
01 - STARTER (20A)	PURPLE	PURPLE
02 - WORK LIGHTS (20A)	RED	RED
03 - DASH PANEL (5A)	BLUE,RED,RED/BLACK	RED
04 - FNR (10A)	ORANGE,RED,RED/BLACK	RED
05 - HORN (10A)	RED,GREEN	RED
06 - PARK BRAKE (10A)	ORANGE	RED
07 - 2 SPEED GEAR BOX (10A)	BROWN	RED
08 - ROAD LIGHTS (15A)	RED	YELLOW
09 - BEACON (10A)	RED	RED
10 - GAUGES ENGINE SHUTDOWN (10A)	RED	RED
11 - FRAME LEVEL (5A)	RED	RED
12 - WARNING (10A)	RED	YELLOW
13 - RIGHT HAND TURN SIGNAL (10A)	GRAY	GRAY
14 - LEFT HAND TURN SIGNAL (10A)	BLACK	BLACK
15 - FLASHER UNIT (10A)	RED	RED
16 - FRONT WIPER (10A)	PINK	RED
17 - REAR WIPER (10A)	RED	RED
18 - HEATER (15A)	RED	RED
19 - DOME LIGHT (3A)	YELLOW	YELLOW
20 - OPEN	RED	RED
41 - FUSES FOR EQUIPMENT (40A)	YELLOW	
42 - ENGINE PREHEAT (80A)	BLACK	
43 - ALTERNATOR (80A)	WHITE	

LEGEND:

- VI - VIOLET
- BC - WHITE
- RD - PINK
- R - RED
- N - BLACK
- J - YELLOW
- V - GREEN
- M - BROWN
- BL - BLUE
- O - ORANGE
- G - GRAY

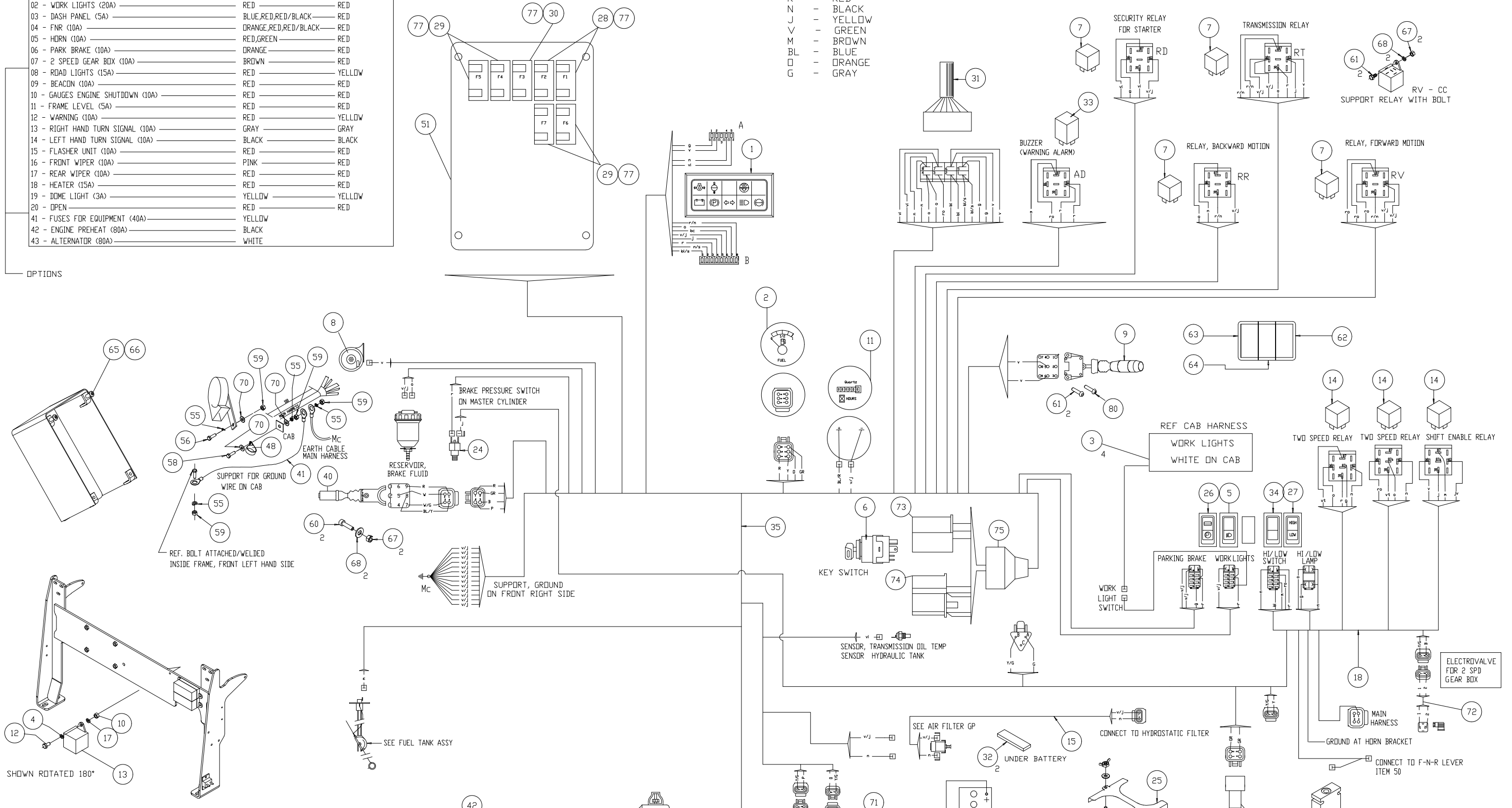

OPTIONS

REF. BOLT ATTACHED/WELDED
INSIDE FRAME, FRONT LEFT HAND SIDE

SUPPORT, GROUND
ON FRONT RIGHT SIDE

SHOWN ROTATED 180°

SEE FUEL TANK ASSY

SEE AIR FILTER GP

CONNECT TO HYDROSTATIC FILTER

GROUND AT HORN BRACKET

CONNECT TO F-N-R LEVER
ITEM 50

ELECTROVALVE
FOR 2 SPD
GEAR BOX

13 - RIGHT HAND TURN SIGNAL (10A)	GRAY	GRAY
14 - LEFT HAND TURN SIGNAL (10A)	BLACK	BLACK
15 - FLASHER UNIT (10A)	RED	RED
16 - FRONT WIPER (10A)	PINK	RED
17 - REAR WIPER (10A)	RED	RED
18 - HEATER (15A)	RED	RED
19 - DOME LIGHT (3A)	YELLOW	YELLOW
20 - OPEN	RED	RED
41 - FUSES FOR EQUIPMENT (40A)	YELLOW	
42 - ENGINE PREHEAT (80A)	BLACK	
43 - ALTERNATOR (80A)	WHITE	

OPTIONS

11 AA 1036
TIER III

ELECTRICAL ASSEMBLY, HYDROSTATIC
(SHEET 2 OF 2)

M30-2T H	M30-4T H
M40-2T H	M40-4T H
M50-2T H	M50-4T H
M30-2T H L	M30-4T H L
M40-2T H L	M40-4T H L
M50-2T H L	M50-4T H L

APPLY DI-ELECTRIC GREASE TO ALL CONNECTIONS

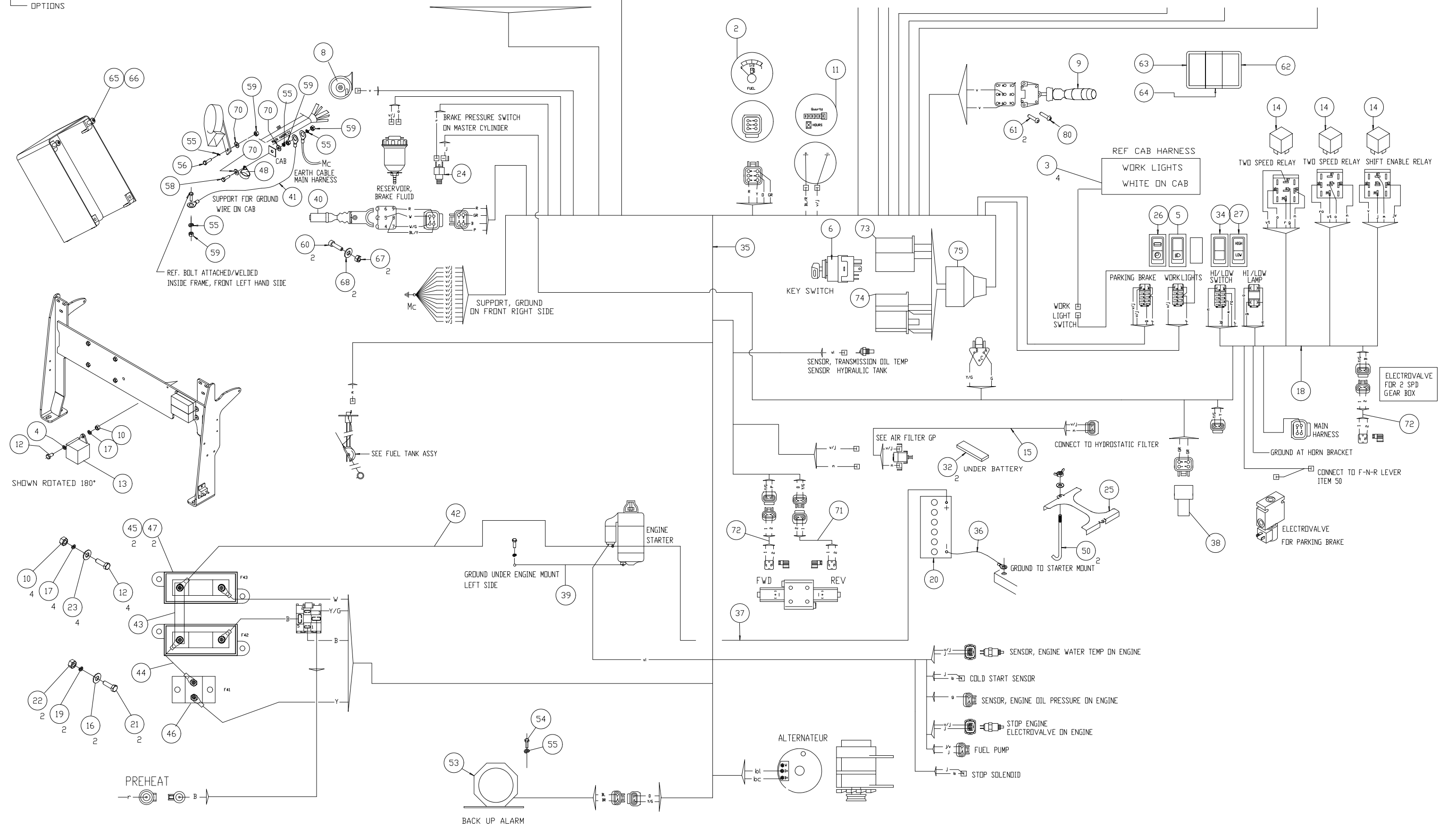

1	ELECTRICAL ASSEMBLY, 4-SPEED		QUANTITY / MODEL											11 AA 1036					
			M30-4T	M40-4T	M50-4T						M30-4T L	M40-4T L	M50-4T L						
			M30-2T	M40-2T	M50-2T						M30-2T L	M40-2T L	M50-2T L						
ITEM	PART NO.	DESCRIPTION	M30-2T	M40-2T	M50-2T							M30-2T L	M40-2T L	M50-2T L					
1	686343	Panel, warning lights	1	1	1	1						1	1	1	1				
2	807664	Fuel gauge	1	1	1	1						1	1	1	1				
3	807514	Light, white work	4	4	4	4						4	4	4	4				
4	174132	Washer	1	1	1	1						1	1	1	1				
5	807667	Switch, work light	1	1	1	1						1	1	1	1				
6	184817	Ignition switch	1	1	1	1						1	1	1	1				
7	807121	Relay	4	4	4	4						4	4	4	4				
8	20125	Horn	1	1	1	1						1	1	1	1				
9	191384	Lever, lighting, horn	1	1	1	1						1	1	1	1				
10	25714	Nut	5	5	5	5						5	5	5	5				
11	807665	Hourmeter	1	1	1	1						1	1	1	1				
12	46668	Bolt	5	5	5	5						5	5	5	5				
13	243482	Relay	1	1	1	1						1	1	1	1				
14	806876	Relay	1	1	1	1						1	1	1	1				
15	802936	Harness assembly	1	1	1	1						1	1	1	1				
16	28959	Washer	2	2	2	2						2	2	2	2				
17	42316	Washer, lock	5	5	5	5						5	5	5	5				
18	807662	Harness, 2 speed	1	1	1	1						1	1	1	1				
19	192310	Washer, lock	2	2	2	2						2	2	2	2				
20	- - - -	Battery, purchase locally	1	1	1	1						1	1	1	1				
21	61974	Bolt	2	2	2	2						2	2	2	2				
22	54232	Nut	2	2	2	2						2	2	2	2				
23	29469	Washer	5	5	5	5						5	5	5	5				
24	79126	Stop switch, brake lights	1	1	1	1						1	1	1	1				
25	202703	Strap, battery	1	1	1	1						1	1	1	1				
26	806132	Park brake switch	1	1	1	1						1	1	1	1				
27	231464	Indicator light	1	1	1	1						1	1	1	1				
28	805887	Breaker, 10 A	2	2	2	2						2	2	2	2				
29	805888	Breaker, 20 A	4	4	4	4						4	4	4	4				

			QUANTITY / MODEL										11 AA 1036					
			M30-4T	M40-4T	M50-4T						M30-4T L	M40-4T L	M50-4T L					
2	ELECTRICAL ASSEMBLY, 4-SPEED		M30-2T	M40-2T	M50-2T							M30-2T L	M40-2T L	M50-2T L				
ITEM	PART NO.	DESCRIPTION																
30	805889	Breaker, 5 A	1	1	1	1						1	1	1	1			
31	210942	Test module	1	1	1	1						1	1	1	1			
32	41077	Strip, rubber	2	2	2	2						2	2	2	2			
33	176737	Buzzer	1	1	1	1						1	1	1	1			
34	805957	2 speed switch	1	1	1	1						1	1	1	1			
35	807659	Wire harness, main	1	1	1	1						1	1	1	1			
36	720991	Cable, negative battery	1	1	1	1						1	1	1	1			
37	802937	Cable, positive battery	1	1	1	1						1	1	1	1			
38	800465	Module diode	1	1	1	1						1	1	1	1			
39	802977	Cable, negative ground	1	1	1	1						1	1	1	1			
40	807666	Shifter, F-N-R	1	1	1	1						1	1	1	1			
41	215875	Earth cable	1	1	1	1						1	1	1	1			
42	232402	Cable	1	1	1	1						1	1	1	1			
43	804930	Buss bar	1	1	1	1						1	1	1	1			
44	804661	Wire assembly	1	1	1	1						1	1	1	1			
45	804832	Fuse, 80 amp	2	2	2	2						2	2	2	2			
46	804641	Breaker, 40 amp	1	1	1	1						1	1	1	1			
47	804831	Fuse holder	2	2	2	2						2	2	2	2			
48	86506	Clamp	1	1	1	1						1	1	1	1			
50	496687	J Hook, wing nut and washer	2	2	2	2						2	2	2	2			
51	807568	Cover plate	1	1	1	1						1	1	1	1			
53	805907	Alarm, backup	1	1	1	1						1	1	1	1			
54	209375	Bolt	2	2	2	2						2	2	2	2			
55	42325	Washer	6	6	6	6						6	6	6	6			
56	54951	Screw	2	2	2	2						2	2	2	2			
57	42347	Screw	1	1	1	1						1	1	1	1			
58	168348	Screw	1	1	1	1						1	1	1	1			
59	58528	Nut	5	5	5	5						5	5	5	5			

			QUANTITY / MODEL										11 AA 1036						
			M30-4T	M40-4T	M50-4T						M30-4T L	M40-4T L	M50-4T L						
3	ELECTRICAL ASSEMBLY, 4-SPEED		M30-2T	M40-2T	M50-2T							M30-2T L	M40-2T L	M50-2T L					
ITEM	PART NO.	DESCRIPTION																	
60	160573	Screw	2	2	2	2						2	2	2	2				
61	79533	Screw	4	4	4	4						4	4	4	4				
62	196905	Plug	7	7	7	7						7	7	7	7				
63	224774	Switch holder	6	6	6	6						6	6	6	6				
64	224773	Switch holder misc.	3	3	3	3						3	3	3	3				
65	807565	Cover assembly	1	1	1	1						1	1	1	1				
66	196951	Screw	4	4	4	4						4	4	4	4				
67	54232	Nut	6	6	6	6						6	6	6	6				
68	28959	Washer	6	6	6	6						6	6	6	6				
70	61674	Washer	3	3	3	3						3	3	3	3				
71	805923	Cable assembly	2	2	2	2						2	2	2	2				
72	805924	Cable assembly	2	2	2	2						2	2	2	2				
73	602567	Connector	1	1	1	1						1	1	1	1				
74	602568	Connector	2	2	2	2						2	2	2	2				
75	812087	Boot, key switch	1	1	1	1						1	1	1	1				
77	806341	Boot, breaker	1	1	1	1						1	1	1	1				

11 BA 103
TIER III

ELECTRICAL, OVERHEAD WORK LIGHTS

M30-2T	M30-4T	M30-2T H	M30-4T H
M40-2T	M40-4T	M40-2T H	M40-4T H
M50-2T	M50-4T	M50-2T H	M50-4T H
M30-2T L	M30-4T L	M30-2T H L	M30-4T H L
M40-2T L	M40-4T L	M40-2T H L	M40-4T H L
M50-2T L	M50-4T L	M50-2T H L	M50-4T H L

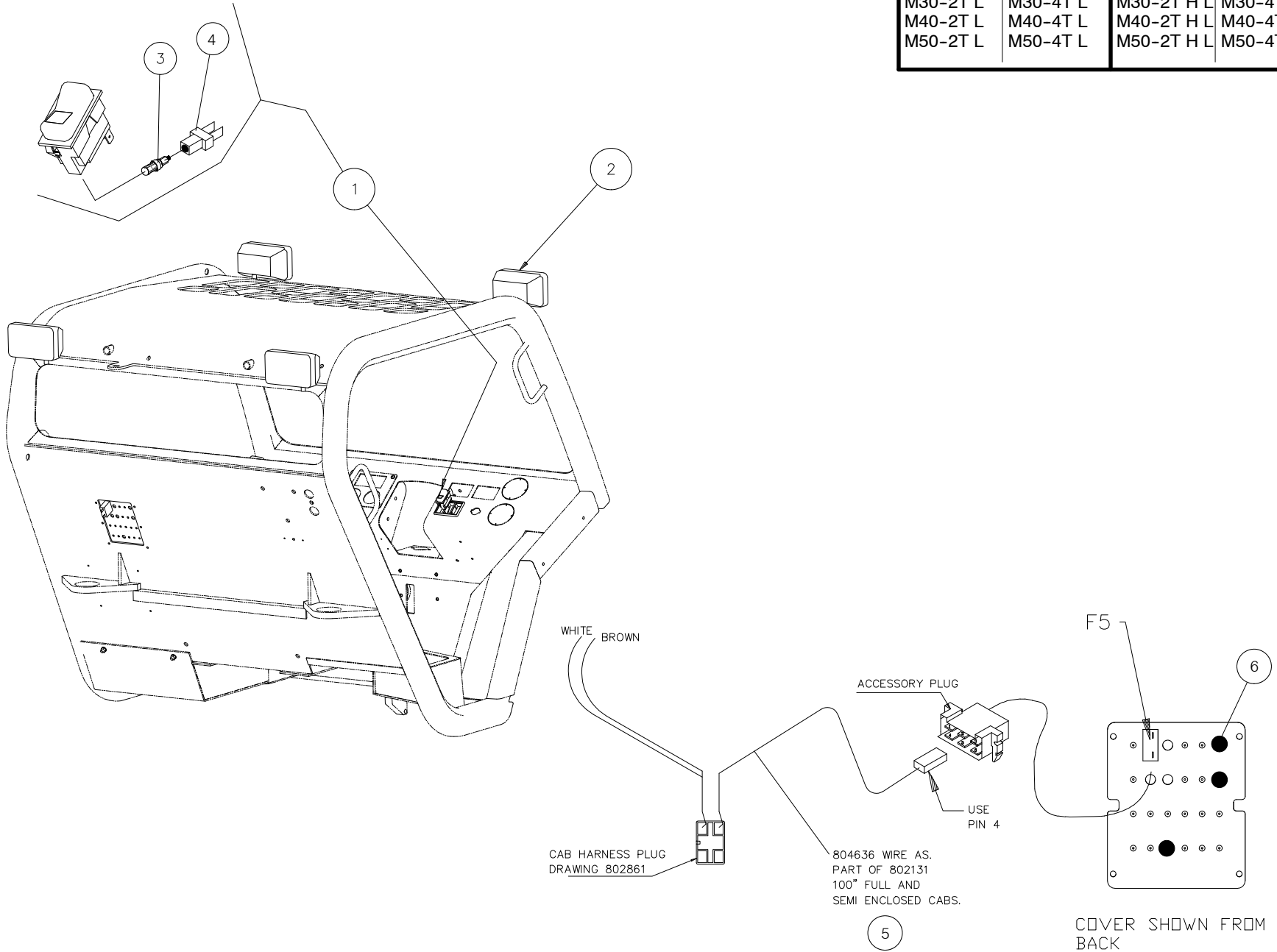

			QUANTITY / MODEL											11 BA 103					
			M30-4T	M40-4T	M50-4T		M30-4T H	M40-4T H	M50-4T H		M30-4T L	M40-4T L	M50-4T L		M30-4T HL	M40-4T HL	M50-4T HL		
ITEM	PART NO.	DESCRIPTION	M30-2T	M40-2T	M50-2T		M30-2T H	M40-2T H	M50-2T H		M30-2T L	M40-2T L	M50-2T L		M30-2T HL	M40-2T HL	M50-2T HL		
1	487961	Switch, work lights (less bulb and bulb holder)	1	1	1	1	1	1	1	1	1	1	1	1	1	1	1	1	1
2	807514	Light, work	4	4	4	4	4	4	4	4	4	4	4	4	4	4	4	4	4
3	170836	Light bulb	1	1	1	1	1	1	1	1	1	1	1	1	1	1	1	1	1
4	554629	Bulb holder	1	1	1	1	1	1	1	1	1	1	1	1	1	1	1	1	1
5	804636	Wire assembly	1	1	1	1	1	1	1	1	1	1	1	1	1	1	1	1	1
6	807156	Plug	A/R	A/R	A/R	A/R	A/R	A/R	A/R	A/R	A/R	A/R	A/R	A/R	A/R	A/R	A/R	A/R	A/R

11 BA 119
TIER III

ELECTRICAL, FRONT OVERHEAD WORK LIGHTS

M30-2T	M30-4T	M30-2T H	M30-4T H
M40-2T	M40-4T	M40-2T H	M40-4T H
M50-2T	M50-4T	M50-2T H	M50-4T H
M30-2T L	M30-4T L	M30-2T H L	M30-4T H L
M40-2T L	M40-4T L	M40-2T H L	M40-4T H L
M50-2T L	M50-4T L	M50-2T H L	M50-4T H L

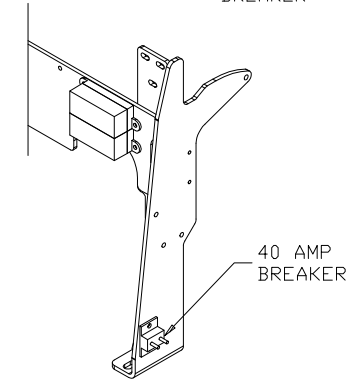
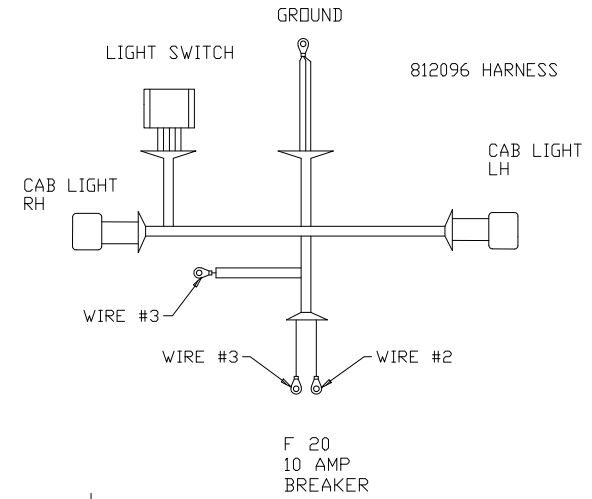
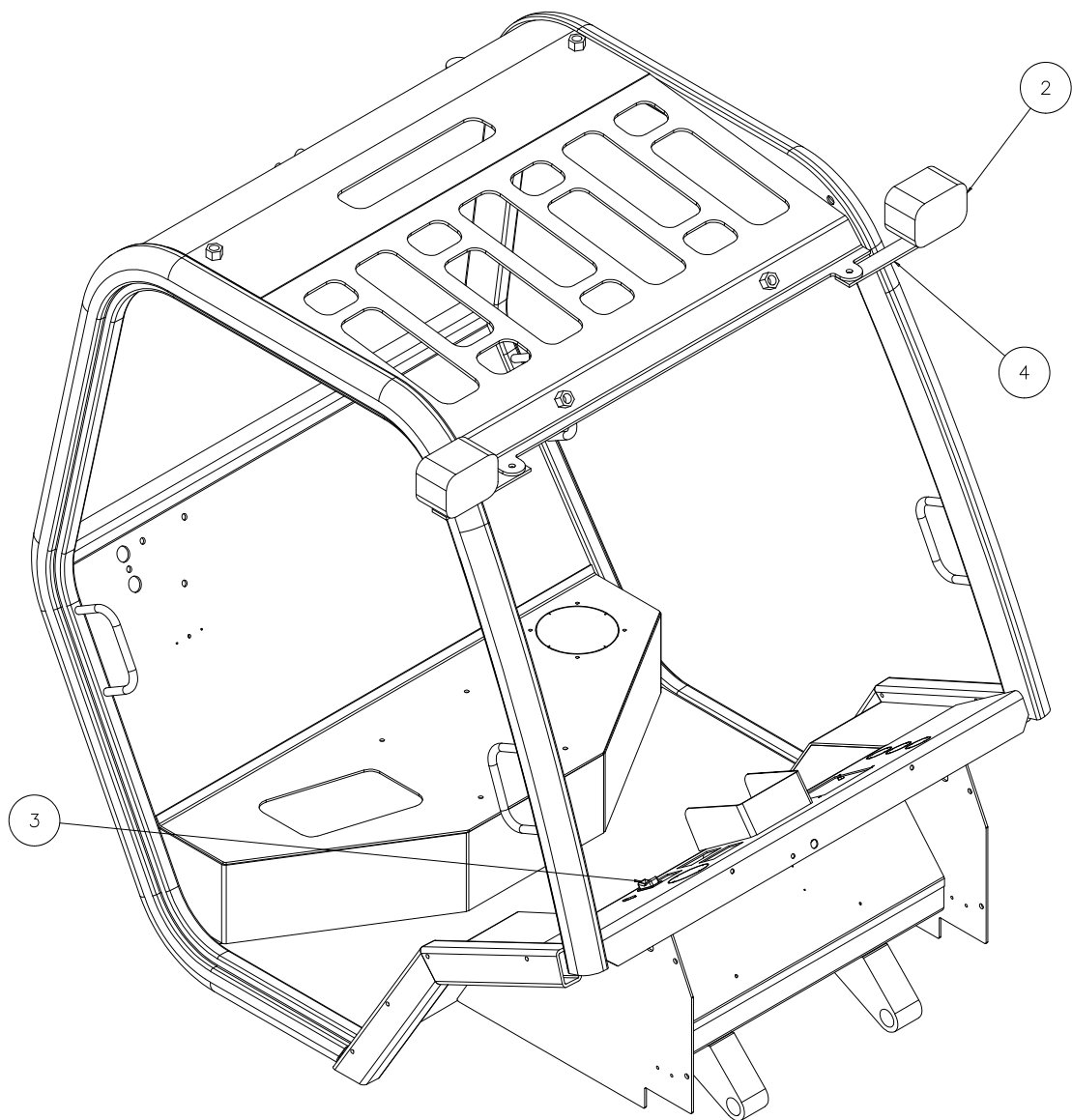

REPLACE 40 AMP BREAKER WITH 812097 50 AMP
DRILL BREAKER POSITION #20
IF ALL RED WIRES # 52 ON MAIN HARNESS ARE USED
CONNECT 10 AMP BREAKER TO WIRE # 2 & 3 AND CONNECT
OTHER END OF WIRE # 3 TO FUSED SIDE OF 50 AMP BREAKER.
IF WIRE # 52 ON MAIN HARNESS IS AVAILABLE USE JUMPER
FROM WIRE # 52 TO 10 AMP BREAKER WITH WIRE # 2. DO NOT
USE WIRE # 3
ON FULLY ENCLOSED CABS LIGHT WIRES RUN UP RH SIDE
ON MNA CABS RUN WIRES UP EACH SIDE
MOUNT LIGHT BRACKETS UNDER EXISTING WORK LIGHTS

1	ELECTRICAL, OVERHEAD WORK LIGHTS		QUANTITY / MODEL												11 BA 119			
			M30-4T	M40-4T	M50-4T		M30-4T H	M40-4T H	M50-4T H		M30-4T L	M40-4T L	M50-4T L		M30-4T HL	M40-4T HL	M50-4T HL	
ITEM	PART NO.	DESCRIPTION	M30-2T	M40-2T	M50-2T		M30-2T H	M40-2T H	M50-2T H		M30-2T L	M40-2T L	M50-2T L		M30-2T HL	M40-2T HL	M50-2T HL	
1	805888	Breaker, 10 amp	1	1	1	1	1	1	1	1	1	1	1	1	1	1	1	1
2	807514	Light, white	2	2	2	2	2	2	2	2	2	2	2	2	2	2	2	2
3	807667	Switch, light	1	1	1	1	1	1	1	1	1	1	1	1	1	1	1	1
4	807750	Bracket, light	2	2	2	2	2	2	2	2	2	2	2	2	2	2	2	2
5	807826	Jumper wire	1	1	1	1	1	1	1	1	1	1	1	1	1	1	1	1
6	812096	Harness	1	1	1	1	1	1	1	1	1	1	1	1	1	1	1	1
7	812097	Breaker, 50 amp	1	1	1	1	1	1	1	1	1	1	1	1	1	1	1	1
8	806341	Boot, breaker	1	1	1	1	1	1	1	1	1	1	1	1	1	1	1	1

11 BA 120

TIER III

ELECTRICAL, ROAD LIGHTING OPTION

M30-2T	M30-4T	M30-2T H	M30-4T H
M40-2T	M40-4T	M40-2T H	M40-4T H
M50-2T	M50-4T	M50-2T H	M50-4T H

M30-2T L	M30-4T L	M30-2T H L	M30-4T H L
M40-2T L	M40-4T L	M40-2T H L	M40-4T H L
M50-2T L	M50-4T L	M50-2T H L	M50-4T H L

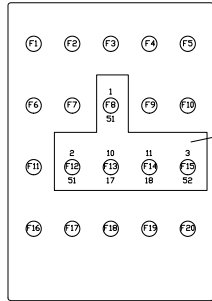

DRILL COVER POSITIONS 1,12,13,14 & 15 DIA 1/2"

F8 IS 15 AMP BREAKER USE JUMPER WIRES FROM MAIN HARNESS WIRE NUMBERS 51 & 52 TO BREAKER THE OTHER WIRE NUMBERS SHOWN ABOVE ARE PART OF THE ROAD LIGHT HARNESS

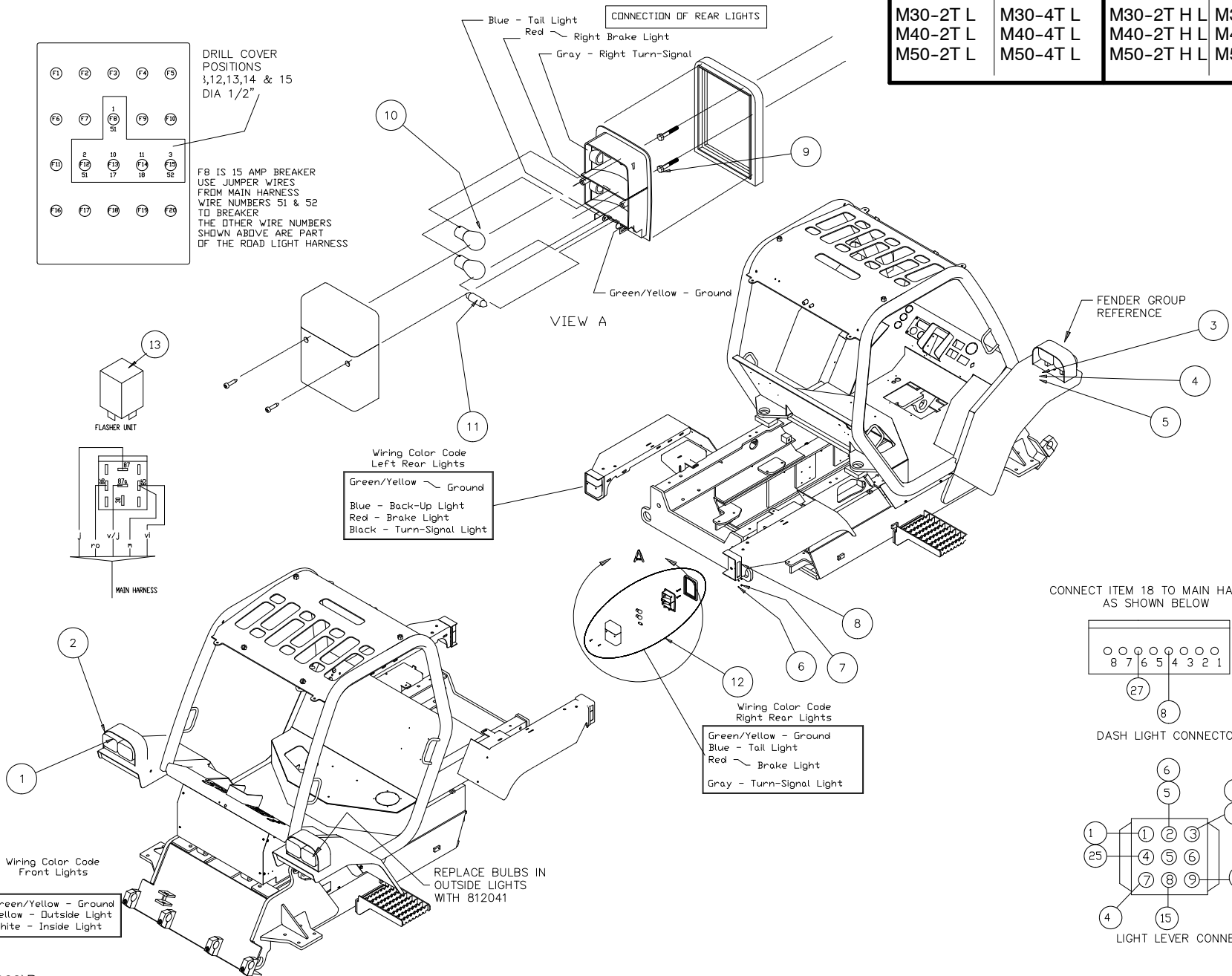
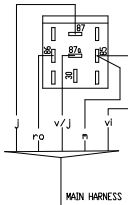
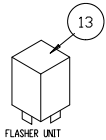

CONNECTION OF REAR LIGHTS

- Blue - Tail Light
- Red - Right Brake Light
- Gray - Right Turn-Signal

VIEW A

- Wiring Color Code Left Rear Lights
- Green/Yellow - Ground
 - Blue - Back-Up Light
 - Red - Brake Light
 - Black - Turn-Signal Light

- Wiring Color Code Right Rear Lights
- Green/Yellow - Ground
 - Blue - Tail Light
 - Red - Brake Light
 - Gray - Turn-Signal Light

- Wiring Color Code Front Lights
- Green/Yellow - Ground
 - Yellow - Outside Light
 - White - Inside Light

REPLACE BULBS IN OUTSIDE LIGHTS WITH 812041

CONNECT ITEM 18 TO MAIN HARNESS AS SHOWN BELOW

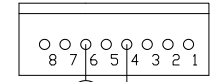

DASH LIGHT CONNECTOR

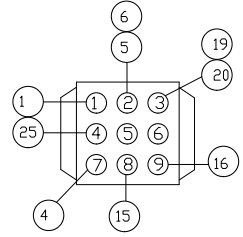

LIGHT LEVER CONNECTOR

1	ELECTRICAL, ROAD LIGHTING OPTION		QUANTITY / MODEL											11 BA 120			
			M30-4T	M40-4T	M50-4T		M30-4T H	M40-4T H	M50-4T H		M30-4T L	M40-4T L	M50-4T L		M30-4T HL	M40-4T HL	M50-4T HL
			M30-2T	M40-2T	M50-2T		M30-2T H	M40-2T H	M50-2T H		M30-2T L	M40-2T L	M50-2T L		M30-2T HL	M40-2T HL	M50-2T HL
ITEM	PART NO.	DESCRIPTION	M30-2T	M40-2T	M50-2T		M30-2T H	M40-2T H	M50-2T H		M30-2T L	M40-2T L	M50-2T L		M30-2T HL	M40-2T HL	M50-2T HL
1	807514	Light, white	4	4	4	4	4	4	4	4	4	4	4	4	4	4	4
2	496680	Guard, headlight (without lights)	2	2	2	2	2	2	2	2	2	2	2	2	2	2	2
3	B3698-8	Clamp	4	4	4	4	4	4	4	4	4	4	4	4	4	4	4
4	174132	Washer, lock	4	4	4	4	4	4	4	4	4	4	4	4	4	4	4
5	25714	Nut	4	4	4	4	4	4	4	4	4	4	4	4	4	4	4
6	192310	Washer, lock	4	4	4	4	4	4	4	4	4	4	4	4	4	4	4
7	54232	Nut	4	4	4	4	4	4	4	4	4	4	4	4	4	4	4
8	219533	Tail light bracket	2	2	2	2	2	2	2	2	2	2	2	2	2	2	2
9	58523	Bolt	4	4	4	4	4	4	4	4	4	4	4	4	4	4	4
10	675	Bulb, 21W	4	4	4	4	4	4	4	4	4	4	4	4	4	4	4
11	676	Bulb, 5W	2	2	2	2	2	2	2	2	2	2	2	2	2	2	2
12	2163	Tail light assembly	2	2	2	2	2	2	2	2	2	2	2	2	2	2	2
13	169917	Flasher unit	1	1	1	1	1	1	1	1	1	1	1	1	1	1	1
15	805888	Circuit breaker, 10 amp	4	4	4	4	4	4	4	4	4	4	4	4	4	4	4
16	805973	Circuit breaker, 15 A	1	1	1	1	1	1	1	1	1	1	1	1	1	1	1
17	806341	Boot, breaker	5	5	5	5	5	5	5	5	5	5	5	5	5	5	5
18	807871	Harness, road lights	1	1	1	1	1	1	1	1	1	1	1	1	1	1	1
19	807872	Switch, warning	1	1	1	1	1	1	1	1	1	1	1	1	1	1	1
20	807826	Jumper wire	3	3	3	3	3	3	3	3	3	3	3	3	3	3	3
21	812041	Bulb. 35 w	2	2	2	2	2	2	2	2	2	2	2	2	2	2	2

11 BA 121
TIER III

ELECTRICAL, POULTRY/BACK DOCK LIGHTING OPTION

M30-2T	M30-4T	M30-2T H	M30-4T H
M40-2T	M40-4T	M40-2T H	M40-4T H
M50-2T	M50-4T	M50-2T H	M50-4T H
M30-2T L	M30-4T L	M30-2T H L	M30-4T H L
M40-2T L	M40-4T L	M40-2T H L	M40-4T H L
M50-2T L	M50-4T L	M50-2T H L	M50-4T H L

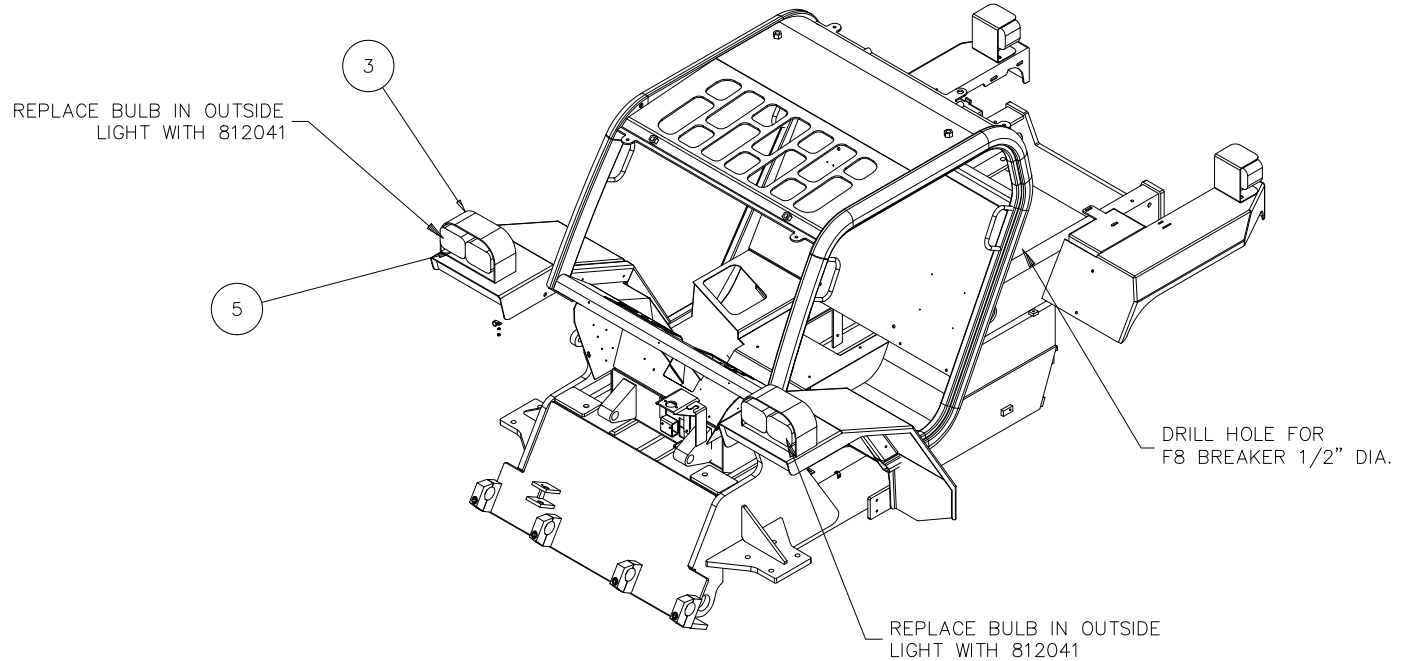
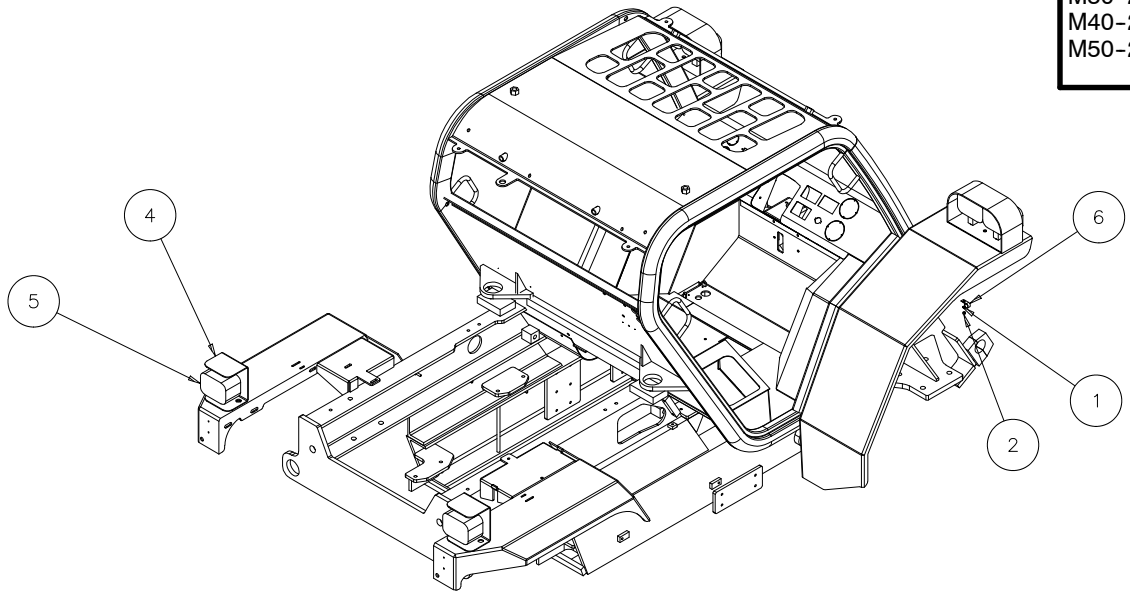

1	ELECTRICAL, POULTRY/BACK DOCK LIGHTING OPTION		QUANTITY / MODEL												11 BA 121		
			M30-4T	M40-4T	M50-4T		M30-4T H	M40-4T H	M50-4T H		M30-4T L	M40-4T L	M50-4T L		M30-4T HL	M40-4T HL	M50-4T HL
ITEM	PART NO.	DESCRIPTION	M30-2T	M40-2T	M50-2T		M30-2T H	M40-2T H	M50-2T H		M30-2T L	M40-2T L	M50-2T L		M30-2T HL	M40-2T HL	M50-2T HL
1	174132	Washer, lock	4	4	4	4	4	4	4	4	4	4	4	4	4	4	4
2	25714	Nut	4	4	4	4	4	4	4	4	4	4	4	4	4	4	4
3	496680	Guard (without lamps)	2	2	2	2	2	2	2	2	2	2	2	2	2	2	2
4	805683	Bracket, rear poultry light	2	2	2	2	2	2	2	2	2	2	2	2	2	2	2
5	807514	Light, white work	6	6	6	6	6	6	6	6	6	6	6	6	6	6	6
6	B3698-8	Clamp	4	4	4	4	4	4	4	4	4	4	4	4	4	4	4
7	807511	Switch	1	1	1	1	1	1	1	1	1	1	1	1	1	1	1
8	807929	Harness, main hawk	1	1	1	1	1	1	1	1	1	1	1	1	1	1	1
9	812041	Bulb, 35 w	1	1	1	1	1	1	1	1	1	1	1	1	1	1	1
10	805887	Breaker, 20 amp	1	1	1	1	1	1	1	1	1	1	1	1	1	1	1
11	806341	Boot, breaker	1	1	1	1	1	1	1	1	1	1	1	1	1	1	1

70.00

11 BA 122
TIER III

ELECTRICAL, WARNING BEACON OPTION

M30-2T	M30-4T	M30-2T H	M30-4T H
M40-2T	M40-4T	M40-2T H	M40-4T H
M50-2T	M50-4T	M50-2T H	M50-4T H
M30-2T L	M30-4T L	M30-2T H L	M30-4T H L
M40-2T L	M40-4T L	M40-2T H L	M40-4T H L
M50-2T L	M50-4T L	M50-2T H L	M50-4T H L

USED ONLY ON FULLY ENCLOSED CABS

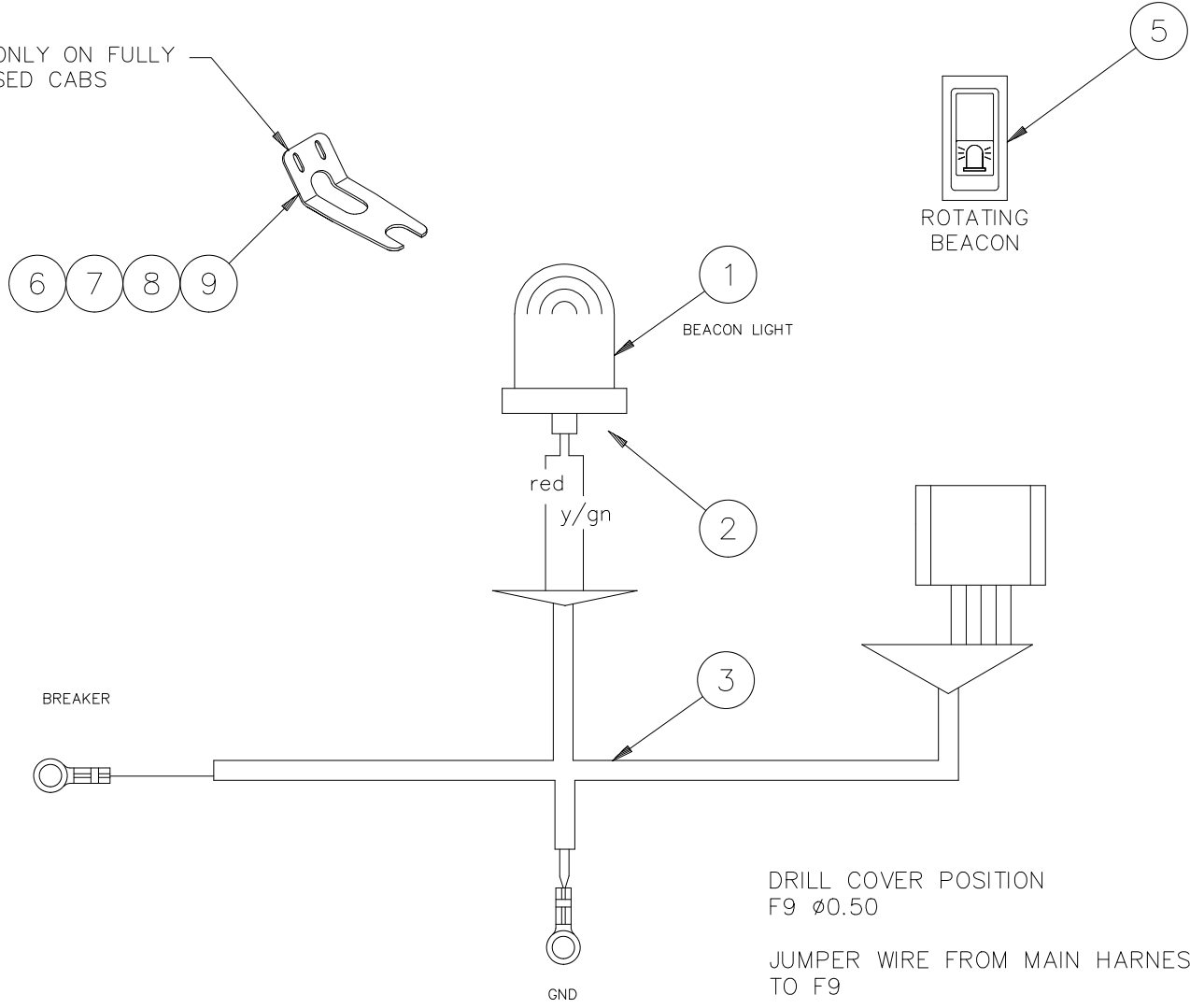

1	ELECTRICAL, WARNING BEACON OPTION		QUANTITY / MODEL											11 BA 122			
			M30-4T	M40-4T	M50-4T		M30-4T H	M40-4T H	M50-4T H		M30-4T L	M40-4T L	M50-4T L		M30-4T HL	M40-4T HL	M50-4T HL
ITEM	PART NO.	DESCRIPTION	M30-2T	M40-2T	M50-2T		M30-2T H	M40-2T H	M50-2T H		M30-2T L	M40-2T L	M50-2T L		M30-2T HL	M40-2T HL	M50-2T HL
1	224759	Rotating beacon	1	1	1	1	1	1	1	1	1	1	1	1	1	1	1
2	192415	Mounting kit (post)	1	1	1	1	1	1	1	1	1	1	1	1	1	1	1
3	807854	Harness	1	1	1	1	1	1	1	1	1	1	1	1	1	1	1
4	805888	Circuit breaker, 10 amp	1	1	1	1	1	1	1	1	1	1	1	1	1	1	1
5	807853	Switch, beacon	1	1	1	1	1	1	1	1	1	1	1	1	1	1	1
6	231403	Plate, beacon mount	1	1	1	1	1	1	1	1	1	1	1	1	1	1	1
7	25713	Screw	2	2	2	2	2	2	2	2	2	2	2	2	2	2	2
8	189857	Washer	2	2	2	2	2	2	2	2	2	2	2	2	2	2	2
9	25714	Nut	2	2	2	2	2	2	2	2	2	2	2	2	2	2	2
10	807826	Jumper wire	1	1	1	1	1	1	1	1	1	1	1	1	1	1	1
11	806341	Boot, breaker	1	1	1	1	1	1	1	1	1	1	1	1	1	1	1

11 CC 189
TIER III

CAB WIRING HARNESS, 77, 81, & 100 IN.
(WACO BUILT CABS ONLY)

M30-2T	M30-4T	M30-2T H	M30-4T H
M40-2T	M40-4T	M40-2T H	M40-4T H
M50-2T	M50-4T	M50-2T H	M50-4T H
M30-2T L	M30-4T L	M30-2T H L	M30-4T H L
M40-2T L	M40-4T L	M40-2T H L	M40-4T H L
M50-2T L	M50-4T L	M50-2T H L	M50-4T H L

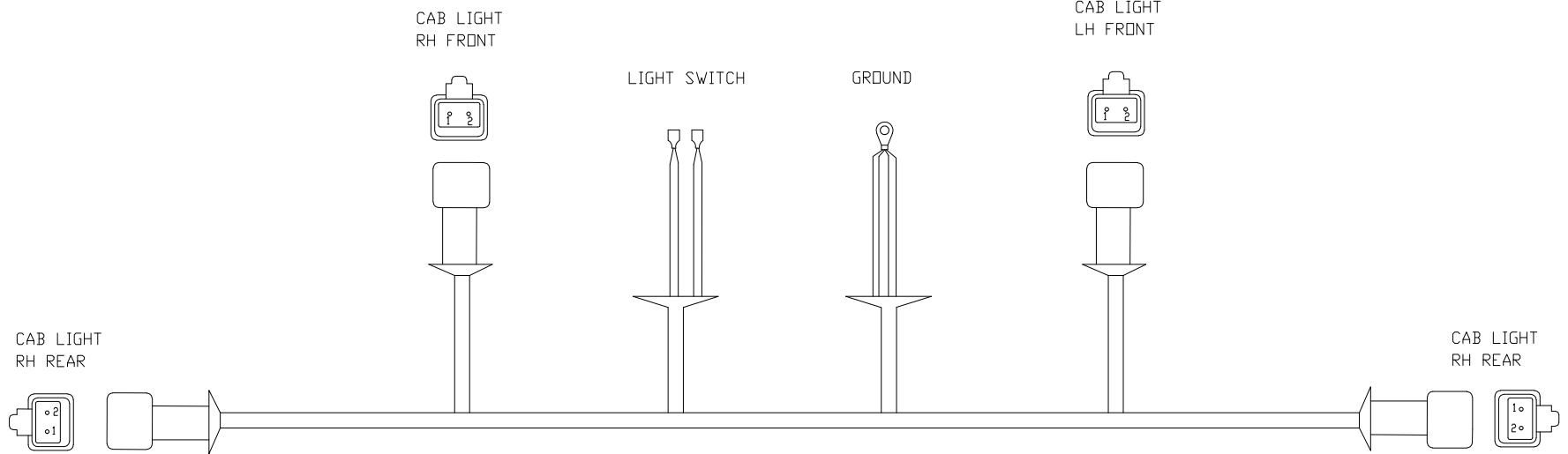

ITEM	PART NO.	DESCRIPTION	QUANTITY / MODEL												11 CC 189			
			M30-2T	M40-2T	M50-2T		M30-2T H	M40-2T H	M50-2T H		M30-4T L	M40-4T L	M50-4T L		M30-4T HL	M40-4T HL	M50-4T HL	
1	807723	Harness, cab	1	1	1	1	1	1	1	1	1	1	1	1	1	1	1	1

CAB WIRING HARNESS, 77, 81, & 100 IN.
(WACO BUILT CABS ONLY)

11 CC 225
TIER III

WINDSHIELD WIPER INSTALLATION, 100 IN. CAB (CAB 807376)

M30-2T	M30-4T	M30-2T H	M30-4T H
M40-2T	M40-4T	M40-2T H	M40-4T H
M50-2T	M50-4T	M50-2T H	M50-4T H
M30-2T L	M30-4T L	M30-2T H L	M30-4T H L
M40-2T L	M40-4T L	M40-2T H L	M40-4T H L
M50-2T L	M50-4T L	M50-2T H L	M50-4T H L

APPLY DI-ELECTRIC GREASE TO ALL ELECTRICAL CONNECTIONS

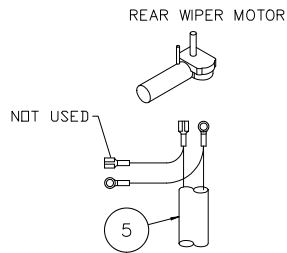
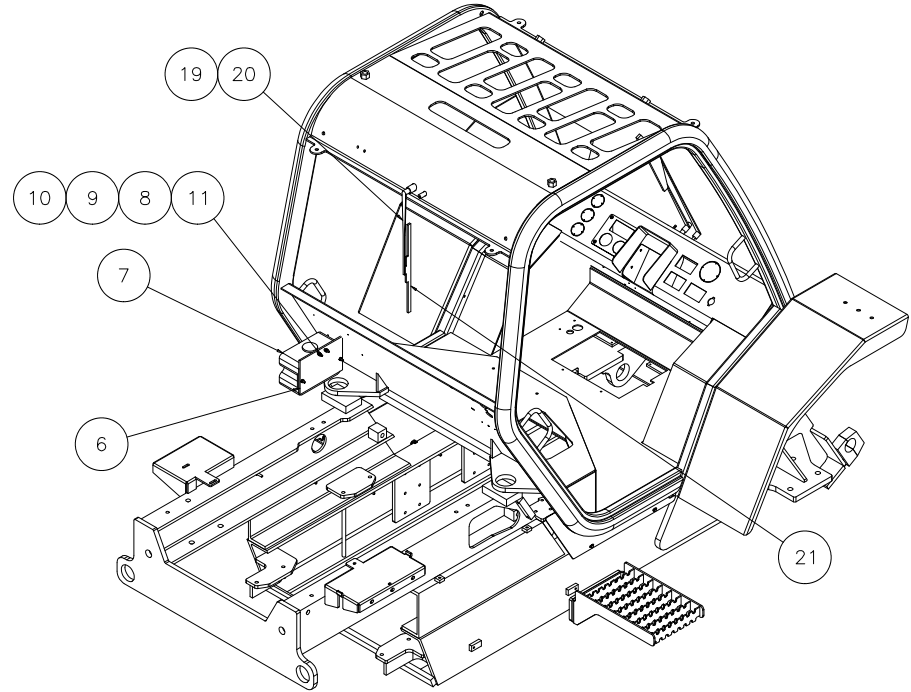
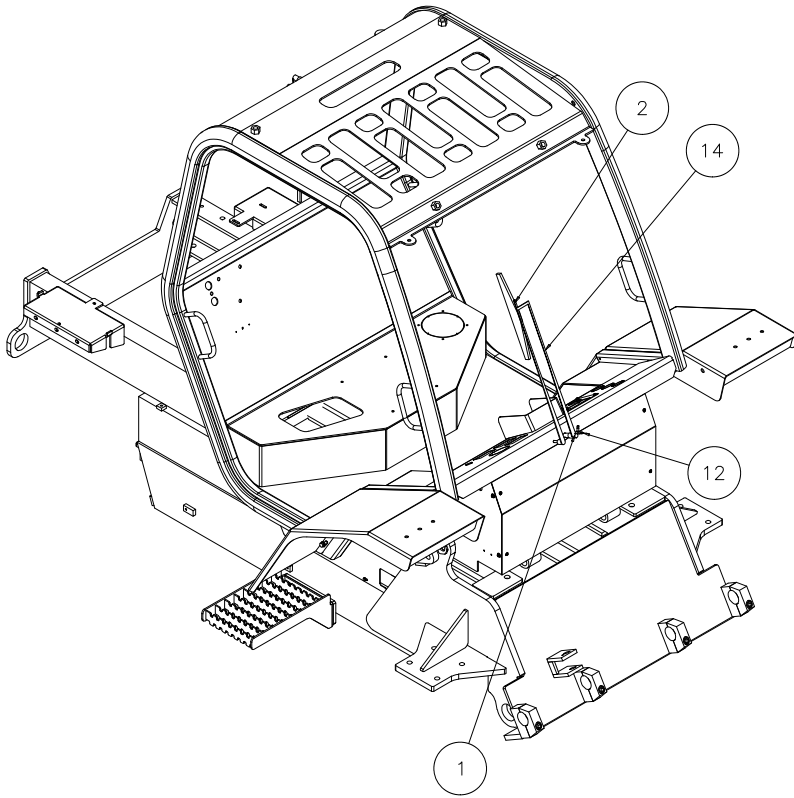

FRONT WIPER MOTOR CONNECTS TO
PLUG ON WIPER HARNESS

DRILL COVER POSITION
F16 & F17 $\phi 0.50$

JUMPER WIRE FROM MAIN HARNESS
TO F16 TO F17

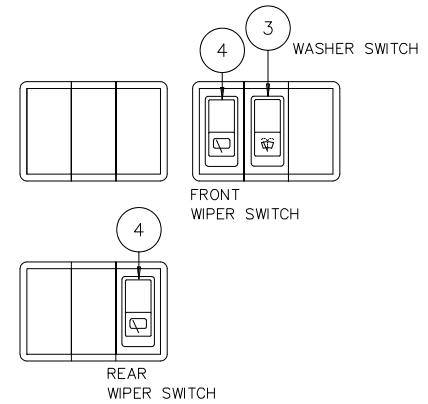

1	WINDSHIELD WIPER INSTALLATION, 100 IN. CAB (CAB 802656)		QUANTITY / MODEL											11 CC 225			
			M30-4T	M40-4T	M50-4T		M30-4T H	M40-4T H	M50-4T H		M30-4T L	M40-4T L	M50-4T L		M30-4T HL	M40-4T HL	M50-4T HL
ITEM	PART NO.	DESCRIPTION	M30-2T	M40-2T	M50-2T		M30-2T H	M40-2T H	M50-2T H		M30-2T L	M40-2T L	M50-2T L		M30-2T HL	M40-2T HL	M50-2T HL
	807840	Windshield wiper installation	1	1	1	1	1	1	1	1	1	1	1	1	1	1	1
1	803168	Motor, wiper	1	1	1	1	1	1	1	1	1	1	1	1	1	1	1
2	803202	Wiper blade	1	1	1	1	1	1	1	1	1	1	1	1	1	1	1
3	807170	Switch	1	1	1	1	1	1	1	1	1	1	1	1	1	1	1
4	805904	Switch	1	1	1	1	1	1	1	1	1	1	1	1	1	1	1
5	807824	Harness, wiper	1	1	1	1	1	1	1	1	1	1	1	1	1	1	1
6	805937	Bracket	1	1	1	1	1	1	1	1	1	1	1	1	1	1	1
7	805936	Washer bottle	1	1	1	1	1	1	1	1	1	1	1	1	1	1	1
8	29469	Washer	4	4	4	4	4	4	4	4	4	4	4	4	4	4	4
9	42316	Washer	4	4	4	4	4	4	4	4	4	4	4	4	4	4	4
10	25714	Nut	4	4	4	4	4	4	4	4	4	4	4	4	4	4	4
11	168343	Bolt	4	4	4	4	4	4	4	4	4	4	4	4	4	4	4
12	805938	Fitting	1	1	1	1	1	1	1	1	1	1	1	1	1	1	1
13	805939	Hose	1	1	1	1	1	1	1	1	1	1	1	1	1	1	1
14	803169	Wiper arm	1	1	1	1	1	1	1	1	1	1	1	1	1	1	1
15	806341	Boot, breaker	1	1	1	1	1	1	1	1	1	1	1	1	1	1	1
17	805888	Circuit breaker, 10 amp	2	2	2	2	2	2	2	2	2	2	2	2	2	2	2
18	807826	Jumper wire	2	2	2	2	2	2	2	2	2	2	2	2	2	2	2
19	552760	Motor, wiper	1	1	1	1	1	1	1	1	1	1	1	1	1	1	1
20	184526	Wiper arm	1	1	1	1	1	1	1	1	1	1	1	1	1	1	1
21	54557	Wiper blade	1	1	1	1	1	1	1	1	1	1	1	1	1	1	1

11 CC 226
TIER III

WINDSHIELD WIPER INSTALLATION, 77 & 81 IN. CAB

M30-2T	M30-4T	M30-2T H	M30-4T H
M40-2T	M40-4T	M40-2T H	M40-4T H
M50-2T	M50-4T	M50-2T H	M50-4T H
M30-2T L	M30-4T L	M30-2T H L	M30-4T H L
M40-2T L	M40-4T L	M40-2T H L	M40-4T H L
M50-2T L	M50-4T L	M50-2T H L	M50-4T H L

APPLY DI-ELECTRIC GREASE TO ALL ELECTRICAL CONNECTIONS

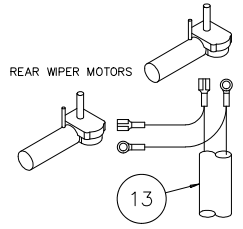
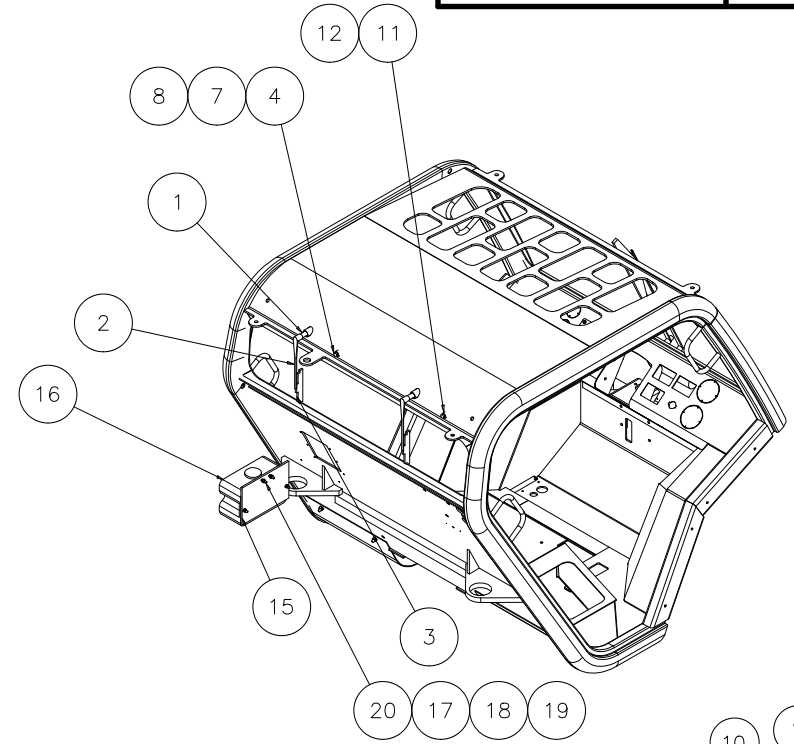
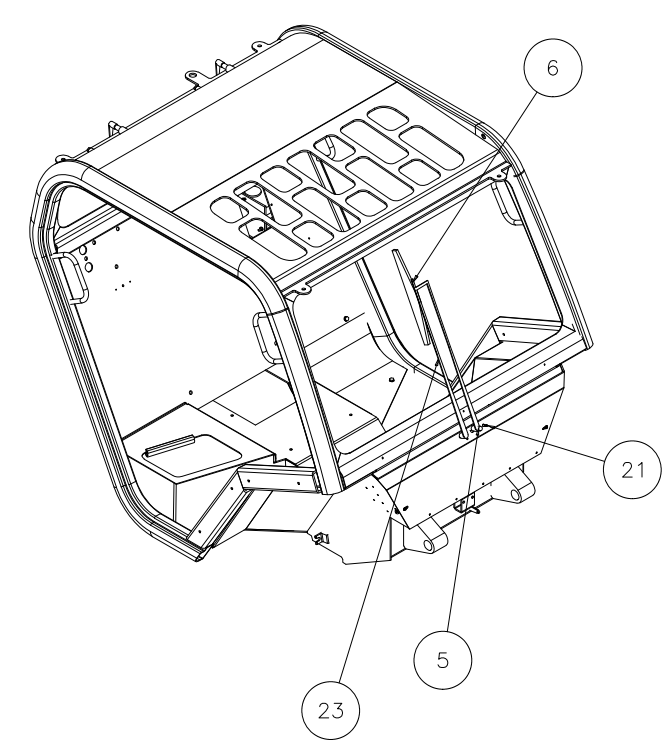

NOTE: SET REAR MOTORS TO 85°/65°

FRONT WIPER MOTOR CONNECTS TO PLUG ON WIPER HARNESS

DRILL COVER POSITION
F16 & F17 \varnothing 0.50

JUMPER WIRE FROM MAIN HARNESS
TO F16 TO F17

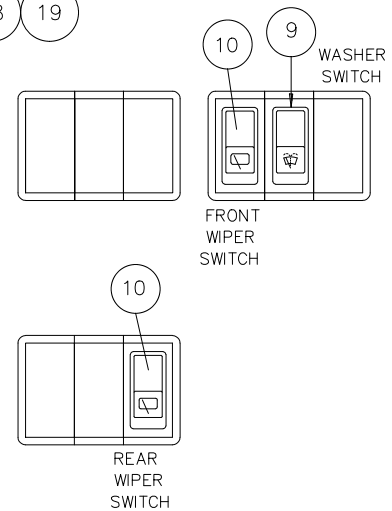

1	WINDSHIELD WIPER INSTALLATION, 77 & 81 IN. CAB		QUANTITY / MODEL											11 CC 226				
			M30-4T	M40-4T	M50-4T		M30-4T H	M40-4T H	M50-4T H		M30-4T L	M40-4T L	M50-4T L		M30-4T HL	M40-4T HL	M50-4T HL	
ITEM	PART NO.	DESCRIPTION	M30-2T	M40-2T	M50-2T		M30-2T H	M40-2T H	M50-2T H		M30-2T L	M40-2T L	M50-2T L		M30-2T HL	M40-2T HL	M50-2T HL	
	807822	Windshield wiper kit, front and rear	1	1	1	1	1	1	1	1	1	1	1	1	1	1	1	1
1	491718	Motor, wiper	2	2	2	2	2	2	2	2	2	2	2	2	2	2	2	2
2	803208	Wiper arm	2	2	2	2	2	2	2	2	2	2	2	2	2	2	2	2
3	803209	Wiper blade	2	2	2	2	2	2	2	2	2	2	2	2	2	2	2	2
4	58531	Bolt	2	2	2	2	2	2	2	2	2	2	2	2	2	2	2	2
5	803168	Wiper motor	1	1	1	1	1	1	1	1	1	1	1	1	1	1	1	1
6	803202	Wiper blade	1	1	1	1	1	1	1	1	1	1	1	1	1	1	1	1
7	61674	Washer, flat	4	4	4	4	4	4	4	4	4	4	4	4	4	4	4	4
8	58528	Nut	2	2	2	2	2	2	2	2	2	2	2	2	2	2	2	2
9	807170	Switch	1	1	1	1	1	1	1	1	1	1	1	1	1	1	1	1
10	805904	Switch	2	2	2	2	2	2	2	2	2	2	2	2	2	2	2	2
11	804024	Spacer	2	2	2	2	2	2	2	2	2	2	2	2	2	2	2	2
12	804025	Spacer	2	2	2	2	2	2	2	2	2	2	2	2	2	2	2	2
13	807824	Harness, wiper	1	1	1	1	1	1	1	1	1	1	1	1	1	1	1	1
14	805905	Jumper wire	1	1	1	1	1	1	1	1	1	1	1	1	1	1	1	1
15	805937	Bracket	1	1	1	1	1	1	1	1	1	1	1	1	1	1	1	1
16	805936	Washer bottle	1	1	1	1	1	1	1	1	1	1	1	1	1	1	1	1
17	29469	Washer	4	4	4	4	4	4	4	4	4	4	4	4	4	4	4	4
18	42316	Washer	4	4	4	4	4	4	4	4	4	4	4	4	4	4	4	4
19	25714	Nut	4	4	4	4	4	4	4	4	4	4	4	4	4	4	4	4
20	168343	Bolt	4	4	4	4	4	4	4	4	4	4	4	4	4	4	4	4
21	805938	Fitting	1	1	1	1	1	1	1	1	1	1	1	1	1	1	1	1
22	805939	Hose	1	1	1	1	1	1	1	1	1	1	1	1	1	1	1	1
23	803169	Wiper arm	1	1	1	1	1	1	1	1	1	1	1	1	1	1	1	1
24	806341	Boot, breaker	2	2	2	2	2	2	2	2	2	2	2	2	2	2	2	2
26	805888	Circuit breaker, 10 amp	2	2	2	2	2	2	2	2	2	2	2	2	2	2	2	2
27	807826	Jumper wire	2	2	2	2	2	2	2	2	2	2	2	2	2	2	2	2

74.00

11 CC 228

TIER III

GAUGES, OIL TEMP, OIL PRESS, WATER TEMP

M30-2T	M30-4T	M30-2T H	M30-4T H
M40-2T	M40-4T	M40-2T H	M40-4T H
M50-2T	M50-4T	M50-2T H	M50-4T H
M30-2T L	M30-4T L	M30-2T H L	M30-4T H L
M40-2T L	M40-4T L	M40-2T H L	M40-4T H L
M50-2T L	M50-4T L	M50-2T H L	M50-4T H L

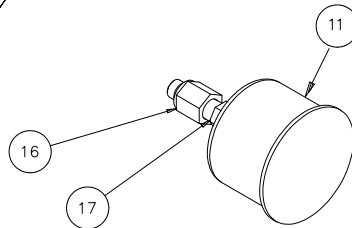
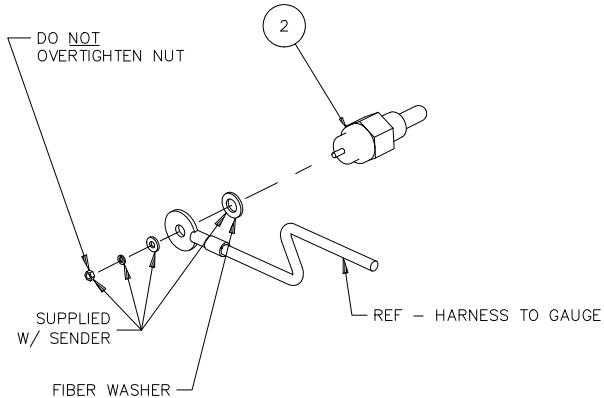
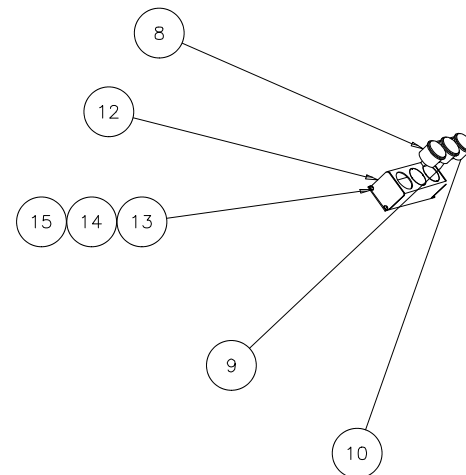
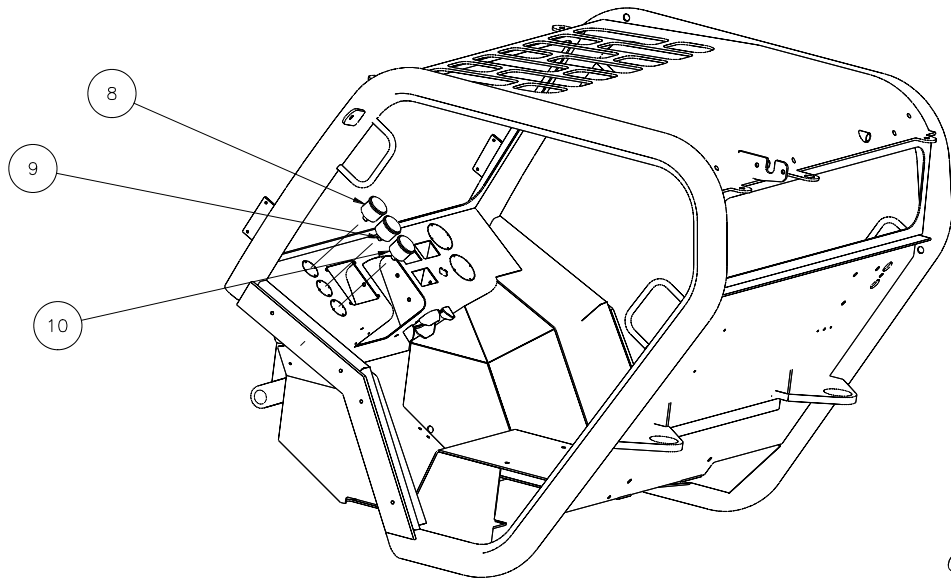

DRILL COVER POSITION F10 Ø0.50
INSTALL JUMPER WIRE FROM MAIN
HARNESS TO F10 BREAKER

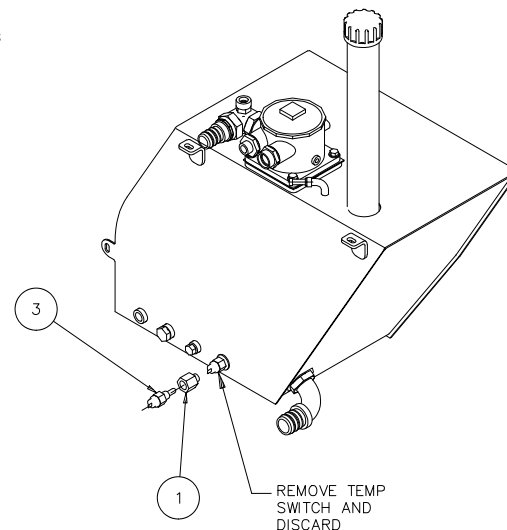
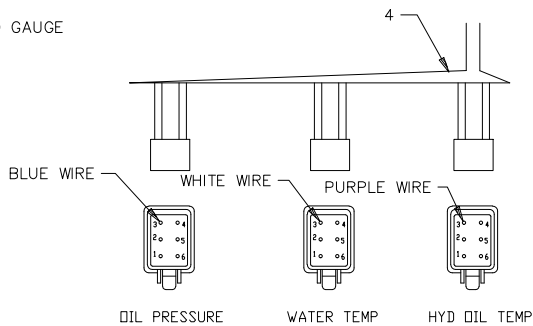

1	QUANTITY / MODEL												11 CC 228										
	GAUGES, OIL TEMP, OIL PRESS, WATER TEMP												M30-4T	M40-4T	M50-4T	M30-4T H	M40-4T H	M50-4T H	M30-4T L	M40-4T L	M50-4T L	M30-4T HL	M40-4T HL
ITEM	PART NO.	DESCRIPTION	M30-2T	M40-2T	M50-2T		M30-2T H	M40-2T H	M50-2T H		M30-2T L	M40-2T L	M50-2T L		M30-2T HL	M40-2T HL	M50-2T HL						
1	803412	Adapter	1	1	1	1	1	1	1	1	1	1	1	1	1	1	1	1	1				
2	805145	Sender, water temp	1	1	1	1	1	1	1	1	1	1	1	1	1	1	1	1	1				
3	423309	Sender, oil temp	1	1	1	1	1	1	1	1	1	1	1	1	1	1	1	1	1				
4	807878	Harness, gauges	1	1	1	1	1	1	1	1	1	1	1	1	1	1	1	1	1				
5	805888	Circuit breaker, 10 amp	1	1	1	1	1	1	1	1	1	1	1	1	1	1	1	1	1				
6	806341	Boot, breaker	1	1	1	1	1	1	1	1	1	1	1	1	1	1	1	1	1				
7	807826	Jumper wire	1	1	1	1	1	1	1	1	1	1	1	1	1	1	1	1	1				
8	807879	Gauge, water temp	1	1	1	1	1	1	1	1	1	1	1	1	1	1	1	1	1				
9	807880	Gauge, oil pressure	1	1	1	1	1	1	1	1	1	1	1	1	1	1	1	1	1				
10	807881	Gauge, oil temp	1	1	1	1	1	1	1	1	1	1	1	1	1	1	1	1	1				
11	807882	Sender, oil pressure	1	1	1	1	1	1	1	1	1	1	1	1	1	1	1	1	1				
12*	803399	Guage panel	1	1	1	1	1	1	1	1	1	1	1	1	1	1	1	1	1				
13*	29469	Washer, flat	4	4	4	4	4	4	4	4	4	4	4	4	4	4	4	4	4				
14*	189172	Screw	4	4	4	4	4	4	4	4	4	4	4	4	4	4	4	4	4				
15*	25714	Nut	4	4	4	4	4	4	4	4	4	4	4	4	4	4	4	4	4				
16	805791	Adapter	1	1	1	1	1	1	1	1	1	1	1	1	1	1	1	1	1				
17	K247-4-2	Bushing	1	1	1	1	1	1	1	1	1	1	1	1	1	1	1	1	1				

* For use with 100 inch fully enclosed cabs only

11 CD 134
TIER III

ENGINE SHUTDOWN KIT (OPTIONAL)

M30-2T	M30-4T	M30-2T H	M30-4T H
M40-2T	M40-4T	M40-2T H	M40-4T H
M50-2T	M50-4T	M50-2T H	M50-4T H
M30-2T L	M30-4T L	M30-2T H L	M30-4T H L
M40-2T L	M40-4T L	M40-2T H L	M40-4T H L
M50-2T L	M50-4T L	M50-2T H L	M50-4T H L

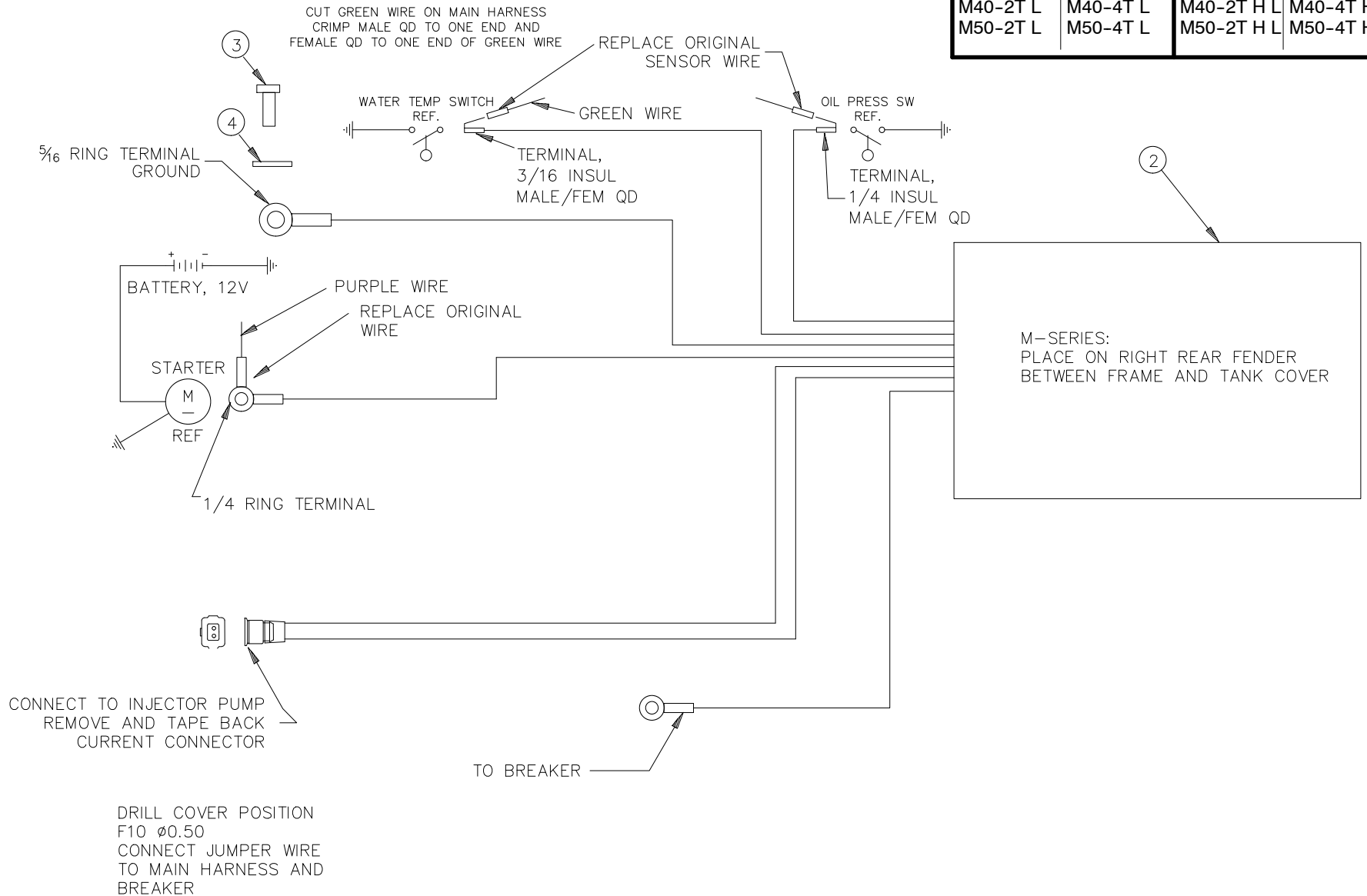

1	ENGINE SHUTDOWN KIT (OPTIONAL)		QUANTITY / MODEL												11 CD 134			
			M30-4T	M40-4T	M50-4T		M30-4T H	M40-4T H	M50-4T H		M30-4T L	M40-4T L	M50-4T L		M30-4T HL	M40-4T HL	M50-4T HL	
ITEM	PART NO.	DESCRIPTION	M30-2T	M40-2T	M50-2T		M30-2T H	M40-2T H	M50-2T H		M30-2T L	M40-2T L	M50-2T L		M30-2T HL	M40-2T HL	M50-2T HL	
1	805889	Circuit breaker, 5 amp	1	1	1	1	1	1	1	1	1	1	1	1	1	1	1	1
2	807918	Shut down module	1	1	1	1	1	1	1	1	1	1	1	1	1	1	1	1
3	54951	Bolt	1	1	1	1	1	1	1	1	1	1	1	1	1	1	1	1
4	61674	Washer, flat	1	1	1	1	1	1	1	1	1	1	1	1	1	1	1	1
5	79533	Screw	4	4	4	4	4	4	4	4	4	4	4	4	4	4	4	4
6	192310	Washer, lock	4	4	4	4	4	4	4	4	4	4	4	4	4	4	4	4
7	54232	Nut	4	4	4	4	4	4	4	4	4	4	4	4	4	4	4	4
8	806341	Boot, breaker	1	1	1	1	1	1	1	1	1	1	1	1	1	1	1	1
9	807826	Jumper wire	1	1	1	1	1	1	1	1	1	1	1	1	1	1	1	1

11 CD 135
TIER III

HYDROSTATIC GEARBOX SOLENOID HARNESS

M30-2T H	M30-4T H
M40-2T H	M40-4T H
M50-2T H	M50-4T H

M30-2T H L	M30-4T H L
M40-2T H L	M40-4T H L
M50-2T H L	M50-4T H L

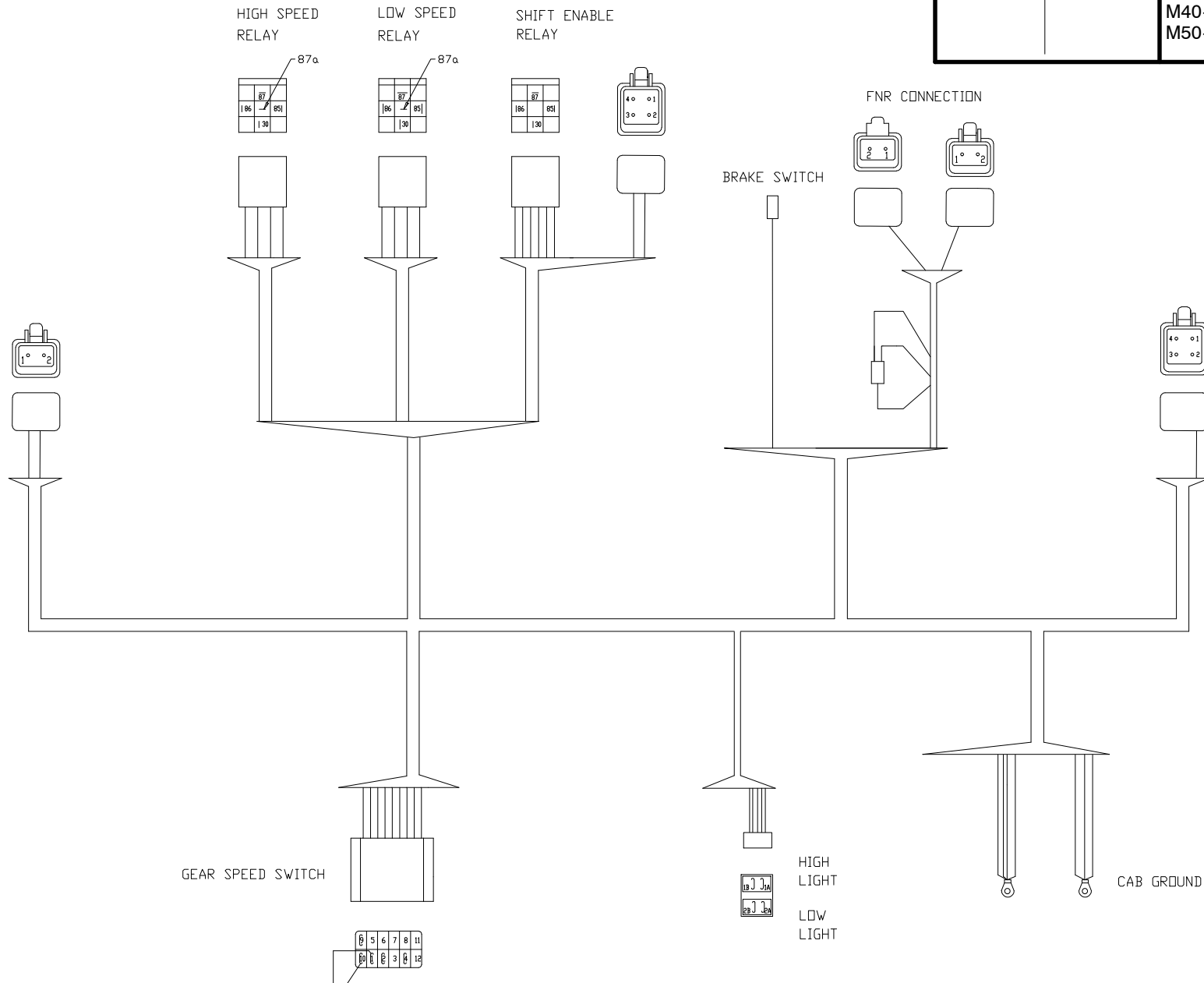

			QUANTITY / MODEL								11 CD 135						
							M30-4T H	M40-4T H	M50-4T H						M30-4T HL	M40-4T HL	M50-4T HL
ITEM	PART NO.	DESCRIPTION				M30-2T H	M40-2T H	M50-2T H						M30-2T HL	M40-2T HL	M50-2T HL	
1		HYDROSTATIC GEARBOX SOLENOID HARNESS															
	807662	Wire harness, hydrostatic gearbox solenoid				1	1	1	1					1	1	1	1

11 CD 129
Tier III

OIL COOLER, DRIVE AXLE, TORQUE CONVERTER OPTION

M 30-2T	M 30-4T		
M 40-2T	M 40-4T		
M 50-2T	M 50-4T		
M 30-2T	M 30-4T		
M 40-2T	M 40-4T		
M 50-2T	M 50-4T		

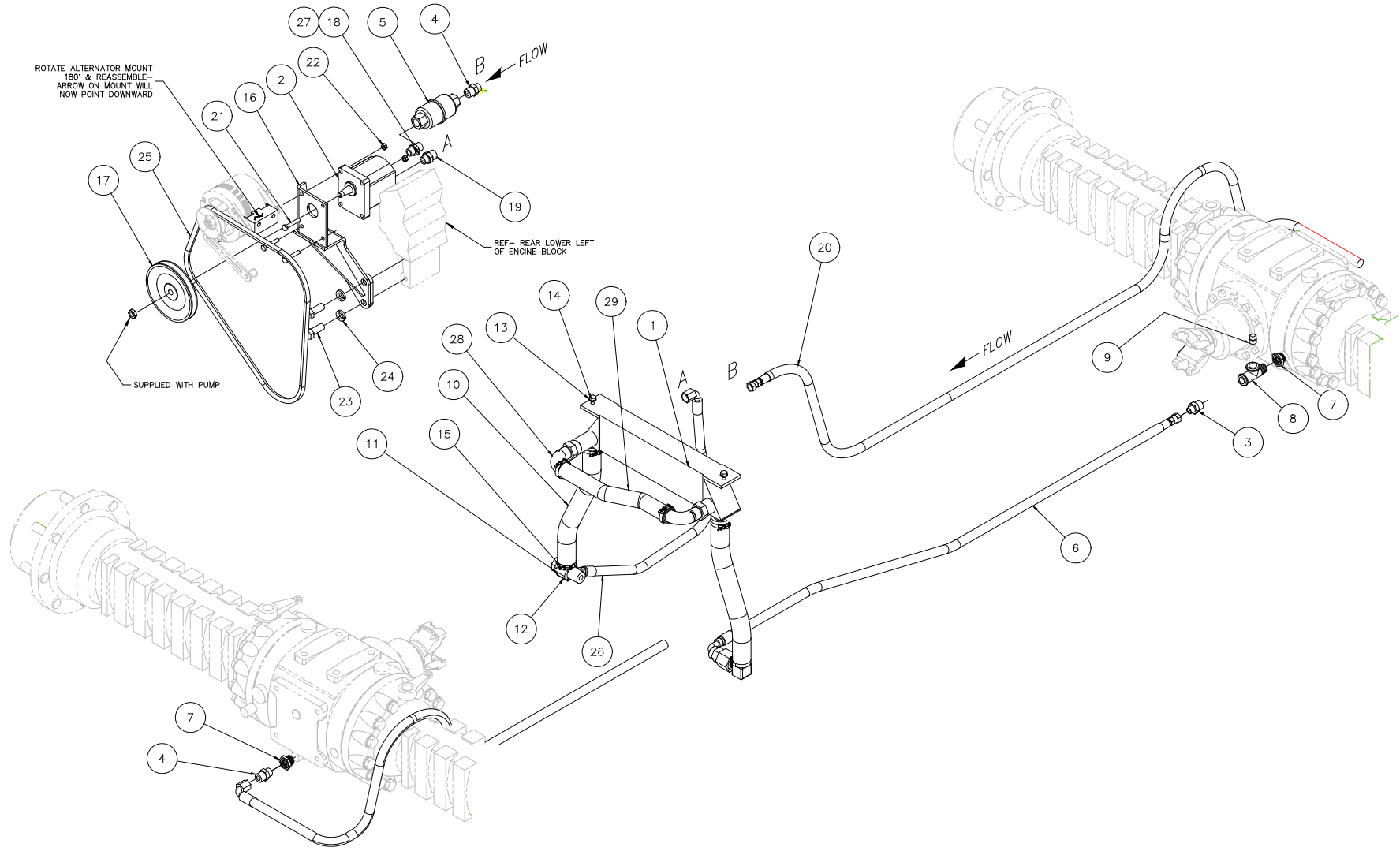

			QUANTITY / MODEL				11 CD 129					
1	OIL COOLER, DRIVE AXLE, TORQUE CONVERTER OPTION		M 30-4 T	M 40-4 T	M 50-4 T			M 30-4 TL	M 40-4 TL	M 50-4 TL		
ITEM	PART NO.	DESCRIPTION	M 30-2 T	M 40-2 T	M 50-2 T			M 30-2 TL	M 40-2 TL	M 50-2 TL		
1	812481	Oil Cooler	1	1	1			1	1	1		
2	244242	Pump .89CU IN/REV	1	1	1			1	1	1		
3	425495	Adapter, 8-FLO-S	1	1	1			1	1	1		
4	425494	Adapter, Parker 8-8-FL0-5	2	2	2			2	2	2		
5	425481	Filter, Flo Ezy Oil 10L-04-238	1	1	1			1	1	1		
6	804600	Hose Assy.	1	1	1			1	1	1		
7	425493	Adapter, MMTFP221538	2	2	2			2	2	2		
8	K224-6	Tee	1	1	1			1	1	1		
9	B114A3	Plug, 3/8 NPT Pipe	1	1	1			1	1	1		
10	804597	Hose	2	2	2			2	2	2		
11	803409	Hose Insert, 1"NPT-1-1/4" Bead	2	2	2			2	2	2		
12	804598	Adapter	2	2	2			2	2	2		
13	K34807	Washer, 3/8 Lock	2	2	2			2	2	2		
14	K20388	Bolt, 3/8 x 1	2	2	2			2	2	2		
15	804776	Clamp	6	6	6			6	6	6		
16	804707	Pump Mount Bracket	1	1	1			1	1	1		
17	244289	Pully 1/2 Groove	1	1	1			1	1	1		
18	804808	Adapter 3/4 BSPP - 1/2 NPT	1	1	1			1	1	1		
19	804809	Adapter 1/2BSPP - 1/2ORFS	1	1	1			1	1	1		
20	M0000096-16	Hose Assy..	1	1	1			1	1	1		
21	58530	Bolt, M8-1.25x45 PC8.8 Hex	4	4	4			4	4	4		
22	54242	Nut, M8-1.25 Hex Lock	4	4	4			4	4	4		
23	42818	Bolt, M16x40 PC8.8 Hex	2	2	2			2	2	2		
24	42322	Washer, M16 Lock	2	2	2			2	2	2		
25	804881	Belt, 1/2 V-Groove	1	1	1			1	1	1		
26	804599	Hose Assy.	1	1	1			1	1	1		
27	804819	O-Ring For 804808	1	1	1			1	1	1		
28	813009	Elbow	2	2	2			2	2	2		
29	813025	Hose	1	1	1			1	1	1		

78.00

11 CD 161
TIER III

SENSORS, ENGINE AND TRANSMISSION (4-SPEED, 2WD/4WD)
SEE ALSO: **11 CC 228**

M30-2T	M30-4T	M30-2T H	M30-4T H
M40-2T	M40-4T	M40-2T H	M40-4T H
M50-2T	M50-4T	M50-2T H	M50-4T H

M30-2T L	M30-4T L	M30-2T H L	M30-4T H L
M40-2T L	M40-4T L	M40-2T H L	M40-4T H L
M50-2T L	M50-4T L	M50-2T H L	M50-4T H L

NOTE: ENGINE COMPONENTS SHOWN ARE FOR PERKINS ENGINES ONLY.
FOR CAT ENGINE COMPONENTS CONTACT YOUR NEAREST CATERPILLAR DEALER. FOR PERKINS
COMPONENTS NOT FOUND IN THIS PARTS MANUAL CONTACT YOUR NEAREST PERKINS DEALER.

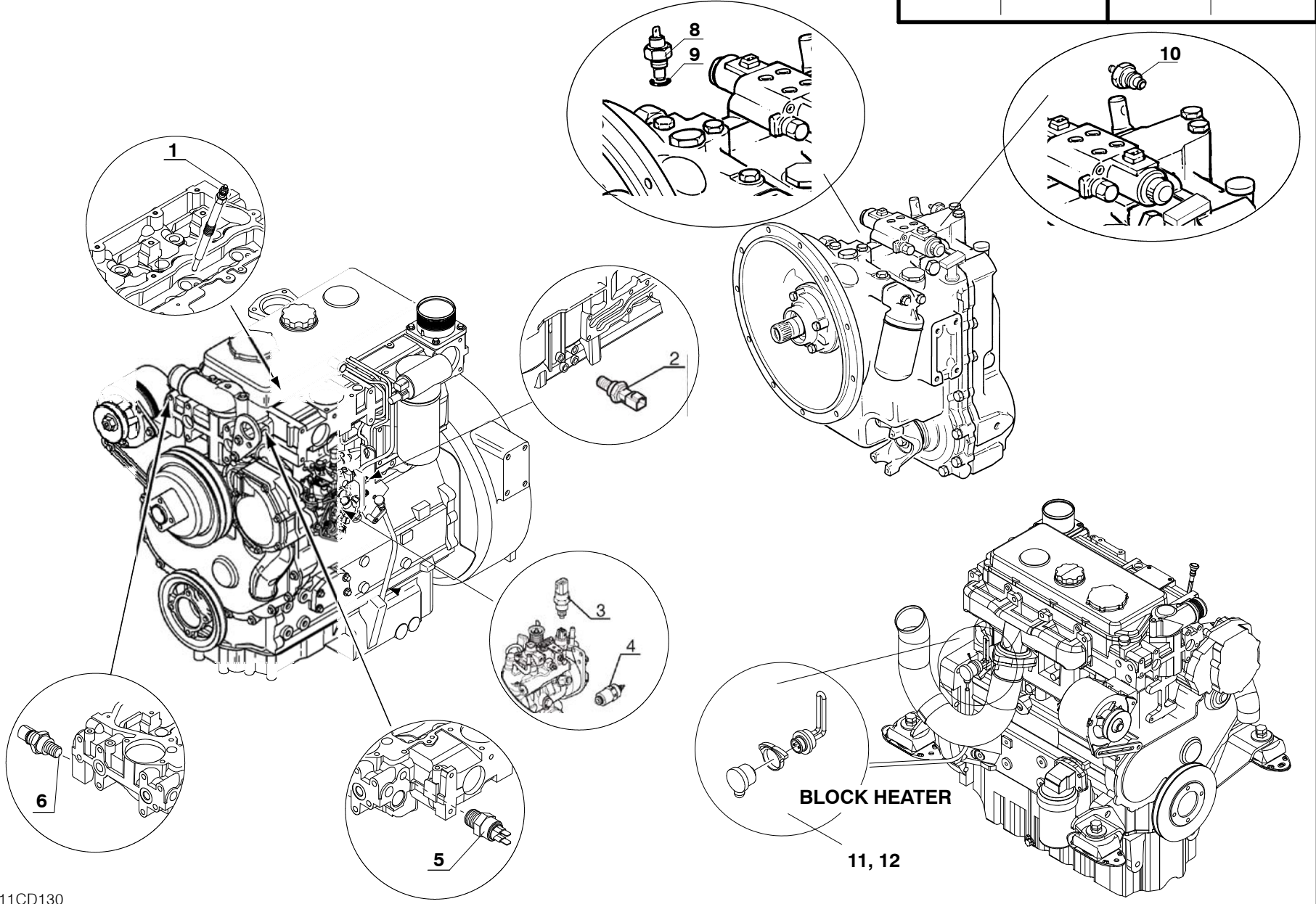

1	SENSORS, ENGINE AND TRANSMISSION (4-SPEED, 2WD/4WD)		QUANTITY / MODEL												11 CD 161			
			M30-4T	M40-4T	M50-4T		M30-4T H	M40-4T H	M50-4T H		M30-4T L	M40-4T L	M50-4T L		M30-4T HL	M40-4T HL	M50-4T HL	
			M30-2T	M40-2T	M50-2T		M30-2T H	M40-2T H	M50-2T H		M30-2T L	M40-2T L	M50-2T L		M30-2T HL	M40-2T HL	M50-2T HL	
ITEM	PART NO.	DESCRIPTION	M30-2T	M40-2T	M50-2T		M30-2T H	M40-2T H	M50-2T H		M30-2T L	M40-2T L	M50-2T L		M30-2T HL	M40-2T HL	M50-2T HL	
1	605030	Heating plug	4	4	4	4	4	4	4	4	4	4	4	4	4	4	4	4
2	745801	Engine oil pressure switch	1	1	1	1	1	1	1	1	1	1	1	1	1	1	1	1
3	601673	Electrovalve	1	1	1	1	1	1	1	1	1	1	1	1	1	1	1	1
4	705991	Electrovalve	1	1	1	1	1	1	1	1	1	1	1	1	1	1	1	1
5	604928	Water temp sensor	1	1	1	1	1	1	1	1	1	1	1	1	1	1	1	1
6	702318	Water temp sensor	1	1	1	1	1	1	1	1	1	1	1	1	1	1	1	1
8	552502	Oil temp sensor	1	1	1	1					1	1	1	1				
9	109657	O-ring	1	1	1	1					1	1	1	1				
10	549100	Transmission oil pressure switch	1	1	1	1					1	1	1	1				
11	496213	Engine block heater	1	1	1	1	1	1	1	1	1	1	1	1	1	1	1	1
12	802225	Tie wrap, 12 in.	2	2	2	2	2	2	2	2	2	2	2	2	2	2	2	2

12 AA 463

TIER III

803121)N

DECALS (SHEET 1 OF 2)

M30-2T	M30-4T	M30-2T H	M30-4T H
M40-2T	M40-4T	M40-2T H	M40-4T H
M50-2T	M50-4T	M50-2T H	M50-4T H
M30-2T L	M30-4T L	M30-2T H L	M30-4T H L
M40-2T L	M40-4T L	M40-2T H L	M40-4T H L
M50-2T L	M50-4T L	M50-2T H L	M50-4T H L

80.00

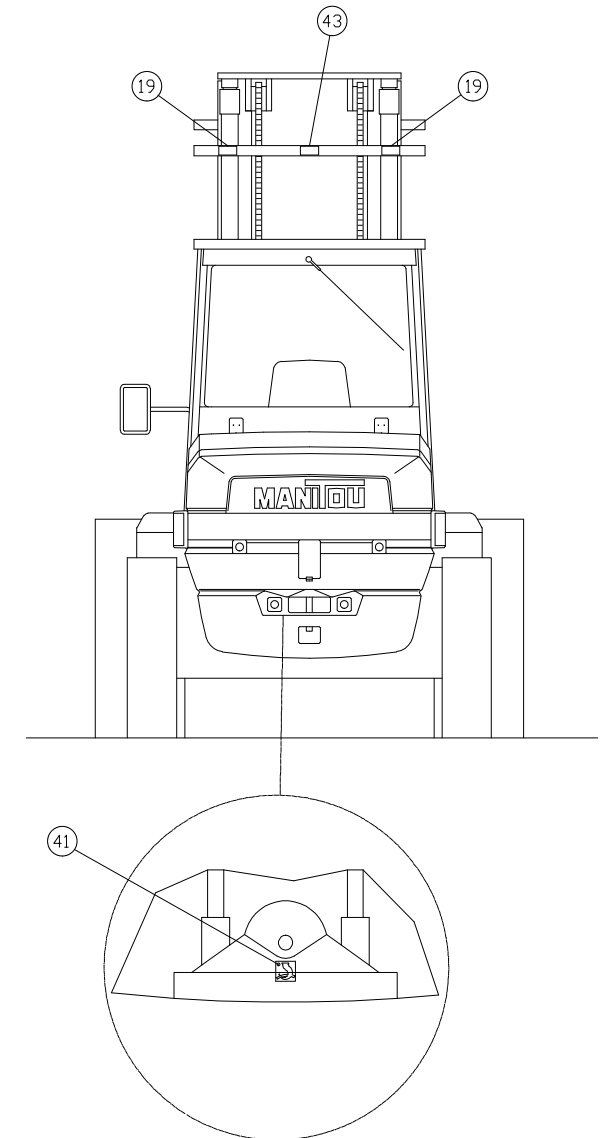
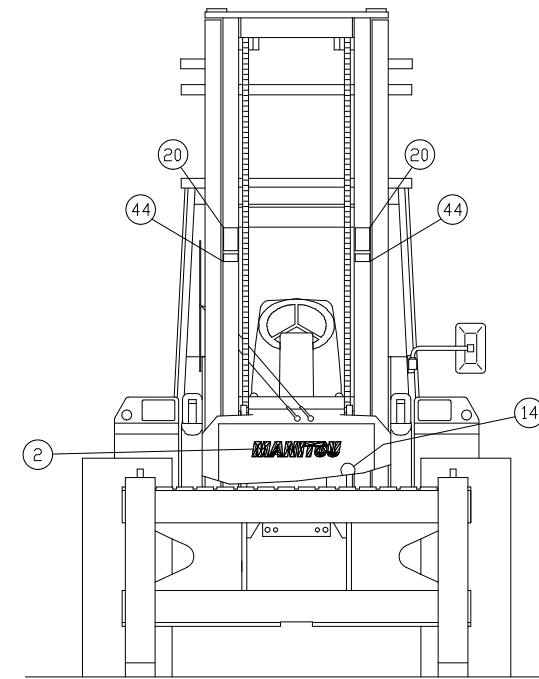
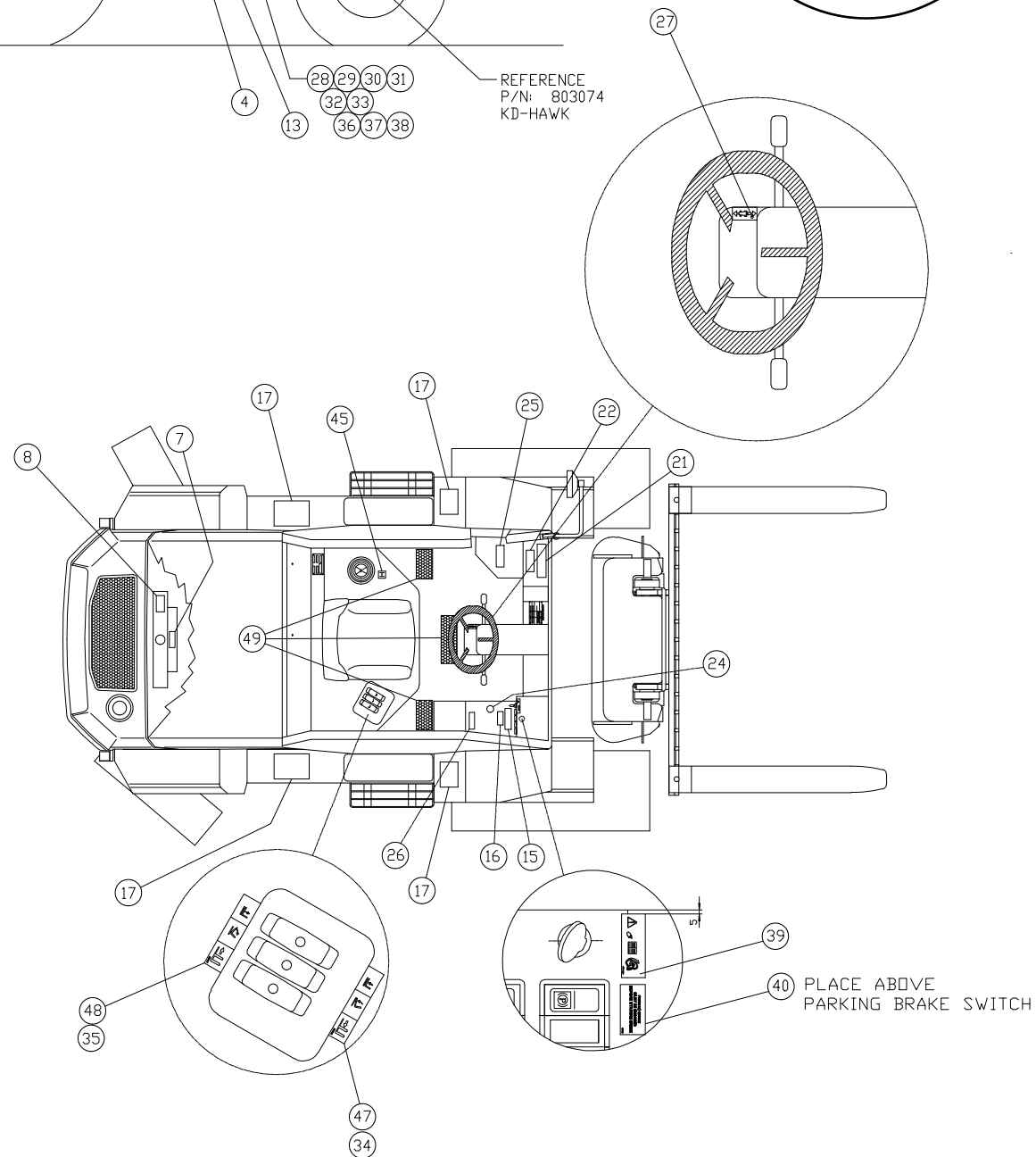
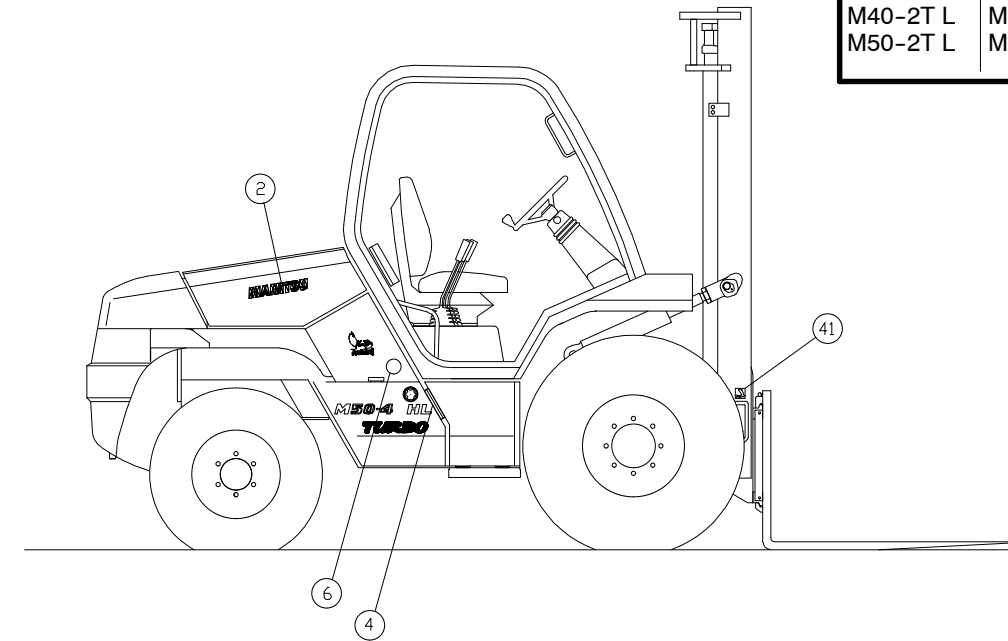
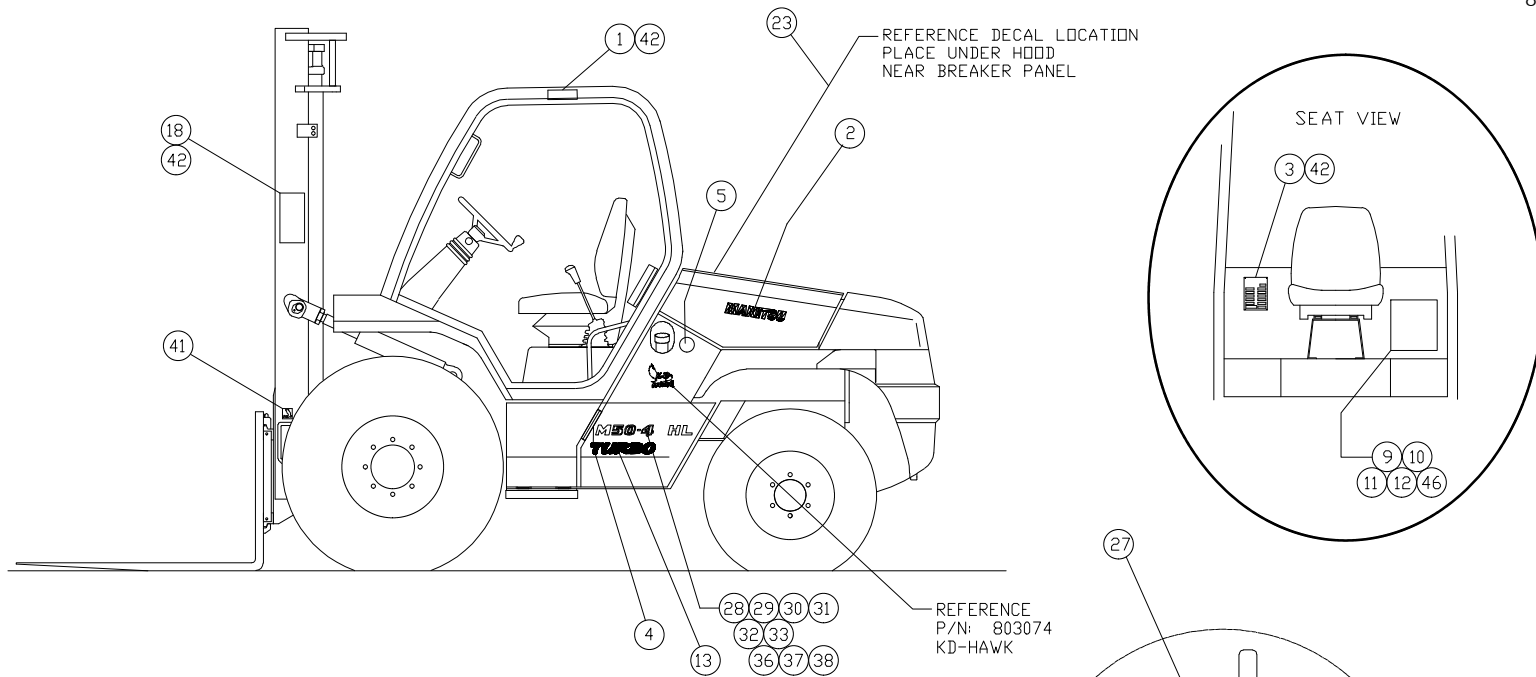

AP 1844
TIER III

ENGINE, COMPLETE

M30-2T	M30-4T	M30-2T H	M30-4T H
M40-2T	M40-4T	M40-2T H	M40-4T H
M50-2T	M50-4T	M50-2T H	M50-4T H
M30-2T L	M30-4T L	M30-2T H L	M30-4T H L
M40-2T L	M40-4T L	M40-2T H L	M40-4T H L
M50-2T L	M50-4T L	M50-2T H L	M50-4T H L

NOTE: ENGINE COMPONENTS SHOWN ARE FOR PERKINS ENGINES - EXCEPT AS NOTED*.
FOR COMPLETE CAT ENGINE SEE THE FOLLOWING PAGE, FOR ALL OTHER ENGINE COMPONENTS
CONTACT YOUR NEAREST CATERPILLAR DEALER
FOR PERKINS COMPONENTS NOT FOUND IN THIS PARTS MANUAL CONTACT YOUR NEAREST PERKINS
DEALER.

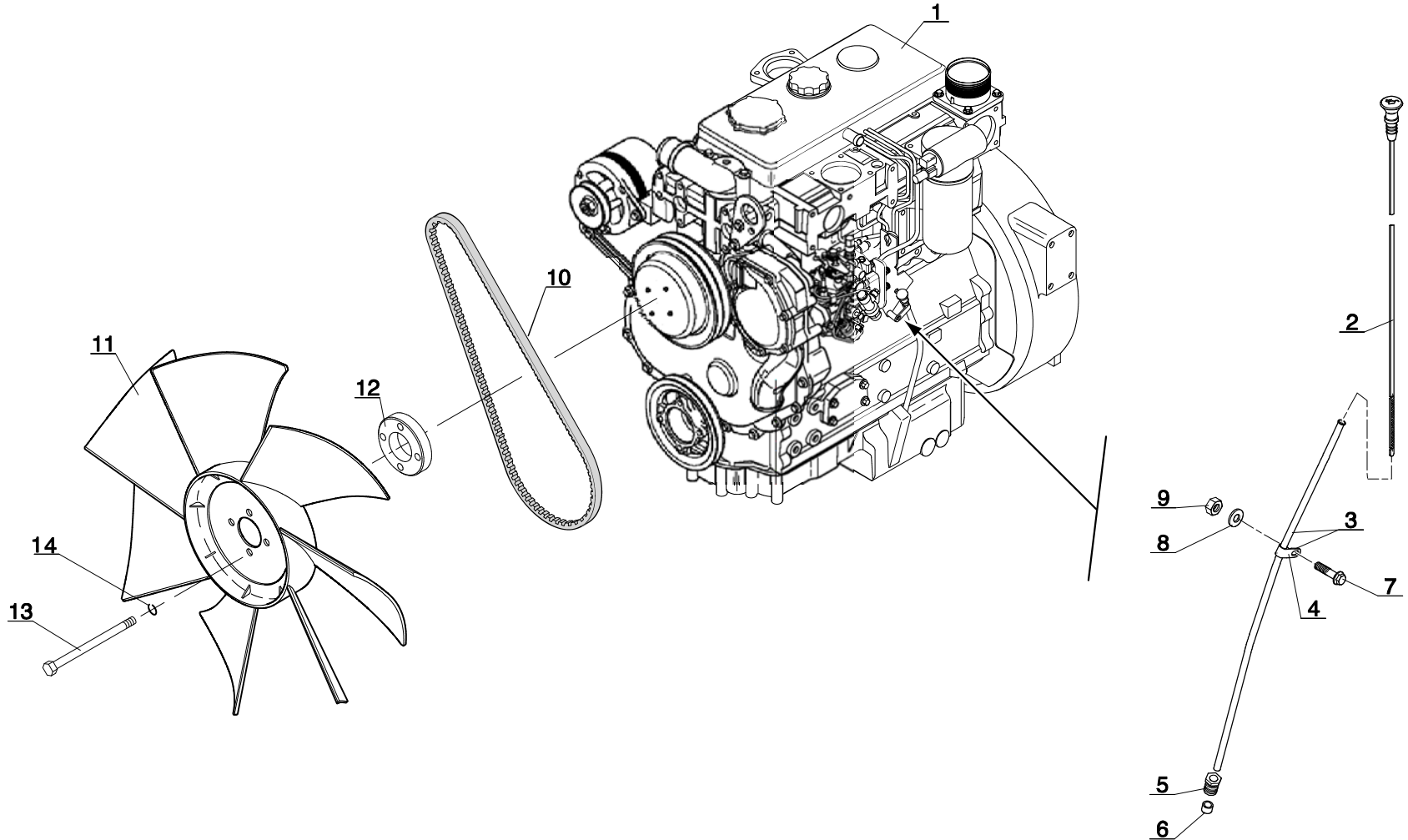

1	ENGINE, COMPLETE		QUANTITY / MODEL											AP 1844				
			M30-4T	M40-4T	M50-4T		M30-4T H	M40-4T H	M50-4T H		M30-4T L	M40-4T L	M50-4T L		M30-4T HL	M40-4T HL	M50-4T HL	
ITEM	PART NO.	DESCRIPTION	M30-2T	M40-2T	M50-2T		M30-2T H	M40-2T H	M50-2T H		M30-2T L	M40-2T L	M50-2T L		M30-2T HL	M40-2T HL	M50-2T HL	
1	265765	Complete Engine, Perkins 1104D-44T	1	1	1	1	1	1	1	1	1	1	1	1	1	1	1	1
1	807238	Complete Engine, Caterpillar 318-7159	1	1	1	1	1	1	1	1	1	1	1	1	1	1	1	1
2	702287	Dipstick	1	1	1	1	1	1	1	1	1	1	1	1	1	1	1	1
3	702286	Tube	1	1	1	1	1	1	1	1	1	1	1	1	1	1	1	1
4	702289	Clamp	1	1	1	1	1	1	1	1	1	1	1	1	1	1	1	1
5	474059	Nut	1	1	1	1	1	1	1	1	1	1	1	1	1	1	1	1
6	474060	O-ring	1	1	1	1	1	1	1	1	1	1	1	1	1	1	1	1
7	25713	Screw	1	1	1	1	1	1	1	1	1	1	1	1	1	1	1	1
8	189857	Washer	1	1	1	1	1	1	1	1	1	1	1	1	1	1	1	1
9	162229	Nut	1	1	1	1	1	1	1	1	1	1	1	1	1	1	1	1
10*	702494	Belt	1	1	1	1	1	1	1	1	1	1	1	1	1	1	1	1
11*	807867	Fan	1	1	1	1	1	1	1	1	1	1	1	1	1	1	1	1
12	807850	Spacer, fan	1	1	1	1	1	1	1	1	1	1	1	1	1	1	1	1
13	61323	Bolt	4	4	4	4	4	4	4	4	4	4	4	4	4	4	4	4
14	61674	Washer	4	4	4	4	4	4	4	4	4	4	4	4	4	4	4	4
* Used on Perkins and Cat engines.																		

AP 1950
TIER III

ENGINE, CYLINDER BLOCK

M30-2T	M30-4T	M30-2T H	M30-4T H
M40-2T	M40-4T	M40-2T H	M40-4T H
M50-2T	M50-4T	M50-2T H	M50-4T H

NOTE: ENGINE COMPONENTS SHOWN ARE FOR PERKINS ENGINES.
FOR CAT ENGINE COMPONENTS CONTACT YOUR NEAREST CATERPILLAR DEALER.
FOR PERKINS COMPONENTS NOT FOUND IN THIS PARTS MANUAL CONTACT YOUR NEAREST PERKINS DEALER.

M30-2T L	M30-4T L	M30-2T H L	M30-4T H L
M40-2T L	M40-4T L	M40-2T H L	M40-4T H L
M50-2T L	M50-4T L	M50-2T H L	M50-4T H L

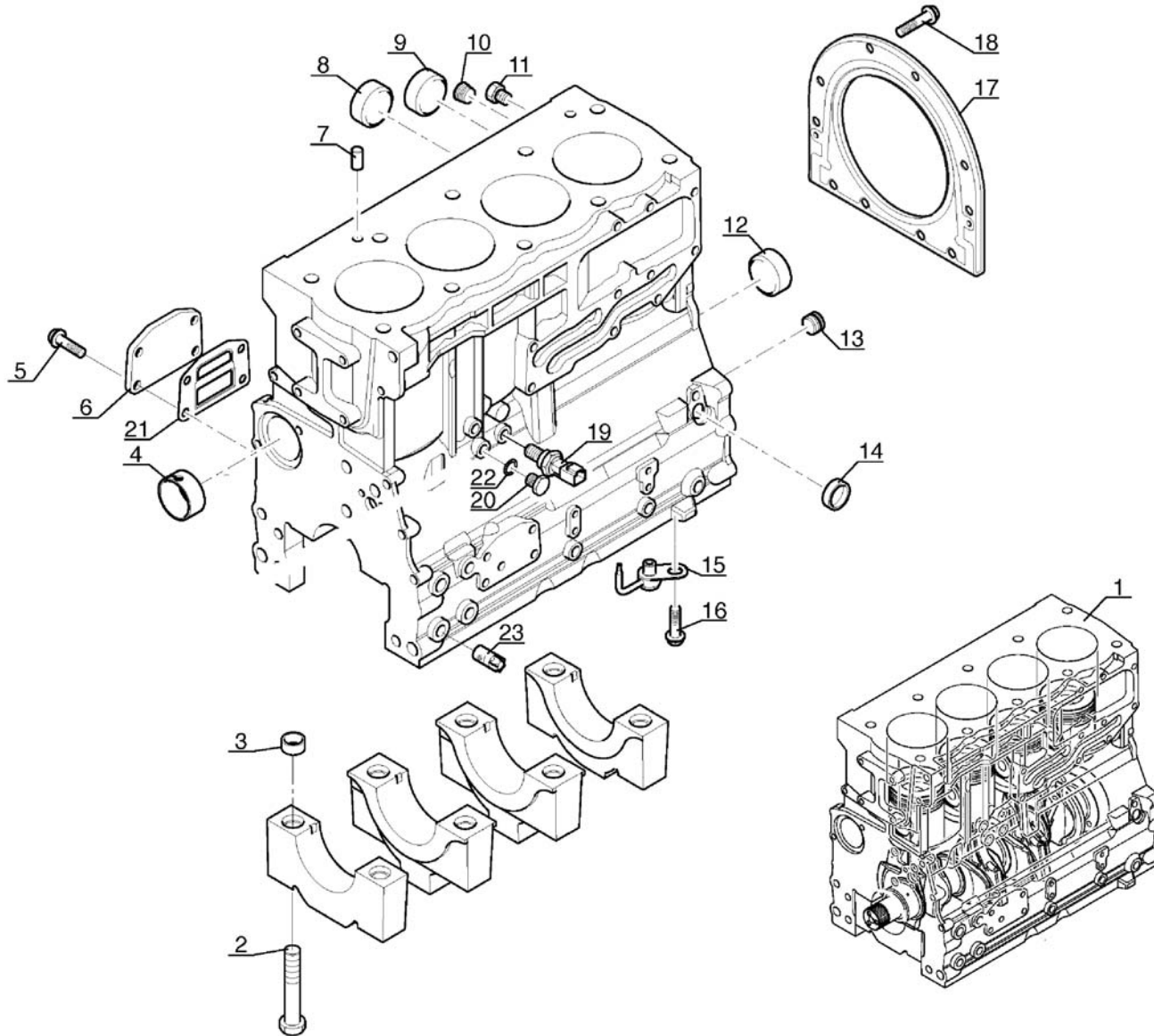

1	ENGINE, CYLINDER BLOCK		QUANTITY / MODEL												AP 1950		
			M30-4T	M40-4T	M50-4T		M30-4T H	M40-4T H	M50-4T H		M30-4T L	M40-4T L	M50-4T L		M30-4T HL	M40-4T HL	M50-4T HL
ITEM	PART NO.	DESCRIPTION	M30-2T	M40-2T	M50-2T		M30-2T H	M40-2T H	M50-2T H		M30-2T L	M40-2T L	M50-2T L		M30-2T HL	M40-2T HL	M50-2T HL
1	748404	Short block	1	1	1	1	1	1	1	1	1	1	1	1	1	1	1
2	138222	Screw	10	10	10	10	10	10	10	10	10	10	10	10	10	10	10
3	133831	Spacer	10	10	10	10	10	10	10	10	10	10	10	10	10	10	10
4	604879	Bushing	1	1	1	1	1	1	1	1	1	1	1	1	1	1	1
5	473955	Screw	4	4	4	4	4	4	4	4	4	4	4	4	4	4	4
6	702052	Fastening plate	1	1	1	1	1	1	1	1	1	1	1	1	1	1	1
7	563532	Centering pin	2	2	2	2	2	2	2	2	2	2	2	2	2	2	2
8	604881	Plug	2	2	2	2	2	2	2	2	2	2	2	2	2	2	2
9	139365	Plug	1	1	1	1	1	1	1	1	1	1	1	1	1	1	1
10	133655	Plug	1	1	1	1	1	1	1	1	1	1	1	1	1	1	1
11	604883	Plug	1	1	1	1	1	1	1	1	1	1	1	1	1	1	1
12	604880	Plug	1	1	1	1	1	1	1	1	1	1	1	1	1	1	1
13	604882	Plug	1	1	1	1	1	1	1	1	1	1	1	1	1	1	1
14	604889	Plug	1	1	1	1	1	1	1	1	1	1	1	1	1	1	1
15	706964	Fuel jet	4	4	4	4	4	4	4	4	4	4	4	4	4	4	4
16	474138	Screw	4	4	4	4	4	4	4	4	4	4	4	4	4	4	4
17	604887	Housing	1	1	1	1	1	1	1	1	1	1	1	1	1	1	1
18	604888	Screw	10	10	10	10	10	10	10	10	10	10	10	10	10	10	10
19	745801	Oil press switch	1	1	1	1	1	1	1	1	1	1	1	1	1	1	1
20	474041	Screw	1	1	1	1	1	1	1	1	1	1	1	1	1	1	1
21	604973	Gasket	1	1	1	1	1	1	1	1	1	1	1	1	1	1	1
22	603433	Washer	1	1	1	1	1	1	1	1	1	1	1	1	1	1	1
23	702657	Plug	4	4	4	4	4	4	4	4	4	4	4	4	4	4	4

AP 1951

TIER III

ENGINE, CRANKSHAFT

M30-2T	M30-4T	M30-2T H	M30-4T H
M40-2T	M40-4T	M40-2T H	M40-4T H
M50-2T	M50-4T	M50-2T H	M50-4T H

NOTE: ENGINE COMPONENTS SHOWN ARE FOR PERKINS ENGINES.
 FOR CAT ENGINE COMPONENTS CONTACT YOUR NEAREST CATERPILLAR DEALER.
 FOR PERKINS COMPONENTS NOT FOUND IN THIS PARTS MANUAL CONTACT YOUR NEAREST PERKINS DEALER.

M30-2T L	M30-4T L	M30-2T H L	M30-4T H L
M40-2T L	M40-4T L	M40-2T H L	M40-4T H L
M50-2T L	M50-4T L	M50-2T H L	M50-4T H L

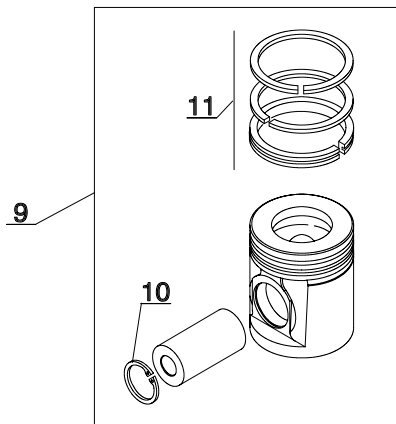

- (F)12
- (G)13
- (H)14
- (J)15
- (K)16
- (L)17

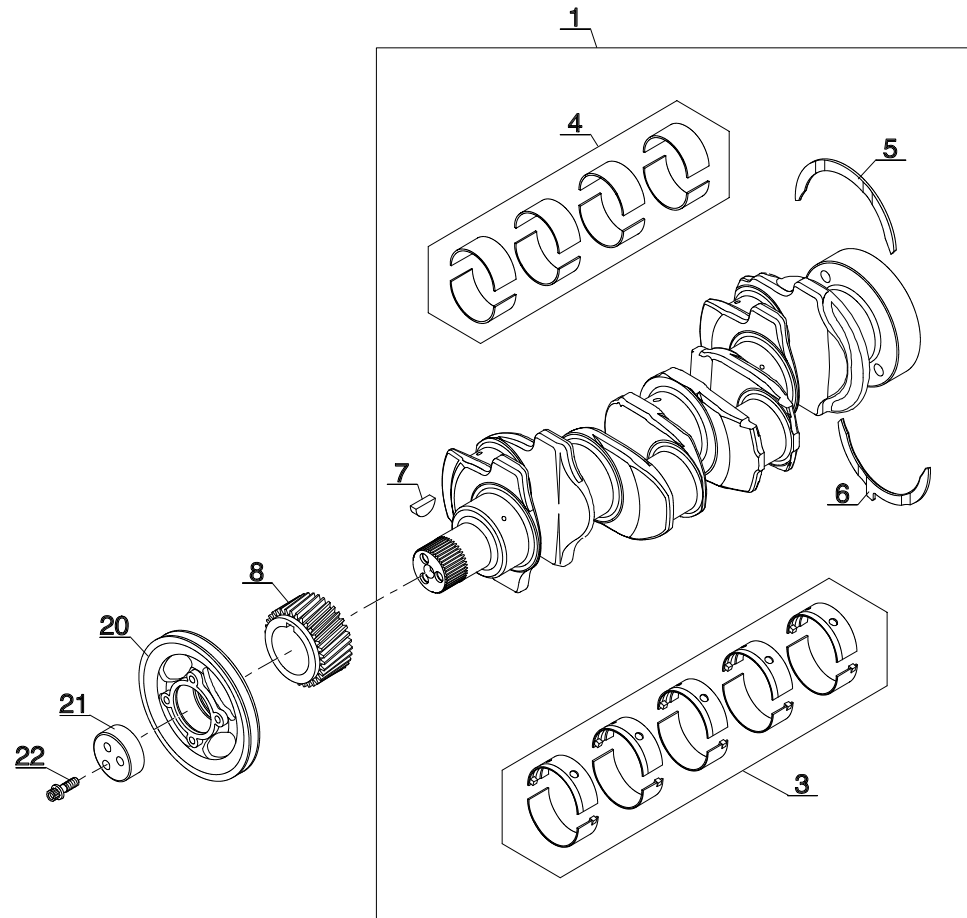
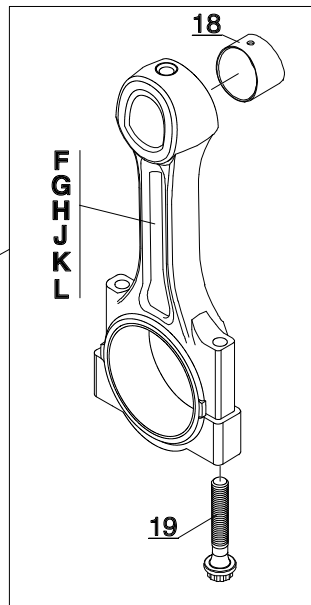

1	ENGINE, CRANKSHAFT		QUANTITY / MODEL												AP 1951		
			M30-4T	M40-4T	M50-4T		M30-4T H	M40-4T H	M50-4T H		M30-4T L	M40-4T L	M50-4T L		M30-4T HL	M40-4T HL	M50-4T HL
			M30-2T	M40-2T	M50-2T		M30-2T H	M40-2T H	M50-2T H		M30-2T L	M40-2T L	M50-2T L		M30-2T HL	M40-2T HL	M50-2T HL
ITEM	PART NO.	DESCRIPTION	M30-2T	M40-2T	M50-2T		M30-2T H	M40-2T H	M50-2T H		M30-2T L	M40-2T L	M50-2T L		M30-2T HL	M40-2T HL	M50-2T HL
1	702000	Crankshaft	1	1	1	1	1	1	1	1	1	1	1	1	1	1	1
3	604894	Main bearing set (standard)	1	1	1	1	1	1	1	1	1	1	1	1	1	1	1
3	604895	Main bearing set (+.010 in.)	A/R	A/R	A/R	A/R	A/R	A/R	A/R	A/R	A/R	A/R	A/R	A/R	A/R	A/R	A/R
3	604896	Main bearing set (+.020 in.)	A/R	A/R	A/R	A/R	A/R	A/R	A/R	A/R	A/R	A/R	A/R	A/R	A/R	A/R	A/R
3	604897	Main bearing set (+.030 in.)	A/R	A/R	A/R	A/R	A/R	A/R	A/R	A/R	A/R	A/R	A/R	A/R	A/R	A/R	A/R
4	745798	Rod bearing set (standard)	1	1	1	1	1	1	1	1	1	1	1	1	1	1	1
4	746100	Rod bearing set (+.010 in.)	A/R	A/R	A/R	A/R	A/R	A/R	A/R	A/R	A/R	A/R	A/R	A/R	A/R	A/R	A/R
4	746101	Rod bearing set (+.020 in.)	A/R	A/R	A/R	A/R	A/R	A/R	A/R	A/R	A/R	A/R	A/R	A/R	A/R	A/R	A/R
4	746102	Rod bearing set (+.030 in.)	A/R	A/R	A/R	A/R	A/R	A/R	A/R	A/R	A/R	A/R	A/R	A/R	A/R	A/R	A/R
5	109834	Spacer (standard)	1	1	1	1	1	1	1	1	1	1	1	1	1	1	1
5	133768	Spacer (+.007 in.)	A/R	A/R	A/R	A/R	A/R	A/R	A/R	A/R	A/R	A/R	A/R	A/R	A/R	A/R	A/R
6	109835	Spacer (standard)	1	1	1	1	1	1	1	1	1	1	1	1	1	1	1
6	133770	Spacer (+.007 in.)	A/R	A/R	A/R	A/R	A/R	A/R	A/R	A/R	A/R	A/R	A/R	A/R	A/R	A/R	A/R
7	133636	Key	1	1	1	1	1	1	1	1	1	1	1	1	1	1	1
8	604912	Gear	1	1	1	1	1	1	1	1	1	1	1	1	1	1	1
9	747605	Piston	4	4	4	4	4	4	4	4	4	4	4	4	4	4	4
10	563226	Circlip	2	2	2	2	2	2	2	2	2	2	2	2	2	2	2
11	740840	Piston ring kit	1	1	1	1	1	1	1	1	1	1	1	1	1	1	1
12	604904	Connecting rod (F)	4	4	4	4	4	4	4	4	4	4	4	4	4	4	4
13	604905	Connecting rod (G)	4	4	4	4	4	4	4	4	4	4	4	4	4	4	4
14	604906	Connecting rod (H)	4	4	4	4	4	4	4	4	4	4	4	4	4	4	4
15	604907	Connecting rod (J)	4	4	4	4	4	4	4	4	4	4	4	4	4	4	4
16	604908	Connecting rod (K)	4	4	4	4	4	4	4	4	4	4	4	4	4	4	4
17	604909	Connecting rod (L)	4	4	4	4	4	4	4	4	4	4	4	4	4	4	4
18	604910	Bushing	1	1	1	1	1	1	1	1	1	1	1	1	1	1	1
19	604911	Screw	2	2	2	2	2	2	2	2	2	2	2	2	2	2	2
20	702618	Pulley	1	1	1	1	1	1	1	1	1	1	1	1	1	1	1
21	474037	Spacer	1	1	1	1	1	1	1	1	1	1	1	1	1	1	1
22	474038	Screw	3	3	3	3	3	3	3	3	3	3	3	3	3	3	3

AP 1952
TIER III

ENGINE, CYLINDER HEAD

M30-2T	M30-4T	M30-2T H	M30-4T H
M40-2T	M40-4T	M40-2T H	M40-4T H
M50-2T	M50-4T	M50-2T H	M50-4T H
M30-2T L	M30-4T L	M30-2T H L	M30-4T H L
M40-2T L	M40-4T L	M40-2T H L	M40-4T H L
M50-2T L	M50-4T L	M50-2T H L	M50-4T H L

NOTE: ENGINE COMPONENTS SHOWN ARE FOR PERKINS ENGINES.
FOR CAT ENGINE COMPONENTS CONTACT YOUR NEAREST CATERPILLAR DEALER.
FOR PERKINS COMPONENTS NOT FOUND IN THIS PARTS MANUAL CONTACT YOUR NEAREST PERKINS DEALER.

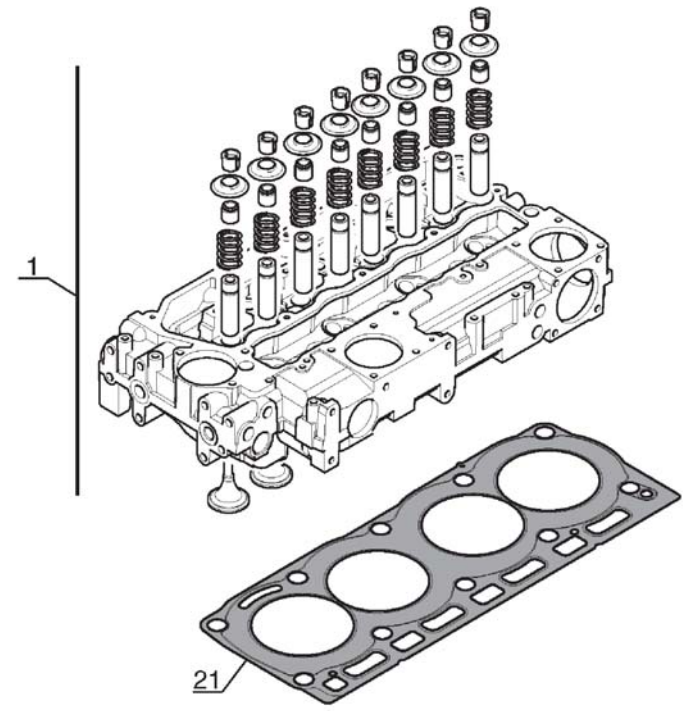
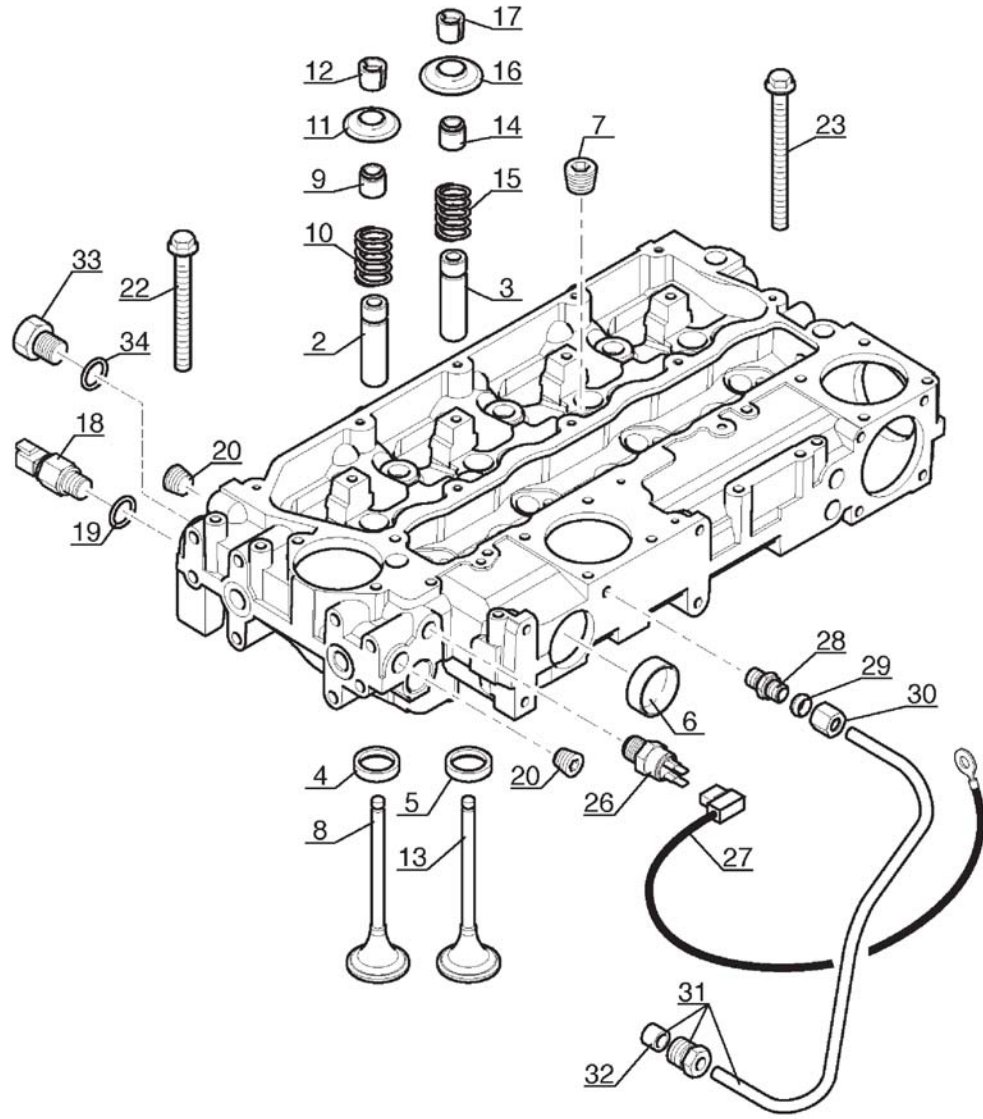

1	ENGINE, CYLINDER HEAD		QUANTITY / MODEL											AP 1952			
			M30-4T	M40-4T	M50-4T		M30-4T H	M40-4T H	M50-4T H		M30-4T L	M40-4T L	M50-4T L		M30-4T HL	M40-4T HL	M50-4T HL
ITEM	PART NO.	DESCRIPTION	M30-2T	M40-2T	M50-2T		M30-2T H	M40-2T H	M50-2T H		M30-2T L	M40-2T L	M50-2T L		M30-2T HL	M40-2T HL	M50-2T HL
1	747606	Cylinder head, complete	1	1	1	1	1	1	1	1	1	1	1	1	1	1	1
2	563233	Guide	4	4	4	4	4	4	4	4	4	4	4	4	4	4	4
3	563233	Guide	4	4	4	4	4	4	4	4	4	4	4	4	4	4	4
4	747607	Bushing, intake	4	4	4	4	4	4	4	4	4	4	4	4	4	4	4
5	747608	Bushing, exhaust	4	4	4	4	4	4	4	4	4	4	4	4	4	4	4
6	474101	Plug	2	2	2	2	2	2	2	2	2	2	2	2	2	2	2
7	133655	Plug	4	4	4	4	4	4	4	4	4	4	4	4	4	4	4
8	747609	Intake valve	4	4	4	4	4	4	4	4	4	4	4	4	4	4	4
9	704713	Seal	4	4	4	4	4	4	4	4	4	4	4	4	4	4	4
10	747610	Spring	4	4	4	4	4	4	4	4	4	4	4	4	4	4	4
11	747611	Cap	4	4	4	4	4	4	4	4	4	4	4	4	4	4	4
12	747612	Cotter	8	8	8	8	8	8	8	8	8	8	8	8	8	8	8
13	747613	Exhaust valve	4	4	4	4	4	4	4	4	4	4	4	4	4	4	4
14	706965	Seal	4	4	4	4	4	4	4	4	4	4	4	4	4	4	4
15	747610	Spring	4	4	4	4	4	4	4	4	4	4	4	4	4	4	4
16	747611	Cap	4	4	4	4	4	4	4	4	4	4	4	4	4	4	4
17	747612	Cotter	8	8	8	8	8	8	8	8	8	8	8	8	8	8	8
18	702318	Water temp sensor	1	1	1	1	1	1	1	1	1	1	1	1	1	1	1
19	604922	O-ring	1	1	1	1	1	1	1	1	1	1	1	1	1	1	1
20	133739	Plug	2	2	2	2	2	2	2	2	2	2	2	2	2	2	2
21	704934	Cylinder head gasket	1	1	1	1	1	1	1	1	1	1	1	1	1	1	1
22	604924	Screw	7	7	7	7	7	7	7	7	7	7	7	7	7	7	7
23	604925	Screw	3	3	3	3	3	3	3	3	3	3	3	3	3	3	3
26	604928	Water temp sensor	1	1	1	1	1	1	1	1	1	1	1	1	1	1	1
27	702126	Wiring harness	1	1	1	1	1	1	1	1	1	1	1	1	1	1	1
28	108127	Connection	1	1	1	1	1	1	1	1	1	1	1	1	1	1	1

AP 1953
TIER III

ENGINE, ROCKER ARMS

M30-2T	M30-4T	M30-2T H	M30-4T H
M40-2T	M40-4T	M40-2T H	M40-4T H
M50-2T	M50-4T	M50-2T H	M50-4T H
M30-2T L	M30-4T L	M30-2T H L	M30-4T H L
M40-2T L	M40-4T L	M40-2T H L	M40-4T H L
M50-2T L	M50-4T L	M50-2T H L	M50-4T H L

NOTE: ENGINE COMPONENTS SHOWN ARE FOR PERKINS ENGINES.
FOR CAT ENGINE COMPONENTS CONTACT YOUR NEAREST CATERPILLAR DEALER.
FOR PERKINS COMPONENTS NOT FOUND IN THIS PARTS MANUAL CONTACT YOUR NEAREST PERKINS DEALER.

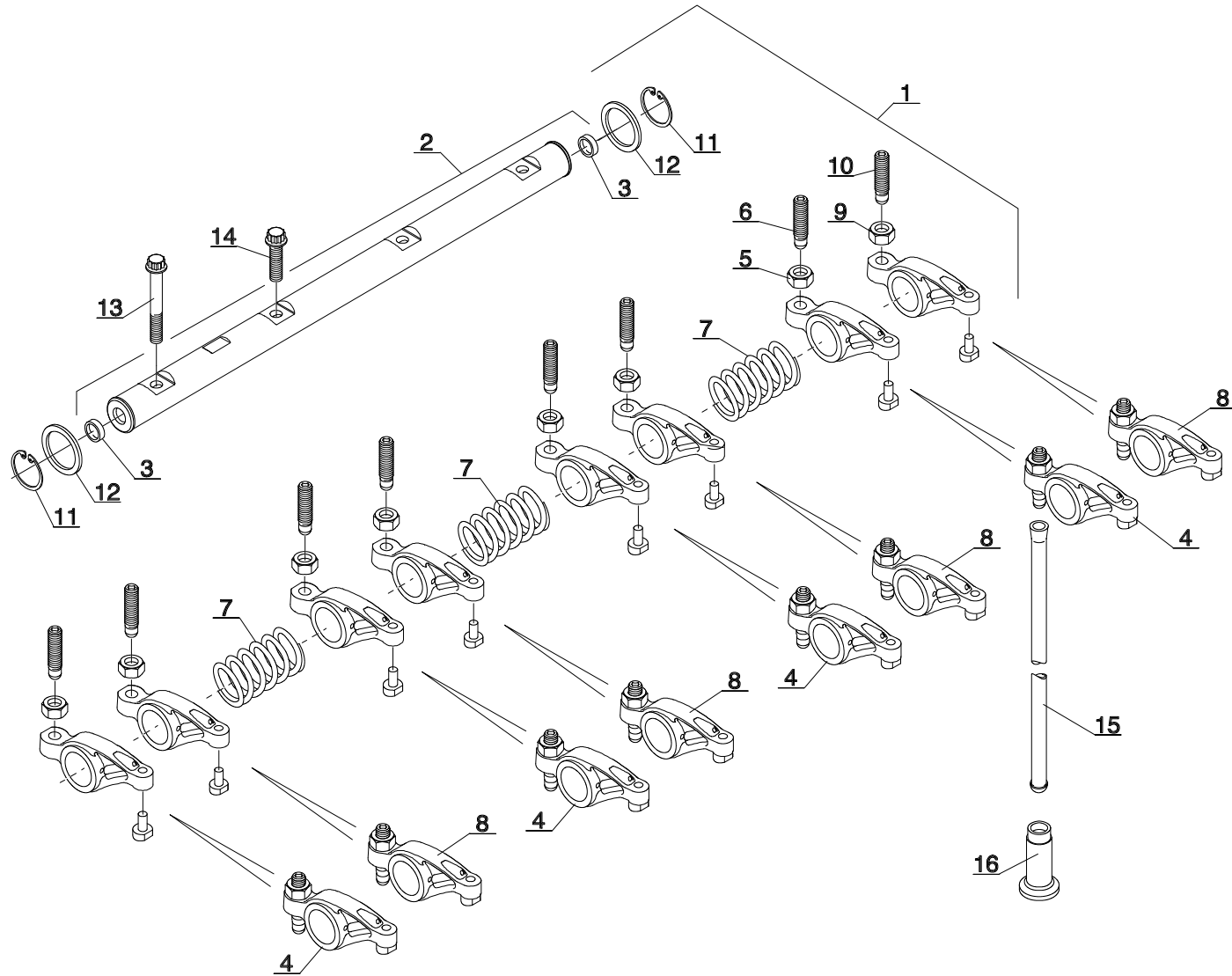

1	ENGINE, ROCKER ARMS		QUANTITY / MODEL											AP 1953			
			M30-4T	M40-4T	M50-4T		M30-4T H	M40-4T H	M50-4T H		M30-4T L	M40-4T L	M50-4T L		M30-4T HL	M40-4T HL	M50-4T HL
ITEM	PART NO.	DESCRIPTION	M30-2T	M40-2T	M50-2T		M30-2T H	M40-2T H	M50-2T H		M30-2T L	M40-2T L	M50-2T L		M30-2T HL	M40-2T HL	M50-2T HL
1	747614	Rocker assembly, complete	1	1	1	1	1	1	1	1	1	1	1	1	1	1	1
2	604931	Shaft	1	1	1	1	1	1	1	1	1	1	1	1	1	1	1
3	604932	Plug	2	2	2	2	2	2	2	2	2	2	2	2	2	2	2
4	747615	Rocker, exhaust	4	4	4	4	4	4	4	4	4	4	4	4	4	4	4
5	747616	Nut	1	1	1	1	1	1	1	1	1	1	1	1	1	1	1
6	740862	Screw	1	1	1	1	1	1	1	1	1	1	1	1	1	1	1
7	604934	Spring	3	3	3	3	3	3	3	3	3	3	3	3	3	3	3
8	747617	Rocker lever, intake	4	4	4	4	4	4	4	4	4	4	4	4	4	4	4
9	747616	Nut	1	1	1	1	1	1	1	1	1	1	1	1	1	1	1
10	740862	Screw	1	1	1	1	1	1	1	1	1	1	1	1	1	1	1
11	604936	Circlip	2	2	2	2	2	2	2	2	2	2	2	2	2	2	2
12	604937	Washer	2	2	2	2	2	2	2	2	2	2	2	2	2	2	2
13	604938	Screw	1	1	1	1	1	1	1	1	1	1	1	1	1	1	1
14	604939	Screw	3	3	3	3	3	3	3	3	3	3	3	3	3	3	3
15	740873	Rod	8	8	8	8	8	8	8	8	8	8	8	8	8	8	8
16	747371	Valve tappet	8	8	8	8	8	8	8	8	8	8	8	8	8	8	8

AP 1954
TIER III

ENGINE, TIMING GEAR AND CAM

M30-2T	M30-4T	M30-2T H	M30-4T H
M40-2T	M40-4T	M40-2T H	M40-4T H
M50-2T	M50-4T	M50-2T H	M50-4T H
M30-2T L	M30-4T L	M30-2T H L	M30-4T H L
M40-2T L	M40-4T L	M40-2T H L	M40-4T H L
M50-2T L	M50-4T L	M50-2T H L	M50-4T H L

NOTE: ENGINE COMPONENTS SHOWN ARE FOR PERKINS ENGINES.
FOR CAT ENGINE COMPONENTS CONTACT YOUR NEAREST CATERPILLAR DEALER.
FOR PERKINS COMPONENTS NOT FOUND IN THIS PARTS MANUAL CONTACT YOUR NEAREST PERKINS DEALER.

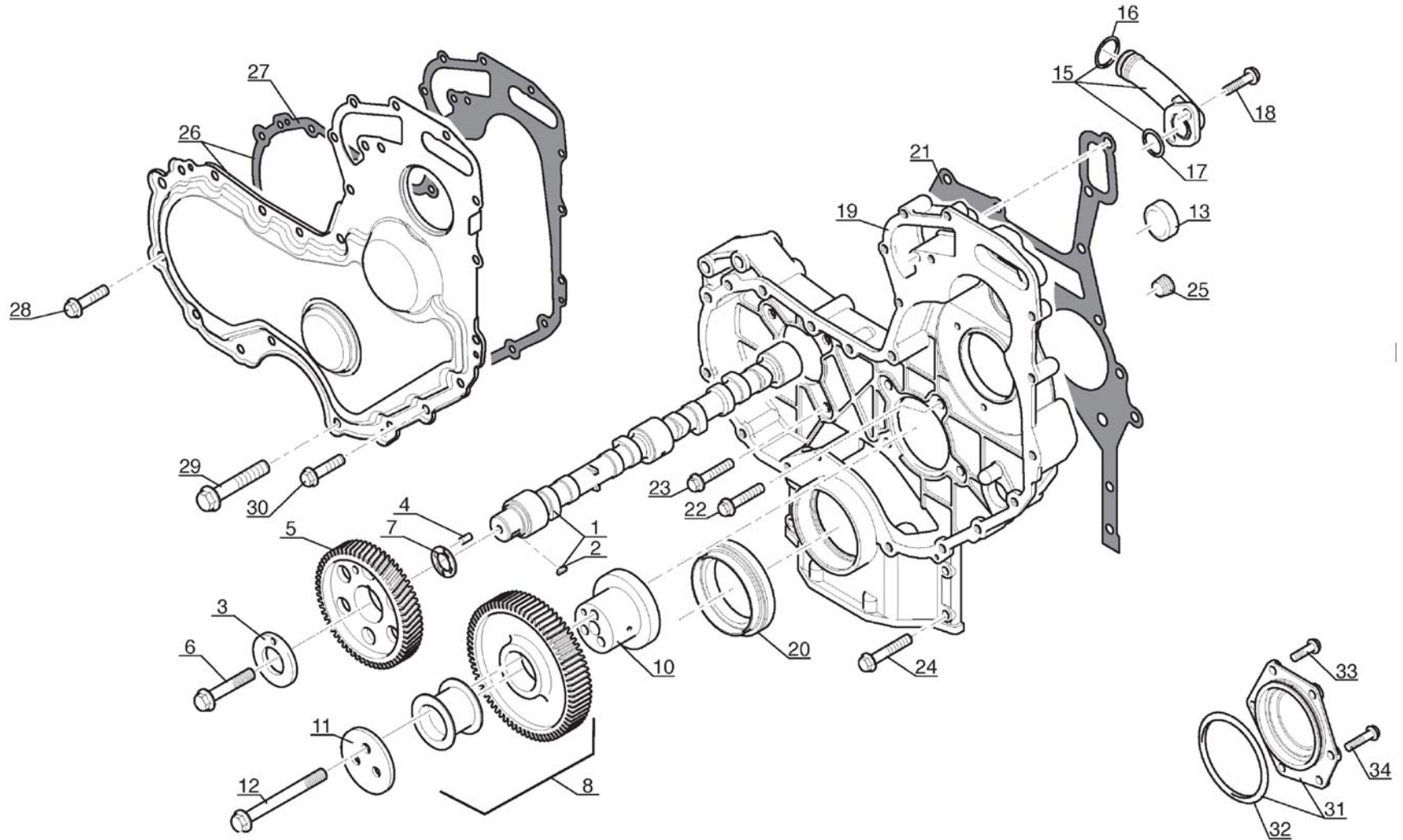

1	ENGINE, TIMING GEAR AND CAM		QUANTITY / MODEL												AP 1954			
			M30-4T	M40-4T	M50-4T		M30-4T H	M40-4T H	M50-4T H		M30-4T L	M40-4T L	M50-4T L		M30-4T HL	M40-4T HL	M50-4T HL	
			M30-2T	M40-2T	M50-2T		M30-2T H	M40-2T H	M50-2T H		M30-2T L	M40-2T L	M50-2T L		M30-2T HL	M40-2T HL	M50-2T HL	
ITEM	PART NO.	DESCRIPTION	M30-2T	M40-2T	M50-2T		M30-2T H	M40-2T H	M50-2T H		M30-2T L	M40-2T L	M50-2T L		M30-2T HL	M40-2T HL	M50-2T HL	
1	747648	Camshaft	1	1	1	1	1	1	1	1	1	1	1	1	1	1	1	1
2	133636	Key	1	1	1	1	1	1	1	1	1	1	1	1	1	1	1	1
3	474007	Washer	1	1	1	1	1	1	1	1	1	1	1	1	1	1	1	1
4	133714	Pin	1	1	1	1	1	1	1	1	1	1	1	1	1	1	1	1
5	604950	Gear	1	1	1	1	1	1	1	1	1	1	1	1	1	1	1	1
6	473297	Screw	1	1	1	1	1	1	1	1	1	1	1	1	1	1	1	1
7	702007	Washer	1	1	1	1	1	1	1	1	1	1	1	1	1	1	1	1
8	703172	Gear	1	1	1	1	1	1	1	1	1	1	1	1	1	1	1	1
10	747530	Hub	1	1	1	1	1	1	1	1	1	1	1	1	1	1	1	1
11	745669	Plate	1	1	1	1	1	1	1	1	1	1	1	1	1	1	1	1
12	473996	Screw	3	3	3	3	3	3	3	3	3	3	3	3	3	3	3	3
13	604941	Plug	1	1	1	1	1	1	1	1	1	1	1	1	1	1	1	1
15	604943	Connection	1	1	1	1	1	1	1	1	1	1	1	1	1	1	1	1
16	604944	O-ring	1	1	1	1	1	1	1	1	1	1	1	1	1	1	1	1
17	604945	O-ring	1	1	1	1	1	1	1	1	1	1	1	1	1	1	1	1
18	107363	Screw	2	2	2	2	2	2	2	2	2	2	2	2	2	2	2	2
19	775827	Housing	1	1	1	1	1	1	1	1	1	1	1	1	1	1	1	1
20	706971	Seal	1	1	1	1	1	1	1	1	1	1	1	1	1	1	1	1
21	706972	Gasket	1	1	1	1	1	1	1	1	1	1	1	1	1	1	1	1
22	473951	Screw	1	1	1	1	1	1	1	1	1	1	1	1	1	1	1	1
23	107363	Screw	8	8	8	8	8	8	8	8	8	8	8	8	8	8	8	8
24	474005	Screw	4	4	4	4	4	4	4	4	4	4	4	4	4	4	4	4
25	133739	Plug	1	1	1	1	1	1	1	1	1	1	1	1	1	1	1	1
26	702310	Housing/gasket	1	1	1	1	1	1	1	1	1	1	1	1	1	1	1	1
27	702311	Gasket	1	1	1	1	1	1	1	1	1	1	1	1	1	1	1	1
28	474064	Screw	9	9	9	9	9	9	9	9	9	9	9	9	9	9	9	9

86.00

AP 1955
TIER III

ENGINE, OIL PUMP AND PAN

M30-2T	M30-4T	M30-2T H	M30-4T H
M40-2T	M40-4T	M40-2T H	M40-4T H
M50-2T	M50-4T	M50-2T H	M50-4T H
M30-2T L	M30-4T L	M30-2T H L	M30-4T H L
M40-2T L	M40-4T L	M40-2T H L	M40-4T H L
M50-2T L	M50-4T L	M50-2T H L	M50-4T H L

NOTE: ENGINE COMPONENTS SHOWN ARE FOR PERKINS ENGINES.
FOR CAT ENGINE COMPONENTS CONTACT YOUR NEAREST CATERPILLAR DEALER.
FOR PERKINS COMPONENTS NOT FOUND IN THIS PARTS MANUAL CONTACT YOUR NEAREST PERKINS DEALER.

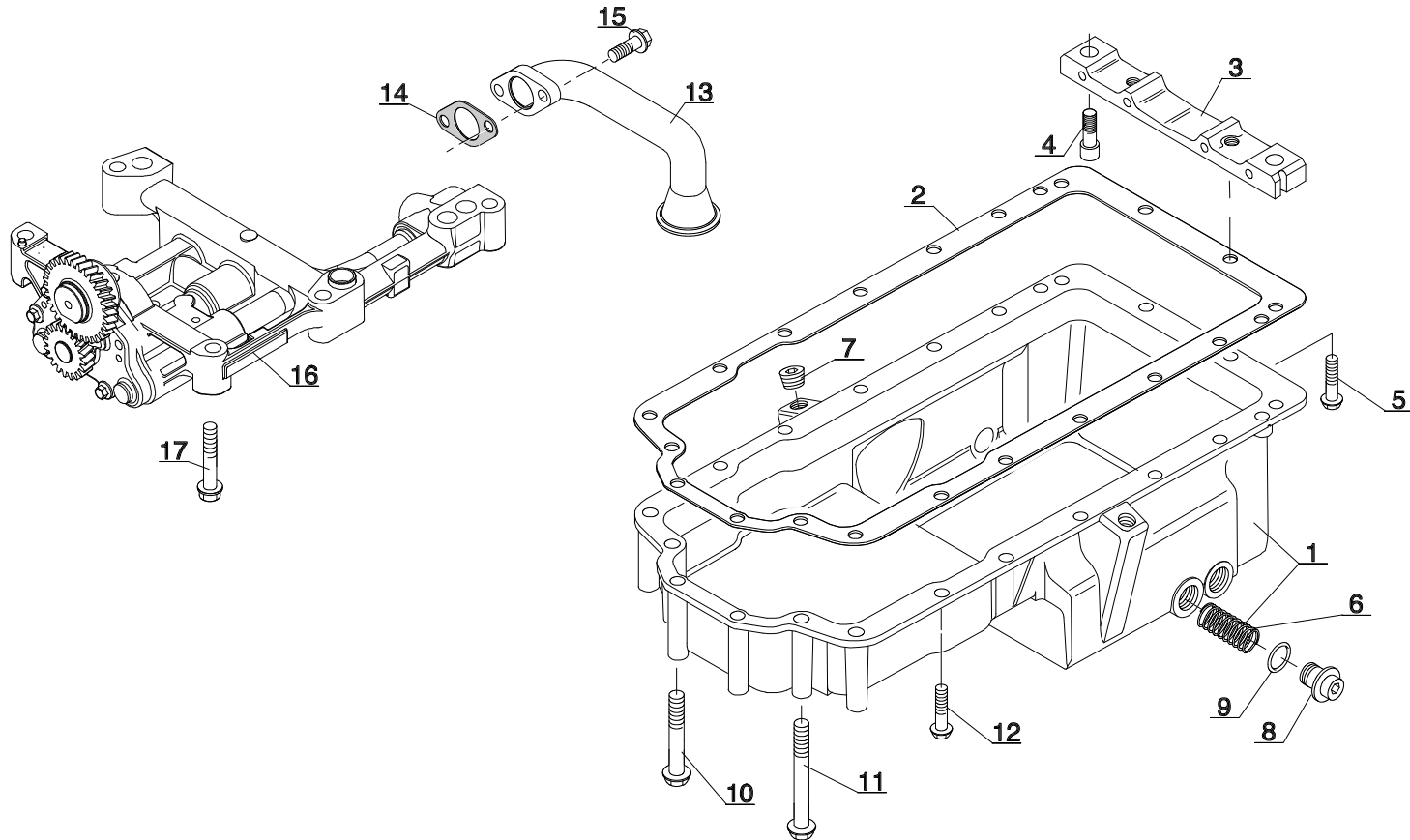

1	ENGINE, OIL PUMP AND PAN		QUANTITY / MODEL											AP 1955			
			M30-4T	M40-4T	M50-4T		M30-4T H	M40-4T H	M50-4T H		M30-4T L	M40-4T L	M50-4T L		M30-4T HL	M40-4T HL	M50-4T HL
ITEM	PART NO.	DESCRIPTION	M30-2T	M40-2T	M50-2T		M30-2T H	M40-2T H	M50-2T H		M30-2T L	M40-2T L	M50-2T L		M30-2T HL	M40-2T HL	M50-2T HL
1	745076	Oil pan	1	1	1	1	1	1	1	1	1	1	1	1	1	1	1
2	702080	Gasket	1	1	1	1	1	1	1	1	1	1	1	1	1	1	1
3	604954	Bridge	1	1	1	1	1	1	1	1	1	1	1	1	1	1	1
4	474056	Screw	2	2	2	2	2	2	2	2	2	2	2	2	2	2	2
5	473955	Screw	2	2	2	2	2	2	2	2	2	2	2	2	2	2	2
6	139495	Spring	2	2	2	2	2	2	2	2	2	2	2	2	2	2	2
7	548898	Plug	1	1	1	1	1	1	1	1	1	1	1	1	1	1	1
8	473309	Plug	2	2	2	2	2	2	2	2	2	2	2	2	2	2	2
9	474129	O-ring	2	2	2	2	2	2	2	2	2	2	2	2	2	2	2
10	475201	Screw	4	4	4	4	4	4	4	4	4	4	4	4	4	4	4
12	107363	Screw	12	12	12	12	12	12	12	12	12	12	12	12	12	12	12
13	702291	Pipe	1	1	1	1	1	1	1	1	1	1	1	1	1	1	1
14	477781	Seal	1	1	1	1	1	1	1	1	1	1	1	1	1	1	1
15	473986	Screw	2	2	2	2	2	2	2	2	2	2	2	2	2	2	2
16	702008	Oil pump	1	1	1	1	1	1	1	1	1	1	1	1	1	1	1
17	473988	Screw	1	1	1	1	1	1	1	1	1	1	1	1	1	1	1

AP 1956
TIER III

ENGINE, ROCKER ARM COVER AND BREATHER

M30-2T	M30-4T	M30-2T H	M30-4T H
M40-2T	M40-4T	M40-2T H	M40-4T H
M50-2T	M50-4T	M50-2T H	M50-4T H
M30-2T L	M30-4T L	M30-2T H L	M30-4T H L
M40-2T L	M40-4T L	M40-2T H L	M40-4T H L
M50-2T L	M50-4T L	M50-2T H L	M50-4T H L

NOTE: ENGINE COMPONENTS SHOWN ARE FOR PERKINS ENGINES.
FOR CAT ENGINE COMPONENTS CONTACT YOUR NEAREST CATERPILLAR DEALER.
FOR PERKINS COMPONENTS NOT FOUND IN THIS PARTS MANUAL CONTACT YOUR NEAREST PERKINS DEALER.

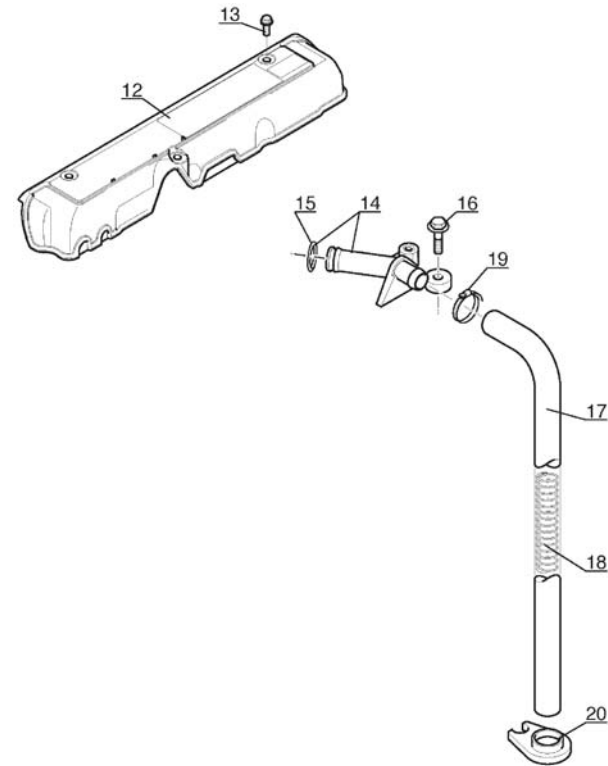
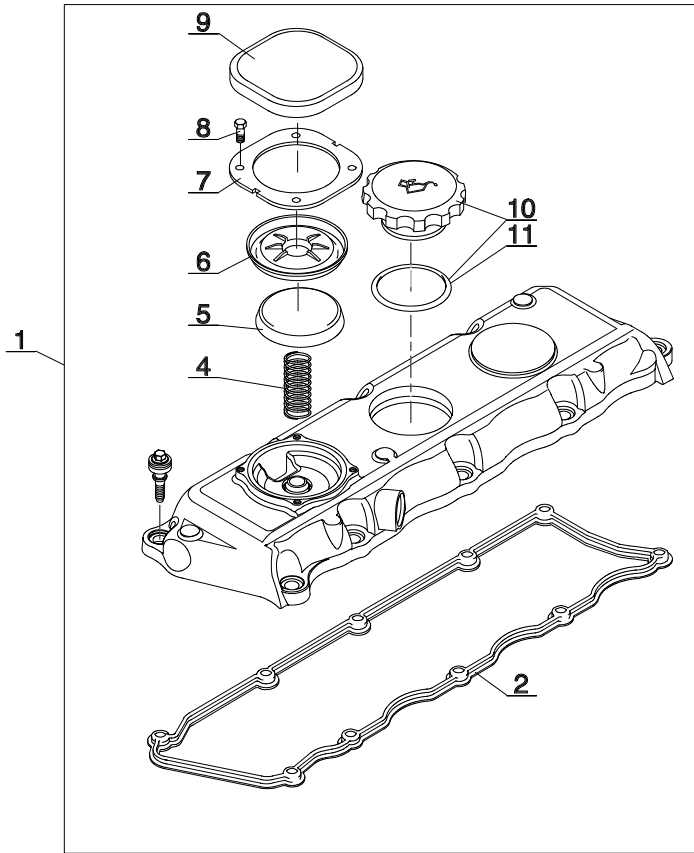

1	ENGINE, ROCKER ARM COVER AND BREATHER		QUANTITY / MODEL											AP 1956			
			M30-4T	M40-4T	M50-4T		M30-4T H	M40-4T H	M50-4T H		M30-4T L	M40-4T L	M50-4T L		M30-4T HL	M40-4T HL	M50-4T HL
ITEM	PART NO.	DESCRIPTION	M30-2T	M40-2T	M50-2T		M30-2T H	M40-2T H	M50-2T H		M30-2T L	M40-2T L	M50-2T L		M30-2T HL	M40-2T HL	M50-2T HL
1	744839	Rocker arm cover, complete	1	1	1	1	1	1	1	1	1	1	1	1	1	1	1
2	604958	Seal	1	1	1	1	1	1	1	1	1	1	1	1	1	1	1
4	604960	Spring	1	1	1	1	1	1	1	1	1	1	1	1	1	1	1
5	604961	Plug	1	1	1	1	1	1	1	1	1	1	1	1	1	1	1
6	604962	Diaphragm	1	1	1	1	1	1	1	1	1	1	1	1	1	1	1
7	604963	Fastening plate	1	1	1	1	1	1	1	1	1	1	1	1	1	1	1
8	604964	Screw	4	4	4	4	4	4	4	4	4	4	4	4	4	4	4
9	604965	Cover	1	1	1	1	1	1	1	1	1	1	1	1	1	1	1
10	550493	Filling plug	1	1	1	1	1	1	1	1	1	1	1	1	1	1	1
11	603891	O-ring	1	1	1	1	1	1	1	1	1	1	1	1	1	1	1
12	604966	Cover	1	1	1	1	1	1	1	1	1	1	1	1	1	1	1
13	474018	Screw	3	3	3	3	3	3	3	3	3	3	3	3	3	3	3
14	747621	Air breather	1	1	1	1	1	1	1	1	1	1	1	1	1	1	1
15	604969	O-ring	1	1	1	1	1	1	1	1	1	1	1	1	1	1	1
16	552894	Screw	2	2	2	2	2	2	2	2	2	2	2	2	2	2	2
17	702010	Hose	1	1	1	1	1	1	1	1	1	1	1	1	1	1	1
18	563506	Spring	1	1	1	1	1	1	1	1	1	1	1	1	1	1	1
19	550499	Clamp	1	1	1	1	1	1	1	1	1	1	1	1	1	1	1
20	474124	Bracket	1	1	1	1	1	1	1	1	1	1	1	1	1	1	1

88.00

AP 1957
TIER III

ENGINE, OIL FILTER BRACKET

M30-2T	M30-4T	M30-2T H	M30-4T H
M40-2T	M40-4T	M40-2T H	M40-4T H
M50-2T	M50-4T	M50-2T H	M50-4T H
M30-2T L	M30-4T L	M30-2T H L	M30-4T H L
M40-2T L	M40-4T L	M40-2T H L	M40-4T H L
M50-2T L	M50-4T L	M50-2T H L	M50-4T H L

NOTE: ENGINE COMPONENTS SHOWN ARE FOR PERKINS ENGINES.
FOR CAT ENGINE COMPONENTS CONTACT YOUR NEAREST CATERPILLAR DEALER.
FOR PERKINS COMPONENTS NOT FOUND IN THIS PARTS MANUAL CONTACT YOUR NEAREST PERKINS DEALER.

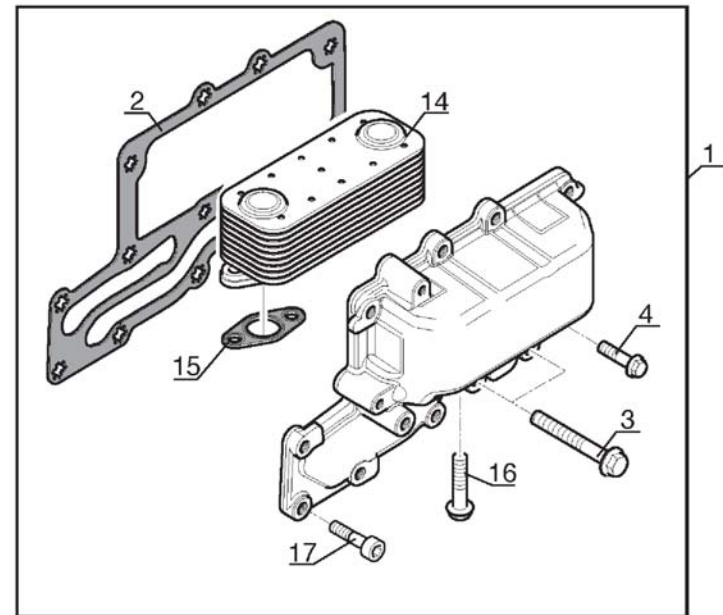
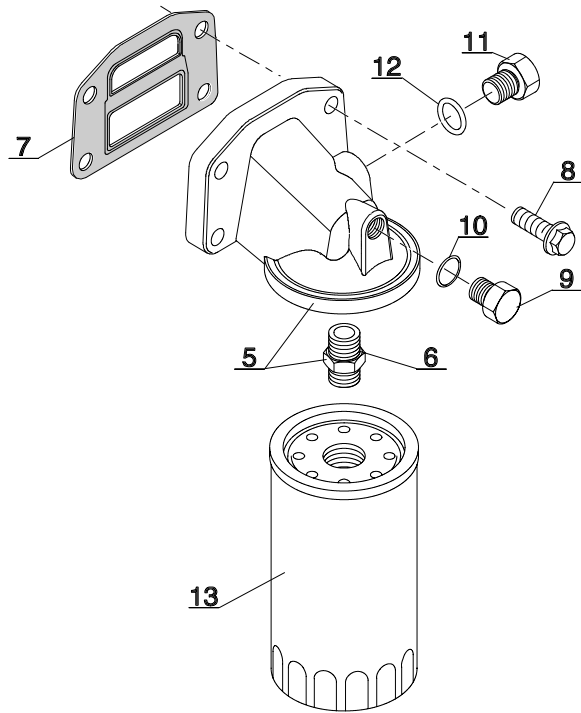

1	ENGINE, OIL FILTER BRACKET		QUANTITY / MODEL												AP 1957			
			M30-4T	M40-4T	M50-4T		M30-4T H	M40-4T H	M50-4T H		M30-4T L	M40-4T L	M50-4T L		M30-4T HL	M40-4T HL	M50-4T HL	
			M30-2T	M40-2T	M50-2T		M30-2T H	M40-2T H	M50-2T H		M30-2T L	M40-2T L	M50-2T L		M30-2T HL	M40-2T HL	M50-2T HL	
ITEM	PART NO.	DESCRIPTION	M30-2T	M40-2T	M50-2T		M30-2T H	M40-2T H	M50-2T H		M30-2T L	M40-2T L	M50-2T L		M30-2T HL	M40-2T HL	M50-2T HL	
1	745800	Oil cooler	1	1	1	1	1	1	1	1	1	1	1	1	1	1	1	1
2	706970	Gasket	1	1	1	1	1	1	1	1	1	1	1	1	1	1	1	1
3	476018	Screw	3	3	3	3	3	3	3	3	3	3	3	3	3	3	3	3
4	473986	Screw	8	8	8	8	8	8	8	8	8	8	8	8	8	8	8	8
5	705459	Filter head	1	1	1	1	1	1	1	1	1	1	1	1	1	1	1	1
6	550507	Connection	1	1	1	1	1	1	1	1	1	1	1	1	1	1	1	1
7	604973	Gasket	1	1	1	1	1	1	1	1	1	1	1	1	1	1	1	1
8	474005	Screw	4	4	4	4	4	4	4	4	4	4	4	4	4	4	4	4
9	604974	Plug	1	1	1	1	1	1	1	1	1	1	1	1	1	1	1	1
10	604975	O-ring	1	1	1	1	1	1	1	1	1	1	1	1	1	1	1	1
11	604976	Plug	1	1	1	1	1	1	1	1	1	1	1	1	1	1	1	1
12	604977	O-ring	1	1	1	1	1	1	1	1	1	1	1	1	1	1	1	1
13	476954	Oil filter	1	1	1	1	1	1	1	1	1	1	1	1	1	1	1	1
14	702012	Oil cooler	1	1	1	1	1	1	1	1	1	1	1	1	1	1	1	1
15	702013	Seal	2	2	2	2	2	2	2	2	2	2	2	2	2	2	2	2
16	473951	Screw	4	4	4	4	4	4	4	4	4	4	4	4	4	4	4	4
17	475986	Screw	2	2	2	2	2	2	2	2	2	2	2	2	2	2	2	2

89.00

AP 1958
TIER III

ENGINE, CYLINDER HEAD OUTLETS

M30-2T	M30-4T	M30-2T H	M30-4T H
M40-2T	M40-4T	M40-2T H	M40-4T H
M50-2T	M50-4T	M50-2T H	M50-4T H
M30-2T L	M30-4T L	M30-2T H L	M30-4T H L
M40-2T L	M40-4T L	M40-2T H L	M40-4T H L
M50-2T L	M50-4T L	M50-2T H L	M50-4T H L

NOTE: ENGINE COMPONENTS SHOWN ARE FOR PERKINS ENGINES.
FOR CAT ENGINE COMPONENTS CONTACT YOUR NEAREST CATERPILLAR DEALER.
FOR PERKINS COMPONENTS NOT FOUND IN THIS PARTS MANUAL CONTACT YOUR NEAREST PERKINS DEALER.

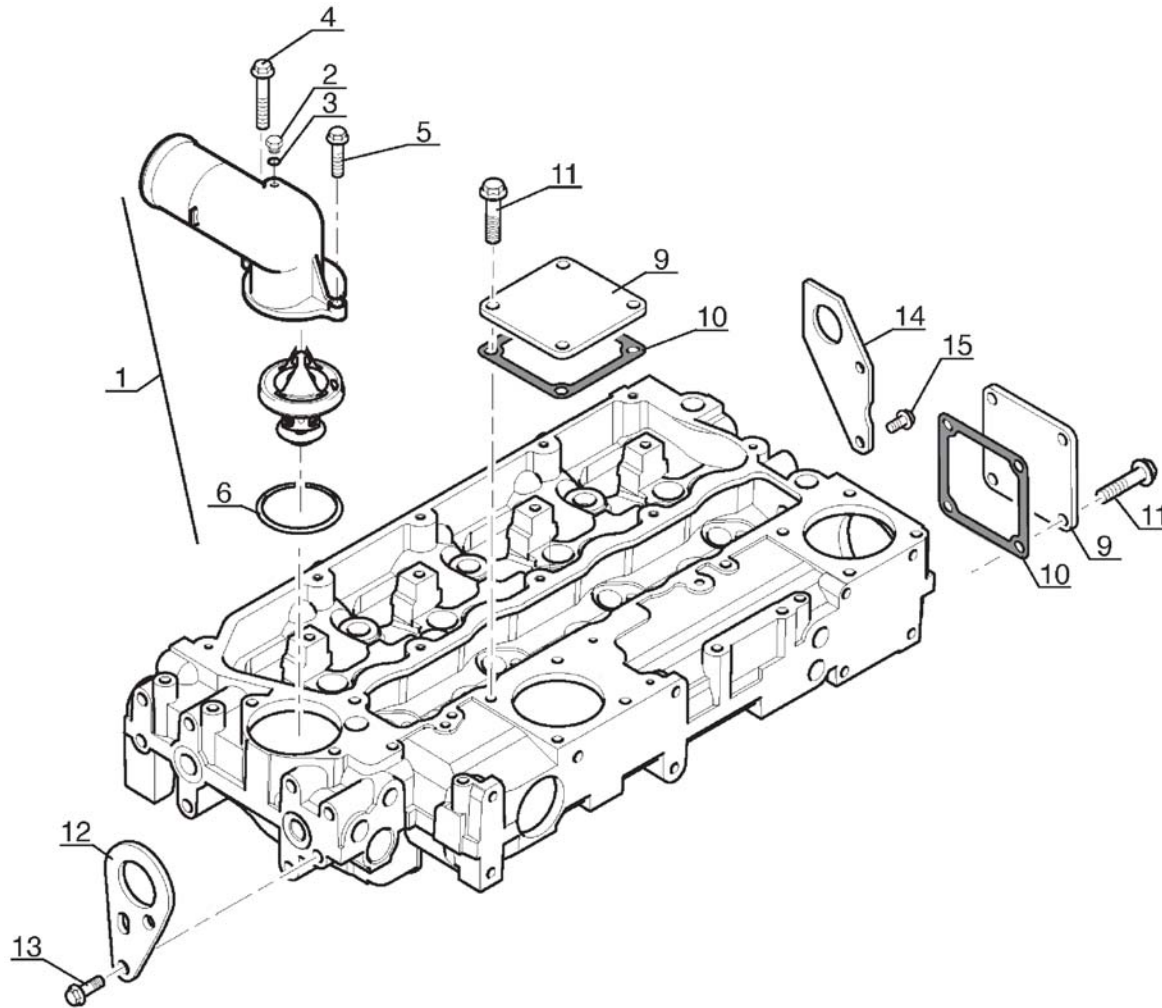

1	ENGINE, CYLINDER HEAD OUTLETS		QUANTITY / MODEL											AP 1958				
			M30-4T	M40-4T	M50-4T		M30-4T H	M40-4T H	M50-4T H		M30-4T L	M40-4T L	M50-4T L		M30-4T HL	M40-4T HL	M50-4T HL	
ITEM	PART NO.	DESCRIPTION	M30-2T	M40-2T	M50-2T		M30-2T H	M40-2T H	M50-2T H		M30-2T L	M40-2T L	M50-2T L		M30-2T HL	M40-2T HL	M50-2T HL	
1	704578	Water outlet kit	1	1	1	1	1	1	1	1	1	1	1	1	1	1	1	1
2	704937	Plug	1	1	1	1	1	1	1	1	1	1	1	1	1	1	1	1
3	704938	O-ring	1	1	1	1	1	1	1	1	1	1	1	1	1	1	1	1
4	476074	Screw	1	1	1	1	1	1	1	1	1	1	1	1	1	1	1	1
5	473986	Screw	1	1	1	1	1	1	1	1	1	1	1	1	1	1	1	1
6	704936	O-ring	1	1	1	1	1	1	1	1	1	1	1	1	1	1	1	1
9	564551	Fastening plate	2	2	2	2	2	2	2	2	2	2	2	2	2	2	2	2
10	473560	Gasket	2	2	2	2	2	2	2	2	2	2	2	2	2	2	2	2
11	474105	Screw	8	8	8	8	8	8	8	8	8	8	8	8	8	8	8	8
12	604986	Lug	1	1	1	1	1	1	1	1	1	1	1	1	1	1	1	1
13	473943	Screw	2	2	2	2	2	2	2	2	2	2	2	2	2	2	2	2
14	702660	Lug	1	1	1	1	1	1	1	1	1	1	1	1	1	1	1	1
15	473943	Screw	2	2	2	2	2	2	2	2	2	2	2	2	2	2	2	2

90.00

AP 1959
TIER III

ENGINE, WATERPUMP

M30-2T	M30-4T	M30-2T H	M30-4T H
M40-2T	M40-4T	M40-2T H	M40-4T H
M50-2T	M50-4T	M50-2T H	M50-4T H
M30-2T L	M30-4T L	M30-2T H L	M30-4T H L
M40-2T L	M40-4T L	M40-2T H L	M40-4T H L
M50-2T L	M50-4T L	M50-2T H L	M50-4T H L

NOTE: ENGINE COMPONENTS SHOWN ARE FOR PERKINS ENGINES.
FOR CAT ENGINE COMPONENTS CONTACT YOUR NEAREST CATERPILLAR DEALER.
FOR PERKINS COMPONENTS NOT FOUND IN THIS PARTS MANUAL CONTACT YOUR NEAREST PERKINS DEALER.

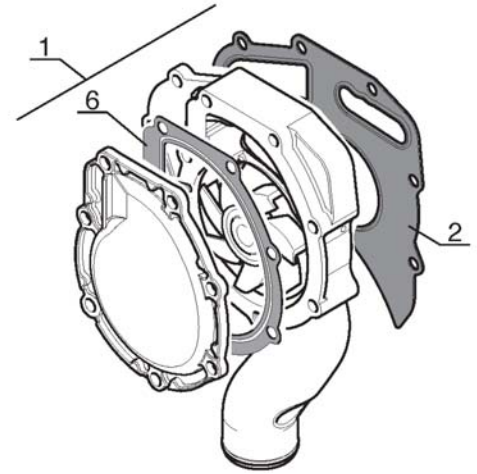
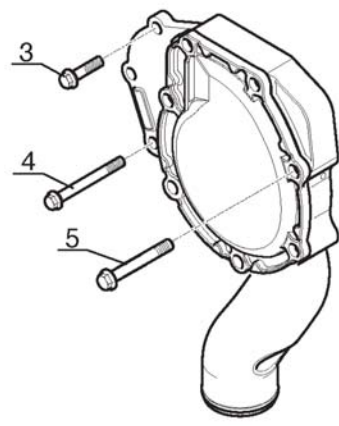
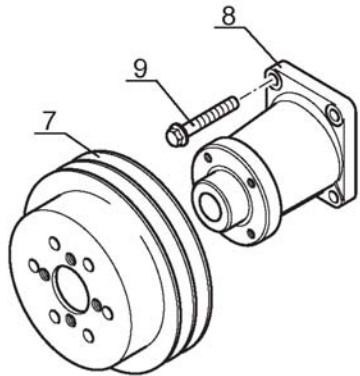

1	ENGINE, CYLINDER OUTLETS		QUANTITY / MODEL												AP 1959		
			M30-4T	M40-4T	M50-4T		M30-4T H	M40-4T H	M50-4T H		M30-4T L	M40-4T L	M50-4T L		M30-4T HL	M40-4T HL	M50-4T HL
ITEM	PART NO.	DESCRIPTION	M30-2T	M40-2T	M50-2T		M30-2T H	M40-2T H	M50-2T H		M30-2T L	M40-2T L	M50-2T L		M30-2T HL	M40-2T HL	M50-2T HL
1	747622	Waterpump	1	1	1	1	1	1	1	1	1	1	1	1	1	1	1
2	604988	Gasket	1	1	1	1	1	1	1	1	1	1	1	1	1	1	1
3	473982	Screw	2	2	2	2	2	2	2	2	2	2	2	2	2	2	2
4	475057	Screw	2	2	2	2	2	2	2	2	2	2	2	2	2	2	2
5	476074	Screw	5	5	5	5	5	5	5	5	5	5	5	5	5	5	5
6	704546	Seal	1	1	1	1	1	1	1	1	1	1	1	1	1	1	1
7	552418	Pulley	1	1	1	1	1	1	1	1	1	1	1	1	1	1	1
8	702762	Pulley bracket	1	1	1	1	1	1	1	1	1	1	1	1	1	1	1
9	473290	Screw	4	4	4	4	4	4	4	4	4	4	4	4	4	4	4

91.00

AP 1960
TIER III

ENGINE, EXHAUST MANIFOLD

M30-2T	M30-4T	M30-2T H	M30-4T H
M40-2T	M40-4T	M40-2T H	M40-4T H
M50-2T	M50-4T	M50-2T H	M50-4T H

NOTE: ENGINE COMPONENTS SHOWN ARE FOR PERKINS ENGINES.
FOR CAT ENGINE COMPONENTS CONTACT YOUR NEAREST CATERPILLAR DEALER.
FOR PERKINS COMPONENTS NOT FOUND IN THIS PARTS MANUAL CONTACT YOUR NEAREST PERKINS DEALER.

M30-2T L	M30-4T L	M30-2T H L	M30-4T H L
M40-2T L	M40-4T L	M40-2T H L	M40-4T H L
M50-2T L	M50-4T L	M50-2T H L	M50-4T H L

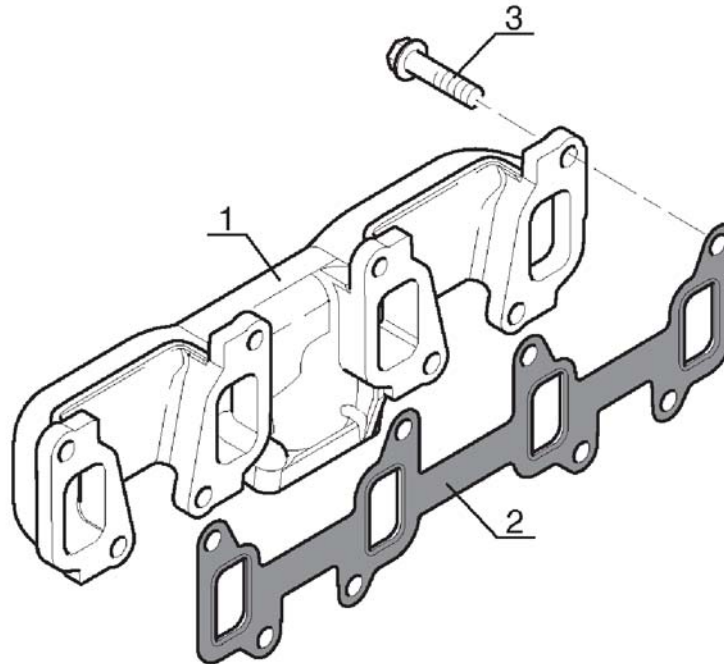

ITEM	PART NO.	DESCRIPTION	QUANTITY / MODEL												AP 1960			
			M30-2T	M40-2T	M50-2T		M30-2T H	M40-2T H	M50-2T H		M30-2T L	M40-2T L	M50-2T L		M30-2T HL	M40-2T HL	M50-2T HL	
1		ENGINE, EXHAUST MANIFOLD																
1	702336	Exhaust manifold	1	1	1	1	1	1	1	1	1	1	1	1	1	1	1	1
2	604997	Gasket	1	1	1	1	1	1	1	1	1	1	1	1	1	1	1	1
3	600716	Screw	8	8	8	8	8	8	8	8	8	8	8	8	8	8	8	8

92.00

AP 1961
TIER III

ALTERNATOR

M30-2T	M30-4T	M30-2T H	M30-4T H
M40-2T	M40-4T	M40-2T H	M40-4T H
M50-2T	M50-4T	M50-2T H	M50-4T H

NOTE: ENGINE COMPONENTS SHOWN ARE FOR PERKINS ENGINES.
FOR CAT ENGINE COMPONENTS CONTACT YOUR NEAREST CATERPILLAR DEALER.
FOR PERKINS COMPONENTS NOT FOUND IN THIS PARTS MANUAL CONTACT YOUR NEAREST PERKINS DEALER.

M30-2T L	M30-4T L	M30-2T H L	M30-4T H L
M40-2T L	M40-4T L	M40-2T H L	M40-4T H L
M50-2T L	M50-4T L	M50-2T H L	M50-4T H L

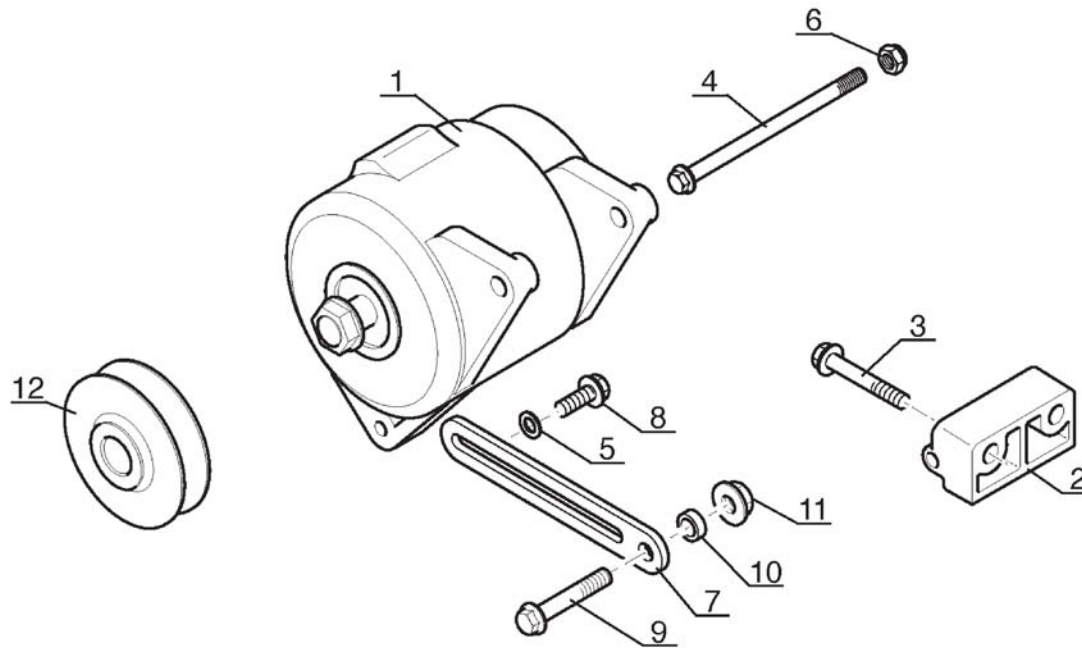

1	ALTERNATOR		QUANTITY / MODEL											AP 1961			
			M30-4T	M40-4T	M50-4T		M30-4T H	M40-4T H	M50-4T H		M30-4T L	M40-4T L	M50-4T L		M30-4T HL	M40-4T HL	M50-4T HL
ITEM	PART NO.	DESCRIPTION	M30-2T	M40-2T	M50-2T		M30-2T H	M40-2T H	M50-2T H		M30-2T L	M40-2T L	M50-2T L		M30-2T HL	M40-2T HL	M50-2T HL
1	702759	Alternator	1	1	1	1	1	1	1	1	1	1	1	1	1	1	1
2	604999	Bracket	1	1	1	1	1	1	1	1	1	1	1	1	1	1	1
3	605000	Screw	2	2	2	2	2	2	2	2	2	2	2	2	2	2	2
4	550482	Screw	1	1	1	1	1	1	1	1	1	1	1	1	1	1	1
5	133707	Washer	1	1	1	1	1	1	1	1	1	1	1	1	1	1	1
6	551662	Nut	1	1	1	1	1	1	1	1	1	1	1	1	1	1	1
7	605001	Lever	1	1	1	1	1	1	1	1	1	1	1	1	1	1	1
8	473986	Screw	1	1	1	1	1	1	1	1	1	1	1	1	1	1	1
9	563744	Screw	1	1	1	1	1	1	1	1	1	1	1	1	1	1	1
10	108564	Spacer	1	1	1	1	1	1	1	1	1	1	1	1	1	1	1
11	473969	Nut	1	1	1	1	1	1	1	1	1	1	1	1	1	1	1
12	605003	Pulley	1	1	1	1	1	1	1	1	1	1	1	1	1	1	1

93.00

AP 1962
TIER III

ENGINE, FLYWHEEL HOUSING

M30-2T	M30-4T	M30-2T H	M30-4T H
M40-2T	M40-4T	M40-2T H	M40-4T H
M50-2T	M50-4T	M50-2T H	M50-4T H
M30-2T L	M30-4T L	M30-2T H L	M30-4T H L
M40-2T L	M40-4T L	M40-2T H L	M40-4T H L
M50-2T L	M50-4T L	M50-2T H L	M50-4T H L

NOTE: ENGINE COMPONENTS SHOWN ARE FOR PERKINS ENGINES.
FOR CAT ENGINE COMPONENTS CONTACT YOUR NEAREST CATERPILLAR DEALER.
FOR PERKINS COMPONENTS NOT FOUND IN THIS PARTS MANUAL CONTACT YOUR NEAREST PERKINS DEALER.

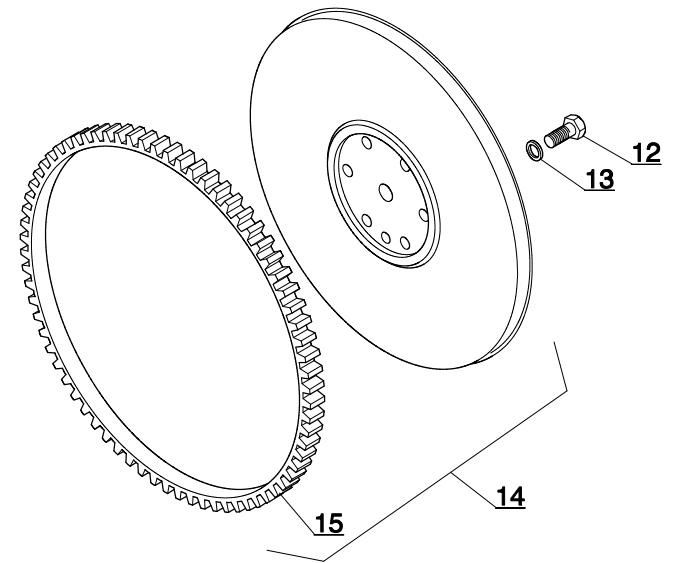
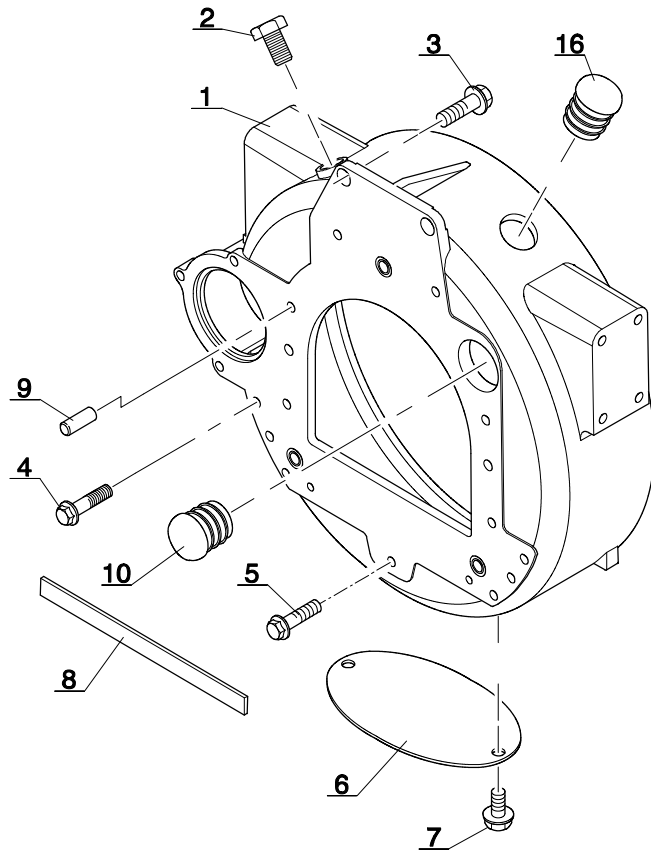

1	ENGINE, FLYWHEEL HOUSING		QUANTITY / MODEL											AP 1962				
			M30-4T	M40-4T	M50-4T		M30-4T H	M40-4T H	M50-4T H		M30-4T L	M40-4T L	M50-4T L		M30-4T HL	M40-4T HL	M50-4T HL	
ITEM	PART NO.	DESCRIPTION	M30-2T	M40-2T	M50-2T		M30-2T H	M40-2T H	M50-2T H		M30-2T L	M40-2T L	M50-2T L		M30-2T HL	M40-2T HL	M50-2T HL	
1	562567	Flywheel housing	1	1	1	1	1	1	1	1	1	1	1	1	1	1	1	1
2	473973	Plug	1	1	1	1	1	1	1	1	1	1	1	1	1	1	1	1
3	473975	Screw	2	2	2	2	2	2	2	2	2	2	2	2	2	2	2	2
4	473958	Screw	6	6	6	6	6	6	6	6	6	6	6	6	6	6	6	6
5	473976	Screw	3	3	3	3	3	3	3	3	3	3	3	3	3	3	3	3
6	473971	Sludge door	1	1	1	1	1	1	1	1	1	1	1	1	1	1	1	1
7	473972	Screw	2	2	2	2	2	2	2	2	2	2	2	2	2	2	2	2
8	107702	Cover	1	1	1	1	1	1	1	1	1	1	1	1	1	1	1	1
9	745999	Pin	2	2	2	2	2	2	2	2	2	2	2	2	2	2	2	2
10	601828	Plug	1	1	1	1	1	1	1	1	1	1	1	1	1	1	1	1
12	473299	Screw	6	6	6	6	6	6	6	6	6	6	6	6	6	6	6	6
13	473303	Washer	6	6	6	6	6	6	6	6	6	6	6	6	6	6	6	6
14	702619	Flywheel	1	1	1	1	1	1	1	1	1	1	1	1	1	1	1	1
15	138200	Gear	1	1	1	1	1	1	1	1	1	1	1	1	1	1	1	1
16	601829	Plug	1	1	1	1	1	1	1	1	1	1	1	1	1	1	1	1

AP 1963

TIER III

ENGINE, STARTER MOTOR

M30-2T	M30-4T	M30-2T H	M30-4T H
M40-2T	M40-4T	M40-2T H	M40-4T H
M50-2T	M50-4T	M50-2T H	M50-4T H

NOTE: ENGINE COMPONENTS SHOWN ARE FOR PERKINS ENGINES.
FOR CAT ENGINE COMPONENTS CONTACT YOUR NEAREST CATERPILLAR DEALER.
FOR PERKINS COMPONENTS NOT FOUND IN THIS PARTS MANUAL CONTACT YOUR NEAREST PERKINS DEALER.

M30-2T L	M30-4T L	M30-2T H L	M30-4T H L
M40-2T L	M40-4T L	M40-2T H L	M40-4T H L
M50-2T L	M50-4T L	M50-2T H L	M50-4T H L

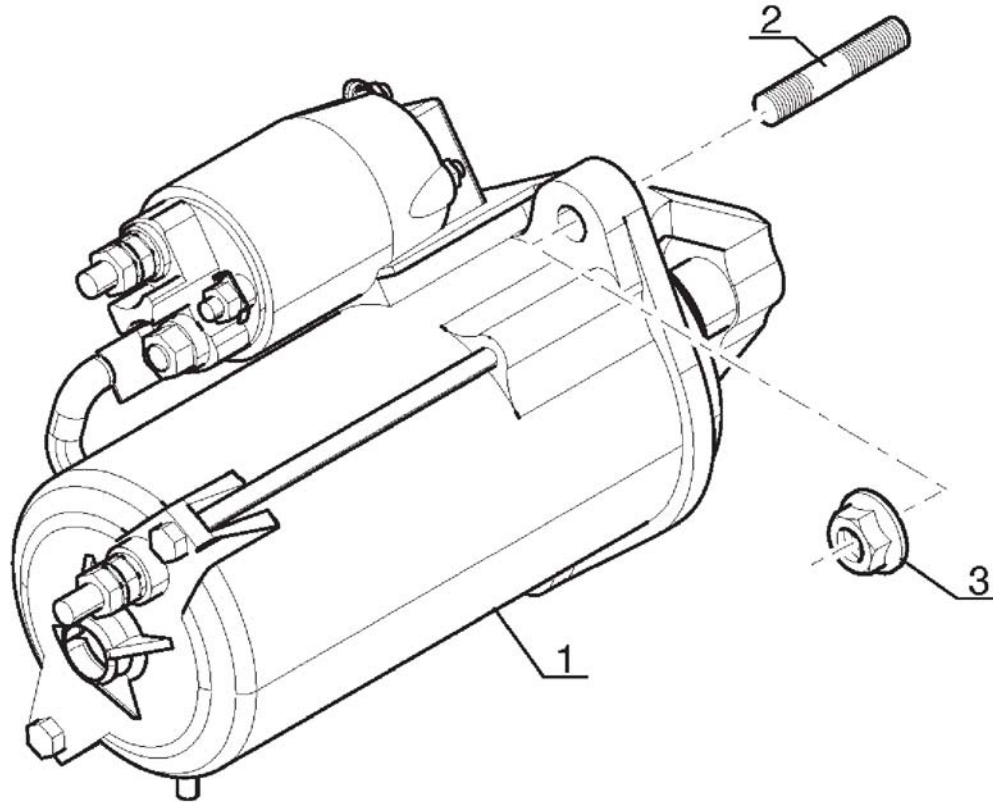

1	ENGINE, STARTER MOTOR			QUANTITY / MODEL												AP 1963		
				M30-4T	M40-4T	M50-4T		M30-4T H	M40-4T H	M50-4T H		M30-4T L	M40-4T L	M50-4T L		M30-4T HL	M40-4T HL	M50-4T HL
ITEM	PART NO.	DESCRIPTION	M30-2T	M40-2T	M50-2T		M30-2T H	M40-2T H	M50-2T H		M30-2T L	M40-2T L	M50-2T L		M30-2T HL	M40-2T HL	M50-2T HL	
1	781742	Starter motor	1	1	1	1	1	1	1	1	1	1	1	1	1	1	1	
2	476168	Stud bolt	3	3	3	3	3	3	3	3	3	3	3	3	3	3	3	
3	473969	Nut	3	3	3	3	3	3	3	3	3	3	3	3	3	3	3	

95.00

AP 1964
TIER III

ENGINE, TURBOCHARGER

M30-2T	M30-4T	M30-2T H	M30-4T H
M40-2T	M40-4T	M40-2T H	M40-4T H
M50-2T	M50-4T	M50-2T H	M50-4T H

M30-2T L	M30-4T L	M30-2T H L	M30-4T H L
M40-2T L	M40-4T L	M40-2T H L	M40-4T H L
M50-2T L	M50-4T L	M50-2T H L	M50-4T H L

NOTE: ENGINE COMPONENTS SHOWN ARE FOR PERKINS ENGINES.
FOR CAT ENGINE COMPONENTS CONTACT YOUR NEAREST CATERPILLAR DEALER.
FOR PERKINS COMPONENTS NOT FOUND IN THIS PARTS MANUAL CONTACT YOUR NEAREST PERKINS DEALER.

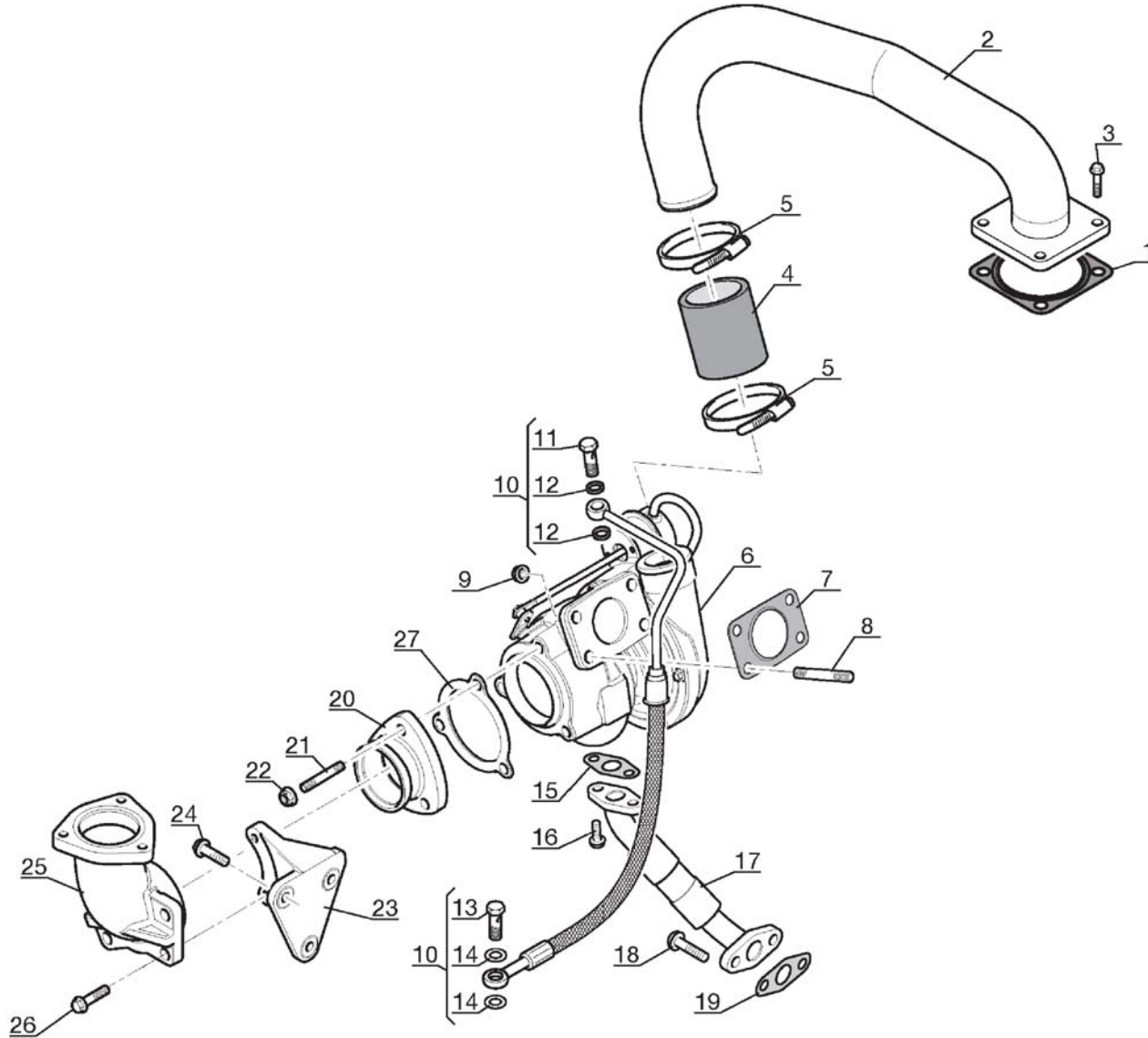

1	ENGINE, TURBOCHARGER		QUANTITY / MODEL											AP 1964			
			M30-4T	M40-4T	M50-4T		M30-4T H	M40-4T H	M50-4T H		M30-4T L	M40-4T L	M50-4T L		M30-4T HL	M40-4T HL	M50-4T HL
ITEM	PART NO.	DESCRIPTION	M30-2T	M40-2T	M50-2T		M30-2T H	M40-2T H	M50-2T H		M30-2T L	M40-2T L	M50-2T L		M30-2T HL	M40-2T HL	M50-2T HL
1	702017	Gasket	1	1	1	1	1	1	1	1	1	1	1	1	1	1	1
2	702335	Tube	1	1	1	1	1	1	1	1	1	1	1	1	1	1	1
3	473955	Screw	4	4	4	4	4	4	4	4	4	4	4	4	4	4	4
4	702019	Hose	1	1	1	1	1	1	1	1	1	1	1	1	1	1	1
5	702018	Clamp	2	2	2	2	2	2	2	2	2	2	2	2	2	2	2
6	748409	Turbocharger	1	1	1	1	1	1	1	1	1	1	1	1	1	1	1
7	601642	Gasket	1	1	1	1	1	1	1	1	1	1	1	1	1	1	1
8	702021	Stud	4	4	4	4	4	4	4	4	4	4	4	4	4	4	4
9	473908	Nut	4	4	4	4	4	4	4	4	4	4	4	4	4	4	4
10	702330	Hose	1	1	1	1	1	1	1	1	1	1	1	1	1	1	1
11	702024	Hollow screw	1	1	1	1	1	1	1	1	1	1	1	1	1	1	1
12	702023	Washer	2	2	2	2	2	2	2	2	2	2	2	2	2	2	2
13	702024	Hollow screw	1	1	1	1	1	1	1	1	1	1	1	1	1	1	1
14	702023	Washer	2	2	2	2	2	2	2	2	2	2	2	2	2	2	2
15	702026	Gasket	1	1	1	1	1	1	1	1	1	1	1	1	1	1	1
16	474067	Screw	2	2	2	2	2	2	2	2	2	2	2	2	2	2	2
17	702331	Hose	1	1	1	1	1	1	1	1	1	1	1	1	1	1	1
18	107363	Screw	2	2	2	2	2	2	2	2	2	2	2	2	2	2	2
19	702029	Gasket	1	1	1	1	1	1	1	1	1	1	1	1	1	1	1
20	746433	Adaptor	1	1	1	1	1	1	1	1	1	1	1	1	1	1	1
21	702021	Stud	3	3	3	3	3	3	3	3	3	3	3	3	3	3	3
22	473908	Nut	3	3	3	3	3	3	3	3	3	3	3	3	3	3	3
23	748455	Bracket	1	1	1	1	1	1	1	1	1	1	1	1	1	1	1
24	473956	Screw	3	3	3	3	3	3	3	3	3	3	3	3	3	3	3
25	702332	Connection	1	1	1	1	1	1	1	1	1	1	1	1	1	1	1
26	473958	Screw	2	2	2	2	2	2	2	2	2	2	2	2	2	2	2
27	702314	Seal	1	1	1	1	1	1	1	1	1	1	1	1	1	1	1

96.00

AP 1965
TIER III

ENGINE, FUEL CIRCUIT

M30-2T	M30-4T	M30-2T H	M30-4T H
M40-2T	M40-4T	M40-2T H	M40-4T H
M50-2T	M50-4T	M50-2T H	M50-4T H

NOTE: ENGINE COMPONENTS SHOWN ARE FOR PERKINS ENGINES.
FOR CAT ENGINE COMPONENTS CONTACT YOUR NEAREST CATERPILLAR DEALER.
FOR PERKINS COMPONENTS NOT FOUND IN THIS PARTS MANUAL CONTACT YOUR NEAREST PERKINS DEALER.

M30-2T L	M30-4T L	M30-2T H L	M30-4T H L
M40-2T L	M40-4T L	M40-2T H L	M40-4T H L
M50-2T L	M50-4T L	M50-2T H L	M50-4T H L

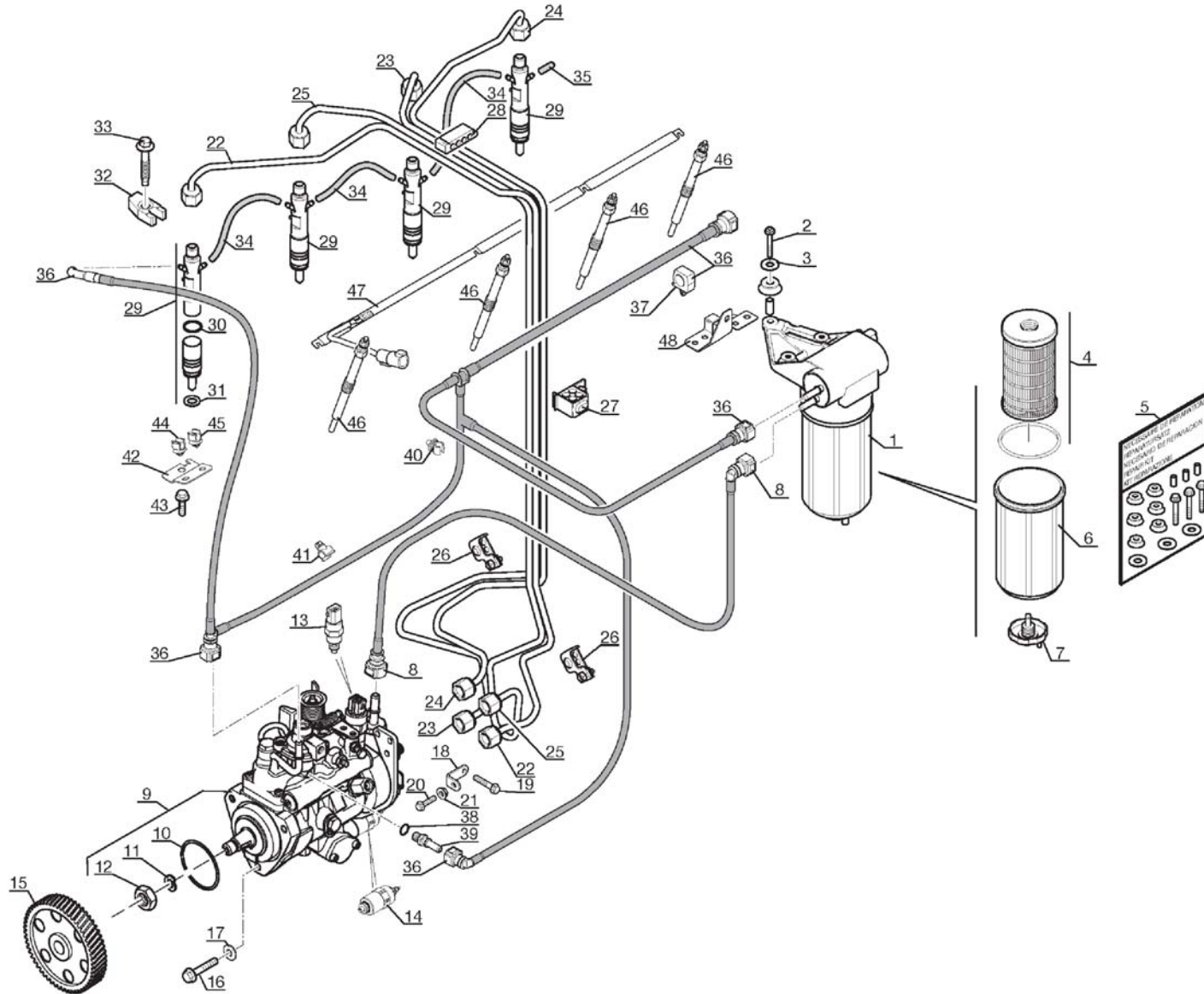

1	ENGINE, FUEL CIRCUIT											QUANTITY / MODEL									AP 1965					
												M30-4	M40-4	M50-4		M30-4 H	M40-4 H	M50-4 H		M30-4 L	M40-4 L	M50-4 L		M30-4 H L	M40-4 H L	M50-4 H L
												M30-2	M40-2	M50-2		M30-2 H	M40-2 H	M50-2 H		M30-2 L	M40-2 L	M50-2 L		M30-2 H L	M40-2 H L	M50-2 H L
ITEM	PART NO.	DESCRIPTION	M30-2	M40-2	M50-2		M30-2 H	M40-2 H	M50-2 H		M30-2 L	M40-2 L	M50-2 L		M30-2 H L	M40-2 H L	M50-2 H L									
1	746434	Fuel filter, complete	1	1	1	1	1	1	1	1	1	1	1	1	1	1	1									
2	747625	Screw	3	3	3	3	3	3	3	3	3	3	3	3	3	3	3									
3	605014	Washer	3	3	3	3	3	3	3	3	3	3	3	3	3	3	3									
4	605013	Filter	1	1	1	1	1	1	1	1	1	1	1	1	1	1	1									
5	747624	Repair kit	1	1	1	1	1	1	1	1	1	1	1	1	1	1	1									
6	706974	Tank	1	1	1	1	1	1	1	1	1	1	1	1	1	1	1									
7	706975	Bleeder screw	1	1	1	1	1	1	1	1	1	1	1	1	1	1	1									
8	702037	Hose	1	1	1	1	1	1	1	1	1	1	1	1	1	1	1									
9	747619	Injection pump	1	1	1	1	1	1	1	1	1	1	1	1	1	1	1									
10	563758	O-ring	1	1	1	1	1	1	1	1	1	1	1	1	1	1	1									
11	551859	Washer	1	1	1	1	1	1	1	1	1	1	1	1	1	1	1									
12	551858	Nut	1	1	1	1	1	1	1	1	1	1	1	1	1	1	1									
13	601673	Electrovalve	1	1	1	1	1	1	1	1	1	1	1	1	1	1	1									
14	705991	Electrovalve	1	1	1	1	1	1	1	1	1	1	1	1	1	1	1									
15	702039	Gear	1	1	1	1	1	1	1	1	1	1	1	1	1	1	1									
16	473986	Screw	3	3	3	3	3	3	3	3	3	3	3	3	3	3	3									
17	605019	Washer	6	6	6	6	6	6	6	6	6	6	6	6	6	6	6									
18	605021	Fastening lug	1	1	1	1	1	1	1	1	1	1	1	1	1	1	1									
19	473943	Screw	1	1	1	1	1	1	1	1	1	1	1	1	1	1	1									
20	107363	Screw	1	1	1	1	1	1	1	1	1	1	1	1	1	1	1									
21	473939	Nut	1	1	1	1	1	1	1	1	1	1	1	1	1	1	1									
22	702733	Injection tube no. 1	1	1	1	1	1	1	1	1	1	1	1	1	1	1	1									
23	702735	Injection tube no. 3	1	1	1	1	1	1	1	1	1	1	1	1	1	1	1									
24	702736	Injection tube no. 4	1	1	1	1	1	1	1	1	1	1	1	1	1	1	1									
25	702734	Injection tube no. 2	1	1	1	1	1	1	1	1	1	1	1	1	1	1	1									
26	605026	Clamp	2	2	2	2	2	2	2	2	2	2	2	2	2	2	2									
27	702158	Clamp	1	1	1	1	1	1	1	1	1	1	1	1	1	1	1									
28	473950	Clamp	1	1	1	1	1	1	1	1	1	1	1	1	1	1	1									

97.00

AX 1851
TIER III

GEARBOX (HYDROSTATIC), 2-SPEED REDUCTION

M30-2T H	M30-4T H
M40-2T H	M40-4T H
M50-2T H	M50-4T H

M30-2T H L	M30-4T H L
M40-2T H L	M40-4T H L
M50-2T H L	M50-4T H L

INSTALLATION LOCATION VARIES

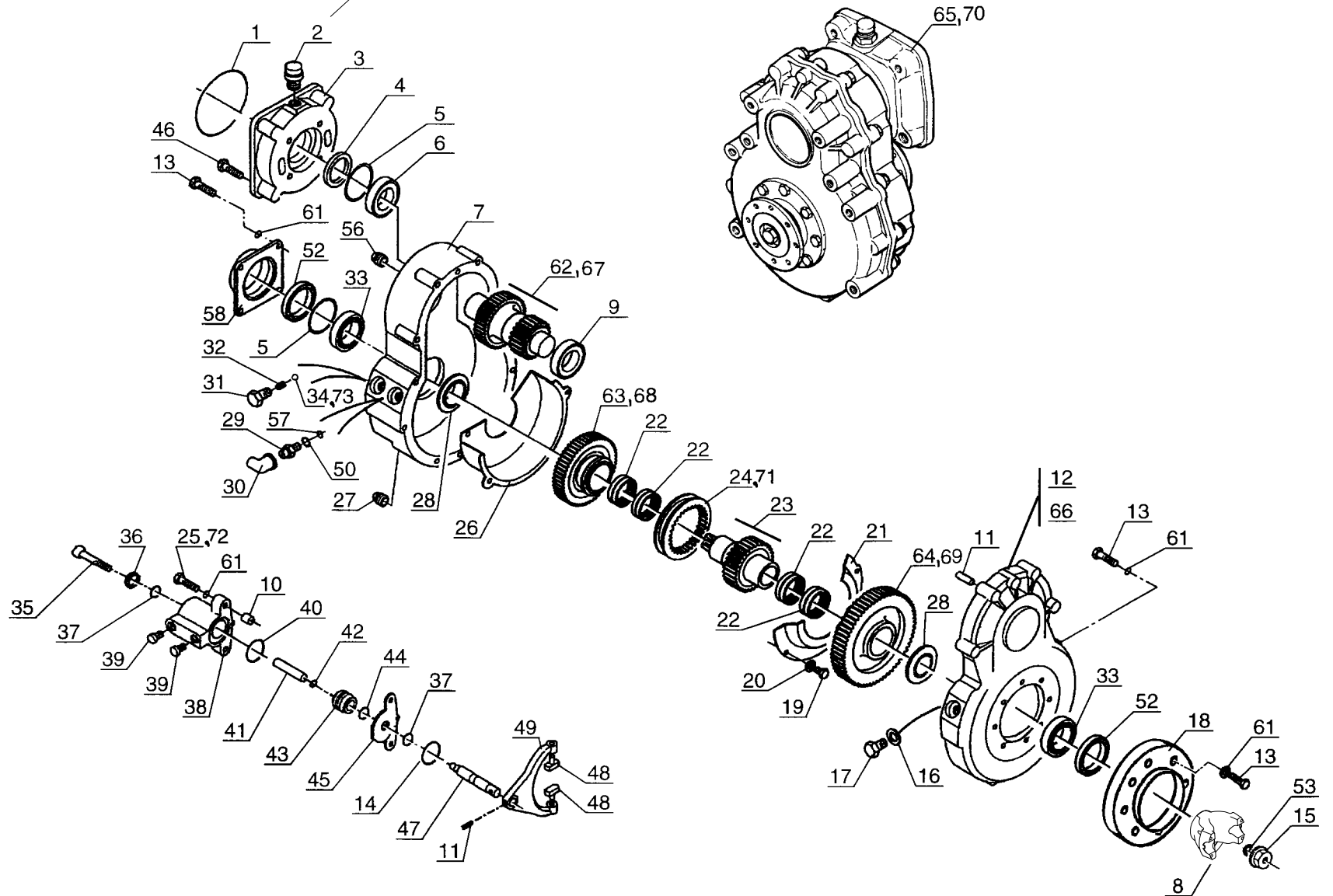

1	GEARBOX (HYDROSTATIC), 2-SPEED REDUCTION		QUANTITY / MODEL								AX 1851						
											M30-4T H	M40-4T H	M50-4T H		M30-4T HL	M40-4T HL	M50-4T HL
ITEM	PART NO.	DESCRIPTION								M30-2T H	M40-2T H	M50-2T H		M30-2T HL	M40-2T HL	M50-2T HL	
1	564073	O-ring								1	1	1	1	1	1	1	1
2	552524	Air breather								1	1	1	1	1	1	1	1
3	564076	Cover								1	1	1	1	1	1	1	1
4	552509	Seal								1	1	1	1	1	1	1	1
5	133136	Shim .10mm (.004 in.)								A/R	A/R	A/R	A/R	A/R	A/R	A/R	A/R
5	133138	Shim .30mm (.012 in.)								A/R	A/R	A/R	A/R	A/R	A/R	A/R	A/R
5	478022	Shim .40mm (.016 in.)								A/R	A/R	A/R	A/R	A/R	A/R	A/R	A/R
5	552515	Shim .15mm (.006 in.)								A/R	A/R	A/R	A/R	A/R	A/R	A/R	A/R
5	562427	Shim .20mm (.008 in.)								A/R	A/R	A/R	A/R	A/R	A/R	A/R	A/R
6	105101	Bearing								1	1	1	1	1	1	1	1
7	563497	Housing								1	1	1	1	1	1	1	1
8	564248	Flange								2	2	2	2	2	2	2	2
9	105491	Bearing								1	1	1	1	1	1	1	1
10	564223	Bushing								2	2	2	2	2	2	2	2
11	552518	Centering pin								3	3	3	3	3	3	3	3
12	600593	Cover (Gearbox Serial No. Z. ITA. 739546 and below)								1	1	1	1	1	1	1	1
13	106842	Screw								24	24	24	24	24	24	24	24
14	475059	O-ring								1	1	1	1	1	1	1	1
15	562485	Nut								2	2	2	2	2	2	2	2
16	552514	Washer								1	1	1	1	1	1	1	1
17	552522	Screw								1	1	1	1	1	1	1	1
18	600595	Cover								1	1	1	1	1	1	1	1
19	105131	Screw								2	2	2	2	2	2	2	2
20	133118	Washer								2	2	2	2	2	2	2	2
21	552538	Protective housing								1	1	1	1	1	1	1	1
22	552513	Roller bearing								4	4	4	4	4	4	4	4
23	600596	Output shaft								1	1	1	1	1	1	1	1

98.00

2	GEARBOX (HYDROSTATIC), 2-SPEED REDUCTION		QUANTITY / MODEL								AX 1851			
ITEM	PART NO.	DESCRIPTION	M30-2T H	M40-2T H	M50-2T H							M30-4T HL	M40-4T HL	M50-4T HL
24	601983	Change selector (GEARBOX 801992, 6K & 8K)	1	1								1	1	
25	133177	Screw (GEARBOX 801992, 6K & 8K)	2	2								2	2	
26	552537	Protective housing	1	1	1	1						1	1	1
27	133296	Magnetic plug	1	1	1	1						1	1	1
28	552531	Spacer	2	2	2	2						2	2	2
29	477475	Safety system switch	1	1	1	1						1	1	1
30	477476	Cap	1	1	1	1						1	1	1
31	564250	Screw	1	1	1	1						1	1	1
32	561947	Spring	1	1	1	1						1	1	1
33	133055	Bearing	2	2	2	2						2	2	2
34	133131	Ball (GEARBOX 801992, 6K & 8K)	1	1								1	1	
35	133187	Screw	1	1	1	1						1	1	1
36	552512	O-ring	1	1	1	1						1	1	1
37	563502	Seal	2	2	2	2						2	2	2
38	564245	Cylinder body	1	1	1	1						1	1	1
39	564226	Plug	2	2	2	2						2	2	2
40	564215	O-ring	1	1	1	1						1	1	1
41	564247	Cylinder rod	1	1	1	1						1	1	1
42	564216	O-ring	1	1	1	1						1	1	1
43	564246	Cylinder piston	1	1	1	1						1	1	1
44	564214	O-ring	1	1	1	1						1	1	1
45	563501	Protection plate	1	1	1	1						1	1	1
46	564074	Screw	4	4	4	4						4	4	4
47	564243	Rod	1	1	1	1						1	1	1

			QUANTITY / MODEL								AX 1851						
							M30-4T H	M40-4T H	M50-4T H					M30-4T HL	M40-4T HL	M50-4T HL	
3 GEARBOX (HYDROSTATIC), 2-SPEED REDUCTION							M30-2T H	M40-2T H	M50-2T H					M30-2T HL	M40-2T HL	M50-2T HL	
ITEM	PART NO.	DESCRIPTION					M30-2T H	M40-2T H	M50-2T H					M30-2T HL	M40-2T HL	M50-2T HL	
48	552523	Slide block					2	2	2	2				2	2	2	2
49	552532	Fork					1	1	1	1				1	1	1	1
50	477474	Seal					1	1	1	1				1	1	1	1
52	552510	Seal					2	2	2	2				2	2	2	2
53	133027	O-ring					2	2	2	2				2	2	2	2
56	133276	Plug					1	1	1	1				1	1	1	1
57	477473	O-ring					1	1	1	1				1	1	1	1
58	552528	Cover					1	1	1	1				1	1	1	1
61	108556	Washer					22	22	22	22				22	22	22	22
62	496430	Input shaft (GEARBOX 801992, 6K & 8K)					1	1						1	1		
63	564242	Gear (GEARBOX 801992, 6K & 8K)					1	1						1	1		
64	496431	Gear (GEARBOX 801992, 6K & 8K)					1	1						1	1		
65	801992	Complete reduction gearbox (6K & 8K)					1	1						1	1		
66	600594	Cover (Gearbox Serial No. Z. ITA. 739547 and above)					1	1	1	1				1	1	1	1
67	600598	Input shaft (GEARBOX 226148, 10K & 12K)							1	1						1	1
68	600600	Gear (GEARBOX 226148, 10K & 12K)							1	1						1	1
69	600599	Gear (GEARBOX 226148, 10K & 12K)							1	1						1	1
70	226148	Complete reduction gearbox (10K & 12K)							1	1						1	1
71	600597	Change selector (GEARBOX 226148, 10K & 12K)							1	1						1	1
72	564224	Screw (GEARBOX 226148, 10K & 12K)							2	2						2	2
73	564221	Ball (GEARBOX 226148, 10K & 12K)							1	1						1	1

AX 1867
TIER III

DRIVE AXLE, FRONT

M30-2T	M30-4T	M30-2T H	M30-4T H
M40-2T	M40-4T	M40-2T H	M40-4T H
M50-2T	M50-4T	M50-2T H	M50-4T H
M30-2T L	M30-4T L	M30-2T H L	M30-4T H L
M40-2T L	M40-4T L	M40-2T H L	M40-4T H L
M50-2T L	M50-4T L	M50-2T H L	M50-4T H L

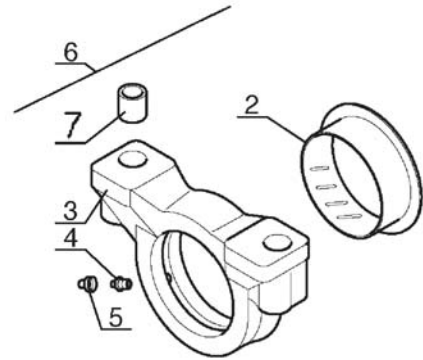
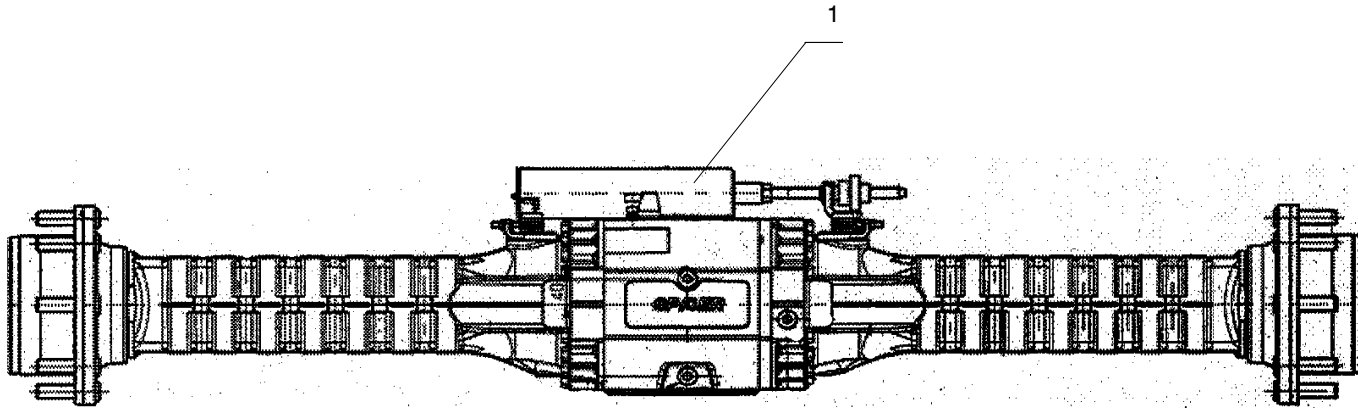

1	DRIVE AXLE, FRONT			QUANTITY / MODEL									AX 1867				
				M30-4T	M40-4T	M50-4T		M30-4T H	M40-4T H	M50-4T H		M30-4T L	M40-4T L	M50-4T L		M30-4T HL	M40-4T HL
ITEM	PART NO.	DESCRIPTION	M30-2T	M40-2T	M50-2T		M30-2T H	M40-2T H	M50-2T H		M30-2T L	M40-2T L	M50-2T L		M30-2T HL	M40-2T HL	M50-2T HL
1	807371	Drive axle, front	1	1	1	1	1	1	1								
1	807926	Drive axle, front (frame leveling only)									1	1	1	1	1	1	1
2	477538	Bushing (frame leveling only)									2	2	2	2	2	2	2
3	564693	Axle bracket (frame leveling only)									2	2	2	2	2	2	2
4	133103	Greaser (frame leveling only)									2	2	2	2	2	2	2
5	107796	Plug (frame leveling only)									2	2	2	2	2	2	2
6	601561	Axle bracket (frame leveling only)									2	2	2	2	2	2	2
7	477964	Coupling (frame leveling only)									2	2	2	2	2	2	2

99.00

AX 1868
TIER III

DRIVE AXLE, FRONT, CASING

M30-2T	M30-4T	M30-2T H	M30-4T H
M40-2T	M40-4T	M40-2T H	M40-4T H
M50-2T	M50-4T	M50-2T H	M50-4T H
M30-2T L	M30-4T L	M30-2T H L	M30-4T H L
M40-2T L	M40-4T L	M40-2T H L	M40-4T H L
M50-2T L	M50-4T L	M50-2T H L	M50-4T H L

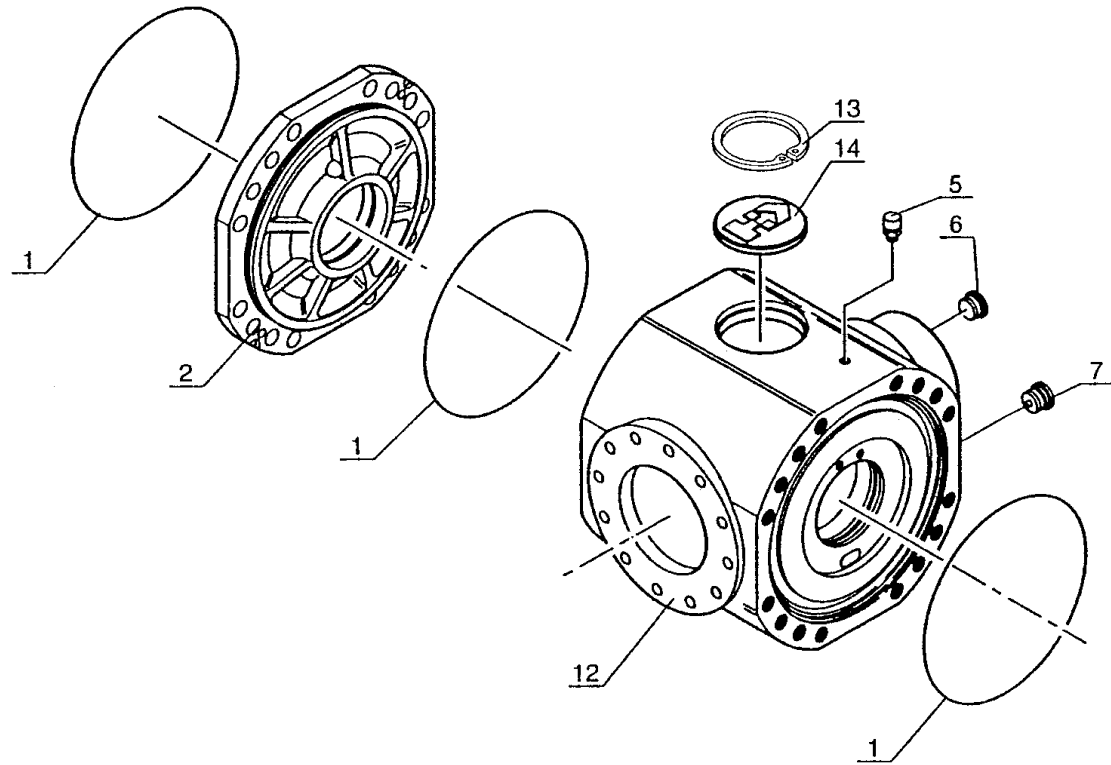

1	DRIVE AXLE, FRONT, CASING		QUANTITY / MODEL											AX 1868			
			M30-4T	M40-4T	M50-4T		M30-4T H	M40-4T H	M50-4T H		M30-4T L	M40-4T L	M50-4T L		M30-4T HL	M40-4T HL	M50-4T HL
ITEM	PART NO.	DESCRIPTION	M30-2T	M40-2T	M50-2T		M30-2T H	M40-2T H	M50-2T H		M30-2T L	M40-2T L	M50-2T L		M30-2T HL	M40-2T HL	M50-2T HL
1	106533	O-ring	3	3	3	3	3	3	3	3	3	3	3	3	3	3	3
2	562531	Housing	1	1	1	1	1	1	1	1	1	1	1	1	1	1	1
5	562470	Air breather	1	1	1	1	1	1	1	1	1	1	1	1	1	1	1
6	603638	Plug	1	1	1	1	1	1	1	1	1	1	1	1	1	1	1
7	603639	Magnetic plug	1	1	1	1	1	1	1	1							
7	702418	Magnetic plug (frame leveling only)									1	1	1	1	1	1	1
12	496425	Central casing	1	1	1	1	1	1	1	1							
12	807776	Central casing (frame leveling only)									1	1	1	1	1	1	1
13	133044	Circlip	1	1	1	1	1	1	1	1	1	1	1	1	1	1	1
14	602293	Plug	1	1	1	1	1	1	1	1							
14	600549	Plug (frame leveling only)									1	1	1	1	1	1	1

100.00

AX 1449
TIER III

DRIVE AXLE, FRONT, DIFFERENTIAL

M30-2T	M30-4T	M30-2T H	M30-4T H
M40-2T	M40-4T	M40-2T H	M40-4T H
M50-2T	M50-4T	M50-2T H	M50-4T H
M30-2T L	M30-4T L	M30-2T H L	M30-4T H L
M40-2T L	M40-4T L	M40-2T H L	M40-4T H L
M50-2T L	M50-4T L	M50-2T H L	M50-4T H L

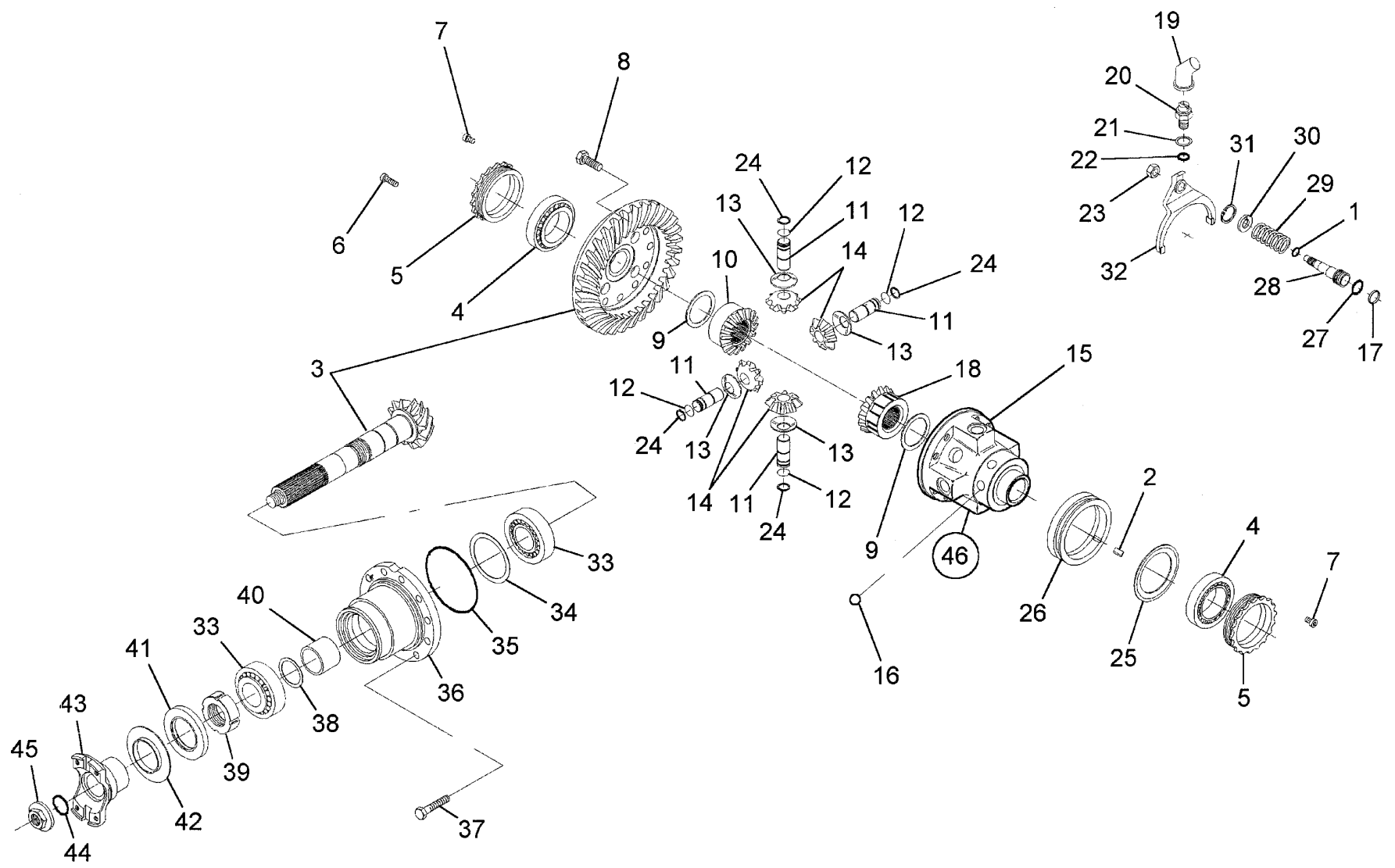

1	DRIVE AXLE, FRONT, DIFFERENTIAL		QUANTITY / MODEL												AX 1449		
			M30-4T	M40-4T	M50-4T		M30-4T H	M40-4T H	M50-4T H		M30-4T L	M40-4T L	M50-4T L		M30-4T HL	M40-4T HL	M50-4T HL
			M30-2T	M40-2T	M50-2T		M30-2T H	M40-2T H	M50-2T H		M30-2T L	M40-2T L	M50-2T L		M30-2T HL	M40-2T HL	M50-2T HL
ITEM	PART NO.	DESCRIPTION	M30-2T	M40-2T	M50-2T		M30-2T H	M40-2T H	M50-2T H		M30-2T L	M40-2T L	M50-2T L		M30-2T HL	M40-2T HL	M50-2T HL
1	601945	Circlip	1	1	1	1	1	1	1	1	1	1	1	1	1	1	1
2	601935	Key	1	1	1	1	1	1	1	1	1	1	1	1	1	1	1
3	601558	Bevel gear set	1	1	1	1	1	1	1	1	1	1	1	1	1	1	1
4	106550	Tapered roller bearing	2	2	2	2	2	2	2	2	2	2	2	2	2	2	2
5	562474	Ring nut	2	2	2	2	2	2	2	2	2	2	2	2	2	2	2
6	133186	Bolt	4	4	4	4	4	4	4	4	4	4	4	4	4	4	4
7	109912	Bolt	2	2	2	2	2	2	2	2	2	2	2	2	2	2	2
8	601243	Bolt	12	12	12	12	12	12	12	12	12	12	12	12	12	12	12
9	562476	Washer	2	2	2	2	2	2	2	2	2	2	2	2	2	2	2
10	562477	Differential side gear	2	2	2	2	2	2	2	2	2	2	2	2	2	2	2
11	562478	Pin	4	4	4	4	4	4	4	4	4	4	4	4	4	4	4
12	562479	Circlips	4	4	4	4	4	4	4	4	4	4	4	4	4	4	4
13	562480	Washer	4	4	4	4	4	4	4	4	4	4	4	4	4	4	4
14	562481	Differential pinion	4	4	4	4	4	4	4	4	4	4	4	4	4	4	4
15	603310	Differential carrier	1	1	1	1	1	1	1	1	1	1	1	1	1	1	1
16	601941	Detend ball	6	6	6	6	6	6	6	6	6	6	6	6	6	6	6
17	601943	Ring	1	1	1	1	1	1	1	1	1	1	1	1	1	1	1
18	601937	Differential side gear	1	1	1	1	1	1	1	1	1	1	1	1	1	1	1
19	603311	Boot	1	1	1	1	1	1	1	1	1	1	1	1	1	1	1
20	603303	Security switch	1	1	1	1	1	1	1	1	1	1	1	1	1	1	1
21	477474	Washer, lock	1	1	1	1	1	1	1	1	1	1	1	1	1	1	1
22	477473	O-ring	1	1	1	1	1	1	1	1	1	1	1	1	1	1	1
23	601949	Nut	1	1	1	1	1	1	1	1	1	1	1	1	1	1	1
24	562486	Circlips	4	4	4	4	4	4	4	4	4	4	4	4	4	4	4
25	603312	Sheet	1	1	1	1	1	1	1	1	1	1	1	1	1	1	1
26	601998	Selector	1	1	1	1	1	1	1	1	1	1	1	1	1	1	1
27	477693	O-ring	1	1	1	1	1	1	1	1	1	1	1	1	1	1	1
28	601944	Piston	1	1	1	1	1	1	1	1	1	1	1	1	1	1	1

101.00

AX 1450
TIER III

DRIVE AXLE, FRONT, REDUCTION GEAR

M30-2T	M30-4T	M30-2T H	M30-4T H
M40-2T	M40-4T	M40-2T H	M40-4T H
M50-2T	M50-4T	M50-2T H	M50-4T H
M30-2T L	M30-4T L	M30-2T H L	M30-4T H L
M40-2T L	M40-4T L	M40-2T H L	M40-4T H L
M50-2T L	M50-4T L	M50-2T H L	M50-4T H L

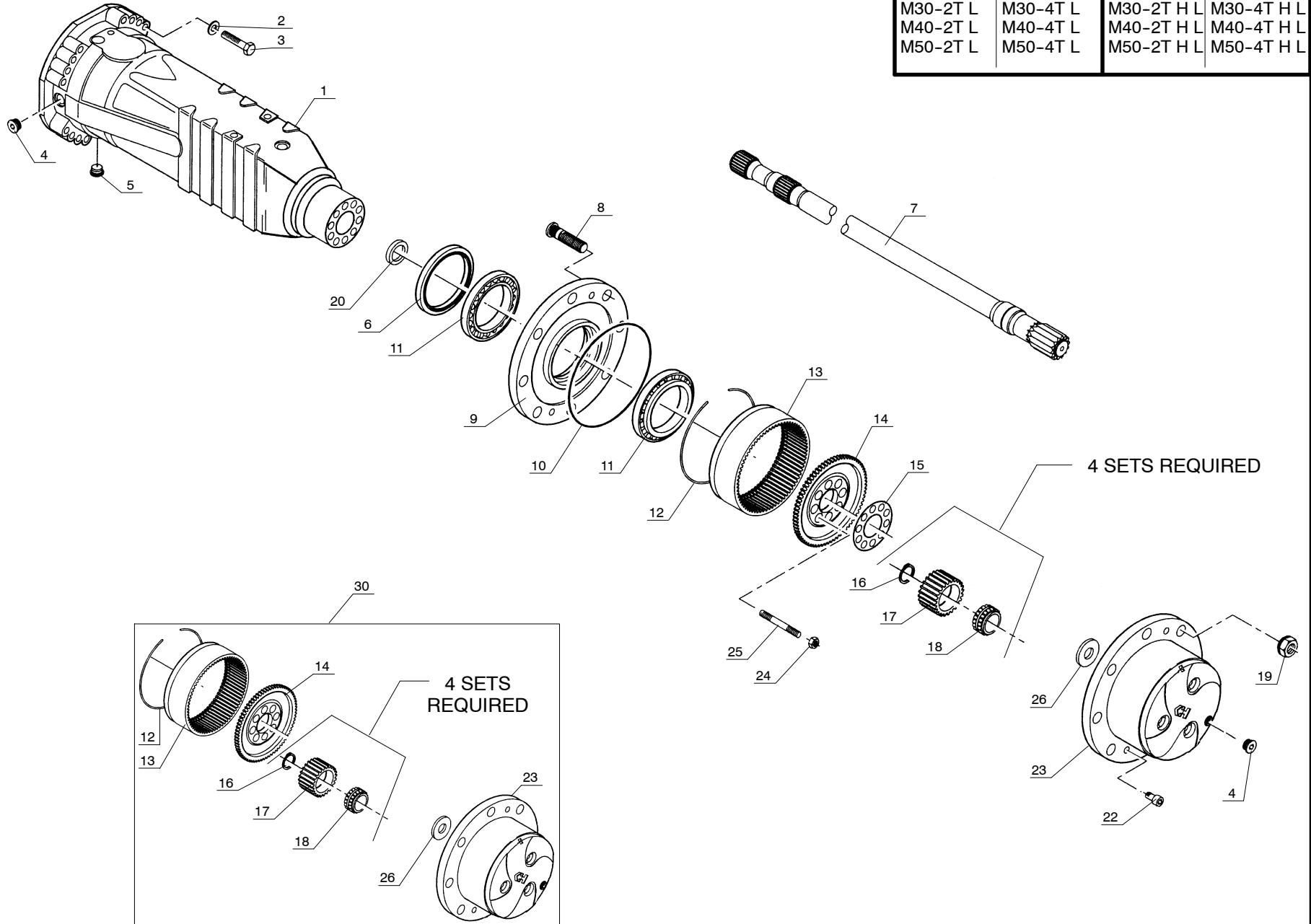

4 SETS REQUIRED

4 SETS
REQUIRED

1	DRIVE AXLE, FRONT, REDUCTION GEAR		QUANTITY / MODEL												AX 1450			
			M30-4T	M40-4T	M50-4T		M30-4T H	M40-4T H	M50-4T H		M30-4T L	M40-4T L	M50-4T L		M30-4T HL	M40-4T HL	M50-4T HL	
			M30-2T	M40-2T	M50-2T		M30-2T H	M40-2T H	M50-2T H		M30-2T L	M40-2T L	M50-2T L		M30-2T HL	M40-2T HL	M50-2T HL	
ITEM	PART NO.	DESCRIPTION	M30-2T	M40-2T	M50-2T		M30-2T H	M40-2T H	M50-2T H		M30-2T L	M40-2T L	M50-2T L		M30-2T HL	M40-2T HL	M50-2T HL	
1	602787	Lateral axel case	2	2	2	2	2	2	2	2	2	2	2	2	2	2	2	2
2	562490	Washer	32	32	32	32	32	32	32	32	32	32	32	32	32	32	32	32
3	702138	Bolt	32	32	32	32	32	32	32	32	32	32	32	32	32	32	32	32
4	603638	Plug	4	4	4	4	4	4	4	4	4	4	4	4	4	4	4	4
5	603639	Magnetic plug	2	2	2	2	2	2	2	2	2	2	2	2	2	2	2	2
6	604656	Seal	2	2	2	2	2	2	2	2	2	2	2	2	2	2	2	2
7	602788	Drive shaft	2	2	2	2	2	2	2	2	2	2	2	2	2	2	2	2
8	106080	Wheel stud	16	16	16	16	16	16	16	16	16	16	16	16	16	16	16	16
9	601246	Wheel hub	2	2	2	2	2	2	2	2	2	2	2	2	2	2	2	2
10	106533	O-ring	2	2	2	2	2	2	2	2	2	2	2	2	2	2	2	2
11	562504	Bearing	4	4	4	4	4	4	4	4	4	4	4	4	4	4	4	4
12	562514	Circlips	2	2	2	2	2	2	2	2	2	2	2	2	2	2	2	2
13	564133	Gear ring	2	2	2	2	2	2	2	2	2	2	2	2	2	2	2	2
14	565998	Ring gear bracket	2	2	2	2	2	2	2	2	2	2	2	2	2	2	2	2
15	562515	Locking plate	2	2	2	2	2	2	2	2	2	2	2	2	2	2	2	2
16	562508	Circlips	8	8	8	8	8	8	8	8	8	8	8	8	8	8	8	8
17	562509	Planet wheel	8	8	8	8	8	8	8	8	8	8	8	8	8	8	8	8
18	562510	Bearing	8	8	8	8	8	8	8	8	8	8	8	8	8	8	8	8
19	109480	Wheel nut	16	16	16	16	16	16	16	16	16	16	16	16	16	16	16	16
20	602789	Seal	2	2	2	2	2	2	2	2	2	2	2	2	2	2	2	2
22	600670	Screw	4	4	4	4	4	4	4	4	4	4	4	4	4	4	4	4
23	603316	Planet wheel bracket	2	2	2	2	2	2	2	2	2	2	2	2	2	2	2	2
24	562513	Nut	16	16	16	16	16	16	16	16	16	16	16	16	16	16	16	16
25	562512	Stud, bolt	16	16	16	16	16	16	16	16	16	16	16	16	16	16	16	16
26	603640	Washer	2	2	2	2	2	2	2	2	2	2	2	2	2	2	2	2
30	603317	Planet wheel bracket kit	2	2	2	2	2	2	2	2	2	2	2	2	2	2	2	2

AX 1415
TIER III

DRIVE AXLE, FRONT, DISC BRAKES

M30-2T	M30-4T	M30-2T H	M30-4T H
M40-2T	M40-4T	M40-2T H	M40-4T H
M50-2T	M50-4T	M50-2T H	M50-4T H
M30-2T L	M30-4T L	M30-2T H L	M30-4T H L
M40-2T L	M40-4T L	M40-2T H L	M40-4T H L
M50-2T L	M50-4T L	M50-2T H L	M50-4T H L

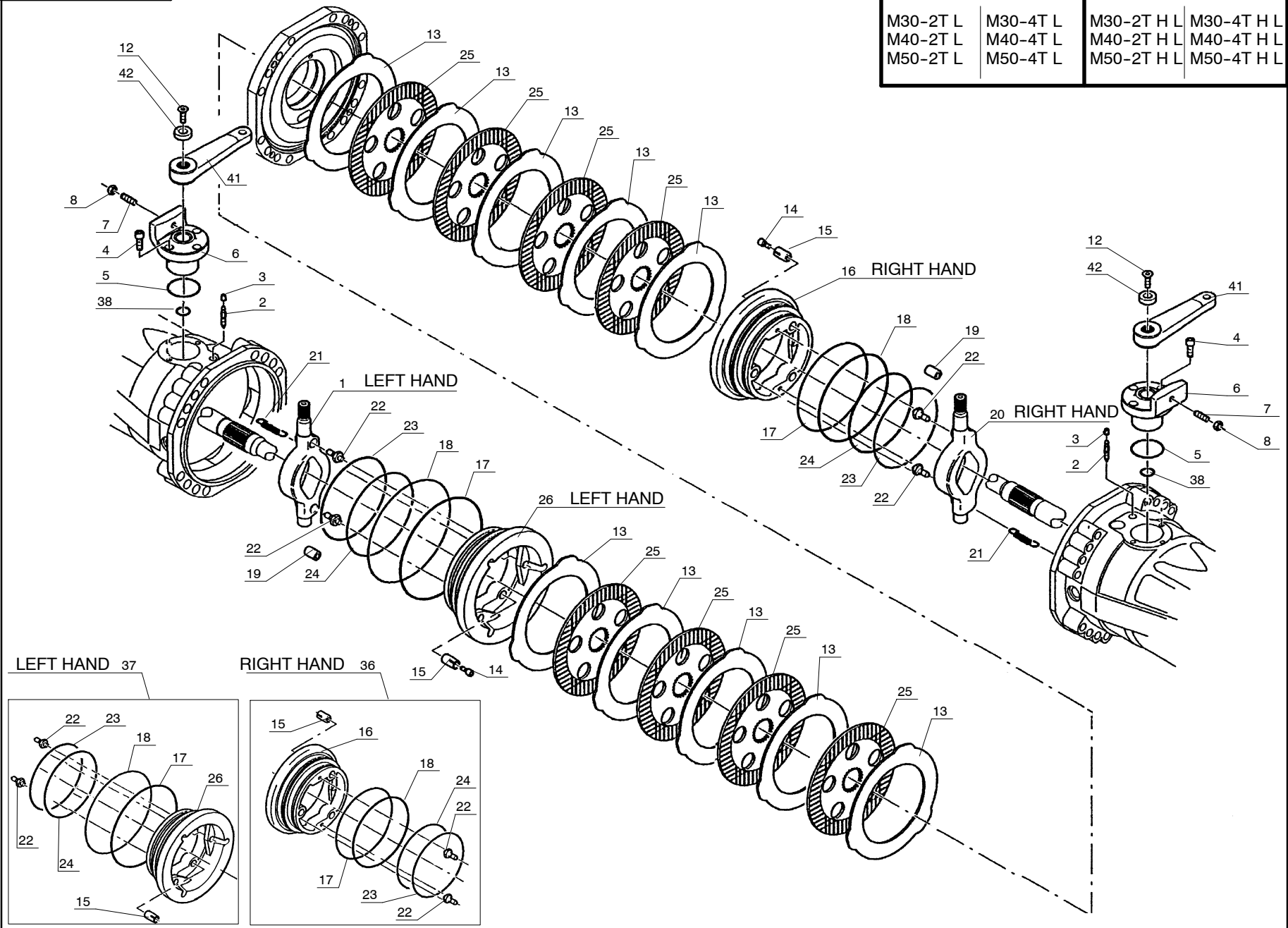

1	DRIVE AXLE, FRONT, DISC BRAKES											QUANTITY / MODEL						AX 1415		
	ITEM	PART NO.	DESCRIPTION	M30-4T	M40-4T	M50-4T		M30-4T H	M40-4T H	M50-4T H		M30-4T L	M40-4T L	M50-4T L		M30-4T HL	M40-4T HL	M50-4T HL		
				M30-2T	M40-2T	M50-2T		M30-2T H	M40-2T H	M50-2T H		M30-2T L	M40-2T L	M50-2T L		M30-2T HL	M40-2T HL	M50-2T HL		
1	562547	Lever, LH	1	1	1	1	1	1	1	1	1	1	1	1	1	1	1	1	1	
2	106010	Bleeder screw	2	2	2	2	2	2	2	2	2	2	2	2	2	2	2	2	2	
3	107796	Plug	2	2	2	2	2	2	2	2	2	2	2	2	2	2	2	2	2	
4	562548	Screw	6	6	6	6	6	6	6	6	6	6	6	6	6	6	6	6	6	
5	475059	O-ring	2	2	2	2	2	2	2	2	2	2	2	2	2	2	2	2	2	
6	602218	Reduction bushing	2	2	2	2	2	2	2	2	2	2	2	2	2	2	2	2	2	
7	562550	Needle valve	2	2	2	2	2	2	2	2	2	2	2	2	2	2	2	2	2	
8	133088	Nut	2	2	2	2	2	2	2	2	2	2	2	2	2	2	2	2	2	
12	133199	Screw	2	2	2	2	2	2	2	2	2	2	2	2	2	2	2	2	2	
13	562525	Intermediate disc	10	10	10	10	10	10	10	10	10	10	10	10	10	10	10	10	10	
14	564234	Adjusting screw	6	6	6	6	6	6	6	6	6	6	6	6	6	6	6	6	6	
15	602296	Spring	6	6	6	6	6	6	6	6	6	6	6	6	6	6	6	6	6	
16	563905	Piston	1	1	1	1	1	1	1	1	1	1	1	1	1	1	1	1	1	
17	562521	Anti-extrusion seal	2	2	2	2	2	2	2	2	2	2	2	2	2	2	2	2	2	
18	562522	O-ring	2	2	2	2	2	2	2	2	2	2	2	2	2	2	2	2	2	
19	107751	Centering pin	2	2	2	2	2	2	2	2	2	2	2	2	2	2	2	2	2	
20	562554	Lever, RH	1	1	1	1	1	1	1	1	1	1	1	1	1	1	1	1	1	
21	562520	Spring	6	6	6	6	6	6	6	6	6	6	6	6	6	6	6	6	6	
22	107286	Needle valve	4	4	4	4	4	4	4	4	4	4	4	4	4	4	4	4	4	
23	562523	Anti-extrusion seal	2	2	2	2	2	2	2	2	2	2	2	2	2	2	2	2	2	
24	562524	O-ring	2	2	2	2	2	2	2	2	2	2	2	2	2	2	2	2	2	
25	562516	Brake disc	8	8	8	8	8	8	8	8	8	8	8	8	8	8	8	8	8	
26	563906	Piston	1	1	1	1	1	1	1	1	1	1	1	1	1	1	1	1	1	
36	600582	Piston kit	1	1	1	1	1	1	1	1	1	1	1	1	1	1	1	1	1	
37	600558	Piston kit	1	1	1	1	1	1	1	1	1	1	1	1	1	1	1	1	1	
38	602007	O-ring	2	2	2	2	2	2	2	2	2	2	2	2	2	2	2	2	2	
41	604253	Lever	2	2	2	2	2	2	2	2	2	2	2	2	2	2	2	2	2	
42	106567	Spacer	2	2	2	2	2	2	2	2	2	2	2	2	2	2	2	2	2	

103.00

AX 2551
TIER III

STEER AXLE ASSEMBLY, 4WD, TORQUE CONVERTER MODELS

M30-4T
M40-4T
M50-4T

M30-4T L
M40-4T L
M50-4T L

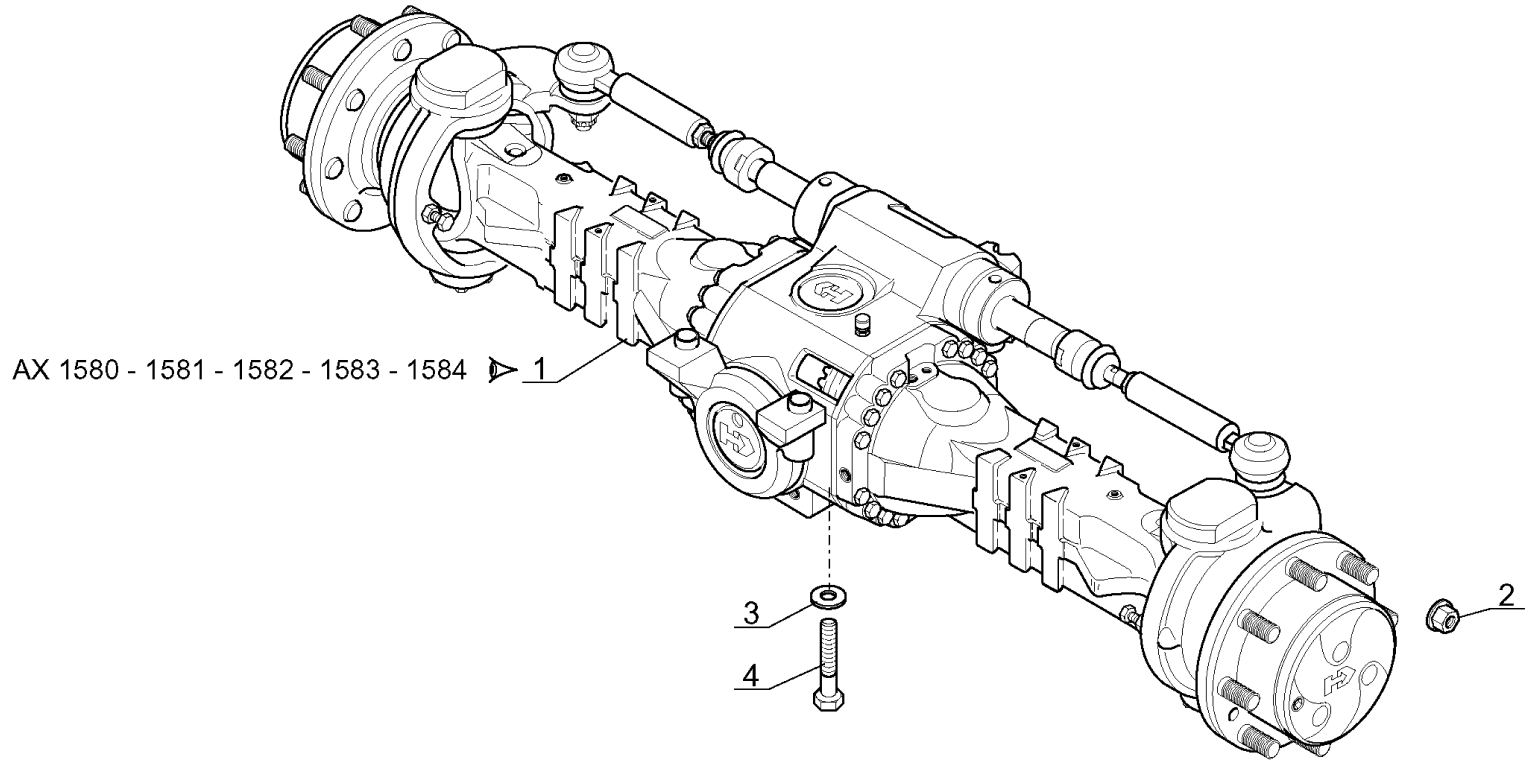

1	STEER AXLE ASSEMBLY, 4WD, TORQUE CONVERTER MODELS		QUANTITY / MODEL									AX 2551							
			M30-4T	M40-4T	M50-4T							M30-4T L	M40-4T L	M50-4T L					
ITEM	PART NO.	DESCRIPTION																	
1	247289	Steer axle, DANA 212/492, 4WD (Torque Converter MODELS)	1	1	1									1	1	1			
2	247292	Wheel nut	16	16	16									16	16	16			
3	42349	Washer	4	4	4									4	4	4			
4	58633	Screw	4	4	4									4	4	4			

104.00

AX 1580
TIER III

STEER AXLE CASING, 4WD TORQUE CONVERTER MODELS

M30-4T
M40-4T
M50-4T

M30-4T L
M40-4T L
M50-4T L

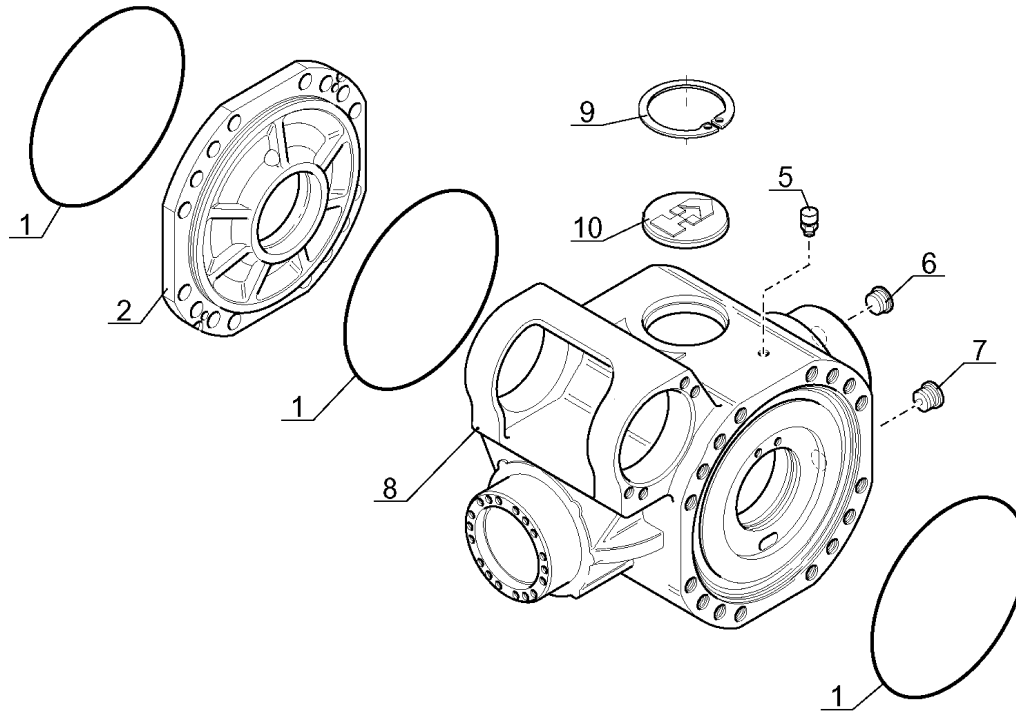

1	STEER AXLE CASING, 4WD TORQUE CONVERTER MODELS		QUANTITY / MODEL									AX 1580						
			M30-4T	M40-4T	M50-4T							M30-4T L	M40-4T L	M50-4T L				
ITEM	PART NO.	DESCRIPTION																
1	106533	O-ring	3	3	3							3	3	3				
2	562531	Housing	1	1	1							1	1	1				
5	562470	Air breather	1	1	1							1	1	1				
6	603638	Plug	1	1	1							1	1	1				
7	702418	Plug, magnetic	1	1	1							1	1	1				
8	706031	Central casing	1	1	1							1	1	1				
9	133044	Circlip	1	1	1							1	1	1				
10	602293	Plug	1	1	1							1	1	1				

105.00

AX 1581
TIER III

STEER AXLE DIFFERENTIAL, 4WD TORQUE CONVERTER MODELS

M30-4T
M40-4T
M50-4T

M30-4T L
M40-4T L
M50-4T L

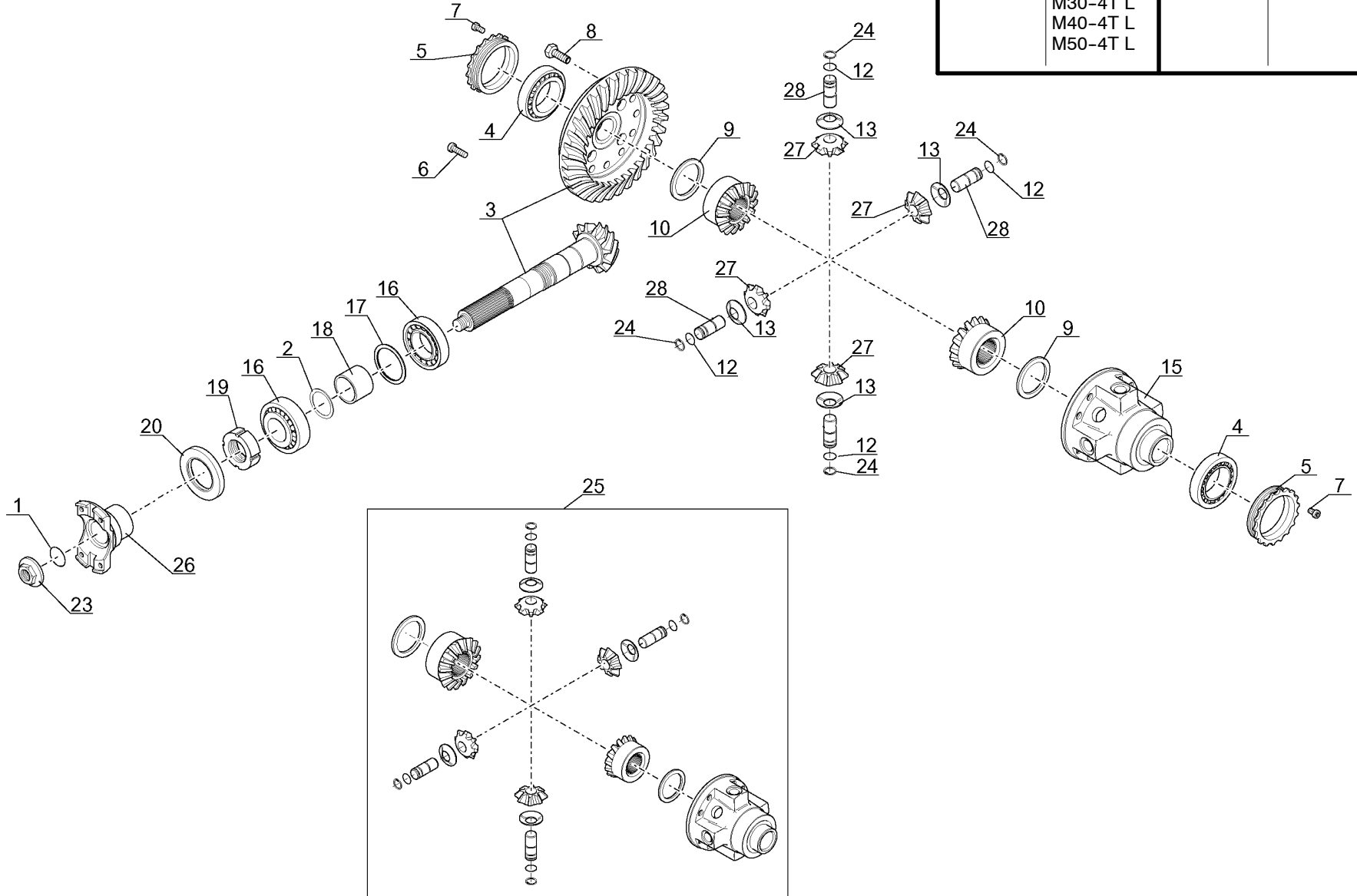

			QUANTITY / MODEL									AX 1581					
1 STEER AXLE DIFFERENTIAL, 4WD TORQUE CONVERTER MODELS			M30-4T	M40-4T	M50-4T						M30-4T L	M40-4T L	M50-4T L				
ITEM	PART NO.	DESCRIPTION															
1	562472	O-ring	1	1	1						1	1	1				
2	550556	Shim .15mm (.006 in)	A/R	A/R	A/R						A/R	A/R	A/R				
2	550557	Shim .20mm (.008 in)	A/R	A/R	A/R						A/R	A/R	A/R				
2	551616	Shim .40mm (.016 in)	A/R	A/R	A/R						A/R	A/R	A/R				
2	552517	Shim .50mm (.020 in)	A/R	A/R	A/R						A/R	A/R	A/R				
3	603648	Bevel drive gear	1	1	1						1	1	1				
4	106550	Bearing	2	2	2						2	2	2				
5	562474	Nut	2	2	2						2	2	2				
6	133186	Screw	4	4	4						4	4	4				
7	109912	Screw	2	2	2						2	2	2				
8	601243	Screw	12	12	12						12	12	12				
9	562476	Washer	2	2	2						2	2	2				
10	562477	Planetary	2	2	2						2	2	2				
12	562479	Circlips	4	4	4						4	4	4				
13	562480	Washer	4	4	4						4	4	4				
15	562482	Differential housing	1	1	1						1	1	1				
16	133069	Bearing	2	2	2						2	2	2				
17	474298	Shim .20mm (.008 in)	A/R	A/R	A/R						A/R	A/R	A/R				
17	474300	Shim .30mm (.012 in)	A/R	A/R	A/R						A/R	A/R	A/R				
17	551615	Shim .15mm (.006 in)	A/R	A/R	A/R						A/R	A/R	A/R				
17	552516	Shim .10mm (.004 in)	A/R	A/R	A/R						A/R	A/R	A/R				
18	562483	Spacer	1	1	1						1	1	1				
19	133570	Nut	1	1	1						1	1	1				
20	107293	Seal	1	1	1						1	1	1				

		QUANTITY / MODEL											AX 1581																								
		M30-4T	M40-4T	M50-4T							M30-4T L	M40-4T L	M50-4T L																								
2	STEER AXLE DIFFERENTIAL, 4WD TORQUE CONVERTER MODELS																																				
ITEM	PART NO.	DESCRIPTION																																			
23	562485	Nut															1	1	1								1	1	1								
24	562486	Circlips															4	4	4										4	4	4						
25	600552	Rear axle differential															1	1	1										1	1	1						
26	704684	Flange															1	1	1										1	1	1						
27	705645	Planet wheel															4	4	4												4	4	4				
28	705646	Pin															4	4	4												4	4	4				

AX 1582
TIER III

**STEER AXLE REDUCTION GEAR,
4WD TORQUE CONVERTER MODELS**

M30-4T
M40-4T
M50-4T

M30-4T L
M40-4T L
M50-4T L

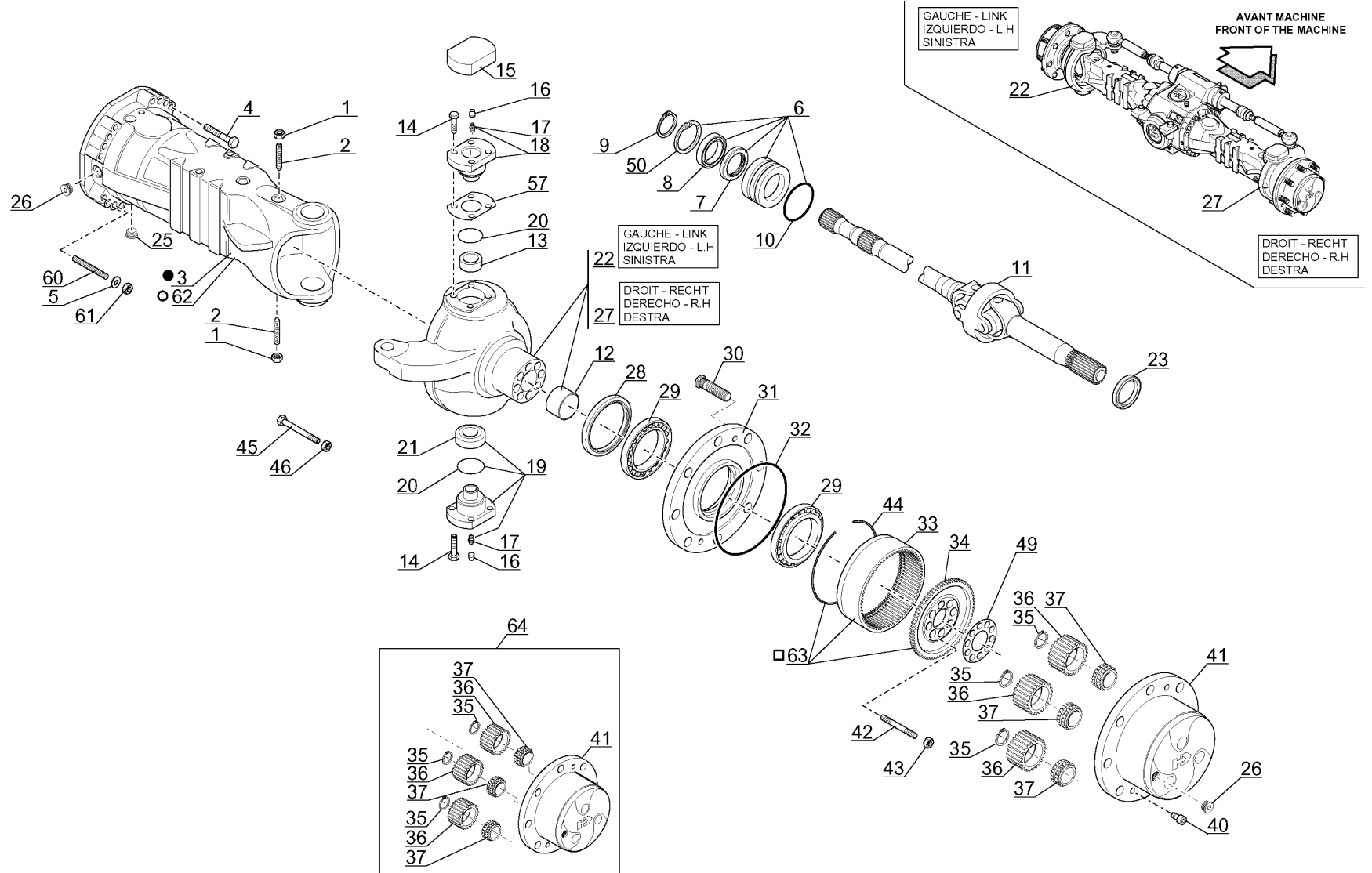

1	STEER AXLE REDUCTION GEAR, 4WD TORQUE CONVERTER MODELS		QUANTITY / MODEL									AX 1582						
			M30-4T	M40-4T	M50-4T							M30-4T L	M40-4T L	M50-4T L				
ITEM	PART NO.	DESCRIPTION																
1	133090	Nut	2	2	2							2	2	2				
2	562750	Screw	2	2	2							2	2	2				
4	702138	Bolt (STEER AXLE 801988)	28	28	28							28	28	28				
5	562490	Washer	4	4	4							4	4	4				
6	563903	Flange	2	2	2							2	2	2				
7	108100	Seal	2	2	2							2	2	2				
8	105101	Bearing	2	2	2							2	2	2				
9	105424	Circlips	2	2	2							2	2	2				
10	562752	O-ring	2	2	2							2	2	2				
11	603650	Axle, Cardan	2	2	2							2	2	2				
12	477847	Bushing	2	2	2							2	2	2				
13	603651	Bushing	2	2	2							2	2	2				
14	562475	Screw	20	20	20							20	20	20				
15	600559	Cover	2	2	2							2	2	2				
16	107796	Plug	4	4	4							4	4	4				
17	133103	Greaser	4	4	4							4	4	4				
18	564903	Pivot pin	2	2	2							2	2	2				
19	564898	Pivot pin	2	2	2							2	2	2				
20	562499	Seal	4	4	4							4	4	4				
21	562500	Bushing	2	2	2							2	2	2				
22	604256	LH steering case	1	1	1							1	1	1				
23	603653	Seal	2	2	2							2	2	2				
25	702418	Magnetic plug	2	2	2							2	2	2				
26	603638	Plug	4	4	4							4	4	4				
27	604257	RH steering case	1	1	1							1	1	1				

2	STEER AXLE REDUCTION GEAR, 4WD TORQUE CONVERTER MODELS		QUANTITY / MODEL									AX 1582						
			M30-4T	M40-4T	M50-4T							M30-4T L	M40-4T L	M50-4T L				
ITEM	PART NO.	DESCRIPTION																
28	604656	Seal	2	2	2							2	2	2				
29	562504	Bearing	4	4	4							4	4	4				
30	702778	Wheel stud	16	16	16							16	16	16				
31	601246	Wheel hub	2	2	2							2	2	2				
32	106533	O-ring	2	2	2							2	2	2				
33	564133	Gear ring	2	2	2							2	2	2				
34	565998	Ring gear bracket	2	2	2							2	2	2				
35	562508	Circlips	6	6	6							6	6	6				
36	562509	Planet wheel	6	6	6							6	6	6				
37	562510	Bearing	6	6	6							6	6	6				
40	600670	Screw	4	4	4							4	4	4				
41	604252	Planet gear carrier	2	2	2							2	2	2				
42	562512	Stud, bolt	16	16	16							16	16	16				
43	562513	Nut	16	16	16							16	16	16				
44	562514	Circlips	2	2	2							2	2	2				
45	602219	Adjusting screw	4	4	4							4	4	4				
46	474313	Nut	4	4	4							4	4	4				
49	562515	Locking plate	2	2	2							2	2	2				
50	133044	Circlips	2	2	2							2	2	2				
57	564679	Shim .15mm (.006 in)	A/R	A/R	A/R							A/R	A/R	A/R				
57	564680	Shim .20mm (.008 in)	A/R	A/R	A/R							A/R	A/R	A/R				
57	564681	Shim .50mm (.020 in)	A/R	A/R	A/R							A/R	A/R	A/R				
60	603655	Stud, bolt	4	4	4							4	4	4				
61	602275	Nut	4	4	4							4	4	4				
62	706961	Lateral axle case	2	2	2							2	2	2				
63	706355	Ring gear bracket	1	1	1							1	1	1				
64	706962	Planet wheel bracket kit	1	1	1							1	1	1				

AX 1583
TIER III

STEERING CYLINDER, 4WD TORQUE CONVERTER MODELS

M30-4T
M40-4T
M50-4T

M30-4T L
M40-4T L
M50-4T L

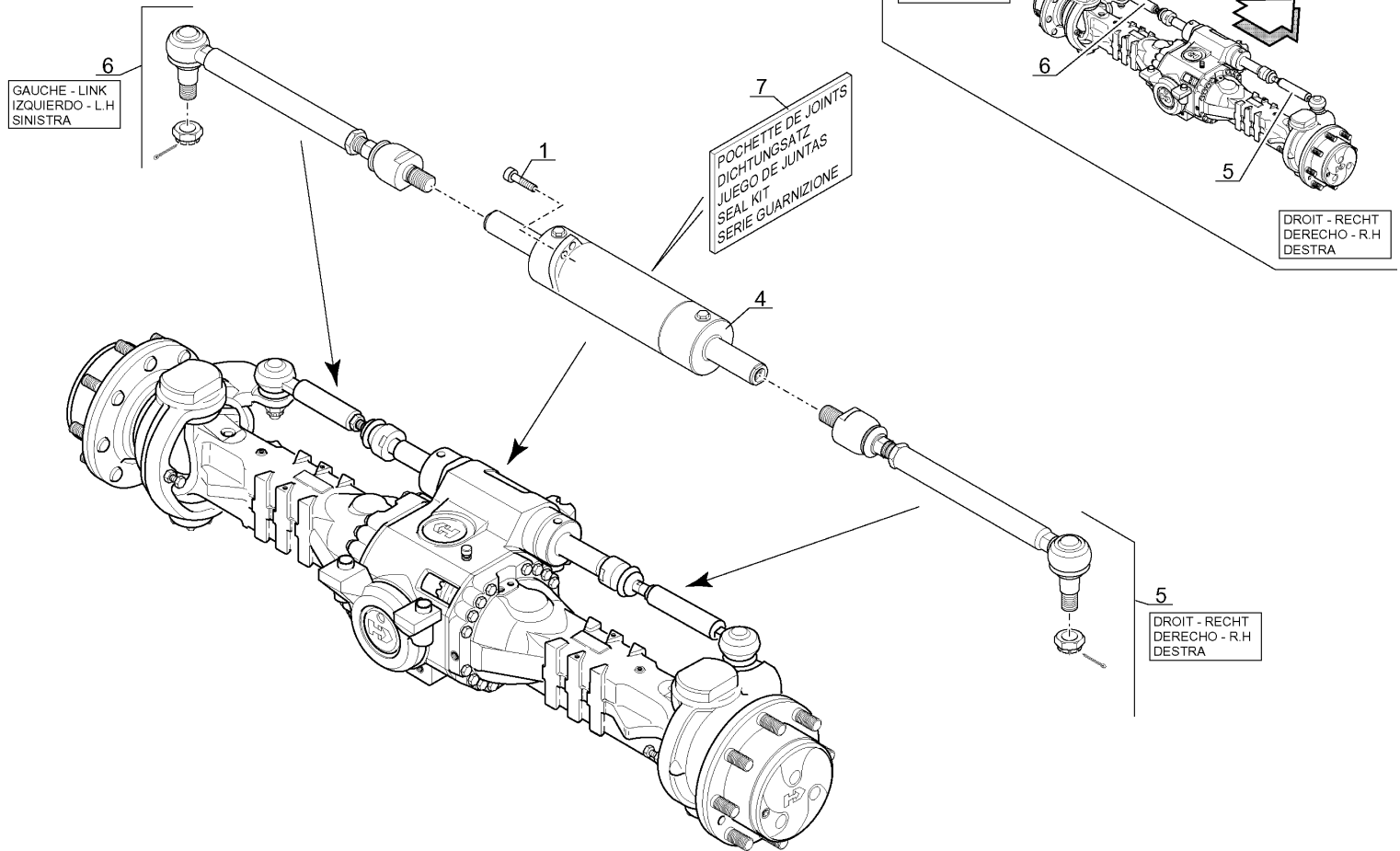

1	STEERING CYLINDER, 4WD TORQUE CONVERTER MODELS		QUANTITY / MODEL									AX 1583					
			M30-4T	M40-4T	M50-4T							M30-4T L	M40-4T L	M50-4T L			
ITEM	PART NO.	DESCRIPTION															
1	562526	Screw	4	4	4							4	4	4			
4	702067	Steering cylinder (STEER AXLE 801988)	1	1	1							1	1	1			
5	603657	Linked tie rod	1	1	1							1	1	1			
6	603657	Linked tie rod	1	1	1							1	1	1			
7	702147	Seal kit (STEER AXLE 801988)	1	1	1							1	1	1			

108.00

AX 1584
TIER III

STEER AXLE SUPPORT BRACKET, 4WD,
HYDRASTATIC AND TORQUE CONVERTER MODELS

M30-4T
M40-4T
M50-4T

M30-4T H
M40-4T H
M50-4T H

M30-4T L
M40-4T L
M50-4T L

M30-4T H L
M40-4T H L
M50-4T H L

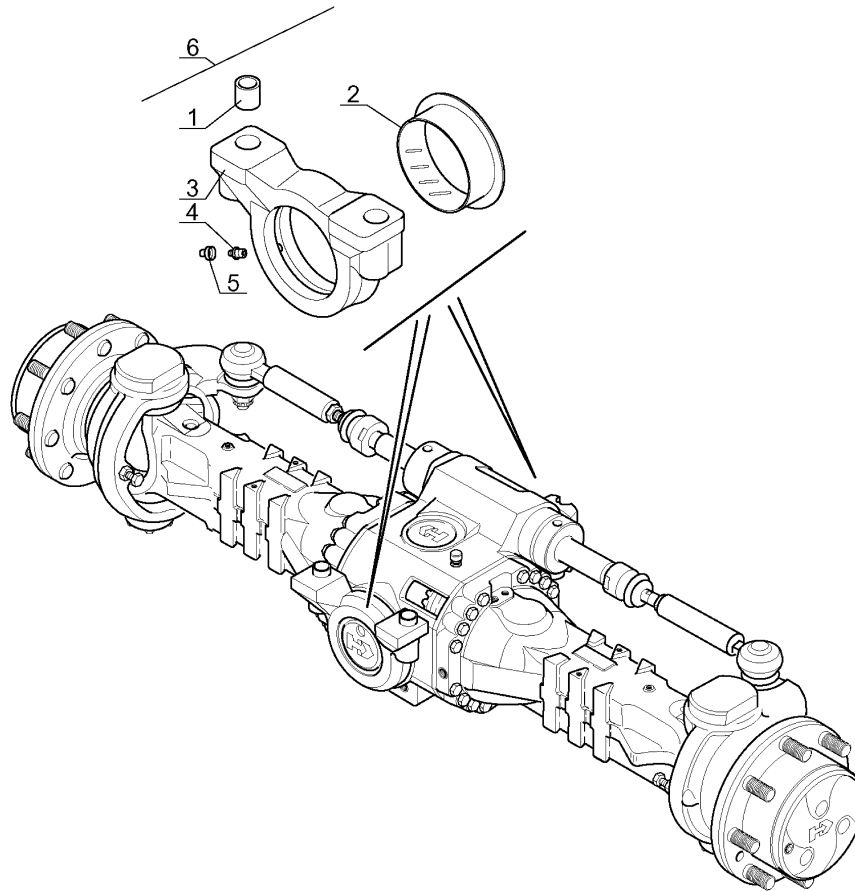

1	STEER AXLE SUPPORT BRACKET, 4WD, HYDRASTATIC AND TORQUE CONVERTER MODELS		QUANTITY / MODEL									AX 1584					
			M30-4T	M40-4T	M50-4T		M30-4T H	M40-4T H	M50-4T H		M30-4T L	M40-4T L	M50-4T L		M30-4T HL	M40-4T HL	M50-4T HL
ITEM	PART NO.	DESCRIPTION															
1	477964	Coupling	4	4	4	4	4	4	4	4	4	4	4	4	4	4	4
2	477538	Bushing	2	2	2	2	2	2	2	2	2	2	2	2	2	2	2
3	564693	Axle bracket	2	2	2	2	2	2	2	2	2	2	2	2	2	2	2
4	133103	Greaser	2	2	2	2	2	2	2	2	2	2	2	2	2	2	2
5	107796	Plug	2	2	2	2	2	2	2	2	2	2	2	2	2	2	2
6	601561	Axle bracket	2	2	2	2	2	2	2	2	2	2	2	2	2	2	2

109.00

AX 1854
TIER III

STEER AXLE ASSEMBLY, 4WD, HYDRASTATIC MODELS

M30-4T H
M40-4T H
M50-4T H

M30-4T H L
M40-4T H L
M50-4T H L

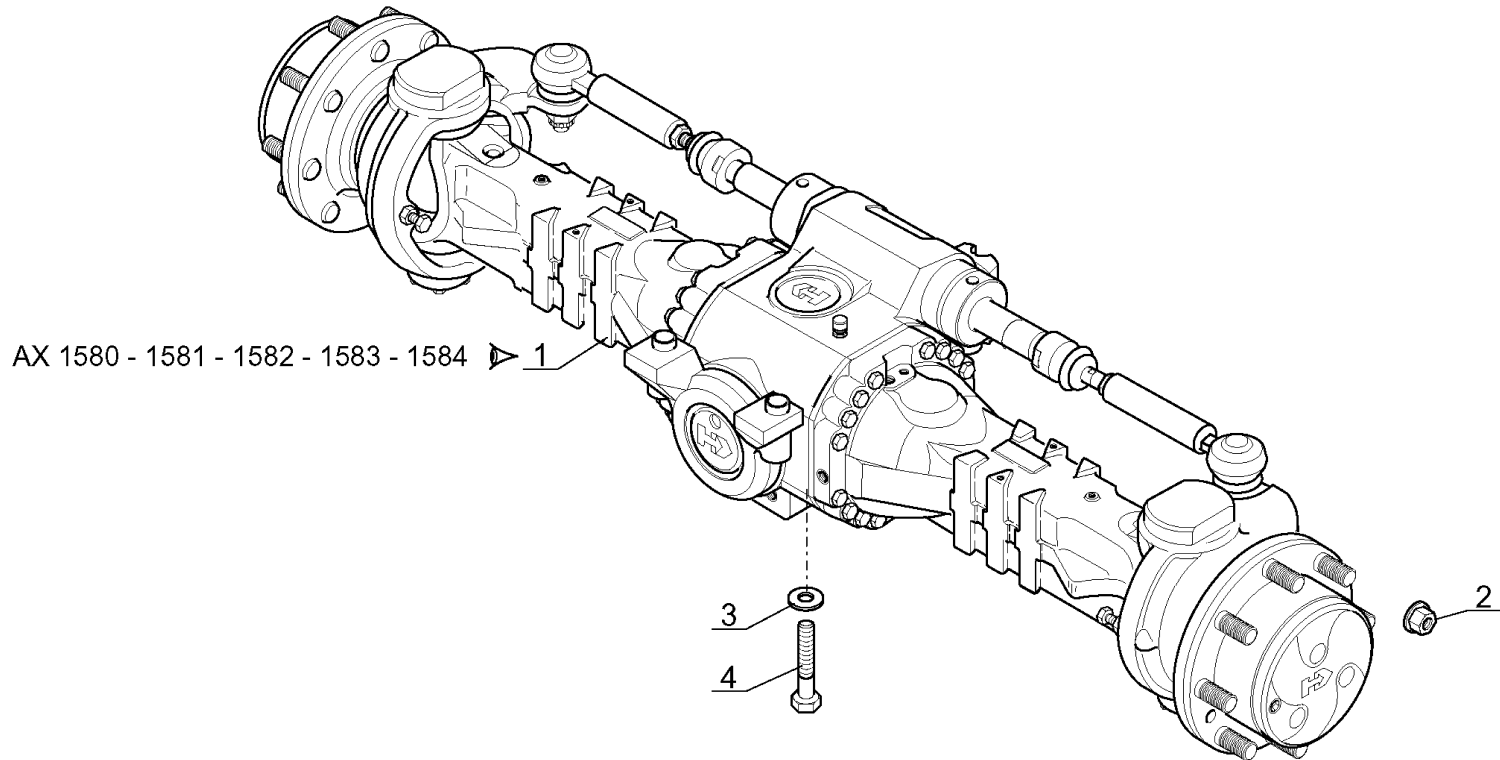

1	STEER AXLE ASSEMBLY, 4WD, HYDRASTATIC MODELS		QUANTITY / MODEL										AX 1854													
															M30-4T H	M40-4T H	M50-4T H				M30-4T HL	M40-4T HL	M50-4T HL			
ITEM	PART NO.	DESCRIPTION																								
1	804064	Steer axle, DANA 212/496, 4WD (Hydrastatic Models)																								
2	247292	Wheel nut																								
3	61683	Washer																								
4	58633	Screw																								

110.00

BC 108
TIER III

HYDROSTATIC MOTOR

M30-2T H	M30-4T H
M40-2T H	M40-4T H
M50-2T H	M50-4T H

M30-2T H L	M30-4T H L
M40-2T H L	M40-4T H L
M50-2T H L	M50-4T H L

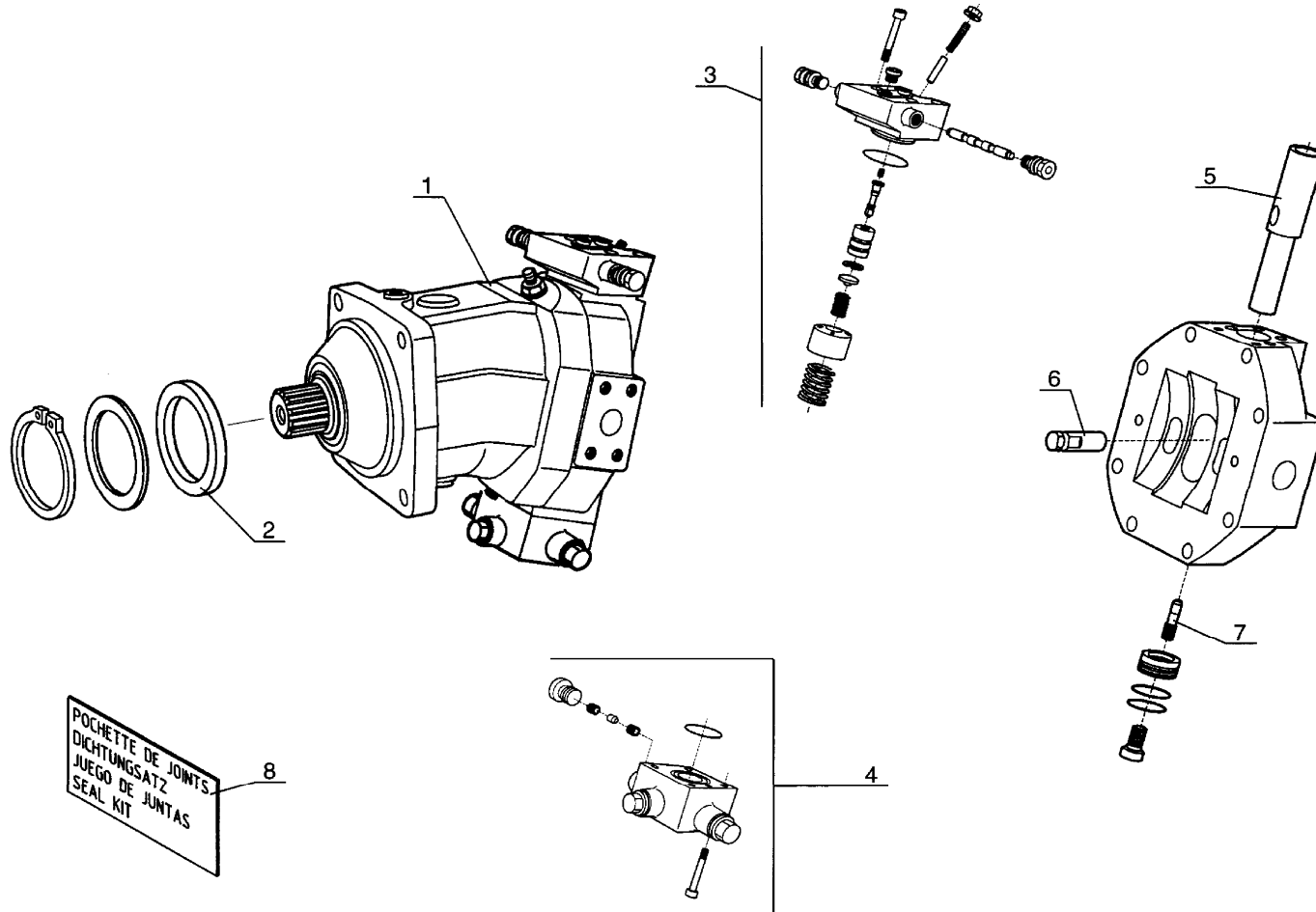

1	HYDROSTATIC MOTOR		QUANTITY / MODEL								BC 108				
ITEM	PART NO.	DESCRIPTION	M30-2T H	M40-2T H	M50-2T H							M30-4T HL	M40-4T HL	M50-4T HL	
1	208701	Hydrostatic motor assembly	1	1	1	1						1	1	1	1
2	561198	Seal	1	1	1	1						1	1	1	1
3	561187	Control parts	1	1	1	1						1	1	1	1
4	552608	Flushing and boost pressure valve	1	1	1	1						1	1	1	1
5	562317	Piston	1	1	1	1						1	1	1	1
6	562318	Swivel pin	1	1	1	1						1	1	1	1
7	562319	Screw	1	1	1	1						1	1	1	1
8	562320	Seal kit	1	1	1	1						1	1	1	1

111.00

BC 154
TIER III

TRANSMISSION, HYDROSTATIC PUMP

M30-2T H	M30-4T H
M40-2T H	M40-4T H
M50-2T H	M50-4T H

M30-2T H L	M30-4T H L
M40-2T H L	M40-4T H L
M50-2T H L	M50-4T H L

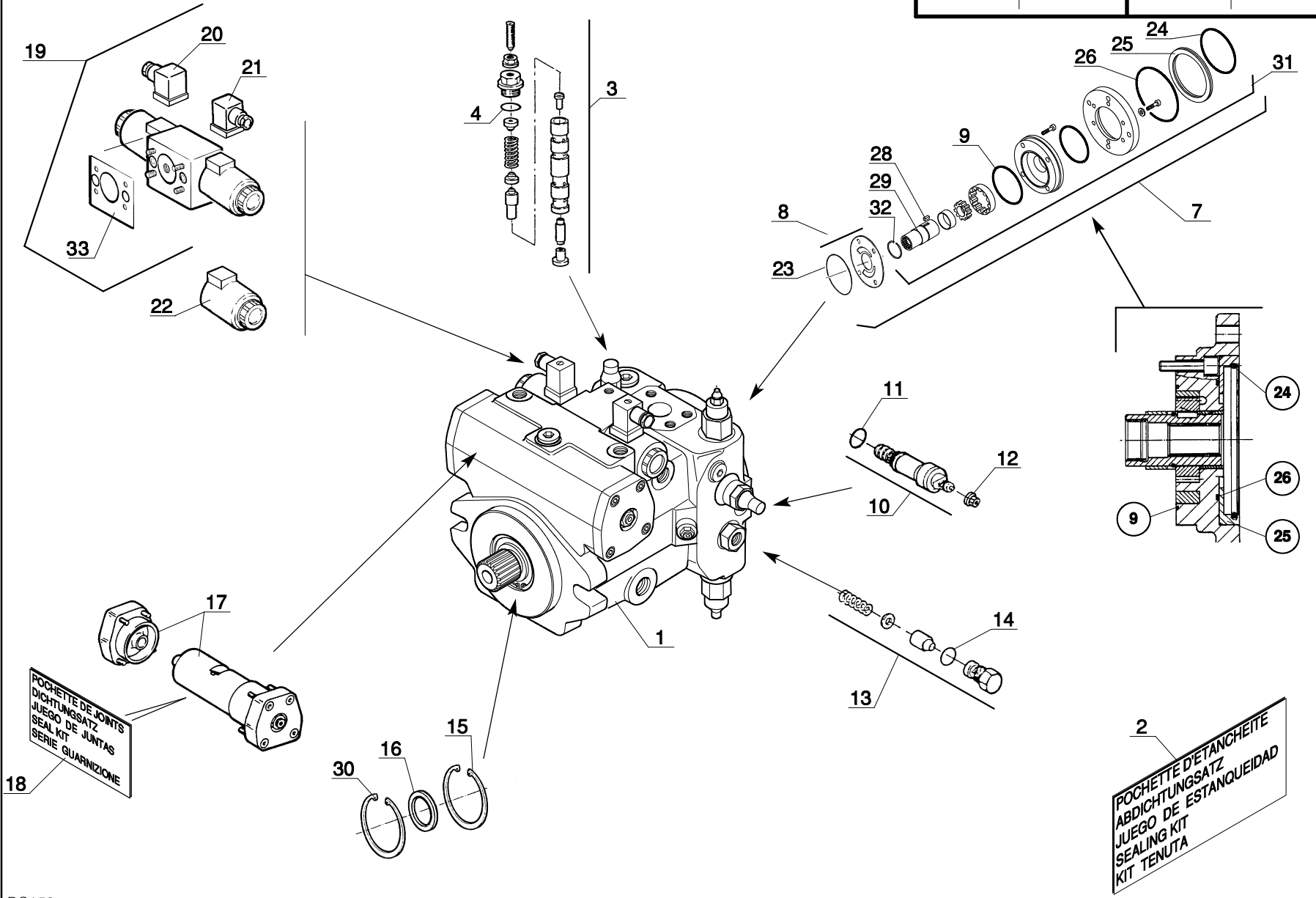

1	TRANSMISSION, HYDROSTATIC PUMP		QUANTITY / MODEL								BC 154				
											M30-4T H	M40-4T H	M50-4T H		M30-4T HL
ITEM	PART NO.	DESCRIPTION	M30-2T H	M40-2T H	M50-2T H					M30-2T HL	M40-2T HL	M50-2T HL			
1	807801	Hydrostatic pump, complete	1	1	1	1				1	1	1	1		
2	603534	Seal kit	1	1	1	1				1	1	1	1		
3	552629	Valve	1	1	1	1				1	1	1	1		
4	201149	O-ring	1	1	1	1				1	1	1	1		
5															
6															
7	602061	Boost pump	1	1	1	1				1	1	1	1		
8	601589	Friction lining	1	1	1	1				1	1	1	1		
9	201198	Seal	1	1	1	1				1	1	1	1		
10	458502	Control valve	1	1	1	1				1	1	1	1		
11	401831	O-ring	1	1	1	1				1	1	1	1		
12	409248	Nut	1	1	1	1				1	1	1	1		
13	601590	Relief valve	1	1	1	1				1	1	1	1		
14	601594	O-ring	1	1	1	1				1	1	1	1		
15	552634	Circlips	1	1	1	1				1	1	1	1		
16	602062	Seal	1	1	1	1				1	1	1	1		
17	601593	Positioning piston	1	1	1	1				1	1	1	1		
18	601597	Seal kit	1	1	1	1				1	1	1	1		
19	602063	Valve bank	1	1	1	1				1	1	1	1		
20	58112	Connection test	1	1	1	1				1	1	1	1		
21	58113	Connection test	1	1	1	1				1	1	1	1		
22	602064	Solenoid	2	2	2	2				2	2	2	2		
23	201198	Seal	1	1	1	1				1	1	1	1		
24	474783	O-ring	1	1	1	1				1	1	1	1		
25	552622	Bushing	1	1	1	1				1	1	1	1		
26	201199	O-ring	1	1	1	1				1	1	1	1		
28	600525	Key	1	1	1	1				1	1	1	1		

112.00

2	TRANSMISSION, HYDROSTATIC PUMP		QUANTITY / MODEL								BC 154				
ITEM	PART NO.	DESCRIPTION	M30-2T H	M40-2T H	M50-2T H							M30-4T HL	M40-4T HL	M50-4T HL	
29	602065	Coupling	1	1	1	1						1	1	1	1
30	601592	Circlips	1	1	1	1						1	1	1	1
31	200944	Boost pump	1	1	1	1						1	1	1	1
32	201197	Snap ring	1	1	1	1						1	1	1	1
33	552504	Gasket	1	1	1	1						1	1	1	1

BP 177
TIER III

TRANSMISSION, 4-SPEED, 2WD
TRANSMISSION REF: 222572 TYPE: 15984

M30-2T			
M40-2T			
M50-2T			
M30-2T L			
M40-2T L			
M50-2T L			

SEE **4AA606** FOR DIPSTICK ASSEMBLY

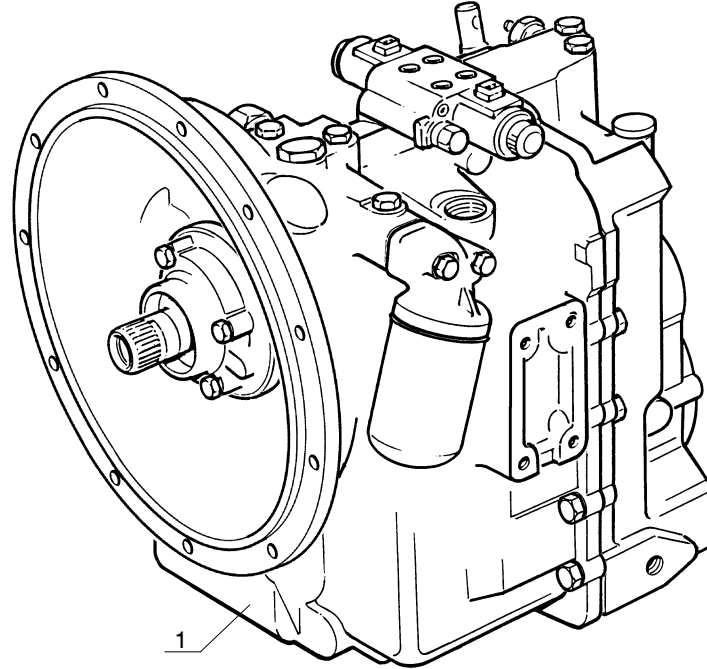

			QUANTITY / MODEL											BP 177					
1			TRANSMISSION, 4-SPEED, 2WD																
ITEM	PART NO.	DESCRIPTION	M30-2T	M40-2T	M50-2T							M30-2T L	M40-2T L	M50-2T L					
1	222572	Gear box, complete	1	1	1	1						1	1	1	1				

113.00

BP 178
TIER III

TRANSMISSION, 4-SPEED, 2WD, EXTERNAL COMPONENTS
TRANSMISSION REF: 222572 TYPE: 15984

M30-2T
M40-2T
M50-2T

M30-2T L
M40-2T L
M50-2T L

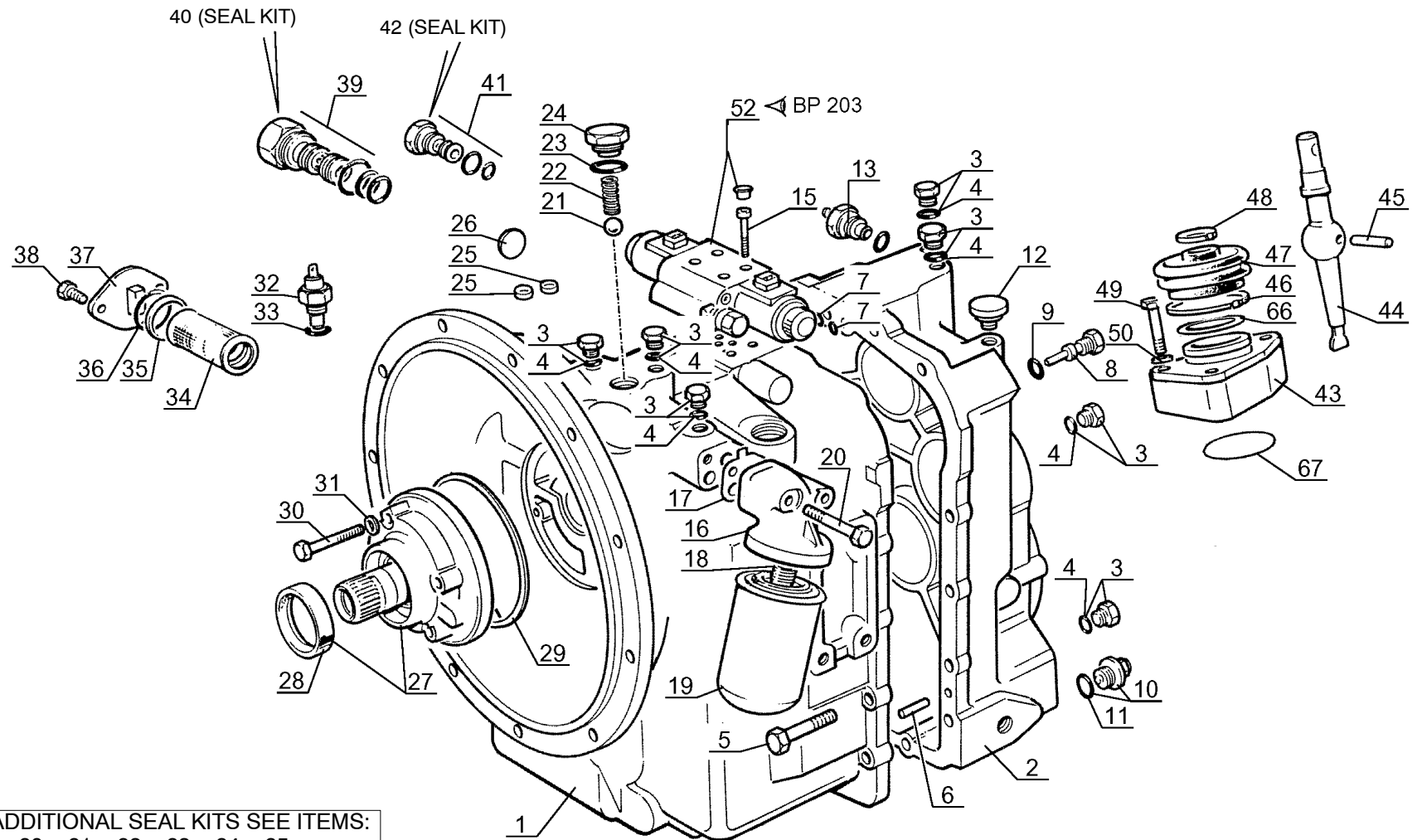

FOR ADDITIONAL SEAL KITS SEE ITEMS:
60 - 61 - 62 - 63 - 64 - 65
ON THE FOLLOWING PAGES

1	TRANSMISSION, 4-SPEED, 2WD, EXTERNAL COMPONENTS		QUANTITY / MODEL											BP 178					
			M30-4T	M40-4T	M50-4T						M30-4T L	M40-4T L	M50-4T L						
ITEM	PART NO.	DESCRIPTION	M30-2T	M40-2T	M50-2T							M30-2T L	M40-2T L	M50-2T L					
1	561840	Transmission housing	1	1	1	1						1	1	1	1				
2	561841	Transmission rear case	1	1	1	1						1	1	1	1				
3	550705	Plug	13	13	13	13						13	13	13	13				
4	109657	O-ring	13	13	13	13						13	13	13	13				
5	109727	Screw	16	16	16	16						16	16	16	16				
6	109703	Stud bolt	2	2	2	2						2	2	2	2				
7	561833	O-ring	3	3	3	3						3	3	3	3				
8	561835	Plug	1	1	1	1						1	1	1	1				
9	109657	O-ring	1	1	1	1						1	1	1	1				
10	473366	Drain plug	1	1	1	1						1	1	1	1				
11	473915	O-ring	1	1	1	1						1	1	1	1				
12	109705	Air breather	1	1	1	1						1	1	1	1				
13	705009	Oil pressure switch	1	1	1	1						1	1	1	1				
15	561829	Screw	4	4	4	4						4	4	4	4				
16	561837	Filter housing	1	1	1	1						1	1	1	1				
17	109646	Gasket	1	1	1	1						1	1	1	1				
18	109658	Connection	1	1	1	1						1	1	1	1				
19	561749	Oil filter	1	1	1	1						1	1	1	1				
20	109728	Screw	2	2	2	2						2	2	2	2				
21	561836	Ball	1	1	1	1						1	1	1	1				
22	561765	Spring	1	1	1	1						1	1	1	1				
23	561827	O-ring	1	1	1	1						1	1	1	1				
24	561828	Plug	1	1	1	1						1	1	1	1				
25	561822	Plug	2	2	2	2						2	2	2	2				
26	561834	Plug	1	1	1	1						1	1	1	1				
27	561930	Pump, complete	1	1	1	1						1	1	1	1				
28	109690	Seal	1	1	1	1						1	1	1	1				
29	109676	O-ring	1	1	1	1						1	1	1	1				
30	561760	Screw	4	4	4	4						4	4	4	4				
31	109659	Washer	4	4	4	4						4	4	4	4				

114.00

2	TRANSMISSION, 4-SPEED, 2WD, EXTERNAL COMPONENTS		QUANTITY / MODEL											BP 178				
			M30-4T	M40-4T	M50-4T						M30-4T L	M40-4T L	M50-4T L					
			M30-2T	M40-2T	M50-2T						M30-2T L	M40-2T L	M50-2T L					
ITEM	PART NO.	DESCRIPTION																
32	702388	Oil temp sensor	1	1	1	1							1	1	1	1		
33	109657	O-ring	1	1	1	1							1	1	1	1		
34	109565	Suction strainer	1	1	1	1							1	1	1	1		
35	550626	Washer	1	1	1	1							1	1	1	1		
36	550627	O-ring	1	1	1	1							1	1	1	1		
37	473368	Cover	1	1	1	1							1	1	1	1		
38	109732	Screw	2	2	2	2							2	2	2	2		
39	561830	Pressure regulation valve	1	1	1	1							1	1	1	1		
40	561946	Seal kit	1	1	1	1							1	1	1	1		
41	561823	Over pressure valve	1	1	1	1							1	1	1	1		
42	561945	Seal kit	1	1	1	1							1	1	1	1		
43	562040	Upper seat	1	1	1	1							1	1	1	1		
44	561816	Gear lever foot	1	1	1	1							1	1	1	1		
45	109681	Pin	1	1	1	1							1	1	1	1		
46	561820	Clamp	1	1	1	1							1	1	1	1		
47	109612	Dust cover	1	1	1	1							1	1	1	1		
48	561821	Clamp	1	1	1	1							1	1	1	1		
49	561760	Screw	3	3	3	3							3	3	3	3		
50	561761	Washer	3	3	3	3							3	3	3	3		
52	702639	Electrical control valve	1	1	1	1							1	1	1	1		
60	561931	Pump kit	A/R	A/R	A/R	A/R							A/R	A/R	A/R	A/R		
61	561934	Small parts kit	A/R	A/R	A/R	A/R							A/R	A/R	A/R	A/R		
62	562002	Seal kit	A/R	A/R	A/R	A/R							A/R	A/R	A/R	A/R		
63	562003	Seal kit	A/R	A/R	A/R	A/R							A/R	A/R	A/R	A/R		
64	562006	Valve kit	A/R	A/R	A/R	A/R							A/R	A/R	A/R	A/R		
65	561942	Complete repair kit	A/R	A/R	A/R	A/R							A/R	A/R	A/R	A/R		
66	600365	Gasket	1	1	1	1							1	1	1	1		
67	600366	O-ring	1	1	1	1							1	1	1	1		

BP 76
TIER III

TRANSMISSION, 4-SPEED, 2WD, INTERNAL COMPONENTS
TRANSMISSION REF: 222572 TYPE: 15984

M30-2T
M40-2T
M50-2T

M30-2T L
M40-2T L
M50-2T L

KIT COMPLET, VOIR NOMENCLATURE
KOMPLETTER KIT, SIEHE STÜCKLISTE
JUEGO COMPLETO, VER NOMENCLATURA
COMPLETE KIT, SEE NOMENCLATURE
KIT COMPLETO, VEDERE NOMENCLATURA

Rep - Hinw - Fig - Item - Sequenza
70 71 - 72 - 73 - 74 - 75 - 76
77 - 78 79 83 84

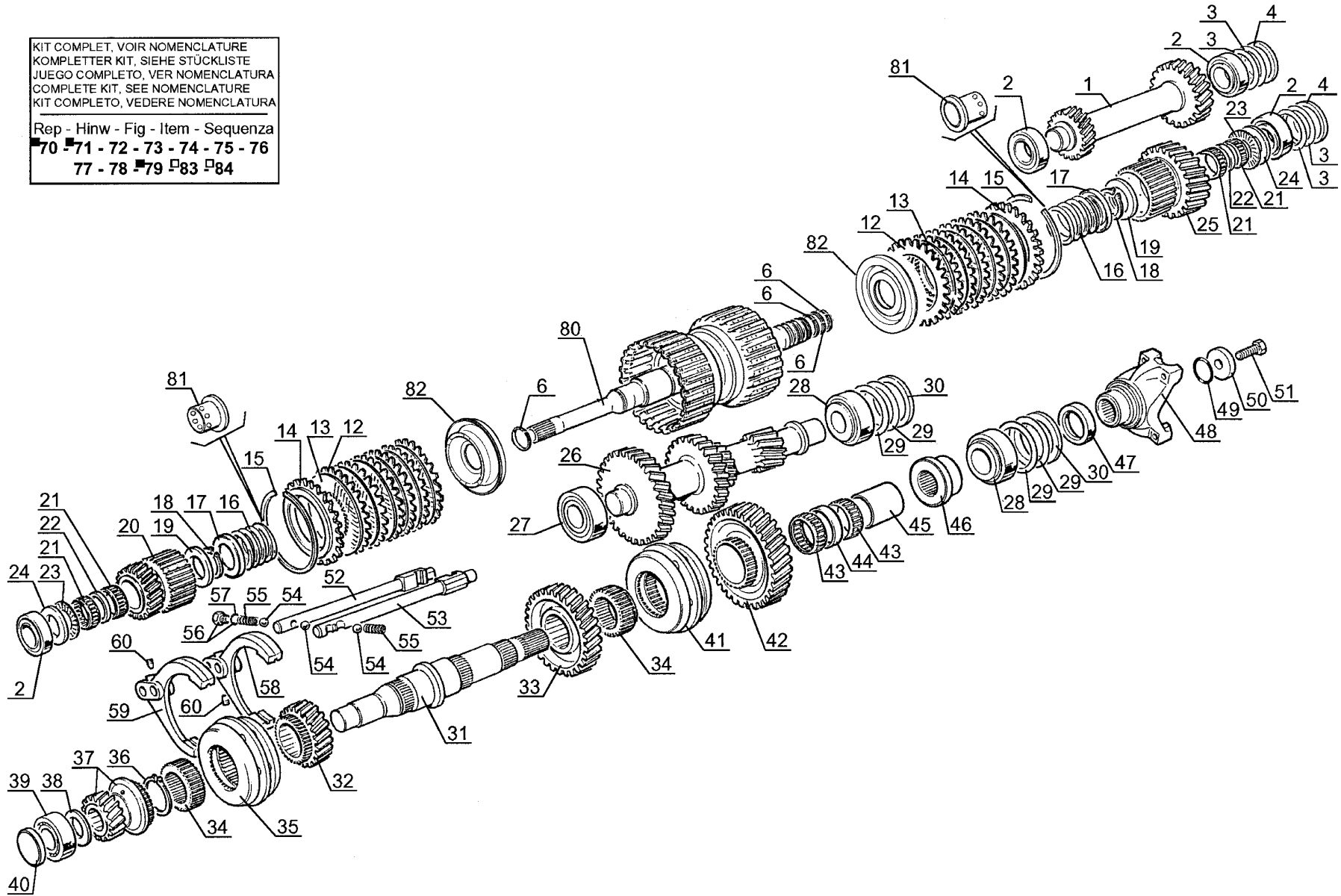

1	TRANSMISSION, 4-SPEED, 2WD, INTERNAL COMPONENTS		QUANTITY / MODEL												BP 76					
			M30-2T	M40-2T	M50-2T								M30-2T L	M40-2T L	M50-2T L					
ITEM	PART NO.	DESCRIPTION	M30-2T	M40-2T	M50-2T								M30-2T L	M40-2T L	M50-2T L					
1	561791	Reverse idler gear	1	1	1	1							1	1	1	1				
2	109701	Bearing	4	4	4	4							4	4	4	4				
3	109615	Shim .051mm (.002 in)	A/R	A/R	A/R	A/R							A/R	A/R	A/R	A/R				
3	109616	Shim .076mm (.003 in)	A/R	A/R	A/R	A/R							A/R	A/R	A/R	A/R				
3	109617	Shim .127mm (.005 in)	A/R	A/R	A/R	A/R							A/R	A/R	A/R	A/R				
3	109618	Shim .178mm (.007 in)	A/R	A/R	A/R	A/R							A/R	A/R	A/R	A/R				
3	109619	Shim .381mm (.015 in)	A/R	A/R	A/R	A/R							A/R	A/R	A/R	A/R				
3	109620	Shim .508mm (.020 in)	A/R	A/R	A/R	A/R							A/R	A/R	A/R	A/R				
4	109597	Spacer	2	2	2	2							2	2	2	2				
6	109624	Seal	4	4	4	4							4	4	4	4				
12	561797	Clutch disc	12	12	12	12							12	12	12	12				
13	561798	Friction disc	12	12	12	12							12	12	12	12				
14	561796	Plate	2	2	2	2							2	2	2	2				
15	561795	Circlips	2	2	2	2							2	2	2	2				
16	561801	Spring	2	2	2	2							2	2	2	2				
17	561800	Bushing	2	2	2	2							2	2	2	2				
18	561799	Circlips	2	2	2	2							2	2	2	2				
19	561789	Thrust washer	2	2	2	2							2	2	2	2				
20	561793	Forward primary gear	1	1	1	1							1	1	1	1				
21	109651	Roller bearing	4	4	4	4							4	4	4	4				
22	561809	Spacer	2	2	2	2							2	2	2	2				
23	561762	Bearing	2	2	2	2							2	2	2	2				
24	561764	Stop washer	2	2	2	2							2	2	2	2				
25	561794	Backward primary gear	1	1	1	1							1	1	1	1				
26	561790	Countershaft	1	1	1	1							1	1	1	1				
27	109622	Bearing	1	1	1	1							1	1	1	1				
28	561786	Bearing	2	2	2	2							2	2	2	2				

115.00

2	TRANSMISSION, 4-SPEED, 2WD, INTERNAL COMPONENTS		QUANTITY / MODEL												BP 76					
			M30-2T	M40-2T	M50-2T							M30-2T L	M40-2T L	M50-2T L						
ITEM	PART NO.	DESCRIPTION	M30-2T	M40-2T	M50-2T								M30-2T L	M40-2T L	M50-2T L					
29	109599	Shim .051mm (.002 in)	A/R	A/R	A/R	A/R							A/R	A/R	A/R	A/R				
29	109600	Shim .076mm (.003 in)	A/R	A/R	A/R	A/R							A/R	A/R	A/R	A/R				
29	109601	Shim .178mm (.007 in)	A/R	A/R	A/R	A/R							A/R	A/R	A/R	A/R				
29	109602	Shim .559mm (.022 in)	A/R	A/R	A/R	A/R							A/R	A/R	A/R	A/R				
30	109598	Spacer	2	2	2	2							2	2	2	2				
31	561785	Output shaft	1	1	1	1							1	1	1	1				
32	561775	3rd gear	1	1	1	1							1	1	1	1				
33	561776	2nd gear	1	1	1	1							1	1	1	1				
34	109586	Coupling sleeve	2	2	2	2							2	2	2	2				
35	109665	Synchro assembly	1	1	1	1							1	1	1	1				
36	109664	Circlips	1	1	1	1							1	1	1	1				
37	561774	4th gear	1	1	1	1							1	1	1	1				
38	561784	Washer	1	1	1	1							1	1	1	1				
39	561788	Bearing	1	1	1	1							1	1	1	1				
40	550632	Plug	1	1	1	1							1	1	1	1				
41	109665	Synchro assembly	1	1	1	1							1	1	1	1				
42	109568	Output shaft, 1st gear	1	1	1	1							1	1	1	1				
43	109621	Bearing	2	2	2	2							2	2	2	2				
44	109653	Spacer	1	1	1	1							1	1	1	1				
45	109652	Coupling	1	1	1	1							1	1	1	1				
46	551373	Spacer	1	1	1	1							1	1	1	1				
47	109656	Seal	1	1	1	1							1	1	1	1				
48	561807	End yoke	1	1	1	1							1	1	1	1				
49	550636	O-ring	1	1	1	1							1	1	1	1				
50	109798	Washer	1	1	1	1							1	1	1	1				
51	561810	Screw	1	1	1	1							1	1	1	1				
52	561814	1st and 2nd shift rod	1	1	1	1							1	1	1	1				
53	561815	3rd and 4th shift rod	1	1	1	1							1	1	1	1				
54	109709	Ball	3	3	3	3							3	3	3	3				

			QUANTITY / MODEL												BP 76							
3 TRANSMISSION, 4-SPEED, 2WD, INTERNAL COMPONENTS																						
ITEM	PART NO.	DESCRIPTION	M30-2T	M40-2T	M50-2T								M30-2T L	M40-2T L	M50-2T L							
55	473920	Spring	2	2	2	2							2	2	2	2						
56	550705	Plug	1	1	1	1							1	1	1	1						
57	109657	O-ring	1	1	1	1							1	1	1	1						
58	561812	1st and 2nd shift fork	1	1	1	1							1	1	1	1						
59	561813	3rd and 4th shift fork	1	1	1	1							1	1	1	1						
60	109737	Screw	2	2	2	2							2	2	2	2						
70	561932	Clutch pack kit	A/R	A/R	A/R	A/R							A/R	A/R	A/R	A/R						
71	561933	Complete clutch pack kit	A/R	A/R	A/R	A/R							A/R	A/R	A/R	A/R						
72	561934	Small parts kit	A/R	A/R	A/R	A/R							A/R	A/R	A/R	A/R						
73	562001	Bearing kit	A/R	A/R	A/R	A/R							A/R	A/R	A/R	A/R						
74	562002	Seal kit	A/R	A/R	A/R	A/R							A/R	A/R	A/R	A/R						
75	562003	Seal kit	A/R	A/R	A/R	A/R							A/R	A/R	A/R	A/R						
76	562004	Circlip kit	A/R	A/R	A/R	A/R							A/R	A/R	A/R	A/R						
77	562005	Washer kit	A/R	A/R	A/R	A/R							A/R	A/R	A/R	A/R						
78	561940	Thrust washer kit	A/R	A/R	A/R	A/R							A/R	A/R	A/R	A/R						
79	561942	Complete repair kit	A/R	A/R	A/R	A/R							A/R	A/R	A/R	A/R						
80	602729	Input shaft	1	1	1	1							1	1	1	1						
81	602730	Bushing	2	2	2	2							2	2	2	2						
82	702819	Piston kit	2	2	2	2							2	2	2	2						
83	705892	Clutch pack kit	A/R	A/R	A/R	A/R							A/R	A/R	A/R	A/R						
84	703472	Complete clutch pack kit	A/R	A/R	A/R	A/R							A/R	A/R	A/R	A/R						

BP 203
TIER III

TRANSMISSION, 4-SPEED, 2/4WD, CONTROL VALVE
TRANSMISSION REF: 222572 TYPE: 15984
TRANSMISSION REF: 222573 TYPE: 15985

M30-2T	M30-4T		
M40-2T	M40-4T		
M50-2T	M50-4T		
M30-2T L	M30-4T L		
M40-2T L	M40-4T L		
M50-2T L	M50-4T L		

POUR BOITE DE VITESSE
FÜR GETREIBEKASTEN
PARA CAJA DE VELOCIDADES
FOR GEAR BOX
PER CAMBIO

A PARTIR DE LA BOITE DE VITESSE
AB DER GETREIBEKASTEN
A PARTIR DE LA CAJA DE VELOCIDADES
FROM GEAR BOX
A PARTIR DEL CAMBIO

□ Type: **15984** Réf: **222 572**
□ Type: **15985** Réf: **222 573**

↳ N°: **2639**
↳ N°: **2208**

■ KIT COMPLET, VOIR NOMENCLATURE
KOMPLETTER KIT, SIEHE STÜCKLISTE
JUEGO COMPLETO, VER NOMENCLATURA
COMPLETE KIT, SEE NOMENCLATURE
KIT COMPLETO, VEDERE NOMENCLATURA

Rep - Hinw - Fig - Item - Sequenza
8

★ NON LIVRE AVEC REP. 1
NICHT GELIEFERT MIT HINW. 1
NO ENTREGADOS CON FIG. 1
NOT DELIVERED WITH ITEM. 1
NO CONSEGNARE CON SEQU. 1

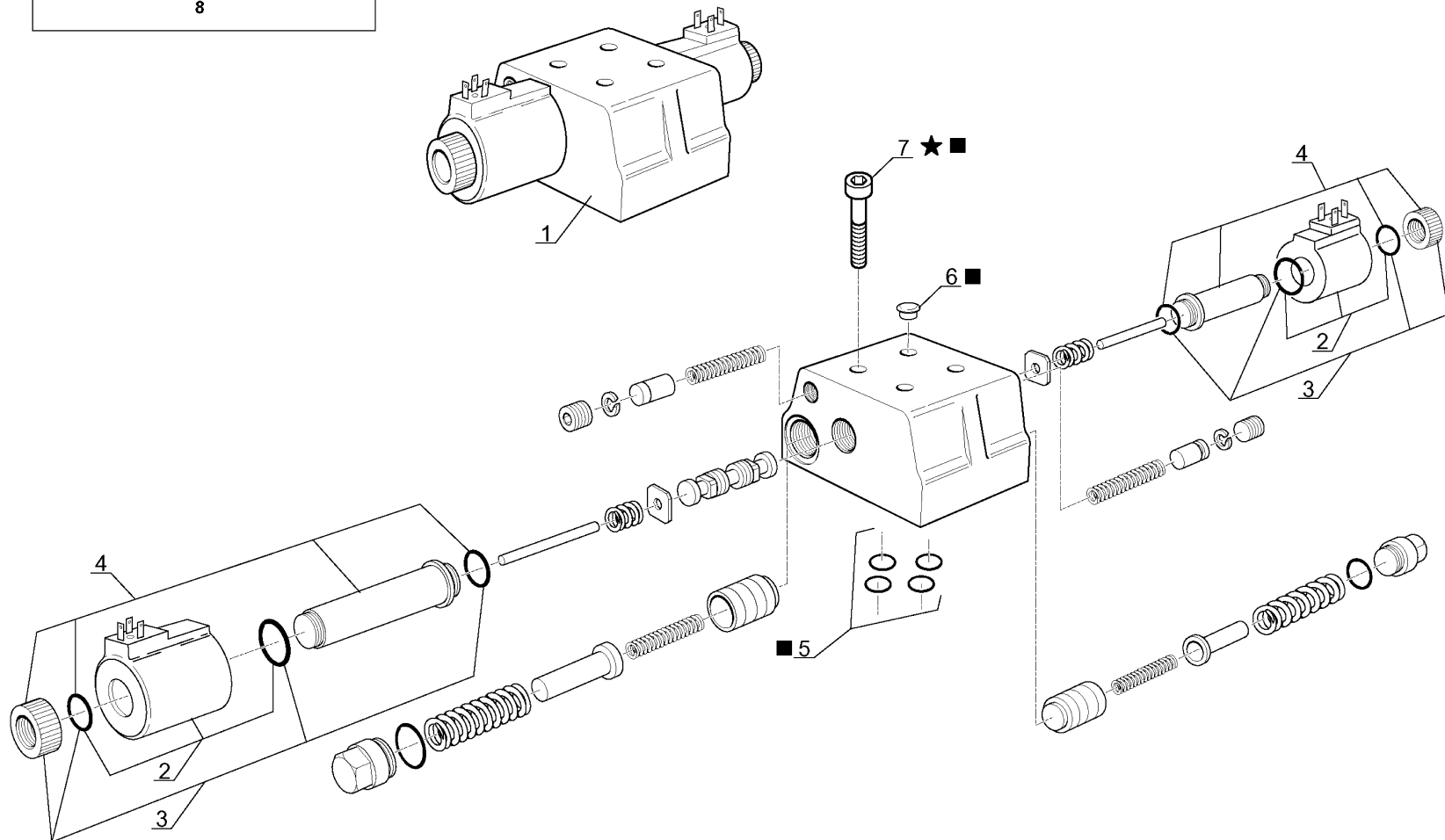

1	TRANSMISSION, 4-SPEED, 2WD, CONTROL VALVE		QUANTITY / MODEL										BP 203						
			M30-4T	M40-4T	M50-4T						M30-4T L	M40-4T L	M50-4T L						
ITEM	PART NO.	DESCRIPTION	M30-2T	M40-2T	M50-2T							M30-2T L	M40-2T L	M50-2T L					
1	702639	Electrical control valve	1	1	1	1						1	1	1	1				
2	702381	Solenoid	2	2	2	2						2	2	2	2				
3	702382	Small parts kit	1	1	1	1						1	1	1	1				
4	702383	Solenoid bracket	1	1	1	1						1	1	1	1				
5	561943	Seal kit	1	1	1	1						1	1	1	1				
6	562043	Plug	4	4	4	4						4	4	4	4				
7	561829	Screw	4	4	4	4						4	4	4	4				
8	702384	Small parts kit	1	1	1	1						1	1	1	1				

116.00

BP 181
TIER III

TRANSMISSION, 4-SPEED, 4WD
TRANSMISSION REF: 222573 TYPE: 15985

M30-4T
M40-4T
M50-4T

M30-4T L
M40-4T L
M50-4T L

SEE **4AA606** FOR DIPSTICK ASSEMBLY

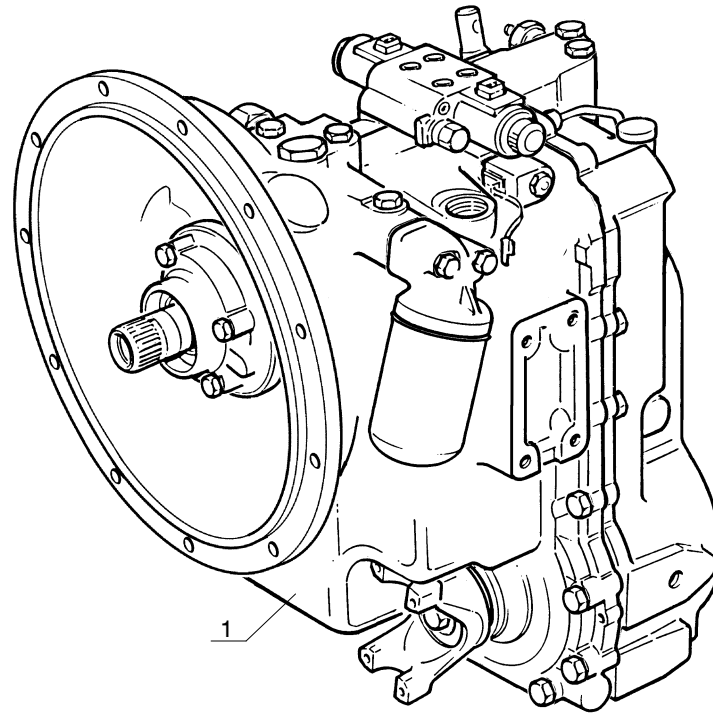

			QUANTITY / MODEL											BP 181				
			M30-4T	M40-4T	M50-4T							M30-4T L	M40-4T L	M50-4T L				
ITEM	PART NO.	DESCRIPTION																
1		TRANSMISSION, 4-SPEED, 4WD																
1	222573	Gear box, complete	1	1	1	1						1	1	1	1			

BP 182
TIER III

TRANSMISSION, 4-SPEED, 4WD, EXTERNAL COMPONENTS
TRANSMISSION REF: 222573 TYPE: 15985

M30-4T
M40-4T
M50-4T

M30-4T L
M40-4T L
M50-4T L

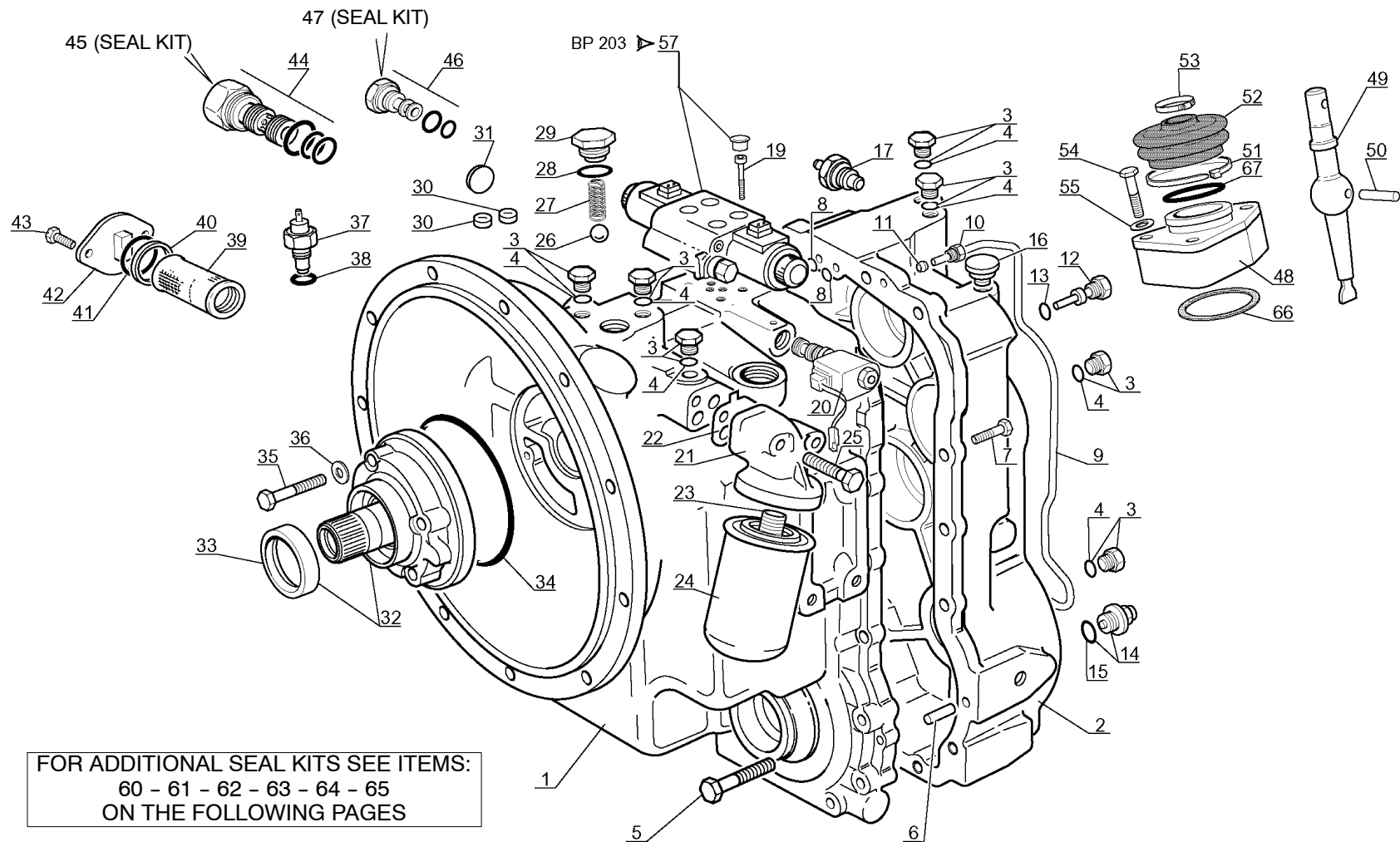

FOR ADDITIONAL SEAL KITS SEE ITEMS:
60 - 61 - 62 - 63 - 64 - 65
ON THE FOLLOWING PAGES

			QUANTITY / MODEL											BP 182				
1 TRANSMISSION, 4-SPEED, 4WD, EXTERNAL COMPONENTS			M30-4T	M40-4T	M50-4T							M30-4T L	M40-4T L	M50-4T L				
ITEM	PART NO.	DESCRIPTION																
1	561757	Transmission housing	1	1	1	1						1	1	1	1			
2	561758	Transmission rear case	1	1	1	1						1	1	1	1			
3	550705	Plug	13	13	13	13						13	13	13	13			
4	109657	O-ring	13	13	13	13						13	13	13	13			
5	561759	Screw	4	4	4	4						4	4	4	4			
6	109703	Stud bolt	2	2	2	2						2	2	2	2			
7	109727	Screw	13	13	13	13						13	13	13	13			
8	561833	O-ring	4	4	4	4						4	4	4	4			
9	561825	Pipe	1	1	1	1						1	1	1	1			
10	561824	Nut	2	2	2	2						2	2	2	2			
11	561826	Bushing	2	2	2	2						2	2	2	2			
12	561835	Plug	1	1	1	1						1	1	1	1			
13	109657	O-ring	1	1	1	1						1	1	1	1			
14	473366	Drain plug	1	1	1	1						1	1	1	1			
15	147915	O-ring	1	1	1	1						1	1	1	1			
16	109705	Air breather	1	1	1	1						1	1	1	1			
17	705009	Oil pressure switch	1	1	1	1						1	1	1	1			
19	561829	Screw	4	4	4	4						4	4	4	4			
20	561831	Solenoid	1	1	1	1						1	1	1	1			
21	561837	Filter housing	1	1	1	1						1	1	1	1			
22	109646	Gasket	1	1	1	1						1	1	1	1			
23	109658	Connection	1	1	1	1						1	1	1	1			
24	561749	Oil filter	1	1	1	1						1	1	1	1			
25	109728	Screw	2	2	2	2						2	2	2	2			
26	561836	Ball	1	1	1	1						1	1	1	1			
27	561765	Spring	1	1	1	1						1	1	1	1			
28	561827	O-ring	1	1	1	1						1	1	1	1			

118.00

			QUANTITY / MODEL											BP 182									
			M30-4T	M40-4T	M50-4T							M30-4T L	M40-4T L	M50-4T L									
2	TRANSMISSION, 4-SPEED, 4WD, EXTERNAL COMPONENTS																						
ITEM	PART NO.	DESCRIPTION																					
29	561828	Plug	1	1	1	1										1	1	1	1				
30	561822	Plug	2	2	2	2										2	2	2	2				
31	561834	Plug	1	1	1	1										1	1	1	1				
32	561930	Complete pump	1	1	1	1										1	1	1	1				
33	109690	Seal	1	1	1	1										1	1	1	1				
34	109676	O-ring	1	1	1	1										1	1	1	1				
35	561760	Screw	4	4	4	4										4	4	4	4				
36	109659	Washer	4	4	4	4										4	4	4	4				
37	702388	Oil temp sensor	1	1	1	1										1	1	1	1				
38	109657	O-ring	1	1	1	1										1	1	1	1				
39	109565	Suction strainer	1	1	1	1										1	1	1	1				
40	550626	Washer	1	1	1	1										1	1	1	1				
41	550627	O-ring	1	1	1	1										1	1	1	1				
42	473368	Cover	1	1	1	1										1	1	1	1				
43	109732	Screw	2	2	2	2										2	2	2	2				
44	561830	Pressure regulation valve	1	1	1	1										1	1	1	1				
45	561946	Seal kit	1	1	1	1										1	1	1	1				
46	561823	Over pressure valve	1	1	1	1										1	1	1	1				
47	561945	Seal kit	1	1	1	1										1	1	1	1				
48	562040	Upper seat	1	1	1	1										1	1	1	1				
49	561816	Gear lever foot	1	1	1	1										1	1	1	1				
50	109681	Pin	1	1	1	1										1	1	1	1				
51	561820	Clamp	1	1	1	1										1	1	1	1				
52	109612	Dust cover	1	1	1	1										1	1	1	1				
53	561821	Clamp	1	1	1	1										1	1	1	1				
54	561760	Screw	3	3	3	3										3	3	3	3				
55	561761	Washer	3	3	3	3										3	3	3	3				

3	TRANSMISSION, 4-SPEED, 4WD, EXTERNAL COMPONENTS		QUANTITY / MODEL												BP 182						
			M30-4T	M40-4T	M50-4T							M30-4T L	M40-4T L	M50-4T L							
ITEM	PART NO.	DESCRIPTION																			
57	702639	Electrical control valve	1	1	1	1								1	1	1	1				
60	561931	Pump kit	A/R	A/R	A/R	A/R								A/R	A/R	A/R	A/R				
61	561934	Small parts kit	A/R	A/R	A/R	A/R								A/R	A/R	A/R	A/R				
62	561936	Seal kit	A/R	A/R	A/R	A/R								A/R	A/R	A/R	A/R				
63	561937	Seal kit	A/R	A/R	A/R	A/R								A/R	A/R	A/R	A/R				
64	561941	Tube kit	A/R	A/R	A/R	A/R								A/R	A/R	A/R	A/R				
65	562148	Complete repair kit	A/R	A/R	A/R	A/R								A/R	A/R	A/R	A/R				
66	600366	O-ring	1	1	1	1								1	1	1	1				
67	600365	Gasket	1	1	1	1								1	1	1	1				

BP 183
TIER III

TRANSMISSION, 4-SPEED, 4WD, INTERNAL COMPONENTS
TRANSMISSION REF: 222573 TYPE: 15985

M30-4T
M40-4T
M50-4T

M30-4T L
M40-4T L
M50-4T L

FOR ADDITIONAL SEAL KITS SEE ITEMS:
- 92 - 93 - 94 - 95 - 96 - 97 - 98 - 103 □
- 104 □
ON THE FOLLOWING PAGES

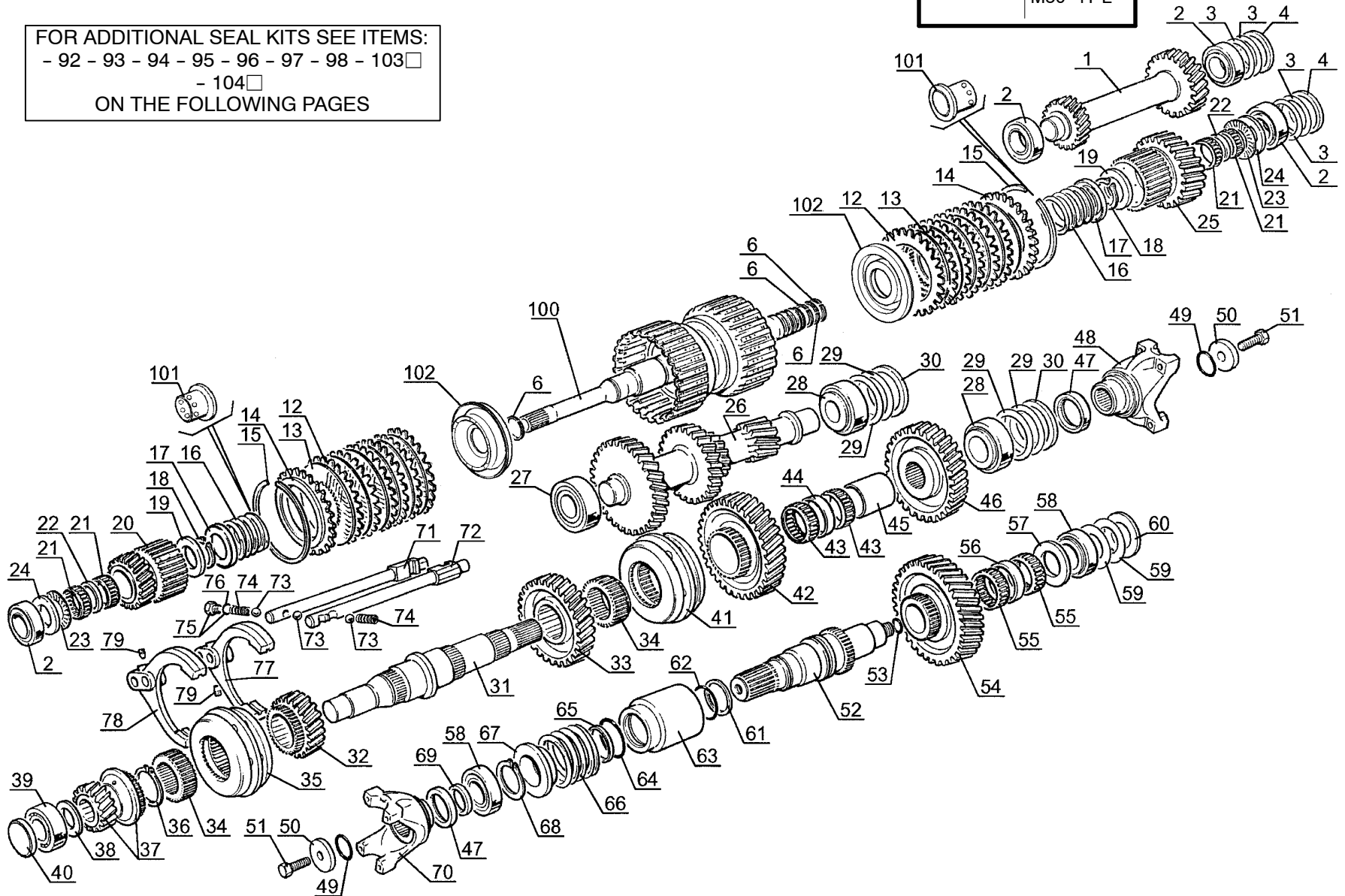

			QUANTITY / MODEL											BP 183				
1 TRANSMISSION, 4-SPEED, 4WD, INTERNAL COMPONENTS			M30-4T	M40-4T	M50-4T							M30-4T L	M40-4T L	M50-4T L				
ITEM	PART NO.	DESCRIPTION																
1	561791	Reverse idler gear	1	1	1	1						1	1	1	1			
2	109701	Bearing	4	4	4	4						4	4	4	4			
3	109615	Shim .051mm (.002 in)	4	4	4	4						4	4	4	4			
3	109616	Shim .076mm (.003 in)	A/R	A/R	A/R	A/R						A/R	A/R	A/R	A/R			
3	109617	Shim .127mm (.005 in)	A/R	A/R	A/R	A/R						A/R	A/R	A/R	A/R			
3	109618	Shim .178mm (.007 in)	A/R	A/R	A/R	A/R						A/R	A/R	A/R	A/R			
3	109619	Shim .381mm (.015 in)	A/R	A/R	A/R	A/R						A/R	A/R	A/R	A/R			
3	109620	Shim .508mm (.020 in)	A/R	A/R	A/R	A/R						A/R	A/R	A/R	A/R			
4	109597	Spacer	2	2	2	2						2	2	2	2			
5	561792	Input shaft	1	1	1	1						1	1	1	1			
6	109624	Seal	4	4	4	4						4	4	4	4			
12	561797	Clutch disc	12	12	12	12						12	12	12	12			
13	561798	Friction disc	12	12	12	12						12	12	12	12			
14	561796	Plate	2	2	2	2						2	2	2	2			
15	561795	Circlips	2	2	2	2						2	2	2	2			
16	561801	Spring	2	2	2	2						2	2	2	2			
17	561800	Bushing	2	2	2	2						2	2	2	2			
18	561799	Circlips	2	2	2	2						2	2	2	2			
19	561789	Thrust washer	2	2	2	2						2	2	2	2			
20	561793	Forward primary gear	1	1	1	1						1	1	1	1			
21	109651	Roller bearing	4	4	4	4						4	4	4	4			
22	561809	Spacer	2	2	2	2						2	2	2	2			
23	561762	Bearing	2	2	2	2						2	2	2	2			
24	561764	Stop washer	2	2	2	2						2	2	2	2			
25	561794	Backward primary gear	1	1	1	1						1	1	1	1			
26	561790	Countershaft	1	1	1	1						1	1	1	1			
27	109622	Bearing	1	1	1	1						1	1	1	1			

119.00

2	TRANSMISSION, 4-SPEED, 4WD, INTERNAL COMPONENTS		QUANTITY / MODEL												BP 183				
			M30-4T	M40-4T	M50-4T							M30-4T L	M40-4T L	M50-4T L					
ITEM	PART NO.	DESCRIPTION																	
28	561786	Bearing	2	2	2	2							2	2	2	2			
29	109599	Shim .051mm (.002 in)	A/R	A/R	A/R	A/R							A/R	A/R	A/R	A/R			
29	109600	Shim .076mm (.003 in)	A/R	A/R	A/R	A/R							A/R	A/R	A/R	A/R			
29	109601	Shim .178mm (.007 in)	A/R	A/R	A/R	A/R							A/R	A/R	A/R	A/R			
29	109602	Shim .559mm (.020 in)	A/R	A/R	A/R	A/R							A/R	A/R	A/R	A/R			
30	109598	Spacer	2	2	2	2							2	2	2	2			
31	561785	Output shaft	1	1	1	1							1	1	1	1			
32	561775	3rd gear	1	1	1	1							1	1	1	1			
33	561776	2nd gear	1	1	1	1							1	1	1	1			
34	109586	Coupling sleeve	2	2	2	2							2	2	2	2			
35	109665	Synchro assembly	1	1	1	1							1	1	1	1			
36	109664	Circlips	1	1	1	1							1	1	1	1			
37	561774	4th gear	1	1	1	1							1	1	1	1			
38	561784	Washer	1	1	1	1							1	1	1	1			
39	561788	Bearing	1	1	1	1							1	1	1	1			
40	550632	Plug	1	1	1	1							1	1	1	1			
41	109665	Synchro assembly	1	1	1	1							1	1	1	1			
42	109568	Output shaft 1st gear	1	1	1	1							1	1	1	1			
43	109621	Bearing	2	2	2	2							2	2	2	2			
44	109653	Spacer	1	1	1	1							1	1	1	1			
45	109652	Coupling	1	1	1	1							1	1	1	1			
46	561777	Output shaft drive gear	1	1	1	1							1	1	1	1			
47	109656	Seal	2	2	2	2							2	2	2	2			
48	561807	End yoke	1	1	1	1							1	1	1	1			
49	550636	O-ring	2	2	2	2							2	2	2	2			
50	109798	Washer	2	2	2	2							2	2	2	2			

3	TRANSMISSION, 4-SPEED, 4WD, INTERNAL COMPONENTS		QUANTITY / MODEL												BP 183			
			M30-4T	M40-4T	M50-4T							M30-4T L	M40-4T L	M50-4T L				
ITEM	PART NO.	DESCRIPTION																
51	561810	Screw	2	2	2	2							2	2	2	2		
52	561771	Output shaft	1	1	1	1							1	1	1	1		
53	561778	O-ring	1	1	1	1							1	1	1	1		
54	561772	Gear (37 teeth)	1	1	1	1							1	1	1	1		
55	561838	Roller bearing	2	2	2	2							2	2	2	2		
56	561839	Spacer	1	1	1	1							1	1	1	1		
57	561773	Washer	1	1	1	1							1	1	1	1		
58	561787	Bearing	2	2	2	2							2	2	2	2		
59	561780	Shim	A/R	A/R	A/R	A/R							A/R	A/R	A/R	A/R		
59	561781	Shim	A/R	A/R	A/R	A/R							A/R	A/R	A/R	A/R		
59	561782	Shim	A/R	A/R	A/R	A/R							A/R	A/R	A/R	A/R		
59	561783	Shim	A/R	A/R	A/R	A/R							A/R	A/R	A/R	A/R		
60	561779	Spacer	1	1	1	1							1	1	1	1		
61	561763	Seal	1	1	1	1							1	1	1	1		
62	561766	O-ring	1	1	1	1							1	1	1	1		
63	561768	Coupling	1	1	1	1							1	1	1	1		
64	561818	O-ring	1	1	1	1							1	1	1	1		
65	561819	Seal	1	1	1	1							1	1	1	1		
66	561769	Spring	1	1	1	1							1	1	1	1		
67	561770	Spring bracket	1	1	1	1							1	1	1	1		
68	561767	Circlips	1	1	1	1							1	1	1	1		
69	561808	Spacer	1	1	1	1							1	1	1	1		
70	561807	End yoke	1	1	1	1							1	1	1	1		

4	TRANSMISSION, 4-SPEED, 4WD, INTERNAL COMPONENTS		QUANTITY / MODEL												BP 183			
			M30-4T	M40-4T	M50-4T							M30-4T L	M40-4T L	M50-4T L				
ITEM	PART NO.	DESCRIPTION																
71	561814	1st and 2nd shift rod	1	1	1	1							1	1	1	1		
72	561815	3rd and 4th shift rod	1	1	1	1							1	1	1	1		
73	109709	Ball	3	3	3	3							3	3	3	3		
74	473920	Spring	2	2	2	2							2	2	2	2		
75	550705	Plug	1	1	1	1							1	1	1	1		
76	109657	O-ring	1	1	1	1							1	1	1	1		
77	561812	1st and 2nd shift fork	1	1	1	1							1	1	1	1		
78	561813	3rd and 4th shift fork	1	1	1	1							1	1	1	1		
79	109737	Screw	2	2	2	2							2	2	2	2		
92	561934	Small parts kit	A/R	A/R	A/R	A/R							A/R	A/R	A/R	A/R		
93	561935	Bearing kit	A/R	A/R	A/R	A/R							A/R	A/R	A/R	A/R		
94	561936	Seal kit	A/R	A/R	A/R	A/R							A/R	A/R	A/R	A/R		
95	561937	Seal kit	A/R	A/R	A/R	A/R							A/R	A/R	A/R	A/R		
96	561938	Circlip kit	A/R	A/R	A/R	A/R							A/R	A/R	A/R	A/R		
97	561939	Washer kit	A/R	A/R	A/R	A/R							A/R	A/R	A/R	A/R		
98	561940	Thrust washer kit	A/R	A/R	A/R	A/R							A/R	A/R	A/R	A/R		
100	602729	Input shaft	1	1	1	1							1	1	1	1		
101	602730	Bushing	2	2	2	2							2	2	2	2		
102	702819	Piston kit	2	2	2	2							2	2	2	2		
103	705892	Clutch pack kit	A/R	A/R	A/R	A/R							A/R	A/R	A/R	A/R		
104	703472	Complete clutch pack kit	A/R	A/R	A/R	A/R							A/R	A/R	A/R	A/R		

PARTS INDEX: *Part no., Item no., Page (Assembly Ref. no.)*

CATALOG 809816, R02-09

105101	52, BP182-2	109705	133570	168379, 11, 6AA367-1	57, 8AA464-3	192310
6, AX1851-1	109615, 3, BP76-1,	12, BP178-1	19, AX1581-1	168494, 61, 10AE736-3	75, 8AA463-3	19, 11AA1035-1,
8, AX1582-1	BP183-1	16, BP182-1	39, AX1449-2	168706, 6, 4AB152-1	184031, 79, 8AA463-3	11AA1036-1
105131, 19, AX1851-1	109616, 3, BP76-1,	33, 4AA606-2	133636	168758, 62, 10AE736-3	184035	6, 11BA120-1
105424, 9, AX1582-1	BP183-1	109709	2, AP1954-1	168870	61, 8AA463-3	192415, 2, 11BA122-1
105491, 9, AX1851-1	109617, 3, BP76-1,	54, BP76-2	7, AP1951-1	2, 8AA473-1,	77, 8AA463-3	192871, 18, 10DA318-1
106010, 2, AX1415-1	BP183-1	73, BP183-4	133637, 29, AP1952-2	8AA474-1	193161, 59, 8AA463-3	194661, 6, 8AA465-1
106080, 8, AX1450-1	109618, 3, BP76-1,	109727	133643, 30, AP1952-2	3, 8AA475-1	194668, 23, 8AA465-1	194668, 23, 8AA465-1
106533	BP183-1	5, BP178-1	133655	169437, 32, 7AA62-2	8AA467-1	194673
1, AX1868-1,	109619, 3, BP76-1,	7, BP182-1	10, AP1950-1	169917, 13, 11BA120-1	3, 9AA322-1	28, 8AA463-1
AX1580-1	BP183-1	109728	7, AP1952-1	170836, 3, 11BA103-1	35, 8AA464-2	3, 8AA464-1
10, AX1450-1	109620, 3, BP76-1,	20, BP178-1	133707, 5, AP1961-1	171912, 70, 8AA463-3	184130, 36, 6BB162-1	42, 8AA464-2
32, AX1582-2	BP183-1	25, BP182-1	133714, 4, AP1954-1	172569, 51, 6BB160-2	184526	43, 8AA463-2
106550, 4, AX1449-1,	109621, 43, BP76-2,	109732	133739	173717, 6, 8AA476-1	20, 11CC225-1	56, 8AA464-3
AX1581-1	BP183-2	38, BP178-2	20, AP1952-1	174132	29, 8AA465-1	74, 8AA463-3
106567, 42, AX1415-1	109622, 27, BP76-1,	43, BP182-2	25, AP1954-1	1, 11BA121-1	184642, 10, 6AA367-1	195069
106842, 13, AX1851-1	BP183-1	109737	133768, 5, AP1951-1	17, 8AA466-1	184817, 6, 11AA1035-1,	11AA1036-1
107286, 22, AX1415-1	109624, 6, BP76-1,	60, BP76-3	133770, 6, AP1951-1	2, 9AA322-1	11AA1036-1	16, 8AA475-1
107293	BP183-1	79, BP183-4	133831, 3, AP1950-1	24, 8AA463-1,	184818, 31, 8AA466-2	17, 8AA474-1
20, AX1581-1	109646	109751	133851, 32, AP1952-2	8AA466-1	185054, 1, 8AA472-1	17, 8AA473-1
41, AX1449-2	17, BP178-1	11, 7AB14-1	138200, 15, AP1962-1	35, 8AA463-2	187283, 11, 4AC223-1	195535, 23, 8AA464-1
107294, 42, AX1449-2	22, BP182-1	20, 6AA377-1	138222, 2, AP1950-1	4, 11AA1035-1,	187294, 12, 4AC223-1	187294, 12, 4AC223-1
107363	109651, 21, BP76-1,	6, 4AB149-1	139365, 9, AP1950-1	11AA1036-1,	187485, 24, 4AC223-1	187485, 24, 4AC223-1
12, AP1955-1	BP183-1	9, 6AA376-1	139495, 6, AP1955-1	11BA120-1	187898, 8, 10CE15-1	187898, 8, 10CE15-1
18, AP1954-1,	109652, 45, BP76-2,	109752	147915, 15, BP182-1	72, 8AA463-3	189172	189172
AP1964-1	BP183-2	10, 6AA376-1	160573, 60, 11AA1036-3	8, 4AB152-1,	1, 8AA663-1,	1, 8AA663-1,
20, AP1965-1	109653, 44, BP76-2,	12, 7AB14-1	162229	10AF592-1	8AA664-1	8AA664-1
23, AP1954-1	BP183-2	21, 6AA377-1	1, 9AA322-1	174321	15, 4AA627-1	15, 4AA627-1
107702, 8, AP1962-1	109656, 47, BP76-2,	5, 4AB149-1	16, 6BB163-1	3, 8AA473-1,	14, 11CC228-1	14, 11CC228-1
107751, 19, AX1415-1	BP183-2	109798, 50, BP76-2,	22, 8AA466-1	8AA474-1	2, 8AA504-1	2, 8AA504-1
107796	109657	BP183-2	34, 6BB160-2,	4, 8AA475-1	4, 6BB160-1	4, 6BB160-1
16, AX1582-1	13, BP182-1	109834, 5, AP1951-1	6BB162-1	174677	189535	189535
3, AX1415-1	33, BP178-2	109835, 6, AP1951-1	8, 8AA473-1,	10, 8AA464-1	19, 4AC223-1	19, 4AC223-1
5, AX1867-1,	38, BP182-2	109912, 7, AX1449-1,	8AA474-1	60, 8AA464-3	3, 10AA634-1	3, 10AA634-1
AX1584-1	4, BP178-1, BP182-1	AX1581-1	9, 8AA475-1,	175498	4, 10AA633-1	4, 10AA633-1
108100, 7, AX1582-1	57, BP76-3	129397, 15, 4AC223-1	AP1844-1	26, 6BB160-1	189536	189536
108127, 28, AP1952-1	76, BP183-4	133027, 53, AX1851-3	162809	30, 6BB161-2	18, 4AC223-1	18, 4AC223-1
108556, 61, AX1851-3	9, 11CD161-1,	133044	12, 6AA376-1	175743	2, 10AA634-1	2, 10AA634-1
108564, 10, AP1961-1	BP178-1	13, AX1868-1	14, 7AB14-1	26, 10DA318-1	3, 10AA633-1	3, 10AA633-1
109480	109658	50, AX1582-2	24, 6AA377-1	27, 10AA634-1	189752, 17, 8AA463-1	189752, 17, 8AA463-1
19, AX1450-1	18, BP178-1	9, AX1580-1	4, 4AB149-1	29, 10AE736-2	189857	189857
20, 3AA245-2	23, BP182-1	133055, 33, AX1851-2	164091, 14, 12AA463-1	7, 10DA320-1	16, 4AA627-1	16, 4AA627-1
109565	109659	133069	164965, 6, 4AA627-1	176737, 33, 11AA1035-2,	8, 8AA476-1,	8, 8AA476-1,
34, BP178-2	31, BP178-1	16, AX1581-1	165363, 15, 5AA101-1	11AA1036-2	11BA122-1,	11BA122-1,
39, BP182-2	36, BP182-2	33, AX1449-2	165919	176864, 6, 10AA633-1	AP1844-1	AP1844-1
109568, 42, BP76-2,	109664, 36, BP76-2,	133088, 8, AX1415-1	6, 8AA473-1,	177082, 7, 8AA476-1	190442	190442
BP183-2	BP183-2	133090, 1, AX1582-1	8AA474-1	177274, 20, 10AE736-1	1, 6BA214-1	1, 6BA214-1
109586, 34, BP76-2,	109665	133103	7, 8AA475-1	178696, 12, 10AF592-1	27, 6BB160-1	27, 6BB160-1
BP183-2	35, BP76-2, BP183-2	17, AX1582-1	166544, 68, 8AA464-3	179156	31, 6BB161-2	31, 6BB161-2
109597, 4, BP76-1,	41, BP76-2, BP183-2	4, AX1867-1,	166702, 16, 8AA465-1	33, 8AA466-2	190734	190734
BP183-1	109676	AX1584-1	167775, 57, 8AA463-3	48, 8AA463-2	45, 8AA464-2	45, 8AA464-2
109598, 30, BP76-2,	29, BP178-1	133118, 20, AX1851-1	168343	180602, 52, 8AA464-2	6, 8AA466-1	6, 8AA466-1
BP183-2	34, BP182-2	133131, 34, AX1851-2	11, 11CC225-1	182038, 2, 8AA463-1	190776, 13, 8AA464-1	190776, 13, 8AA464-1
109599, 29, BP76-2,	109681	133136, 5, AX1851-1	20, 11CC226-1	182101, 30, 8AA463-1	190807, 14, 6BB162-1	190807, 14, 6BB162-1
BP183-2	45, BP178-2	133138, 5, AX1851-1	168348, 58, 11AA1035-2,	182179, 4, 8AA463-1	191022, 15, 8AA479-1	191022, 15, 8AA479-1
109600, 29, BP76-2,	50, BP182-2	133173, 37, AX1449-2	11AA1036-2	182180, 5, 8AA463-1	191384, 9, 11AA1035-1,	191384, 9, 11AA1035-1,
BP183-2	109690	133177, 25, AX1851-2	168351	182181, 6, 8AA463-1	11AA1036-1	11AA1036-1
109601, 29, BP76-2,	28, BP178-1	133186, 6, AX1449-1,	23, 4AB149-1,	183396	191613	191613
BP183-2	33, BP182-2	AX1581-1	4AB151-1	18, 8AA466-1	13, 8AA473-1	13, 8AA473-1
109602, 29, BP76-2,	109701, 2, BP76-1,	133187, 35, AX1851-2	5, 8AA462-1	23, 8AA466-1	14, 8AA474-1	14, 8AA474-1
BP183-2	BP183-1	133199, 12, AX1415-1	168365	27, 8AA463-1	15, 8AA475-1	15, 8AA475-1
109612	109703, 6, BP178-1,	133276, 56, AX1851-3	10, 4AA605-1	34, 8AA463-2	18, 8AA476-1	18, 8AA476-1
47, BP178-2	BP182-1	133296, 27, AX1851-2	58, 4AB149-2	4, 8AA464-1	192093, 5, 10AE736-1	192093, 5, 10AE736-1

PARTS INDEX: Part no., Item no., Page (Assembly Ref. no.)

CATALOG 809816, R02-09

201149, 4, BC154-1	20, 8AA476-1	221172	243482, 15, 11AA1035-1,	273248, 14, 4AC223-1	4039, 29, 4AA606-2	20, 8AA464-1
201197, 32, BC154-2	21, 6BB163-1	44, 10AA636-1	11AA1036-1	273250, 25, 4AC223-1	409248, 12, BC154-1	34, 8AA466-2
201198	23, 8AA479-1	7, 10AA633-1	244242, 2, 11CD129-1	28959	41077, 32, 11AA1035-2,	43, 8AA464-2
23, BC154-1	25, 8AA463-1	221174, 2AA163-0	244289, 17, 11CD129-1	13, 6AA372-1,	11AA1036-2	66, 8AA464-3
9, BC154-1	41, 8AA464-2	38, 10AA636-1	246073, 6, 7AA64-1	8AA462-1	420431, 76, 4AB151-1	7, 4AC223-1
201199, 26, BC154-1	44, 8AA463-2	222381	246347, 32, 4AA606-2	16, 11AA1035-1,	420732, 4, 12AA463-1	6AA372-1
20125, 8, 11AA1035-1,	5, 9AA322-1	15, 6AA376-1	24653, 41, 12AA463-1	11AA1036-1	420772, 9, 12AA463-1	9, 8AA462-1,
11AA1036-1	73, 8AA463-3	29, 6AA377-1	247289	41, 8AA466-2	420774, 10, 12AA463-1	11CC225-1
201563, 12, 8AA476-1	205809, 73, 8AA464-3	222572	1, AX2551-1	68, 11AA1035-3,	420792, 12, 12AA463-1	42322
201931, 4, 8AA466-1	205933, 11, 8AA476-1	1, BP177-1	3, 7AB14-1	11AA1036-3	421116	12, 7AA62-1
201935, 64, 8AA464-3	206271, 3, 8AA463-1	14, 4AA606-1	247292, 2, AX2551-1,	29437	14, 3AA246-1	24, 11CD129-1
202144	206698, 1, 7AA62-1	222573	AX1854-1	12, 9AA322-1	29, 7AA62-2	28, 4AB149-2
1, 6BB163-1	207783, 3, 8AA472-1	1, BP181-1	247404, 33, 6BB161-2	2, 8AA483-1	57, 7AA62-2	9, 4AA606-1
16, 8AA474-1	207784, 66, 10BA302-1	11, 4AA606-1	247594, 4, 4AA601-1	20, 4AC223-1	421304, 55, 7AA62-2	42325
4, 8AA465-1	207785, 65, 10BA302-1	223246, 14, 11AA1035-1	248378, 10, 4AA603-1	3, 8AA462-1,	421305, 46, 7AA62-2	12, 8AA466-1
202226	208561, 51, 4AB151-1	223902, 7, 9AA322-1	248379, 9, 4AA603-1	8AA482-1	421306, 48, 7AA62-2	14, 10AA633-1
2, 10DA320-1	208701	223903, 8, 9AA322-1	249256, 14, 10AE736-1	6, 10AA634-1,	421307, 51, 7AA62-2	15, 10AE736-1
22, 10DA318-1	1, BC108-1	223904, 9, 9AA322-1	252947, 22, 4AA606-1	10AE736-1	421309, 52, 7AA62-2	15, 8AA473-1
43, 10AE736-2	45, 4AB151-1	224345, 10, 9AA322-1	252997, 23, 4AA606-1	8, 10AA633-1	421310, 54, 7AA62-2	16, 8AA476-1
202703, 25, 11AA1035-1,	209113, 4, 8AA472-1	224711, 27, 4AA601-1	254561, 2AA163-0	29441	421311, 53, 7AA62-2	2, 4AA602-1
11AA1036-1	209115, 6, 9AA322-1	224712, 28, 4AA601-1	29, 4AC223-1	13, 9AA322-1	421313, 47, 7AA62-2	21, 4AB152-1,
202731	209131, 2, 10AE736-1,	224713, 2AA163-0	254733	18, 8AA464-1	421314, 49, 7AA62-2	8AA479-1
10, 8AA474-1	10DA318-1	224759, 1, 11BA122-1	17, 6AA376-1	29469	421315, 56, 7AA62-2	26, 7AA62-2
11, 8AA475-1	209372, 15, 4AA606-1	224773, 64, 11AA1035-3,	25, 6AA377-1	13, 11CC228-1	421318	3, 6BB160-1,
13, 8AA466-1	209373, 17, 4AA606-1	11AA1036-3	25713	14, 6BB163-1	10, 7AA62-1	6BB163-1
2, 8AA663-1,	209374, 16, 4AA606-1	224774, 63, 11AA1035-3,	1, 8AA504-1	17, 11CC226-1	45, 7AA62-2	41, 4AA604-1
8AA664-1	209375, 54, 11AA1035-2,	11AA1036-3	5, 4AC223-1	19, 8AA464-1	421520, 14, 7AA62-1	46, 8AA464-2
4, 9AA322-1	11AA1036-2	224776, 1, 4AA601-1	67, 8AA464-3	2, 6BA214-1	421538, 50, 7AA62-2	49, 6BB160-2
202731, 11, 8AA504-1	209376, 18, 4AA606-1	224826, 5, 6AA372-1	7, 11BA122-1,	21, 8AA476-1	42231	5, 8AA466-1
202947, 2, 8AA472-1	209573, 20, 4AA606-1	226148	AP1844-1	23, 11AA1035-1,	10, 4AC223-1	53, 8AA463-2
202953	210005, 5, 8AA472-1	1, 4AB149-1	8, 8AA462-1	11AA1036-1	13, 4AB149-1,	55, 11AA1035-2,
4, 8AA473-1,	210006, 6, 8AA472-1	70, AX1851-3	9, 10AF592-1	26, 8AA464-1	4AB151-1	11AA1036-2
8AA474-1	210942, 31, 11AA1035-2,	79, 4AB151-1	25714	3, 8AA504-1,	2, 4AA606-1,	8, 8AA479-1
5, 8AA475-1	11AA1036-2	226807, 2, 4AA601-1	10, 11AA1035-1,	33, 6BB160-2,	6AA375-1	9, 8AA465-1
202954	211278, 7, 4AA627-1	229433, 6, 7AA62-1	11AA1036-1,	6BB162-1	28, 10AE736-2	423309, 3, 11CC228-1
5, 8AA473-1,	212021, 13, 12AA463-1	229587, 3, 4AA601-1	11CC225-1	4, 4AC223-1	43, 4AA604-1	423397, 21, 12AA463-1
8AA474-1	213400, 25, 10AA634-1	231403, 6, 11BA122-1	11, 9AA322-1,	43, 8AA466-2	5, 4AA605-1,	423398, 7, 12AA463-1
6, 8AA475-1	215875, 41, 11AA1035-2,	231464, 27, 11AA1036-1	10AF592-1	5, 8AA663-1,	4AB152-1	42347
203115	11AA1036-2	232402, 42, 11AA1035-2,	14, 8AA504-1	8AA664-1	6, 4AA601-1	16, 8AA479-1
1, 8AA473-1,	216000, 14, 8AA473-1	11AA1036-2	15, 11CC228-1	7, 8AA473-1,	42232	16, 8AA473-1
8AA474-1	2163, 12, 11BA120-1	233837	18, 6AA372-1	8AA474-1	11, 8AA473-1	17, 8AA476-1
19, 8AA476-1	217947, 10, 6BB160-1	22, 6BB160-1	19, 11CC226-1	8, 8AA475-1,	12, 8AA474-1	3, 4AA602-1
2, 8AA475-1	218013, 35, 6BB162-1	28, 6BB161-1	2, 11BA121-1	11CC225-1	13, 5AA101-1,	40, 4AA604-1
203123, 1, 8AA476-1	218074, 11, 6BB160-1	234267, 46, 4AB151-1	21, 8AA464-1	29475	8AA475-1	47, 6BB160-2
203124, 2, 8AA476-1	218075, 24, 6BB160-1	234292	22, 6BB163-1	5, 4AA601-1	15, 8AA476-1,	5, 10AA633-2
203125, 3, 8AA476-1	218083, 13, 8AA476-1	11, 10AA636-1	25, 8AA464-1	55, 4AB149-2,	9AA322-1	57, 11AA1035-2,
203126, 4, 8AA476-1	218177, 3, 6AA367-1	5, 10AA634-1	3, 8AA663-1,	4AB151-1	21, 4AC223-1	11AA1036-2
203127, 5, 8AA476-1	218178, 4, 6AA367-1	234798, 6, 12AA463-1	8AA664-1	6, 4AA606-1	22, 4AB149-1,	7, 4AA601-1
203452, 2, 8AA466-1	218179, 5, 6AA367-1	234799, 8, 12AA463-1	5, 11BA120-1	29483	4AB151-1	42349, 3, AX2551-1
203515, 18, 7AA62-1	218180, 6, 6AA367-1	234802, 5, 12AA463-1	65, 8AA464-3	15, 8AA464-1	3, 8AA483-1	423625, 1, 4AA602-1
203516, 22, 7AA62-1	218265, 12, 6AA367-1	234804, 39, 12AA463-1	7, 4AB152-1	53, 8AA464-2	4, 8AA482-1	4240, 8, 8AA468-1
203517, 23, 7AA62-1	218852, 47, 8AA463-2	237806	8, 4AC223-1	9, 8AA468-1	7, 4AA603-1,	42412, 5, 8AA465-1
203518, 24, 7AA62-1	219100, 73, 11AA1035-3	28, 6BB160-1	9, 11BA122-1	30327	10AE736-1	424186
203524, 20, 7AA62-1	219432, 24, 4AA606-1	32, 6BB161-2	25758	10, 8AA473-1	42256, 9, 4AB149-1	14, 8AA467-1
204069	219518, 12, 6AA367-1	240077, 5, 10AF592-1	17, 6AA372-1	11, 8AA474-1	42316	17, 9AA322-1
18, 6BB163-1	219533, 8, 11BA120-1	240821	76, 11AA1035-3	12, 8AA475-1	10, 10AF592-1	424647
39, 6BB162-1	219559	23, 6BB161-1	265765, 1, AP1844-1	31007, 8, 6AA372-1	12, 8AA472-1	11, 6AA376-1
204220, 32, 10AE736-2	21, 6BB161-1	9, 6BB160-1	270225, 31, 4AC223-2	3212, 14, 9AA322-1	14, 8AA504-1	13, 7AB14-1
205065, 41, 6BB160-2	29, 6BB160-2	241607, 9, 9AA323-1	271456	32963, 13, 6AA367-1	16, 9AA322-1	23, 6AA377-1
205250, 48, 8AA464-2	219834	242496	15, 6BB163-1	33593, 29, 4AB149-2	17, 11AA1035-1,	7, 4AB149-1
205257, 54, 8AA463-2	12, 6BB161-1	1, 4AA605-1	40, 6BB162-1	3411, 16, 4AC223-1	11AA1036-1	424764, 2AA163-0
205275	13, 6BB160-1	15, 4AB149-1	271498, 2, 6BB161-1	36010, 2, 4AA603-1	18, 11CC226-1	10, 10AA633-1
17, 8AA465-1	220370, 42, 6BB160-2	4, 4AA606-1	273244, 13, 4AC223-1	401831, 11, BC154-1	2, 6BB163-1	9, 10AA634-1

PARTS INDEX: *Part no., Item no., Page (Assembly Ref. no.)*

CATALOG 809816, R02-09

<p>424890, 51, 10AE736-2 425330 2, 6AA376-1 22, 6AA377-1 45, 4AB149-2 5, 7AB14-1 425481, 5, 11CD129-1 425493, 7, 11CD129-1 425494, 4, 11CD129-1 425495, 3, 11CD129-1 425497, 4, 10AA634-1 425501, 2AA163-0 19, 10AA634-1 20, 10AA633-1 425674, 15, 7AA62-1 426041, 4, 7AA62-1 426042, 33, 7AA62-2 426131, 19, 7AA62-1 426196, 25, 4AA601-1 426197, 24, 4AA601-1 426198, 26, 4AA601-1 426203, 22, 4AA601-1 426206, 20, 4AA601-1 426210, 69, 10AE736-3 426642, 44, 12AA463-1 426643, 19, 12AA463-1 426648, 14, 6AA377-1 426649, 16, 6AA377-1 426650 11, 6AA377-1 8, 7AA64-1 9, 7AB14-1 426688 7, 7AA64-1 8, 7AB14-1 42813 57, 4AB149-2 9, 4AA605-1 42818 23, 11CD129-1 26, 4AB149-2 44026 11, 9AA323-1 18, 9AA322-1 44672, 17, 4AA627-1 44807, 28, 4AA606-1 448834, 15, 6AA372-1 448930, 4, 7AA64-1 458502, 10, BC154-1 46668 12, 11AA1035-1, 11AA1036-1 13, 6BB163-1, 8AA472-1 27, 8AA464-1 38, 6BB162-1 470680, 2AA163-0 473290, 9, AP1959-1 473297, 6, AP1954-1 473299, 12, AP1962-1 473303, 13, AP1962-1 473309, 8, AP1955-1 473366</p>	<p>10, BP178-1 14, BP182-1 473368 37, BP178-2 42, BP182-2 473560, 10, AP1958-1 473908 22, AP1964-1 9, AP1964-1 473915, 11, BP178-1 473920 55, BP76-3 74, BP183-4 473939, 21, AP1965-1 473943 13, AP1958-1 15, AP1958-1 19, AP1965-1 30, AP1954-2 33, AP1954-2 473950, 28, AP1965-1 473951 16, AP1957-1 22, AP1954-1 473955 3, AP1964-1 5, AP1950-1 AP1955-1 473956, 24, AP1964-1 473958 26, AP1964-1 4, AP1962-1 473969 11, AP1961-1 3, AP1963-1 473971, 6, AP1962-1 473972, 7, AP1962-1 473973, 2, AP1962-1 473975, 3, AP1962-1 473976, 5, AP1962-1 473982, 3, AP1959-1 473986 15, AP1955-1 16, AP1965-1 4, AP1957-1 5, AP1958-1 8, AP1961-1 473988, 17, AP1955-1 473996, 12, AP1954-1 474005 24, AP1954-1 8, AP1957-1 474007, 3, AP1954-1 474018, 13, AP1956-1 474037, 21, AP1951-1 474038, 22, AP1951-1 474041, 20, AP1950-1 474056, 4, AP1955-1 474059, 5, AP1844-1 474060, 6, AP1844-1 474064 28, AP1954-1 43, AP1965-2</p>	<p>474067, 16, AP1964-1 474101, 6, AP1952-1 474105 11, AP1958-1 34, AP1954-2 474124, 20, AP1956-1 474129, 9, AP1955-1 474138, 16, AP1950-1 474298 17, AX1581-1 34, AX1449-2 474300 17, AX1581-1 34, AX1449-2 474313, 46, AX1582-2 474783, 24, BC154-1 475057, 4, AP1959-1 475059 14, AX1851-1 5, AX1415-1 475201, 10, AP1955-1 475260, 15, 3AA246-1 475379 19, 6BB163-1 43, 6BB162-1 475986, 17, AP1957-1 476018, 3, AP1957-1 476074 29, AP1954-2 4, AP1958-1 5, AP1959-1 476168, 2, AP1963-1 476318, 5, 10DA318-1 476321, 6, 10DA318-1 476322, 9, 10DA318-1 476324, 10, 10DA318-1 476325, 11, 10DA318-1 476341, 8, 10DA318-1 476850 13, 10DA318-1 14, 10DA318-1 15, 10DA318-1 4, 10DA320-1 476954, 2AA163-0 13, AP1957-1 477473 22, AX1449-1 57, AX1851-3 477474 21, AX1449-1 50, AX1851-3 477475, 29, AX1851-2 477476, 30, AX1851-2 477538, 2, AX1867-1, AX1584-1 477693, 27, AX1449-1 477781, 14, AP1955-1 477847, 12, AX1582-1 477964 1, AX1584-1 7, AX1867-1 478022, 5, AX1851-1 478547, 16, 6AA372-1</p>	<p>479218 21, 6BB160-1 8, 6BB161-1 479275, 67, 10BA302-1 48384, 36, 10AA636-1 487961, 1, 11BA103-1 488236 11, 10AA633-1 8, 10AA634-1 491718, 1, 11CC226-1 491746, 1, 8AA481-1 491779, 26, 12AA463-1 493481, 22, 12AA463-1 493789, 5, 6BB163-1 494918, 16, 12AA463-1 495931 12, 8AA479-1 2, 8AA481-1 3, 8AA480-1 496162, 24, 12AA463-1 496213, 11, 11CD161-1 496425, 12, AX1868-1 496430, 62, AX1851-3 496431, 64, AX1851-3 496538, 3, 12AA463-1 496653, 45, 12AA463-1 496680 2, 11BA120-1 3, 11BA121-1 496687, 50, 11AA1035-2, 11AA1036-2 496735, 17, 12AA463-1 496810, 12, 10AA635-1 496829, 25, 10AE736-1 496830, 19, 10AE736-1 496861, 31, 10AE736-2 496998, 2AA163-0 497922 30, 6BB160-2 34, 6BB161-2 508565, 2AA163-0 508802, 32, 4AB149-2 5239, 7, 10CE15-1 524789, 48, 4AB151-1 525596 14, 6AA376-1 27, 6AA377-1 5323, 60, 11AA1035-3 53501 19, 9AA322-1 8, 6BB160-1 5398 11, 6BB161-1 6, 6BB160-1 54232 10, 8AA468-1 14, 6AA372-1, 8AA462-1 16, 8AA467-1 20, 9AA322-1 22, 11AA1035-1, 11AA1036-1 50, 8AA464-2</p>	<p>67, 11AA1035-3, 11AA1036-3 7, 11BA120-1, 11CD134-1 54242 17, 8AA479-1 22, 11CD129-1 6, 8AA464-1 54557 21, 11CC225-1 30, 8AA465-1 54564, 22, 8AA465-1 54568 35, 8AA465-2 37, 8AA463-2 41, 8AA463-2 548112, 4, 10DA318-1 548894, 12, 10DA318-1 548898, 7, AP1955-1 549100, 10, 11CD161-1 549222, 8, 8AA467-1 54951 2, 6BB160-1 27, 6BB161-1 3, 11CD134-1 56, 11AA1035-2, 11AA1036-2 549672 17, 10DA318-1 5, 10DA320-1 549774, 16, 10DA318-1 550153, 5, 8AA467-1 550482, 4, AP1961-1 550493, 10, AP1956-1 550499, 19, AP1956-1 550507, 6, AP1957-1 550520, 68, 10AE736-3 550556 2, AX1581-1 38, AX1449-2 550557 2, AX1581-1 38, AX1449-2 550626 35, BP178-2 40, BP182-2 550627 36, BP178-2 41, BP182-2 550632, 40, BP76-2, BP183-2 550636, 49, BP76-2, BP183-2 550649, 8, 8AA466-1 550705 3, BP178-1, BP182-1 56, BP76-3 75, BP183-4 551239, 3, 10DA318-1 551242, 66, 10AE736-3 551255, 8, 4AA627-1 551256, 9, 4AA627-1 551257, 11, 4AA627-1</p>	<p>551258, 10, 4AA627-1 551259, 12, 4AA627-1 551373, 46, BP76-2 551451, 17, 8AA464-1 551500, 31, AP1965-2 551522, 70, 8AA464-3 551555 31, 8AA464-2 39, 8AA464-2 551556 32, 8AA464-2 38, 8AA464-2 551557, 37, 8AA464-2 551558 30, 8AA464-2 40, 8AA464-2 551560, 7, 8AA465-1 551582 1, 8AA465-1 11, 8AA465-1 2, 8AA465-1 551600 13, 8AA465-1 26, 8AA465-1 551615 17, AX1581-1 34, AX1449-2 551616 2, AX1581-1 38, AX1449-2 551662, 6, AP1961-1 551768, 7, 4AA602-1 551774, 13, 10CE15-1 551858, 12, AP1965-1 551859, 11, AP1965-1 551869, 16, 8AA466-1 551880 33, 8AA463-2 44, 8AA464-2 55, 8AA464-2 551882, 9, 8AA463-1 552418, 7, AP1959-1 552426, 1, 8AA463-1 552448, 55, 8AA463-2 552502, 8, 11CD161-1 552504, 33, BC154-2 552509, 4, AX1851-1 552510, 52, AX1851-3 552512, 36, AX1851-2 552513, 22, AX1851-1 552514, 16, AX1851-1 552515, 5, AX1851-1 552516 17, AX1581-1 34, AX1449-2 552517 2, AX1581-1 38, AX1449-2 552518, 11, AX1851-1 552522, 17, AX1851-1 552523, 48, AX1851-3 552524, 2, AX1851-1 552528, 58, AX1851-3</p>	<p>552531, 28, AX1851-2 552532, 49, AX1851-3 552537, 26, AX1851-2 552538, 21, AX1851-1 552608, 4, BC108-1 552622, 25, BC154-1 552629, 3, BC154-1 552634, 15, BC154-1 552670, 23, 8AA463-1 552672, 50, 8AA463-2 552682, 3, 8AA467-1 552709, 62, 8AA463-3 552760 19, 11CC225-1 3, 8AA465-1 552894, 16, AP1956-1 55404 22, 8AA464-1 24, 8AA464-1 554629, 4, 11BA103-1 5549 15, 6BB160-1 9, 6BB161-1 561086, 18, 8AA463-1 561087, 31, 8AA463-2 561088, 1, 8AA467-1 561089, 29, 8AA466-2 561090, 2, 8AA467-1 561091, 28, 8AA466-1 561092, 8, 8AA463-1 561093, 7, 8AA463-1 561110, 36, 8AA463-2 561187, 3, BC108-1 561198, 2, BC108-1 561248 45, 8AA463-2 56, 8AA463-3 561340, 7, 10DA318-1 561342, 37, 8AA465-2 561515, 16, 8AA463-1 561518, 20, 8AA463-1 561519, 26, 8AA463-1 561520, 29, 8AA463-1 561521, 32, 8AA463-2 561524, 2, 8AA464-1 561526, 16, 8AA464-1 561527 28, 8AA464-2 5, 8AA464-1 561528, 12, 8AA465-1 561529, 15, 8AA465-1 561531, 33, 8AA465-2 561535, 26, 8AA466-1 561540, 22, 8AA479-1 561544, 54, 8AA464-2 561620, 11, 10CE15-1 561621, 10, 10CE15-1 561622, 9, 10CE15-1 561623, 3, 10CE15-1 561624, 5, 10CE15-1 561625, 6, 10CE15-1 561637, 2, 10CE15-1 561749, 2AA163-0</p>
---	--	--	---	--	---	---

PARTS INDEX: Part no., Item no., Page (Assembly Ref. no.)

CATALOG 809816, R02-09

19, BP178-1	561795, 15, BP76-1, BP183-1	19, BP182-1	62, BP178-2	1, AX1581-1	562531, 2, AX1868-1, AX1580-1	564246, 43, AX1851-2
24, BP182-1	561796, 14, BP76-1, BP183-1	7, BP203-1	74, BP76-3	44, AX1449-2	562547, 1, AX1415-1	564247, 41, AX1851-2
561757, 1, BP182-1	561797, 12, BP76-1, BP183-1	561830	562003	562474, 5, AX1449-1, AX1581-1	562548, 4, AX1415-1	564248, 8, AX1851-1
561758, 2, BP182-1	561798, 13, BP76-1, BP183-1	39, BP178-2	63, BP178-2	562475, 14, AX1582-1	562550, 7, AX1415-1	564250, 31, AX1851-2
561759, 5, BP182-1	561799, 18, BP76-1, BP183-1	44, BP182-2	75, BP76-3	562476, 9, AX1449-1, AX1581-1	562554, 20, AX1415-1	564551, 9, AP1958-1
561760	561800, 17, BP76-1, BP183-1	561831, 20, BP182-1	562004, 76, BP76-3	562477, 10, AX1449-1, AX1581-1	562567, 1, AP1962-1	564679, 57, AX1582-2
30, BP178-1	561801, 16, BP76-1, BP183-1	561833	562005, 77, BP76-3	562478, 11, AX1449-1	562665, 38, 8AA465-2	564680, 57, AX1582-2
35, BP182-2	561807	7, BP178-1	562006, 64, BP178-2	562479, 12, AX1449-1, AX1581-1	562706, 77, 10AE736-3	564681, 57, AX1582-2
49, BP178-2	561808, 69, BP183-3	8, BP182-1	562040	562480, 13, AX1449-1, AX1581-1	562750, 2, AX1582-1	564693, 3, AX1867-1,
54, BP182-2	561809, 22, BP76-1, BP183-1	561834	43, BP178-2	562481, 14, AX1449-1	562752, 10, AX1582-1	AX1584-1
561761	561810, 51, BP76-2, BP183-3	26, BP178-1	48, BP182-2	562482, 15, AX1581-1	563226, 10, AP1951-1	564898, 19, AX1582-1
50, BP178-2	561812	31, BP182-2	562043, 6, BP203-1	562483	563233	564903, 18, AX1582-1
55, BP182-2	561818	561835	562046	562485	2, AP1952-1	565998
561762, 23, BP76-1, BP183-1	561819	12, BP182-1	32, 8AA466-2	562485	3, AP1952-1	14, AX1450-1
561763, 61, BP183-3	561820	8, BP178-1	49, 8AA463-2	562485	563415, 2AA163-0	34, AX1582-2
561764, 24, BP76-1, BP183-1	561821	561836	562051, 36, 8AA465-2	562485	563416, 2AA163-0	57446
561765	561822	21, BP178-1	562070, 64, 8AA463-3	562485	563417, 35, 4AA601-2	23, 4AC223-1
22, BP178-1	561823	26, BP182-1	562072	562485	563487, 34, 4AA601-2	6, 8AA479-1
27, BP182-1	561824	561837	65, 8AA463-3	562485	563488, 30, 4AA601-2	8, 8AA663-1,
561766, 62, BP183-3	561825	16, BP178-1	66, 8AA463-3	562485	563489, 31, 4AA601-2	8AA664-1
561767, 68, BP183-3	561826	21, BP182-1	68, 8AA463-3	562485	563497, 7, AX1851-1	5804
561768, 63, BP183-3	561827	561838, 55, BP183-3	69, 8AA463-3	562485	563501, 45, AX1851-2	14, 8AA476-1
561769, 66, BP183-3	561828	561839, 56, BP183-3	562086, 35, 10AA636-1	562485	563502, 37, AX1851-2	22, 9AA322-1
561770, 67, BP183-3	561829	561840, 1, BP178-1	562088, 37, 10AA636-1	562485	563506, 18, AP1956-1	49, 10AE736-2
561771, 52, BP183-3	561830	561841, 2, BP178-1	562089, 42, 10AA636-1	562485	563532, 7, AP1950-1	58112, 20, BC154-1
561772, 54, BP183-3	561831	561930	562090, 41, 10AA636-1	562485	56354	58113, 21, BC154-1
561773, 57, BP183-3	561832	27, BP178-1	562092, 39, 10AA636-1	562485	10, 6BB161-1,	581732, 34, 9AA322-2
561774, 37, BP76-2, BP183-2	561833	32, BP182-2	562093, 43, 10AA636-1	562485	10AE736-1	58523, 9, 11BA120-1
561775, 32, BP76-2, BP183-2	561834	561931, 60, BP178-2, BP182-3	562095, 40, 10AA636-1	562485	21, 9AA322-1	58525, 30, 4AC223-2
561776, 33, BP76-2, BP183-2	561835	561932, 70, BP76-3	562148, 65, BP182-3	562485	4, 8AA462-1	58528
561777, 46, BP183-2	561836	561933, 71, BP76-3	562173, 35, 8AA466-2	562485	7, 6BB160-1	10, 8AA465-1
561778, 53, BP183-3	561837	561934	562181, 38, 8AA463-2	562485	8, 4AA603-1	19, 4AB152-1
561779, 60, BP183-3	561838	61, BP178-2, BP182-3	562185, 2AA163-0	562485	563744, 9, AP1961-1	20, 8AA479-1
561780, 59, BP183-3	561839	72, BP76-3	46, 8AA463-2	562485	563758, 10, AP1965-1	26, 6BB161-1
561781, 59, BP183-3	561840	92, BP183-4	562186, 51, 8AA463-2	562485	563864, 42, 8AA463-2	27, 4AC223-1
561782, 59, BP183-3	561841	561935, 93, BP183-4	562187, 71, 8AA463-3	562485	563903, 6, AX1582-1	29, 4AA601-1
561783, 59, BP183-3	561842	561936	562188, 52, 8AA463-2	562485	563904, 43, AX1449-2	50, 6BB160-2,
561784, 38, BP76-2, BP183-2	561843	62, BP182-3	562189, 58, 8AA463-3	562485	563905, 16, AX1415-1	6BB162-1
561785, 31, BP76-2, BP183-2	561844	94, BP183-4	562190, 60, 8AA463-3	562485	563906, 26, AX1415-1	59, 11AA1035-2,
561786, 28, BP76-1, BP183-2	561845	561937	562192, 63, 8AA463-3	562485	564073	11AA1036-2
561787, 58, BP183-3	561846	63, BP182-3	562193, 67, 8AA463-3	562485	1, AX1851-1	6, 6BB163-1
561788, 39, BP76-2, BP183-2	561847	95, BP183-4	562196, 7, 8AA464-1	562485	77, 4AB151-1	8, 11CC226-1
561789, 19, BP76-1, BP183-1	561848	561938, 96, BP183-4	562197, 8, 8AA464-1	562485	564074, 46, AX1851-2	9, 8AA663-1,
561790, 26, BP76-1, BP183-1	561849	561939, 97, BP183-4	562198, 9, 8AA464-1	562485	564076, 3, AX1851-1	8AA664-1,
561791, 1, BP76-1, BP183-1	561850	561940	562199, 11, 8AA464-1	562485	564133	8AA479-1
561792, 5, BP183-1	561851	78, BP76-3	562201, 29, 8AA464-2	562485	13, AX1450-1	58530, 21, 11CD129-1
561793, 20, BP76-1, BP183-1	561852	98, BP183-4	562202, 33, 8AA464-2	562485	33, AX1582-2	58531
561794, 25, BP76-1, BP183-1	561853	561941, 64, BP182-3	562204, 47, 8AA464-2	562485	564147, 27, 8AA466-1	20, 4AB152-1
	561854	561942	562205, 58, 8AA464-3	562485	564148, 25, 8AA466-1	4, 11CC226-1
	561855	65, BP178-2	562207, 76, 8AA463-3	562485	564149, 10, 8AA466-1	58536, 9, 10AE736-1
	561856	79, BP76-3	562265, 35, AX1449-2	562485	564214, 44, AX1851-2	58538
	561857	561943, 5, BP203-1	562317, 5, BC108-1	562485	564215, 40, AX1851-2	1, 4AA603-1
	561858	561944	562318, 6, BC108-1	562485	564216, 42, AX1851-2	8, 10AE736-1
	561859	42, BP178-2	562319, 7, BC108-1	562485	564221, 73, AX1851-3	58546
	561860	561945	562320, 8, BC108-1	562485	564223, 10, AX1851-1	20, 4AB149-1
	561861	44, BP182-2	562354, 74, 10AE736-3	562485	564224, 72, AX1851-3	3, 4AA606-1
	561862	561946	562355, 75, 10AE736-3	562485	564226, 39, AX1851-2	4, 4AB152-1
	561863	40, BP178-2	562427, 5, AX1851-1	562485	564234, 14, AX1415-1	6, 4AA605-1
	561864	45, BP182-2	562461, 34, 10AA636-1	562485	564242, 63, AX1851-3	58548
	561865	561947, 32, AX1851-2	562470, 5, AX1868-1, AX1580-1	562485	564243, 47, AX1851-2	14, 4AB149-1
	561866	562001, 73, BP76-3	562472	562485	564245, 38, AX1851-2	21, 4AA606-1
	561867	562002		562485		23, 10DA318-1

PARTS INDEX: Part no., Item no., Page (Assembly Ref. no.)

CATALOG 809816, R02-09

3, 10DA320-1	601642, 7, AP1964-1	603312, 25, AX1449-1	34, AP1952-2	63, 10AE736-3	63727	702335, 2, AP1964-1
4, 10AE736-1	601673	603313, 46, AX1449-2	604924, 22, AP1952-1	61545, 17, 10AE736-1	1, 8AA483-1	702336, 1, AP1960-1
7, 4AA605-1	13, AP1965-1	603316, 23, AX1450-1	604925, 23, AP1952-1	61674	14, 5AA101-1	702381, 2, BP203-1
8, 4AA601-1	3, 11CD161-1	603317, 30, AX1450-1	604928	10, 8AA663-1,	22, 4AC223-1	702382, 3, BP203-1
58552, 2, 4AA627-1	601828, 10, AP1962-1	603433, 22, AP1950-1	26, AP1952-1	8AA664-1,	5, 8AA482-1	702383, 4, BP203-1
58557, 8, 4AB149-1	601829, 16, AP1962-1	603534, 2, BC154-1	5, 11CD161-1	8AA475-1	7, 10AA634-1	702384, 8, BP203-1
58574, 21, 7AA62-1	601935, 2, AX1449-1	603638	604931, 2, AP1953-1	11, 8AA466-1	9, 10AA633-1	702388
58588, 10, 4AA606-1	601937, 18, AX1449-1	26, AX1582-1	604932, 3, AP1953-1	14, AP1844-1	63754	32, BP178-2
58633	601941, 16, AX1449-1	4, AX1450-1	604934, 7, AP1953-1	18, 4AB152-1	16, 10AE736-1	37, BP182-2
1, 7AB14-1	601943, 17, AX1449-1	6, AX1868-1,	604936, 11, AP1953-1	25, 6BB161-1	2, 7AA62-1	702418
13, 6AA377-1	601944, 28, AX1449-1	AX1580-1	604937, 12, AP1953-1	26, 4AC223-1	63936, 9, 6AA367-1	25, AX1582-1
4, AX2551-1,	601945, 1, AX1449-1	603639	604938, 13, AP1953-1	36, 8AA464-2	675, 10, 11BA120-1	7, AX1868-1
AX1854-1	601946, 29, AX1449-2	5, AX1450-1	604939, 14, AP1953-1	4, 8AA504-1,	676, 11, 11BA120-1	AX1580-1
7, 8AA472-1	601947, 30, AX1449-2	7, AX1868-1	604941, 13, AP1954-1	11CD134-1	686343, 1, 11AA1035-1,	702494, 2AA163-0
600365	601948, 31, AX1449-2	603640, 26, AX1450-1	604943, 15, AP1954-1	40, 8AA466-2	11AA1036-1	10, AP1844-1
66, BP178-2	601949, 23, AX1449-1	603648, 3, AX1581-1	604944, 16, AP1954-1	48, 6BB160-2,	702000, 1, AP1951-1	702618, 20, AP1951-1
67, BP182-3	601950, 32, AX1449-2	603650, 11, AX1582-1	604945, 17, AP1954-1	6BB162-1	702007, 7, AP1954-1	702619, 14, AP1962-1
600366	601983, 24, AX1851-2	603651, 13, AX1582-1	604950, 5, AP1954-1	7, 6BB163-1,	702008, 16, AP1955-1	702639
66, BP182-3	601998, 26, AX1449-1	603653, 23, AX1582-1	604954, 3, AP1955-1	8AA479-1,	702010, 17, AP1956-1	1, BP203-1
67, BP178-2	602007, 38, AX1415-1	603655, 60, AX1582-2	604958, 2, AP1956-1	11CC226-1	702012, 14, AP1957-1	52, BP178-2
600525, 28, BC154-1	602061, 7, BC154-1	603657	604960, 4, AP1956-1	70, 11AA1035-3,	702013, 15, AP1957-1	57, BP182-3
600549, 14, AX1868-1	602062, 16, BC154-1	5, AX1583-1	604961, 5, AP1956-1	11AA1036-3	702017, 1, AP1964-1	702657, 23, AP1950-1
600552, 25, AX1581-2	602063, 19, BC154-1	6, AX1583-1	604962, 6, AP1956-1	8, 8AA465-1	702018, 5, AP1964-1	702660, 14, AP1958-1
600558, 37, AX1415-1	602064, 22, BC154-1	603838, 31, AP1954-2	604963, 7, AP1956-1	9, 4AA601-1,	702019, 4, AP1964-1	702715, 67, 10AE736-3
600559, 15, AX1582-1	602065, 29, BC154-2	603844, 1, 8AA464-1	604964, 8, AP1956-1	8AA474-1	702021	702733, 22, AP1965-1
600582, 36, AX1415-1	602072, 37, 8AA466-2	603845, 63, 8AA464-3	604965, 9, AP1956-1	61676	21, AP1964-1	702734, 25, AP1965-1
600593, 12, AX1851-1	602094, 12, 10AA636-1	603846, 39, 8AA465-2	604966, 12, AP1956-1	10, 4AA601-1	8, AP1964-1	702735, 23, AP1965-1
600594, 66, AX1851-3	602095, 16, 10AA636-1	603847, 40, 8AA465-2	604969, 15, AP1956-1	12, 4AB149-1	702023	702736, 24, AP1965-1
600595, 18, AX1851-1	602096, 2AA163-0	603848, 41, 8AA465-2	604973	27, 10AE736-1	12, AP1964-1	702759, 1, AP1961-1
600596, 23, AX1851-1	13, 10AA636-1	603849, 42, 8AA465-2	21, AP1950-1	3, 4AA627-1	14, AP1964-1	702760, 32, AP1965-2
600597, 71, AX1851-3	602097, 14, 10AA636-1	603850, 43, 8AA465-2	7, AP1957-1	4, 4AA605-1	702024	702762, 8, AP1959-1
600598, 67, AX1851-3	602098, 17, 10AA636-1	603891, 11, AP1956-1	604974, 9, AP1957-1	5, 4AA606-1	11, AP1964-1	702778, 30, AX1582-2
600599, 69, AX1851-3	602099, 15, 10AA636-1	604252, 41, AX1582-2	604975	61680, 10, 4AB149-1	13, AP1964-1	702819
600600, 68, AX1851-3	602218, 6, AX1415-1	604253, 41, AX1415-1	10, AP1957-1	61683	702026, 15, AP1964-1	102, BP183-4
600670	602219, 45, AX1582-2	604256, 22, AX1582-1	38, AP1965-2	12, 6AA377-1	702029, 19, AP1964-1	82, BP76-3
22, AX1450-1	602275, 61, AX1582-2	604257, 27, AX1582-1	604976, 11, AP1957-1	2, 7AB14-1	702034, 31, AP1952-2	703172, 8, AP1954-1
40, AX1582-2	602293	28, AX1582-2	604977, 12, AP1957-1	3, AX1854-1	702037, 8, AP1965-1	703472, 104, BP183-4
600716, 3, AP1960-1	10, AX1580-1	6, AX1450-1	604986, 12, AP1958-1	5, 7AA64-1	702039, 15, AP1965-1	84, BP76-3
600726, 20, 10DA318-1	14, AX1868-1	604879, 4, AP1950-1	604988, 2, AP1959-1	7, 7AA62-1	702049, 34, AP1965-2	704390, 73, 10AE736-3
600753	602296, 15, AX1415-1	604880, 12, AP1950-1	604997, 2, AP1960-1	61799, 21, 8AA465-1	702050, 35, AP1965-2	704391, 76, 10AE736-3
25, 10DA318-1	602567	604881, 8, AP1950-1	604999, 2, AP1961-1	61974, 21, 11AA1035-1,	702052, 6, AP1950-1	704546, 6, AP1959-1
6, 10DA320-1	49, 11AA1035-2	604882, 13, AP1950-1	605000, 3, AP1961-1	11AA1036-1	702067, 4, AX1583-1	704578, 1, AP1958-1
600830, 39, 8AA463-2	73, 11AA1036-3	604883, 11, AP1950-1	605001, 7, AP1961-1	62179, 3, 4AB152-1	702080, 2, AP1955-1	704684, 26, AX1581-2
600831, 20, 8AA466-1	602568	604887, 17, AP1950-1	605003, 12, AP1961-1	62203	702126, 27, AP1952-1	704713, 9, AP1952-1
600832, 30, 8AA466-2	52, 11AA1035-2	604888, 18, AP1950-1	605013, 2AA163-0	27, 4AB149-2	702138	704926, 42, AP1965-2
600833, 4, 8AA467-1	74, 11AA1036-3	604889, 14, AP1950-1	4, AP1965-1	8, 4AA605-1,	3, AX1450-1	704934, 21, AP1952-1
600834, 9, 8AA467-1	602729	604894, 3, AP1951-1	605014, 3, AP1965-1	4AA606-1	4, AX1582-1	704936, 6, AP1958-1
601243, 8, AX1449-1,	100, BP183-4	604895, 3, AP1951-1	605019, 17, AP1965-1	6224	702147, 7, AX1583-1	704937, 2, AP1958-1
AX1581-1	80, BP76-3	604896, 3, AP1951-1	604896, 3, AP1965-1	17, 6BB163-1	702158, 27, AP1965-1	704938, 3, AP1958-1
601246	602730	604897, 3, AP1951-1	605029, 33, AP1965-2	45, 6BB162-1	702286, 3, AP1844-1	705009
31, AX1582-2	101, BP183-4	604904, 12, AP1951-1	605030	63544	702287, 2, AP1844-1	13, BP178-1
9, AX1450-1	81, BP76-3	604905, 13, AP1951-1	1, 11CD161-1	12, 8AA473-1	702289, 4, AP1844-1	17, BP182-1
601323, 36, 8AA466-2	602780, 36, AX1449-2	604906, 14, AP1951-1	46, AP1965-2	13, 8AA474-1	702291, 13, AP1955-1	705459, 5, AP1957-1
601324, 38, 8AA466-2	602787, 1, AX1450-1	604907, 15, AP1951-1	605036	14, 8AA475-1	702310, 26, AP1954-1	705645, 27, AX1581-2
601558, 3, AX1449-1	602788, 7, AX1450-1	604908, 16, AP1951-1	40, AP1965-2	63546	702311, 27, AP1954-1	705646, 28, AX1581-2
601561, 6, AX1867-1,	602789, 20, AX1450-1	604909, 17, AP1951-1	44, AP1965-2	10, 9AA323-1	702312, 32, AP1954-2	705892
AX1584-1	603210, 14, 8AA466-1	604910, 18, AP1951-1	60998, 14, 4AB152-1	23, 9AA322-1	702314, 27, AP1964-1	103, BP183-4
601589, 8, BC154-1	603303, 20, AX1449-1	604911, 19, AP1951-1	61308	3, 6AA375-1	702318	83, BP76-3
601590, 13, BC154-1	603304, 40, 8AA463-2	604912, 8, AP1951-1	13, 7AA62-1	9, 4AC223-1	18, AP1952-1	705991
601592, 30, BC154-2	603305, 34, 8AA464-2	604921, 33, AP1952-2	19, 4AB149-1	63547	6, 11CD161-1	14, AP1965-1
601593, 17, BC154-1	603306, 31, 8AA465-2	604922	61323	1, 10AE736-1	702330, 10, AP1964-1	4, 11CD161-1
601594, 14, BC154-1	603310, 15, AX1449-1	603311, 19, AX1449-1	13, AP1844-1	11, 4AB149-1	702331, 17, AP1964-1	706031, 8, AX1580-1
601597, 18, BC154-1				42, 4AA604-1	702332, 25, AP1964-1	706355, 63, AX1582-2

PARTS INDEX: *Part no., Item no., Page (Assembly Ref. no.)*

CATALOG 809816, R02-09

<p>706497, 2AA163-0 706587, 47, AP1965-2 706961, 62, AX1582-2 706962, 64, AX1582-2 706964, 15, AP1950-1 706965, 14, AP1952-1 706970, 2, AP1957-1 706971, 20, AP1954-1 706972, 21, AP1954-1 706974, 6, AP1965-1 706975, 7, AP1965-1 71940, 25, 4AA606-1 720991, 36, 11AA1035-2, 11AA1036-2 72339, 6, 10AF592-1 72437, 49, 8AA464-2 73191, 18, 10AE736-1 736851, 30, AP1965-2 73979, 3, 4AA603-1 740840, 11, AP1951-1 740862 10, AP1953-1 6, AP1953-1 740873, 15, AP1953-1 741054, 37, AP1965-2 744839, 1, AP1956-1 745076, 1, AP1955-1 745669, 11, AP1954-1 745798, 4, AP1951-1 745800, 1, AP1957-1 745801 19, AP1950-1 2, 11CD161-1 745999, 9, AP1962-1 746100, 4, AP1951-1 746101, 4, AP1951-1 746102, 4, AP1951-1 746433, 20, AP1964-1 746434, 1, AP1965-1 746435, 45, AP1965-2 747027, 2AA163-0 747371, 16, AP1953-1 747530, 10, AP1954-1 747605, 9, AP1951-1 747606, 1, AP1952-1 747607, 4, AP1952-1 747608, 5, AP1952-1 747609, 8, AP1952-1 747610 10, AP1952-1 15, AP1952-1 747611 11, AP1952-1 16, AP1952-1 747612 12, AP1952-1 17, AP1952-1 747613, 13, AP1952-1 747614, 1, AP1953-1 747615, 4, AP1953-1 747616 5, AP1953-1 9, AP1953-1</p>	<p>747617, 8, AP1953-1 747619, 9, AP1965-1 747620, 29, AP1965-2 747621, 14, AP1956-1 747622, 1, AP1959-1 747624, 5, AP1965-1 747625, 2, AP1965-1 747626, 48, AP1965-2 747627, 41, AP1965-2 747648, 1, AP1954-1 748404, 1, AP1950-1 748409, 6, AP1964-1 748411, 36, AP1965-2 748412, 39, AP1965-2 748455, 23, AP1964-1 75498, 17, 4AB152-1 75992, 8, 6AA367-1 76571, 27, 12AA463-1 77399, 12, 5AA101-1 775827, 19, AP1954-1 77808, 46, 12AA463-1 77957, 32, 6BB162-1 78086, 4, 4AA627-1 78088, 13, 4AA627-1 781742, 1, AP1963-1 78310, 9, 8AA476-1 78806, 75, 11AA1035-3 79126 24, 11AA1035-1, 11AA1036-1 35, 6BB161-2 79412, 1, 6BB160-1 79414, 25, 6BB160-1 79533 11, 8AA462-1, 8AA468-1 12, 6AA372-1 14, 8AA464-1 42, 8AA466-2 5, 11CD134-1 61, 11AA1035-3, 11AA1036-3 79570, 24, 9AA322-1 800465, 38, 11AA1036-2 800554, 17, 10AF592-1 801532, 3, 6BA214-1 801820, 1, 4AA606-1 801822, 7, 4AA606-1 801851 1, 10DA320-1 21, 10DA318-1 3, 10AE736-1 801864 3, 6BB161-1 8, 6BB163-1 801885, 5, 6BB161-1 801886, 17, 6BB161-1 801924, 3, 6AA377-1 801943, 24, 4AB149-1 801949, 2, 4AA605-1 801950, 3, 4AA605-1 801992 1, 4AB149-1</p>	<p>65, AX1851-3 78, 4AB151-1 802010, 24, 6BB161-1 802025, 1, 8AA475-1 802047 19, 6AA377-1 3, 6AA376-1 802048, 6, 7AB14-1 802049, 16, 7AB14-1 802054, 19, 6BB161-1 802118, 5, 3AA245-1 802120, 2, 4AB149-1 802126, 15, 3AA245-2 802127, 4, 3AA245-1 802128, 24, 3AA245-2 802225 12, 11CD161-1 32, 4AC223-2 802263, 12, 10AA633-1 802288, 17, 4AC223-1 802292, 16, 4AB149-1 802354 13, 10AA633-1 23, 10AA634-1 802358, 53, 10AE736-3 802367, 26, 10AE736-1 802398, 2, 8AA480-1 802451, 13, 10AA634-1 802504, 11, 4AB152-1 802615, 28, 9AA322-2 802616, 29, 9AA322-2 802658, 2, 8AA462-1 802661, 4, 3AA246-1 802704, 46, 6BB160-2 802755 10, 8AA462-1 13, 8AA504-1, 8AA663-1, 8AA664-1 802769, 1, 9AA323-1 802771 14, 8AA663-1, 8AA664-1 7, 8AA504-1 802779, 22, 6BB161-1 802780, 5, 6BB160-1 802781, 20, 6BB160-1 802820, 3, 8AA468-1 802821, 4, 8AA468-1 802822, 5, 8AA468-1 802833, 11, 12AA463-1 802861, 15, 8AA663-1, 8AA664-1 802874, 25, 9AA322-1 802876, 4, 6BB161-1 802884, 2, 9AA323-1 802885, 36, 4AA604-1 802887, 39, 4AA604-1 802889, 37, 4AA604-1 802892, 38, 4AA604-1 802898, 36, 4AB149-2 802932, 10, 6AA372-1 802934, 26, 4AA606-1</p>	<p>802936, 15, 11AA1035-1, 11AA1036-1 802937, 37, 11AA1035-2, 11AA1036-2 802942, 8, 9AA323-1 802943, 5, 9AA323-1 802944, 3, 9AA323-1 802945, 6, 9AA323-1 802946, 7, 9AA323-1 802964, 19, 3AA245-2 802976, 44, 6BB160-2 802977, 39, 11AA1035-2, 11AA1036-2 802979, 4, 6BA214-1 802983, 7, 10AF592-1 802986, 74, 11AA1035-3 803004, 8, 3AA246-1 803007, 8, 3AA245-1 803011, 11, 3AA245-1 803020, 13, 10AF592-1 803025 11, 10AE736-1 85, 10BA302-1 803026 30, 10AE736-2 53, 4AB151-1 803027, 39, 10AE736-2 803028, 37, 10AE736-2 803030, 36, 10AE736-2 803031, 21, 10AE736-1 803032, 22, 10AE736-1 803039 20, 10AA634-1 21, 10AA633-1 803042, 19, 6AA372-1 80305, 12, 6BB160-1 803071, 2AA163-0 803077, 15, 8AA474-1 803079, 26, 9AA322-1 80308, 5, 4AA627-1 803082, 6, 8AA665-1 803083, 7, 8AA665-1 803138, 8AA485-1 803140, 3, 8AA485-1 803142, 2, 8AA485-1 803143, 2, 8AA665-1 803144, 1, 8AA485-1 803145, 1, 8AA665-1 803148, 28, 12AA463-1 803149, 29, 12AA463-1 803150, 30, 12AA463-1 803151, 31, 12AA463-1 803152, 32, 12AA463-1 803153, 33, 12AA463-1 803156, 36, 12AA463-1 803157, 37, 12AA463-1 803158, 38, 12AA463-1 803168 1, 11CC225-1 5, 11CC226-1 803169 14, 11CC225-1 23, 11CC226-1</p>	<p>803174, 12, 4AB152-1 803175, 9, 4AB152-1 803177 3, 10AF592-1 70, 10BA302-1 803180, 13, 4AB152-1 803182 22, 4AB152-1 4, 10AF592-1 803184 24, 4AB152-1 69, 10BA302-1 803185, 16, 4AB152-1 803187, 71, 10BA302-1 803188 6, 6AA372-1 68, 10BA302-1 803194, 72, 10BA302-1 803196, 2, 4AB152-1, 10AF592-1 803198, 82, 10BA302-1 803199, 80, 10BA302-1 803202 2, 11CC225-1 6, 11CC226-1 803205, 2, 4AB149-1 803208, 2, 11CC226-1 803209, 3, 11CC226-1 803229, 2, 6AA377-1 803269, 12, 10AA634-1 803270, 50, 4AB151-1 803271, 33, 4AB149-2 803275, 42, 4AB149-2 803282, 4, 7AB14-1 803285, 31, 7AA62-2 803288, 1, 6AA372-1 803289, 2, 6AA372-1 803290, 4, 6AA372-1 803291, 9, 6AA372-1 803293, 54, 10AE736-3 803313, 42, 12AA463-1 803326, 55, 10AE736-3 803328, 56, 10AE736-3 803337, 55, 10AE736-3 803338, 56, 10AE736-3 803388, 1, 4AA627-1 803392, 4AA627-1 803393 16, 8AA664-1 17, 8AA663-1 803399, 12, 11CC228-1 803409, 11, 11CD129-1 803412, 1, 11CC228-1 803417, 72, 8AA464-3 803458, 4, 8AA483-1 803461, 5, 8AA483-1 803470-2 21, 10AE762-1 52, 10AE736-2 803470-2 22, 10AE762-1 52, 10AE736-2</p>	<p>803470KIT, 20, 10AE762-1 803499, 1, 8AA482-1 803501, 4, 4AA602-1 803506, 2, 8AA482-1 803543, 13, 3AA246-1 803560, 8, 6AA376-1 803566, 38, 4AB151-1 803570, 39, 4AB151-1 803576, 25, 7AA62-2 803585, 40, 4AB151-1 803607, 6, 4AA602-1 803611, 37, 4AB151-1 803614, 5, 6AA377-1 803617, 4, 6AA377-1 803621, 9, 8AA485-1 803622, 7, 8AA485-1 803623, 8, 8AA485-1 803624, 12, 8AA485-1 803625, 10, 8AA485-1 803626, 11, 8AA485-1 803653, 21, 4AA601-1 803654, 2AA163-0 803655, 2AA163-0 803656, 23, 4AA601-1 803663 19, 8AA664-1 20, 8AA663-1 803666, 47, 12AA463-1 803667, 48, 12AA463-1 803677, 27, 9AA322-1 803684, 1, 4AB152-1 803723, 9, 8AA472-1 803726, 9, 10AA635-1 803732, 52, 6BB160-2 803733, 24, 10AA634-1 803734, 45, 10AE736-2 803735, 26, 10AA634-1 803762, 31, 6BB160-2 803817, 2, 10AE737-1 803818, 1, 10AE737-1 803820, 3, 10AE737-1 803821, 4, 10AE737-1 803822, 5, 10AE737-1 803823, 6, 10AE737-1 803824, 7, 10AE737-1 803825, 8, 10AE737-1 803826, 9, 10AE737-1 803827, 10AE737-1 803840, 11, 10AE737-1 803841, 10, 10AE737-1 803842, 16, 10AE737-1 803843, 15, 10AE737-1 803844, 14, 10AE737-1 803845, 13, 10AE737-1 803875, 14, 4AA627-1 803885, 3, 4AB149-1 803886, 31, 4AB151-1 803917, 33, 4AA601-2 803918, 32, 4AA601-2 803920, 9, 7AA62-1</p>	<p>803922, 11, 7AA62-1 803966, 28, 10AA634-1 803986, 2, 8AA479-1 804024, 11, 11CC226-1 804025, 12, 11CC226-1 804044, 20, 6AA372-1 804064 1, AX1854-1 15, 7AB14-1 804128, 74, 4AB151-1 804130, 75, 4AB151-1 804222, 9, 6BB163-1 804272 20, 8AA664-1 21, 8AA663-1 804274, 8AA664-1 804285, 21, 6AA372-1 804303, 12, 8AA462-1 804326, 28, 9AA322-2 804327, 29, 9AA322-2 804338, 11, 4AA601-1 804339, 12, 4AA601-1 804345, 33, 9AA322-2 804346, 32, 9AA322-2 804358, 11, 8AA472-1 804432, 1, 10AA635-1, 11CD129-1 804434, 4, 10AA635-1 804435, 2, 10AA635-1 804436, 18, 3AA245-2 804439L, 17, 3AA245-2 804439R, 16, 3AA245-2 804440, 14, 3AA245-2 804442L, 13, 3AA245-1 804442R, 12, 3AA245-1 804443, 23, 3AA245-2 804445L, 22, 3AA245-2 804445R, 21, 3AA245-2 804446, 7, 3AA246-1 804448L, 6, 3AA246-1 804448R, 5, 3AA246-1 804450L, 10, 3AA246-1 804450R, 9, 3AA246-1 804452, 3, 3AA246-1 804454L, 2, 3AA246-1 804454R, 1, 3AA246-1 804457L, 12, 3AA246-1 804457R, 11, 3AA246-1 804458, 3, 3AA245-1 804460L, 2, 3AA245-1 804460R, 1, 3AA245-1 804462L, 7, 3AA245-1 804462R, 6, 3AA245-1 804464L, 10, 3AA245-1 804464R, 9, 3AA245-1 804500, 13, 4AA601-1 804553, 34, 7AA62-2 804554, 7AA62-1 3, 7AA64-1 804597, 10, 11CD129-1 804598, 12, 11CD129-1 804599, 26, 11CD129-1</p>
---	--	--	--	---	--	--

PARTS INDEX: Part no., Item no., Page (Assembly Ref. no.)

CATALOG 809816, R02-09

804600, 6, 11CD129-1 804604, 34, 4AA606-2 804605, 35, 4AA606-2 804611, 43, 4AB149-2 804612, 41, 4AB149-2 804636, 5, 11BA103-1 804641, 46, 11AA1035-2, 11AA1036-2 804661, 44, 11AA1035-2, 11AA1036-2 804684, 5, 4AA602-1 804686, 2, 11BA103-1 804707, 16, 11CD129-1 804722, 11, 4AA603-1 804768, 2, 12AA463-1 804776 15, 11CD129-1 5, 10AA635-1 50, 10AE736-2 804781 7, 8AA462-1 9, 8AA504-1 804782 6, 8AA462-1 8, 8AA504-1 804783, 1, 8AA462-1 804806, 20, 6BB163-1 804808, 18, 11CD129-1 804809, 19, 11CD129-1 804819, 27, 11CD129-1 804828, 6, 6AA376-1 804831, 47, 11AA1035-2, 11AA1036-2 804832, 45, 11AA1035-2, 11AA1036-2 804881, 25, 11CD129-1 804930, 43, 11AA1035-2, 11AA1036-2 805118, 10, 4AB152-1 805119, 23, 4AB152-1 805120, 15, 4AB152-1 805121, 29, 4AB152-1 805145, 2, 11CC228-1 805492, 2, 8AA479-1 805537, 46, 4AA604-1 805642, 78, 10AE736-3 805677, 30, 4AB149-2 805683, 4, 11BA121-1 805685, 22, 8AA663-1 805791, 16, 11CC228-1 805887 10, 11BA121-1 28, 11AA1035-1, 11AA1036-1 805888 1, 11BA119-1 15, 11BA120-1 17, 11CC225-1 26, 11CC226-1 29, 11AA1035-1, 11AA1036-1 805889 1, 11CD134-1 30, 11AA1035-2, 11AA1036-2 805904 10, 11CC226-1 4, 11CC225-1 805905, 14, 11CC226-1 805907, 53, 11AA1035-2, 11AA1036-2 805911, 9, 6BA214-1 805912, 10, 6BA214-1 805923, 71, 11AA1035-3, 11AA1036-3 805924, 72, 11AA1035-3, 11AA1036-3 805936 16, 11CC226-1 7, 11CC225-1 805937 15, 11CC226-1 6, 11CC225-1 805938 12, 11CC225-1 21, 11CC226-1 805939 13, 11CC225-1 22, 11CC226-1 805946, 34, 11AA1035-2 805947, 27, 11AA1035-1 805950, 71, 8AA464-3 805957, 34, 11AA1036-2 805973, 16, 11BA120-1 806132, 26, 11AA1035-1, 11AA1036-1 806341 11, 11BA121-1, 11BA122-1 15, 11CC225-1 17, 11BA120-1 24, 11CC226-1 6, 11CC228-1 77, 11AA1035-3, 11AA1036-3 8, 11BA119-1, 11CD134-1 806371, 5, 6BA214-1 806372 1, 10AF592-1 6, 6BA214-1 79, 10BA302-1 806373, 11, 6BA214-1 806374, 7, 6BA214-1 806375, 8, 6BA214-1 806376, 13, 6BA214-1 806377, 12, 6BA214-1 806485, 50, 12AA463-1 806748 37, 6BB162-1 4, 6BB163-1 806757, 5, 4AA603-1 806789, 6, 4AA603-1 806827, 2AA163-0 806869, 10, 6BB163-1 806876 11, 6AA372-1 14, 11AA1036-1 806883, 1, 10AE762-1 806884, 4, 10AE762-1 806885, 2, 10AE762-1 806887, 7, 10AE762-1 806888, 8, 10AE762-1 806889, 9, 10AE762-1 806890, 10, 10AE762-1 806891, 11, 10AE762-1 806892, 12, 10AE762-1 806893, 13, 10AE762-1 806894, 14, 10AE762-1 806895, 15, 10AE762-1 806896, 16, 10AE762-1 806897, 17, 10AE762-1 806898, 18, 10AE762-1 806937L, 31, 3AA245-2 806937R, 30, 3AA245-2 806938, 32, 3AA245-2 806939, 33, 3AA245-2 806955, 49, 4AB151-1 806962, 22, 6AA372-1 806993, 8, 8AA472-1 807111, 80, 8AA463-3 807121, 7, 11AA1035-1, 11AA1036-1 807150, 5, 10AE762-1 807156, 6, 11BA103-1 807167, 8, 8AA481-1 807168 10, 8AA480-1 18, 8AA479-1 807170 3, 11CC225-1 9, 11CC226-1 807238, 1, AP1844-1 807290, 9, 6AA377-1 807291, 10, 6AA377-1 807296, 4, 4AA603-1 807371 1, AX1867-1 4, 6AA376-1 807376, 5, 8AA504-1 807414, 1, 6AA367-1 807431 22, 10AA634-1 23, 10AA633-1 807434, 1, 4AC223-1 807440, 3, 4AC223-1 807441, 28, 4AC223-1 807449 23, 8AA664-1 24, 8AA663-1 807459, 14, 4AA601-1 807464, 35, 4AA604-1 807485, 18, 6AA377-1 807487, 6, 8AA482-1 807489, 7, 8AA482-1 807492, 1, 6AA375-1 807511, 7, 11BA121-1 807514 1, 11BA120-1 2, 11BA119-1 3, 11AA1035-1, 11AA1036-1 5, 11BA121-1 807543, 1, 8AA479-1, 8AA480-1 807555, 11, 8AA467-1 807556, 10, 8AA467-1 807557, 13, 8AA467-1 807558, 12, 8AA467-1 807559, 17, 8AA467-1 807565, 65, 11AA1035-3, 11AA1036-3 807568, 51, 11AA1035-2, 11AA1036-2 807578, 34, 12AA463-1 807579, 35, 12AA463-1 807659, 35, 11AA1035-2, 11AA1036-2 807662, 11CD135-1 18, 11AA1036-1 807664, 2, 11AA1035-1, 11AA1036-1 807665, 11, 11AA1035-1, 11AA1036-1 807666, 40, 11AA1035-2, 11AA1036-2 807667 3, 11BA119-1 5, 11AA1035-1, 11AA1036-1 807670, 18, 11AA1035-1 807675, 80, 4AB151-1 807677, 86, 10BA302-1 807682, 92, 10BA302-1 807683, 40, 10AE736-2 807688, 34, 4AB149-2 807689, 35, 4AB149-2 807699, 81, 10BA302-1 807700, 76, 10BA302-1 807701, 15, 10AF592-1 807703, 75, 10BA302-1 807705, 83, 10BA302-1 807706, 84, 10BA302-1 807707, 18, 10AF592-1 807710, 74, 10BA302-1 807712, 16, 10AF592-1 807716, 23, 10AE736-1 807717, 24, 10AE736-1 807718, 35, 10AE736-2 807719, 12, 10AE736-1 807720, 13, 10AE736-1 807722, 73, 10BA302-1 807723 1, 11CC189-1 10, 8AA504-1 807724, 6, 8AA504-1 807730, 78, 10BA302-1 807746, 19, 4AA606-1 807750, 4, 11BA119-1 807773, 88, 10BA302-1 807776, 12, AX1868-1 807801 1, BC154-1 47, 4AB151-1 807813, 16, 5AA101-1 807815 23, 10AE762-1 52, 10AE736-2 807815KIT, 20, 10AE762-1 807822, 11CC226-1 807824 13, 11CC226-1 5, 11CC225-1 807826 10, 11BA122-1 18, 11CC225-1 20, 11BA120-1 27, 11CC226-1 5, 11BA119-1 7, 11CC228-1 9, 11CD134-1 807831 1, 7AA64-1 7, 7AB14-1 807836 17, 7AB14-1 2, 7AA64-1 807839, 8AA665-1 807840, 11CC225-1 807841, 8, 8AA665-1 807842, 9, 8AA665-1 807850, 12, AP1844-1 807853, 5, 11BA122-1 807854, 3, 11BA122-1 807865, 34, 4AA604-1 807867, 11, AP1844-1 807871, 18, 11BA120-1 807872, 19, 11BA120-1 807875, 10, 8AA665-1 807876, 11, 8AA665-1 807878, 4, 11CC228-1 807879, 8, 11CC228-1 807880, 9, 11CC228-1 807881, 1, 11CC228-1 807882, 11, 11CC228-1 807883, 23, 12AA463-1 807886, 12AA463-1 807887, 12AA463-1 807888, 12AA463-1 807889, 12AA463-1 807890, 12AA463-1 807891, 12AA463-1 807892, 12AA463-1 807893, 12AA463-1 807894, 12AA463-1 807895, 12AA463-1 807896, 12AA463-1 807897, 12AA463-1 807898, 12AA463-1 807899, 12AA463-1 807900, 12AA463-1 807901, 12AA463-1 807902, 12AA463-1 807903, 12AA463-1 807904, 12AA463-1 807905, 12AA463-1 807906, 12AA463-1 807907, 12AA463-1 807908, 12AA463-1 807909, 12AA463-1 807910, 12AA463-1 807911, 12AA463-1 807912, 12AA463-1 807913, 12AA463-1 807914, 12AA463-1 807915, 12AA463-1 807918, 2, 11CD134-1 807923, 40, 12AA463-1 807924, 2, 6AA367-1 807926 1, AX1867-1 8, 6AA377-1 807929, 8, 11BA121-1 807957, 16, 8AA472-1 809795, 60, 4AB149-2 809796, 59, 4AB149-2 809840, 3, 10AE762-1 809841, 6, 10AE762-1 81044 23, 6BB160-1 29, 6BB161-2 812038L, 27, 3AA245-2 812038R, 26, 3AA245-2 812039, 25, 3AA245-2 812041 21, 11BA120-1 9, 11BA121-1 812079, 1, 4AA627-1 812083, 4AA627-1 812087 69, 11AA1035-3 75, 11AA1036-3 812096, 6, 11BA119-1 812097, 7, 11BA119-1 812106, 27, 4AA606-1 82520, 14, 8AA472-1 86506 25, 4AB152-1 48, 11AA1035-2, 11AA1036-2 86832, 35, 7AA62-2 89179, 28, 7AA62-2 B114A3 24, 10AA633-1 9, 11CD129-1 B169, 2AA163-0 2, 4AC223-1 B2236-12, 15, 4AA601-1 B2236-15, 2AA163-0 B2236-3 16, 6AA376-1 2, 8AA468-1 26, 6AA377-1 B2236-8, 12, 4AA603-1 B254-2, 4, 9AA323-1 B3500, 20, 6BB161-1 B3698-15, 6, 4AC223-1 B3698-17, 25, 4AB149-1 B3698-21, 58, 10AE736-3 B3698-25, 7, 10AA635-1 B3698-8 13, 6AA376-1 28, 6AA377-1 3, 11BA120-1 6, 11BA121-1 B5407, 9, 5AA101-1 B5425, 46, 10AE736-2 B5795, 10, 5AA101-1 B6108, 20, 12AA463-1 B6109, 1, 12AA463-1 B6119, 11, 5AA101-1 B6143, 25, 12AA463-1 B7860, 70, 10AE736-3 K134, 16, 7AA62-1 K20346SS, 4, 8AA480-1 K20348, 48, 10AE736-2 K20386SS 14, 6BB161-1 16, 6BB160-1 K20388 14, 11CD129-1 6, 10AA635-1 7, 5AA101-1 K20391 10, 8AA479-1 6, 8AA481-1 9, 8AA480-1 K20424, 16, 4AA601-1 K20428 10, 10AA635-1 57, 10AE736-3 6, 6AA377-1 K224-6, 8, 11CD129-1 K247-4-2, 17, 11CC228-1 K300858, 11, 6BB163-1 K302211, 21, 4AB149-1 K302264, 8, 7AA62-1 K33770, 5, 8AA479-1, 8AA481-1 K33795, 17, 4AA601-1 K33799, 27, 7AA62-2 K33922 13, 6BB161-1 18, 6BB160-1 K34691 1, 6AA376-1 17, 6AA377-1 K34791, 4, 8AA479-1, 8AA481-1 K34805 18, 4AA601-1 87, 10BA302-1 K34806, 6, 8AA480-1 K34806SS 17, 6BB160-1 6, 6BB161-1 K34807

PARTS INDEX: *Part no., Item no., Page (Assembly Ref. no.)*

CATALOG 809816, R02-09

13, 11CD129-1	27, 4AB152-1	K58758, 15, 6AA377-1	K87914, 30, 7AA62-2	41, 10AE736-2	R32	11, 7AA64-1
3, 10AA635-1	5, 8AA480-1	K64-6, 90, 10BA302-1	K89778, 7, 6BB161-1	R106, 2, 5AA101-1	10, 7AB14-1	12, 7AA64-1
47, 10AE736-2	59, 10AE736-3	K71B1393, 65,	K97524, 16, 6BB161-1	R18147-3	9, 7AA64-1	31, 9AA322-2
6, 5AA101-1	K44728	10AE736-3	K97615, 61, 4AB149-2	14, 10AF592-1	R40, 43, 12AA463-1	44, 4AA604-1
K34808	7, 6AA377-1	K72016	KN605803, 13, 4AA606-1	42, 10AE736-2	R4584, 3, 5AA101-1	45, 4AA604-1
11, 8AA479-1	8, 10AA635-1	25, 8AA664-1	KN605815, 11, 4AA605-1	R18147-5	R7638, 4, 5AA101-1	Z4056
7, 8AA481-1	K44748, 5, 6AA376-1	26, 8AA663-1	KN630091, 17, 4AB149-1	30, 4AA606-2	T51534	3, 8AA665-1
8, 8AA480-1	K44877, 3, 8AA479-1,	K76176	KN630174, 12, 4AA606-1	44, 4AB149-2	1, 6AA377-1	4, 8AA665-1,
K34992, 7, 6AA376-1	8AA481-1	26, 8AA664-1	KN630361, 18, 4AB149-1	R19452, 56, 4AB151-1	3, 7AA62-1	8AA485-1
K44719	K45840, 10, 8AA472-1	27, 8AA663-1	M0000096-16, 20,	R19829-1, 52, 4AB151-1	Z2880, 49, 12AA463-1	5, 8AA485-1
12, 6BB163-1	K45894, 15, 8AA472-1	K8-326	11CD129-1	R19831-2, 91,	Z4053	Z4117, 10, 7AA64-1
19, 4AA601-1	K55691	14, 10AA634-1	M0000207, 15,	10BA302-1	30, 9AA322-2	Z4525
24, 8AA664-1	26, 4AB152-1	15, 10AA633-1	12AA463-1	R2016, 18, 12AA463-1	5, 8AA665-1	28, 4AB152-1
25, 8AA663-1	60, 10AE736-3	K87901, 1, 5AA101-1	M0001183	R25454, 5, 5AA101-1	6, 8AA485-1	64, 10AE736-3
89, 10BA302-1	K55748, 11, 10AA635-1	K87907, 38, 7AA62-2	3, 6AA372-1	R25456, 8, 5AA101-1	Z4054	77, 10BA302-1
K44722	K55961, 7, 8AA480-1					